



HERMON LABORATORIES

<b>Test specification:</b> Section 96.41(b), Maximum EIRP and maximum power spectral density			
<b>Test procedure:</b> Section 96.41(e)(3)			
<b>Test mode:</b> Compliance		<b>Verdict:</b> PASS	
<b>Date(s):</b> 14-Dec-21			
<b>Temperature:</b> 25 °C	<b>Relative Humidity:</b> 54 %	<b>Air Pressure:</b> 1009 hPa	<b>Power:</b> 48 VDC
<b>Remarks:</b>			

Plot 7.1.19 Peak spectral power density at mid frequency

CHANNEL SPACING:  
ANTENNA CHAIN:  
Modulation: QPSK

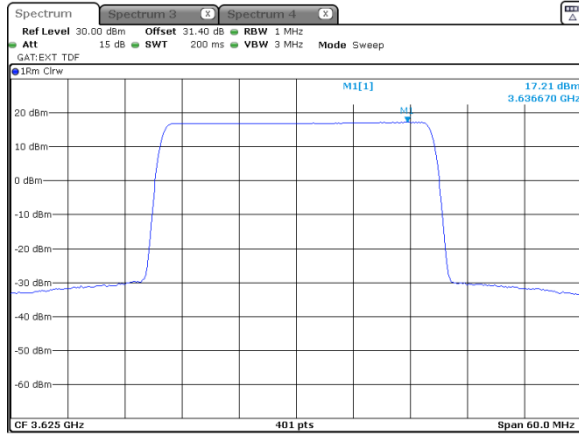

30 MHz  
3  
Modulation: 16QAM

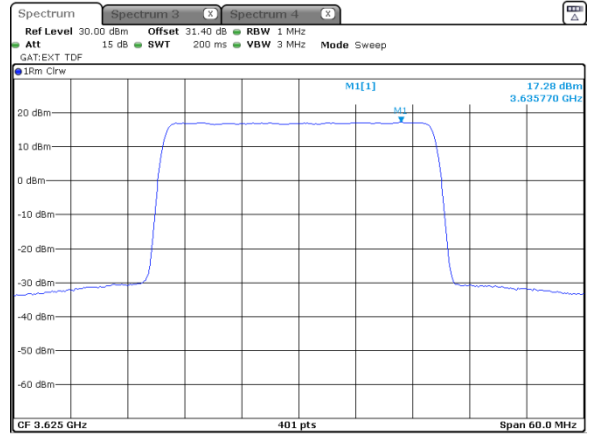

Modulation: 64QAM

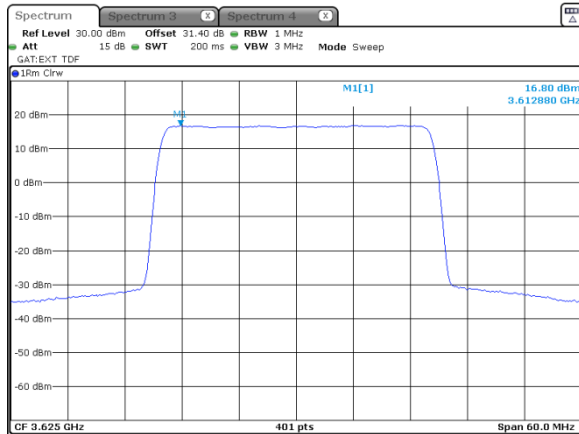

Modulation: 256QAM

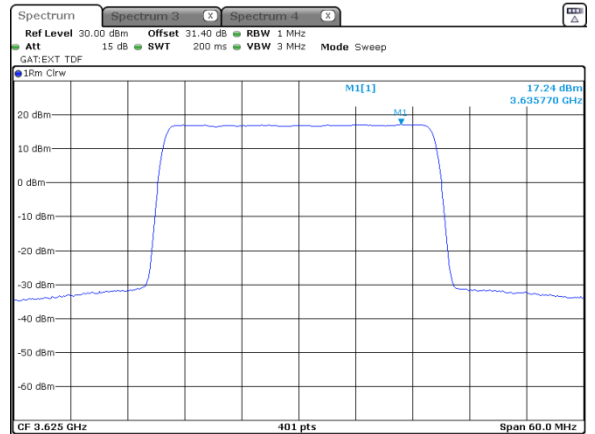



HERMON LABORATORIES

<b>Test specification:</b> Section 96.41(b), Maximum EIRP and maximum power spectral density			
<b>Test procedure:</b> Section 96.41(e)(3)			
<b>Test mode:</b> Compliance		<b>Verdict:</b> PASS	
<b>Date(s):</b> 14-Dec-21			
<b>Temperature:</b> 25 °C	<b>Relative Humidity:</b> 54 %	<b>Air Pressure:</b> 1009 hPa	<b>Power:</b> 48 VDC
<b>Remarks:</b>			

**Plot 7.1.20 Peak spectral power density at mid frequency**

CHANNEL SPACING:  
ANTENNA CHAIN:  
Modulation: QPSK

30 MHz  
4  
Modulation: 16QAM

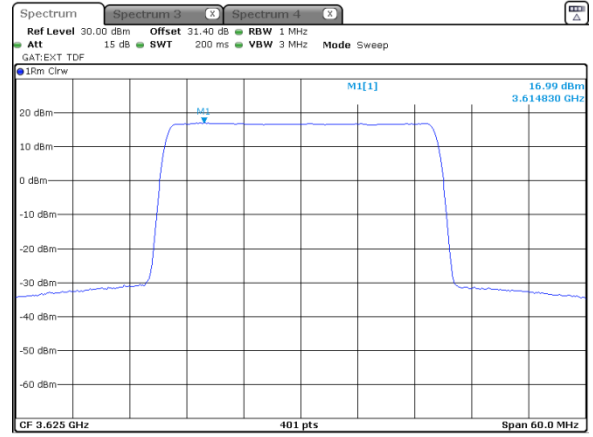
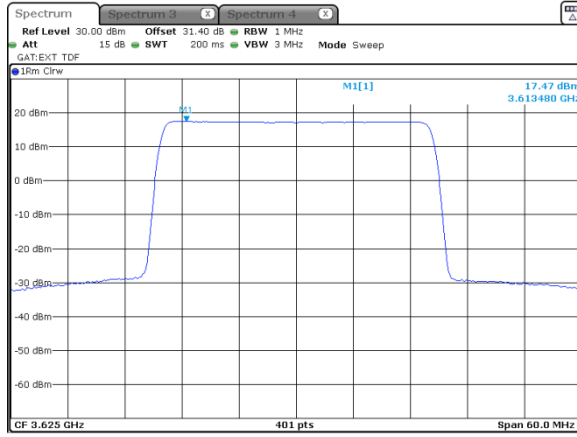

Modulation: 64QAM

Modulation: 256QAM

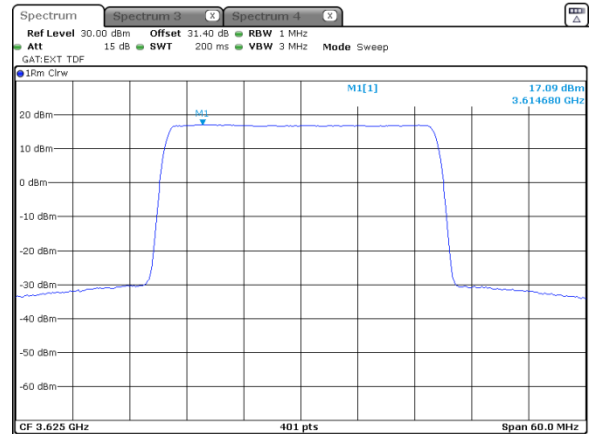
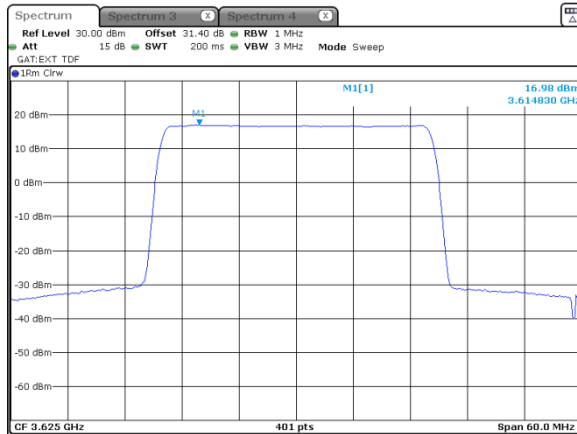



HERMON LABORATORIES

<b>Test specification:</b> Section 96.41(b), Maximum EIRP and maximum power spectral density			
<b>Test procedure:</b> Section 96.41(e)(3)			
<b>Test mode:</b> Compliance		<b>Verdict:</b> PASS	
<b>Date(s):</b> 14-Dec-21			
<b>Temperature:</b> 25 °C	<b>Relative Humidity:</b> 54 %	<b>Air Pressure:</b> 1009 hPa	<b>Power:</b> 48 VDC
<b>Remarks:</b>			

Plot 7.1.21 Peak spectral power density at high frequency

CHANNEL SPACING:  
ANTENNA CHAIN:  
Modulation: QPSK

30 MHz  
1  
Modulation: 16QAM

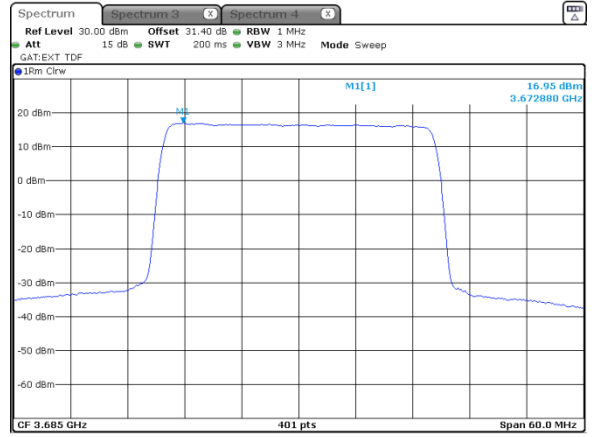
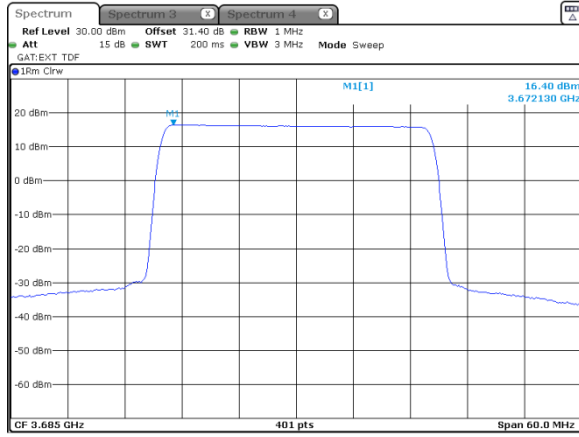

Modulation: 64QAM

Modulation: 256QAM

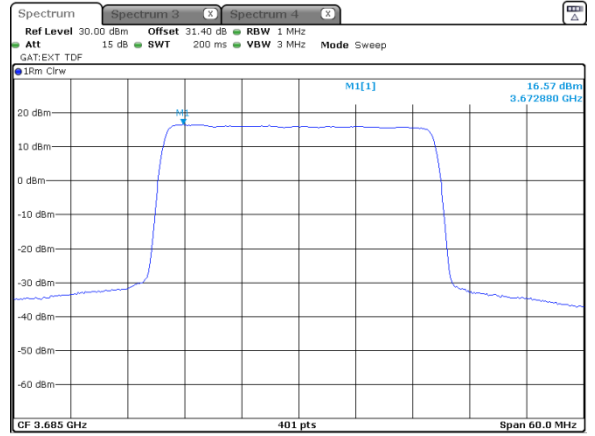
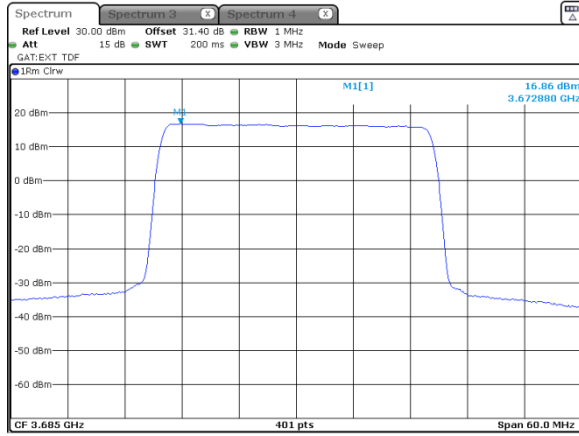



HERMON LABORATORIES

<b>Test specification:</b> Section 96.41(b), Maximum EIRP and maximum power spectral density			
<b>Test procedure:</b> Section 96.41(e)(3)			
<b>Test mode:</b> Compliance		<b>Verdict:</b> PASS	
<b>Date(s):</b> 14-Dec-21			
<b>Temperature:</b> 25 °C	<b>Relative Humidity:</b> 54 %	<b>Air Pressure:</b> 1009 hPa	<b>Power:</b> 48 VDC
<b>Remarks:</b>			

Plot 7.1.22 Peak spectral power density at high frequency

CHANNEL SPACING:  
ANTENNA CHAIN:  
Modulation: QPSK

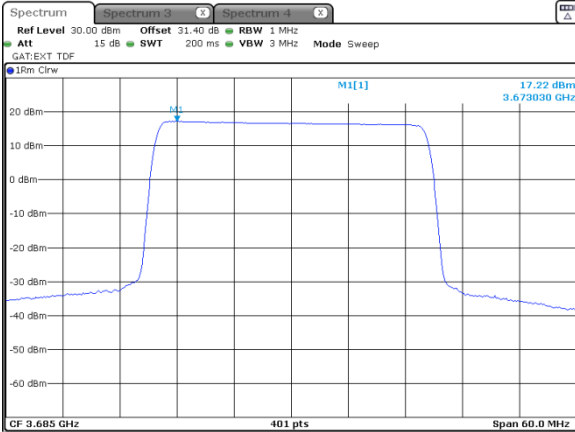

30 MHz  
2  
Modulation: 16QAM

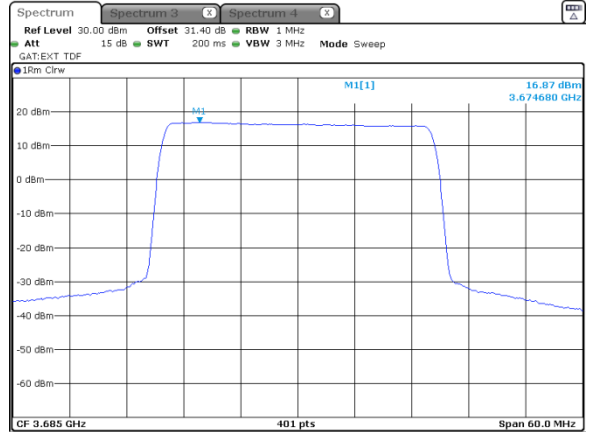

Modulation: 64QAM

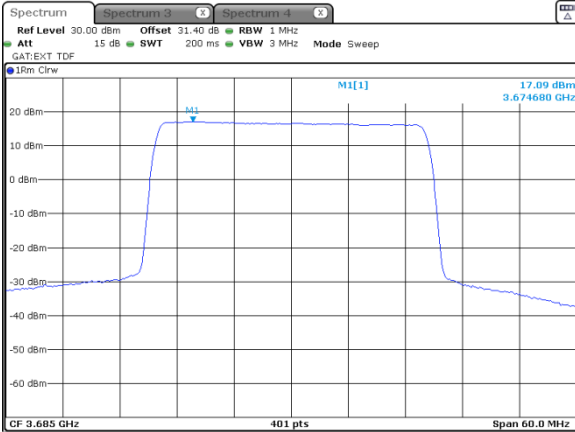

Modulation: 256QAM

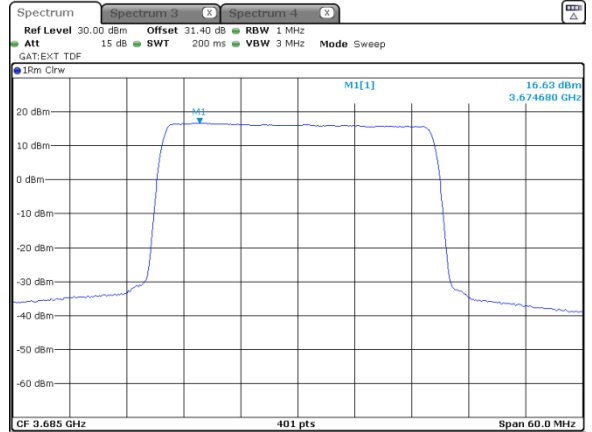



HERMON LABORATORIES

<b>Test specification:</b> Section 96.41(b), Maximum EIRP and maximum power spectral density			
<b>Test procedure:</b> Section 96.41(e)(3)			
<b>Test mode:</b> Compliance		<b>Verdict:</b> PASS	
<b>Date(s):</b> 14-Dec-21			
<b>Temperature:</b> 25 °C	<b>Relative Humidity:</b> 54 %	<b>Air Pressure:</b> 1009 hPa	<b>Power:</b> 48 VDC
<b>Remarks:</b>			

Plot 7.1.23 Peak spectral power density at high frequency

CHANNEL SPACING:  
ANTENNA CHAIN:  
Modulation: QPSK

30 MHz  
3  
Modulation: 16QAM

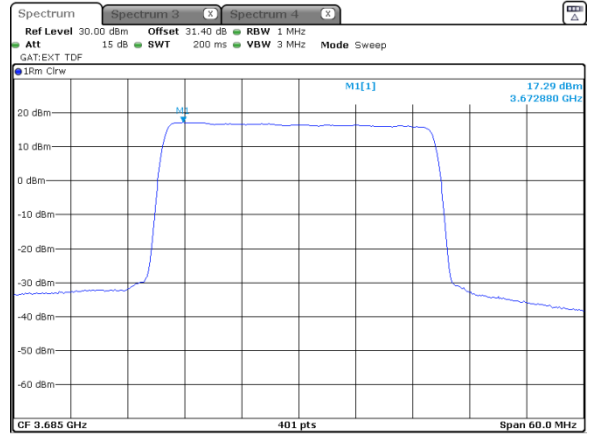
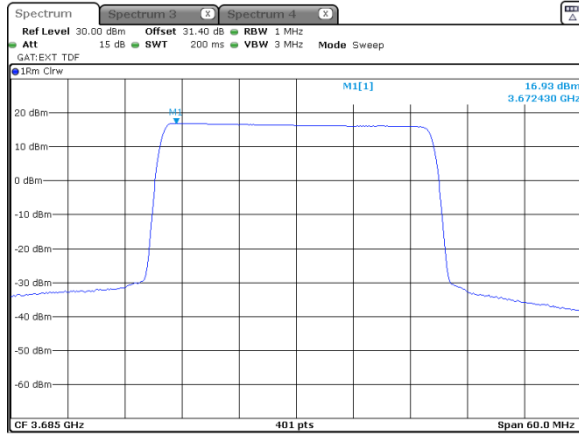

Modulation: 64QAM

Modulation: 256QAM

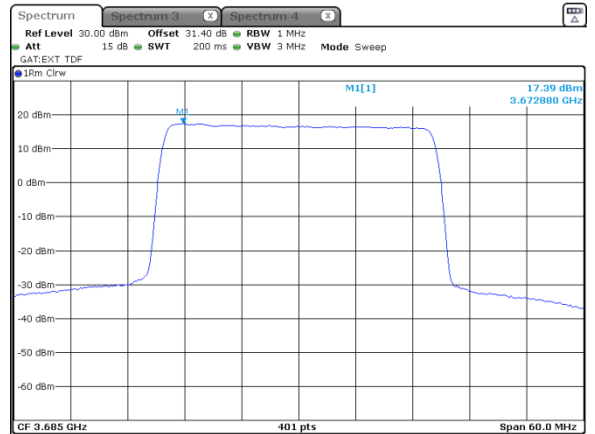
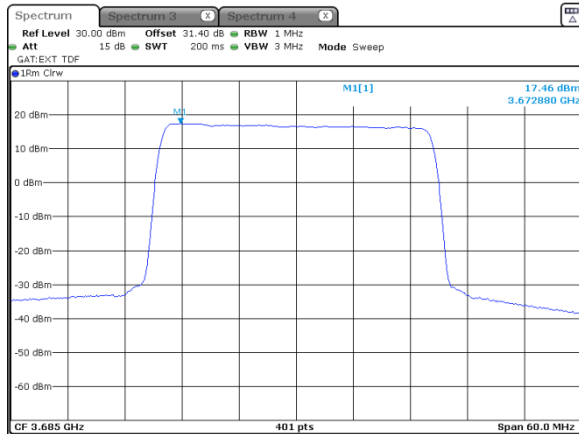



HERMON LABORATORIES

<b>Test specification:</b> Section 96.41(b), Maximum EIRP and maximum power spectral density			
<b>Test procedure:</b> Section 96.41(e)(3)			
<b>Test mode:</b> Compliance		<b>Verdict:</b> PASS	
<b>Date(s):</b> 14-Dec-21			
<b>Temperature:</b> 25 °C	<b>Relative Humidity:</b> 54 %	<b>Air Pressure:</b> 1009 hPa	<b>Power:</b> 48 VDC
<b>Remarks:</b>			

Plot 7.1.24 Peak spectral power density at high frequency

CHANNEL SPACING:  
ANTENNA CHAIN:  
Modulation: QPSK

30 MHz  
4  
Modulation: 16QAM

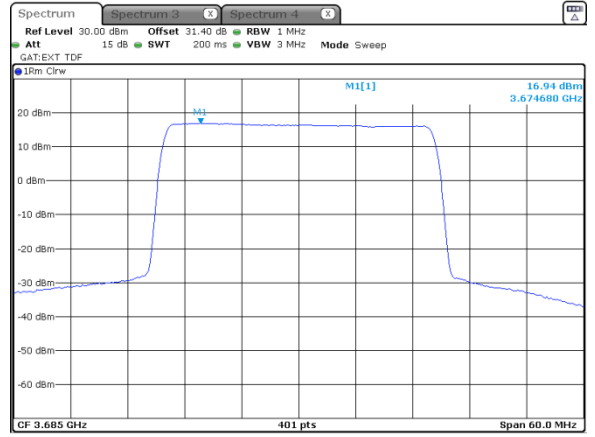
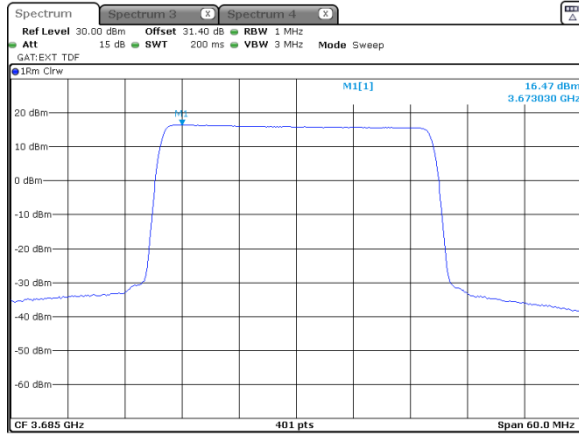

Modulation: 64QAM

Modulation: 256QAM

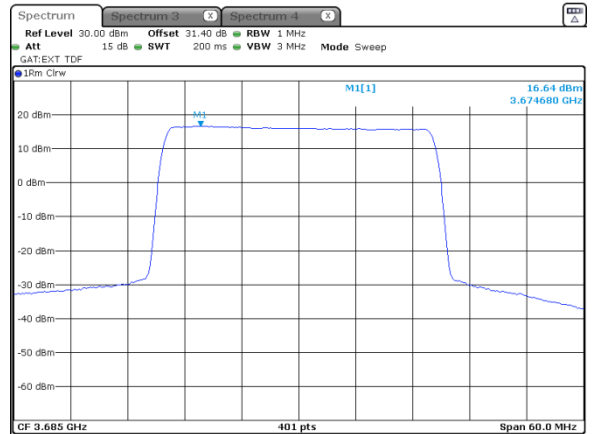
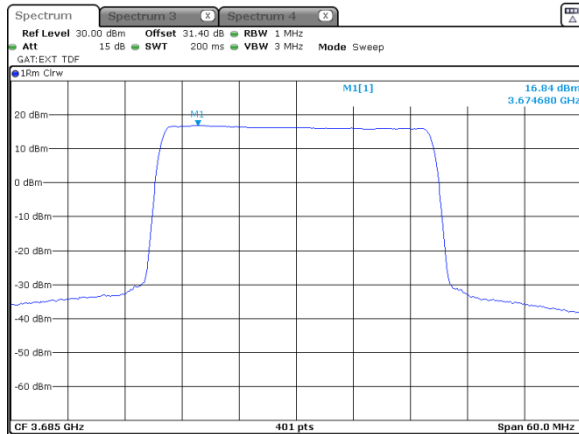



<b>Test specification: Section 96.41(g), Peak-to- average power ratio</b>			
<b>Test procedure:</b> Section 96.41(g)			
<b>Test mode:</b> Compliance		<b>Verdict: PASS</b>	
<b>Date(s):</b> 14-Dec-21			
<b>Temperature:</b> 25 °C	<b>Relative Humidity:</b> 54 %	<b>Air Pressure:</b> 1011 hPa	<b>Power:</b> 48 VDC
<b>Remarks:</b>			

## 7.2 Peak-to-average power ratio (PAPR) test

### 7.2.1 General

This test was performed to measure the peak to average power ratio at RF antenna connector. Specification test limits are given in Table 7.2.1.

Table 7.2.1 Peak-to-average power ratio limits

Assigned frequency range, MHz	Peak to average power ratio limit	
	Probability, %	dB
3550.0 – 3700.0	0.1	13.0

### 7.2.2 Test procedure

7.2.2.1 The EUT was set up as shown in Figure 7.2.1, energized and its proper operation was checked.

7.2.2.2 The EUT was adjusted to produce maximum available to the end user RF output power.

7.2.2.3 The peak to average power ratio was measured with power meter as provided in the associated tables and plots.

Figure 7.2.1 Peak-to-average power ratio test setup

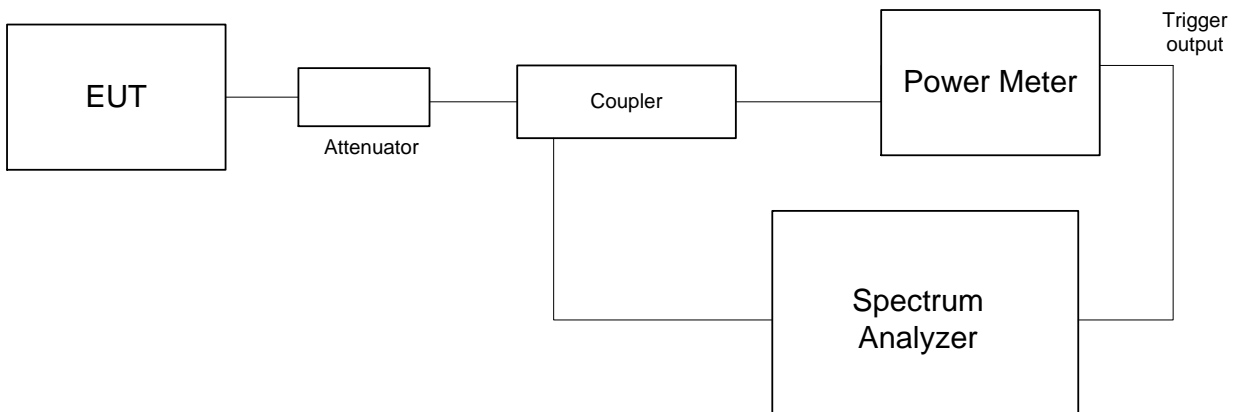



<b>Test specification: Section 96.41(g), Peak-to- average power ratio</b>			
<b>Test procedure:</b> Section 96.41(g)			
<b>Test mode:</b> Compliance		<b>Verdict: PASS</b>	
<b>Date(s):</b> 14-Dec-21			
<b>Temperature:</b> 25 °C	<b>Relative Humidity:</b> 54 %	<b>Air Pressure:</b> 1011 hPa	<b>Power:</b> 48 VDC
<b>Remarks:</b>			

Table 7.2.2 Peak-to-average power ratio test results

OPERATING FREQUENCY RANGE: 3550 – 3700 MHz  
DETECTOR USED: Peak/Average  
MODULATING SIGNAL: PRBS  
TRANSMITTER OUTPUT POWER SETTINGS: Maximum

Carrier frequency, MHz	Peak to average ratio, dB	Limit, dBm	Margin, dB	Verdict
<b>Channel spacing 10 MHz</b>				
<b>Modulation QPSK</b>				
3555.0	8.43	13.0	-4.57	Pass
3625.0	8.35	13.0	-4.65	Pass
3695.0	8.46	13.0	-4.54	Pass
<b>Modulation 16QAM</b>				
3555.0	8.52	13.0	-4.48	Pass
3625.0	8.43	13.0	-4.57	Pass
3695.0	8.49	13.0	-4.51	Pass
<b>Modulation 64QAM</b>				
3555.0	8.46	13.0	-4.54	Pass
3625.0	8.46	13.0	-4.54	Pass
3695.0	8.49	13.0	-4.51	Pass
<b>Modulation 256QAM</b>				
3555.0	8.49	13.0	-4.51	Pass
3625.0	8.49	13.0	-4.51	Pass
3695.0	8.49	13.0	-4.51	Pass

Reference numbers of test equipment used

HL 3301	HL 3901	HL 4355				
---------	---------	---------	--	--	--	--

Full description is given in Appendix A.





HERMON LABORATORIES

<b>Test specification:</b> Section 96.41(g), Peak-to- average power ratio			
<b>Test procedure:</b> Section 96.41(g)			
<b>Test mode:</b> Compliance		<b>Verdict:</b> PASS	
<b>Date(s):</b> 14-Dec-21			
<b>Temperature:</b> 25 °C	<b>Relative Humidity:</b> 54 %	<b>Air Pressure:</b> 1011 hPa	<b>Power:</b> 48 VDC
<b>Remarks:</b>			

Table 7.2.3 Peak-to-average power ratio test results

OPERATING FREQUENCY RANGE: 3550 – 3700 MHz  
 DETECTOR USED: Peak/Average  
 TRANSMITTER OUTPUT POWER SETTINGS: Maximum

Carrier frequency, MHz	Peak to average ratio, dB	Limit, dBm	Margin, dB	Verdict
<b>Channel spacing 30 MHz</b>				
<b>Modulation QPSK</b>				
3565.0	9.47	13.0	-3.53	Pass
3625.0	9.46	13.0	-3.54	Pass
3685.0	9.50	13.0	-3.50	Pass
<b>Modulation 16QAM</b>				
3565.0	9.37	13.0	-3.63	Pass
3625.0	9.33	13.0	-3.67	Pass
3685.0	9.37	13.0	-3.63	Pass
<b>Modulation 64QAM</b>				
3565.0	9.40	13.0	-3.60	Pass
3625.0	9.35	13.0	-3.65	Pass
3685.0	9.35	13.0	-3.65	Pass
<b>Modulation 256QAM</b>				
3565.0	9.39	13.0	-3.61	Pass
3625.0	9.34	13.0	-3.66	Pass
3685.0	9.35	13.0	-3.65	Pass

Reference numbers of test equipment used

HL 3301	HL 3901	HL 4355				
---------	---------	---------	--	--	--	--

Full description is given in Appendix A.



HERMON LABORATORIES

<b>Test specification:</b> Section 96.41(g), Peak-to- average power ratio			
<b>Test procedure:</b> Section 96.41(g)			
<b>Test mode:</b> Compliance		<b>Verdict:</b> PASS	
<b>Date(s):</b> 14-Dec-21			
<b>Temperature:</b> 25 °C	<b>Relative Humidity:</b> 54 %	<b>Air Pressure:</b> 1011 hPa	<b>Power:</b> 48 VDC
<b>Remarks:</b>			

Plot 7.2.1 Peak-to-average power ratio test results at low frequency

CHANNEL SPACING:  
ANTENNA PORT:  
Modulation: QPSK

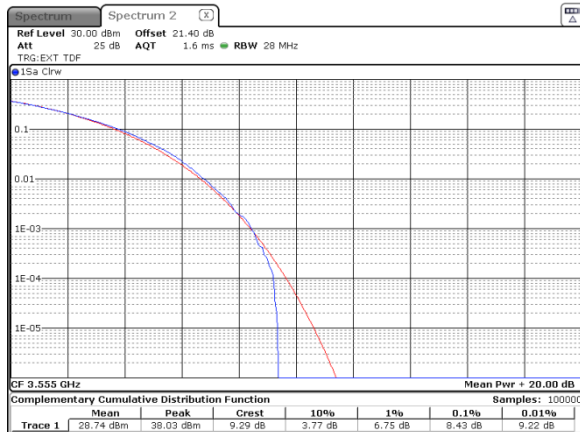

10 MHz  
1  
Modulation: 16QAM



Modulation: 64QAM

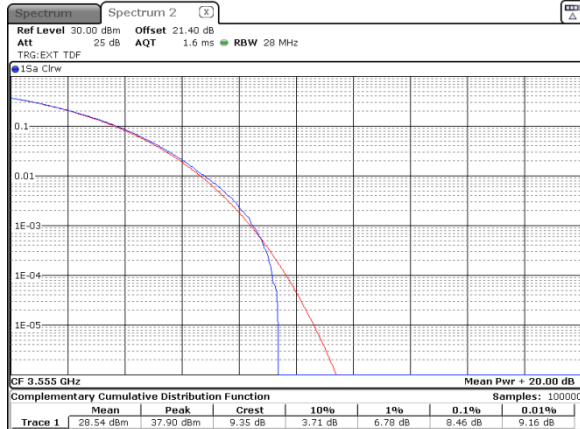

Modulation: 256QAM

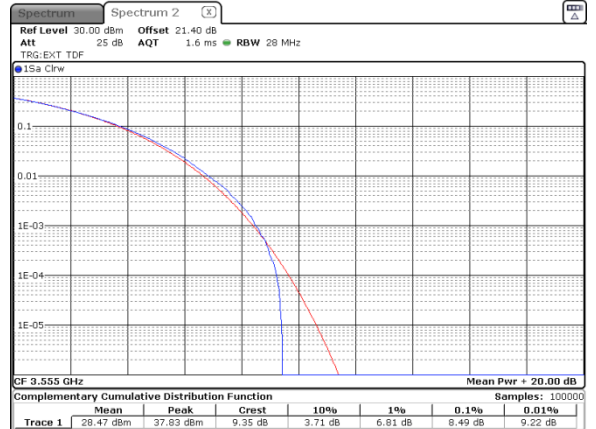



HERMON LABORATORIES

<b>Test specification:</b> Section 96.41(g), Peak-to- average power ratio			
<b>Test procedure:</b> Section 96.41(g)			
<b>Test mode:</b> Compliance		<b>Verdict:</b> PASS	
<b>Date(s):</b> 14-Dec-21			
<b>Temperature:</b> 25 °C	<b>Relative Humidity:</b> 54 %	<b>Air Pressure:</b> 1011 hPa	<b>Power:</b> 48 VDC
<b>Remarks:</b>			

Plot 7.2.2 Peak-to-average power ratio test results at mid frequency

CHANNEL SPACING:  
ANTENNA PORT:  
**Modulation: QPSK**

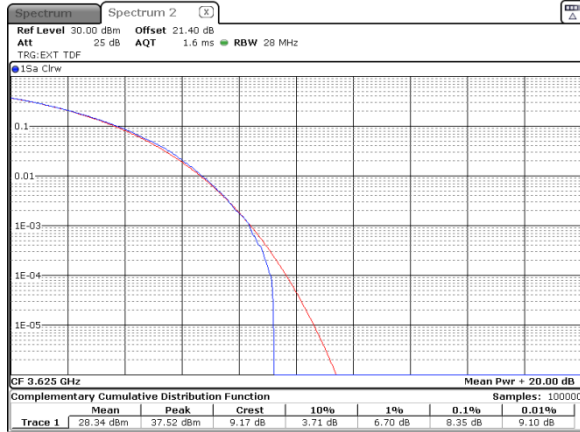

10 MHz  
1  
**Modulation: 16QAM**



**Modulation: 64QAM**

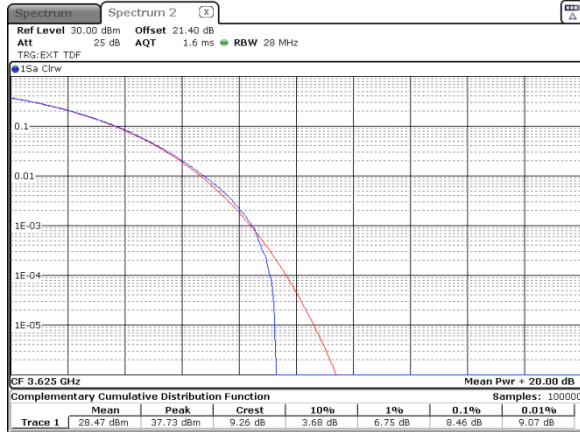

**Modulation: 256QAM**





HERMON LABORATORIES

<b>Test specification:</b> Section 96.41(g), Peak-to-average power ratio			
<b>Test procedure:</b> Section 96.41(g)			
<b>Test mode:</b> Compliance		<b>Verdict:</b> PASS	
<b>Date(s):</b> 14-Dec-21			
<b>Temperature:</b> 25 °C	<b>Relative Humidity:</b> 54 %	<b>Air Pressure:</b> 1011 hPa	<b>Power:</b> 48 VDC
<b>Remarks:</b>			

Plot 7.2.3 Peak-to-average power ratio test results at high frequency

CHANNEL SPACING:  
ANTENNA PORT:  
Modulation: QPSK

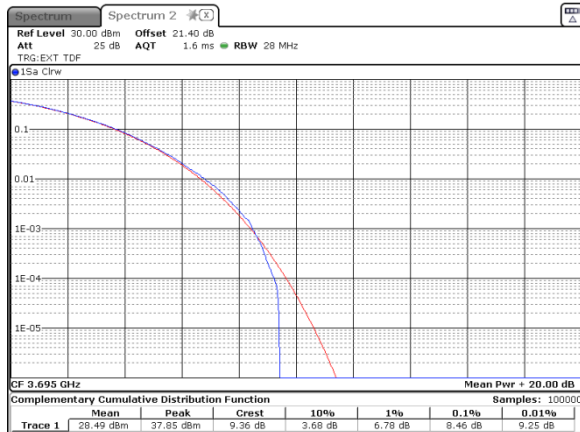

10 MHz  
1  
Modulation: 16QAM

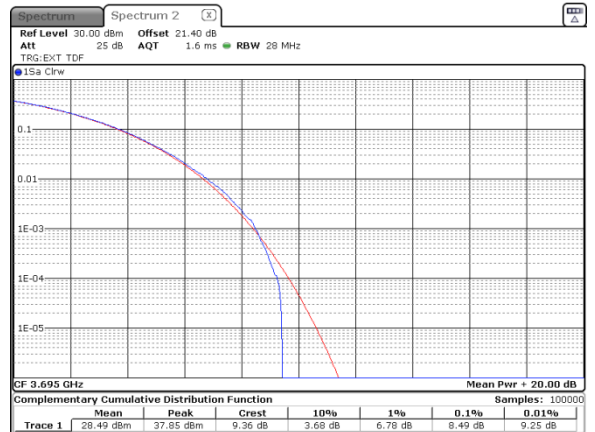

Modulation: 64QAM

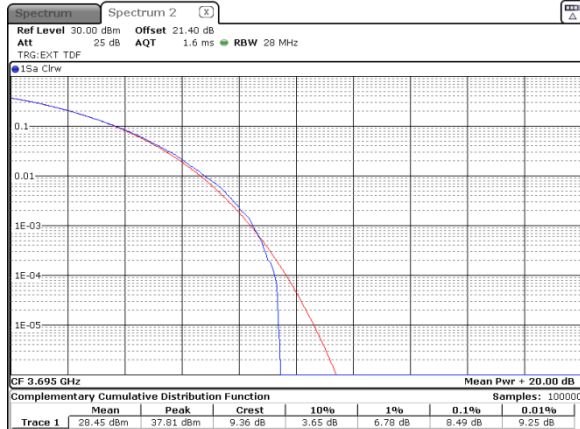

Modulation: 256QAM

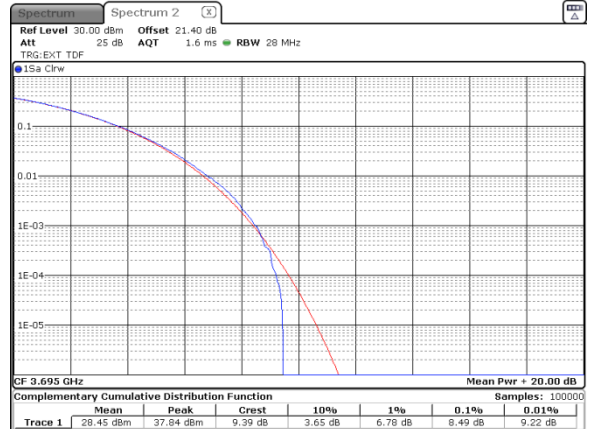



HERMON LABORATORIES

<b>Test specification:</b> Section 96.41(g), Peak-to- average power ratio			
<b>Test procedure:</b> Section 96.41(g)			
<b>Test mode:</b> Compliance		<b>Verdict:</b> PASS	
<b>Date(s):</b> 14-Dec-21			
<b>Temperature:</b> 25 °C	<b>Relative Humidity:</b> 54 %	<b>Air Pressure:</b> 1011 hPa	<b>Power:</b> 48 VDC
<b>Remarks:</b>			

Plot 7.2.4 Peak-to-average power ratio test results at low frequency

CHANNEL SPACING:  
ANTENNA PORT:  
Modulation: QPSK

30 MHz  
1

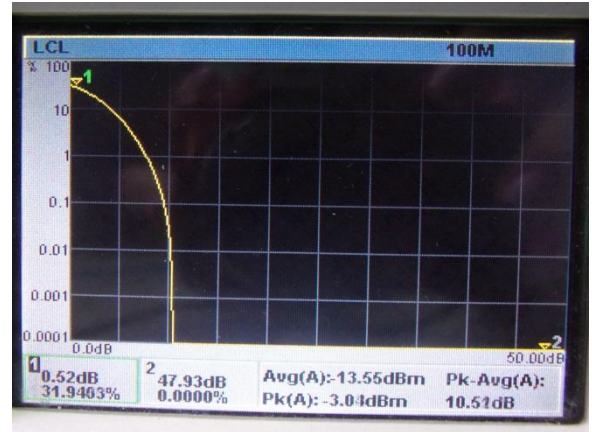
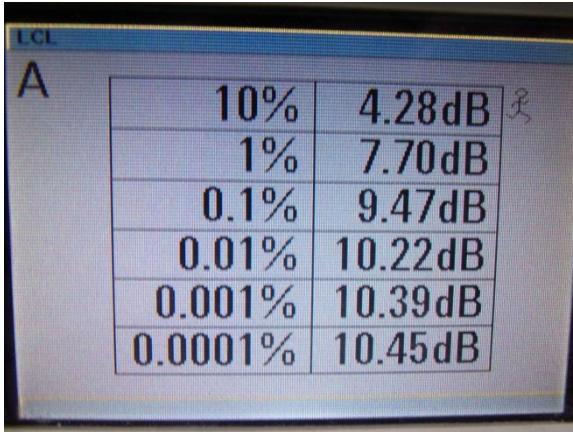

Modulation: 16QAM

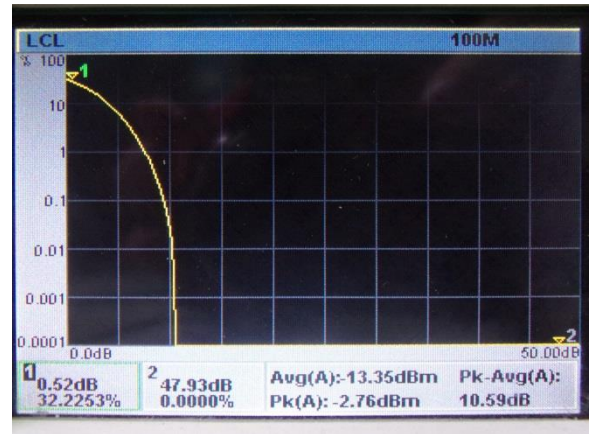
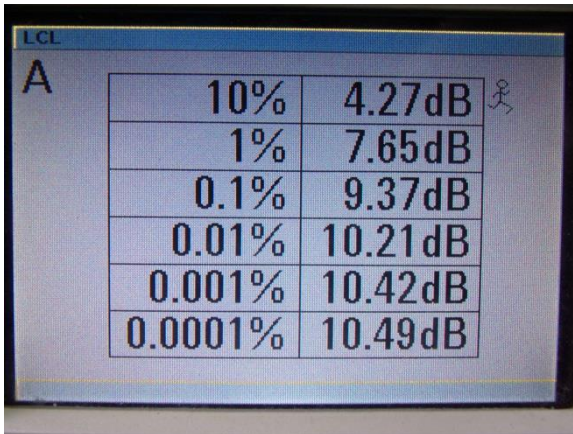





HERMON LABORATORIES

<b>Test specification: Section 96.41(g), Peak-to- average power ratio</b>			
<b>Test procedure:</b> Section 96.41(g)			
<b>Test mode:</b> Compliance		<b>Verdict: PASS</b>	
<b>Date(s):</b> 14-Dec-21			
<b>Temperature:</b> 25 °C	<b>Relative Humidity:</b> 54 %	<b>Air Pressure:</b> 1011 hPa	<b>Power:</b> 48 VDC
<b>Remarks:</b>			

Modulation: 64QAM

LCL

A

10%	4.28dB
1%	7.69dB
0.1%	9.40dB
0.01%	10.25dB
0.001%	10.43dB
0.0001%	10.50dB

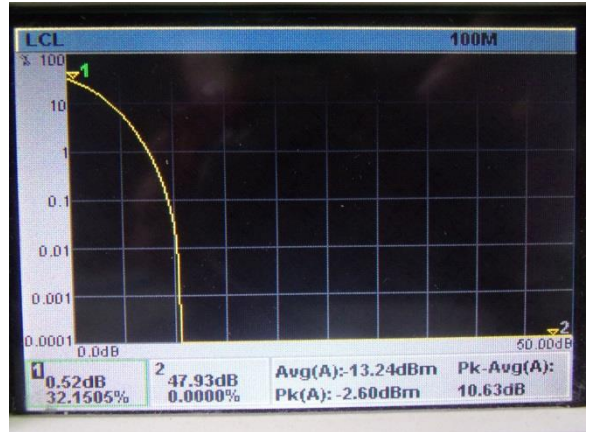

Modulation: 256QAM

LCL

A

10%	4.28dB
1%	7.66dB
0.1%	9.39dB
0.01%	10.22dB
0.001%	10.42dB
0.0001%	10.49dB





HERMON LABORATORIES

<b>Test specification:</b> Section 96.41(g), Peak-to-average power ratio			
<b>Test procedure:</b> Section 96.41(g)			
<b>Test mode:</b> Compliance		<b>Verdict:</b> PASS	
<b>Date(s):</b> 14-Dec-21			
<b>Temperature:</b> 25 °C	<b>Relative Humidity:</b> 54 %	<b>Air Pressure:</b> 1011 hPa	<b>Power:</b> 48 VDC
<b>Remarks:</b>			

Plot 7.2.5 Peak-to-average power ratio test results at mid frequency

CHANNEL SPACING:

30 MHz

ANTENNA PORT:

1

Modulation: QPSK

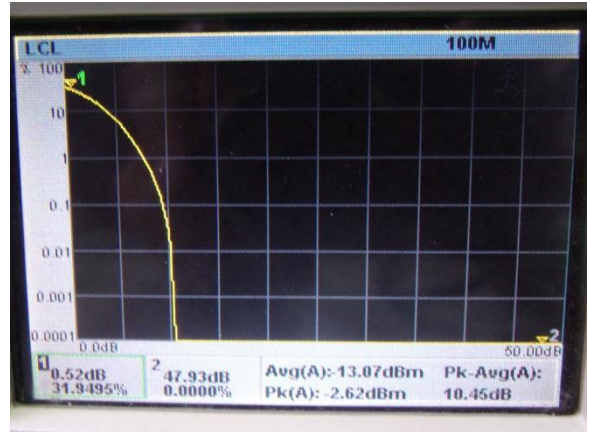
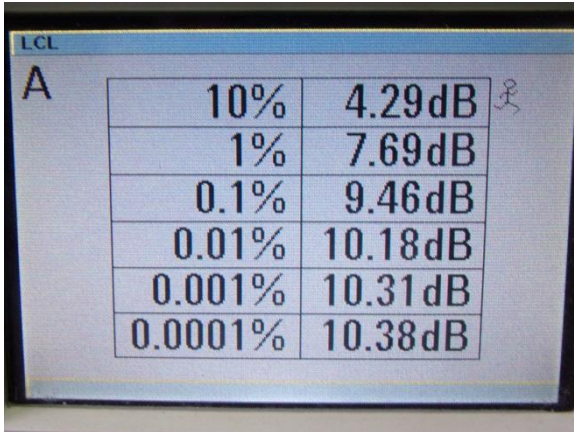

Modulation: 16QAM

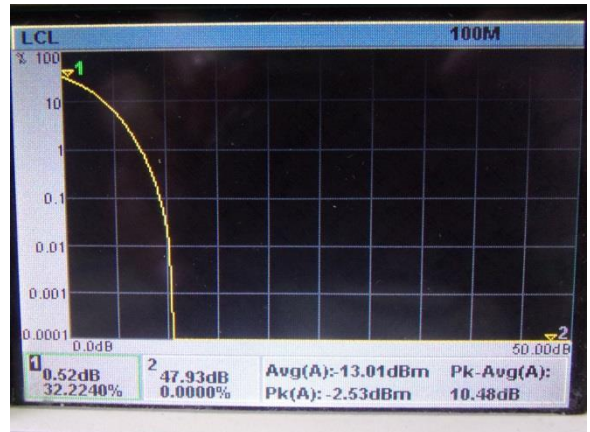
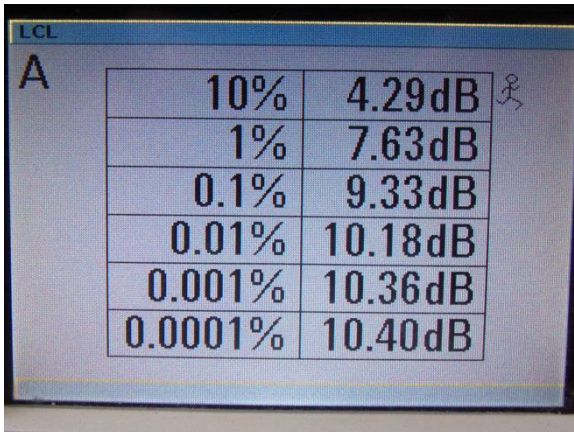





HERMON LABORATORIES

<b>Test specification:</b> Section 96.41(g), Peak-to- average power ratio			
<b>Test procedure:</b> Section 96.41(g)			
<b>Test mode:</b> Compliance		<b>Verdict:</b> PASS	
<b>Date(s):</b> 14-Dec-21			
<b>Temperature:</b> 25 °C	<b>Relative Humidity:</b> 54 %	<b>Air Pressure:</b> 1011 hPa	<b>Power:</b> 48 VDC
<b>Remarks:</b>			

Modulation: 64QAM

A	10%	4.28dB	ⓧ
	1%	7.63dB	
	0.1%	9.35dB	
	0.01%	10.19dB	
	0.001%	10.35dB	
	0.0001%	10.41dB	

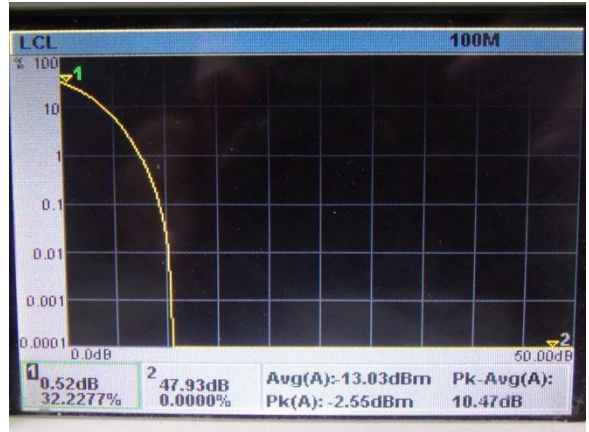

Modulation: 256QAM

A	10%	4.29dB	ⓧ
	1%	7.63dB	
	0.1%	9.34dB	
	0.01%	10.18dB	
	0.001%	10.35dB	
	0.0001%	10.41dB	

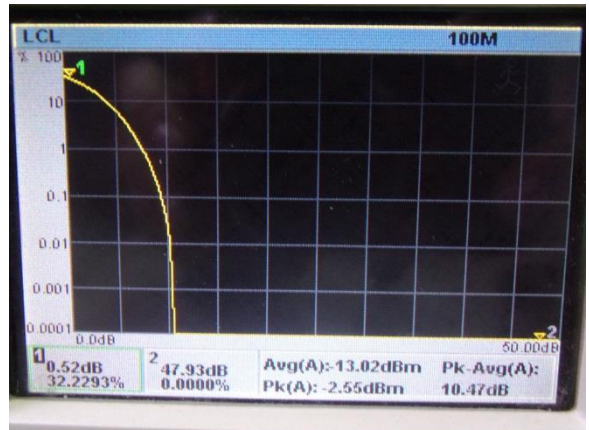





HERMON LABORATORIES

<b>Test specification:</b> Section 96.41(g), Peak-to- average power ratio			
<b>Test procedure:</b> Section 96.41(g)			
<b>Test mode:</b> Compliance		<b>Verdict:</b> PASS	
<b>Date(s):</b> 14-Dec-21			
<b>Temperature:</b> 25 °C	<b>Relative Humidity:</b> 54 %	<b>Air Pressure:</b> 1011 hPa	<b>Power:</b> 48 VDC
<b>Remarks:</b>			

**Plot 7.2.6 Peak-to-average power ratio test results at high frequency**

CHANNEL SPACING:

30 MHz

ANTENNA PORT:

1

**Modulation: QPSK**

LCL		
A	10%	4.30dB
	1%	7.75dB
	0.1%	9.50dB
	0.01%	10.26dB
	0.001%	10.49dB
	0.0001%	10.56dB

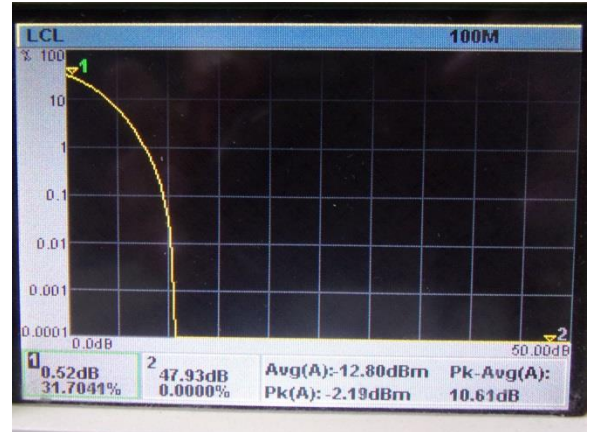

**Modulation: 16QAM**

LCL		
A	10%	4.30dB
	1%	7.66dB
	0.1%	9.37dB
	0.01%	10.22dB
	0.001%	10.45dB
	0.0001%	10.52dB

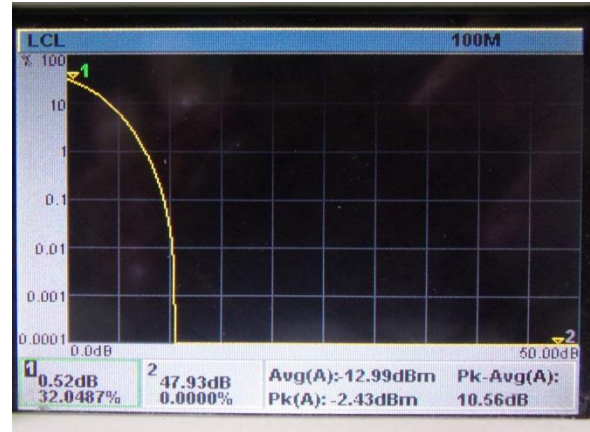



HERMON LABORATORIES

<b>Test specification: Section 96.41(g), Peak-to- average power ratio</b>			
<b>Test procedure:</b> Section 96.41(g)			
<b>Test mode:</b> Compliance		<b>Verdict: PASS</b>	
<b>Date(s):</b> 14-Dec-21			
<b>Temperature:</b> 25 °C	<b>Relative Humidity:</b> 54 %	<b>Air Pressure:</b> 1011 hPa	<b>Power:</b> 48 VDC
<b>Remarks:</b>			

Modulation: 64QAM

LCL

A

10%	4.29dB	✍️
1%	7.65dB	
0.1%	9.35dB	
0.01%	10.22dB	
0.001%	10.44dB	
0.0001%	10.51dB	

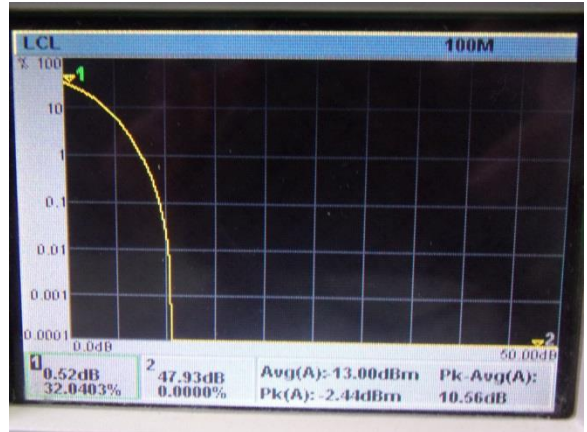

Modulation: 256QAM

LCL

A

10%	4.29dB	✍️
1%	7.65dB	
0.1%	9.35dB	
0.01%	10.21dB	
0.001%	10.45dB	
0.0001%	10.50dB	

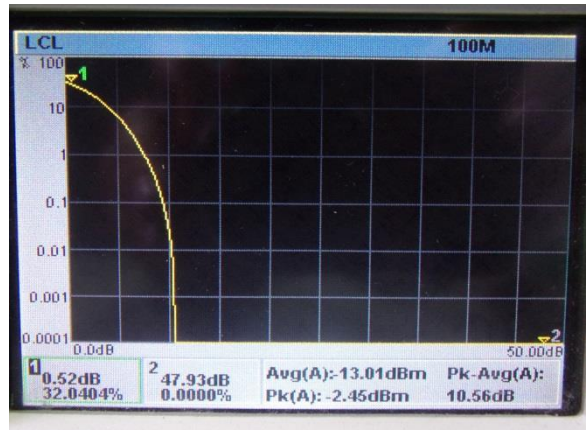



<b>Test specification: Section 2.1049, Occupied bandwidth</b>			
<b>Test procedure:</b> 47 CFR, Section 2.1049			
<b>Test mode:</b> Compliance		<b>Verdict: PASS</b>	
<b>Date(s):</b> 5-Dec-21			
<b>Temperature:</b> 25 °C	<b>Relative Humidity:</b> 54 %	<b>Air Pressure:</b> 1010 hPa	<b>Power:</b> 48 VDC
<b>Remarks:</b>			

### 7.3 Occupied bandwidth test

#### 7.3.1 General

This test was performed to measure transmitter occupied bandwidth. Specification test limits are given in Table 7.3.1.

Table 7.3.1 Occupied bandwidth limits

Assigned frequency, MHz	Modulation envelope reference points*, %	Maximum allowed bandwidth, MHz
3550 - 3700	99	10 / 30 MHz

\* - Modulation envelope reference points are provided in terms of attenuation below the unmodulated carrier.

#### 7.3.2 Test procedure

7.3.2.1 The EUT was set up as shown in Figure 7.3.1, energized and its proper operation was checked.

7.3.2.2 The EUT was set to transmit the unmodulated carrier and the reference peak power level was measured.

7.3.2.3 The EUT was set to transmit the normally modulated carrier.

7.3.2.4 The transmitter occupied bandwidth was measured with spectrum analyzer as a frequency delta between the reference points on modulation envelope and provided in Table 7.3.2 and the associated plots.

Figure 7.3.1 Occupied bandwidth test setup

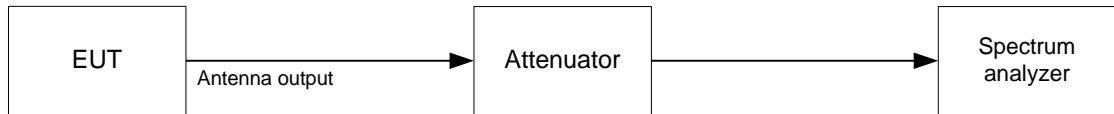



<b>Test specification: Section2.1049, Occupied bandwidth</b>			
<b>Test procedure:</b> 47 CFR, Section 2.1049			
<b>Test mode:</b> Compliance		<b>Verdict: PASS</b>	
<b>Date(s):</b> 5-Dec-21			
<b>Temperature:</b> 25 °C	<b>Relative Humidity:</b> 54 %	<b>Air Pressure:</b> 1010 hPa	<b>Power:</b> 48 VDC
<b>Remarks:</b>			

Table 7.3.2 Occupied bandwidth test results

DETECTOR USED: Peak hold  
RESOLUTION BANDWIDTH: 1 – 5% of the OBW  
VIDEO BANDWIDTH: > RBW  
MODULATION ENVELOPE REFERENCE POINTS: 99%

Carrier frequency, MHz	Occupied bandwidth, MHz	Limit, MHz	Margin, MHz	Verdict
<b>Channel spacing 10 MHz</b>				
<b>Modulation QPSK</b>				
3555.0	8.6764	10.0	-1.3236	Pass
3625.0	8.6689	10.0	-1.3311	Pass
3695.0	8.6514	10.0	-1.3486	Pass
<b>Modulation 16QAM</b>				
3555.0	8.6339	10.0	-1.3661	Pass
3625.0	8.6664	10.0	-1.3336	Pass
3695.0	8.6439	10.0	-1.3561	Pass
<b>Modulation 64QAM</b>				
3555.0	8.6264	10.0	-1.3736	Pass
3625.0	8.6614	10.0	-1.3386	Pass
3680.0	8.6739	10.0	-1.3261	Pass
<b>Modulation 256QAM</b>				
3555.0	8.6264	10.0	-1.3736	Pass
3625.0	8.6389	10.0	-1.3611	Pass
3695.0	8.6489	10.0	-1.3511	Pass
<b>Channel spacing 30 MHz</b>				
<b>Modulation QPSK</b>				
3.565	27.8215	30.0	-2.1785	Pass
3.625	27.8365	30.0	-2.1635	Pass
3.685	27.8290	30.0	-2.1710	Pass
<b>Modulation 16QAM</b>				
3.565	27.8665	30.0	-2.1335	Pass
3.625	27.8890	30.0	-2.1110	Pass
3.685	27.8890	30.0	-2.1110	Pass
<b>Modulation 64QAM</b>				
3.565	27.8740	30.0	-2.1260	Pass
3.625	27.8740	30.0	-2.1260	Pass
3.685	27.8665	30.0	-2.1335	Pass
<b>Modulation 256QAM</b>				
3.565	27.8815	30.0	-2.1185	Pass
3.625	27.8965	30.0	-2.1035	Pass
3.685	27.8515	30.0	-2.1485	Pass

## Reference numbers of test equipment used

HL 3301	HL 4355	HL 5409	HL 4425				
---------	---------	---------	---------	--	--	--	--

Full description is given in Appendix A.