

TEST REPORT

ACCORDING TO: FCC 47CFR part 27

FOR:

Airspan Networks Inc.

LTE Base Station

Model: AirSpeed 1035, 2.496 – 2.69GHz (B41), CN, SFP, AC

FCC ID: PIDAS1035

This report is in conformity with ISO/IEC 17025. The "A2LA Accredited" symbol endorsement applies only to the tests and calibrations that are listed in the scope of Hermon Laboratories accreditation. The test results relate only to the items tested.
This test report shall not be reproduced in any form except in full with the written approval of Hermon Laboratories Ltd.

Table of contents

1	Applicant information	3
2	Equipment under test attributes	3
3	Manufacturer information	3
4	Test details	3
5	Tests summary	4
6	EUT description	5
6.1	General information	5
6.2	Ports and lines	5
6.3	Support and test equipment	5
6.4	Test configuration	6
6.5	Changes made in the EUT	6
6.6	Transmitter characteristics	7
7	Transmitter tests according to 47CFR part 27	8
7.1	Occupied bandwidth test	8
7.2	Maximum EIRP and maximum power spectral density	16
7.3	Band edge emissions at RF connector test	47
7.4	Spurious emissions at RF antenna connector test	56
7.5	Radiated spurious emission measurements	106
7.6	Frequency stability test	116
8	APPENDIX A Test equipment and ancillaries used for tests	118
9	APPENDIX B Test equipment correction factors	120
10	APPENDIX C Measurement uncertainties	123
11	APPENDIX D Test facility description	124
12	APPENDIX E Specification references	124
13	APPENDIX F Abbreviations and acronyms	125
14	APPENDIX G Test equipment correction factors	126

1 Applicant information

Client name: Airspan Networks Inc.
Address: 777 Yamato, Road Suite 310 Boca Raton, FL 33431, USA
Telephone: +972 (3) 3030020
Fax: +972 (3) 9777400
E-mail: oeinem@airspan.com
Contact name: Mr. Oleg Einem

2 Equipment under test attributes

Product name: LTE Base Station
Product type: Transceiver
Model(s): AirSpeed 1035, 2.496 – 2.69GHz (B41), CN, SFP, AC
Serial number: F3D24801FF8C
Hardware version: 03
Software release: SR19.0
Receipt date 21-May-23

3 Manufacturer information

Manufacturer name: Airspan Networks Inc.
Address: 777 Yamato, Road Suite 310 Boca Raton, FL 33431, USA
Telephone: +972 (3) 3030020
Fax: +972 (3) 9777400
E-Mail: oeinem@airspan.com
Contact name: Mr. Oleg Einem

4 Test details



Project ID: 51025
Location: Hermon Laboratories Ltd. 66 HaTachana str., P.O. Box 23, Binyamina 3055001, Israel
Test started: 17-Jul-23
Test completed: 06-Aug-23
Test specification(s): FCC 47CFR part 27

5 Tests summary

Test	Status
Transmitter characteristics	
Section 2.1049, Occupied bandwidth	
Section 27.50(h), Peak output power at RF antenna connector	Pass
Section 27.50(h)(4), Spectral power density	Pass
Section 2.1091, 27.52, RF safety	Pass, exhibit provided in Application for certification
Section 27.53(m)(2), Spurious emissions at RF antenna connector	Pass
Section 27.53(m)(2), Band edge emissions at RF antenna connector	Pass
Section 27.53(m)(2), Radiated spurious emissions	Pass
Section 27.54, Frequency stability	Pass

Testing was completed against all relevant requirements of the test standard. The results obtained indicate that the product under test complies in full with the requirements tested.

The test results relate only to the items tested. Pass/ fail decision was based on nominal values.

	Name and Title	Date	Signature
Tested by:	Mrs. M. Evsuk, test engineer, EMC & Radio	14-Jul-23 – 06-Aug-23	
Reviewed by:	Mrs. S. Peysahov Sheynin, certification specialist, EMC & Radio	08-Aug-23	
Approved by:	Mr. M. Nikishin, group leader, EMC & Radio	11-Aug-23	

6 EUT description

Note: The following data in this clause is provided by the customer and represents his sole responsibility

6.1 General information

The AirSpeed 1035, 2.496 – 2.69GHz (B41), CN, SFP, AC is part of Airspan's carrier-class LTE Advanced outdoor small cell eNodeB family. AirSpeed 1035, 2.496 – 2.69GHz (B41) provides high-speed data, mobility, Voice over LTE, and broadcast/multicast services.

AirSpeed 1035, 2.496 – 2.69GHz (B41) is a super compact, easy to install eNodeB, allowing an operator to deploy LTE broadband services on any Street Furniture, rooftop or building front.

Note: The AirSpeed 1035, 2.496 – 2.69GHz (B41) contains 4 external antennas:

Antennas 1/2 arrange one sector while antenna 1 is cross polarized to antenna 2 and antennas 3/4 arrange another sector while antenna 3 is cross polarized to antenna 4.

The transmitter output signals are completely uncorrelated, antennas 1/2 is one sector and antennas 3/4 is another sector!

6.2 Ports and lines

Port No.	Name	Type	Cable Max. >3m	Cable Shielded	Qty.	Comments
0	ETH	RG45	>3m	v	1	NA
2	RS232	RG45	>3m	v	1	For maintenance
3	SFP port	Optic cable	>3m	-	1	NA
4	GPS	GPS antenna	NA	NA	1	NA
5	RF	RF antenna	NA	NA	4	NA
6	AC power	Power	>3m	-	1	NA

*for maintenance only

6.3 Support and test equipment

Description	Manufacturer	Qty.	Serial number
PC	DELL	Latitude E7440	1
GPS Antenna	Tallysman	32-3372-00-01	1
SFP adapter	Hisense	LTE3409-BC+	1
RF attenuator 30db	A-comm	ASMA10-30dB-6G	4

6.4 Test configuration

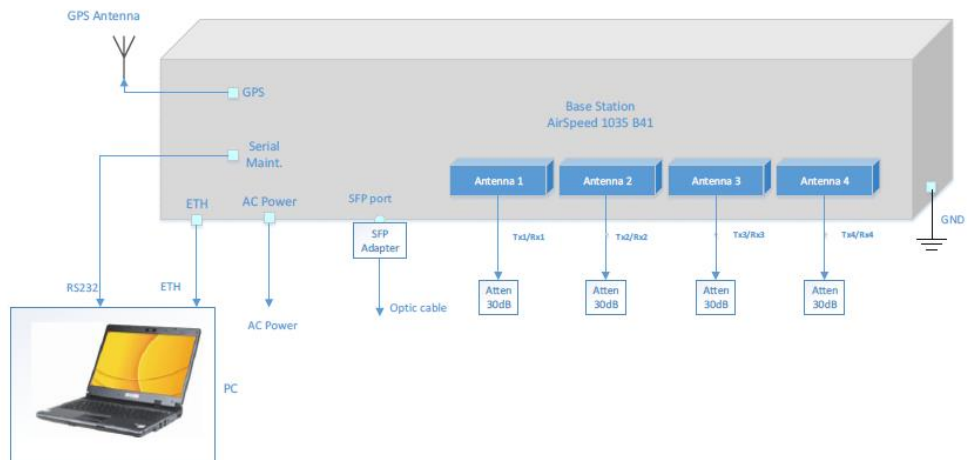

6.5 Changes made in the EUT

No changes were implemented in the EUT during testing.



6.6 Transmitter characteristics

Type of equipment					
V	Stand-alone (Equipment with or without its own control provisions)				
	Combined equipment (Equipment where the radio part is fully integrated within another type of equipment)				
	Plug-in card (Equipment intended for a variety of host systems)				
Intended use		Condition of use			
V	fixed	Always at a distance more than 2 m from all people			
	mobile	Always at a distance more than 20 cm from all people			
	portable	May operate at a distance closer than 20 cm to human body			
Assigned frequency range		2496.0 – 2690.0 MHz			
Operating frequency (full bands)		2501.0 – 2685.0 MHz 2506.0 – 2680.0 MHz			
RF channel spacing		10 MHz, 20 MHz			
Maximum rated output power		At transmitter 50 Ω RF output connector (aggregate power of both RF chains)	35.36 dBm		
Is transmitter output power variable?		No			
		V	Yes		
			continuous variable		
			stepped variable with step size	0.25 dB	
	minimum RF power	-30 dBm			
	maximum RF power at antenna connector	36 dBm			
Antenna connection					
unique coupling	V	standard connector	Integral V with temporary RF connector without temporary RF connector		
Antenna/s technical characteristics					
Type	Manufacturer	Model number	Gain		
Internal, sector antenna	ALPHA Wireless Ltd	AW3007-1	18 dBi		
Internal, sector antenna	ALPHA Wireless Ltd	AW3007-2	18 dBi		
Internal, sector antenna	ALPHA Wireless Ltd	AW3007-3	18 dBi		
Internal, sector antenna	ALPHA Wireless Ltd	AW3007-4	18 dBi		
Transmitter aggregate data rate/s, MBps					
Transmitter 26dBc power bandwidth		Type of modulation			
		QPSK	16QAM	64QAM	256QAM
10 MHz		10.7	22.7	47.3	71.5
20 MHz		23.4	45.4	95.0	143.0
Type of multiplexing		TDD			
Modulating test signal (baseband)		PRBS			
Maximum transmitter duty cycle in normal use		0.74			
Transmitter power source					
		Nominal rated voltage	Battery type		
	DC	Nominal rated voltage			
V	AC mains	Nominal rated voltage	100-240VAC	Frequency 50/60Hz	
Common power source for transmitter and receiver		V	yes	no	



Test specification: Section 2.1049, Occupied bandwidth			
Test procedure: 47 CFR, Section 2.1049			
Test mode: Compliance		Verdict: PASS	
Date(s): 06-Aug-23			
Temperature: 21 °C	Relative Humidity: 54 %	Air Pressure: 1012 hPa	Power: 110 VAC, 60 Hz
Remarks:			

7 Transmitter tests according to 47CFR part 27

7.1 Occupied bandwidth test

7.1.1 General

This test was performed to measure transmitter occupied bandwidth. Specification test limits are given in Table 7.1.1.

Table 7.1.1 Occupied bandwidth limits

Assigned frequency, MHz	Modulation envelope reference points*, %	Maximum allowed bandwidth, kHz
2496.0 – 2690.0	99%	10, 20 MHz

* - Modulation envelope reference points are provided in terms of attenuation below the unmodulated carrier.

7.1.2 Test procedure

7.1.2.1 The EUT was set up as shown in Figure 7.1.1, energized and its proper operation was checked.

7.1.2.2 The EUT was set to transmit the unmodulated carrier and the reference peak power level was measured.

7.1.2.3 The EUT was set to transmit the normally modulated carrier.

7.1.2.4 The transmitter occupied bandwidth was measured with spectrum analyzer as a frequency delta between the reference points on modulation envelope and provided in Table 7.1.2 and the associated plots.

Figure 7.1.1 Occupied bandwidth test setup

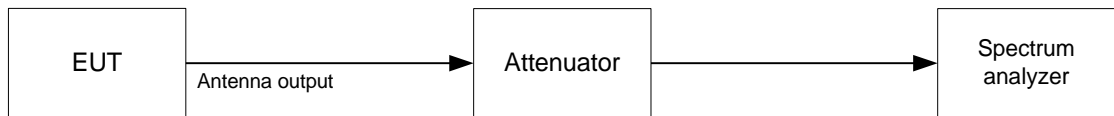



HERMON LABORATORIES

Test specification: Section 2.1049, Occupied bandwidth			
Test procedure: 47 CFR, Section 2.1049			
Test mode: Compliance		Verdict: PASS	
Date(s): 06-Aug-23			
Temperature: 21 °C	Relative Humidity: 54 %	Air Pressure: 1012 hPa	Power: 110 VAC, 60 Hz
Remarks:			

Table 7.1.2 Occupied bandwidth test results

DETECTOR USED: Peak
RESOLUTION BANDWIDTH: 200 kHz
MODULATION ENVELOPE REFERENCE POINTS: 26 dBc; 99%
EBW: 10 MHz

Carrier frequency, MHz	OBW 26 dBc, MHz	OBW 99%. MHz	Limit, kHz	Verdict
QPSK				
2501.0	9.626	8.955	10.0	Pass
2593.0	9.634	8.953	10.0	Pass
2685.0	9.694	8.972	10.0	Pass
256QAM				
2501.0	9.657	8.945	10.0	Pass
2593.0	9.676	8.940	10.0	Pass
2685.0	9.682	8.946	10.0	Pass

DETECTOR USED: Peak
RESOLUTION BANDWIDTH: 390 kHz
MODULATION ENVELOPE REFERENCE POINTS: 26 dBc; 99%
EBW: 20 MHz

Carrier frequency, MHz	OBW 26 dBc, MHz	OBW 99%. MHz	Limit, kHz	Verdict
QPSK				
2506.0	19.24	17.919	20.0	Pass
2593.0	19.27	17.953	20.0	Pass
2680.0	19.18	17.933	20.0	Pass
256QAM				
2506.0	19.25	17.954	20.0	Pass
2593.0	19.30	17.959	20.0	Pass
2680.0	19.34	17.956	20.0	Pass

Reference numbers of test equipment used

HL 5376	HL 5638						
---------	---------	--	--	--	--	--	--

Full description is given in Appendix A.



HERMON LABORATORIES

Test specification: Section 2.1049, Occupied bandwidth			
Test procedure: 47 CFR, Section 2.1049			
Test mode: Compliance		Verdict: PASS	
Date(s): 06-Aug-23			
Temperature: 21 °C	Relative Humidity: 54 %	Air Pressure: 1012 hPa	Power: 110 VAC, 60 Hz
Remarks:			

Plot 7.1.1 Occupied bandwidth test results at low frequency, 10 MHz EBW, QPSK

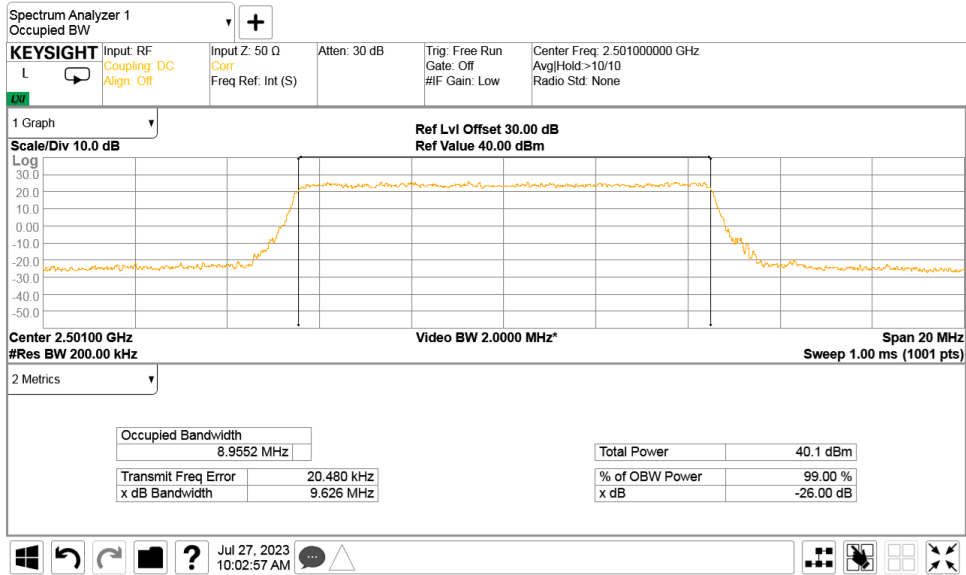

Plot 7.1.2 Occupied bandwidth test results at mid frequency, 10 MHz EBW, QPSK

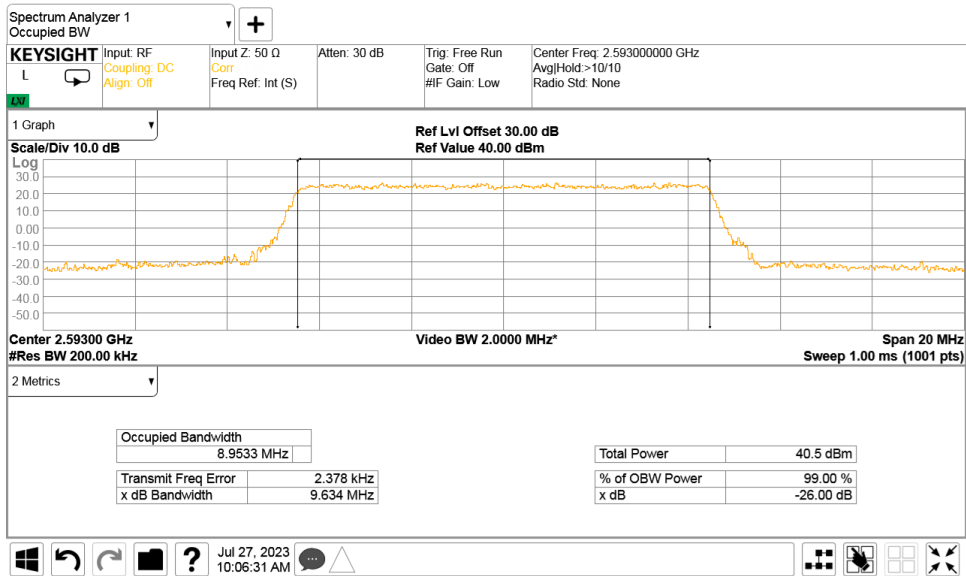



HERMON LABORATORIES

Test specification: Section 2.1049, Occupied bandwidth			
Test procedure: 47 CFR, Section 2.1049			
Test mode: Compliance		Verdict: PASS	
Date(s): 06-Aug-23			
Temperature: 21 °C	Relative Humidity: 54 %	Air Pressure: 1012 hPa	Power: 110 VAC, 60 Hz
Remarks:			

Plot 7.1.3 Occupied bandwidth test results at high frequency, 10 MHz EBW, QPSK

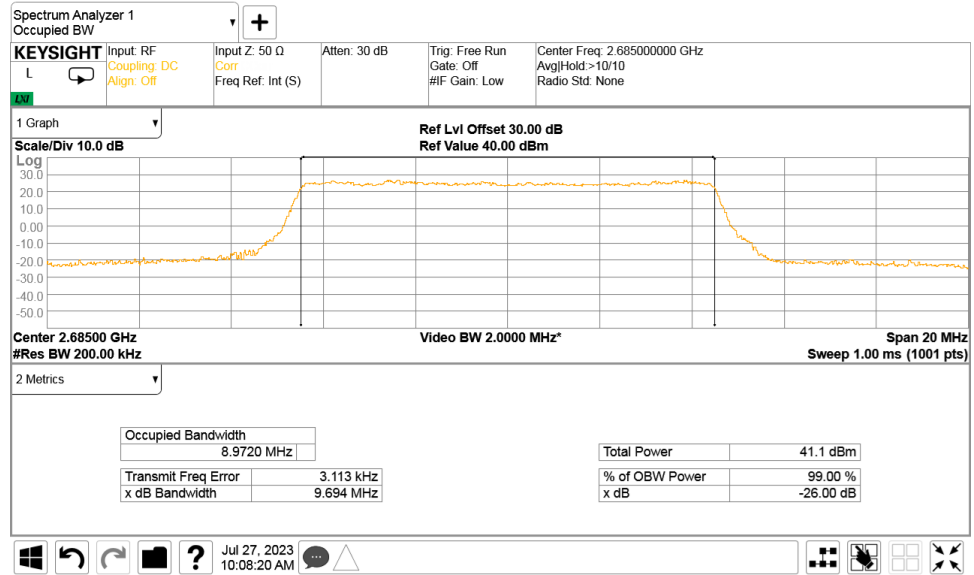

Plot 7.1.4 Occupied bandwidth test results at low frequency, 10 MHz EBW, 256QAM

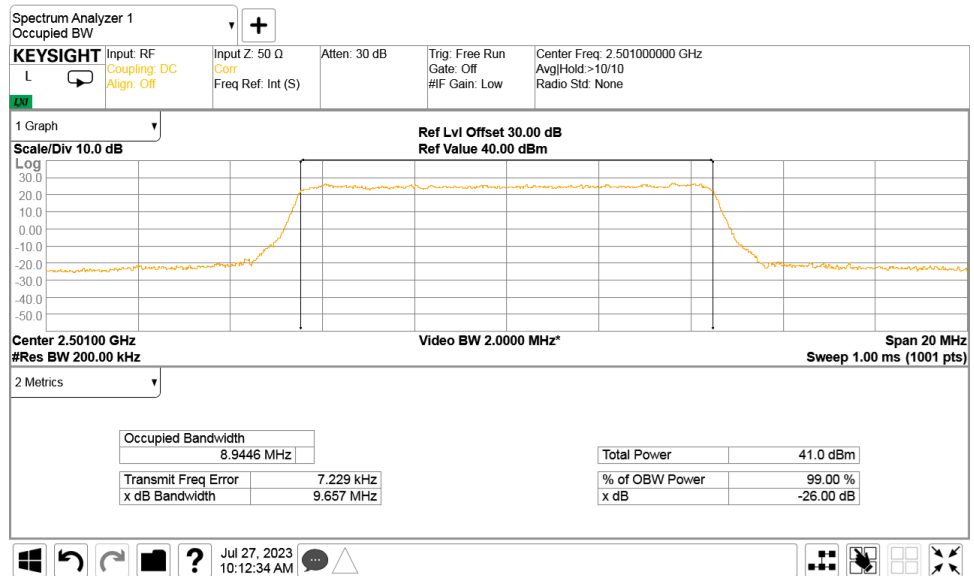



Test specification: Section 2.1049, Occupied bandwidth			
Test procedure: 47 CFR, Section 2.1049			
Test mode: Compliance		Verdict: PASS	
Date(s): 06-Aug-23			
Temperature: 21 °C	Relative Humidity: 54 %	Air Pressure: 1012 hPa	Power: 110 VAC, 60 Hz
Remarks:			

Plot 7.1.5 Occupied bandwidth test results at mid frequency, 10 MHz EBW, 256QAM

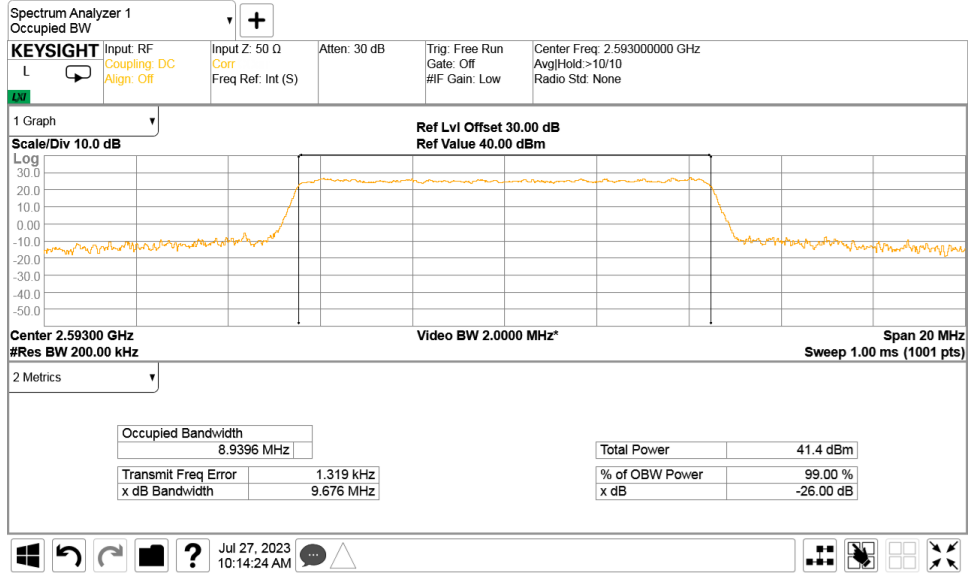

Plot 7.1.6 Occupied bandwidth test results at high frequency, 10 MHz EBW, 256QAM

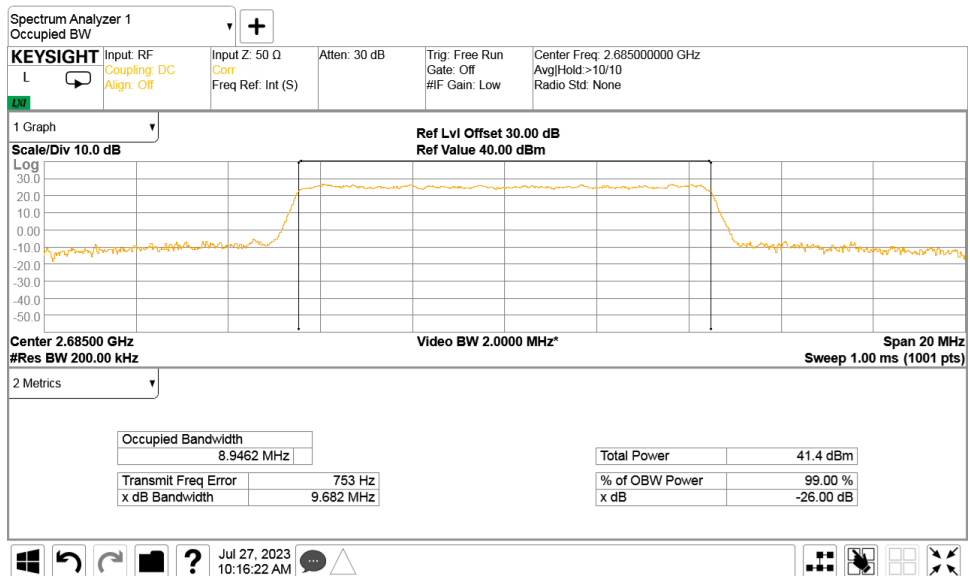



HERMON LABORATORIES

Test specification: Section 2.1049, Occupied bandwidth			
Test procedure: 47 CFR, Section 2.1049			
Test mode: Compliance		Verdict: PASS	
Date(s): 06-Aug-23			
Temperature: 21 °C	Relative Humidity: 54 %	Air Pressure: 1012 hPa	Power: 110 VAC, 60 Hz
Remarks:			

Plot 7.1.7 Occupied bandwidth test results at low frequency, 20 MHz EBW, QPSK

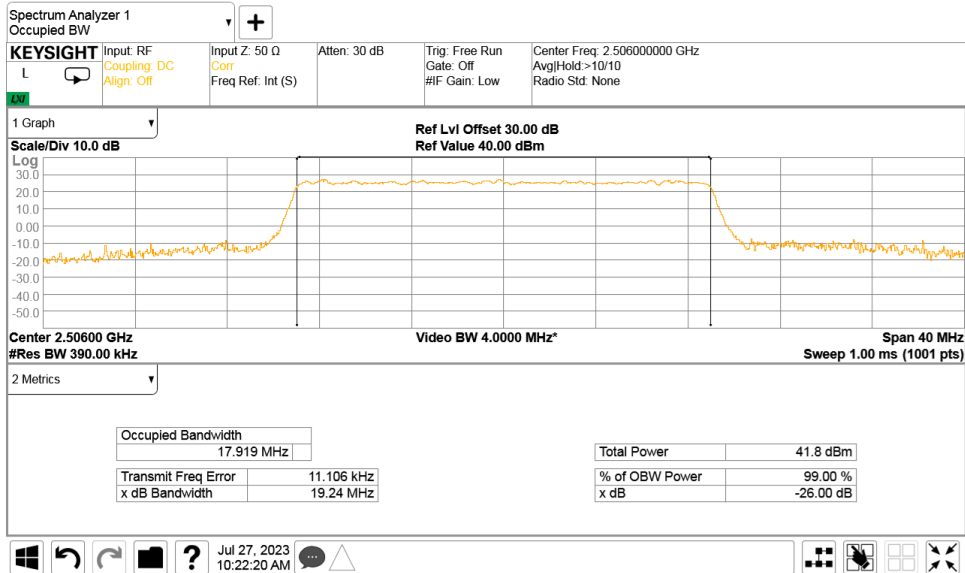

Plot 7.1.8 Occupied bandwidth test results at mid frequency, 20 MHz EBW, QPSK

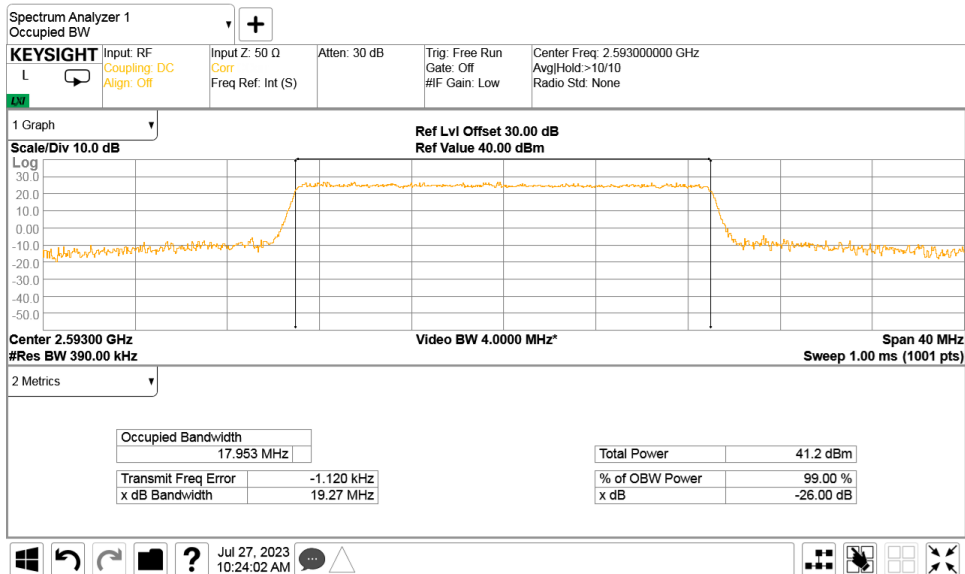



HERMON LABORATORIES

Test specification: Section 2.1049, Occupied bandwidth			
Test procedure: 47 CFR, Section 2.1049			
Test mode: Compliance		Verdict: PASS	
Date(s): 06-Aug-23			
Temperature: 21 °C	Relative Humidity: 54 %	Air Pressure: 1012 hPa	Power: 110 VAC, 60 Hz
Remarks:			

Plot 7.1.9 Occupied bandwidth test results at high frequency, 20 MHz EBW, QPSK

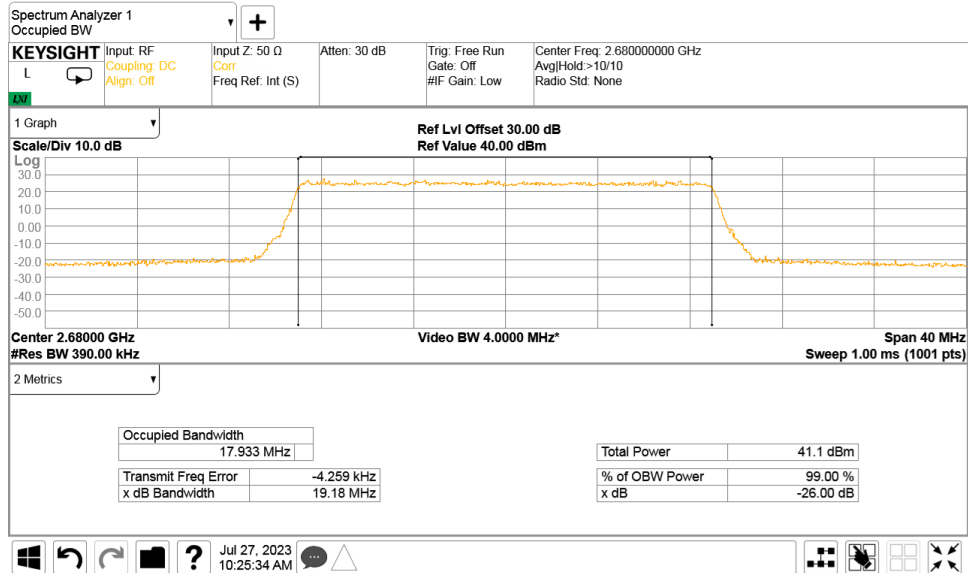

Plot 7.1.10 Occupied bandwidth test results at low frequency, 20 MHz EBW, 256QAM

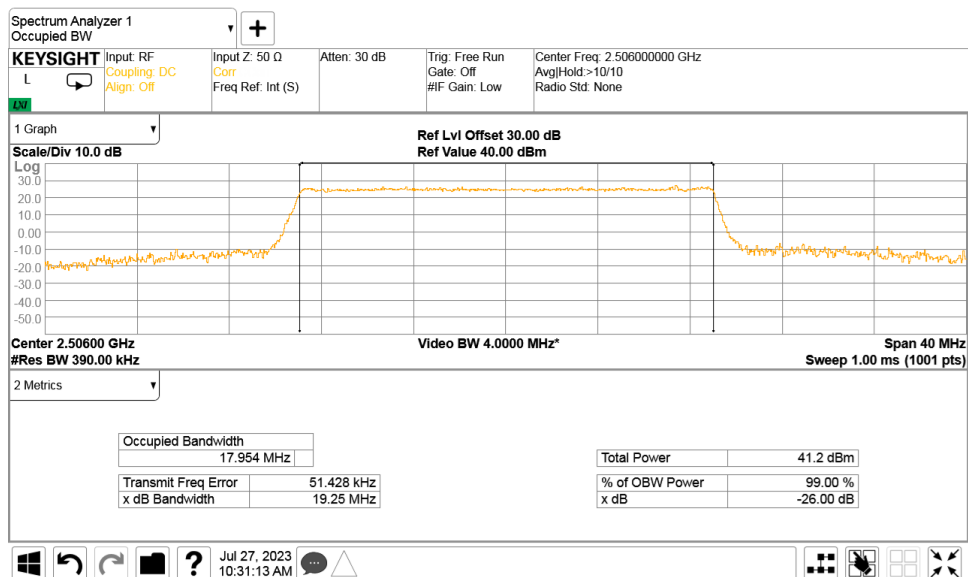



HERMON LABORATORIES

Test specification: Section 2.1049, Occupied bandwidth			
Test procedure: 47 CFR, Section 2.1049			
Test mode: Compliance		Verdict: PASS	
Date(s): 06-Aug-23			
Temperature: 21 °C	Relative Humidity: 54 %	Air Pressure: 1012 hPa	Power: 110 VAC, 60 Hz
Remarks:			

Plot 7.1.11 Occupied bandwidth test results at mid frequency, 20 MHz EBW, 256QAM

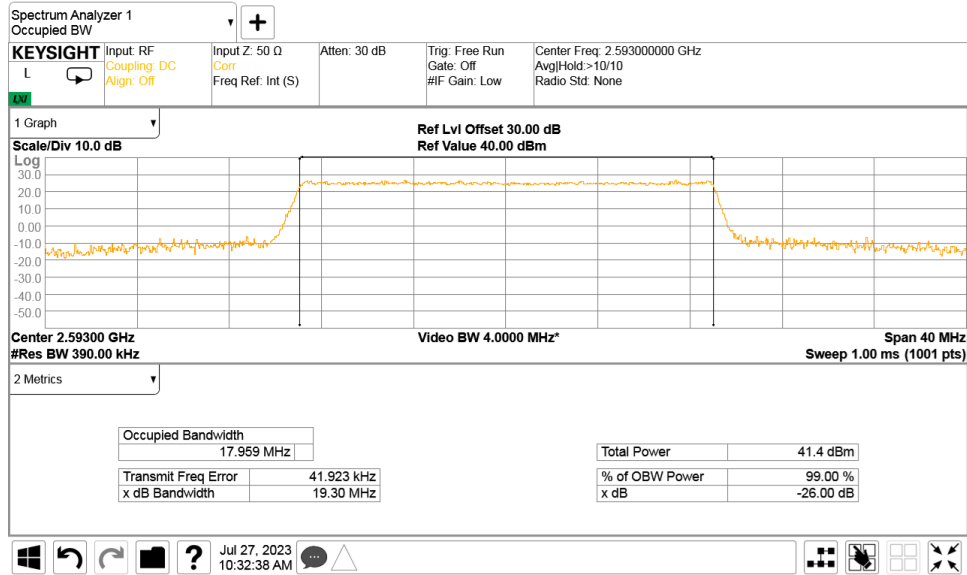

Plot 7.1.12 Occupied bandwidth test results at high frequency, 20 MHz EBW, 256QAM

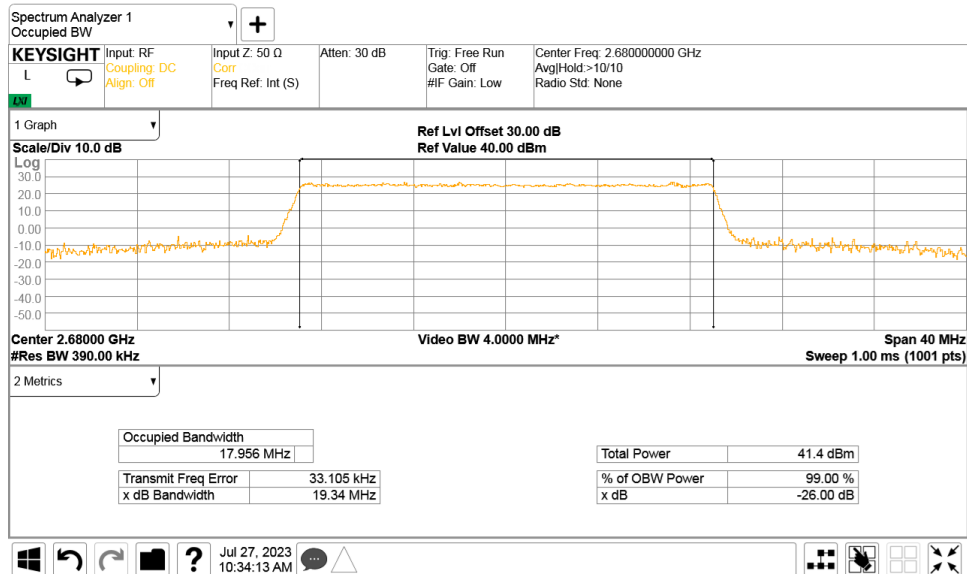



Test specification: Section 27.50, Peak output power			
Test procedure: 47 CFR, Section 2.1046; TIA/EIA-603-E, Section 2.2.1			
Test mode: Compliance		Verdict: PASS	
Date(s): 06-Aug-23			
Temperature: 21 °C	Relative Humidity: 54 %	Air Pressure: 1012 hPa	Power: 110 VAC, 60 Hz
Remarks:			

7.2 Maximum EIRP and maximum power spectral density

7.2.1 General

This test was performed to measure the peak output power at RF antenna connector. Specification test limits are given in Table 7.2.1.

Table 7.2.1 Peak output power limits

Transmitter type	Assigned frequency range, MHz	Maximum peak output power, dBm
Main, booster and base stations	2496.0 – 2690.0	$63+10\log(X/Y)+10\log(360/\text{beamwidth})$
		Maximum peak power density, dBm/100 kHz
		$\text{EIRP}+10\log(0.1/Y)$

*- X is the actual channel width in MHz (occupied bandwidth), Y is either

- 1) 6 MHz if prior to transition or the station is in the MBS following transition or
- 2) 5.5 MHz if the station is in the LBS and UBS following transition, and
- 3) beamwidth is the total horizontal plane beam width of the individual transmitting antenna for the station or any sector measured at the half-power points.

7.2.2 Test procedure

7.2.2.1 The EUT was set up as shown in Figure 7.2.1, energized and its proper operation was checked.

7.2.2.2 The EUT was adjusted to produce maximum available to the end user RF output power.

7.2.2.3 The average output power was measured with power meter as provided in Table 7.2.2.

7.2.2.4 The power spectral density was measured with spectrum analyzer as provided in Table 7.2.3 and the associated plots.

7.2.2.5 The test results are provided in the tables below and associated plots.

Figure 7.2.1 Peak output power test setup

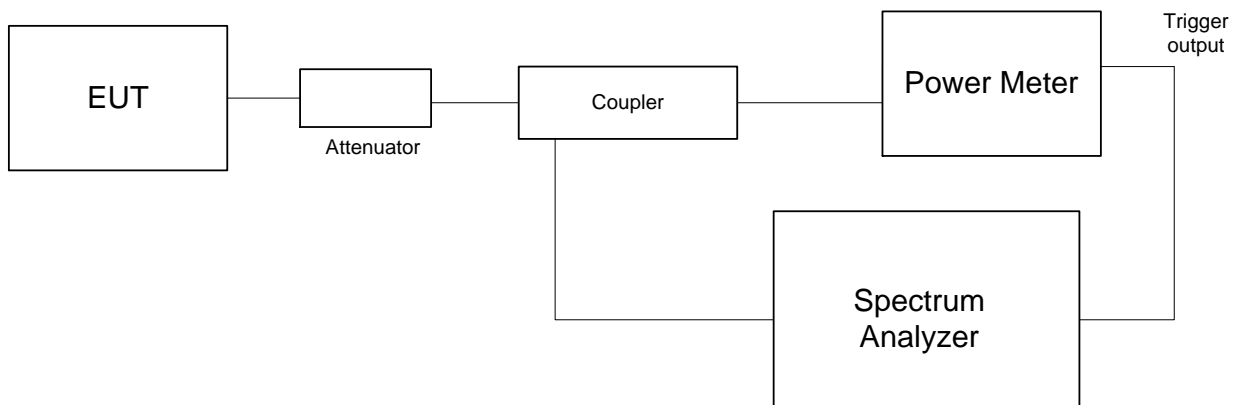



Test specification: Section 27.50, Peak output power			
Test procedure: 47 CFR, Section 2.1046; TIA/EIA-603-E, Section 2.2.1			
Test mode: Compliance		Verdict: PASS	
Date(s): 06-Aug-23			
Temperature: 21 °C	Relative Humidity: 54 %	Air Pressure: 1012 hPa	Power: 110 VAC, 60 Hz
Remarks:			

Table 7.2.2 Maximum EIRP test results

ASSIGNED FREQUENCY RANGE: 2496 - 2690 MHz
 DETECTOR USED: Average (gated)
 VIDEO BANDWIDTH: ≥ Resolution bandwidth
 CHANNEL BANDWIDTH: 10 MHz

Carrier frequency, MHz	Power Meter				Antenna gain, dBi	EIRP*, dBm	Limit, dBm	Margin, dB**	Verdict
	Chain RF#1, dBm	Chain RF#2, dBm	Chain RF#3, dBm	Chain RF#4, dBm					
Modulation QPSK									
2501.0	35.24	35.14	34.90	35.16	18	53.24	69.36	-15.82	Pass
2593.0	35.36	35.17	34.86	35.14	18	53.36	69.48	-16.12	Pass
2685.0	35.01	35.12	34.85	34.90	18	53.12	69.55	-16.43	Pass
Modulation 16QAM									
2501.0	35.20	35.11	35.05	35.27	18	53.27	69.36	-16.09	Pass
2593.0	35.32	35.14	35.09	35.21	18	53.32	69.48	-16.16	Pass
2685.0	35.07	35.08	34.82	34.82	18	53.08	69.55	-16.47	Pass
Modulation 64QAM									
2501.0	35.17	35.09	35.19	35.18	18	53.19	69.36	-16.17	Pass
2593.0	35.34	35.10	35.14	35.23	18	53.34	69.48	-16.14	Pass
2685.0	35.07	35.05	34.88	35.01	18	53.07	69.55	-16.48	Pass
Modulation 256QAM									
2501.0	35.21	35.03	35.05	35.19	18	53.21	69.36	-16.15	Pass
2593.0	35.24	35.02	35.13	35.23	18	53.24	69.48	-16.24	Pass
2685.0	35.01	35.08	34.86	34.75	18	53.08	69.55	-16.47	Pass

* - EIRP = Max SA reading (Chains #1&2 and #3&4) + Antenna gain: The transmitter output signal are completely uncorrelated, antennas 1/2 is one sector and antennas 3/4 is another sector.

** - Margin = EIRP, dBm – specification limit.



Test specification: Section 27.50, Peak output power			
Test procedure: 47 CFR, Section 2.1046; TIA/EIA-603-E, Section 2.2.1			
Test mode: Compliance		Verdict: PASS	
Date(s): 06-Aug-23			
Temperature: 21 °C	Relative Humidity: 54 %	Air Pressure: 1012 hPa	Power: 110 VAC, 60 Hz
Remarks:			

Table 7.2.3 Maximum EIRP test results

ASSIGNED FREQUENCY RANGE: 2496 - 2690 MHz
 DETECTOR USED: Average (gated)
 VIDEO BANDWIDTH: ≥ Resolution bandwidth
 CHANNEL BANDWIDTH: 20 MHz

Carrier frequency, MHz	Power Meter				Antenna gain, dBi	EIRP*, dBm	Limit, dBm	Margin, dB**	Verdict
	Chain RF#1, dBm	Chain RF#2, dBm	Chain RF#3, dBm	Chain RF#4, dBm					
Modulation QPSK									
2506.0	35.06	35.03	34.82	35.13	18	53.13	69.75	-16.62	Pass
2593.0	34.92	34.92	35.04	35.07	18	53.07	69.48	-16.41	Pass
2680.0	34.88	34.93	34.80	35.18	18	53.18	69.84	-16.66	Pass
Modulation 16QAM									
2506.0	35.00	34.98	35.13	35.27	18	53.27	69.75	-16.51	Pass
2593.0	34.99	34.85	35.08	35.33	18	53.33	69.48	-16.15	Pass
2680.0	34.88	34.82	35.03	35.03	18	53.03	69.84	-16.81	Pass
Modulation 64QAM									
2506.0	35.10	34.91	35.09	34.91	18	53.10	69.75	-16.65	Pass
2593.0	34.84	34.88	34.84	34.98	18	52.98	69.48	-16.50	Pass
2680.0	34.91	34.85	34.92	34.90	18	52.92	69.84	-16.92	Pass
Modulation 256QAM									
2506.0	34.99	35.03	35.13	35.03	18	53.13	69.75	-16.82	Pass
2593.0	34.92	34.88	35.10	35.21	18	53.21	69.49	-16.28	Pass
2680.0	34.87	34.92	34.93	35.06	18	53.06	69.87	-16.81	Pass

* - EIRP = Max SA reading (Chains #1&2 and #3&4) + Antenna gain: The transmitter output signal are completely uncorrelated, antennas 1/2 is one sector and antennas 3/4 is another sector.

** - Margin = EIRP, dBm – specification limit.

Reference numbers of test equipment used

HL 3301	HL 3302	HL 4355	HL 4366	HL 5589		
---------	---------	---------	---------	---------	--	--

Full description is given in Appendix A.



Test specification: Section 27.50, Peak output power			
Test procedure: 47 CFR, Section 2.1046; TIA/EIA-603-E, Section 2.2.1			
Test mode: Compliance		Verdict: PASS	
Date(s): 06-Aug-23			
Temperature: 21 °C	Relative Humidity: 54 %	Air Pressure: 1012 hPa	Power: 110 VAC, 60 Hz
Remarks:			

Table 7.2.4 Peak spectral power density test results

ASSIGNED FREQUENCY RANGE: 2496 - 2690 MHz
 DETECTOR USED: Average (gated)
 VIDEO BANDWIDTH: ≥ Resolution bandwidth
 CHANNEL BANDWIDTH: 10 MHz

Carrier frequency, MHz	SA Reading, dBm/MHz				Antenna gain, dBi	EIRP*, dBm/100 kHz	Limit, dBm	Margin**, dB	Verdict
	Chain RF#1, dBm	Chain RF#2, dBm	Chain RF#3, dBm	Chain RF#4, dBm					
Modulation QPSK									
2501.0	15.84	15.79	15.43	15.76	18	33.84	48.75	-14.91	Pass
2593.0	15.76	15.53	15.67	15.68	18	33.76	48.69	-14.93	Pass
2685.0	15.61	15.58	15.47	15.62	18	33.62	49.14	-15.52	Pass
Modulation 16QAM									
2501.0	15.59	15.79	15.77	15.70	18	33.79	48.75	-14.96	Pass
2593.0	15.87	15.78	15.70	15.81	18	33.87	48.69	-14.82	Pass
2685.0	15.61	15.81	15.52	15.46	18	33.81	49.14	-15.33	Pass
Modulation 64QAM									
2501.0	15.65	15.71	15.77	15.73	18	33.77	48.75	-14.98	Pass
2593.0	15.89	15.76	15.60	15.82	18	33.89	48.69	-14.80	Pass
2685.0	15.65	15.77	15.41	15.60	18	33.77	49.14	-15.37	Pass
Modulation 256QAM									
2501.0	15.73	15.36	15.63	15.72	18	33.73	48.75	-15.02	Pass
2593.0	15.72	15.43	15.59	15.60	18	33.72	48.69	-14.97	Pass
2685.0	15.54	15.46	15.34	15.20	18	33.54	49.14	-15.60	Pass

* - Total PSD = Max SA reading (Chains #1&2 or chains #3&4) + Antenna Gain: The transmitter output signal are completely uncorrelated, antennas 1/2 is one sector and antennas 3/4 is another sector.
 ** - Margin = Total PSD, dBm – specification limit.



Test specification: Section 27.50, Peak output power			
Test procedure: 47 CFR, Section 2.1046; TIA/EIA-603-E, Section 2.2.1			
Test mode: Compliance		Verdict: PASS	
Date(s): 06-Aug-23			
Temperature: 21 °C	Relative Humidity: 54 %	Air Pressure: 1012 hPa	Power: 110 VAC, 60 Hz
Remarks:			

Table 7.2.5 Peak spectral power density test results

ASSIGNED FREQUENCY RANGE: 2496 - 2690 MHz
DETECTOR USED: Average (gated)
VIDEO BANDWIDTH: ≥ Resolution bandwidth
CHANNEL BANDWIDTH: 20 MHz

Carrier frequency, MHz	SA Reading, dBm/MHz				Antenna gain, dBi	EIRP*, dBm/100 kHz	Limit, dBm	Margin**, dB	Verdict
	Chain RF#1, dBm	Chain RF#2, dBm	Chain RF#3, dBm	Chain RF#4, dBm					
Modulation QPSK									
2506.0	13.09	13.45	13.29	13.45	18	31.45	46.23	-14.78	Pass
2593.0	13.21	13.10	13.16	13.25	18	31.25	45.68	-14.43	Pass
2680.0	13.24	13.09	12.85	13.34	18	31.34	46.41	-15.07	Pass
Modulation 16QAM									
2506.0	13.05	13.35	13.50	13.57	18	31.57	46.23	-14.66	Pass
2593.0	13.30	13.20	13.20	13.63	18	31.63	45.68	-14.05	Pass
2680.0	13.14	13.19	13.15	13.21	18	31.21	46.42	-15.21	Pass
Modulation 64QAM									
2506.0	13.25	13.34	13.34	13.24	18	31.34	46.23	-14.89	Pass
2593.0	13.36	13.19	13.08	12.99	18	31.36	45.68	-14.32	Pass
2680.0	13.20	13.19	13.23	12.99	18	31.23	46.42	-15.19	Pass
Modulation 256QAM									
2506.0	13.25	13.52	13.66	13.78	18	31.78	46.23	-14.45	Pass
2593.0	13.22	13.23	13.35	13.72	18	31.72	45.68	-13.96	Pass
2680.0	13.11	13.26	13.15	13.46	18	31.46	46.45	-14.99	Pass

* - Total PSD = Max SA reading (Chains #1&2 or chains #3&4) + Antenna Gain: The transmitter output signal are completely uncorrelated, antennas 1/2 is one sector and antennas 3/4 is another sector.

** - Margin = Total PSD, dBm – specification limit.

Reference numbers of test equipment used

HL 3301	HL 3302	HL 4366	HL 5376	HL 5409		
---------	---------	---------	---------	---------	--	--

Full description is given in Appendix A.



Test specification: Section 27.50, Peak output power			
Test procedure: 47 CFR, Section 2.1046; TIA/EIA-603-E, Section 2.2.1			
Test mode: Compliance		Verdict: PASS	
Date(s): 06-Aug-23			
Temperature: 21 °C	Relative Humidity: 54 %	Air Pressure: 1012 hPa	Power: 110 VAC, 60 Hz
Remarks:			

Table 7.2.6 Post - transition frequency channels assignment

Channel	OBW, MHz	Maximum EIRP limit with antenna 12.0 dBi, 65° beamwidth, dBm	
10 MHz QPSK			
2501.0 MHz BRS1+EBS A1	9.626	$63+10\log(\text{OBW}/11.5)+10\log(360/\text{beamwidth})$	69.36
2593.0 MHz EBS C4+D4	9.634	$63+10\log(\text{OBW}/12)+10\log(360/\text{beamwidth})$	69.48
2685.0 MHz EBS G2+G3	9.694	$63+10\log(\text{OBW}/11.0)+10\log(360/\text{beamwidth})$	69.55
10 MHz 256QAM			
2501.0 MHz BRS1+EBS A1	9.657	$63+10\log(\text{OBW}/11.5)+10\log(360/\text{beamwidth})$	69.35
2593.0 MHz EBS C4+D4	9.676	$63+10\log(\text{OBW}/12)+10\log(360/\text{beamwidth})$	69.499
2685.0 MHz EBS G2+G3	9.682	$63+10\log(\text{OBW}/11.0)+10\log(360/\text{beamwidth})$	69.55

Table 7.2.7 Post - transition frequency channels assignment

Channel	OBW, MHz	Maximum EIRP limit with antenna 12.0 dBi, 65° beamwidth, dBm	
20 MHz QPSK			
2506.0 MHz BRS1+EBS A1+A2+A3	19.24	$63+10\log(\text{OBW}/22.5)+10\log(360/\text{beamwidth})$	69.75
2593.0 MHz EBS B4+C4+D4+ G4	19.27	$63+10\log(\text{OBW}/24.0)+10\log(360/\text{beamwidth})$	69.48
2680.0 MHz EBS H3+G1+G2+G3	19.18	$63+10\log(\text{OBW}/22.0)+10\log(360/\text{beamwidth})$	69.84
20 MHz 256QAM			
2506.0 MHz BRS1+EBS A1+A2+A3	19.25	$63+10\log(\text{OBW}/22.5)+10\log(360/\text{beamwidth})$	69.75
2593.0 MHz EBS B4+C4+D4+ G4	19.30	$63+10\log(\text{OBW}/24.0)+10\log(360/\text{beamwidth})$	69.49
2680.0 MHz EBS H3+G1+G2+G3	19.34	$63+10\log(\text{OBW}/22.0)+10\log(360/\text{beamwidth})$	69.87



Test specification: Section 27.50, Peak output power			
Test procedure: 47 CFR, Section 2.1046; TIA/EIA-603-E, Section 2.2.1			
Test mode: Compliance		Verdict: PASS	
Date(s): 06-Aug-23			
Temperature: 21 °C	Relative Humidity: 54 %	Air Pressure: 1012 hPa	Power: 110 VAC, 60 Hz
Remarks:			

Table 7.2.8 Post - transition frequency channels assignment

Channel	Channel BW, MHz	Peak power density limit, dBm/100kHz	
10 MHz QPSK			
2501.0 MHz BRS1+EBS A1	11.5	EIRP+10log(0.1/11.5)	48.75
2593.0 MHz EBS C4+D4	12.0	EIRP+10log(0.1/12.0)	48.69
2685.0 MHz EBS G2+G3	11.0	EIRP+10log(0.1/11.0)	48.14
10 MHz 64 QAM			
2501.0 MHz BRS1+EBS A1	11.5	EIRP+10log(0.1/11.5)	48.75
2593.0 MHz EBS C4+D4	12.0	EIRP+10log(0.1/12.0)	48.69
2685.0 MHz EBS G2+G3	11.0	EIRP+10log(0.1/11.0)	48.14

Table 7.2.9 Post - transition frequency channels assignment

Channel	Channel BW, MHz	Peak power density limit, dBm/100kHz	
20 MHz QPSK			
2506.0 MHz BRS1+EBS A1+A2+A3	22.5	EIRP+10log(0.1/22.5)	46.23
2593.0 MHz EBS B4+C4+D4+ G4	24.0	EIRP+10log(0.1/21.0)	45.68
2680.0 MHz EBS H3+G1+G2+G3	22.0	EIRP+10log(0.1/22.0)	46.415
20 MHz 64 QAM			
2506.0 MHz BRS1+EBS A1+A2+A3	22.5	EIRP+10log(0.1/22.5)	46.23
2593.0 MHz EBS B4+C4+D4+ G4	24.0	EIRP+10log(0.1/21.0)	45.69
2680.0 MHz EBS H3+G1+G2+G3	22.0	EIRP+10log(0.1/22.0)	46.445



HERMON LABORATORIES

Test specification: Section 27.50, Peak output power			
Test procedure: 47 CFR, Section 2.1046; TIA/EIA-603-E, Section 2.2.1			
Test mode: Compliance		Verdict: PASS	
Date(s): 06-Aug-23			
Temperature: 21 °C	Relative Humidity: 54 %	Air Pressure: 1012 hPa	Power: 110 VAC, 60 Hz
Remarks:			

Plot 7.2.1 Peak output power test results frequency, at low, mid, high frequency

CHANNEL BANDWIDTH:
NUMBER OF ANTENNA:

10 MHz
1

MODULATION: QPSK

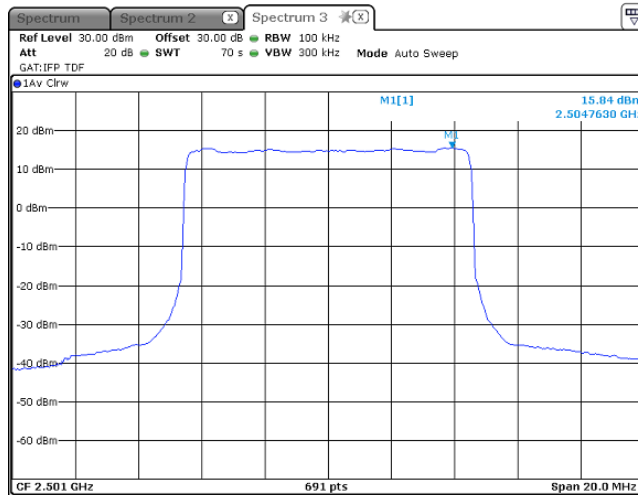

MODULATION: 16 QAM

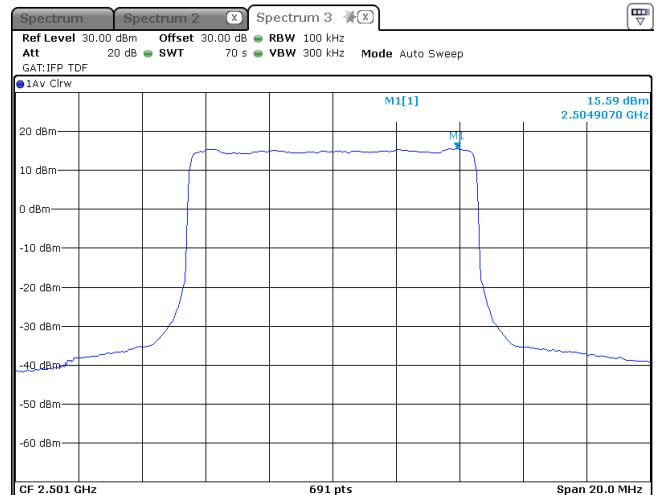

MODULATION: 64 QAM

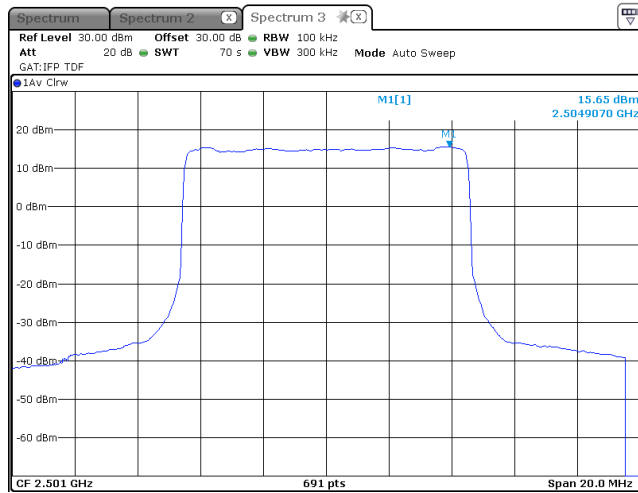

MODULATION: 256 QAM

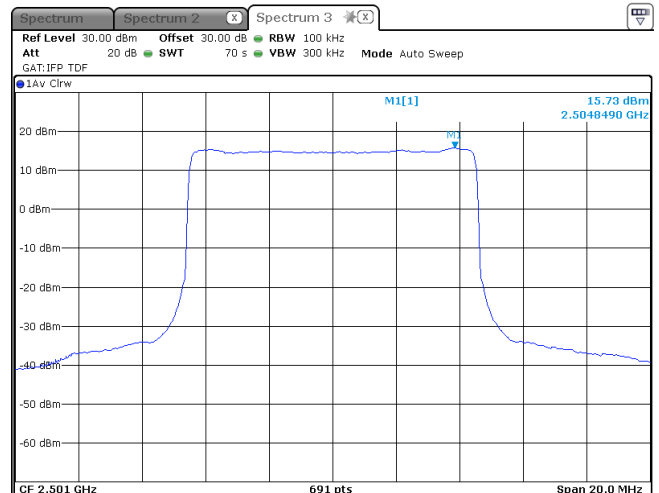



HERMON LABORATORIES

Test specification: Section 27.50, Peak output power			
Test procedure: 47 CFR, Section 2.1046; TIA/EIA-603-E, Section 2.2.1			
Test mode: Compliance		Verdict: PASS	
Date(s): 06-Aug-23			
Temperature: 21 °C	Relative Humidity: 54 %	Air Pressure: 1012 hPa	Power: 110 VAC, 60 Hz
Remarks:			

Plot 7.2.2 Peak output power test results frequency, at low, mid, high frequency

CHANNEL BANDWIDTH:
NUMBER OF ANTENNA:
MODULATION: QPSK

10 MHz
1
MODULATION: 16 QAM

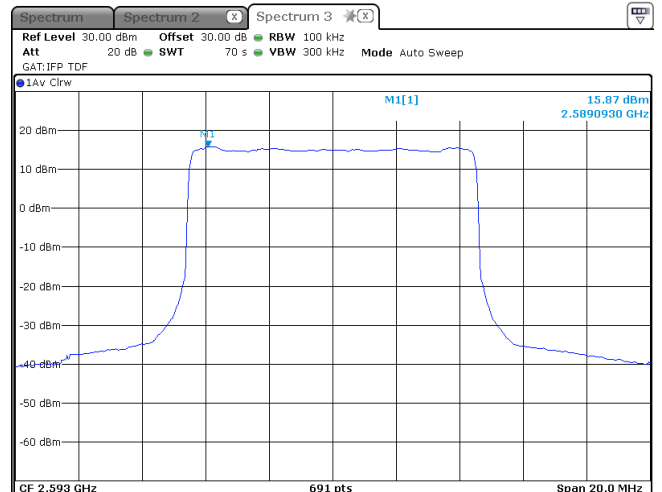
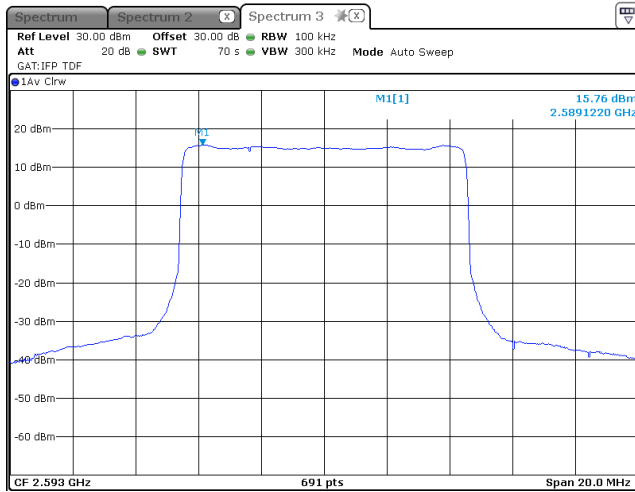

MODULATION: 64 QAM

MODULATION: 256 QAM

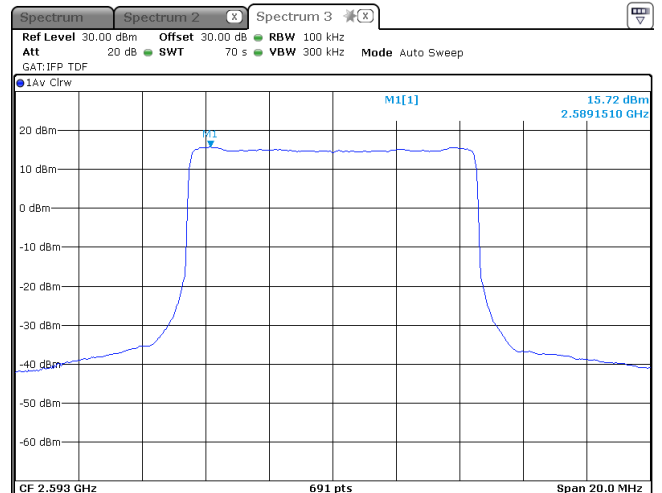
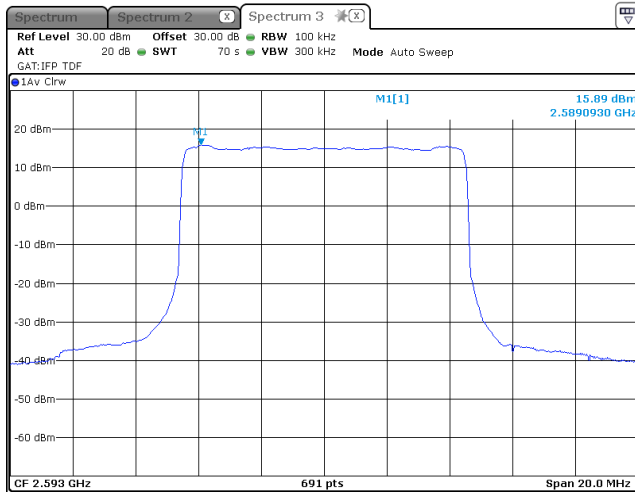



HERMON LABORATORIES

Test specification: Section 27.50, Peak output power			
Test procedure: 47 CFR, Section 2.1046; TIA/EIA-603-E, Section 2.2.1			
Test mode: Compliance		Verdict: PASS	
Date(s): 06-Aug-23			
Temperature: 21 °C	Relative Humidity: 54 %	Air Pressure: 1012 hPa	Power: 110 VAC, 60 Hz
Remarks:			

Plot 7.2.3 Peak output power test results frequency, at low, mid, high frequency

CHANNEL BANDWIDTH:
NUMBER OF ANTENNA:

10 MHz
1

MODULATION: QPSK

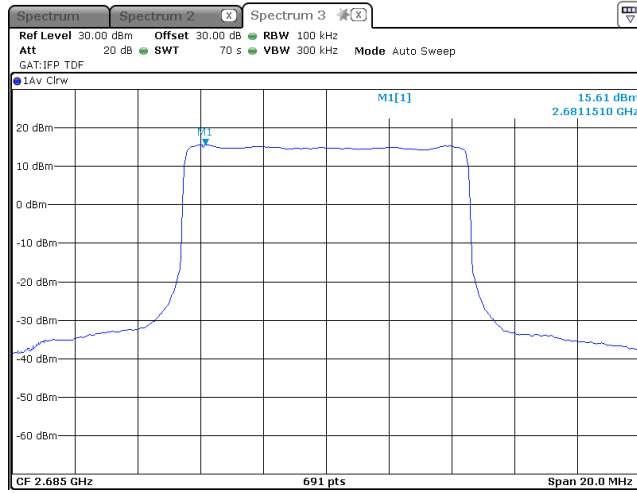

MODULATION: 16 QAM

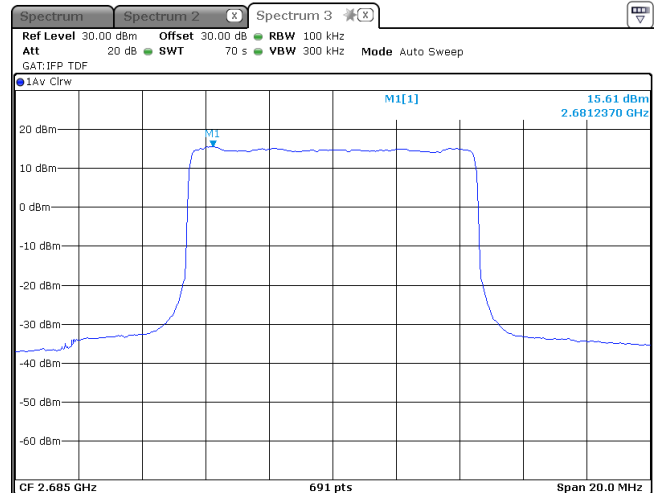

MODULATION: 64 QAM

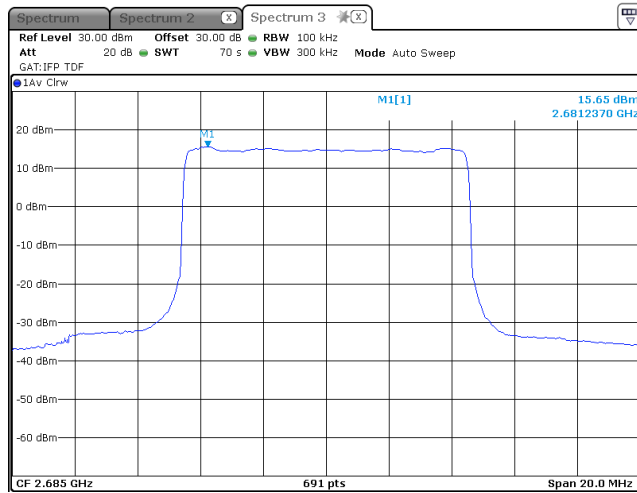

MODULATION: 256 QAM

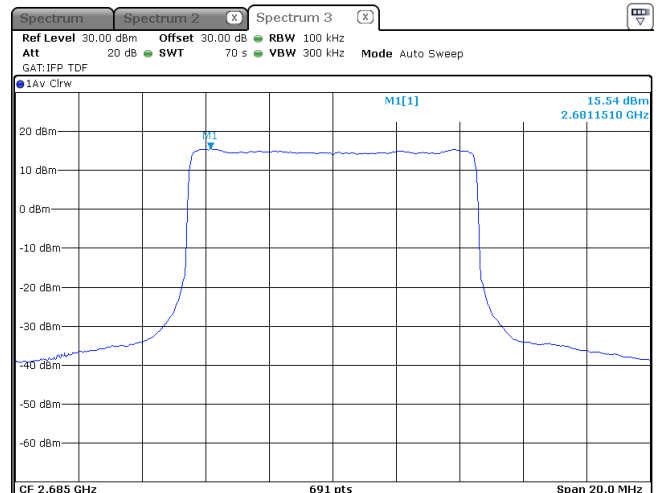



HERMON LABORATORIES

Test specification: Section 27.50, Peak output power			
Test procedure: 47 CFR, Section 2.1046; TIA/EIA-603-E, Section 2.2.1			
Test mode: Compliance		Verdict: PASS	
Date(s): 06-Aug-23			
Temperature: 21 °C	Relative Humidity: 54 %	Air Pressure: 1012 hPa	Power: 110 VAC, 60 Hz
Remarks:			

Plot 7.2.4 Peak output power test results frequency, at low, mid, high frequency

CHANNEL BANDWIDTH:
NUMBER OF ANTENNA:

10 MHz
2

MODULATION: QPSK

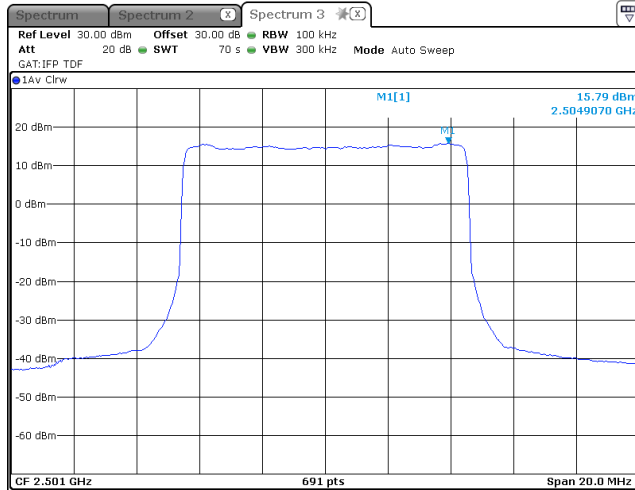

MODULATION: 16 QAM

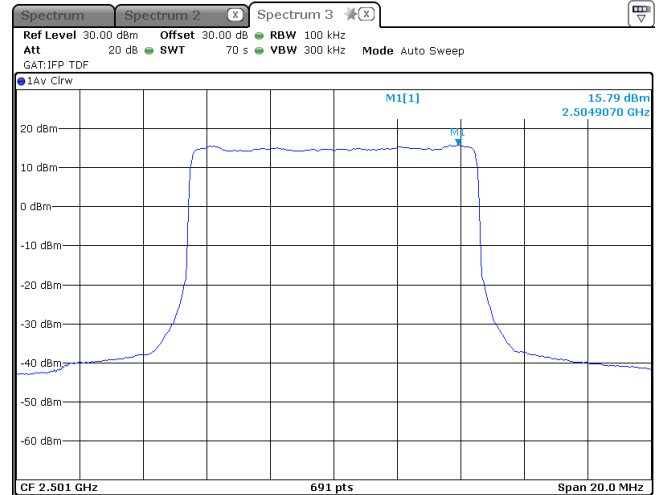

MODULATION: 64 QAM

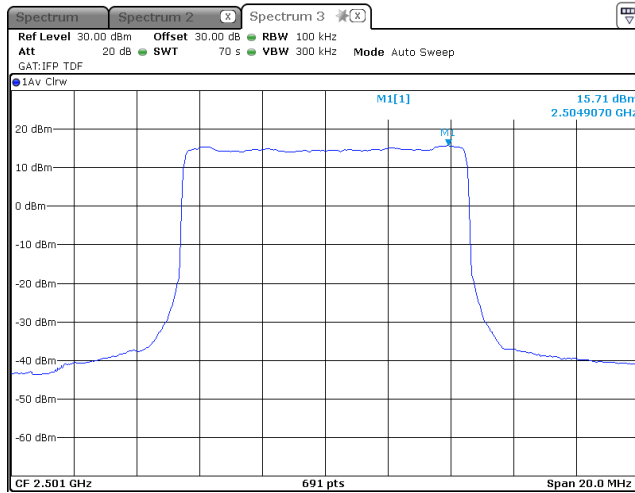

MODULATION: 256 QAM

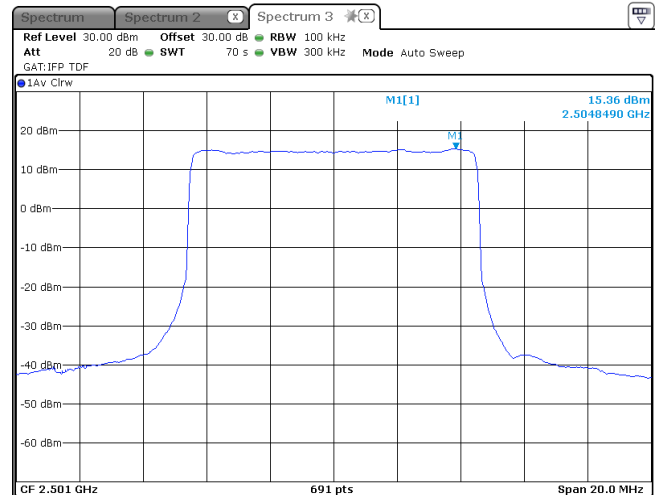



HERMON LABORATORIES

Test specification: Section 27.50, Peak output power			
Test procedure: 47 CFR, Section 2.1046; TIA/EIA-603-E, Section 2.2.1			
Test mode: Compliance		Verdict: PASS	
Date(s): 06-Aug-23			
Temperature: 21 °C	Relative Humidity: 54 %	Air Pressure: 1012 hPa	Power: 110 VAC, 60 Hz
Remarks:			

Plot 7.2.5 Peak output power test results frequency, at low, mid, high frequency

CHANNEL BANDWIDTH:
NUMBER OF ANTENNA:

10 MHz
2

MODULATION: QPSK

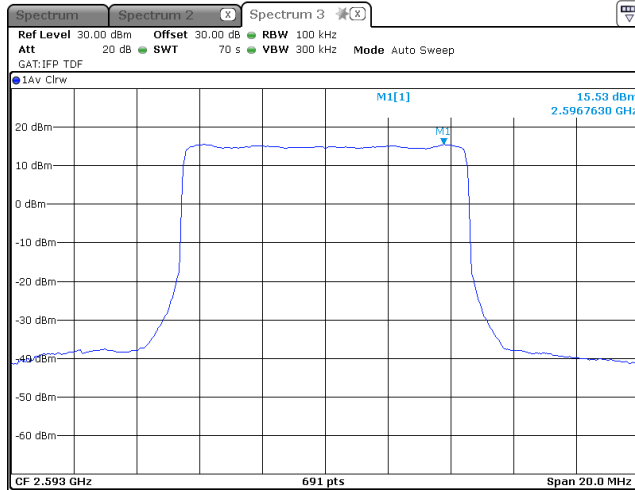

MODULATION: 16 QAM

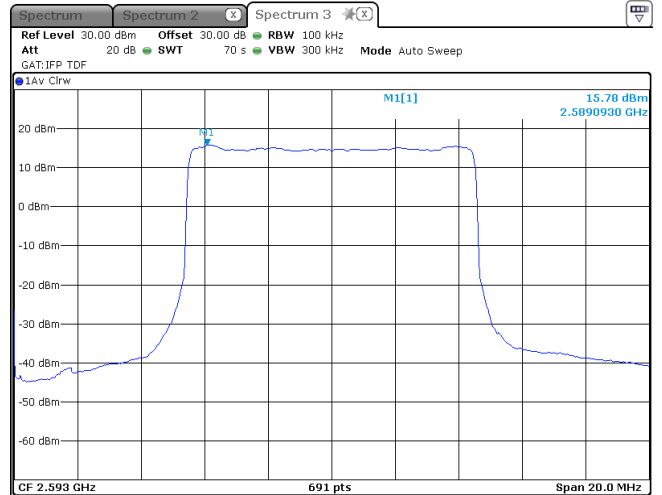

MODULATION: 64 QAM

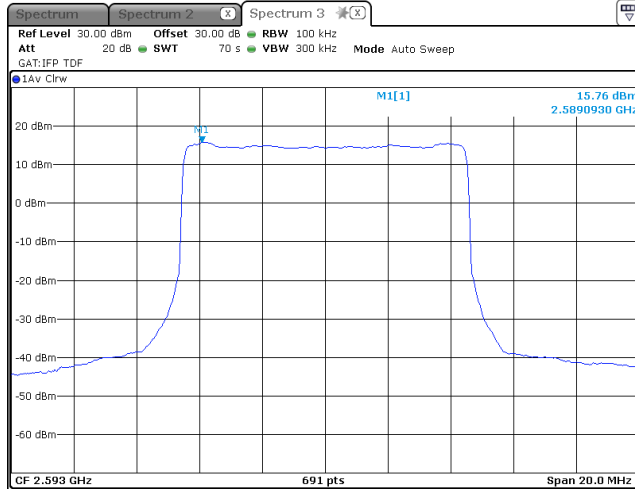

MODULATION: 256 QAM

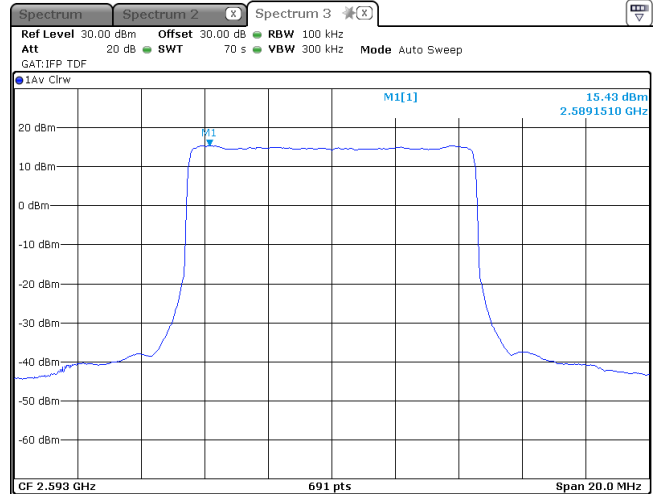



HERMON LABORATORIES

Test specification: Section 27.50, Peak output power			
Test procedure: 47 CFR, Section 2.1046; TIA/EIA-603-E, Section 2.2.1			
Test mode: Compliance		Verdict: PASS	
Date(s): 06-Aug-23			
Temperature: 21 °C	Relative Humidity: 54 %	Air Pressure: 1012 hPa	Power: 110 VAC, 60 Hz
Remarks:			

Plot 7.2.6 Peak output power test results frequency, at low, mid, high frequency

CHANNEL BANDWIDTH:
NUMBER OF ANTENNA:

10 MHz
2

MODULATION: QPSK

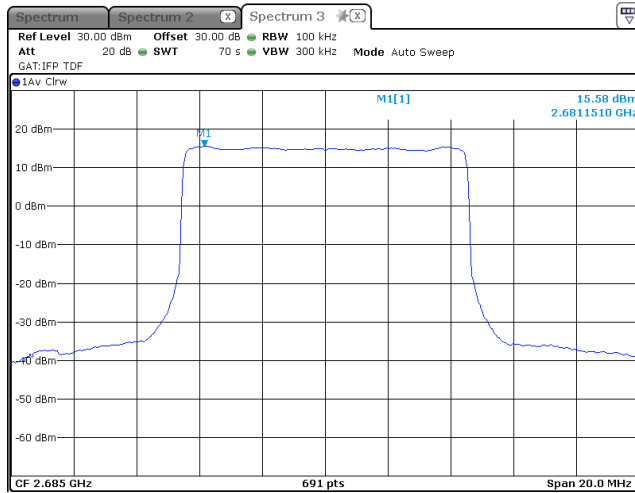

MODULATION: 16 QAM

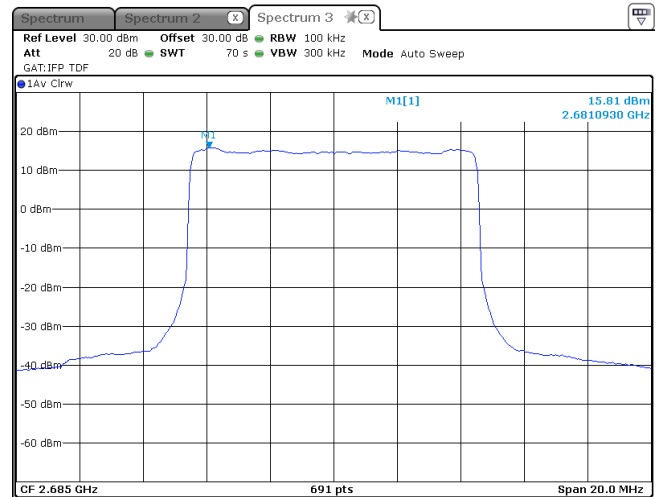

MODULATION: 64 QAM

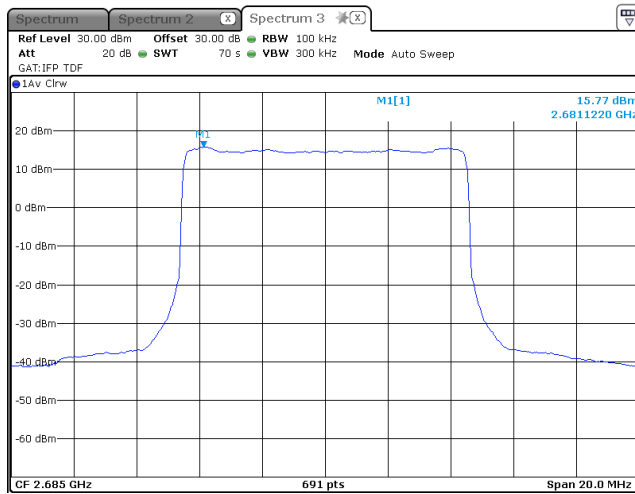

MODULATION: 256 QAM

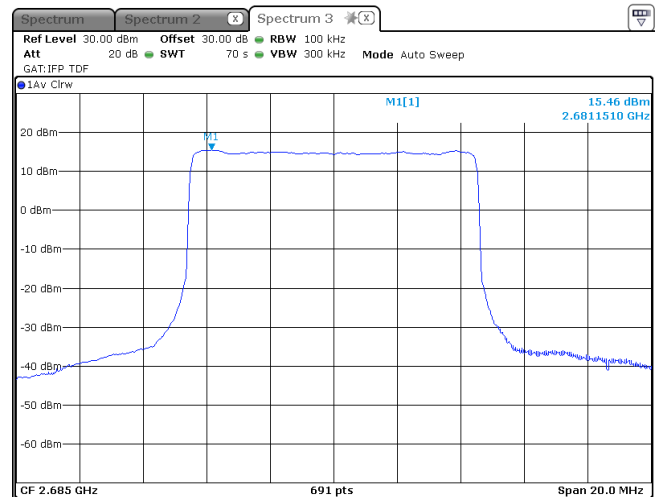



HERMON LABORATORIES

Test specification: Section 27.50, Peak output power			
Test procedure: 47 CFR, Section 2.1046; TIA/EIA-603-E, Section 2.2.1			
Test mode: Compliance		Verdict: PASS	
Date(s): 06-Aug-23			
Temperature: 21 °C	Relative Humidity: 54 %	Air Pressure: 1012 hPa	Power: 110 VAC, 60 Hz
Remarks:			

Plot 7.2.7 Peak output power test results frequency, at low, mid, high frequency

CHANNEL BANDWIDTH:
NUMBER OF ANTENNA:

10 MHz
3

MODULATION: QPSK

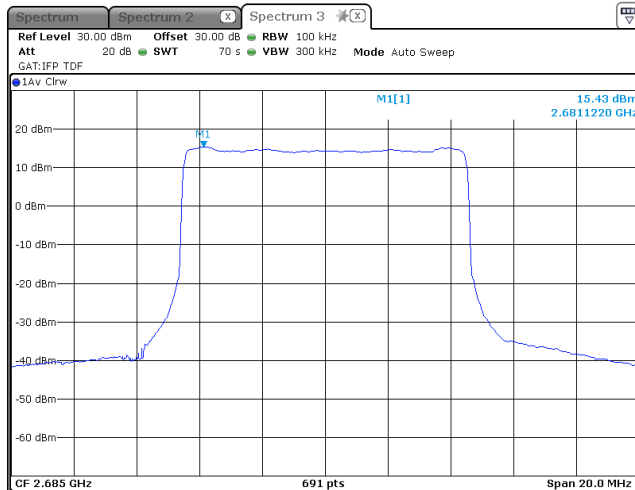

MODULATION: 16 QAM

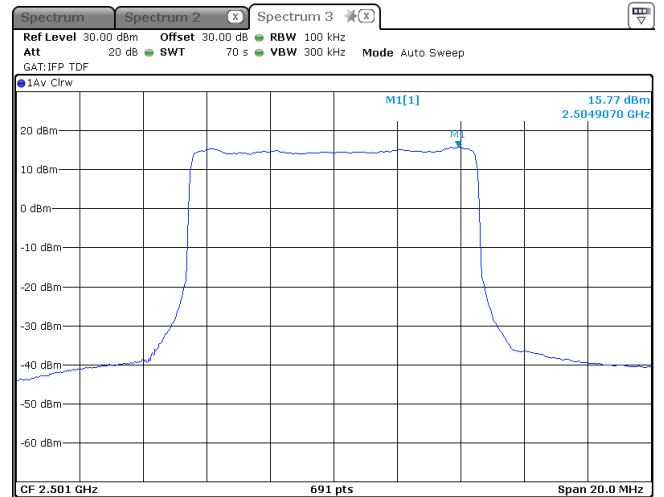

MODULATION: 64 QAM

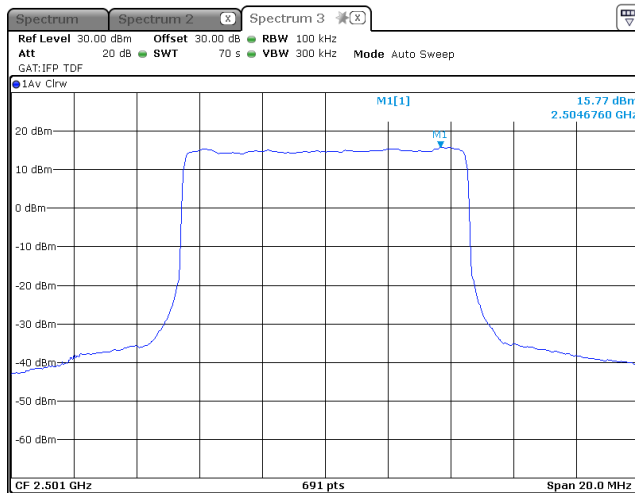

MODULATION: 256 QAM

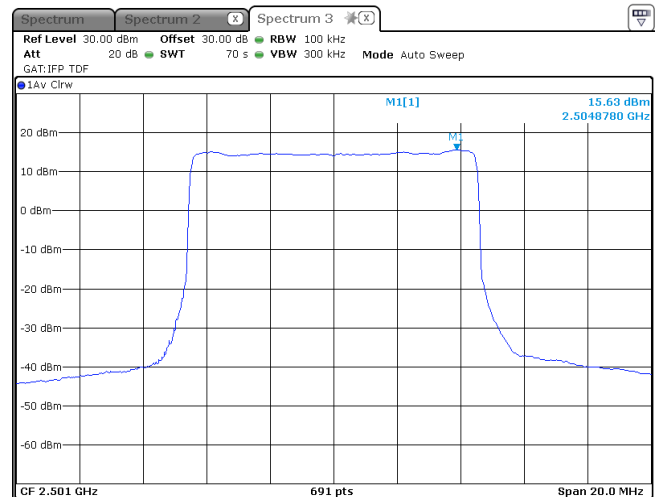



HERMON LABORATORIES

Test specification: Section 27.50, Peak output power			
Test procedure: 47 CFR, Section 2.1046; TIA/EIA-603-E, Section 2.2.1			
Test mode: Compliance		Verdict: PASS	
Date(s): 06-Aug-23			
Temperature: 21 °C	Relative Humidity: 54 %	Air Pressure: 1012 hPa	Power: 110 VAC, 60 Hz
Remarks:			

Plot 7.2.8 Peak output power test results frequency, at low, mid, high frequency

CHANNEL BANDWIDTH:
NUMBER OF ANTENNA:

10 MHz
3

MODULATION: QPSK

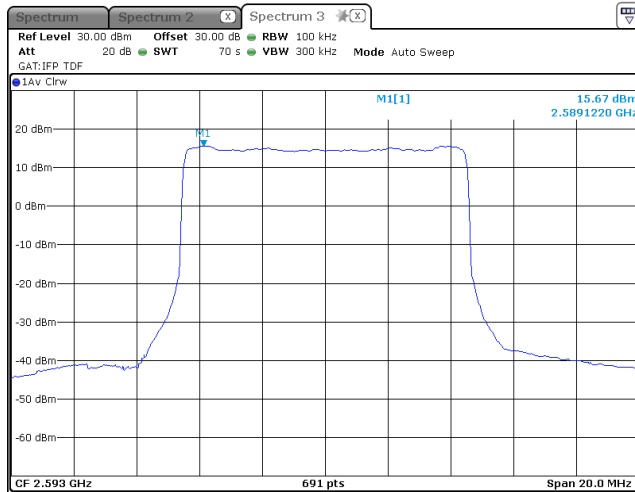

MODULATION: 16 QAM

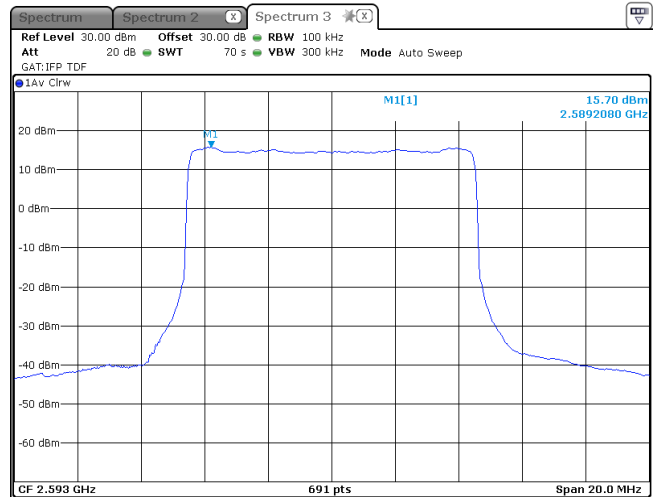

MODULATION: 64 QAM

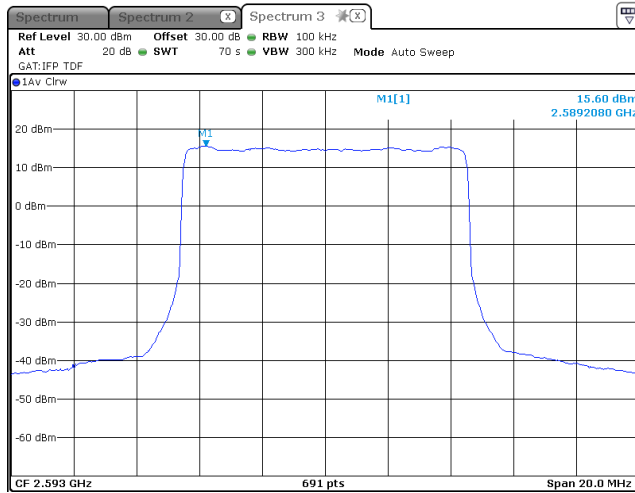

MODULATION: 256 QAM

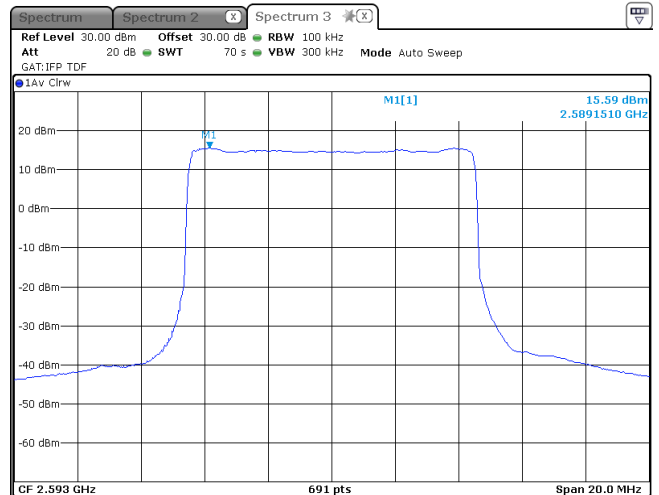



HERMON LABORATORIES

Test specification: Section 27.50, Peak output power			
Test procedure: 47 CFR, Section 2.1046; TIA/EIA-603-E, Section 2.2.1			
Test mode: Compliance		Verdict: PASS	
Date(s): 06-Aug-23			
Temperature: 21 °C	Relative Humidity: 54 %	Air Pressure: 1012 hPa	Power: 110 VAC, 60 Hz
Remarks:			

Plot 7.2.9 Peak output power test results frequency, at low, mid, high frequency

CHANNEL BANDWIDTH:
NUMBER OF ANTENNA:

10 MHz
3

MODULATION: QPSK

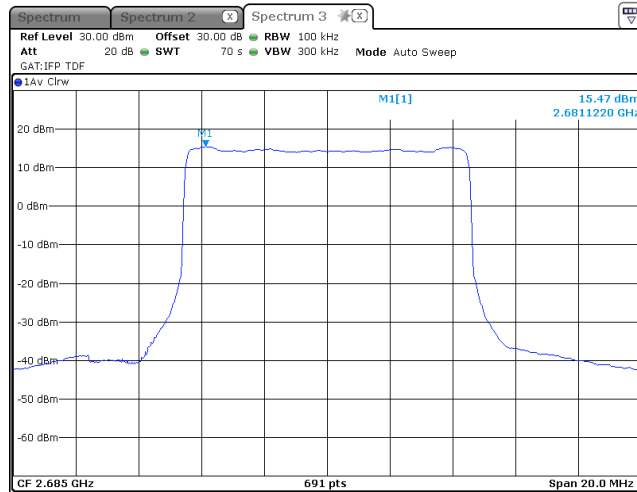

MODULATION: 16 QAM

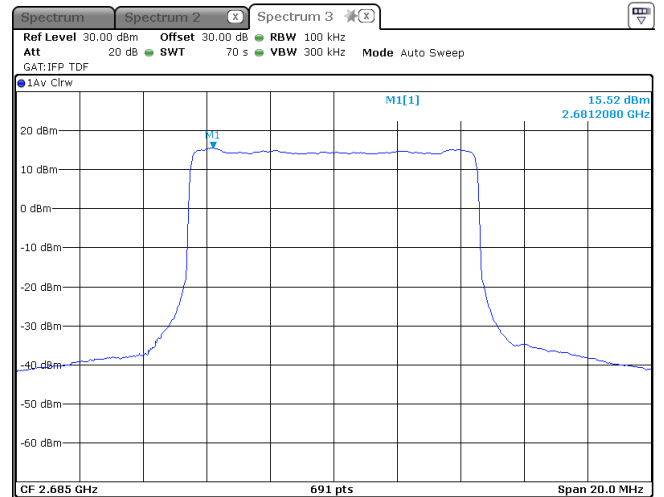

MODULATION: 64 QAM

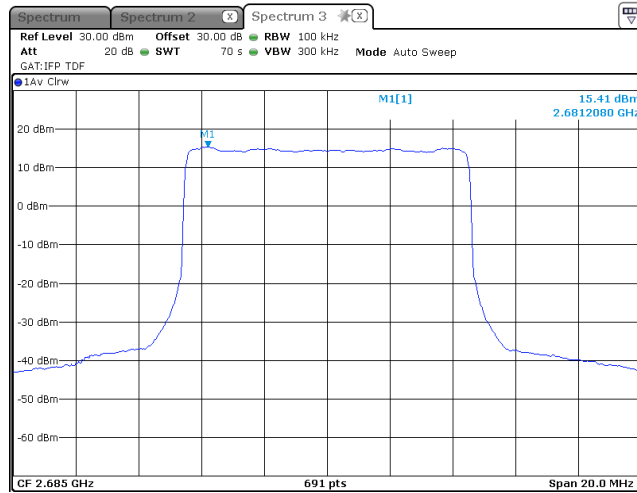

MODULATION: 256 QAM

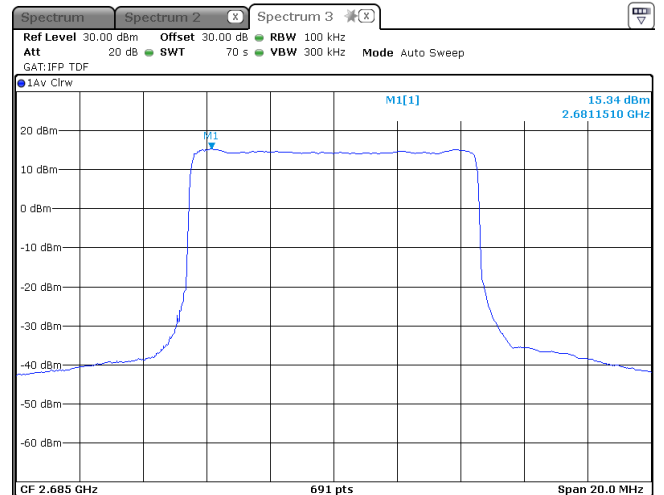



HERMON LABORATORIES

Test specification: Section 27.50, Peak output power			
Test procedure: 47 CFR, Section 2.1046; TIA/EIA-603-E, Section 2.2.1			
Test mode: Compliance		Verdict: PASS	
Date(s): 06-Aug-23			
Temperature: 21 °C	Relative Humidity: 54 %	Air Pressure: 1012 hPa	Power: 110 VAC, 60 Hz
Remarks:			

Plot 7.2.10 Peak output power test results frequency, at low, mid, high frequency

CHANNEL BANDWIDTH:
NUMBER OF ANTENNA:

10 MHz
4

MODULATION: QPSK

MODULATION: 16 QAM

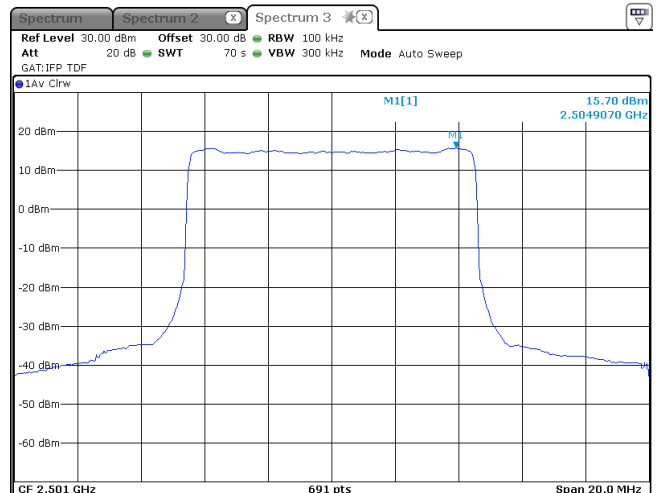
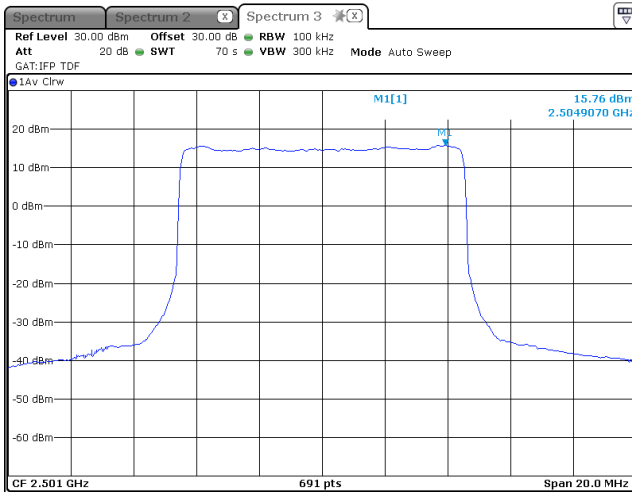

MODULATION: 64 QAM

MODULATION: 256 QAM

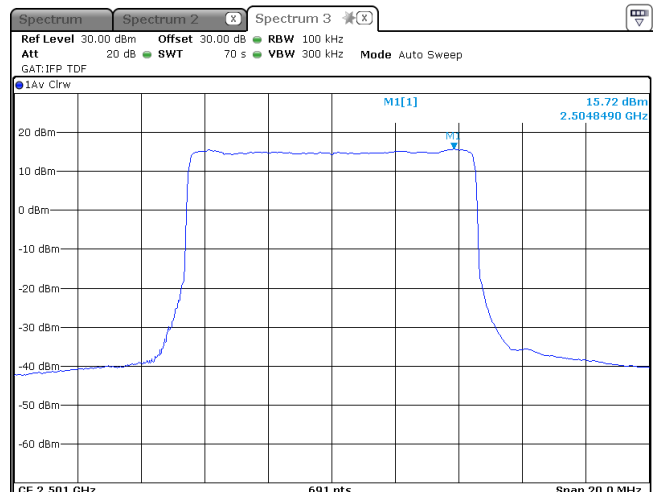
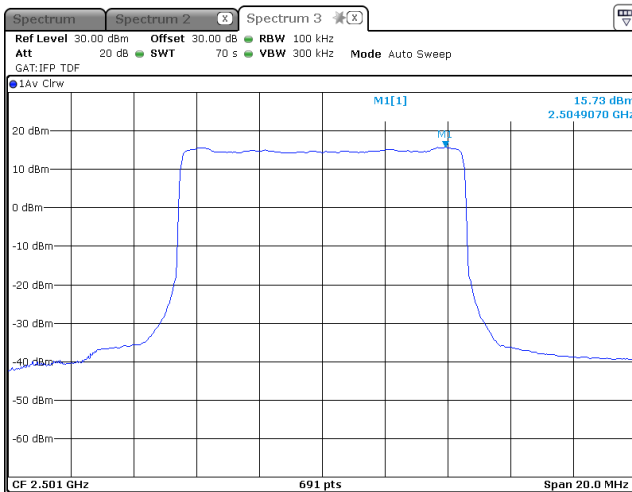



HERMON LABORATORIES

Test specification: Section 27.50, Peak output power			
Test procedure: 47 CFR, Section 2.1046; TIA/EIA-603-E, Section 2.2.1			
Test mode: Compliance		Verdict: PASS	
Date(s): 06-Aug-23			
Temperature: 21 °C	Relative Humidity: 54 %	Air Pressure: 1012 hPa	Power: 110 VAC, 60 Hz
Remarks:			

Plot 7.2.11 Peak output power test results frequency, at low, mid, high frequency

CHANNEL BANDWIDTH:
NUMBER OF ANTENNA:

10 MHz
4

MODULATION: QPSK

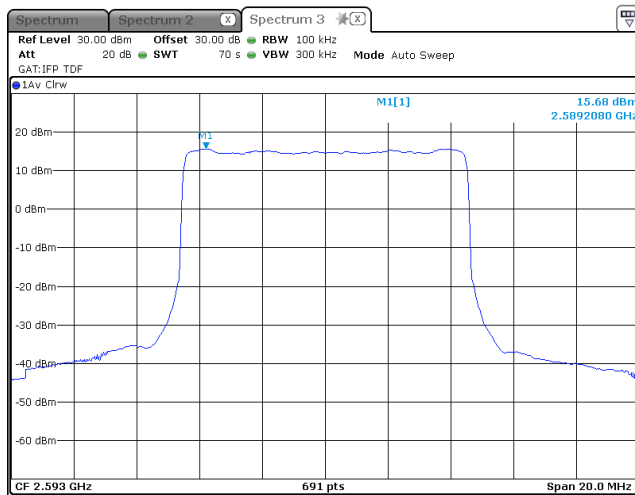

MODULATION: 16 QAM

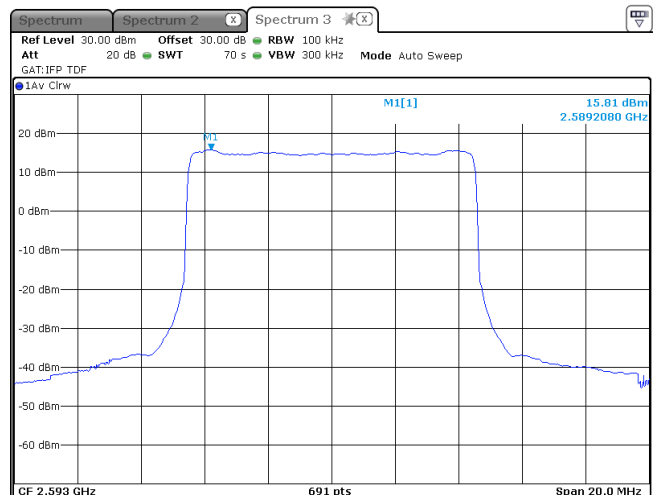

MODULATION: 64 QAM

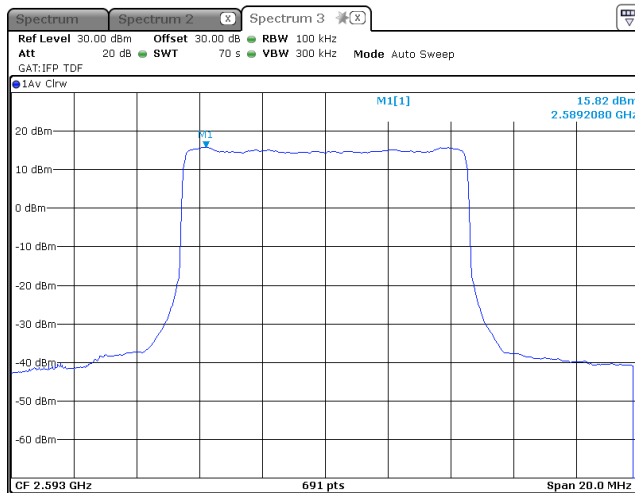

MODULATION: 256 QAM

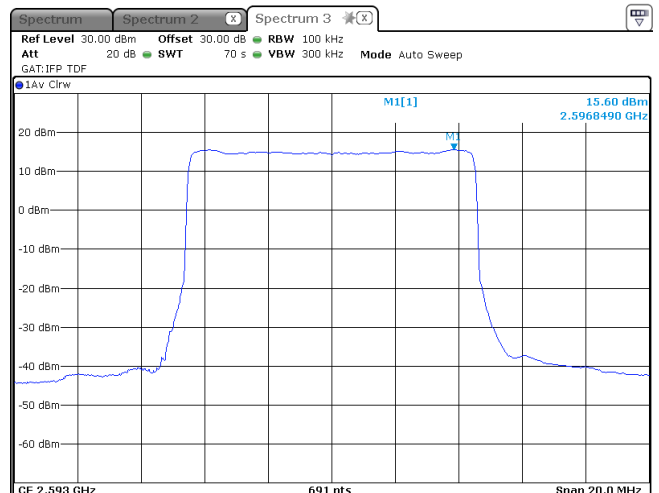



HERMON LABORATORIES

Test specification: Section 27.50, Peak output power			
Test procedure: 47 CFR, Section 2.1046; TIA/EIA-603-E, Section 2.2.1			
Test mode: Compliance		Verdict: PASS	
Date(s): 06-Aug-23			
Temperature: 21 °C	Relative Humidity: 54 %	Air Pressure: 1012 hPa	Power: 110 VAC, 60 Hz
Remarks:			

Plot 7.2.12 Peak output power test results frequency, at low, mid, high frequency

CHANNEL BANDWIDTH:
NUMBER OF ANTENNA:

10 MHz
4

MODULATION: QPSK

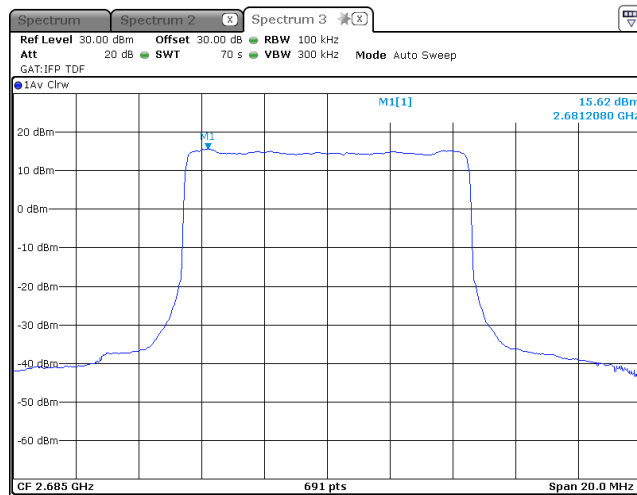

MODULATION: 16 QAM

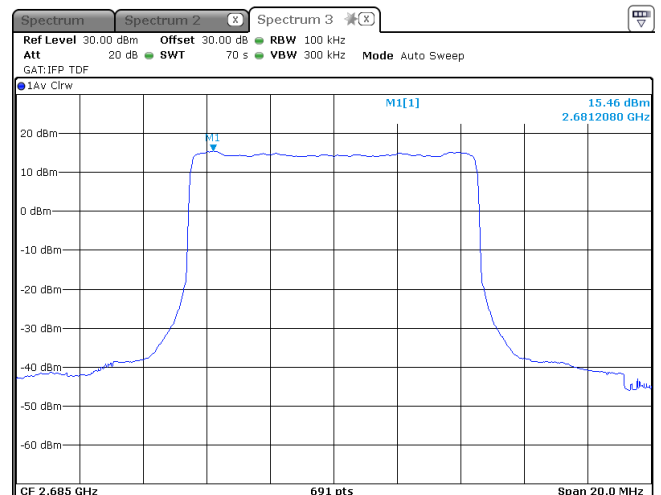

MODULATION: 64 QAM

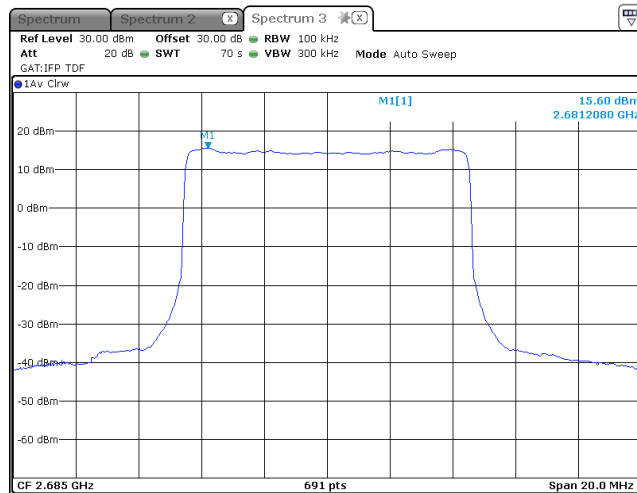

MODULATION: 256 QAM

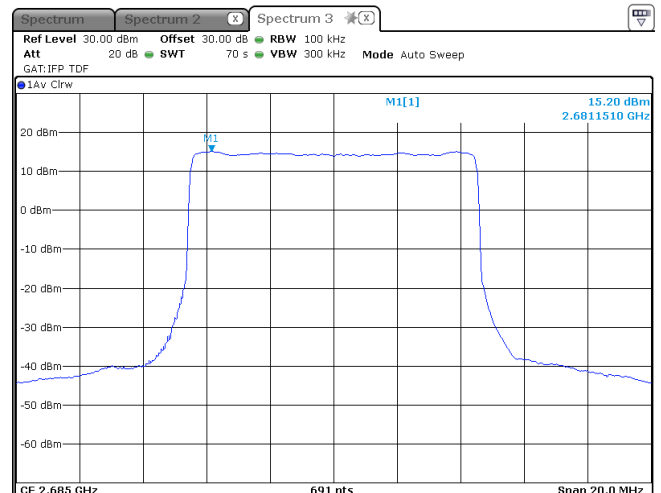



HERMON LABORATORIES

Test specification: Section 27.50, Peak output power			
Test procedure: 47 CFR, Section 2.1046; TIA/EIA-603-E, Section 2.2.1			
Test mode: Compliance		Verdict: PASS	
Date(s): 06-Aug-23			
Temperature: 21 °C	Relative Humidity: 54 %	Air Pressure: 1012 hPa	Power: 110 VAC, 60 Hz
Remarks:			

Plot 7.2.13 Peak output power test results frequency, at low, mid, high frequency

CHANNEL BANDWIDTH:
NUMBER OF ANTENNA:

20 MHz
1

MODULATION: QPSK

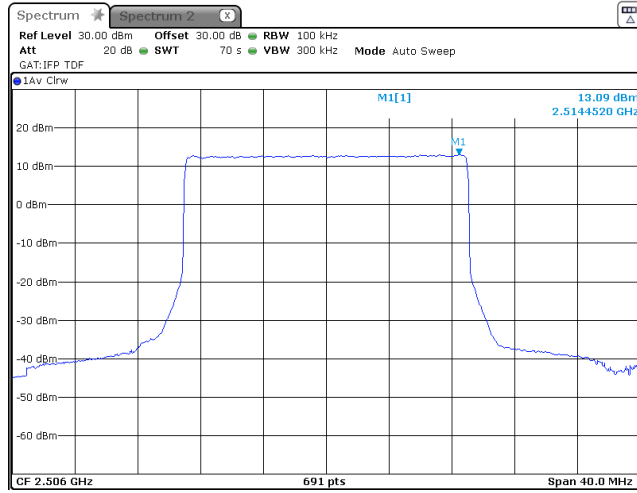

MODULATION: 16 QAM

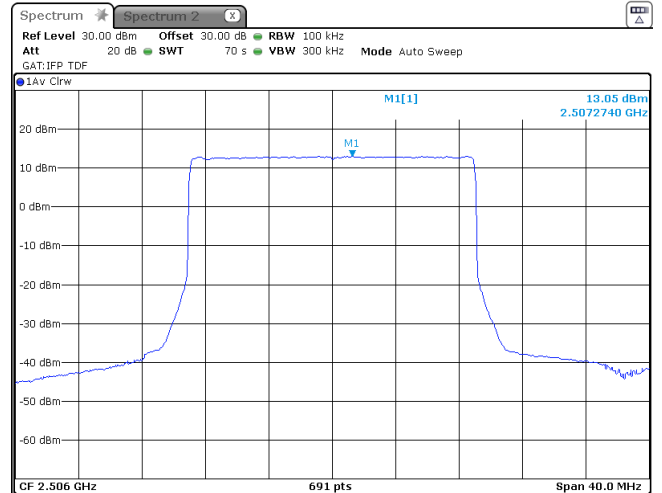

MODULATION: 64 QAM

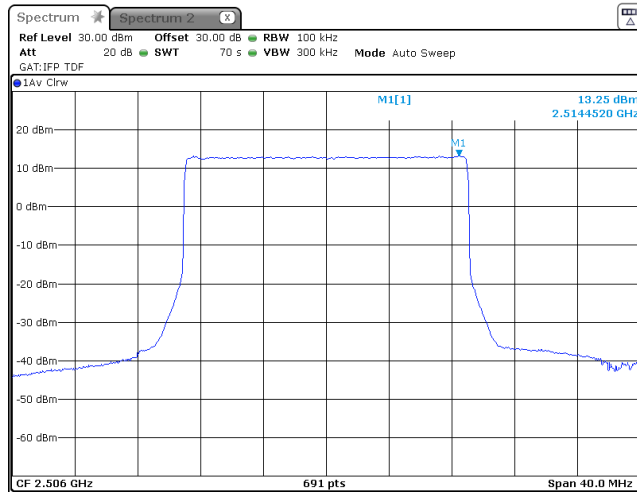

MODULATION: 256 QAM

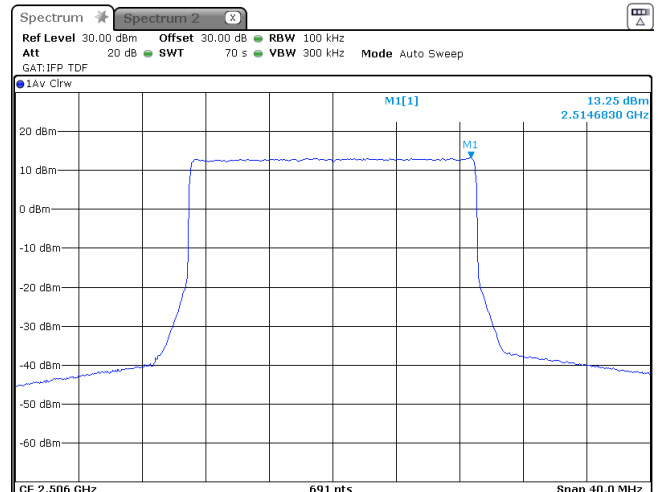



HERMON LABORATORIES

Test specification: Section 27.50, Peak output power			
Test procedure: 47 CFR, Section 2.1046; TIA/EIA-603-E, Section 2.2.1			
Test mode: Compliance		Verdict: PASS	
Date(s): 06-Aug-23			
Temperature: 21 °C	Relative Humidity: 54 %	Air Pressure: 1012 hPa	Power: 110 VAC, 60 Hz
Remarks:			

Plot 7.2.14 Peak output power test results frequency, at low, mid, high frequency

CHANNEL BANDWIDTH:
NUMBER OF ANTENNA:

20 MHz
1

MODULATION: QPSK

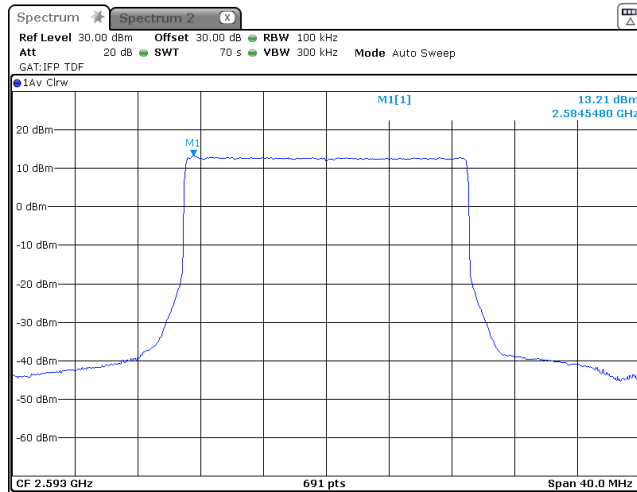

MODULATION: 16 QAM

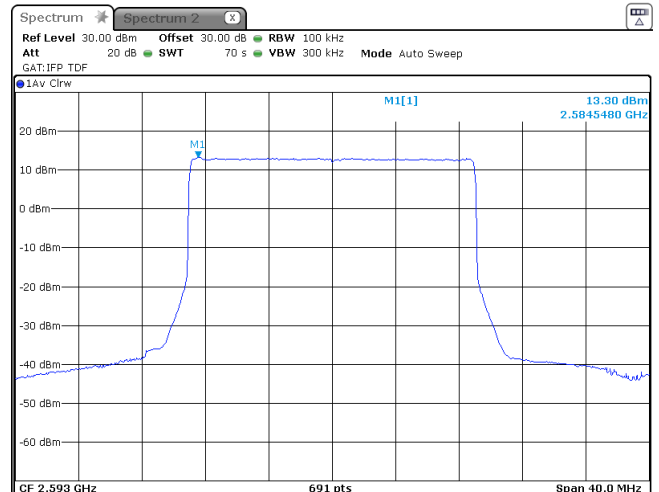

MODULATION: 64 QAM

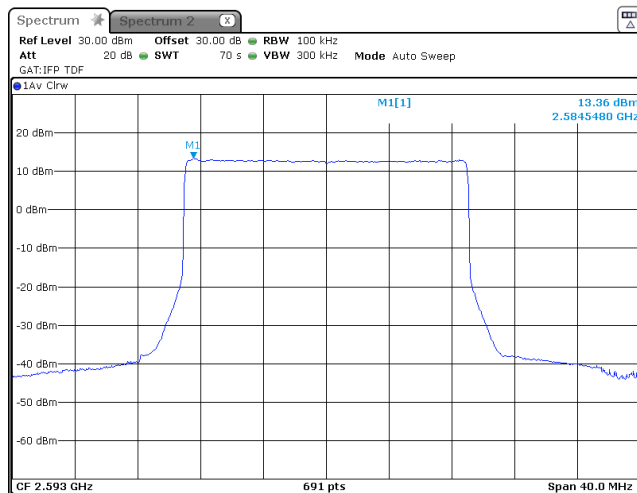

MODULATION: 256 QAM

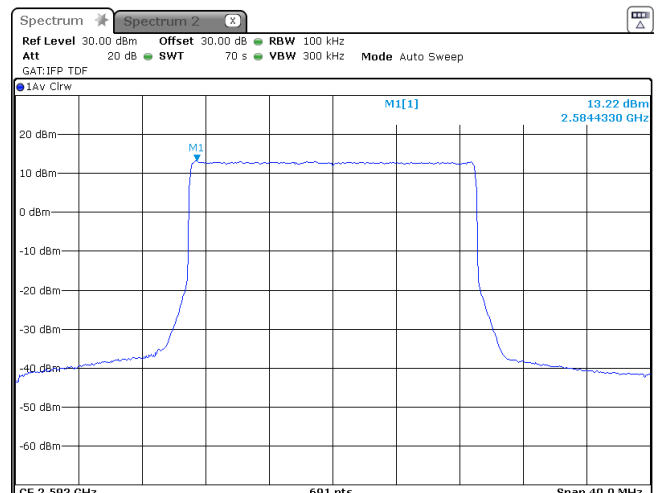



HERMON LABORATORIES

Test specification: Section 27.50, Peak output power			
Test procedure: 47 CFR, Section 2.1046; TIA/EIA-603-E, Section 2.2.1			
Test mode: Compliance		Verdict: PASS	
Date(s): 06-Aug-23			
Temperature: 21 °C	Relative Humidity: 54 %	Air Pressure: 1012 hPa	Power: 110 VAC, 60 Hz
Remarks:			

Plot 7.2.15 Peak output power test results frequency, at low, mid, high frequency

CHANNEL BANDWIDTH:
NUMBER OF ANTENNA:

20 MHz
1

MODULATION: QPSK

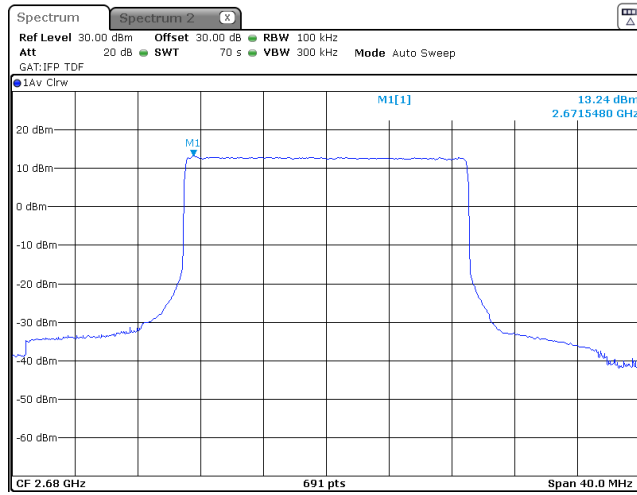

MODULATION: 16 QAM

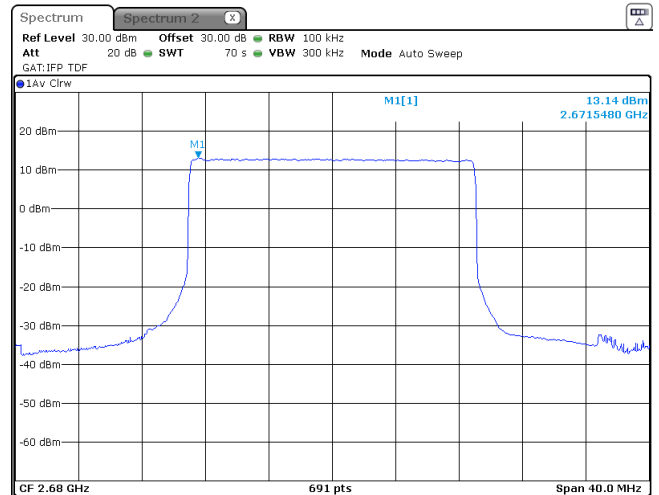

MODULATION: 64 QAM

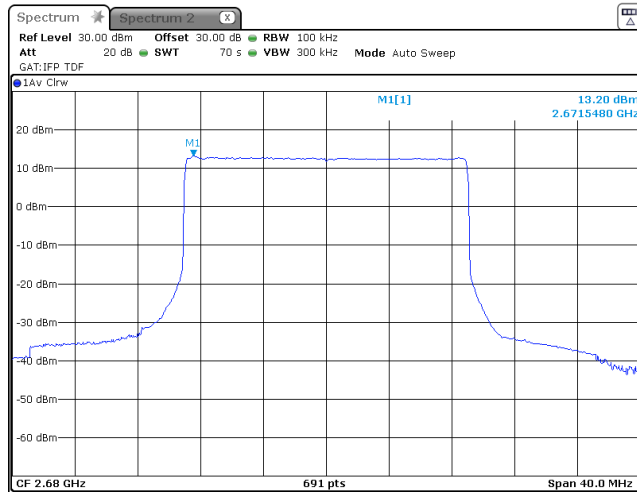

MODULATION: 256 QAM

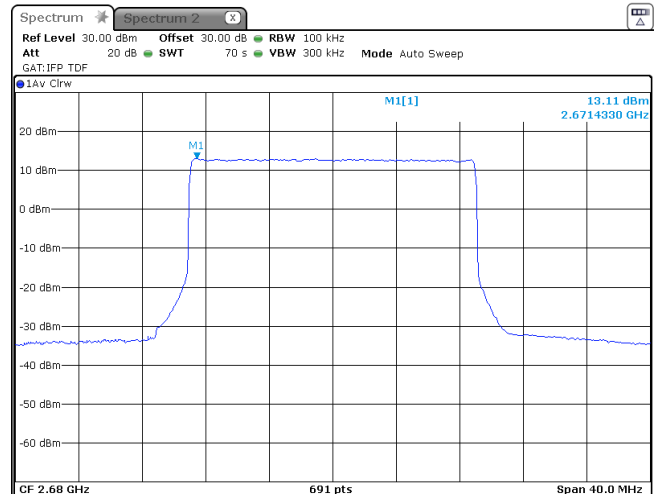



HERMON LABORATORIES

Test specification: Section 27.50, Peak output power			
Test procedure: 47 CFR, Section 2.1046; TIA/EIA-603-E, Section 2.2.1			
Test mode: Compliance		Verdict: PASS	
Date(s): 06-Aug-23			
Temperature: 21 °C	Relative Humidity: 54 %	Air Pressure: 1012 hPa	Power: 110 VAC, 60 Hz
Remarks:			

Plot 7.2.16 Peak output power test results frequency, at low, mid, high frequency

CHANNEL BANDWIDTH:
NUMBER OF ANTENNA:

20 MHz
2

MODULATION: QPSK

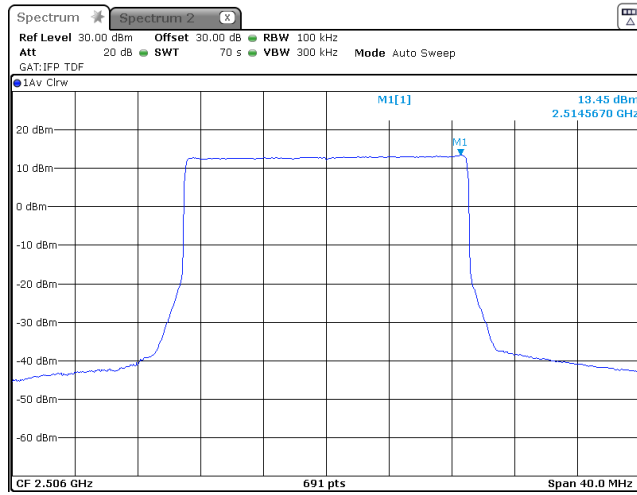

MODULATION: 16 QAM

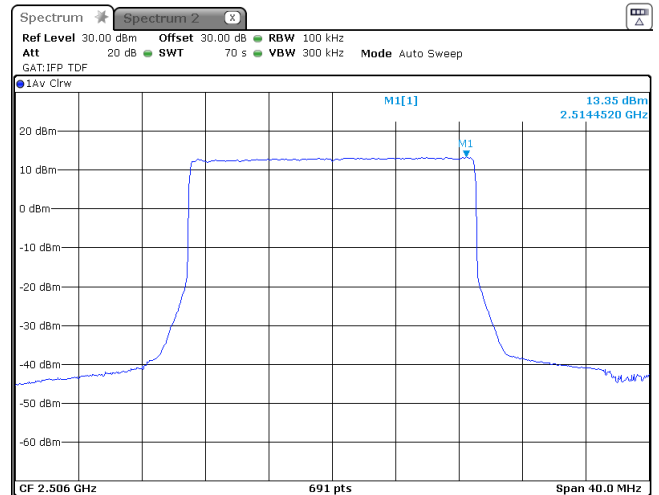

MODULATION: 64 QAM

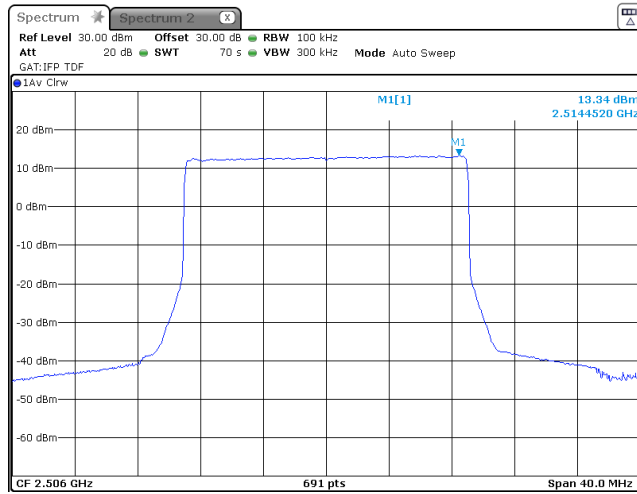

MODULATION: 256 QAM

