

Symptom	Possible Cause	Remedy
between any two modules).	<ul style="list-style-type: none">• Rectifier(s) are not properly adjusted.	<ul style="list-style-type: none">• Re-adjust the voltage of the problematic rectifier(s).
Battery backup time is too low	<ul style="list-style-type: none">• Battery is too small for the application.• Charging voltage is too low• Weak battery	<ul style="list-style-type: none">• Increase battery capacity• Raise the system output voltage using the "VOLT ADJ."• Replace the battery and check ambient temperature according to manufacturer's instructions



Part II

Installing WipLL Customer Premises Equipment

Part II describes the procedures for installing the WipLL equipment located at the subscriber's premises.

Part II includes the following chapters:

- Chapter 8, "Installing the SPR"
- Chapter 9, "Installing the SDA"
- Chapter 10, "Installing the IDR"

This page is intentionally left blank.



Installing the SPR

This chapter describes the installation of the WipLL **Subscriber Premises Radio (SPR)** at the subscriber's premises.

This chapter includes the following chapters:

- Overview
- Physical Dimensions and Basic Design
- Cable Guidelines
- Mounting the SPR
 - Minimum Distance between SPRs
 - Wall Mounting
 - Pole Mounting
- Connecting an External Third-Party Antenna (Optional)
- Connecting to the SDA
- Connecting to a PC for Serial Configuration
- Connecting the RSS LED Adapter
- Connecting Power

8.1. Overview

The SPR receives and transmits data from and to the base station. The SPR connects to the subscriber's network through the SDA. The SDA is an Ethernet hub/LAN switch (depending on SDA model) that provides the SPR with DC power, lightning protection, and Ethernet (10Base-T and/or 100Base-T)connectivity to the subscriber's PCs/network (up to four PCs depending on SDA model). The SPR connects to the SDA by a CAT-5 cable.

The SPR is typically mounted on the subscriber's roof or external wall; the SDA is installed inside the subscriber's premises.

The SPR is available in the following models:

- **SPR with Standard Gain:** includes a built-in antenna 15-dBi antenna gain, covering an area of 23 degrees
- **SPR with High-Gain Antenna:** includes a built-in antenna with an 18-dBi antenna gain, covering 15 degrees.
- **SPR with External Antenna:** includes an N-type connector port for attaching a third-party external antenna.

Figure 8-1 displays a typical setup of the SPR and SDA at the subscriber's premises.



Note: The SDA can also be installed at a base station that has only one BSR. This SDA replaces the need for the BSDU, and provides power and connectivity to the single BSR.

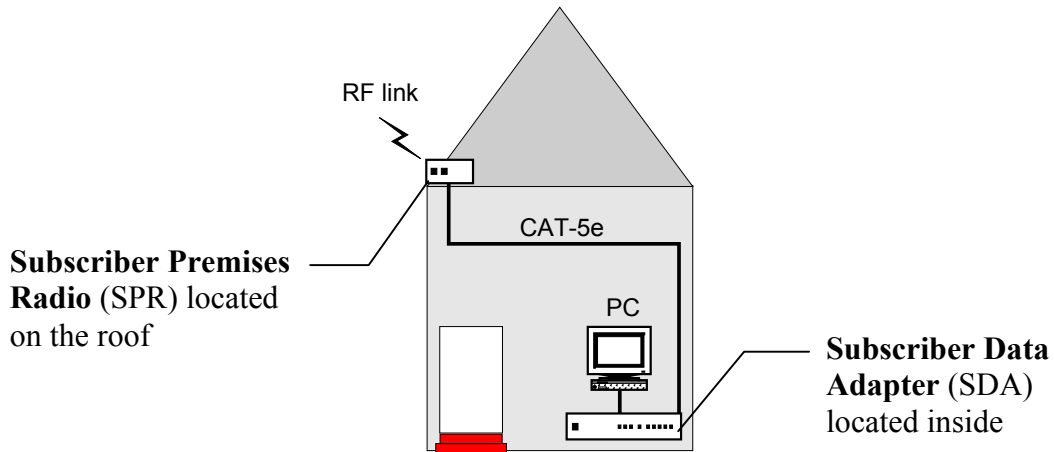

Figure 8-1: Typical SPR and SDA location and connections at subscriber's premises



Warning: As the system emits microwave radiation, a minimum distance of 200 mm must be maintained from the front of the SPR.

To avoid electrical or fire hazard, connect the SPR to the power supply only after mounting the SPR and connecting data cables between the SPA and SDA units.



Note: Usually, the SPR is initialized (i.e., configured with an IP address) at Airspan's factory. However, if the SPR has not been configured, see Section 8.7, "Connecting to a PC for Serial Configuration", before mounting the SPR.



Note: The digital portion of the transceiver has been tested and found to comply with the limits for a Class B digital device, pursuant to part 15 of the FCC rules. These limits are designed to provide reasonable protection against harmful interference in a residential installation. This equipment generates, uses, and can radiate radio frequency energy and, if not installed and used in accordance with the instructions, may cause harmful interference to radio communications. However, there is no guarantee that interference will not occur in a particular installation. If this equipment does cause harmful interference to radio or television reception, which can be determined by turning the equipment on and off, the user is encouraged to try correct the interference by performing one or more of the following measures:

- Reorientate or relocate the receiving antenna
 - Increase separation between the equipment and receiver
 - Connect the equipment to an outlet on a circuit different from that to which the receiver is connected
 - Consult the dealer or an experienced radio/TV technician for help
-

8.2. Physical Dimensions and Basic Design

The SPR is encased in a chassis and provides access to the SPR’s communication port at the front panel. The SPR’s bottom panel provides holes for mounting the SPR to, for example, a pole or wall (see Figure 8-3).



Figure 8-2: SPR (with built-in antenna)

The SPR’s physical dimensions are described in Table 8-1

Table 8-1: SPR physical dimensions

Parameter	SPR model	
	Standard Gain Antenna	High Gain Antenna
Height	311 mm (12.24 inches)	400 mm (15.74 inches)
Width	224 mm (8.82 inches)	317 mm (12.48 inches)
Depth	65.5 mm (2.58 inches)	65.5 mm (2.58 inches)
Weight	2.5 kg	4.7 kg



Notes:

- 1) The SPR’s physical dimensions exclude the mounting kit.
- 2) An SPR model with an N-type receptacle for attaching a third-party external antenna is also available (see Section 8.5, “Connecting a Third-Party External Antenna (Optional)”).

8.3. Cable Guidelines

The following lists cable installation guidelines at the subscriber's premises:

- To prevent tripping, a wiring duct is to be provided at the subscriber's premises to house data cables. Wiring channel type, location, and methods of securing are to be discussed with the subscriber.
- Cables not housed in wiring channel must be dressed in a manner to avoid a trip hazard. Avoid trailing wires across passageways.
- External data cables are to be protected in metal conduit that is to be secured to the building structure in accordance with manufacturers recommendations.
- Outside wiring channels must not be located as to cause a trip hazard (e.g. roof walkways)
- Observe recommended minimum bend radii when installing copper cables. Wherever a cable changes direction, ensure that it does so in a smooth curve with a radius of at least 50 mm in order to prevent damage.
- A maintenance loop is to be left in the cable just before the cable reaches the SPR to prevent strain on the connector.
- Data cables threaded into holes drilled in walls are to be covered by a waterproof sheath to prevent water penetration.
- Silicone sealant should be used to plug any holes on both internal and external wall surfaces once cables are in place.
- All data cables should be labeled with both the source and destination at each end. Un-used cable ends must also be identified with labels to assist with future upgrades.



Warning: Cables with exposed ends (i.e., not yet crimped) should be covered with protective polythene bags during external cable installation processes.



Note: A minimum separation of 200 mm should exist between power and data cables.

8.4. Mounting the SPR

The SPR can be mounted on a wall or pole. The SPR is mounted using the mounting holes located on the SPR's bottom panel (see Figure 8-3), and the mounting bracket (provided). The mounting brackets for wall- and pole-mounting are different from one another.

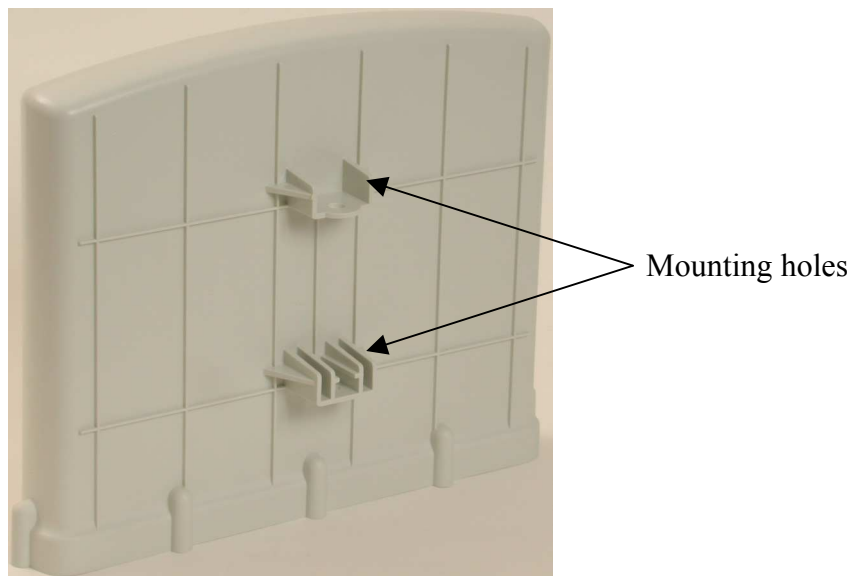

Figure 8-3: SPR bottom panel providing holes for mounting

8.4.1. Minimum Distance between SPRs

A minimum of 3-meter separation is required between mounted SPRs and existing customer radio equipment when not transmitting on the same sector (see Figure 8-4).

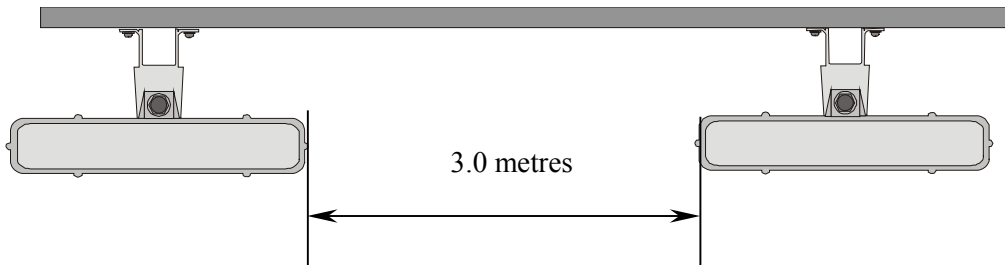

Figure 8-4: SPR separation when not transmitting on the same sector

A 1-meter separation is required between SPRs when on the same sector and transmitting to the same BSR without requiring shielding (see Figure 8-5).

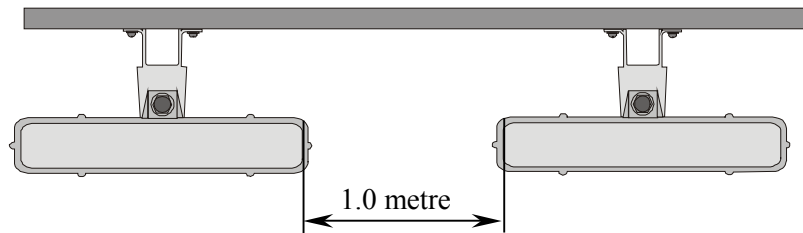

Figure 8-5: SPR separation when transmitting on the same sector to the same BSR

8.4.2. Wall-Mounting

SPR wall mounting is performed in two chronological stages:

- Attaching the mounting bracket to the SPR's mounting holes.
- Attaching the mounting bracket (attached to the SPR) to the wall.

To mount the SPR on a wall:

1. Attach the mounting bracket to the SPR using two stainless steel bolts, as shown in Figure 8-6.

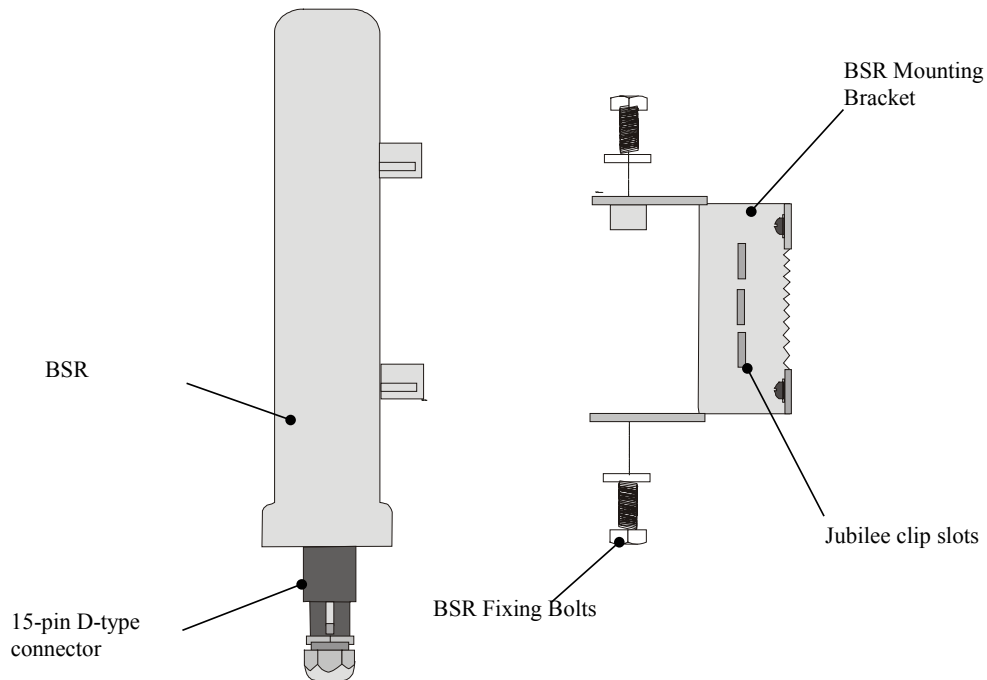

Figure 8-6: Attaching the mounting bracket to the SPR

2. Attach the mounting bracket to the wall using four screws. The fixing dimensions for the mounting bracket is illustrated in Figure 8-7.

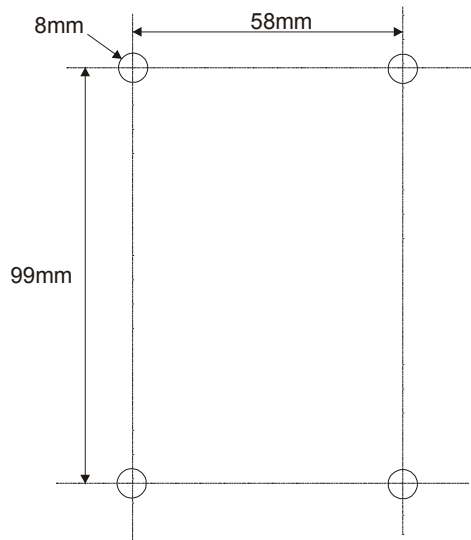

Figure 8-7: SPR mounting bracket dimensions for the four fixing holes



Note: Airspan does not provide screws for attaching the mounting bracket to the wall. The screw size depends on the structure of the building to which the bracket is to be attached. When selecting screw sizes, consideration must be given to the weight of the SPR and load that may be induced in windy conditions.

3. Adjust the horizontal positioning of the SPR, and then fasten tight the two stainless-steel bolts.

Rotation is restricted to the horizontal plane only. The permissible rotation is shown in Figure 8-8.

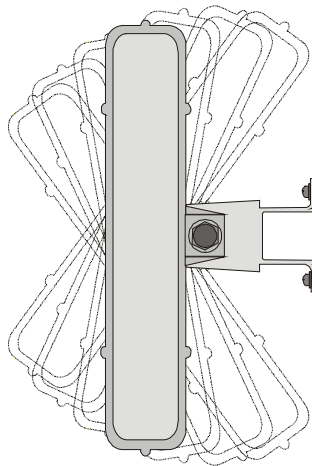

Figure 8-8: Horizontal rotation of the SPR



Note: A thread-locking compound is to be used to prevent the bolts working loose.

8.4.3. Pole-Mounting

The SPR can be mounted on a pole (see Figure 8-9). Pole mounting allows the SPR to be adjusted in the horizontal as well as the vertical plane. The pole-mounting bracket assembly is designed to support the SPR on a round pole of 45 mm in diameter.



Figure 8-9: Mounted SPR

To mount the SPR on a pole:

1. Attach the mounting bracket to the SPR using two stainless steel bolts.

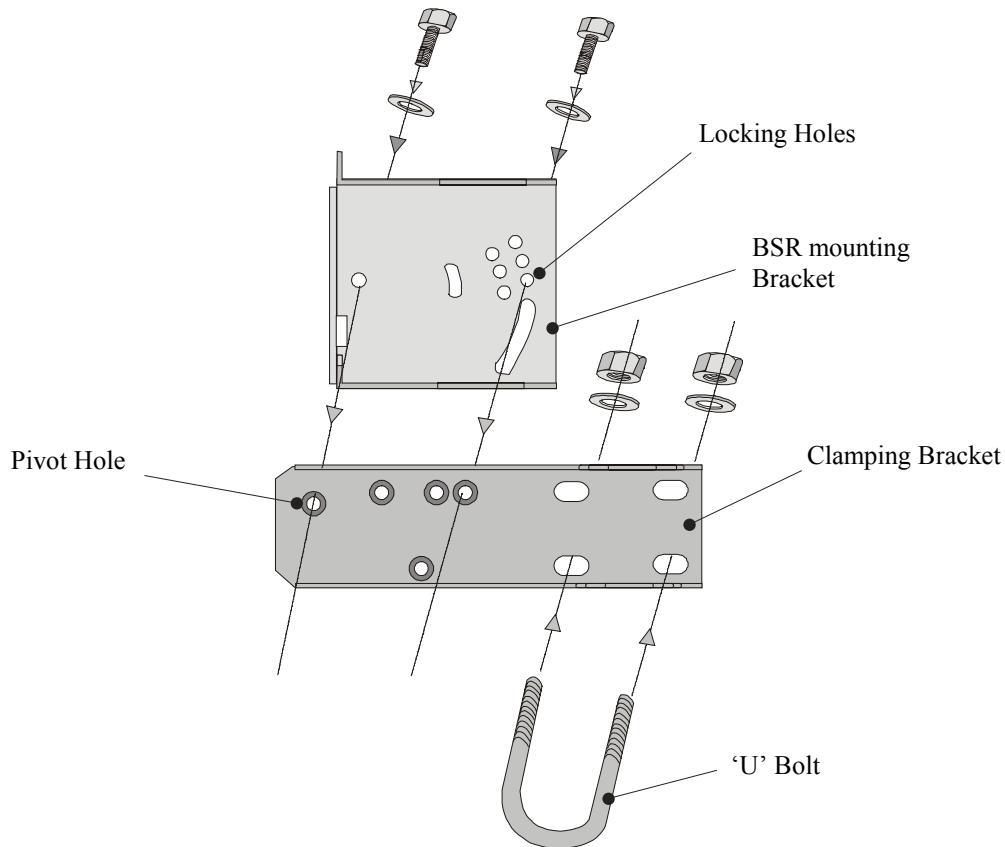

Figure 8-10: SPR mounting bracket assembly

2. Attach the clamping bracket to the mounting bracket using two M8 stainless bolts.
3. Attach the Clamping bracket to the pole by placing the U-bolt around the pole, and then inserting the U-bolt through the Clamping bracket and securing it by screwing the two bolts on the U-bolt.

4. Adjust the vertical position of the SPR. Lock the SPR at the desired position by inserting the locking bolt in the desired position. Once the correct angle has been set both bolts must be tightened to lock the SPR bracket in place.
5. Adjust the horizontal position of the SPR by rotating the SPR about the pole, and then tighten the U-bolt.

SPR positioning is obtained in two planes by adjustment of the mounting bracket assembly as shown in Figure 8-11.

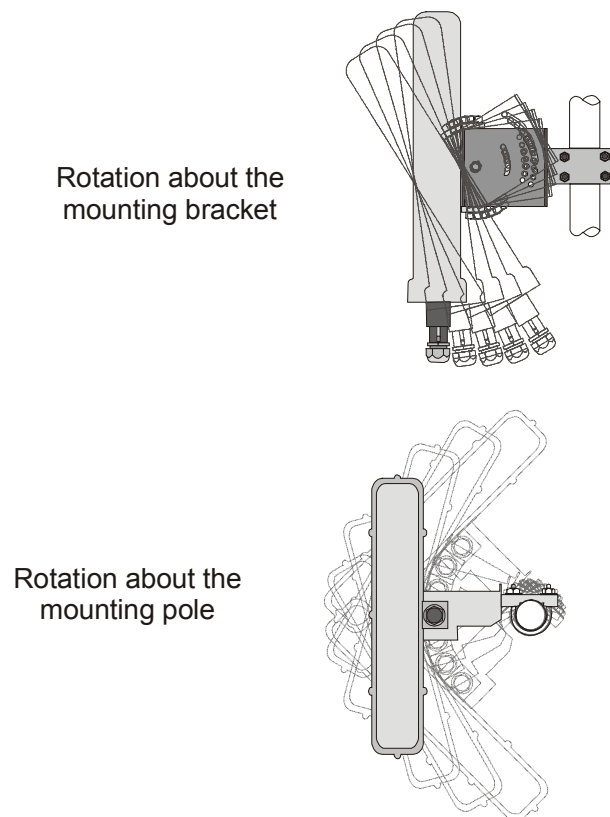

Figure 8-11: SPR GPS orientation in vertical (top figure) and horizontal plane (lower figure)



Note: A thread-locking compound is to be used to prevent the bolts working loose. A loop should be left in the cable for maintenance purposes and to prevent the cable weight being taken directly on the connector.

8.5. Connecting a Third-Party External Antenna (Optional)

The SPR model with an N-type connector can be connected to an external antenna. The addition of an external antenna allows greater RF sector coverage than the standard SPR internal antenna models (i.e., 60°).

- **Connector:** N-type male



Figure 8-12: Example of an N-type connector

- **Cable:** RF coaxial



Warnings:

- 1) Before connecting the external antenna, ensure that the SPR is NOT connected to the power source.
 - 2) Before powering on the SPR, ensure that some type of equipment such as an antenna or an RF attenuator is connected to the N-type receptacle. This eliminates the risk of burning the SPR device.
 - 3) It is the responsibility of the person installing the WipLL system to ensure that when using the outdoor antenna kits in the United States (or where FCC rules apply), that only those antennas certified with the product are used. The use of any antenna other than those certified with the product is expressly forbidden in accordance with FCC rules CFR47 part 15.204. The installer should configure the output power level of antennas according to country regulations and per antenna type
-
-

To connect the SPR to an external antenna:

- Attach an **N-type male** connector of the third-party antenna to the N-type receptacle located on the SPR's front panel.

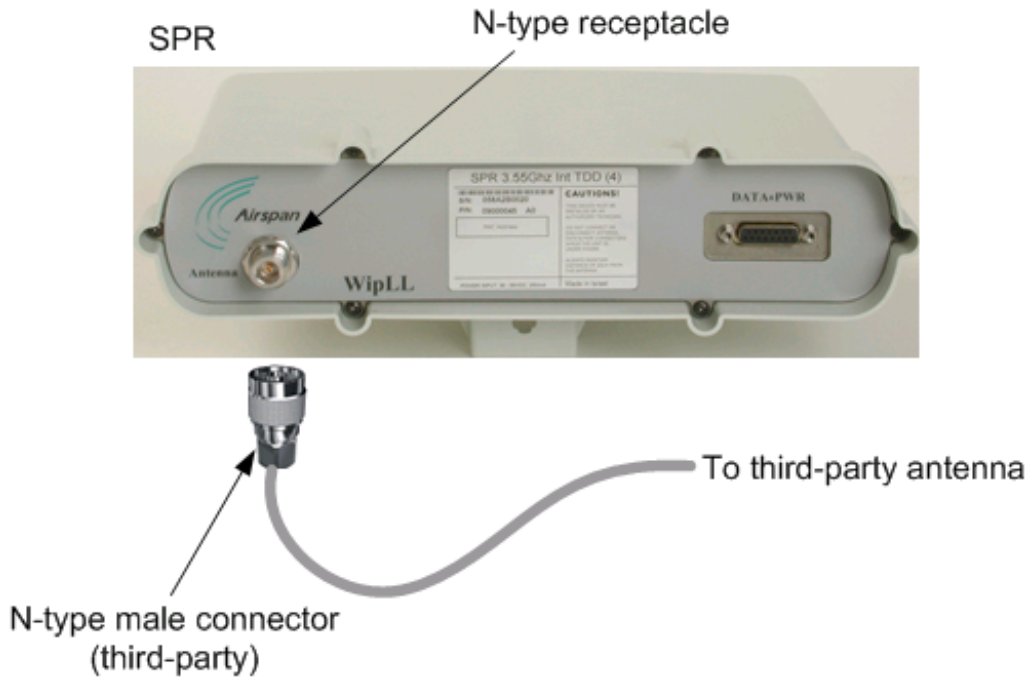

Figure 8-13: SPR model with N-type connector for attaching an external antenna



Note: Airspan supplies unterminated cables for N-type connectors. Refer to Appendix B, "Cable Crimping" for N-type cable crimping.

8.6. Connecting to the SDA

The SPR connects to the subscriber's PCs/network through the SDA. To connect the SPR to the SDA, you need to connect the SPR's 15-Pin D-type port to the SDA's 15-pin D-type port by a CAT-5e cable.

The SPR-to-SDA cable connection configurations is as follows:

■ Connectors:

- **SPR:** 15-pin D-type male (only 8 pins are used)
- **SDA:** 15-pin D-type male (only 8 pins are used)



Note: Airspan supplies unterminated CAT-5e cables. Refer to the cable crimping procedures for 15-Pin D-type connectors detailed in Appendix B, "Cable Crimping".

- **Cable:** straight-through 10Base-T Ethernet UTP 4 Pair **CAT-5e** outdoor type (24 AWG)
- **Connector pinouts:**

Table 8-2: SPR-to-SDA CAT 5 cable connector pinouts

15-pin D-type male	SPR		Wire color	Wire pair	SDA	
	Pin	Function			Pin	Function
	1	+48 VDC	Blue / white	1	1	+48 VDC
	2	-48 VDC	Blue		2	-48 VDC
	3	Tx+	Orange / white	2	3	Rx+
	4	Tx-	Orange		4	Rx-
	5	Rx+	Green / white	3	5	Tx+
	6	Rx-	Green		6	Tx-
	7	Sync.+	Brown / white	4	7	Sync.+
	8	Sync.-	Brown		8	Sync.-

**Notes:**

- Pins 9 through 15 of the 15-pin D-type connector are not used.
- The wire color-coding described in the table is WipLL's standard for wire color-coding. However, if you implement your company's wire color-coding scheme, ensure that the wires are paired and twisted according to the pin functions listed in Table 8-2 (e.g., Rx+ with Rx-).

WipLL uses the following wire color-coding standards for CAT 5 cables with 15-pin D-type to 15-pin D-type connectors on either ends (8 wires used):









	Pin	Straight-through	Pin	
+48 VDC	1		1	+48VDC
-48 VDC	2		2	-48VDC
Tx+	3		3	Rx+
Tx-	4		4	Rx-
Rx+	5		5	Tx+
Rx-	6		6	Tx-
	7		7	
	8		8	

Figure 8-14: WipLL wire color-coding for 15-pin D-type connectors

**Notes:**

- 1) The wires are twisted together in pairs, for example, blue/white with blue, and orange/white with orange. This prevents electrical interference between the transmitter pins. For example, pin 3 (Tx+; orange / white) is paired and twisted with pin 4 (Tx-; orange).
- 2) The SDA connector pinouts are the same for all SDA models (SDA-1, SDA-4H, SDA-4S, SDA-4S/VL, SDA-4S/VItag, SDA-4S/1H3L, and SDA-4S/VL/1H3L).



Warning: To avoid electrical shock, before connecting the SPR to the SDA, ensure that the SDA is not connected to the power supply.

To connect the SPR to the SDA:

1. Attach the **15-pin D-type** connector, at one end of the cable, to the SPR's 15-pin D-type port labeled **DATA POWER SYNC**, as displayed in Figure 8-15.
2. Attach the **15-pin D-type** connector, at the other end of the cable, to the SDA's **15-pin D-type** port, as displayed in Figure 8-15.

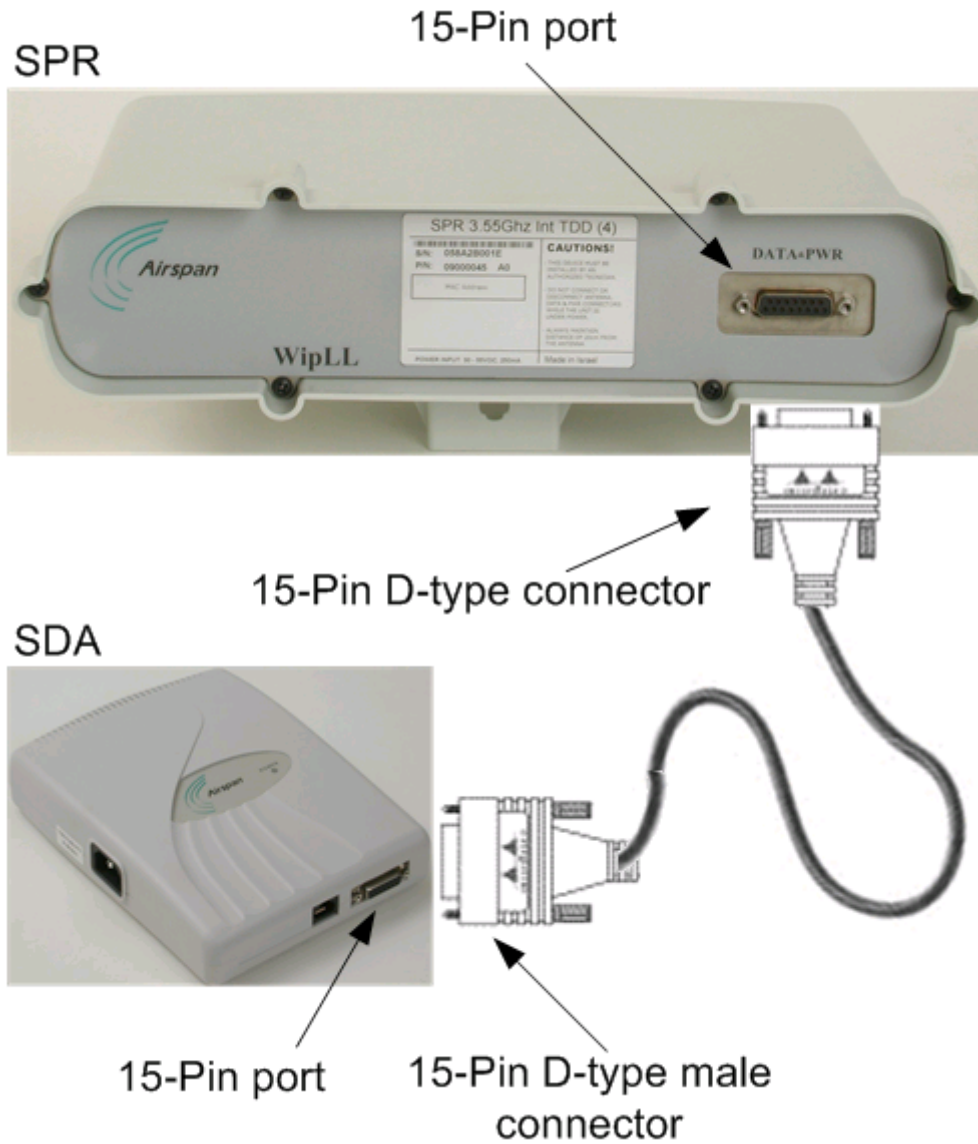

Figure 8-15: SPR-to-SDA cable connections



Note: The maximum cable length permissible between the SPR and SDA is 100 meters.

8.7. Connecting to a PC for Serial Configuration

To configure an SPR, you need to connect a PC running the WipLL network management system (WipConfig) to the SPR. The SPR's 15-pin D-type port provides serial interface to a PC for SPR initial configuration. This port uses 9 of its 15 pins for serial interface; the remaining pins are used for interfacing with the SDA with which the SPR remains connected. To connect the SPR to the management station (i.e., PC) and the SDA, a Y-cable (splitter) is used.



Note: SPR configuration is performed while the SDA is connected to the SPR.

The SPR-to-PC and SDA cable connections for SPR serial configuration are as follows:

- **Connectors:**
 - **SPR:** 15-pin D-type male (only 9-pins used)
 - **PC:** 9-pin D-type (RS-232)
 - **SDA:** 15-pin D-type male
- **Cable:** straight-through Y-cable

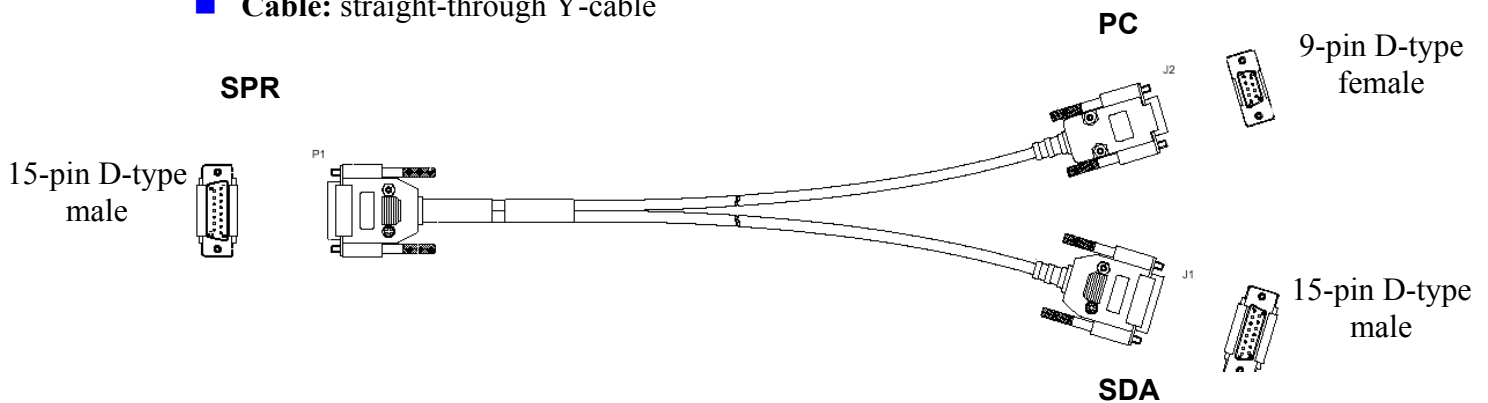

Figure 8-16: Y-cable for serial connection

■ Connector pinouts:

Table 8-3: Y-cable SPR-to-SDA connector pinouts

SPR			SDA		
15-pin D-type male	Pin	Function	Pin	Function	15-pin D-type male
	1	0 VDC	1	+48 VDC	
	2	+48 VDC	2	-48 VDC	
	3	Ethernet Tx+	3	Rx+	
	4	Ethernet Tx-	4	Rx-	
	5	Ethernet Rx+	5	Tx+	
	6	Ethernet Rx-	6	Tx-	
	7	Hop Sync+	7	Sync.+	
	8	Hop Sync-	8	Sync.-	

Table 8-4: Y-cable SPR-to-PC connector pinouts

SPR			PC		
15-pin D-type male	Pin	Function	Pin	Function	9-pin D-type female
	12	GND	5	GND	
	14	RS232 Rx	3	Rx	
	15	RS232 Tx	2	Tx	

The Y-cable connector pin assignments are displayed schematically in Figure 8-17.

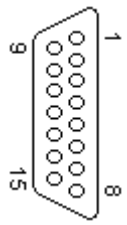
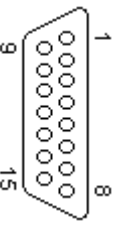
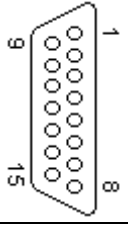
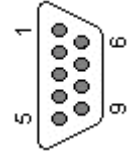
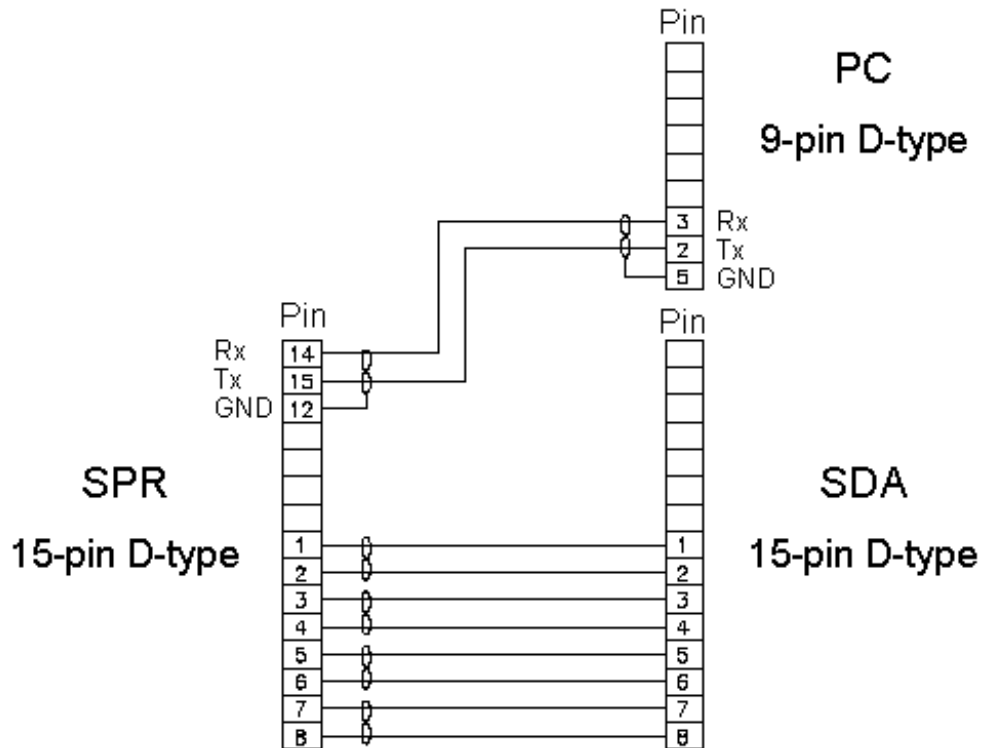

Figure 8-17: Y-cable connector pin assignment

To connect the SPR to a PC for serial configuration:

1. Connect the **15-pin D-type male** connector (P1), at the one end of the Y-cable, to the SPR, as displayed in Figure 8-18.
2. Connect the **15-pin D-type male** connector (J1), at the other end of the Y-cable, to the SDA, as displayed in Figure 8-18.
3. Connect the **9-pin D-type** (RS232) connector (J2), at the other end of the Y-cable, to the PC, as displayed in Figure 8-18.

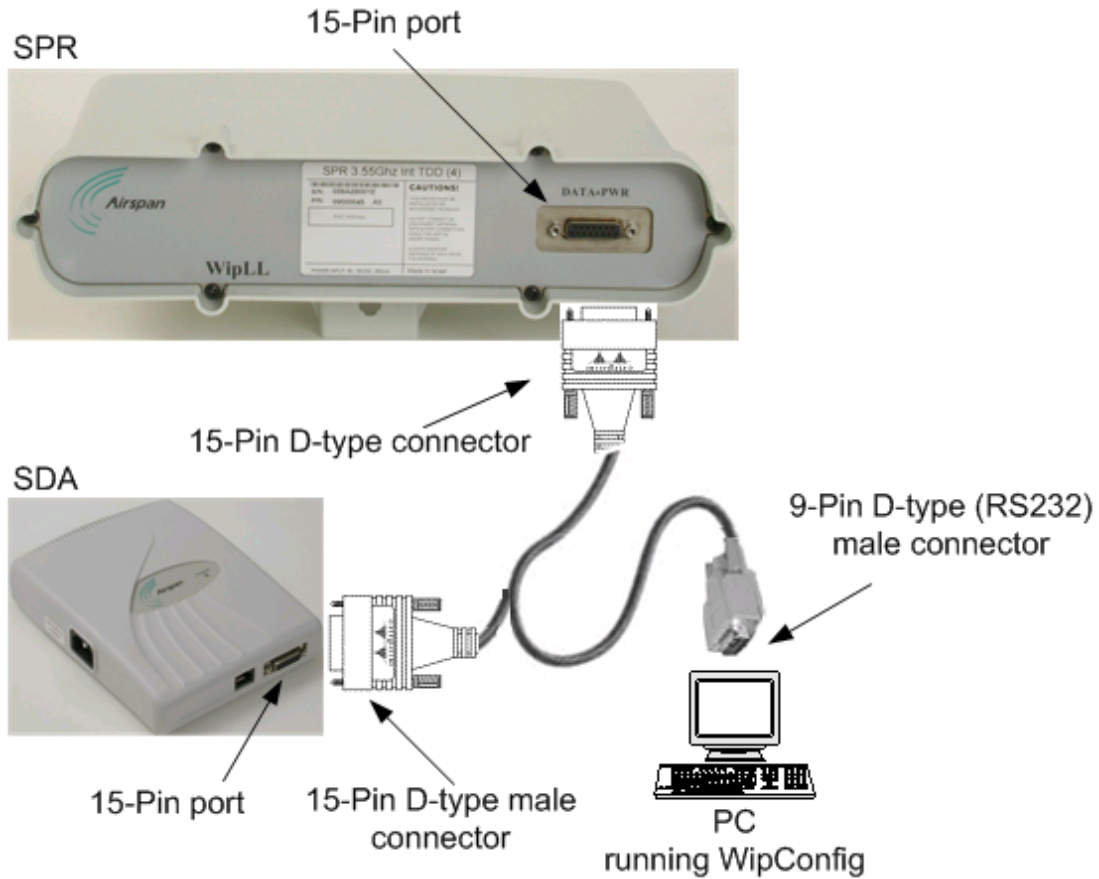

Figure 8-18: SPR cable connections for serial configuration



Note: For performing SPR initial configuration using WipLL's management applications, refer to Airspan's *WipConfig User's Guide* or *WipConfig PDA User's Guide*.

8.8. Connecting the RSS LED Adapter

The WipLL RSS LED adapter indicates the received signal strength (RSS) between the SPR and the BSR. This allows you to accurately position the SPR during installation for optimal radio frequency signal reception. The RSS LED adapter is connected between the SPR and SDA CAT 5 cable connection. The RSS LED adapter provides two 15-pin D-type ports: one for the SPR side; and the other for the SDA side. The RSS LED adapter can be connected in one of the following manners:

- The RSS LED adapter 15-pin D-type port connects directly to the SPR's 15-pin D-type port; while the other RSS LED adapter's 15-pin D-type port connects to the SDA via the CAT 5 cable.

-Or-

- Both 15-pin D-type ports of the RSS LED adapter connect to the SPR and SDA via a CAT 5 cable on either side.

The following describes the connectors, cable, and connector pinouts:

- **Connectors:**

- **SPR:** 15-pin D-type male (only 9-pins used)

- **RSS LED adapter:**

- SPR side: 15-pin D-type female
- SDA side: 15-pin D-type male

- **SDA:** 15-pin D-type male

- **Cables:** two straight-through cables for SPR-to-RSS LED adapter, and for SDA-to-RSS LED adapter.

To connect the RSSI LED adapter:

1. Connect the **15-pin D-type male** connector, at one end of the straight-through cable, to the SPR, as displayed in Figure 8-19.
2. Connect the **15-pin D-type female** connector, at the other end of the straight-through cable, to the RSS LED adapter, as displayed in Figure 8-19.
3. Connect the **15-pin D-type male** connector, at one end of the straight-through cable that originates from the SDA, to the RSS LED adapter, as displayed in Figure 8-19.

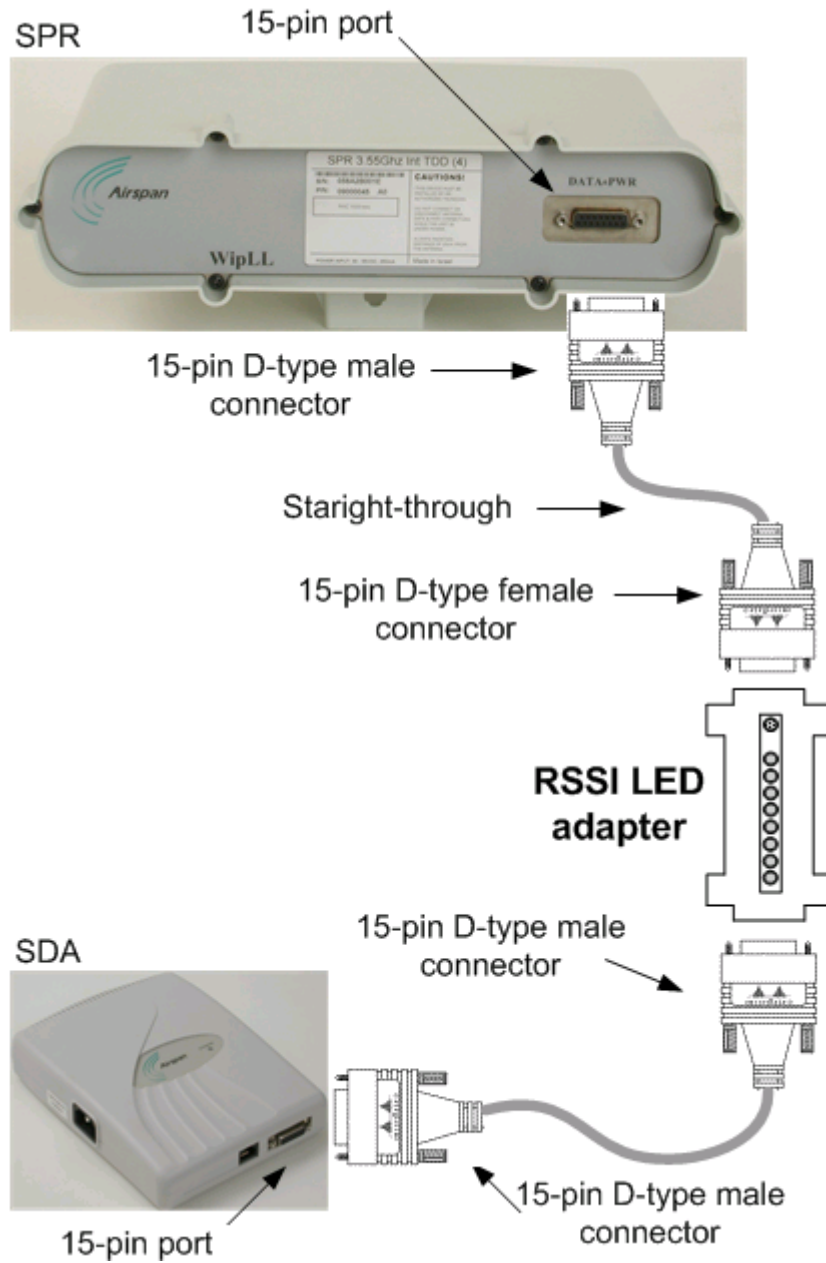

Figure 8-19: Connecting the RSS LED adapter



Note: You can connect the RSS LED adapter's 15-pin male port directly to the SPR's 15-pin port, instead of using a cable.

Table 8-5 describes the LEDs on the RSS LED adapter.

Table 8-5: LED description of the RSS LED adapter

LED	Color	Function	Status	Description
Power	Red	Power	On	The SPR receives power from the SDA
			Off	No power is supplied to the SPR by the SDA
			Blinking	Data transmission is occurring on the Ethernet LAN
RSS LEDs (LEDs 0 to 7)	Green	Received Signal Strength level	LED 1 blinking	$RSS \leq -94$ dBm
			LED 1 is on	-93 dBm \leq RSS \leq -90 dBm
			LEDs 1 and 2 are on	-89 dBm \leq RSS \leq -86 dBm
			LEDs 1, 2, and 3 are on	-85 dBm \leq RSS \leq -82 dBm
			LEDs 1, 2, 3, and 4 are on	-81 dBm \leq RSS \leq -78 dBm
			LEDs 1, 2, 3, 4, and 5 are on	-77 dBm \leq RSS \leq -74 dBm
			LEDs 1, 2, 3, 4, 5, and 6 are on	-73 dBm \leq RSS \leq -70 dBm
			LEDs 1, 2, 3, 4, 5, 6 and 7 are on	-69 dBm \leq RSS \leq -66 dBm
			All LEDs are on	RSS \geq -65 dBm

8.9. Connecting Power

The SPR receives, through its 15-pin D-type port, its power supply from the SDA. In turn, the SDA connects to an external power adapter from where it receives power. The SDA provides 48 VDC nominal power to the SPR (minimum of 30 VDC: maximum of 55 VDC).



Warning: If you are using an external antenna, ensure that you connect the antenna before connecting the SPR to the power source.



Note: For a description of the procedure for connecting power to the SDA, see Chapter 9, "Installing the SDA".



Installing the SDA

This chapter describes the installation of the WipLL **Subscriber Data Adapter (SDA)** at the subscriber's premises.

This chapter includes the following chapters:

- Overview
- Physical Dimensions and Basic Design
- Mounting the SDA
 - Desktop-Mounting
 - Wall-Mounting
- Connecting to the SPR
- Connecting to the Subscriber's Ethernet Network
 - Connecting to PCs
 - Connecting to a Hub
 - Connecting to a VoIP Network
- Connecting AC Power
- LED Display
 - SDA-4H
 - SDA-4S Models

9.1. Overview

The SDA is an Ethernet hub/LAN switch that provides the SPR with DC power, lightning protection, and Ethernet connectivity to the subscriber's PCs/network. The SDA connects to the SPR by a CAT-5 cable.

The SDA provides 10/100BaseT connectivity (depending on the SDA model) to the subscriber's PCs or network (up to four PCs depending on the SDA model).

The SDA is located inside the subscriber's premises, typically mounted on a wall or simply placed on a desktop.

The SDA is available in six models:

- **SDA-1:** This is a hub that provides one 10BaseT interface (RJ-45 port) with the subscriber's PC and/or network (via a hub or LAN switch).
- **SDA-4H:** This is a hub and provides four 10BaseT ports for interfacing with the subscriber's PCs/network. In addition, one of the 10BaseT ports provides crossover configuration for crossover-cable connection for interfacing with, for example, other hubs.
- **SDA-4S models:** Integrated LAN switches, providing four 10/100BaseT interfaces with the subscriber's PCs/network. The ports of the SDA-4S models support **Auto Negotiation**, allowing automatic configuration for the highest possible speed link: 10BaseT or 100BaseT, and Full Duplex or Half Duplex mode. In other words, the speed of the connected device (PC) determines the speed at which packets are transmitted through the specific port. For example, if the device (i.e, PC) to which the port is connected is running at 100 Mbps, the port connection will transmit packets at 100 Mbps. If the device (i.e, PC) to which the port is connected is running at 10 Mbps, the port connection will transmit packets at 10 Mbps. In addition, the SDA-4S ports support **MDI/MDI-X** automatic crossover, allowing connection to straight-through or crossover CAT-5 cables
 - **SDA-4S (standard):** Standard integrated LAN switch, providing four 10/100BaseT interfaces to the subscriber's computers.

- **SDA-4S/VL:** Provides VLANs between its ports and the SPR, ensuring privacy between users of different ports (i.e., multi-tenant VLAN security). For example, all users connected to Port 1 do not “see” users connected to Port 2.
- **SDA-4S/VLtag:** This model is ideal for multi-tenant applications where traffic engineering and privacy is required. SDA-4S/VLtag assigns the traffic from each of its four ports with a different VLAN ID. The VLAN IDs are fixed (since SDA-4S/VLtag is not user configurable). SPR converts the four VLAN IDs tagged by SDA-4S/VLtag to four VLAN IDs configured via WipLL’s NMS. The tag conversion is performed by SPR before sending the traffic to the air and the other way around when coming from the air.
- **SDA-4S/1H3L:** Provides a high priority port (left-most port) for VoIP traffic.
- **SDA-4S/VL/1H3L:** Combines the functionality of the SDA-4S/VL and SDA-4S/1H3L models (VLAN for each port and a high priority port for VoIP).

Figure 9-1 displays a typical setup of the SPR and SDA at the subscriber's premises.



Note: The SDA can also be installed at a base station that has only one BSR. This SDA replaces the need for the BSDU, and provides power and connectivity to the single BSR.

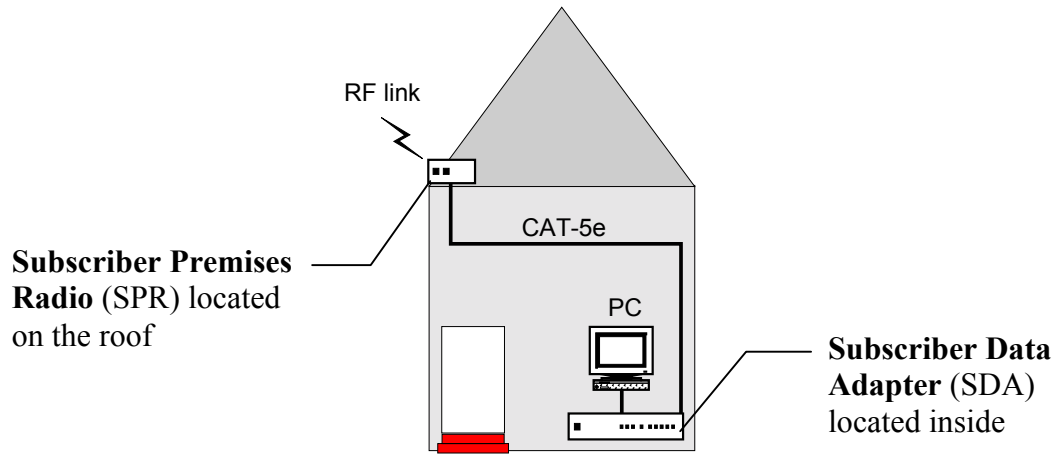

Figure 9-1: Typical SPR and SDA location and connections at subscriber's premises

9.2. Physical Dimensions and Basic Design

The SDA is encased in a chassis. The chassis front panel provides access to the SDA's communication ports. The left-side of the chassis provides a power connector port for connection to an external power adapter. The SDA's bottom panel provides holes for mounting the SDA on a wall

Figure 9-2 displays the SDA-4S models and the SDA-4H.

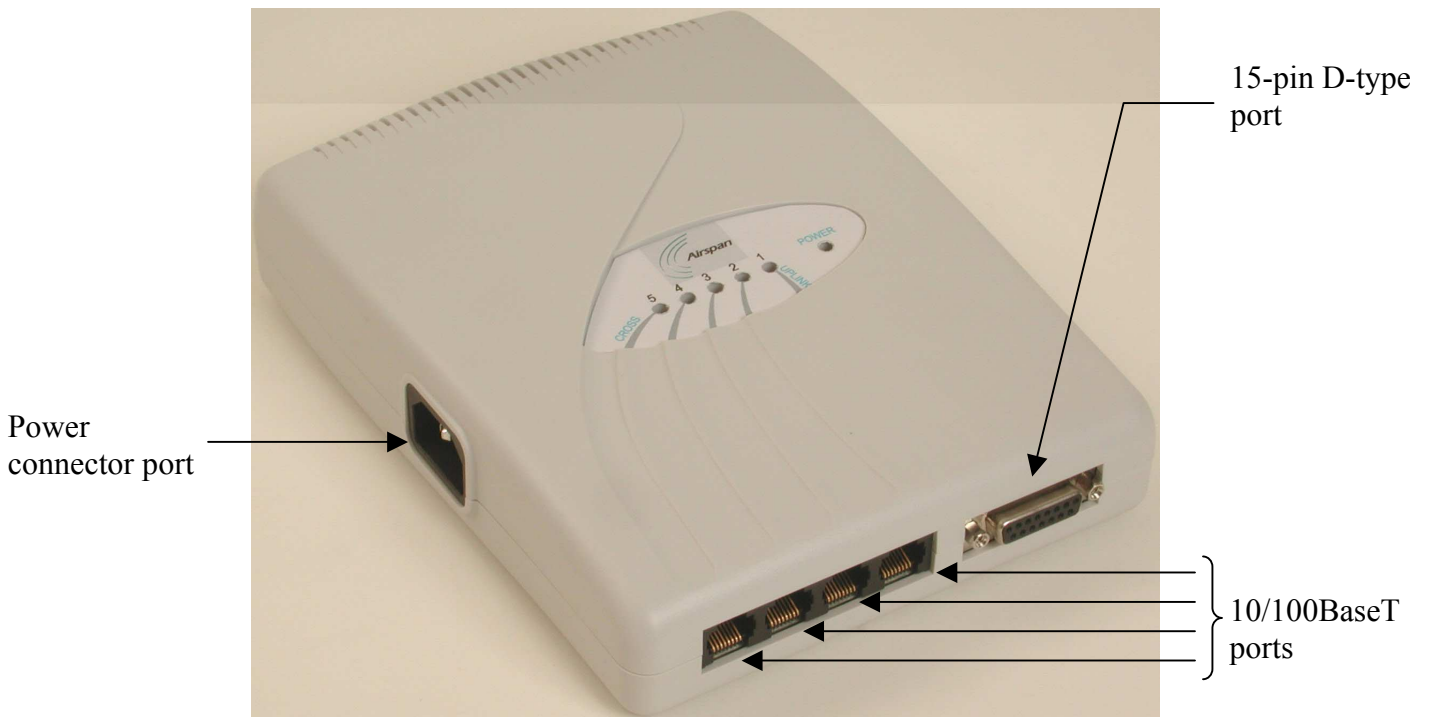

Figure 9-2: SDA-4S models and SDA-4H (front, side, and top panels)

Figure 9-3 displays the SDA-1 model.



Figure 9-3: SDA-1 (front, side, and top panels)

The SDA's physical dimensions are described in Table 9-1

Table 9-1: SDA physical dimensions

Parameter	Value
Height	200 mm (7.87 inches)
Width	150 mm (5.9 inches)
Depth	40 mm (1.57 inches)
Weight	0.53 kg

9.3. Mounting the SDA

The SDA can be wall or desk mounted.

9.3.1. Desktop-Mounting

For desk mounting (horizontal mounting), the chassis' bottom panel provides four rubber feet on each corner.



Warning: For desk mounting, do not place the SDA on a carpeted surface where airflow is restricted and a fire hazard may result.



Figure 9-4: SDA - rear panel

9.3.2. Wall-Mounting

For SDA wall mounting, two mounting hooks are molded into the chassis' bottom panel (see Figure 9-4). The dimensions of the SDA's wall-mounting hooks, located on the chassis bottom panel, are displayed in Figure 9-5.

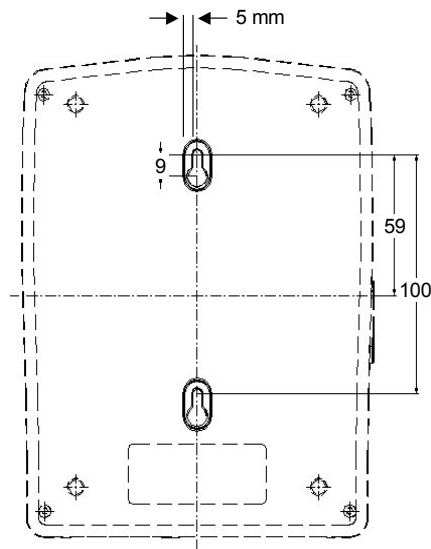

Figure 9-5: SDA mounting footprint details



Notes:

- 1) Airspan does not supply screws for wall mounting as the size and type of screws depends on the type of wall at the subscriber's premises
 - 2) For reasons of safety both fixing points must be utilized when mounting the unit.
 - 3) The SDA is supplied with a 1-metre AC power lead assembly. Therefore, the unit must be located within reachable distance of the customer's mains power outlet.
 - 4) The cable must be dressed tidily and not be taught or pose a trip hazard when connected.
 - 5) The maximum cable run between an SDA and an SPR is 100 meters.
-

9.4. Connecting to the SPR

The SDA's 15-pin D-type port connects to the SPR's 15-pin D-type port by a CAT-5 cable.



Note: For a detailed description on connecting the SDA to the SPR, see Chapter 8, "Installing the SPR".

9.5. Connecting to the Subscriber's Ethernet Network

The SDA provides RJ-45 port(s) for Ethernet connectivity to the subscriber's PCs/network. The number of Ethernet ports and the speed of the Ethernet connection depend on the SDA model. Table 9-2 describes the number of ports and transmission speeds supported by the various SDA models.

Table 9-2: Number of ports and transmission speed of SDA models

SDA Model	RJ-45 Ports	Speed (Mbps)
SDA-1	1	10
SDA-4H	4	10
SDA-4S models (SDA-4S; SDA-4S/VL; SDA-4S/Vltag; SDA-4S/1H3L; SDA-4S/VL/1H3L)	4	10/100

The following list describes the location of the Ethernet ports for the various SDA models:

- **SDA-1:** one RJ-45 port (see Figure 9-6)

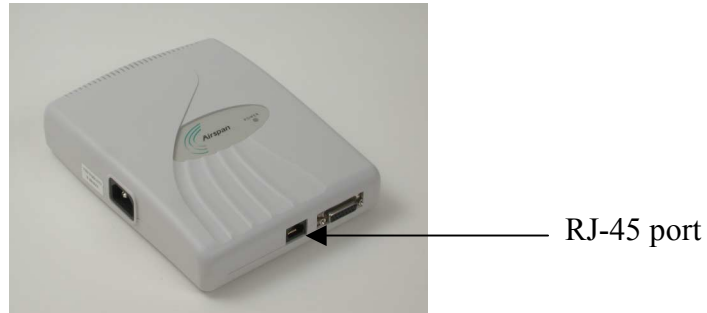

Figure 9-6: SDA-1 with one Ethernet port

- **SDA-4H:** four RJ-45 ports (see Figure 9-7).



Note: The left-most port (J5) is a crossover port.

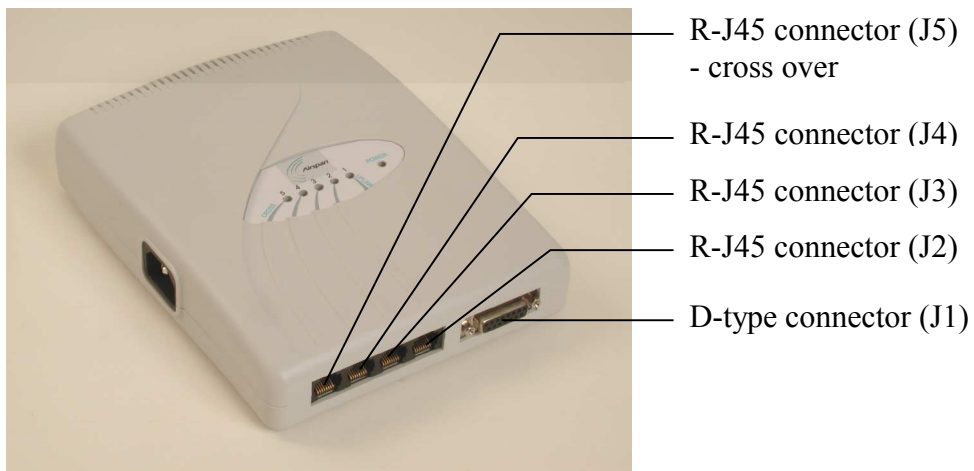

Figure 9-7: SDA-4H with four Ethernet ports

- **SDA-4S models (SDA-4S, SDA-4S/VL, SDA-4S/Vltag, SDA-4S/1H3L, and SDA-4S/VL/1H3L):** four 10/100BaseT RJ-45 ports. These ports support 10/100 Mbps autonegotiation, and MDI/MDI-X automatic crossover. This allows you to connect straight-through or crossover CAT-5 cables to these ports.

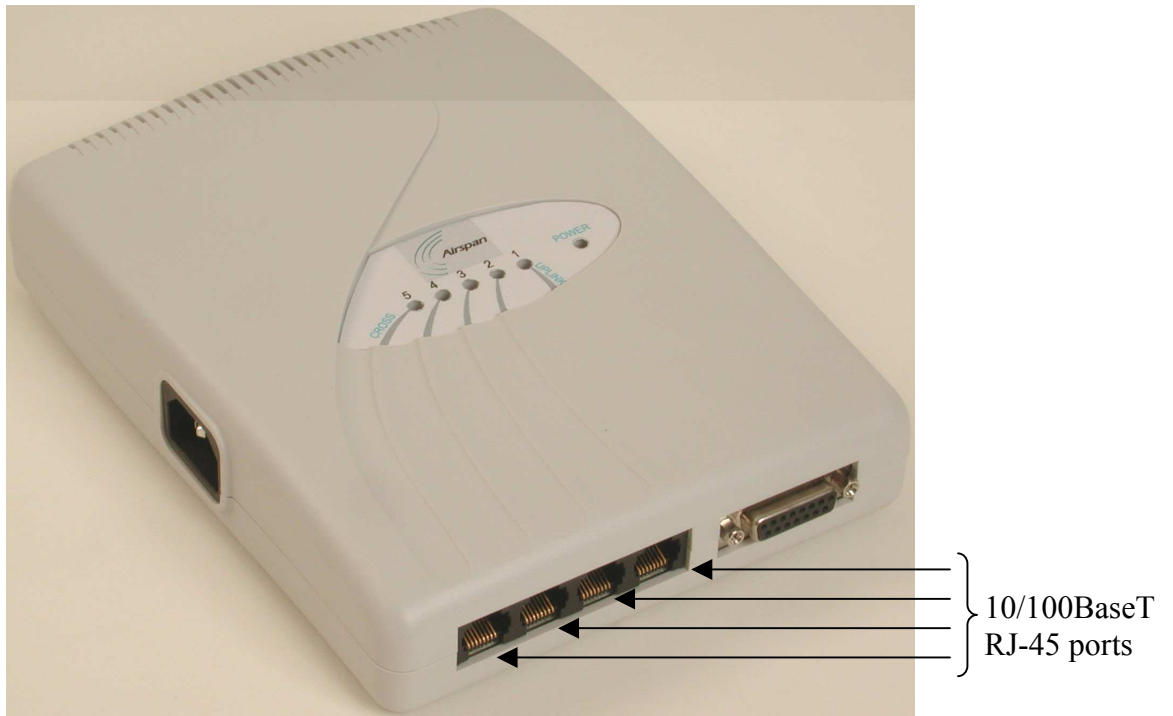

Figure 9-8: SDA-4S RJ-45 Ethernet Ports

9.5.1. Connecting to PCs

The SDA connects to the subscriber's PC(s) through the SDA's Ethernet port (RJ-45).



Note: To avoid electrical or fire hazard, ensure that the data connections to the SDA is made prior to connecting the power supply.

The SDA-to-subscriber PC cable configurations are as follows:

- **Connector:** 8-pin RJ-45
- **Cable:** straight-through Ethernet cable
- **Connector Pinouts:**

RJ-45: SDA-1, SDA-4H (J2, J3, J4), SDA-4S	
Pin	Function
1	+RX
2	-RX
3	+TX
4	NC
5	NC
6	-TX
7	NC
8	NC

RJ-45 crossover cables: SDA-4H (J5)	
Pin	Function
1	+Tx
2	-Tx
3	+Rx
4	NC
5	NC
6	-Rx
7	NC
8	NC

To connect the SDA to the subscriber's PC(s):

1. Connect the **8-pin RJ-45 male** connector, at the one end of the Ethernet cable, to the SDA's RJ-45 Ethernet port (see Figure 9-9).
2. Connect the **8-pin RJ-45 male** connector, at the other end of the Ethernet cable, to the subscriber's PC (or device). (See Figure 9-9.)

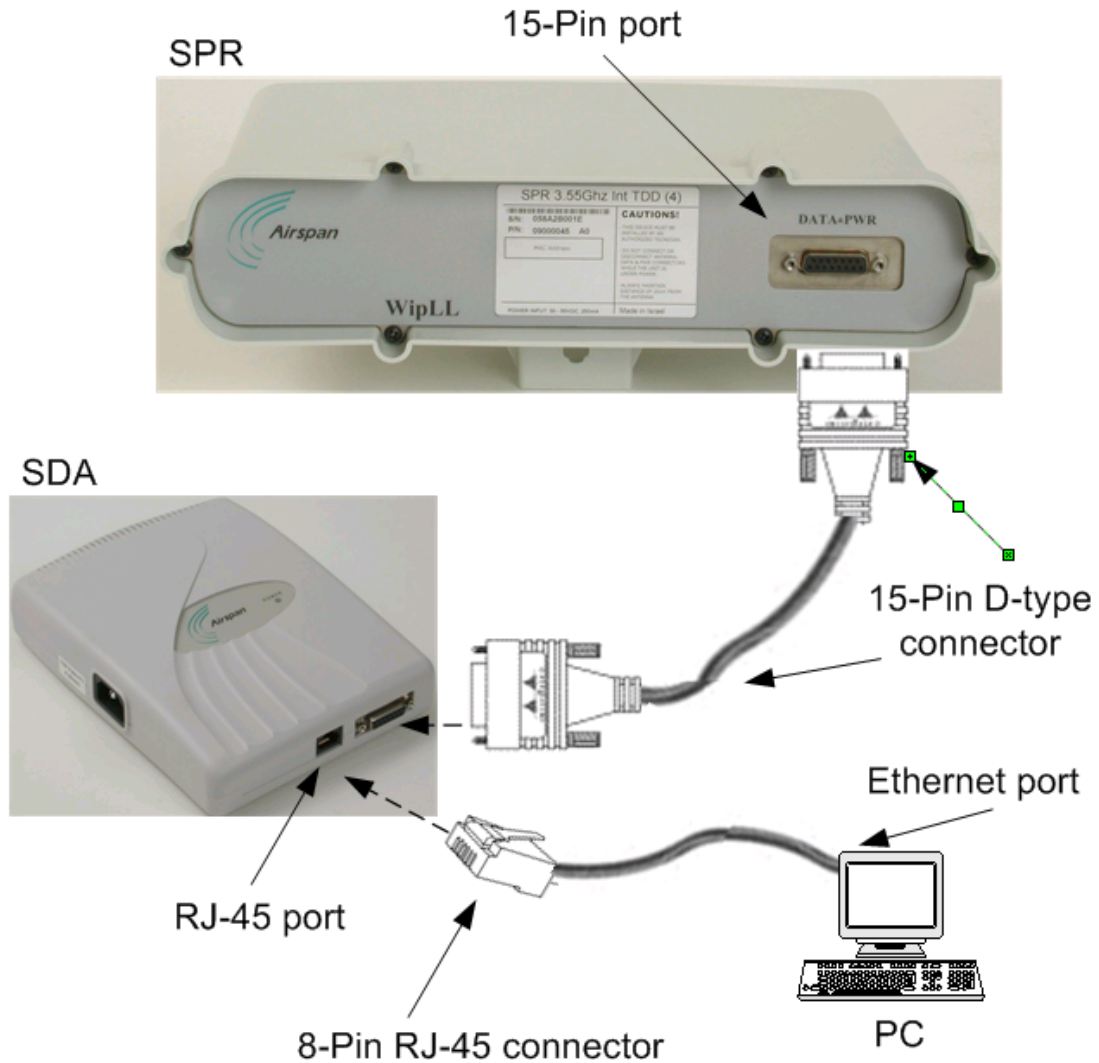

Figure 9-9: SDA-to-PC Cable Connections



Note: The SDA-4S RJ-45 ports support MDI/MDI-X automatic crossover. This means that straight-through or crossover CAT-5 cables can be connected to these ports.

9.5.2. Connecting to a Hub

The SDA-4S models and SDA-4H can be connected to another hub (for example, for daisy chaining). The ports of the SDA-4S models support MDI/MDI-X automatic crossover, allowing connection of straight-through or crossover cables. However, for the SDA-4H model, only the left-most RJ-45 port (J5) is a crossover port (see Figure 9-7).

The SDA-4S and SDA-4H cable configurations for connectivity to a hub, are as follows:

- **Connector:** 8-Pin RJ-45
- **Cable:**
 - **SDA-4H:** crossover-cable
 - **SDA-4S models:** straight-through or crossover cables (due to MDI/MDI-X ports)
- **Connector pinouts:** SDA-4H:

SDA-4H RJ-45 (J5)	
Pin	Function
1	+TX
2	-TX
3	+RX
4	NC
5	NC
6	-RX
7	NC
8	NC

To connect SDA-4S or SDA-4H to a hub:

1. Connect the RJ-45 male, at one end of the cable, to the SDA-4H's left-most RJ-45 port (J5), or any SDA-4S's RJ-45 port.
2. Connect the RJ-45 male, at the other end of the cable, to the hub.

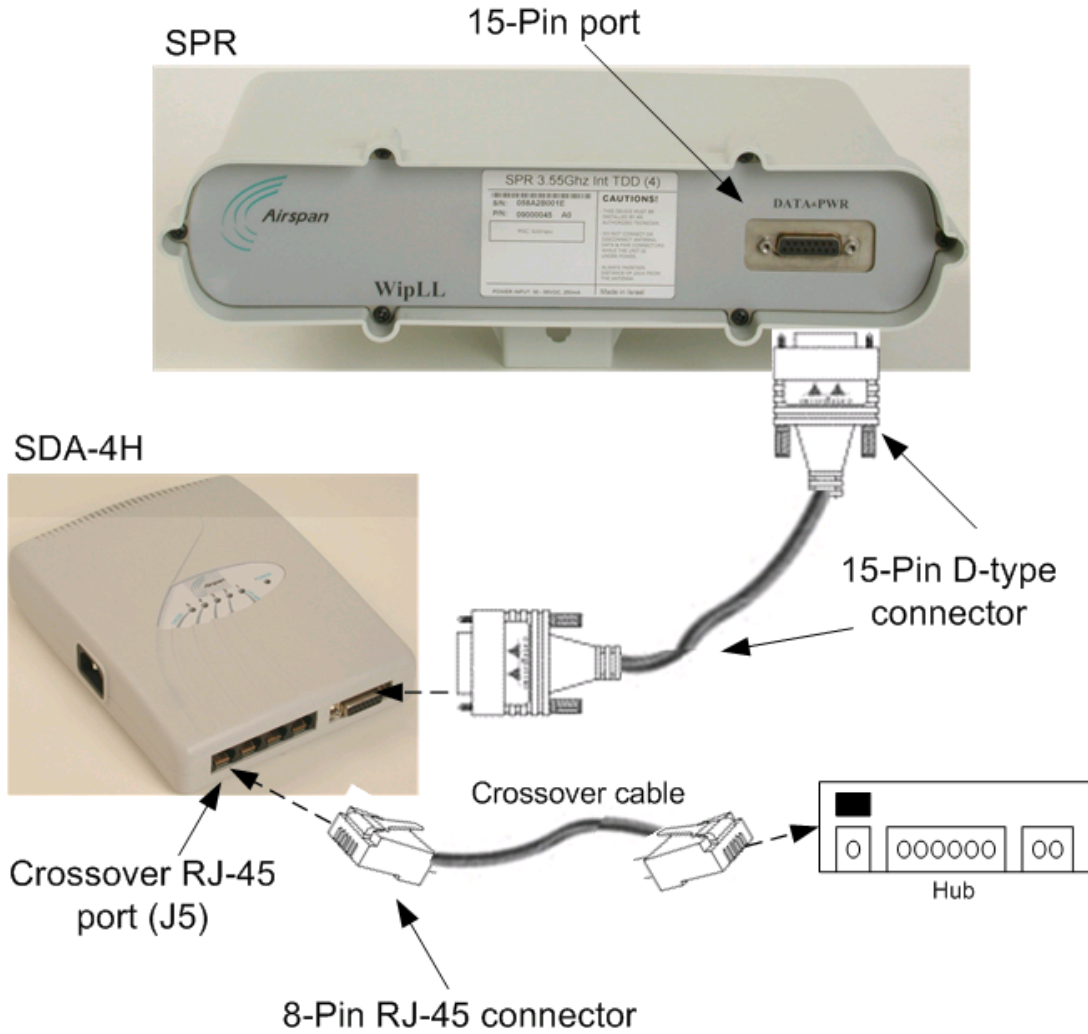

Figure 9-10: SDA-4H crossover cable connections to hub

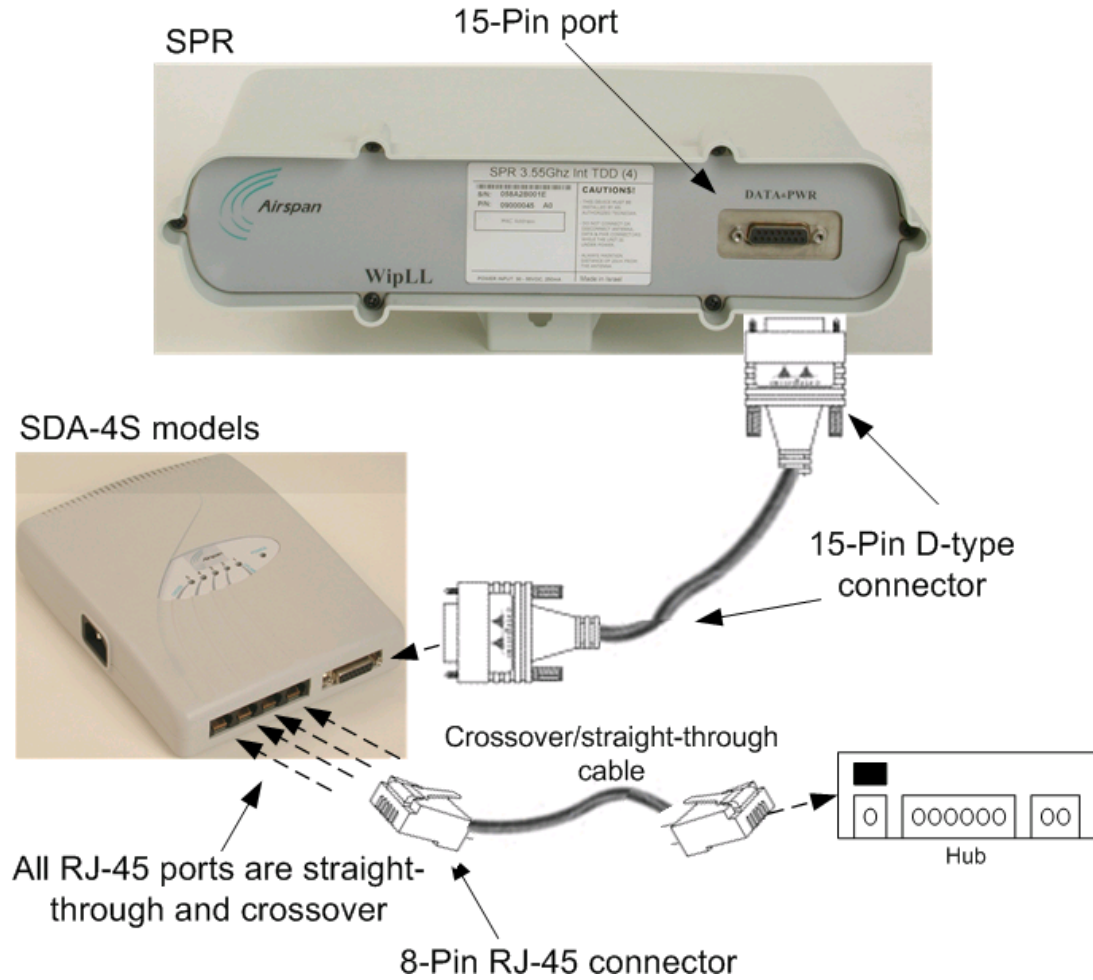

Figure 9-11: SDA-4S crossover/straight-through cable connections to hub



Note: The SDA-4S RJ-45 ports support MDI/MDI-X automatic crossover. Therefore, crossover CAT-5 cables can be connected to any of the ports.

9.5.3. Connecting to a VoIP Network

The **SDA-4S/1H3L** and **SDA-4S/VL/1H3L** model's left-most RJ-45 Ethernet port assigns high priority to VoIP traffic. This port is used to connect to the subscriber's VoIP network. This port assigns high priority to VoIP traffic, as opposed to the other RJ-45 ports, which assigns lower priority.

The cable connections for connecting the **SDA-4S/1H3L** and **SDA-4S/VL/1H3L** models to the subscriber's VoIP network, are as follows:

- **Connector:** 8-pin RJ-45 male
- **Cable:** straight-through or crossover
- **Connector pinouts:**

RJ-45 (left-most port)	
Pin	Function
1	+RX
2	-RX
3	+TX
4	NC
5	NC
6	-TX
7	NC
8	NC

To connect to the VoIP network:

1. Connect the RJ-45 male connector, at the one end of the Ethernet cable, to the left-most RJ-45 port on the front panel of the **SDA-4S/1H3L** and **SDA-4S/VL/1H3L** chassis (see Figure 9-12).
2. Connect the RJ-45 male connector, at the other end of the cable, to the VoIP network, for example, to a Residential Gateway (see Figure 9-12).

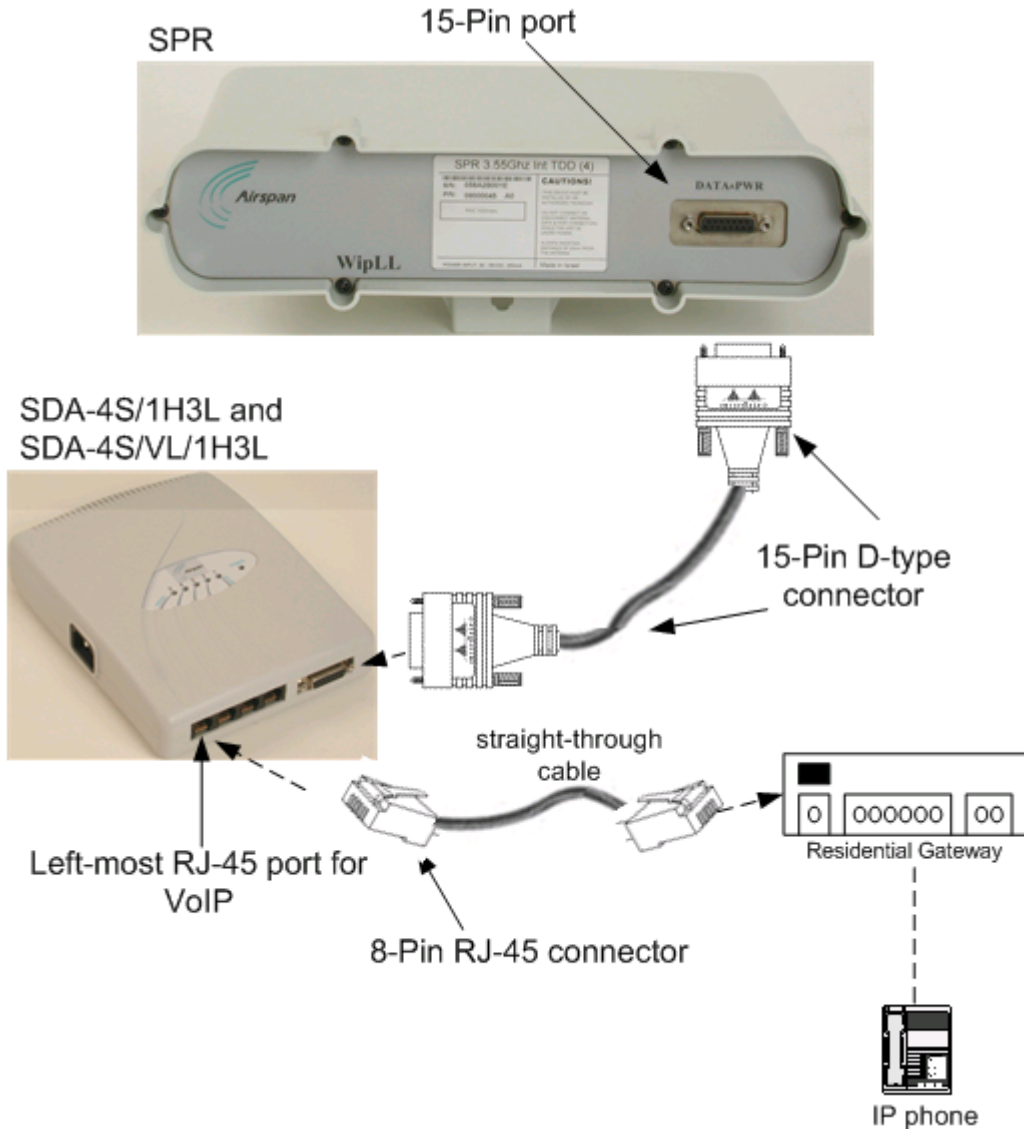

Figure 9-12: Connecting VoIP RJ-45 Port (for SDA-4S/1H3L and SDA-4S/VL/1H3L)

9.6. Connecting AC Power

The SDA receives AC power by connecting to a standard 110–240 VAC wall outlet. In turn, the SDA provides 48 VDC nominal power to the SPR (minimum of 30 VDC: maximum of 55 VDC).

Table 9-3 lists the SDA power supply specifications.

Table 9-3: SDA Power Supply Specifications

Power parameter	Units
Voltages	110-240 VAC
Frequency	50/60 Hz
Amps	0.3-0.7A

The following lists the cable connection between the SDA and the power outlet:.

- **Connector:** AC IEC 320 type (female)

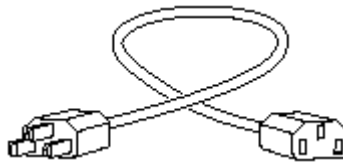

Figure 9-13: Power Chord

- **Cable:** 3-core 0.7mm² type (maximum length is 1.5 m)

For all SDA models, the power port is located on the left-panel of the chassis, as displayed in Figure 9-14 for SDA-1, and in Figure 9-15 for SDA-4H and SDA-4S models.



Figure 9-14: Location of SDA-1 power port

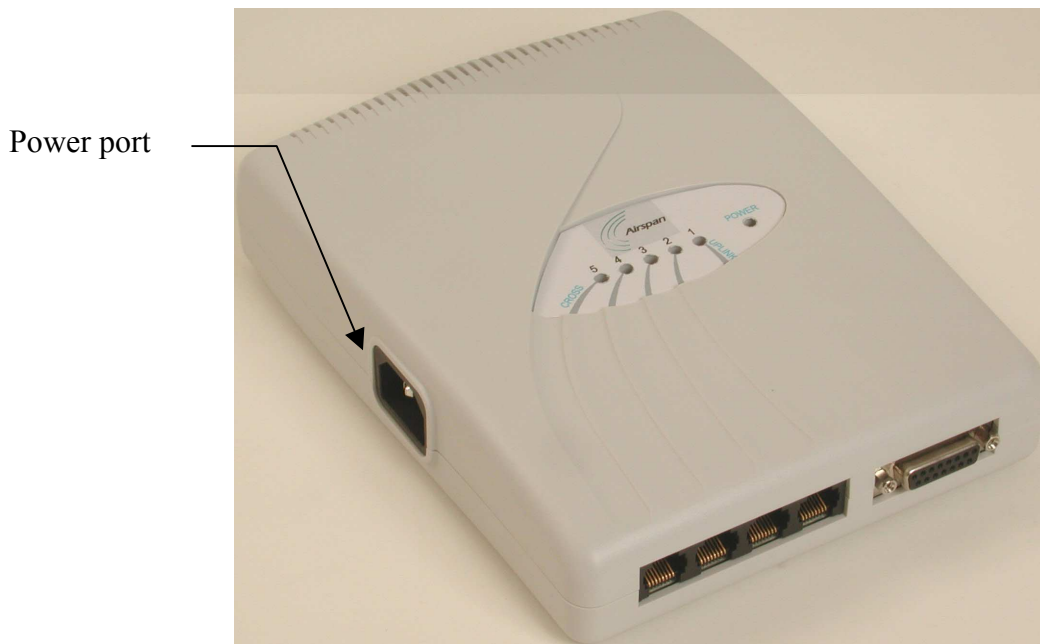

Figure 9-15: Location of SDA-4S model's and SDA-4H power port



Warning: Ensure that plugs fitted to mains power leads for subscriber premises equipment are compatible with AC mains sockets. Do not replace plugs on power leads to suit local requirements without first verifying grounding practice for the country and equipment in question.

Careful consideration must be given to issues including local wiring requirements, cable color-coding, safety grounding, and circuit protection requirements.

Prior to connecting to the power outlet, the following pre-connection inspection should be performed on power sockets:

- Power socket shall be visually inspected to ensure that no other equipment is connected to the power outlet.
- No damage to the power outlet.
- No water or dampness on or around the power outlet.
- The power outlet shall be checked using a proprietary plug tester such as a “Martindale Ze” type. Checks are required to verify the earth loop impedance value and the presence of phase, neutral, and earth connections.



Note: To avoid electrical or fire hazard, ensure that the data connections to the SDA is made prior to connecting the SDA to the power supply.

To connect the SDA to AC power supply:

1. Plug the power plug female, at the end of the AC power chord, into the power plug male located on the left of the SDA chassis (see Figure 9-16).
2. Plug the power plug male, at the other end of the AC power chord, into the wall power outlet (110-240 VAC). (See Figure 9-16.)
3. Verify that the power is received by the SDA by checking that the **POWER** LED light (green) is on.

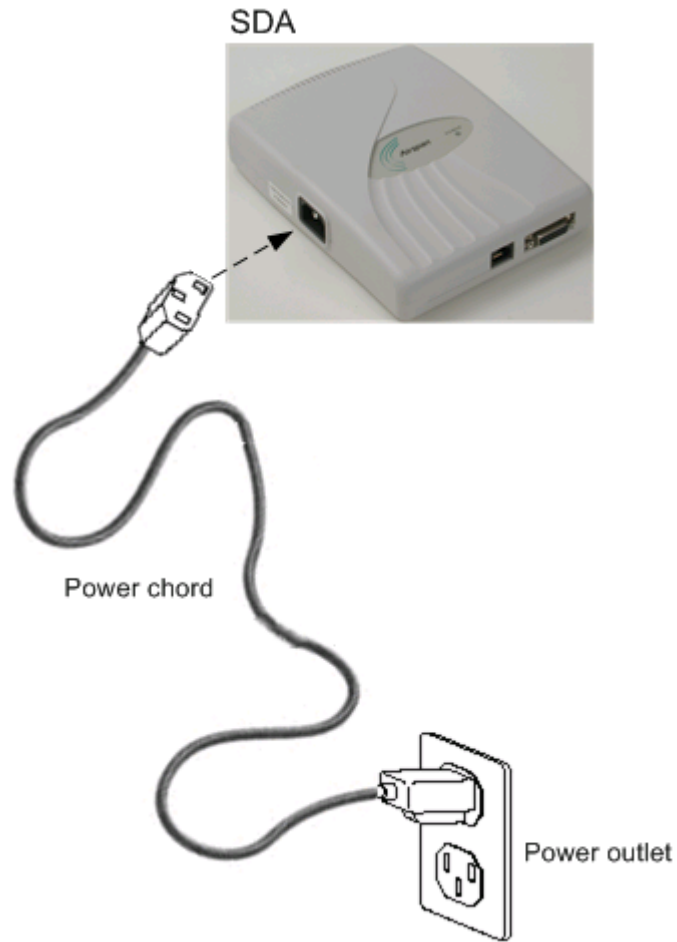

Figure 9-16: SDA power cable connections

9.7. LED Display

The SDA-4H and SDA-4S models provide LED indicators that indicate network connection, traffic status, and power. These LEDs are located on the top panel of the chassis.

9.7.1. SDA-4H

Figure 9-17 displays the location of the SDA-4H LED indicators.

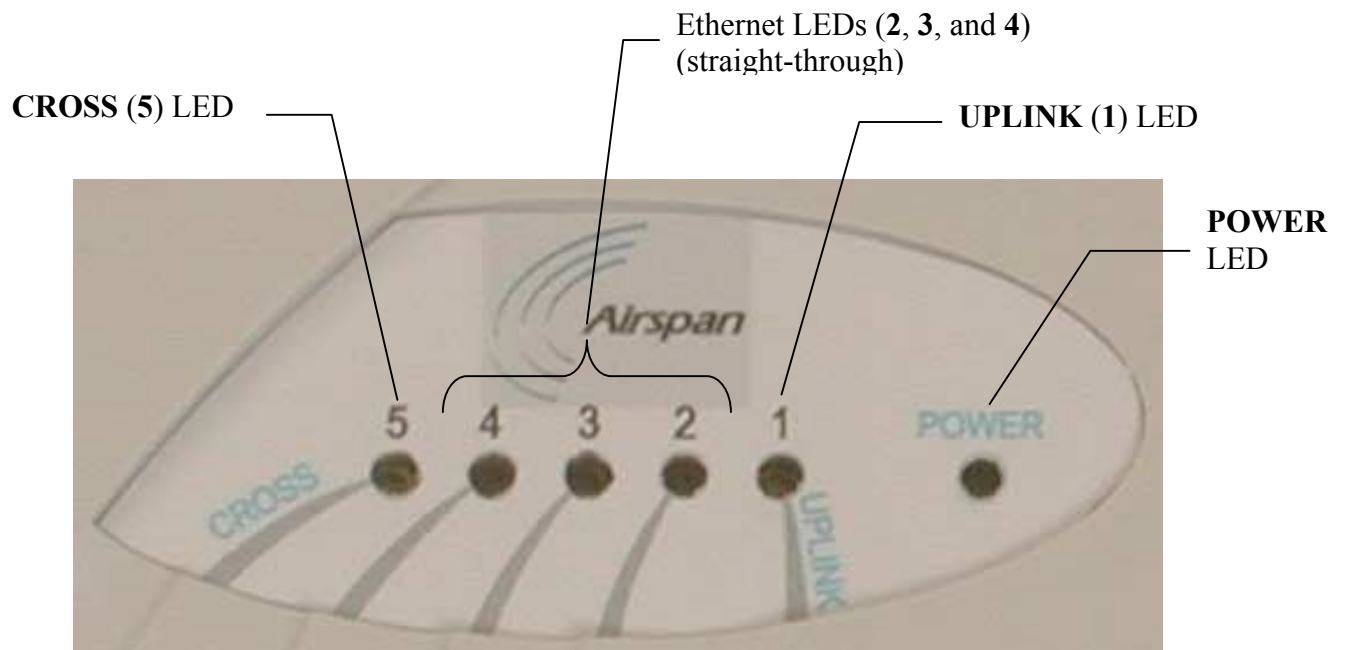

Figure 9-17: SDA-4H LED indicators

Table 9-4 describes the SDA-4H LED indicators.

Table 9-4: Description of the SDA-4H LED Indicators

LED	Color	Status	Meaning
1 (UPLINK)	Yellow	On	Physical link between SDA-4H and SPR
		Blinking	Traffic flow between SDA-4H and SPR
		Off	No link between SDA-4H and SPR
2, 3, and 4	Yellow	On	Physical link between SDA-4H and Ethernet network
		Blinking	Traffic flow between SDA-4H and Ethernet network
		Off	No link between SDA-4H and Ethernet network
5 (CROSS)	Yellow	On	Physical link between SDA-4H and crossover Ethernet port connection
		Blinking	Traffic flow between SDA-4H and crossover Ethernet port network
		Off	No link between SDA-4H and crossover Ethernet port connection
POWER	Green	On	Power received by the SDA-4H.
		Off	No power received by SDA-4H

9.7.2. SDA-4S Models

Table 9-5 describes the SDA-4S model's LED indicators.

Table 9-5: Description of the SDA-4S model's LED indicators

LED	Color	Status	Meaning
1	Orange	On	Physical link (10BaseT) between SDA-4S and SPR
		Blinking	Traffic flow between SDA-4S and SPR
		Off	No link between SDA-4S and SPR
2, 3, 4, and 5	Green	On	100BaseT physical link between SDA-4H and Ethernet network
		Blinking	100BaseT traffic flow between SDA-4H and Ethernet network
		Off	No traffic flow between SDA-4S and Ethernet network
	Orange	On	10BaseT physical link between SDA-4H and Ethernet network
		Blinking	10BaseT traffic flow between SDA-4H and Ethernet network
		Off	No traffic flow between SDA-4S and Ethernet network
POWER	Green	On	Power received by the SDA-4S model.
		Off	No power received by SDA-4S model.



Installing the IDR

This chapter describes the installation of the WipLL **Indoor Data Radio (IDR)**, which is installed at the base station.

This chapter includes the following sections:

- Overview
- Physical Dimensions and Basic Design
- Mounting the IDR
 - Desk Mounting
 - Wall and Pole Mounting
- Connecting a Third-Party External Antenna
- Connecting to an Ethernet Network
- Positioning IDR for Optimum RF Reception
- Connecting to PC for Serial Configuration
- Connecting Power
 - Power LEDs

10.1. Overview

The IDR device is an optional WipLL device that combines the functionality of the SPR and SDA devices. The IDR has a built-in antenna that provides an interface for transmission with the base station. In addition, the IDR provides an interface for 10Base-T Ethernet with the subscriber's network. However, unlike the SDA, a separate power supply unit (power adapter) powers the IDR.

The IDR is available in two models:

- IDR with an internal antenna
- IDR with a TNC connector for connecting to a third-party external antenna

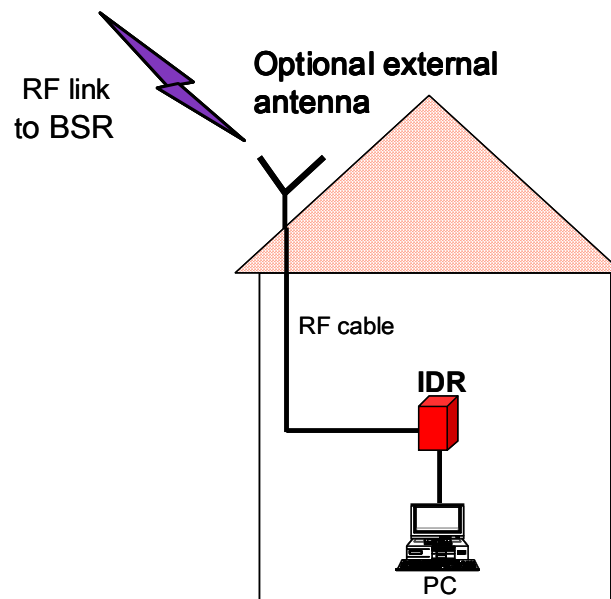

Figure 10-1: Typical IDR setup at subscriber's premises (showing optional antenna)



Warning: To avoid electrical or fire hazard, ensure that all connections to the IDR are performed prior to connecting the power supply.



Note: The digital portion of the transceiver has been tested and found to comply with the limits for a Class B digital device, pursuant to part 15 of the FCC rules. These limits are designed to provide reasonable protection against harmful interference in a residential installation. This equipment generates, uses, and can radiate radio frequency energy and, if not installed and used in accordance with the instructions, may cause harmful interference to radio communications. However, there is no guarantee that interference will not occur in a particular installation. If this equipment does cause harmful interference to radio or television reception, which can be determined by turning the equipment on and off, the user is encouraged to try correct the interference by performing one or more of the following measures:

- Reorientate or relocate the receiving antenna
 - Increase separation between the equipment and receiver
 - Connect the equipment to an outlet on a circuit different from that to which the receiver is connected
 - Consult the dealer or an experienced radio/TV technician for help
-
-

10.2. Physical Dimensions and Basic Design

The IDR is encased in a chassis providing access to the IDR's communication port at the front panel.

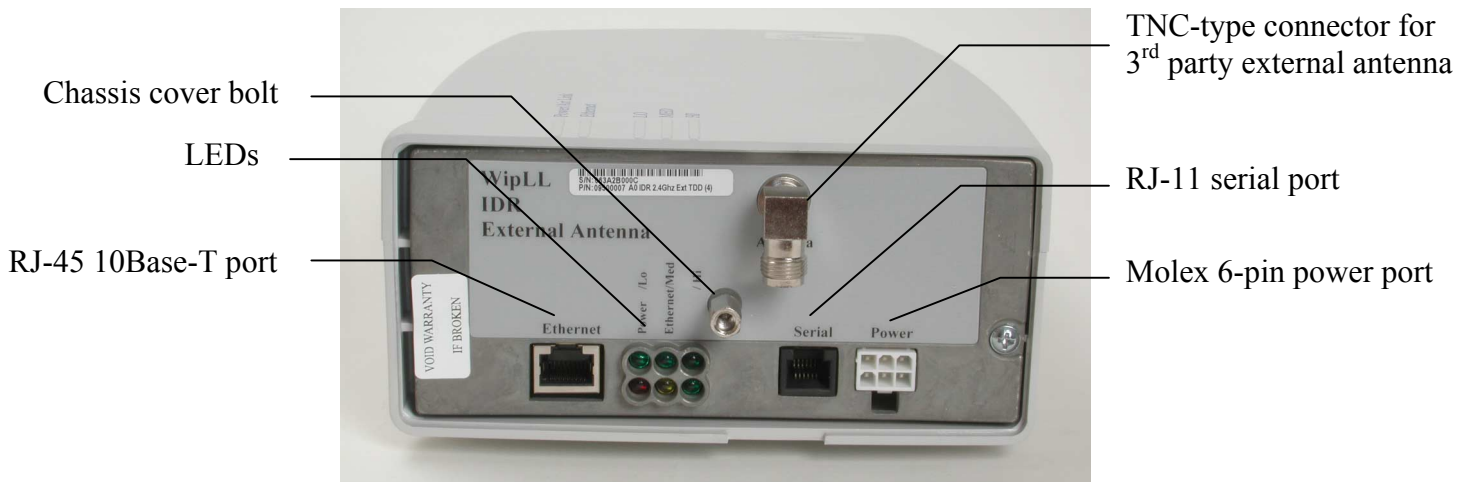

Figure 10-2: IDR front panel with cover removed exposing ports

The IDR's physical dimensions are described in Table 10-1.

Table 10-1: IDR physical dimensions

Parameter	Value	Comment
Weight	1,43 kg	
Dimensions (H x W x D)		Note: Dimensions exclude the external power adapter.
<ul style="list-style-type: none"> IDR with built-in antenna 	<ul style="list-style-type: none"> 155 mm (6.1 inches) x 233 mm (9.17 inches) x 74.5 mm (2.93 inches) 	
<ul style="list-style-type: none"> IDR with an external antenna 	<ul style="list-style-type: none"> 120.5 mm (4.74 inches) x 61mm (2.4 inches) x 35 mm (1.37 inches) 	

10.3. Mounting the IDR

The IDR may be mounted in the following ways:

- Desk
- Pole
- Wall



Note: Before mounting or attaching any brackets to the IDR, ensure that all cables are securely attached and that the unit functions correctly in the proposed location.

10.3.1. Desk Mounting

The IDR may be mounted on a desk in one of the following ways:

- Vertically
- Horizontally

10.3.1.1. Vertical-Desk Mounting

A base plate is provided to mount the unit vertically on the desk, i.e., in standing position. The base plate is designed to fit in one position only.

To desk mount the IDR in a vertical position:

- Insert the IDR into the base and press firmly until the tabs click into place. See Figure 10-3.

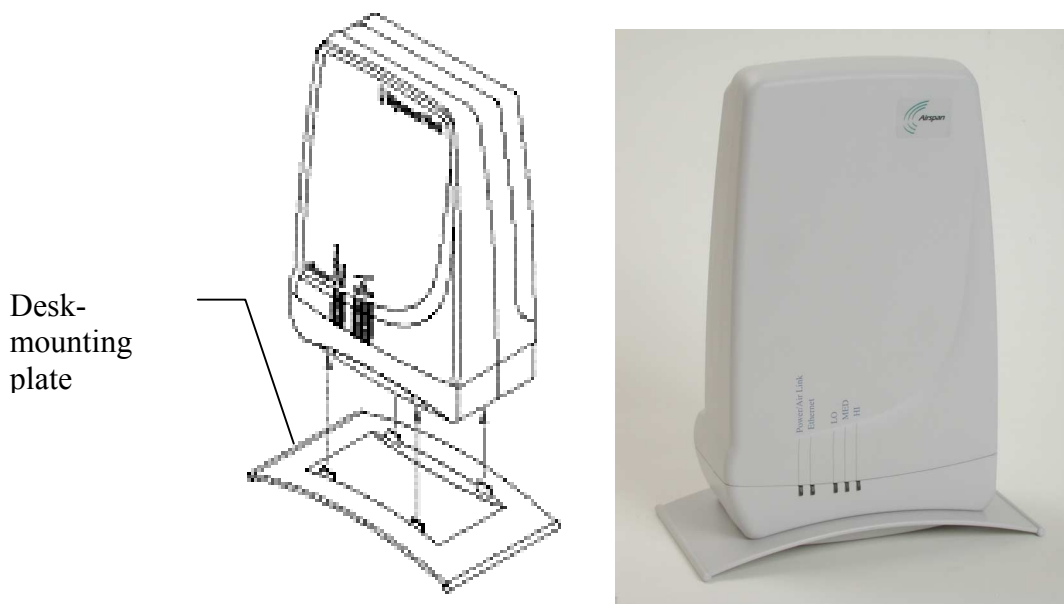

Figure 10-3: IDR vertical desk mounting

10.3.1.2. Horizontal-Desk Mounting

To position the IDR horizontally on the desk, four rubber pads, supplied with the unit, must be fitted to avoid damage to mounting surfaces.

To desk mount the IDR in a horizontal position:

- Secure the rubber pads to the posts provided on the rear of the IDR using four self-tapping screws. See Figure 10-4.

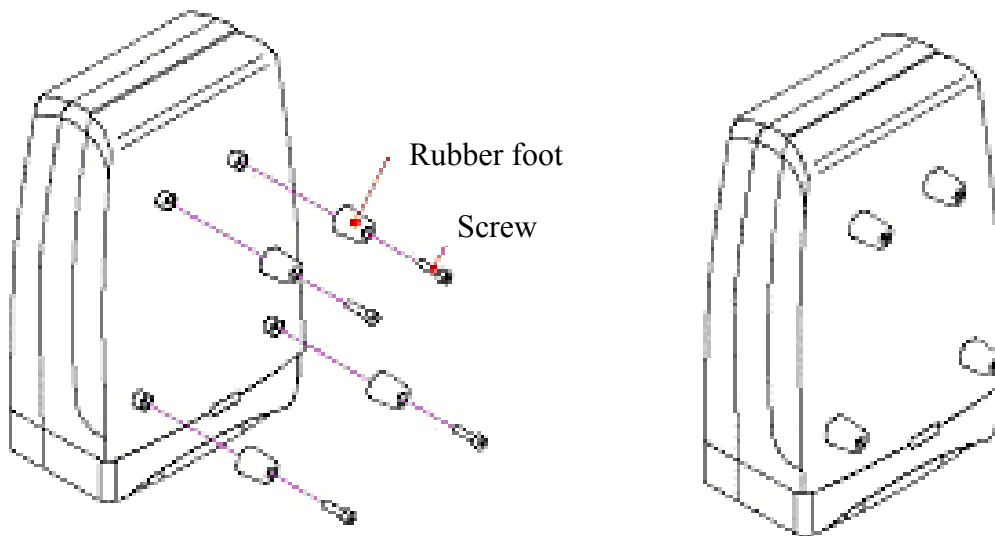

Figure 10-4: IDR horizontal desk mounting using supplied rubber pads and tapping screws

10.3.2. Wall and Pole Mounting

The IDR may be mounted to a wall or to a 5-cm diameter pole. Wall and pole mounting both use the same mounting brackets and wall hanger plate.

10.3.2.1. Assembling the Bracket and Hanger Plate

The wall hanger plate secures the IDR to a wall or pole. The wall bracket and hanger plate allows positioning the IDR in the correct orientation. Holes are provided in the wall hanger plate for both pole and wall mounting options

To assemble the bracket and hanger plate:

1. Insert a 4 mm hex nut into the slot on the tilt arm component
2. Holding the nut in place, attach the tilt arm to the mounting bracket using a 4 mm socket head bolt. Hand tighten the bolt only. See Figure 10-5.
3. Affix the complete mounting assembly to the rear of the IDR using the 4-off self-tapping screws supplied with the kit.

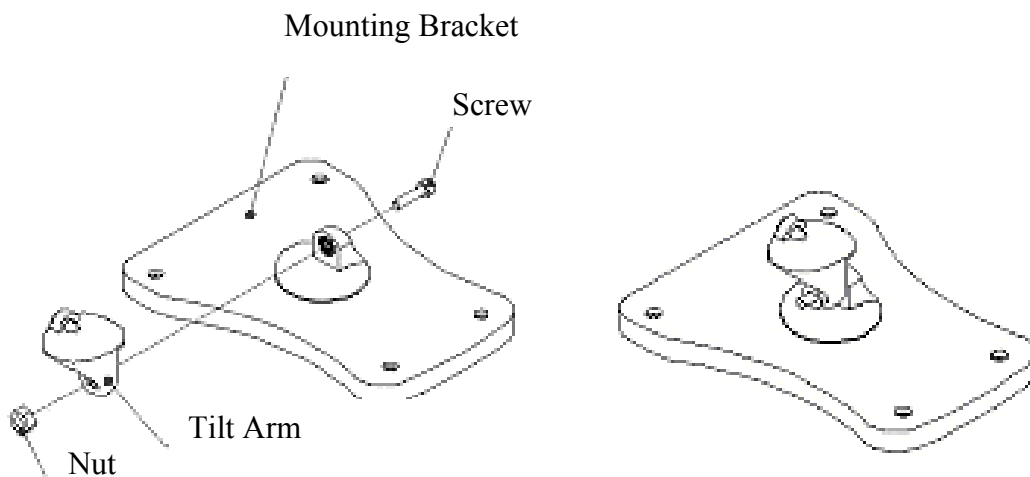

Figure 10-5: Mounting bracket assembly

4. Attach the wall bracket assembly to wall hanger using an M4 socket-head bolt and nut as shown in Figure 10-6. The bolt is only to be hand tightened at this stage.

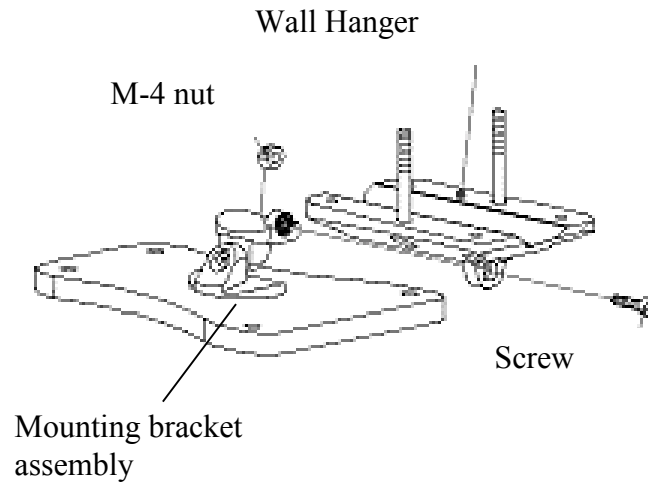

Figure 10-6: Wall hanger fixing method

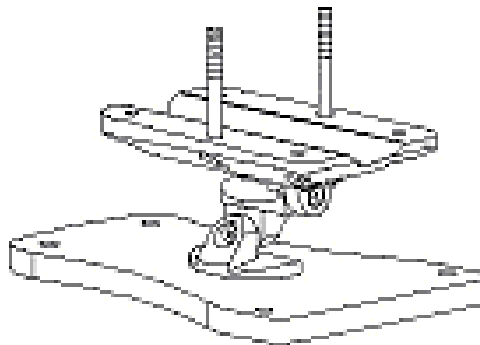

Figure 10-7: Wall hanger & mounting bracket assembly

5. Once assembled, the IDR mounting bracket assembly may be secured to the rear of the IDR using the 4-off self-tapping screws supplied in the unit fixing kit. See Figure 10-8.

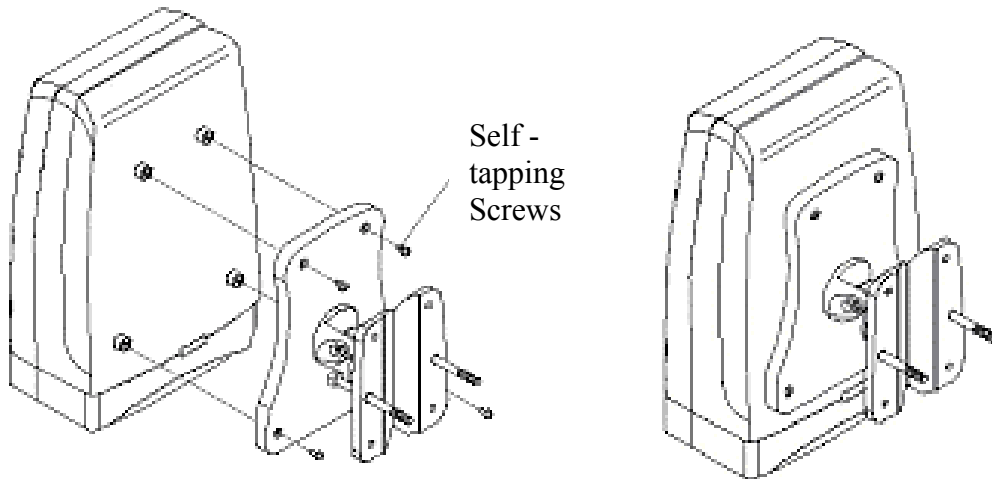

Figure 10-8: Mounting bracket assembly secured to IDR

10.3.2.2. Pole Mounting

Prior to mounting the IDR to a pole the wall mounting bracket assembly must be fitted as described in the previous section.

To pole mount the IDR:

1. Offer up the IDR assembly to the pole as shown in Figure 10-9.
2. Insert 2-off M10 bolts through the holes in the wall hanger.
3. Slide the clamp-holder into position and secure using washers, spring-washers and nuts as illustrated in Figure 10-10. Finger-tighten the fasteners.
4. Slide the IDR to the required location on the pole and fully tighten the fasteners.

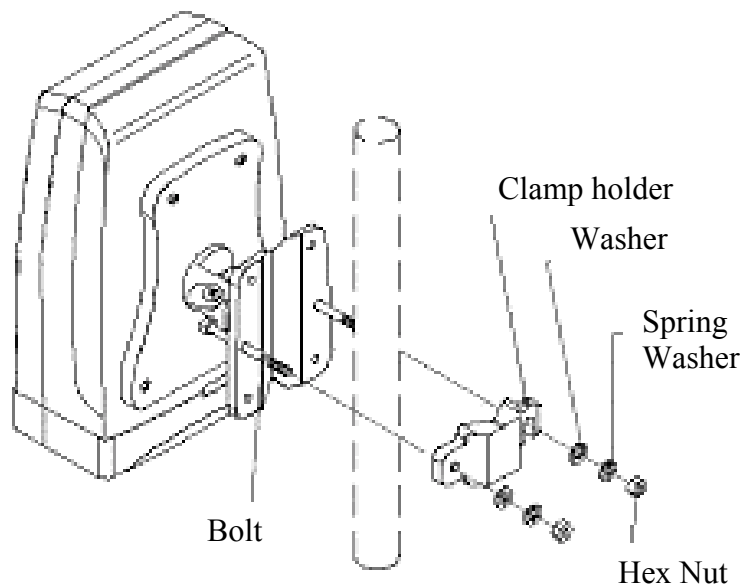

Figure 10-9: IDR pole mounting components

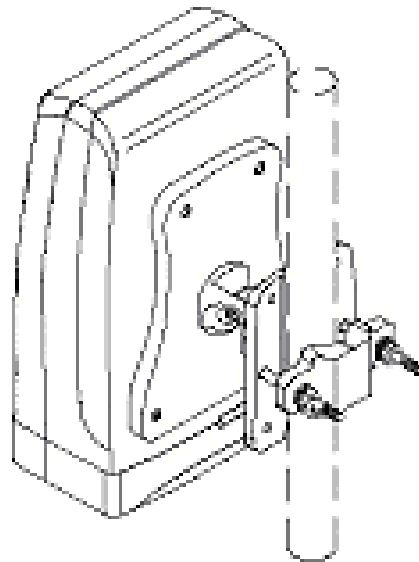

Figure 10-10: IDR secured to a pole

To set the correct IDR inclination:

1. Loosen the 2-off M4 socket head screws on the mounting bracket tilt-arm
2. Position the IDR at the desired angle.
3. Re-tighten the 2 off socket screws on the tilt arm.

10.3.2.3. Wall Mounting



Warning: Prior to drilling holes in a wall ensure that there are no hidden services such as electricity cables or water pipes. A stop must be used on the power drill to ensure that bored holes do not exceed 35 mm.

To mount the IDR on a wall:

1. Loosen the 2-off M4 socket head screws on the mounting bracket tilt-arm and remove the wall hanger.
2. Offer up the wall hanger to the wall and scribe through the mounting hole locations.
3. Drill holes to suit the type of wall fixing.
4. If required insert anchor plugs suited to the wall material.
5. Affix the wall hanger using 4-off screws suited to the anchor plugs and wall material.
6. Re-attach the IDR mounting bracket to the wall hanger. Finger tighten the screws.
7. Position the IDR at the desired inclination.
8. Re-tighten the screws to lock the IDR in position.

10.4. Connecting a Third-Party External Antenna

The IDR provides a TNC-type connector for connecting a third-party antenna to the IDR. This antenna can be placed on the subscriber's windowsill to provide better RF signal reception with the BSR.



Note: Airspan supplies unterminated cables for N-type connectors. Therefore, refer to the cable crimping procedures for N-type connectors detailed in Appendix B, "Cable Crimping".

- **Connector:** TNC-type male



Warning: Before connecting the external antenna, ensure that the IDR is NOT connected to the power source.

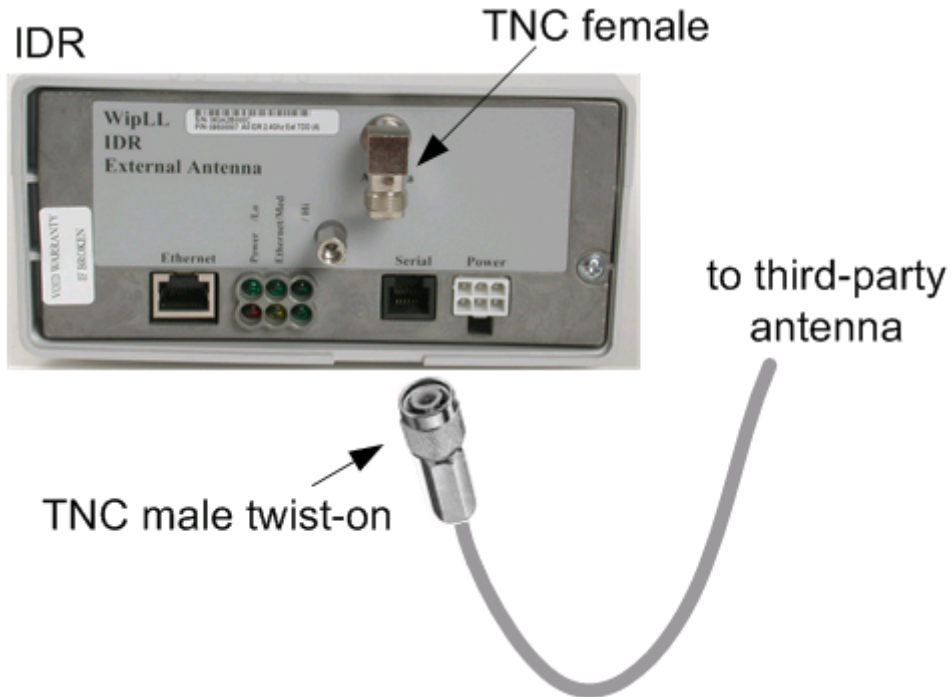

Figure 10-11: Connecting a third-party antenna



Warning: It is the responsibility of the person installing the WipLL system to ensure that when using the outdoor antenna kits in the United States (or where FCC rules apply), that only those antennas certified with the product are used. The use of any antenna other than those certified with the product is expressly forbidden in accordance with FCC rules CFR47 part 15.204. The installer should configure the output power level of antennas according to country regulations and per antenna type.

10.5. Connecting to an Ethernet Network

The IDR provides one Ethernet interface for the subscriber's Ethernet network. This port is located on the front panel, and labeled **Ethernet**.

■ **Connector:** 8-Pin RJ-45

■ **Cable:** CAT-5

■ **Connector pinouts:**

Pin	Function
1	Rx+
2	Rx-
3	Tx+
4	Not Connected
5	Not Connected
6	Tx-
7	Not connected
8	Not connected

To connect IDR to the subscriber's Ethernet network:

1. Attach the 8-pin RJ-45 connector, at one end of the cable, to the IDR's Ethernet port, labeled **Ethernet** (see Figure 10-12).
2. Attach the 8-pin RJ-45 connector, at the other end of the cable, to the PC's LAN port (see Figure 10-12).

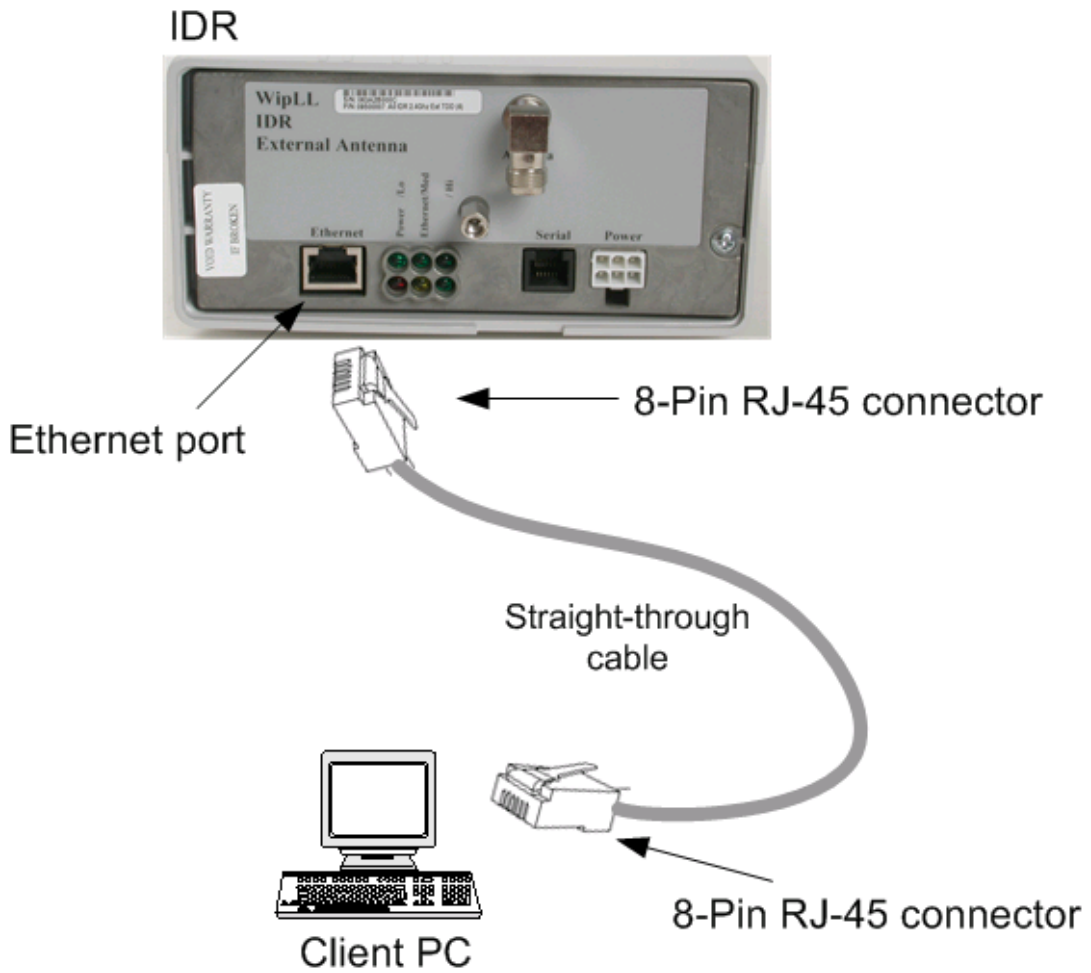

Figure 10-12: Connecting IDR to a client PC

10.5.1. Ethernet LED Indicator

The IDR provides one LED that indicates an Ethernet connection. This LED is labeled **Ethernet** and is located on the IDR's top panel.

Table 10-2: Description of Ethernet LEDs

LED	Color	Status	Indicates
Ethernet	Orange	On	Physical link between IDR and Ethernet network
		Off	No physical link between IDR and Ethernet network
		Blinking	Data is flowing through the Ethernet port

10.6. Positioning IDR for Optimum RF Reception

Once mounted to a wall, pole, or desk the IDR unit may be positioned to ensure the best RF signal communication with the BSR. The RF signal strength is indicated by three LEDs on the IDR chassis. The following table describes the RF signaling strength indicator LEDs.

Table 10-3: Description of RF signal strength LEDs

LED	Color	Function	Status	Description	
				Previous Releases	Release 4.2B
RSSI LEDs: LO , MED , and HI	Green	RSSI level	All LEDs On	$\text{RSSI} \geq -60 \text{ dBm}$	$\text{RSSI} \geq -60 \text{ dBm}$
			Two LEDs On	$-65 \text{ dBm} \leq \text{RSSI} \leq -61 \text{ dBm}$	$-70 \text{ dBm} \leq \text{RSSI} < -60 \text{ dBm}$
			One LED On	$-70 \text{ dBm} \leq \text{RSSI} \leq -66 \text{ dBm}$	$-80 \text{ dBm} \leq \text{RSSI} < -70 \text{ dBm}$
			One LED Blinking	$\text{RSSI} \leq -77 \text{ dBm}$	$-90 \text{ dBm} \leq \text{RSSI} < -80 \text{ dBm}$
			All LEDs Off	$-76 \text{ dBm} \leq \text{RSSI} \leq -71 \text{ dBm}$	$\text{RSSI} < -90 \text{ dBm}$

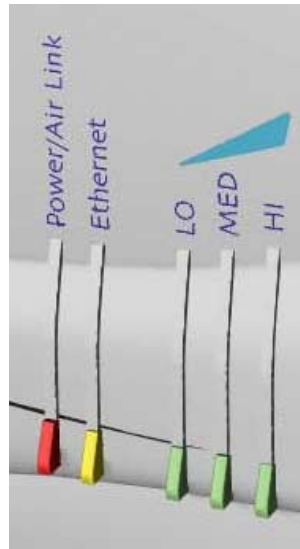

Figure 10-13: IDR LED indicators

To position the IDR for optimum RF signal:

- Position the IDR until all three RF signaling strength indicator LEDs are lit.

Refer to Section 10.3.2, “Wall and Pole Mounting” page 10-8 for details on adjusting IDR wall and pole mounting position.

For desk-top mounting, the IDR can be simply relocated to obtain the strongest signal.

10.7. Connecting to PC for Serial Configuration

To perform IDR initial configuration, you need to connect the IDR's RJ-11 port to the serial port of a PC running the WipLL network management application (i.e., WipConfig).

The IDR's RJ-11 port labeled **Serial**, located on the front panel, connects to the serial port of a PC via a cable with an RJ-11 connector on the one end, and a 9-Pin D-type connector on the other (i.e., a direct serial cable connection-DCC).

■ Connectors:

- 6-Pin RJ-11 male to 9-pin D-type female adapter
- 9-Pin D-type male to 9-Pin D-type female adapter

■ Cable:

- **Straight-through cable** with 6-Pin RJ-11 male on one end and 9-Pin D-type female on the other (connects between IDR and crossover cable)
- **Crossover cable** with 9-Pin D-type male on one end and 9-Pin D-type female on the other (connects straight-through cable to PC)

■ **Connector pinouts:**

Straight-through cable		Crossover cable		
6-Pin RJ-11		9-Pin D-type female	9-Pin D-type male	9-Pin D-type male
Pin	Function	Pin	Pin	Pin
1	Rx	2	4	3
2	Not connected	-	-	-
3	NC	-	-	-
4	NC	-	-	-
5	GND	5	1	5
6	Tx	3	3	2
		-	-	-
		-	-	-
		-	-	-

To connect the IDR to the WipLL management station (PC):

1. Connect the **6-Pin RJ-11** connector to the IDR's RJ-11 port (labeled **Serial**) located on the IDR's front panel (see Figure 10-14).
2. Connect the **9-Pin D-type female** connector, at the other end of the straight-through cable, to the **9-Pin D-type male** connector of the cross-over cable (see Figure 10-14).
3. Connect the **9-Pin D-type male** connector, at the other end of the cross-over cable, to the PC's serial port (see Figure 10-14).

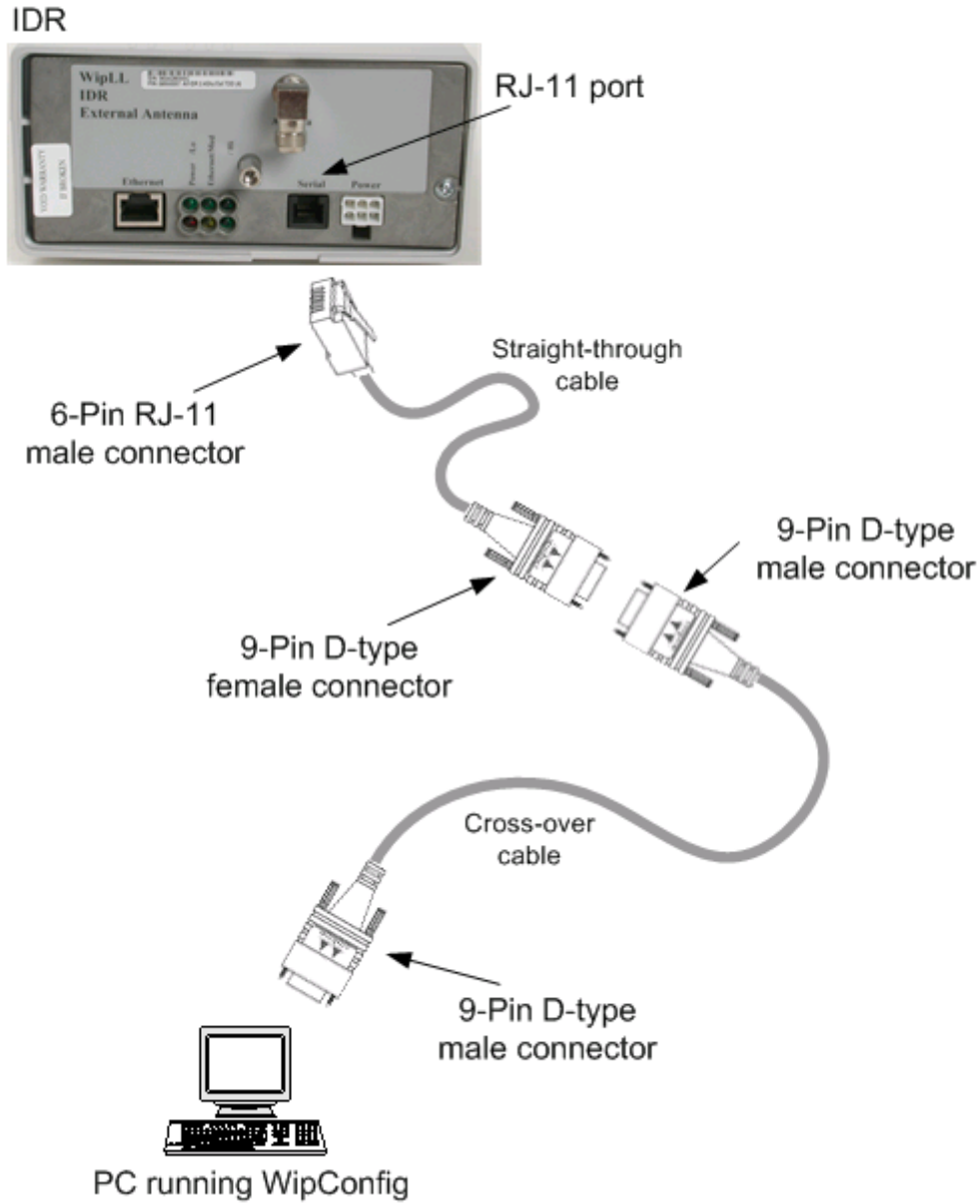

Figure 10-14: IDR-to-PC Serial Cable Connections

10.8. Connecting Power

The IDR is powered by an external power supply (*Triple Output External Adapter*). The IDR connects to the power adapter via the IDR's power port located on the IDR's front panel.

The following table lists the external power supply specifications:

Table 10-4: IDR power supply requirements

Power parameter	Units
Voltages	110-240 VAC
Frequency	50 to 60Hz
Maximum power consumption	Less than 15W



Warning: If you are using an external antenna, ensure that you connect the antenna before connecting the BSR to the power source.



Warning: Ensure that plugs fitted to mains power leads for subscriber premises equipment are compatible with AC mains sockets. Do not replace plugs on power leads to suit local requirements without first verifying earthing practice for the country and equipment in question.

Careful consideration must be given to issues including local wiring requirements, cable color-coding, and safety earthing and circuit protection requirements.



Warning: To avoid electrical or fire hazard, ensure that the data connections to the IDR are made prior to connecting the power supply. The AC mains must be capable of supplying at least 230 VAC

Prior to connecting to the power outlet, the following pre-connection inspection should be performed on power sockets:

- Power socket shall be visually inspected to ensure that no other equipment is connected to the power outlet.

- There is no physical sign of damage to the power outlet.
- There should not be any visible sign of water or dampness on or around the power outlet.
- The plug and socket assemblies are to be firmly secured.
- The power outlet shall be checked using a proprietary plug tester such as a ‘Martindale Ze’ type. Checks are required to verify the earth loop impedance value and the presence of phase, neutral and earth connections.
- **Connector:** 6-Pin power connector
- **Cable:** 3-core 0.7mm² type
- **Connector pinouts:**

Pin	Function
1	+6.5V
2	+5V
3	3.3V
4	GND
5	Not connected
6	Not connected

To connect the power:

1. Plug the AC power adapter’s **6-pin Molex** connector into the IDR’s power port labeled **Power** (see Figure 10-15).
2. Plug the **AC power plug female**, at the one end of the AC power cable, into the AC power adapter’s socket (see Figure 10-15).
3. Plug the **AC power plug male**, at the other end of the AC power cable, into the electrical outlet (see Figure 10-15).

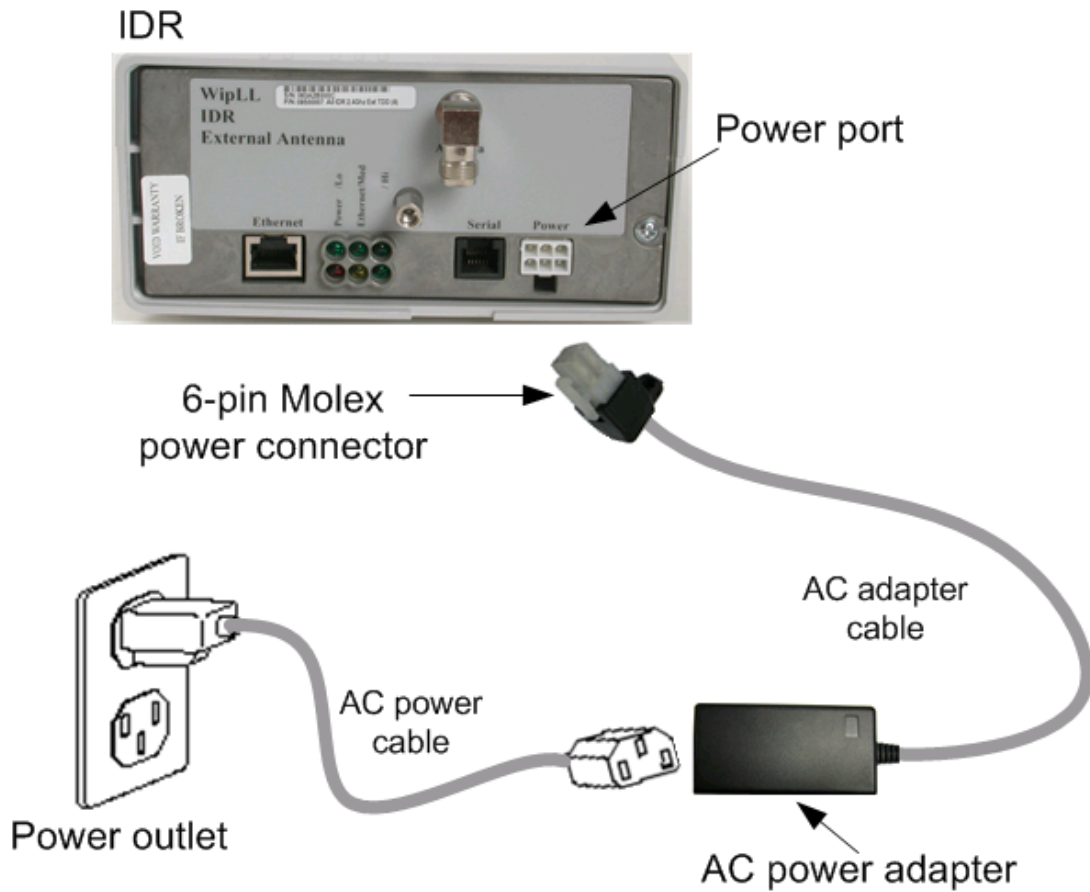

Figure 10-15: Connecting power to the IDR

10.8.1. Power LEDs

The IDA provides a power LED indicator, labeled **Power**, which indicates whether a power supply exists. The **Power** LED is located on the front panel of the IDR chassis.

Table 10-5: Description of Power LEDs

LED	Color	Status	Meaning
Power	Red	On	The SDA receives power supply
		Off	No power received



Glossary

AC	Alternating Current
BNC	Bayonet Neill Concelman (Connector type)
BSDU	Base Station Distribution Unit
BSPS	Base Station Power System
BSR	Base Station Radio
CEP	Common Earth Point
DC	Direct Current
DCC	Direct Serial Cable Connection
GPS	Global Positioning Satellite
HSP	Hop Synchronisation Process
HSPP	Hop Synchronisation Process Pulse
IDR	Indoor Data Radio
IP	Internet Protocol
LED	Light Emitting Diode
mA	Milliamperes
MCB	Miniature Circuit Breaker
Mbps	Mega Bits Per Second
Nm	Newton-metres
NMS	Network Management System
NOC	Network Operations Centre
PSTN	Public Switched Telephone Network
RJ	Registered Jack (modular connector)

SDA	Subscriber Data Adaptor
SME	Small and Medium Enterprises
SOHO	Small Office/Home Office
SPR	Subscriber Premises Radio
UPS	Un-interrupted Power Supply
UPVC	Unplasticized Poly-Vinyl Chloride
WAN	Wide Area Network
WipLL	Wireless internet protocol -Local Loop



Cable Crimping

This chapter describes the procedure for crimping cables for 15-Pin D-type and N-type connectors that are used in BSR/SPR-to-BSDU/SDA and BSR-to-GPS connections, respectively. The opposite ends of these cables are un-terminated, thereby providing length flexibility for connecting these WipLL units.

Crimping procedures are described for the following cable-connector terminations:

- **CAT-5e/15-Pin D-type** cable/connector terminations for SPR-to-SDA connections
- **Multipair Overall Shielded (22 AWG)/N-type** cable/connector terminations for GPS antenna connections.
- **GPS antenna connector**



Warning: Correct crimping of network cables is crucial for ensuring service integrity.

B.1. Crimping CAT-5e Cable for 15-Pin D-Type Connectors

This section describes the cable stripping and crimping of CAT-5e cables for 15-Pin D-type connectors used for BSR/SPR-to-BSDU/SDA connections.

Airspan recommends the "ITT Canon DB15" (code number 'DAW15P') sub-miniature type. This connector is an Insulation Displacement Connector (IDC) which crimps and secures the cable at the connection point.

Airspan recommends the following tools for stripping and crimping for 15-Pin D-type connectors:

- **Crimping tool**—hand-crimper code DW115394-1. The crimper is a cyclic crimper and will not release the cable until a full termination cycle has been completed. The tool automatically indexes to the next pin on completion of the terminating cycle.(See Figure B-1.)

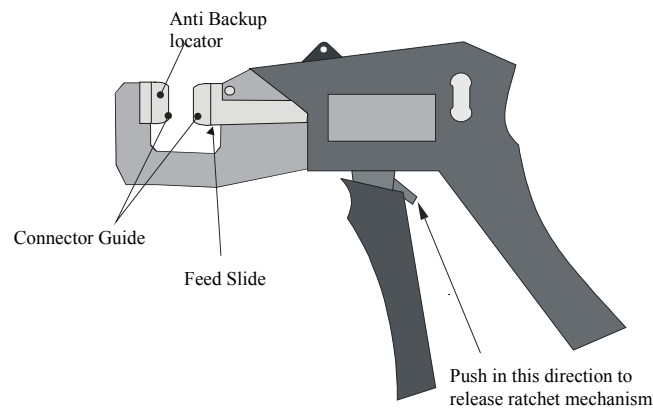

Figure B-1: Hand-Crimping Tool for 15-Pin D-Type Connector

The major features of the crimper are described in the following table:

Table B-1: Main features of crimping tool

Tool feature	Function
Terminating Head	Guides and supports the connector.
Wire Inserter	<ul style="list-style-type: none"> Cuts wire to be terminated. Forces conductors into 2 slotted beams of the contact.
Anti-backup locator	Prevents connector from moving out of position for accurate termination.
Feed Slide	Automatically advances the connector after each termination.
Adjuster	Provides wire insertion depth adjustment
Cam handle	Activates the termination mechanism inside the head.
Ratchet Pawl	Releases the cam handle before it is fully closed should a problem occur during termination operation.

- **Stripping tool**—three-way stripping tool—*IPAC10349AKM* (see Figure B-2)

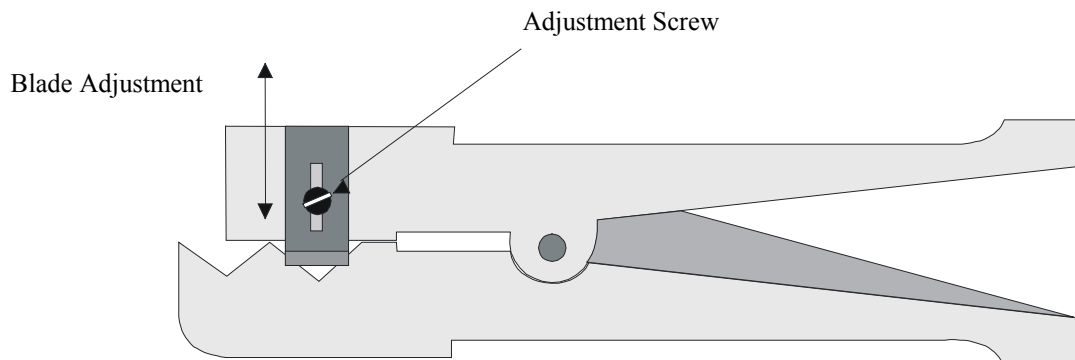

Figure B-2: Stripping Tool 1PAC10349 AKM

Cable crimping is performed in two stages:

1. Stripping the cable
2. Crimping the cable

B.1.1. Stripping the Cable

Before crimping the cables, you need to strip 50 mm of the cable.

Before using the tool, ensure that the tool is correctly adjusted. Correct adjustment is obtained when the blade cuts the outer insulation without damage to the insulation of inner conductors.

To strip the cable:

1. Cut the cable to length using cable shears (Airspan code 1PAC10333AKJ).
2. Strip 50 mm of the sheathing using stripping tool.
3. Insert the cable in the jaws of the cutting tool by squeezing the handles together.
4. Rotate 10 times, release the tool, and remove the cable and insulation.

5. Use a steel rule (1PAC10042AAV) to verify the stripped dimension.
6. Inspect the cut for evidence of damage, i.e. has the braid been cut? If so cut off cable and reset tool.

B.1.2. Crimping the Cable

Once you have stripped 50 mm of the cable, you can begin crimping the cable to the 15-Pin D-type connector.



Note: For 15-Pin D-type connector pinouts, see the relevant chapter on the specific WipLL equipment.

To crimp the cable:

1. Insert the 15-Pin D-type connector into the left slot of the crimper until the desired connector pin position aligns with the slot.
2. Insert the wire into the left side of the crimper slot until the end enters the hole.
3. Adjust the desired length of the wire.
4. Centre the wire in the slot.
5. Squeeze the crimper handles until the wire inserter bottoms out.
6. Release the crimper handles—the inserter retracts and the connector advances to the next pin position.
7. Repeat the above until all pin contacts of the row have been terminated.

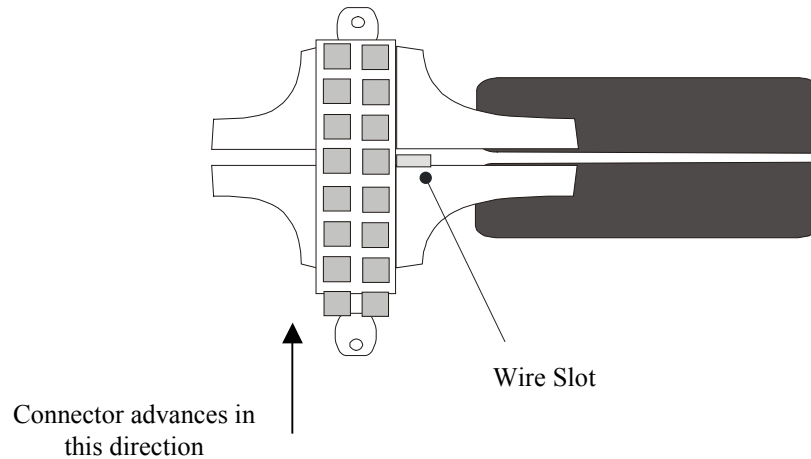

Figure B-3: Crimping tool

8. When finished, remove the connector from the right side of connector slot.



Note: The connector must be inserted into the crimper from the left hand side only.

Should the connector jam in the terminating position, excessive force must not be used: the spigot between the tool handles should be used to release the ratchet mechanism.

The crimper handle will not allow release until a full termination cycle of the connector has been completed.

B.1.3. Inspecting the Crimped Connector

Each crimped connector is to be tested that it has been correctly crimped:

- Ensure that the wire extends beyond the front pin contact slot by a minimum of 0.5 mm
- Ensure that the two legs of the insulation crimp barrel are closed to secure the insulation of the wire



Note: The purpose of the barrel is to prevent the wire from being lifted from the contact. It is not necessary to have the barrel wrapped tightly around the insulation.

- Ensure that the contact cavity has not been deformed
- Confirm integrity by holding the connector in one hand and pulling lightly on the cable.

Figure B-4 shows points to be observed during quality inspection.

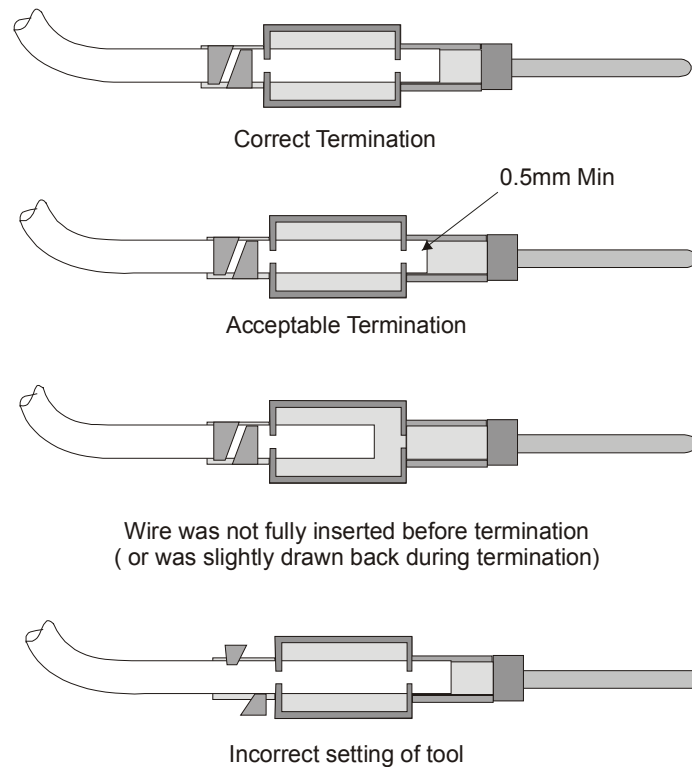

Figure B-4: Crimp Connector Inspection

B.1.4. Housing the Connector

For outdoor cable installations, the connector is to be protected in a waterproof housing assembly as shown in Figure B-5.



Note: The housing, cable seal, and clamping nut are to be slid onto the cable prior to crimping the connector in place.

To assemble the connector in a waterproof housing:

1. Insert the connector into the waterproof housing ensuring that a "click" is heard.
2. Screw the cable seal into place ensuring that the cable outer sheath is inside the connector body.
3. Secure the cable in place with the lock nut.

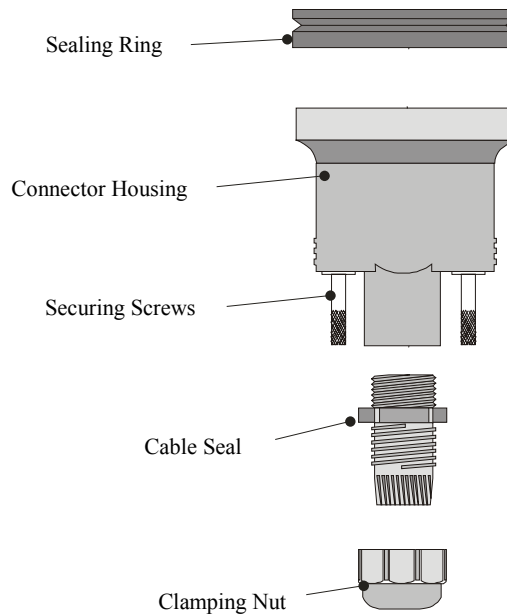

Figure B-5: Waterproof Connector housing assembly

For indoor cabling applications it is not necessary to use a waterproof housing for the connector.

To assemble the un-housed connector:

1. Insert the connector terminal block into the connector body.
2. Secure the cable onto the connector body using the cable clamp. Ensure that the cable outer sheath is within the connector body.
3. Snap the top section of the connector body into place.
4. Ensure that the connector is secure within the housing by applying a light pull on the cable.

B.2. Crimping N-type Connectors

This section describes the cable stripping and crimping **Multipair Overall Shielded (22 AWG)** cables for **N-type** connectors used for BSR/SPR connections to external antennas.

Airspan recommends using the following tools for crimping of N-type connectors:

- **Crimp tool:** Erma 29020 with die set 29207.
- **Stripping tool:** Maxi Corex, fitted with the 9.0 to 11.5mm cable clamp (blue) and the 9.5 to 3.2 blade cassette (green).

B.2.1. Stripping the Cable

To strip the cable:

1. The first cut should be set to cut through the outer sheath, braid and dielectric. Scoring of the centre conductor should not occur.
2. The second cut should be set to cut through the outer sheath and the braid. Important attention must be paid to the dielectric where it meets the braid. It is preferable that no cutting of the dielectric takes place, however, because of the construction of cables and tolerance build up there may be occasion where a slight cutting of the dielectric is unavoidable. This must be kept to an absolute minimum. This has been termed the compromise cut and is acceptable practice.
3. The final cut should be set to cut through the outer sheath only. Scoring of the braid should not occur.
4. All sections of the stripped Ethernet cable should be easily removed if the blade settings are correct. To adjust the blade settings use the allen key provided and apply it to the grub screws at the back of the stripping tool. Clockwise will increase blade depth, anti-clockwise will reduce blade depth.
5. Set stripping tool slide mechanism to 5.
6. Place the cable into the stripping tool with approximately 12 mm protruding from the end of the tool.

7. Clamp the tool around the cable and lock in position.
8. Holding the cable in the left hand and stripping tool in the right hand (index finger through finger hole) rotate tool in a clockwise direction for 10 turns.
9. Move slide mechanism to number 3.
10. Rotate tool in a clockwise direction for 10 turns.
11. Move slide mechanism to number 1.
12. Rotate tool in a clockwise direction for 10 turns.
13. Unlock the tool to remove cable then lock shut. Always keep the stripping tool locked shut when not in use. Take care when handling the blade insert.
14. Twist off stripped cable sections.

B.2.2. Assembling the Connector

Once you have stripped the cable, you can house the cable:

To house the cable:

1. Fit an insulating boot if required, over the cable, cutting enough of the pointed end to enable the cable to go through the resulting hole with a fairly tight grip. Push ferrule over the stripped section of cable.
2. Rotate the centre conductor in relation to the cable to splay the braid and any foil from the dielectric, which will allow the later correct fitting of the connector body (over the dielectric). See Figure B-6. Take care not to damage the braid.

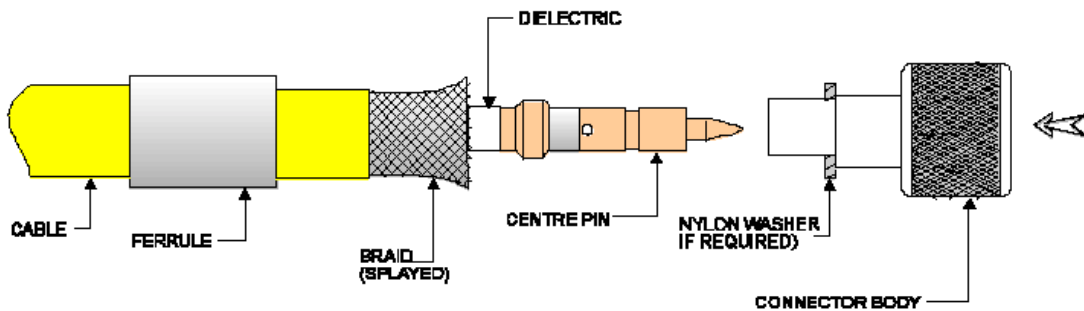

Figure B-6: Rotating conductor

3. Trim the centre conductor back to 5.5 mm from the end of the dielectric. Use the cable shears provided and not the side cutters.
4. Fit centre pin on to the centre conductor. The centre conductor should be seen through the inspection hole (see Figure B-7). Ensure that the shoulder of the pin is butted up to the cable's dielectric.

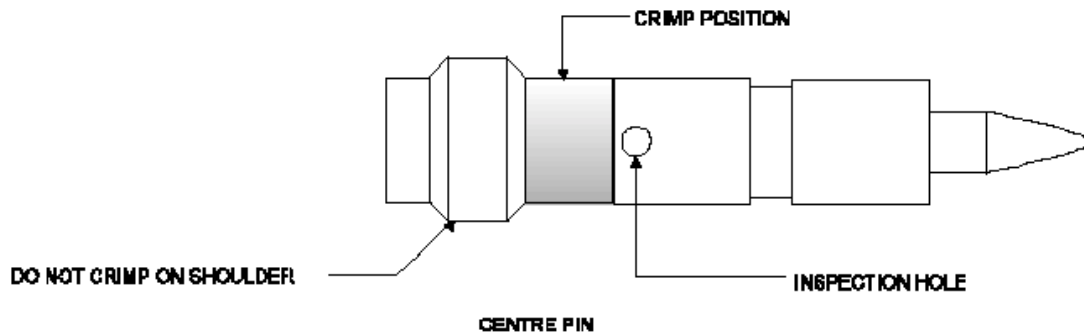

Figure B-7: Fitting center pin onto center conductor

B.2.3. Crimping

To crimp the GPS connector:

1. Using an Erma tool and 29207 die, small aperture, crimp centre pin to centre conductor. The crimp section should be just below the inspection hole (see Figure B-7). Do not crimp the shouldered section as it will cause flashing.
2. Fit the connector body over the centre pin and between the braid and dielectric (see Figure B-6). Do not trap any of the braid between the dielectric and back face of the connector body. If the connector is supplied with a nylon washer, fit this to the rear of the connector before application to the cable.
3. Push the connector body firmly home. The centre pin should align with the end of the internal diameter of the connector body.
4. Push the ferrule up to the end of the cable, covering the braid. There should be no braid showing between the end of the ferrule and the connector body. Rotating the ferrule may rectify this, if not trim the braid slightly to suit.

5. Crimp the ferrule using the large aperture of the 29207 die. When offering up the tool the die should be positioned so as it aligns with the braid and not the outer sheath of the cable.
6. Connectors with nylon washers, the crimp is to be made with the dies held firmly against the washers face.

B.3. Crimping GPS Cable Connectors

Airspan recommends the following tools for crimping for N-type connectors:

- **Crimping tool**—*Daniels AFM8* (M22520/2-01).

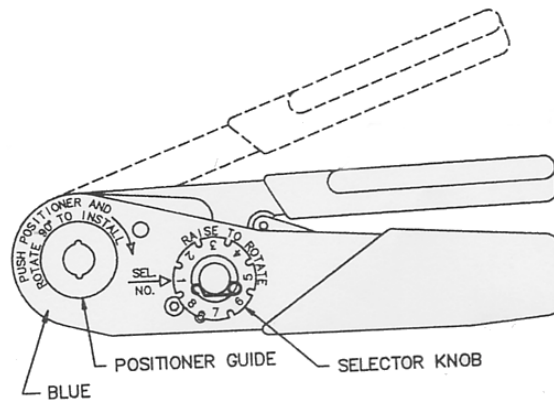

Figure B-8: Crimping tool – Daniels AFM8

Once you have housed the stripped cable, you can now crimp the cable to an N-type connector.



Note: The crimper cannot be opened without completing the cycle.

To crimp the cable:

1. Ensure that the crimper is in the open position.
2. Remove safety clip from positioner guide.
3. Select the Positioner for contact to be crimped.
4. Insert the Positioner into the positioner guide and turn it 90 degrees until bayonet pins lock.
5. Raise and rotate the Selector knob until the number indicated on data plate for cable size to be crimped is in line with **Sel. No.** arrow.

6. Insert the contact and prepared cable into the indenter opening from the side opposite the Positioner.
7. Squeeze crimper handles together until the ratchet releases. The handle will return to the open position.
8. Remove crimped contact and cable.



Technical Specifications

This appendix lists the technical specifications for the following WipLL units:

- WipLL Base Station equipment:
 - Base Station Radio (BSR)
 - Point-to-Point Radio (PPR)
 - Base Station Distribution Unit (BSDU)
 - Base Station Power Supply (BSPS)
 - GPS antenna
- WipLL Customer premises equipment:
 - Subscriber Premises Radio (SPR)
 - Subscriber Data Adapter (SDA)
 - SDA-1
 - SDA-4H
 - SDA-4S models
 - Indoor Data Radio (IDR)

C.1. Base Station WipLL Equipment

The following sub-sections list the specifications of the following WipLL Base Station equipment:

- Base Station Radio (BSR)
- Point-to-Point Radio (PPR)
- Base Station Distribution Unit (BSDU)
- Base Station Power Supply (BSPS)

C.1.1. Base Station Radio (BSR)

Table C-1: BSR and MAC Specifications

Parameter	Value	Comment
Operating frequency range	<ul style="list-style-type: none"> • 2.4 GHz • 3.x GHz, MMDS, 2.8 GHz • 5.8 GHz • 900 MHz 	<ul style="list-style-type: none"> • ISM band • Licensed band • Unlicensed band • Unlicensed band *Other ranges available for trial
Spectrum spreading method	Frequency hopping	Per ETSI EN301 253
Duplex method	<ul style="list-style-type: none"> • Time Division Duplex (TDD) - 2.4 GHz, 2.8 GHz, 3.x GHz, MMDS, 900 MHz, and 5.8 GHz • Frequency Division Duplex (FDD) - 3.x GHz 	
Transmit bit rates	Up to 4 Mbps	BER and distance dependent
Channel spacing	1 MHz	For 3.5 GHz the channel spacing can be 1 MHz or 1.75 MHz
Output power from the BSR	Up to 27 dBm, configurable at 2.4 GHz	Depending on local regulations, maximum output power can be configured at the factory
Modulation method	8-level CPFSK	
Channel access method	PPMA / Adaptive TDMA	
Protocol efficiency	Up to 80%	For large data packets
Number of SPR/IDR per BSR	Up to 126	

Table C-2: BSR EMC and Radio Standards Compliance

Parameter	Value
Radio Standards Compliance	<ul style="list-style-type: none"> • ETSI EN 300 328-1 • ETSI EN 301 253 • FCC part 15 • RSS139 • Telec
EMC	<ul style="list-style-type: none"> • ETSI ETS 300 826 • ETSI EN 300 385 • ETSI EN 300 386-2 • ETSI ETS 300 132-2 • FCC part 15

Table C-3: BSR Agency Certification

Parameter	Value
Emissions / Immunity	EN 300 339 EN 300 386-2 ETS 300 328
Safety	EN / IEC 60950
Environmental	ETS 300 019-2-x

Table C-4: BSR Network Specifications

Parameter	Value	Comment
Filtering Rate	10,500 frames/sec	At 64 byte packets
Forwarding Rate	1,300 frames/sec	At 64 byte packets
Routing table length	200 networks, including subnets	

Table C-5: BSR Power Requirements

Parameter	Value	Comment
Voltage	48 VDC nominal	Voltage is received from the BSDU
• Minimum:	• 30 VDC	
• Maximum:	• 55 VDC	
Maximum Amperes:	500 mA	

Table C-6: BSR Environmental Conditions

Parameter	Value	Comment
Operating temperature of outdoor units (BSR and SPR)	-30°C to +60°C	Optional range of -40°C to +70°C
Storage temperature	-40°C to +80°C	

Table C-7: BSR Network Interface

Parameter	Value	Comment
Ethernet Network	UTP EIA/TIA	Category 5
Standards Compliance	ANSI/IEEE 802.3 and ISO/IEC 8802-3 10Base-T compliant	
Serial Port	RS-232	

Table C-8: BSR Physical Dimensions

Parameter	Value	Comment
Height	400 mm	Excluding mounting kit
Width	317 mm	
Depth	65.5 mm	
Weight	4.7 kg	

C.1.2. Point-to-Point Radio (PPR)

Table C-9: PPR Radio Specifications

Parameter	Value
Operating frequency bands	<ul style="list-style-type: none"> • 2,400 to 2,500 MHz • 3,400 to 3,800 MHz • 5,725 to 5,875 MHz
Duplex method	<ul style="list-style-type: none"> • Time Division Duplex (TDD) for all bands • Frequency Division Duplex (FDD) for 3.4 to 3.8 GHz
Radio Technology	FH-CDMA
Multiple Access Method	PPMA
Output power	27 dBm
Antenna type (built-in)	<ul style="list-style-type: none"> • PPR • SPR
	<ul style="list-style-type: none"> • 18 dBi / 15 dBi • 18 dBi / 15 dBi
Sub-Channel Spacing	1 MHz
Modulation	Multilevel (2, 4, or 8) CPFSK
Receiver Sensitivity (BER 1E-6 at 2/4/8 FSK)	-90/ -83/ -75 dBm
Throughput	Up to 4 Mbps per PPR-SPR link
Radio Standards Compliance	<ul style="list-style-type: none"> • ETSI EN 300 328-1 • ETSI EN 301 253 • FCC part 15 • RSS139 • Telec
EMC	<ul style="list-style-type: none"> • ETSI ETS 300 826 • ETSI EN 300 385 • ETSI EN 300 386-2 • ETSI ETS 300 132-2 • FCC part 15

C.1.3. Base Station Distribution Unit (BSDU)

Table C-10: BSDU Network Specifications

Parameter	Value
Filtering Rate	105,000 Frames / sec
Forwarding Rate	62,500 Frames / sec

Table C-11: BSDU Power Requirements

Parameter	Value
Voltage	48VDC nominal
Power consumption	Maximum 300W (including the feeding of 6 × BSRs)

Table C-12: BSDU Environmental Conditions

Parameter	Value
Operating Temperature	0°C to +50°C
Storage Temperature	-40°C to +80°C

Table C-13: BSDU Network Interface

Parameter	Value	Comment
Ethernet Network	100/10Base-T: UTP EIA/TIA	Category 5
Standards Compliance	ANSI/IEEE 802.3, ISO/IEC 8802-3 10/100 Base-T compliant	
Serial Port	RS-232	

Table C-14: BSDU Physical Dimensions

Parameter	Value
Height	4.32 cm
Width	48.26 cm
Depth	22.86 cm
Weight	2.9 kg

C.1.4. Base Station Power Supply (BSPS)

Table C-15: BSPS Rectifier Specifications

	Parameter	Value
Input	Voltage	90VAC to 270VAC
	Current (nominal)	3.2A @ 230V / 4.3A @ 115V
	Frequency	47Hz to 63Hz
	Power factor (nominal line/load)	Greater or equal to 0.993
Output	Voltage (default)	53.5VDC
	Regulation (line & load)	±0.4%
	Adjustable range	47 to 58 VDC
	Current	12A @ 54V
	Ripple & noise	50mVp-p
	Efficiency (nominal load)	85% @ 230V / 82% @ 115V
	Overload current	<12A
	Over-voltage protection	60 VDC
	Over-temperature protection (measured on case, upper panel corner)	<ul style="list-style-type: none"> • 80±5°C rectifier stops • 72±5°C rectifier recovers
	Walk-in time	< 0.5 sec
	Hold-up time	40 ms
General	Withstand voltage (1 min)	<ul style="list-style-type: none"> • 4230VDC INPUT/OUTPUT • 2120VDC INPUT/GND • 1700VDC OUTPUT/GND
	Working temperature	-10 to 45°C
	Storage temperature	-50 to 80°C
	Dimensions (mm)	235 x 150 x 50 (L x W x H)
	Weight	1100g
	EMC	Refer to system specifications
	Safety	According to: IEC950

Table C-16: BSPS DC Distribution Specifications

	Parameter	Value
Input	Voltage	90VAC to 270VAC
	Current (at full load) N =Number of rectifier modules	<ul style="list-style-type: none"> • N*3.2A @ 230V • N*4.3A @ 115V
	Frequency	47 Hz to 63 Hz
	Power factor (at full load)	Greater or equal to 0.993
	Voltage (programmable)	42 to 60VDC \pm 0.5VDC
Output	Default float and boost voltage	54 and 57VDC respectively
	Regulation (line, load, sharing)	\pm 1%
	Current	N*12A (48A max.)
	Psophometric noise	-52 dBm (over 600 &)
	Ripple & noise	50mVp-p
	Efficiency (nominal load)	85% @ 230V / 82% @ 115V
	Overload current	< N*12A
	Over-voltage protection	60VDC
	Walk-in time	< 1 sec
	Hold-up time	40 ms
	Output current indication	10 LED's bar-graph
	Active current sharing	\pm 10% accuracy at full load
	Withstand voltage (1 min)	2120VDC INPUT/GND
General	Working temperature	-10 , 45°C
	Storage temperature	-50 , 80°C
	Dimensions (19" X 3U)	Depth is 320mm W/O terminals, 360mm with terminals
	Weight	13 kg (main unit + 3 rectifiers)
	RS232 Communication	9600 bps, no-parity, 1 stop-bit

	Parameter	Value
	EMC	According to: <ul style="list-style-type: none"> • EN300-386-2 SUB 7.2.3 • EN55022 class B • IEC1000-4-2 • IEC1000-4-3 • IEC1000-4-4 • IEC1000-4-5 • IEC1000-4-6 • IEC1000-4-11 • IEC1000-3-2 • IEC1000-3-3
	Safety	According to: IEC950
	Maximum current withstand	2x70A
LVL (optional)	Trip voltage level	Disconnect default: 43± 0.5 VDC, user programmable Re-connect: with AC recovery

C.1.5. GPS antenna

Table C-17: SPR Power Requirements

Parameter	Value	Comment
Voltage Input	36 VDC	Supplied by WipLL's BSDU
Consumption	1.8W	

Table C-18: Environmental Considerations

Parameter	Value	Comment
Operating temperature	-30°C to +75°C	

Table C-19: GPS General

Parameter	Value	Comment
Input	DGPS (Differential GPS)	
Output	1 pulse per second	
Standards Compliance	MIL-STD 810E	
Interface standard	RS-422	

Table C-20: GPS Dimensions

Parameter	Value	Comment
Diameter	115 mm	
Height	90 mm	

C.2. Customer Premises WipLL Equipment

The following sub-sections list the specifications of the following WipLL CPE equipment:

- Subscriber Premises Radio (SPR)
- Subscriber Data Adapter (SDA)
- Indoor Data Radio (IDR)

C.2.1. Subscriber Premises Radio (SPR)

Table C-21: SPR and MAC Specifications

Parameter	Value	Comment
Operating frequency	<ul style="list-style-type: none"> • 2.4 GHz • 3.x GHz, 2.8 GHz, MMDS • 5.8 GHz 	<ul style="list-style-type: none"> • ISM band • Licensed band • Unlicensed band
Spectrum spreading method	Frequency hopping	Per ETSI EN 301 253
Duplexing Method	<ul style="list-style-type: none"> • Time Division Duplex (TDD) 2.4 GHz, 2.8 GHz, MMDS, 3.x GHz, and 5.8 GHz • Frequency Division Duplex (FDD) 3.x GHz 	
Transmit Bit Rates	Up to 4 Mbps	BER and distance dependent
Channel spacing	1 MHz	
Output power from the radio	Up to 27 dBm, configurable at 2.4 GHz	Depending on local regulations. Maximum power output can be set at the factory.
Modulation method	8 level CPFSK	
Channel access method	PPMA / Adaptive TDMA	
Protocol efficiency	Up to 80%	For large data packets

Table C-22: SPR EMC and Radio Standards Compliance

Parameter	Value
Radio Standards Compliance	<ul style="list-style-type: none"> • ETSI EN 300 328-1 • ETSI EN 301 253 • FCC part 15 • RSS139 • Telec
EMC	<ul style="list-style-type: none"> • ETSI ETS 300 826 • ETSI EN 300 385 • ETSI EN 300 386-2 • ETSI ETS 300 132-2 • FCC part 15

Table C-23: SPR Agency Certification

Parameter	Value	Comment
Emissions / Immunity	EN 300 339, EN 300 386-2, ETS 300 328	
Safety	EN/IEC 60950	
Environmental	ETS 300 019-2-x	

Table C-24: SPR Network Specifications

Parameter	Value	Comment
Filtering rate	10,500 frames / sec	At 64 bytes
Forwarding rate	1,300 frames / sec	At 64 bytes
Routing table length	16	

Table C-25: SPR Power Requirements

Parameter	Value	Comment
<ul style="list-style-type: none"> • Voltage • Minimum • Maximum 	<ul style="list-style-type: none"> • 48 VDC nominal • 30 VDC • 55 VDC 	Power supplied from the SDA
Consumption	Maximum	500 mA

Table C-26: Environmental Considerations

Parameter	Value
Operating temperature	-30°C to +60°C
Storage temperature	-40°C to +80°C

Table C-27: Network Interface

Parameter	Value	Comment
Ethernet Network	UTP EIA / TIA	Category 5
Standards Compliance	ANSI/IEEE 802.3 and ISO/IEC 8802-3; 10BaseT compliant	
Serial Port	RS-232	

Table C-28: SPR Physical Dimensions (w/o High Gain Antenna)

Parameter	Value	Comment
Height	311 mm (12.24 inches)	Excluding mounting kit
Width	244 mm (9.6 inches)	
Depth	65.5 mm (2.57 inches)	
Weight	2.5 kg	

Table C-29: SPR Physical Dimensions (with High Gain Antenna)

Parameter	Value	Comment
Height	400 mm (15.74 inches)	Excluding mounting kit
Width	317 mm (12.48 inches)	
Depth	65.5 mm (2.57 inches)	
Weight	4.7 kg	



Note: The SPR cable and connector are the same as the BSR.

C.2.2. Subscriber Data Adapter (SDA)

C.2.2.1. SDA-1

Table C-30: SDA-1 Physical Dimensions

Parameter	Value
Height	200 mm
Width	150 mm
Depth	40 mm
Weight	47 kg

Table C-31: SDA Power Requirements

Parameter	Value
Output Voltage	-48VDC nominal
Power supply	110-240 VAC, 50/60Hz, 0.3-0.7A

Table C-32: SDA-1 Environmental Considerations

Parameter	Value
Operating temperature	0°C to +50°C

Table C-33: SDA-1 Network Interfaces

Parameter	Value
Data from SPR/BSR	DB15
Ethernet	RJ45 socket for a PC interface
Power	AC power connector

C.2.2.2. SDA-4H

Table C-34: SDA-4H Physical Dimensions

Parameter	Value
Height	200mm
Width	150mm
Depth	40mm
Weight	53 kg

Table C-35: SDA-4H Power Requirements

Parameter	Value
Output Voltage	-48VDC nominal
Power supply	110-240 VAC, 50/60Hz, 0.3-0.7A

Table C-36: SDA-4H Environmental Considerations

Parameter	Value
Operating temperature	0°C to +50°C

Table C-37: SDA-4H Network Interfaces

Parameter	Value
Data from SPR/BSR	DB15
Ethernet	Three RJ45 socket for a PC interface; one RJ-45 for cross over connection
Power	AC power connector

C.2.2.3. SDA-4S Models

Table C-38: SDA-4S Physical Dimensions

Parameter	Value
Height	200 mm (7.87 inches)
Width	150 mm (5.9 inches)
Depth	40 mm (1.57 inches)
Weight	53 kg

Table C-39: SDA-4S Power Requirements

Parameter	Value
Output Voltage	-48VDC nominal
Power supply	110-240 VAC, 50/60 Hz, 0.3-0.7A

Table C-40: SDA-4S Environmental Considerations

Parameter	Value
Operating temperature	0°C to +50°C

Table C-41: SDA-4S Network Interfaces

Parameter	Value
Data from SPR/BSR	15-pin D-type
Ethernet	Four 8-pin RJ-45 10/100BaseT sockets for PC interface. These ports support 10/100 Mbps Autosensing (Autonegotiation), and MDI/MDI-X automatic crossover
Power	AC power connector

C.2.3. Indoor Data Radio (IDR)

Table C-42: IDR Radio and MAC Specifications

Parameter	Value	Comment
Operating frequency	<ul style="list-style-type: none"> • 2.4 GHz • 3.45 GHz • 3.5 GHz • 900 MHz 	
Spectrum spreading method	Frequency hopping	(Per ETSI ETS 300 328) ARIB-STD-T66
Duplex Method	<ul style="list-style-type: none"> • Time Division Duplex (TDD) at 2.4 GHz and 900 MHz • Frequency Division Duplex (FDD) at 3.5 GHz and 3.45 GHz 	
Transmit Bit Rates	Up to 4 Mbps	Depending on BER
Channel spacing	1 MHz	
Output power from the radio	Up to 27 dBm, configurable at 2.4 GHz	Depending on local regulations. Maximum power output can be set at the factory.
Channel access method	PPMA	
Protocol efficiency	Up to 80%	At BER = 10^{-5} , depending on the application

Table C-43: IDR EMC and Radio Standards Compliance

Parameter	Value
Radio Standards Compliance	<ul style="list-style-type: none"> • ETSI EN 300 328-1 • ETSI EN 301 253 • FCC part 15 • RSS139 • Telec
EMC	<ul style="list-style-type: none"> • ETSI ETS 300 826 • ETSI EN 300 385 • ETSI EN 300 386-2 • ETSI ETS 300 132-2 • FCC part 15

Table C-44: IDR Agency Certification

Parameter	Value
Emissions / Immunity	<ul style="list-style-type: none"> • VCCI Class A • ARIB-STD-T66 • ETSI 300 386-2
Safety	EN/IEC 60950
Environmental	ETS 300 019-2-x

Table C-45: IDR Network Specifications

Parameter	Value	Comment
Filtering rate	10,500 frames/sec	At 64 bytes
Forwarding rate	1,300 frames/sec	At 64 bytes

Table C-46: IDR Power Requirements

Parameter	Value
External Power Supply Voltage	<ul style="list-style-type: none"> • Minimum: 100 VAC • Maximum: 240VAC
Operating Frequency Range	50 to 60 Hz
Maximum Power consumption	Less than 15W

Table C-47: IDR Environmental Considerations

Parameter	Value	Comment
Operating temperature	0-50°C	
Operating Humidity	+30C° 93%	Maximum humidity
Storage temperature	-40 – 70°C	

Table C-48: IDR Network Interface

Parameter	Value	Comment
Ethernet Network	UTP EIA / TIA	Category 5
Standards Compliance	ANSI/IEEE 802.3 and ISO/IEC 8802-3 10Base-T compliant	
Serial Port	RJ-11	

Table C-49: IDR Physical Dimensions

Parameter	Value	Comment
Weight	1,430 g	
Dimensions (H x W x D)	<ul style="list-style-type: none"> • 155 mm (6.1 inches) x 233 mm (9.17 inches) x 74.5 mm (2.93 inches) • 120.5 mm (4.74 inches) x 61mm (2.4 inches) x 35 mm (1.37 inches) 	<ul style="list-style-type: none"> • IDR with built-in antenna • IDR with an external antenna <p>Note: Dimensions exclude the external power adapter.</p>

Table C-8: IDR Pole Mounting Dimensions

Parameter	Value
Minimum pole diameter	35 mm (1.37 inches)
Maximum pole diameter	50 mm (1.97 inches)



Summary of Connector Pinouts

This appendix provides a summary of the connector pinouts for the WipLL devices.

D.1. BSR/SPR-to-BSDU/SDA CAT 5 Connector Pinouts

Table D-1 describes the 15-pin D-type connector pinouts for the CAT 5 cable that connects the BSR's/SPR's 15-pin D-type port to the BSDU's/SDA's 15-pin D-type port.

Table D-1: 15-pin D-type to 15-pin D-type connector pinouts

15-pin D-type male	BSR/SPR		Wire color	Wire pair	BSDU/SDA	
	Pin	Function			Pin	Function
	1	+48 VDC	Blue / white	1	1	+48 VDC
	2	-48 VDC	Blue		2	-48 VDC
	3	Tx+	Orange / white	2	3	Rx+
	4	Tx-	Orange		4	Rx-
	5	Rx+	Green / white	3	5	Tx+
	6	Rx-	Green		6	Tx-
	7	Sync.+	Brown / white	4	7	Sync.+
	8	Sync.-	Brown		8	Sync.-

**Notes:**

- Pins 9 through 15 of the 15-pin D-type connector are not used.
- The wire color-coding described in the table is WipLL's standard for wire color-coding. However, if you implement your company's wire color-coding scheme, ensure that the wires are paired and twisted according to the pin functions listed in Table D-1 (e.g., Rx+ with Rx-).

WipLL uses the following wire color-coding standards for CAT 5 cables with 15-pin D-type to 15-pin D-type connectors on either ends (8 wires used):









	Pin	Straight-through	Pin	
+48 VDC	1		1	+48VDC
-48 VDC	2		2	-48VDC
Tx+	3		3	Rx+
Tx-	4		4	Rx-
Rx+	5		5	Tx+
Rx-	6		6	Tx-
	7		7	
	8		8	

Figure D-1: WipLL wire color-coding for 15-pin D-type connectors



Note: The wires are twisted together in pairs, for example, blue/white with blue, and orange/white with orange. This prevents electrical interference between the transmitter pins. For example, pin 3 (Tx+; orange / white) is paired and twisted with pin 4 (Tx-; orange).

D.2. SPR Serial Connector Pinouts

For BSR and SPR serial connections, a Y-cable is used. The Y-cable connects the BSR and SPR to the BSDU and SDA, respectively, as well as to the PC running the WipLL management application.

Figure D-2 displays the Y-cable used to split the BSR/SPR 15-pin D-type port into two.

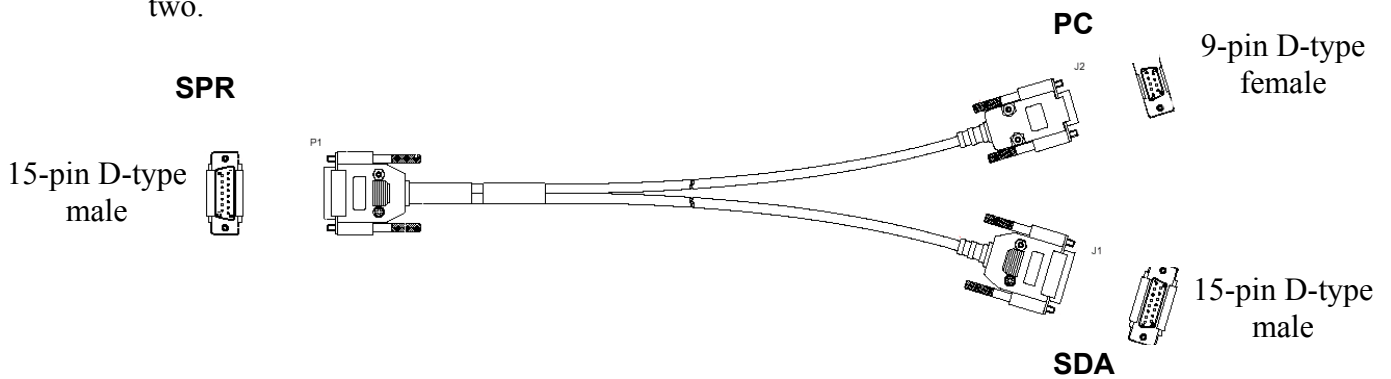

Figure D-2: Y-cable for serial connection

Connector pinouts are described in the following tables:

Table D-2: Y-cable SPR-to-SDA connector pinouts

Straight-through Y-cable					
SPR			SDA		
15-pin D-type male	Pin	Function	Pin	Function	15-pin D-type male
	1	0 VDC	1	+48 VDC	
	2	+48 VDC	2	-48 VDC	
	3	Ethernet Tx+	3	Rx+	
	4	Ethernet Tx-	4	Rx-	
	5	Ethernet Rx+	5	Tx+	
	6	Ethernet Rx-	6	Tx-	
	7	Hop Sync+	7	Sync.+	
	8	Hop Sync-	8	Sync.-	

Table D-3: Y-cable SPR-to-PC connector pinouts

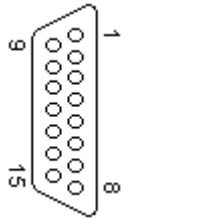
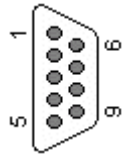
Straight-through Y-cable					
SPR			PC		
15-pin D-type male	Pin	Function	Pin	Function	9-pin D-type female
	12	GND	5	GND	
	14	RS232 Rx	3	Rx	
	15	RS232 Tx	2	Tx	

The Y-cable connector pin assignments are displayed schematically in Figure D-3.

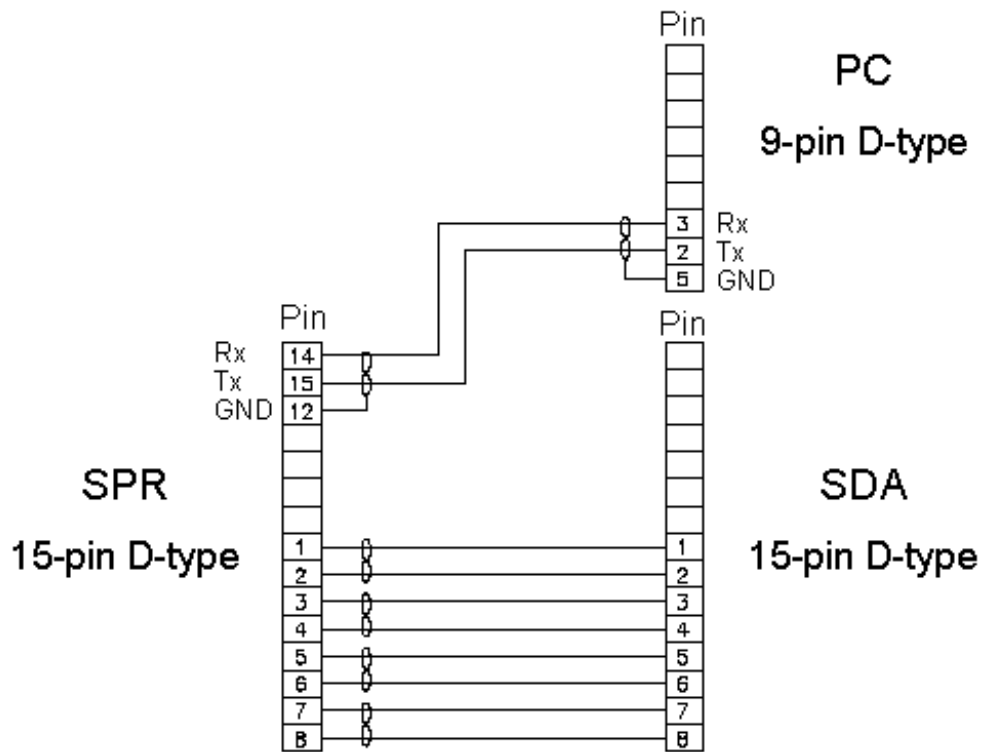
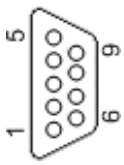
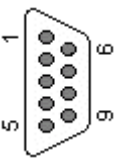

Figure D-3: Y-cable connector pin assignment

D.3. BSR Serial Connector Pinouts

The BSR provides a serial port for RS-232 serial interface to a PC. This serial communication connection allows you to perform BSR initial configuration.

Table D-4: BSR-to-PC serial connector pinouts

Crossover serial cable					
BSR			PC		
9-pin D-type male	Pin	Function	Pin	Function	9-pin D-type female
	1	Not connected (NC)	1	NC	
	2	RS232 Rx	3	Tx	
	3	RS232 Tx	2	Rx	
	4	NC	6	NC	
	5	GND	5	GND	
	6	NC	4	NC	
	7	NC	8	NC	
	8	NC	7	NC	
	9	NC	9	NC	

D.4. BSDU Connector Pinouts

D.4.1. BSDU Daisy Chaining

Table D-5: BSDU daisy chaining connector pinouts

Crossover cable			
8-pin RJ-45		Description	8-pin RJ-45
Pin	Name		Pin
1	Tx+	Transmit Data+	3
2	Tx-	Transmit Data-	6
3	Rx+	Receive Data+	1
6	Rx-	Receive Data-	2

D.4.2. BSDU Synchronization

■ Sync IN

Table D-6: BSDU synchronization (Sync IN) connector pinouts

Straight-through cable		
8-pin RJ-45 male		
Pin	Name	Description
1	TD+	Transmit data to GPS
2	TD-	Transmit data from GPS
3	Rx+	Receive Data (hop synchronization)
4	NC	Not connected
5	NC	Not connected
6	Rx-	Receive Data (hop synchronization)
7	1PPS+	GPS pulse per second
8	1PPS-	GPS pulse per second

■ Sync OUT

Table D-7: BSDU synchronization (Sync OUT) connector pinouts

Straight-through cable		
8-pin RJ-45 male		
Pin	Name	Description
1	TD+	Transmit data to GPS
2	TD-	Transmit data from GPS
3	Tx+	Transmit Data (hop synchronization)
4	RD+	Receive Data (from GPS)
5	RD-	Receive Data (to GPS)
6	Tx-	Transmit Data (hop synchronization)
7	1PPS+	GPS pulse per second
8	1PPS-	GPS pulse per second

D.4.3. BSDU Serial Management

The BSDU's serial management 9-Pin D-type port (labeled **Monitor**) allows you to connect the WipLL's network management system (WipConfig) to BSDU without assigning BSDU an IP address.

Table D-8: BSDU serial management connector pinouts

Straight-through	
9-Pin D-type male	
Pin	Signal
2	Rx
3	Tx

D.4.4. BSDU PC Network Management

For BSDU network management, you can connect the BSDU's two 10BaseT ports (i.e., loop the ports) to one another by a crossover cable, then connect the PC to one of the BSDU's 100BaseT ports. If the two BSDU 10BaseT ports are not connected to one another, then you need to connect the PC to the BSDU's right-most 10BaseT port (labeled **10Base-T 2**).

- Looping two 10Base-T ports:

Table D-9: BSDU 10Base-T connector pinouts for looping

Crossover cable	
8-pin RJ-45 male	
Pin	Signal
1	+Rx
2	-Rx
3	+Tx
6	-Tx

- 100Base-T port connected to PC

Table D-10: BSDU 100Base-T connector pinouts for management

Straight-through cable	
8-pin RJ-45	
Pin	Function
1	+Tx
2	-Tx
3	+Rx
6	-Rx

D.4.5. BSDU 100Base-T

Table D-11: BSDU 100Base-T LAN/WAN connector pinouts

Straight-through cable		
8-pin RJ-45		
Pin	Name	Description
1	Tx+	Transmit Data+
2	Tx-	Transmit Data-
3	Rx+	Receive Data+
6	Rx-	Receive Data-

D.5. GPS-to-BSDU Connector Pinouts

The following table lists the connector pinouts for the cable connecting the GPS antenna to the BSDU.

Table D-12: GPS-to-BSDU connector pinouts

12-pin female (GPS)			15-pin D-type male (BSDU)	
Pin	Pin name	Cable color	Pin	Lead
1	POWER	Red	9	
2	RX_DATA_1-	Blue	5	TD+ (after R5)
3	RX_DATA_1+	Black	6	TD-
4	TX_DATA_1-	Yellow	4	RD-
5	TX_DATA_1+	Black	3	RD+ (after R3)
6	RX_DATA_2-	Brown	x	
7	RX_DATA_2+	Black	x	
9	GND	Black	10	
11	1PPS+	Green	8	1PPS-
12	1PPS-	Black	7	1PPS+ (After R7)

D.6. Connector Pinouts for BPS Serial Management via BSDU

Table D-13: BPS serial management connector pinouts

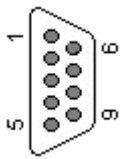
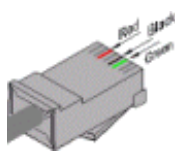
BSDU			BSPS		
9-pin D-type female	Pin	Function	Pin	Function	8-pin RJ-45
	2	Rx	6	Tx	
	3	Tx	3	Rx	
	5	GND	5	GND	

D.7. IDR Connector Pinouts

D.7.1. Serial Management Connection

Serial connection of the IDR to a PC is performed by connecting the IDR's RJ-11 port to the serial port (9-pin D-type) of the PC.

Table D-14: IDR serial management connector pinouts

Straight-through cable (IDR side)			Crossover cable (PC side)	
6-Pin RJ-11 male		9-Pin D-type female	9-Pin D-type male	9-Pin D-type female
Pin	Function	Pin	Pin	Pin
1	Rx	2	4	3
5	GND	5	1	5
6	Tx	3	3	2

D.7.2. Ethernet LAN Connection

The table below describes the connector pinouts for the Ethernet cable (CAT 5) that connects the IDR's Ethernet port to the PC's LAN port, using an 8-pin RJ-45 connector.

Table D-15: BSPS Ethernet LAN connector pinouts

8-pin RJ-45	
Pin	Function
1	Rx+
2	Rx-
3	Tx+
6	Tx-

D.8. SDA Ethernet LAN Connector Pinouts

- For SDA-1, SDA-4H (J2, J3, J4), and SDA-4S models (also for VoIP networks):

Table D-16: SDA Ethernet LAN connector pinouts

Straight-through cable	
8-pin RJ-45 male	
Pin	Function
1	+RX
2	-RX
3	+TX
6	-TX

- For J5 port on the SDA-4H:

Table D-17: SDA Ethernet LAN connector pinouts

Crossover cable	
8-pin RJ-45 male	
Pin	Function
1	+Tx
2	-Tx
3	+Rx
6	-Rx