



<b>Test specification: Section 96.41(e), Emission mask</b>			
<b>Test procedure:</b> Section 96.41(e)(3)			
<b>Test mode:</b> Compliance		<b>Verdict:</b> PASS	
<b>Date(s):</b> 21-Dec-18			
<b>Temperature:</b> 23 °C	<b>Relative Humidity:</b> 55 %	<b>Air Pressure:</b> 1008 hPa	<b>Power:</b> 48 VDC
<b>Remarks:</b>			

## 7.4 Emission outside the fundamental test

### 7.4.1 General

This test was performed to measure emission mask at RF antenna connector. Specification test limits are given in Table 7.4.1.

Table 7.4.1 Emission mask limits

Frequency displacement from frequency block	Limit*, dBm/MHz	RBW, kHz
<b>Channel Spacing 10 MHz</b>		
0 – 1 MHz	- 13	100
0 – 10 MHz	- 13	1000
10 – 20 MHz	- 25	1000
Above 3530 MHz and below 3720 MHz	- 25	1000
Below 3530 MHz and above 3720 MHz	- 40	1000
<b>Channel Spacing 20 MHz</b>		
0 – 1 MHz	- 13	200
0 – 10 MHz	- 13	1000
10 – 20 MHz	- 25	1000
Above 3530 MHz and below 3720 MHz	- 25	1000
Below 3530 MHz and above 3720 MHz	- 40	1000

\* - Limit at each antenna connector (amount of antennas N = 2)

### 7.4.2 Test procedure

7.4.2.1 The EUT was set up as shown in Figure 7.4.1, energized and its proper operation was checked.

7.4.2.2 The emission mask was measured with spectrum analyzer as provided in Table 7.4.2, Table 7.4.3 and the the associated plots.



<b>Test specification: Section 96.41(e), Emission mask</b>			
<b>Test procedure:</b> Section 96.41(e)(3)			
<b>Test mode:</b> Compliance		<b>Verdict: PASS</b>	
<b>Date(s):</b> 21-Dec-18			
<b>Temperature:</b> 23 °C	<b>Relative Humidity:</b> 55 %	<b>Air Pressure:</b> 1008 hPa	<b>Power:</b> 48 VDC
<b>Remarks:</b>			

Figure 7.4.1 Emission mask test setup

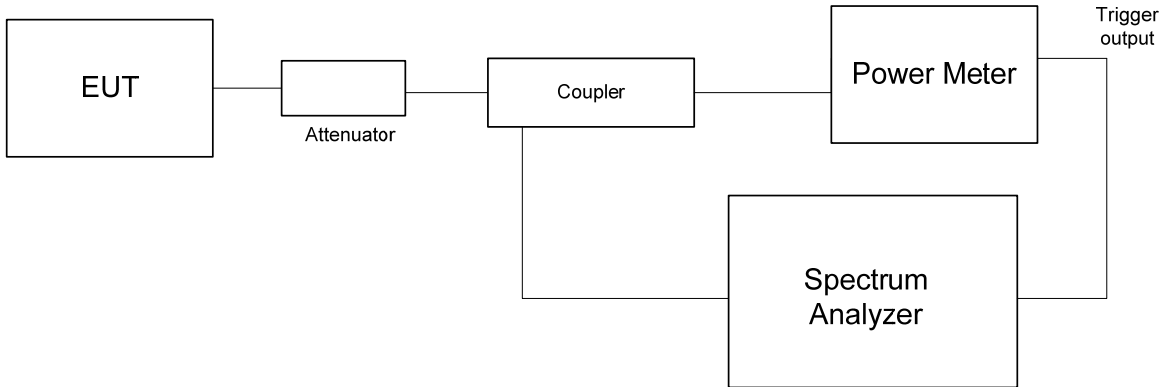



<b>Test specification: Section 96.41(e), Emission mask</b>			
<b>Test procedure:</b> Section 96.41(e)(3)			
<b>Test mode:</b> Compliance		<b>Verdict:</b> PASS	
<b>Date(s):</b> 21-Dec-18			
<b>Temperature:</b> 23 °C	<b>Relative Humidity:</b> 55 %	<b>Air Pressure:</b> 1008 hPa	<b>Power:</b> 48 VDC
<b>Remarks:</b>			

Table 7.4.2 Emission mask test results, CS=10 MHz

Modulation	Carrier frequency, MHz	Frequency displacement from EA frequency block	Test result, dBm/MHz	Limit*, dBm/MHz	Verdict
QPSK	Low	Within 0 to 10 MHz	-24.19	-16	Pass
		Greater than 10 MHz	-32.41	-28	Pass
		Below 3530 MHz	-43.16	-43	Pass
	Mid	Within 0 to 10 MHz	-21.05	-16	Pass
		Greater than 10 MHz	-31.34	-28	Pass
		Above 3720 MHz	-44.08	-43	Pass
	High	Within 0 to 10 MHz	-21.39	-16	Pass
		Greater than 10 MHz	-34.28	-28	Pass
		Above 3720 MHz	-44.08	-43	Pass
16 QAM	Low	Within 0 to 10 MHz	-23.77	-16	Pass
		Greater than 10 MHz	-31.13	-28	Pass
		Below 3530 MHz	-44.22	-43	Pass
	Mid	Within 0 to 10 MHz	-22.74	-16	Pass
		Greater than 10 MHz	-33.22	-28	Pass
		Above 3720 MHz	-43.79	-43	Pass
	High	Within 0 to 10 MHz	-22.13	-16	Pass
		Greater than 10 MHz	-33.14	-28	Pass
		Above 3720 MHz	-43.79	-43	Pass
64 QAM	Low	Within 0 to 10 MHz	-18.45	-16	Pass
		Greater than 10 MHz	-31.06	-28	Pass
		Below 3530 MHz	-43.68	-43	Pass
	Mid	Within 0 to 10 MHz	-23.19	-16	Pass
		Greater than 10 MHz	-33.11	-28	Pass
		Above 3720 MHz	-43.05	-43	Pass
	High	Within 0 to 10 MHz	-21.76	-16	Pass
		Greater than 10 MHz	-32.58	-28	Pass
		Above 3720 MHz	-43.05	-43	Pass

Note: Offset 48 dB included: coupling loss 16 dB, attenuator 30 dB, cables loss 2.0 dB  
\*The limit was reduced 3 dB due to 2 antennae.



<b>Test specification: Section 96.41(e), Emission mask</b>			
<b>Test procedure:</b> Section 96.41(e)(3)			
<b>Test mode:</b> Compliance		<b>Verdict: PASS</b>	
<b>Date(s):</b> 21-Dec-18			
<b>Temperature:</b> 23 °C	<b>Relative Humidity:</b> 55 %	<b>Air Pressure:</b> 1008 hPa	<b>Power:</b> 48 VDC
<b>Remarks:</b>			

Table 7.4.3 Emission mask test results, CS=20 MHz

Modulation	Carrier frequency, MHz	Frequency displacement from EA frequency block	Test result dBm/MHz	Limit* dBm/MHz	Verdict
QPSK	Low	Within 0 to 10 MHz	-27.06	-16	Pass
		Greater than 10 MHz	-32.41	-28	Pass
		Below 3530 MHz	-43.17	-43	Pass
	Mid	Within 0 to 10 MHz	-23.65	-16	Pass
		Greater than 10 MHz	-31.07	-28	Pass
		Above 3720 MHz	-43.15	-43	Pass
	High	Within 0 to 10 MHz	-30.92	-16	Pass
		Greater than 10 MHz	-35.04	-28	Pass
		Above 3720 MHz	-43.15	-43	Pass
16 QAM	Low	Within 0 to 10 MHz	-26.30	-16	Pass
		Greater than 10 MHz	-31.44	-28	Pass
		Below 3530 MHz	-43.15	-43	Pass
	Mid	Within 0 to 10 MHz	-24.44	-16	Pass
		Greater than 10 MHz	-30.28	-28	Pass
		Above 3720 MHz	-43.03	-43	Pass
	High	Within 0 to 10 MHz	-30.57	-16	Pass
		Greater than 10 MHz	-35.30	-28	Pass
		Above 3720 MHz	-43.03	-43	Pass
64 QAM	Low	Within 0 to 10 MHz	-26.97	-16	Pass
		Greater than 10 MHz	-31.62	-28	Pass
		Below 3530 MHz	-43.14	-43	Pass
	Mid	Within 0 to 10 MHz	-23.63	-16	Pass
		Greater than 10 MHz	-28.71	-28	Pass
		Above 3720 MHz	-43.10	-43	Pass
	High	Within 0 to 10 MHz	-29.81	-16	Pass
		Greater than 10 MHz	-36.23	-28	Pass
		Above 3720 MHz	-43.10	-43	Pass

\*The limit was reduced 3 dB due to 2 antennae.

**Reference numbers of test equipment used**

HL 3818						
---------	--	--	--	--	--	--

Full description is given in Appendix A.



HERMON LABORATORIES

<b>Test specification:</b> Section 96.41(e), Emission mask			
<b>Test procedure:</b> Section 96.41(e)(3)			
<b>Test mode:</b> Compliance		<b>Verdict:</b>	<b>PASS</b>
<b>Date(s):</b> 21-Dec-18			
<b>Temperature:</b> 23 °C	<b>Relative Humidity:</b> 55 %	<b>Air Pressure:</b> 1008 hPa	<b>Power:</b> 48 VDC
<b>Remarks:</b>			

Plot 7.4.1 Emission outside the fundamental test results at low carrier frequency

CHANNEL SPACING:  
ANTENNA CHAIN:  
Modulation: QPSK

\* Agilent

R T

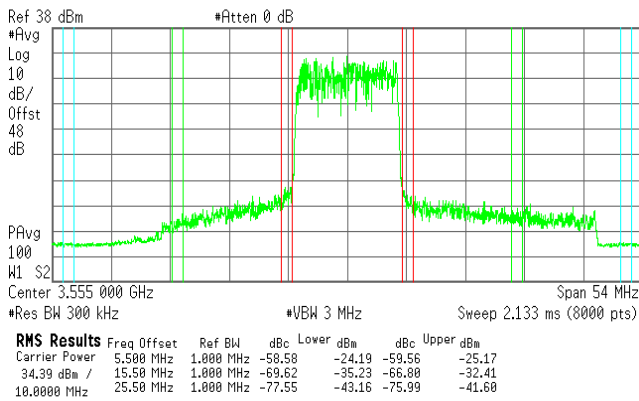

10 MHz  
1

Modulation: 16 QAM

\* Agilent

R T

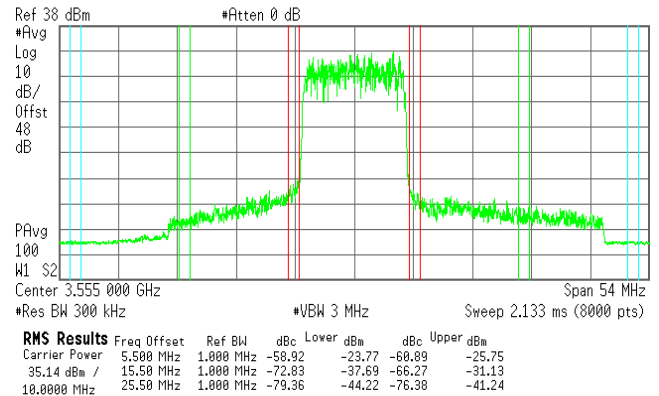

Modulation: 64 QAM

\* Agilent

R T

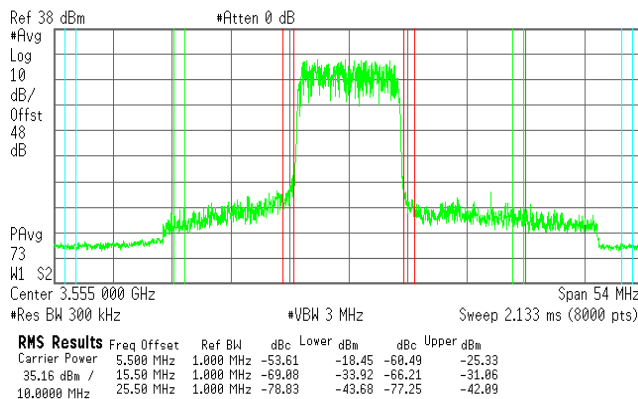



HERMON LABORATORIES

<b>Test specification:</b> Section 96.41(e), Emission mask			
<b>Test procedure:</b> Section 96.41(e)(3)			
<b>Test mode:</b> Compliance		<b>Verdict:</b> PASS	
<b>Date(s):</b> 21-Dec-18			
<b>Temperature:</b> 23 °C	<b>Relative Humidity:</b> 55 %	<b>Air Pressure:</b> 1008 hPa	<b>Power:</b> 48 VDC
<b>Remarks:</b>			

Plot 7.4.2 Emission outside the fundamental test results at mid carrier frequency

CHANNEL SPACING:  
ANTENNA CHAIN:  
Modulation: QPSK

10 MHz  
1  
Modulation: 16 QAM

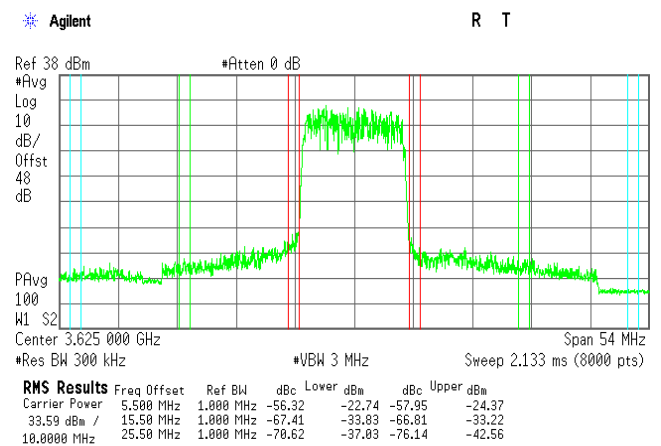
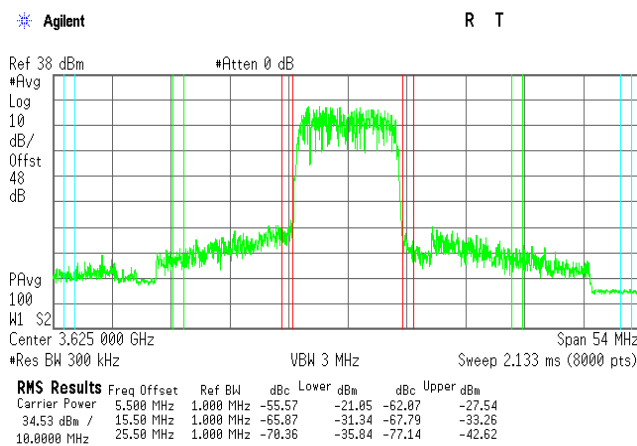

Modulation:64 QAM

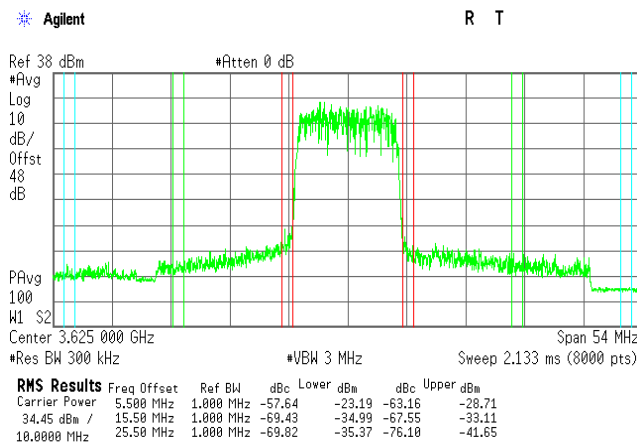



HERMON LABORATORIES

<b>Test specification:</b> Section 96.41(e), Emission mask			
<b>Test procedure:</b> Section 96.41(e)(3)			
<b>Test mode:</b> Compliance		<b>Verdict:</b> PASS	
<b>Date(s):</b> 21-Dec-18			
<b>Temperature:</b> 23 °C	<b>Relative Humidity:</b> 55 %	<b>Air Pressure:</b> 1008 hPa	<b>Power:</b> 48 VDC
<b>Remarks:</b>			

Plot 7.4.3 Emission outside the fundamental test results at high carrier frequency

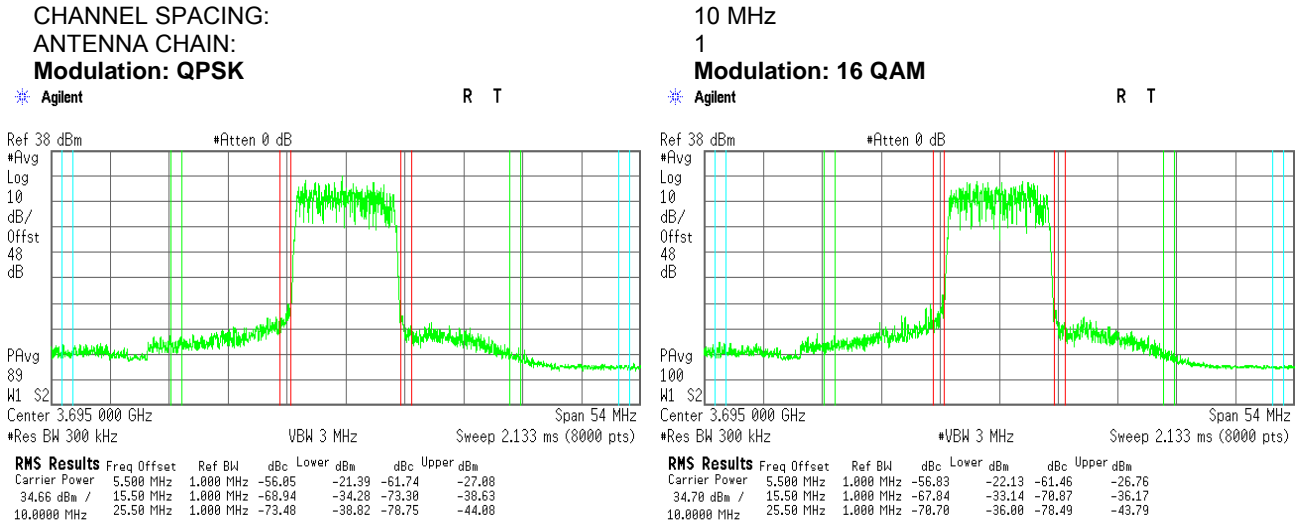

Modulation: 64 QAM

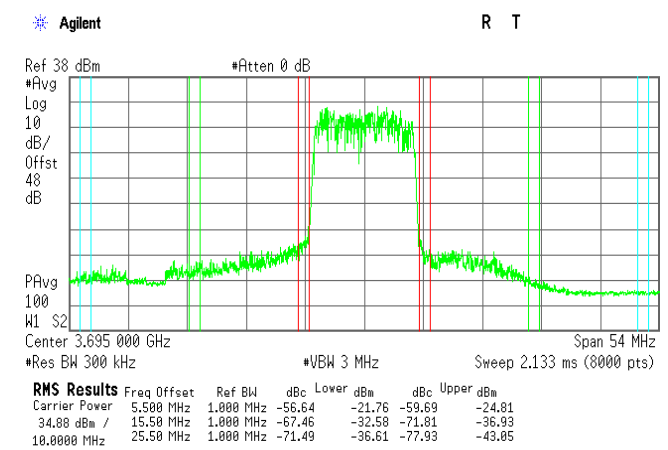



<b>Test specification:</b> Section 96.41(e), Emission mask			
<b>Test procedure:</b> Section 96.41(e)(3)			
<b>Test mode:</b> Compliance		<b>Verdict:</b> PASS	
<b>Date(s):</b> 21-Dec-18			
<b>Temperature:</b> 23 °C	<b>Relative Humidity:</b> 55 %	<b>Air Pressure:</b> 1008 hPa	<b>Power:</b> 48 VDC
<b>Remarks:</b>			

Plot 7.4.4 Emission mask test results at low carrier frequency

MODULATION: QPSK  
CHANNEL SPACING: 20 MHz  
ANTENNA CHAIN: 1

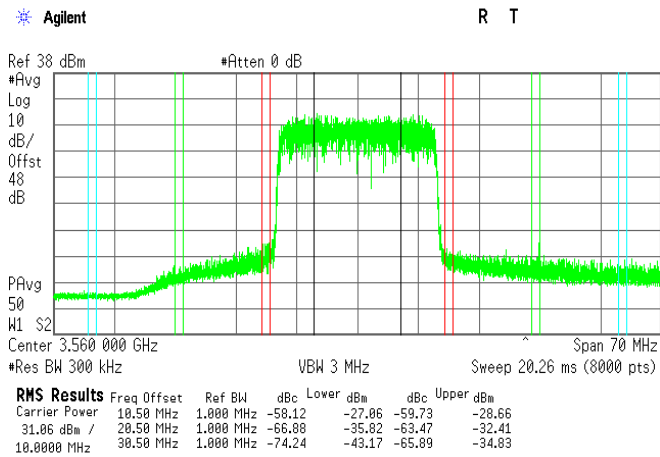

Plot 7.4.5 Emission mask test results at low carrier frequency

MODULATION: 16QAM  
CHANNEL SPACING: 20 MHz  
ANTENNA CHAIN: 1

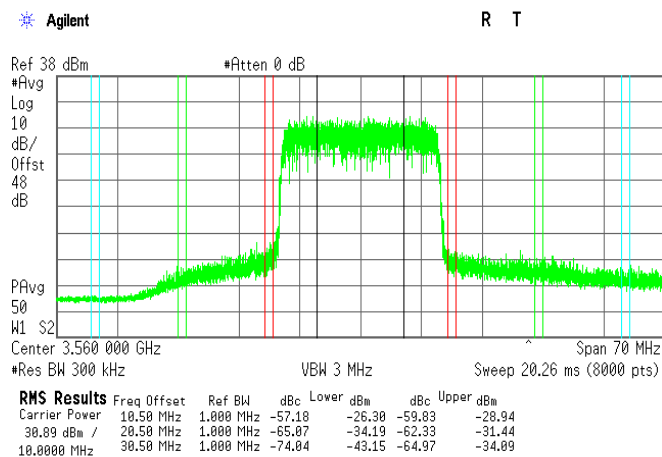





HERMON LABORATORIES

<b>Test specification:</b> Section 96.41(e), Emission mask			
<b>Test procedure:</b> Section 96.41(e)(3)			
<b>Test mode:</b> Compliance		<b>Verdict:</b> PASS	
<b>Date(s):</b> 21-Dec-18			
<b>Temperature:</b> 23 °C	<b>Relative Humidity:</b> 55 %	<b>Air Pressure:</b> 1008 hPa	<b>Power:</b> 48 VDC
<b>Remarks:</b>			

Plot 7.4.6 Emission mask test results at low carrier frequency

MODULATION: 64QAM  
CHANNEL SPACING: 20 MHz  
ANTENNA CHAIN: 1

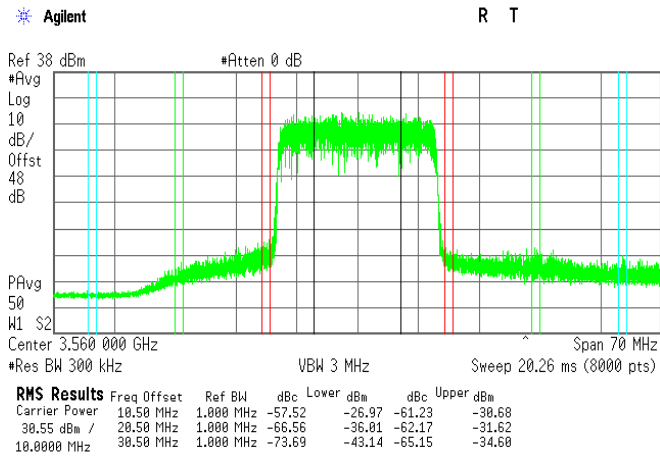

Plot 7.4.7 Emission mask test results at mid carrier frequency

MODULATION: QPSK  
CHANNEL SPACING: 20 MHz  
ANTENNA CHAIN: 1

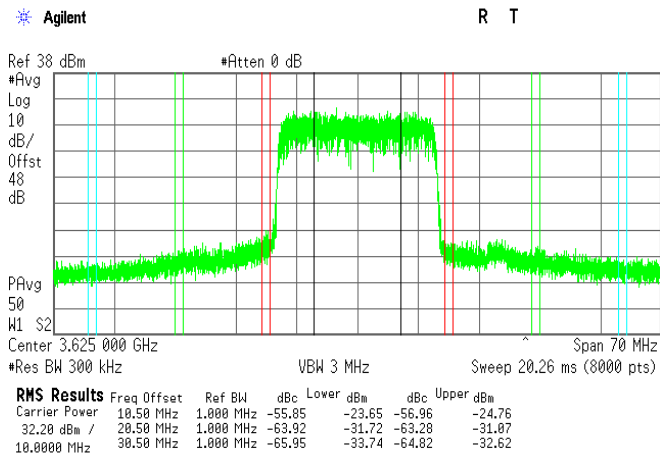



<b>Test specification:</b> Section 96.41(e), Emission mask			
<b>Test procedure:</b> Section 96.41(e)(3)			
<b>Test mode:</b> Compliance		<b>Verdict:</b> PASS	
<b>Date(s):</b> 21-Dec-18			
<b>Temperature:</b> 23 °C	<b>Relative Humidity:</b> 55 %	<b>Air Pressure:</b> 1008 hPa	<b>Power:</b> 48 VDC
<b>Remarks:</b>			

Plot 7.4.8 Emission mask test results at mid carrier frequency

MODULATION: 16QAM  
CHANNEL SPACING: 20 MHz  
ANTENNA CHAIN: 1

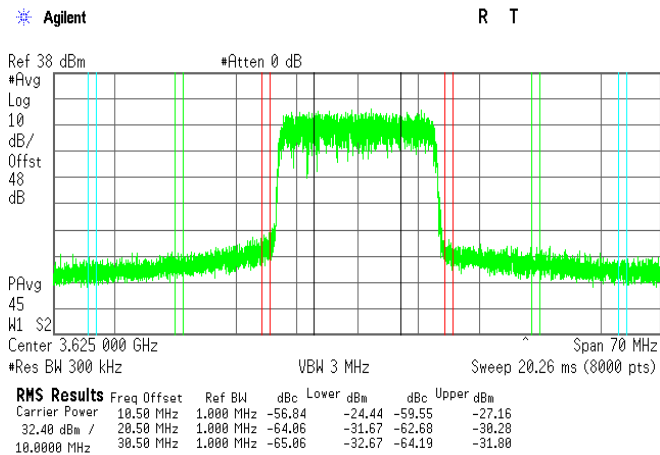

Plot 7.4.9 Emission mask test results at mid carrier frequency

MODULATION: 64QAM  
CHANNEL SPACING: 20 MHz  
ANTENNA CHAIN: 1

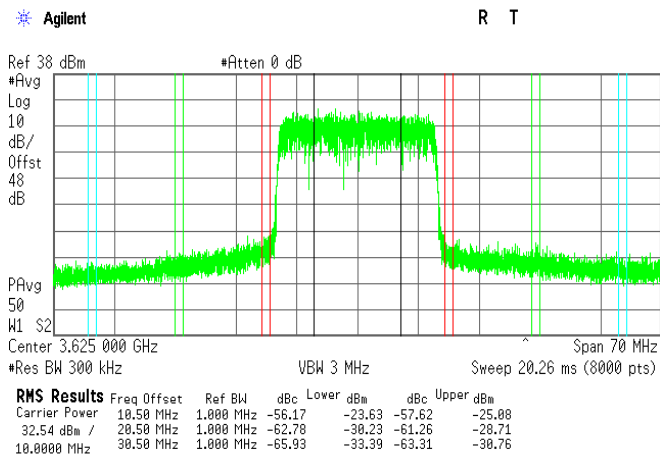



<b>Test specification:</b> Section 96.41(e), Emission mask			
<b>Test procedure:</b> Section 96.41(e)(3)			
<b>Test mode:</b> Compliance		<b>Verdict:</b> PASS	
<b>Date(s):</b> 21-Dec-18			
<b>Temperature:</b> 23 °C	<b>Relative Humidity:</b> 55 %	<b>Air Pressure:</b> 1008 hPa	<b>Power:</b> 48 VDC
<b>Remarks:</b>			

Plot 7.4.10 Emission mask test results at high carrier frequency

MODULATION: QPSK  
CHANNEL SPACING: 20 MHz  
ANTENNA CHAIN: 1

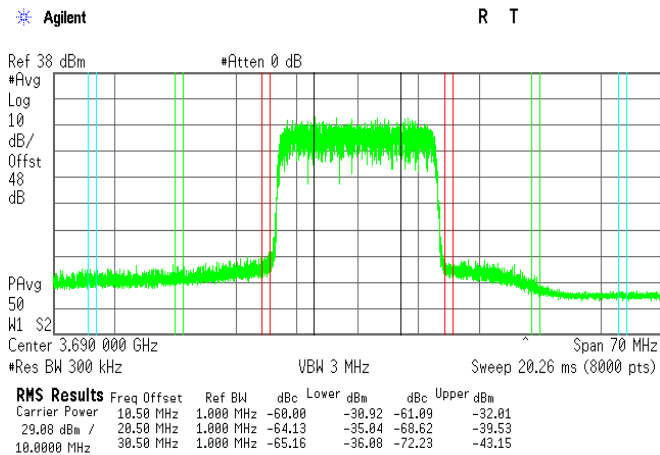

Plot 7.4.11 Emission mask test results at high carrier frequency

MODULATION: 16QAM  
CHANNEL SPACING: 20 MHz  
ANTENNA CHAIN: 1

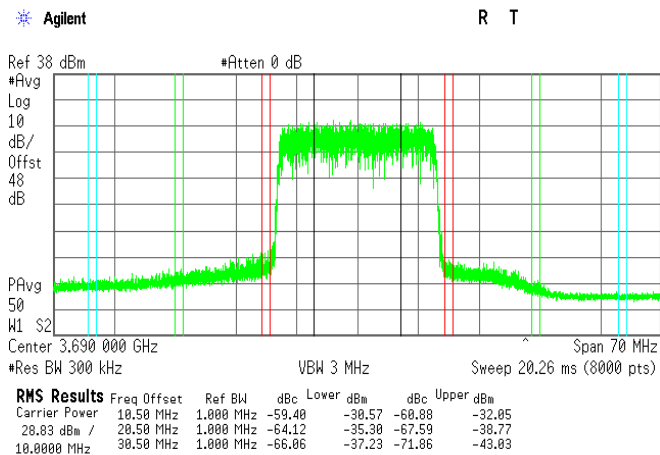



HERMON LABORATORIES

<b>Test specification:</b> Section 96.41(e), Emission mask			
<b>Test procedure:</b> Section 96.41(e)(3)			
<b>Test mode:</b> Compliance		<b>Verdict:</b> PASS	
<b>Date(s):</b> 21-Dec-18			
<b>Temperature:</b> 23 °C	<b>Relative Humidity:</b> 55 %	<b>Air Pressure:</b> 1008 hPa	<b>Power:</b> 48 VDC
<b>Remarks:</b>			

Plot 7.4.12 Emission mask test results at high carrier frequency

MODULATION: 64QAM  
CHANNEL SPACING: 20 MHz  
ANTENNA CHAIN: 1

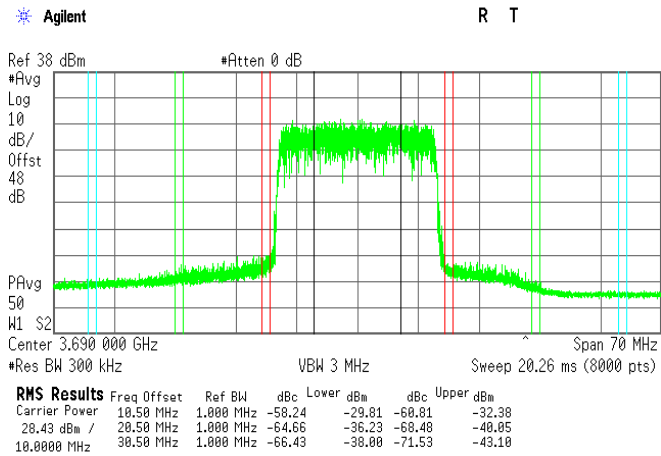



<b>Test specification: Section 96.41(e)(2), Radiated spurious emissions</b>			
<b>Test procedure:</b> Section 96.41(e)(3)			
<b>Test mode:</b> Compliance		<b>Verdict: PASS</b>	
<b>Date(s):</b> 18-Dec-18			
<b>Temperature:</b> 24 °C	<b>Relative Humidity:</b> 52 %	<b>Air Pressure:</b> 1020 hPa	<b>Power:</b> 48 VDC
<b>Remarks:</b>			

## 7.5 Radiated spurious emission measurements

### 7.5.1 General

This test was performed to measure radiated spurious emissions from the EUT. Specification test limits are given in Table 7.5.1.

Table 7.5.1 Radiated spurious emission test limits

Frequency, MHz	EIRP of spurious, dBm	Equivalent field strength limit @ 3m, dB(μV/m)***
0.09 – below 3530.0	-40.0	55.2
3720.0 – 10th harmonic*	-40.0	55.2

\*\*\* - Equivalent field strength limit was calculated from maximum allowed ERP of spurious as follows:  $E = \sqrt{30 \times P \times 1.64} / r$ , where P is ERP in Watts, 1.64 is numeric gain of ideal dipole and r is antenna to EUT distance in meters

### 7.5.2 Test procedure for spurious emission field strength measurements in 9 kHz to 30 MHz band

7.5.2.1 The EUT was set up as shown in Figure 7.5.1, energized and the performance check was conducted.

7.5.2.2 The specified frequency range was investigated with antenna connected to spectrum analyzer. To find maximum radiation the turntable was rotated 360° and the measuring antenna was rotated around its vertical axis.

7.5.2.3 The worst test results (the lowest margins) were recorded in Table 7.5.2 and shown in the associated plots.

### 7.5.3 Test procedure for spurious emission field strength measurements above 30 MHz

7.5.3.1 The EUT was set up as shown in Figure 7.5.2, energized and the performance check was conducted.

7.5.3.2 The specified frequency range was investigated with antenna connected to spectrum analyzer. To find maximum radiation the turntable was rotated 360° and the measuring antenna height was swept from 1 to 4 m in both, vertical and horizontal, polarizations.

7.5.3.3 The worst test results (the lowest margins) were recorded in Table 7.5.2 and shown in the associated plots.



<b>Test specification: Section 96.41(e)(2), Radiated spurious emissions</b>			
<b>Test procedure:</b> Section 96.41(e)(3)			
<b>Test mode:</b> Compliance		<b>Verdict:</b> PASS	
<b>Date(s):</b> 18-Dec-18			
<b>Temperature:</b> 24 °C	<b>Relative Humidity:</b> 52 %	<b>Air Pressure:</b> 1020 hPa	<b>Power:</b> 48 VDC
<b>Remarks:</b>			

Figure 7.5.1 Setup for spurious emission field strength measurements in 9 kHz to 30 MHz band

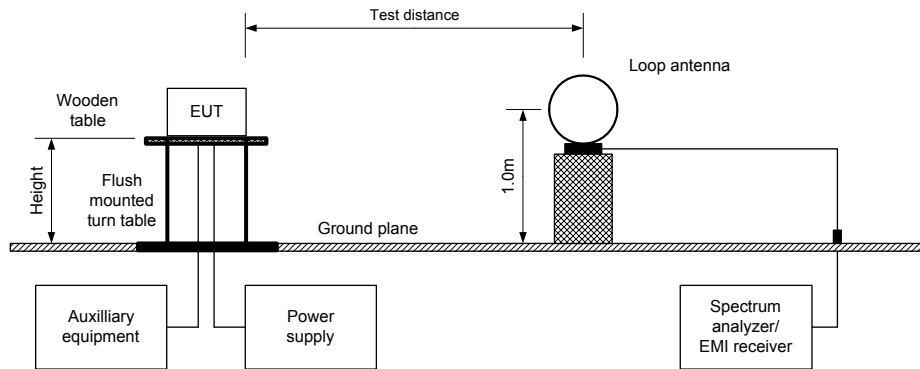
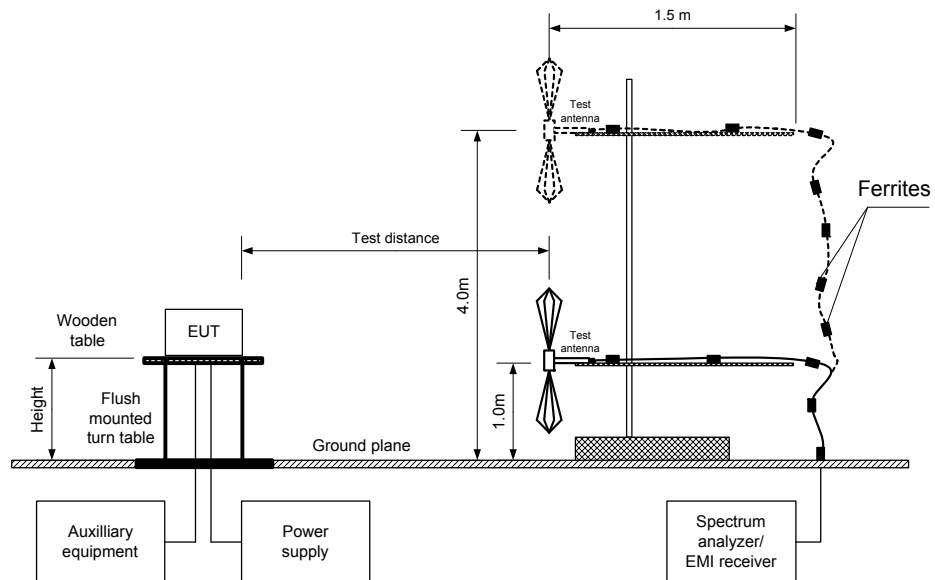

Figure 7.5.2 Setup for spurious emission field strength measurements above 30 MHz





<b>Test specification: Section 96.41(e)(2), Radiated spurious emissions</b>			
<b>Test procedure:</b> Section 96.41(e)(3)			
<b>Test mode:</b> Compliance		<b>Verdict: PASS</b>	
<b>Date(s):</b> 18-Dec-18			
<b>Temperature:</b> 24 °C	<b>Relative Humidity:</b> 52 %	<b>Air Pressure:</b> 1020 hPa	<b>Power:</b> 48 VDC
<b>Remarks:</b>			

**Table 7.5.2 Spurious emission field strength test results**

ASSIGNED FREQUENCY RANGE: 3550 - 3700 MHz  
 TEST DISTANCE: 3 m  
 TEST SITE: Semi anechoic chamber  
 INVESTIGATED FREQUENCY RANGE: 0.009 – 37000 MHz  
 DETECTOR USED: Peak  
 VIDEO BANDWIDTH: > Resolution bandwidth  
 TEST ANTENNA TYPE: Active loop (9 kHz – 30 MHz)  
 Biconilog (30 MHz – 1000 MHz)  
 Double ridged guide (above 1000 MHz)  
 MODULATION: QPSK  
 MODULATING SIGNAL: PRBS  
 TRANSMITTER OUTPUT POWER SETTINGS: Maximum

Frequency, MHz	Field strength, dB(μV/m)	Limit, dB(μV/m)	Margin, dB*	RBW, kHz	Antenna polarization	Antenna height, cm	Turn-table position**, degrees	Verdict
<b>Low, mid and high frequency</b>								
33.258	51.41	55.2	-3.79	100	Vertical	104	-173	Pass
499.190	39.78	55.2	-15.42	100	Vertical	102	62	Pass
1267.228	38.61	55.2	-16.59	1000	Horizontal	162	-149	Pass
1420.955	39.21	55.2	-15.99	1000	Horizontal	192	-121	Pass
1843.067	41.09	55.2	-14.11	1000	Vertical	192	-162	Pass
2400.227	39.81	55.2	-15.39	1000	Vertical	100	180	Pass
<b>Mid frequency</b>								
7250.075	51.27	55.2	-3.93	1000	Vertical	263	-167	Pass
<b>High frequency</b>								
7393.410	45.84	55.2	-9.36	1000	Vertical	223	22	Pass

\*- Margin = Field strength of spurious – calculated field strength limit.

\*\* - EUT front panel refers to 0 degrees position of turntable.

**Reference numbers of test equipment used**

HL 0446	HL 3903	HL 4360	HL 4933	HL 4956	HL 5111	HL 5288	HL 5405
---------	---------	---------	---------	---------	---------	---------	---------

Full description is given in Appendix A.



<b>Test specification: Section 96.41(e)(2), Radiated spurious emissions</b>			
Test procedure: Section 96.41(e)(3)			
Test mode: Compliance		Verdict: <b>PASS</b>	
Date(s): 18-Dec-18			
Temperature: 24 °C	Relative Humidity: 52 %	Air Pressure: 1020 hPa	Power: 48 VDC
Remarks:			

Plot 7.5.1 Radiated emission measurements in 9 kHz - 30 MHz range

TEST SITE: Semi anechoic chamber  
 CARRIER FREQUENCY: Low  
 TEST DISTANCE: 3 m

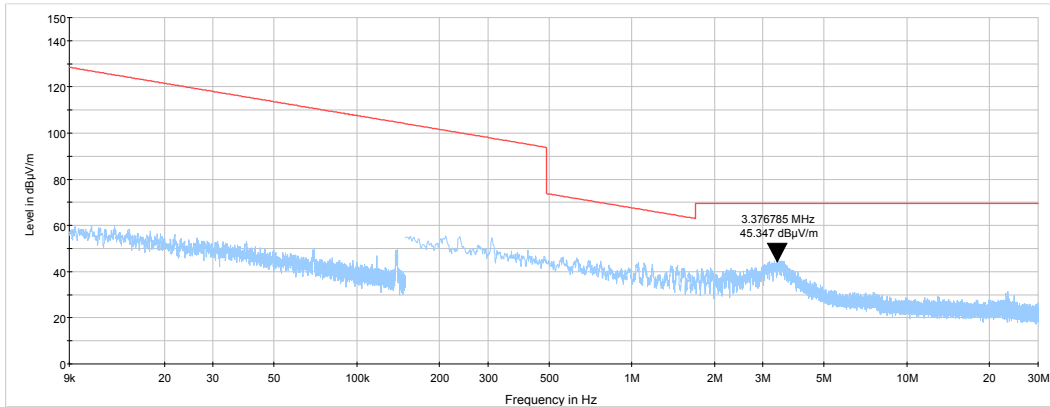

Plot 7.5.2 Radiated emission measurements in 9 kHz - 30 MHz range

TEST SITE: Semi anechoic chamber  
 CARRIER FREQUENCY: Mid  
 TEST DISTANCE: 3 m

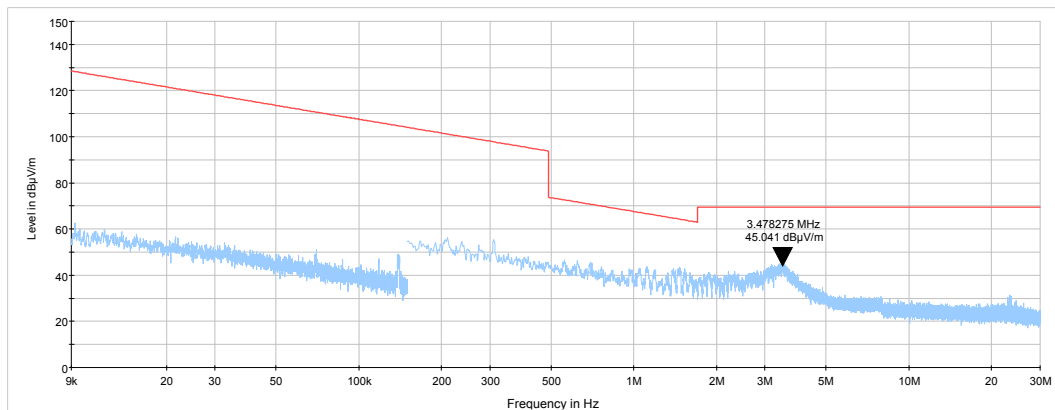





HERMON LABORATORIES

<b>Test specification: Section 96.41(e)(2), Radiated spurious emissions</b>			
<b>Test procedure:</b> Section 96.41(e)(3)			
<b>Test mode:</b> Compliance		<b>Verdict:</b> PASS	
<b>Date(s):</b> 18-Dec-18			
<b>Temperature:</b> 24 °C	<b>Relative Humidity:</b> 52 %	<b>Air Pressure:</b> 1020 hPa	<b>Power:</b> 48 VDC
<b>Remarks:</b>			

**Plot 7.5.3 Radiated emission measurements in 9 kHz - 30 MHz range**

TEST SITE: Semi anechoic chamber  
CARRIER FREQUENCY: High  
TEST DISTANCE: 3 m

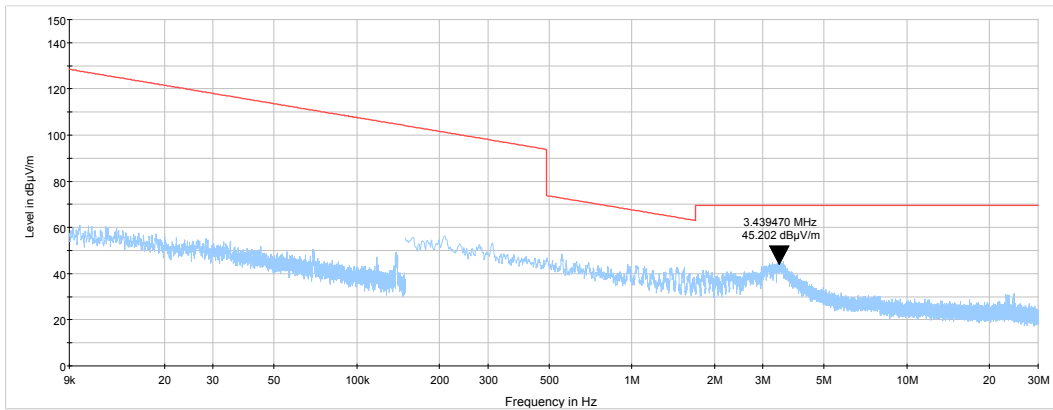



<b>Test specification: Section 96.41(e)(2), Radiated spurious emissions</b>			
<b>Test procedure:</b> Section 96.41(e)(3)			
<b>Test mode:</b> Compliance		<b>Verdict: PASS</b>	
<b>Date(s):</b> 18-Dec-18			
<b>Temperature:</b> 24 °C	<b>Relative Humidity:</b> 52 %	<b>Air Pressure:</b> 1020 hPa	<b>Power:</b> 48 VDC
<b>Remarks:</b>			

**Plot 7.5.4 Radiated emission measurements in 30 - 1000 MHz range**

TEST SITE: Semi anechoic chamber  
 CARRIER FREQUENCY: Low  
 ANTENNA POLARIZATION: Vertical and Horizontal  
 TEST DISTANCE: 3 m

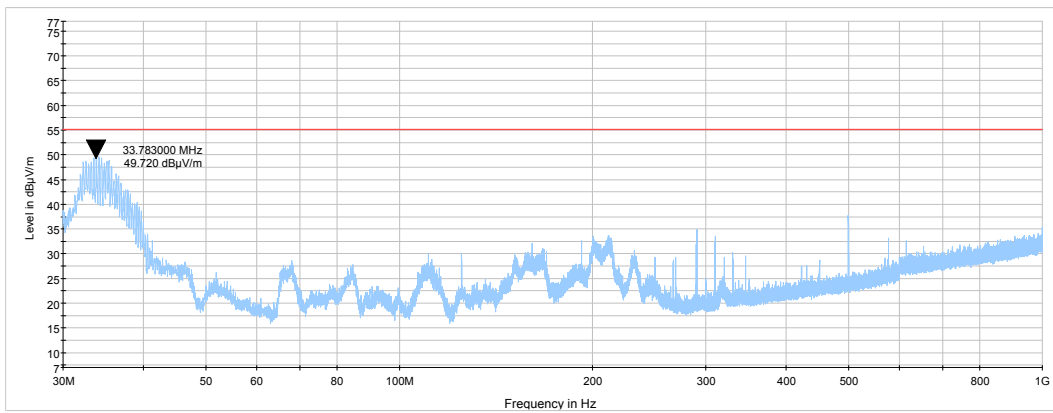

**Plot 7.5.5 Radiated emission measurements in 30 - 1000 MHz range**

TEST SITE: Semi anechoic chamber  
 CARRIER FREQUENCY: Mid  
 ANTENNA POLARIZATION: Vertical and Horizontal  
 TEST DISTANCE: 3 m

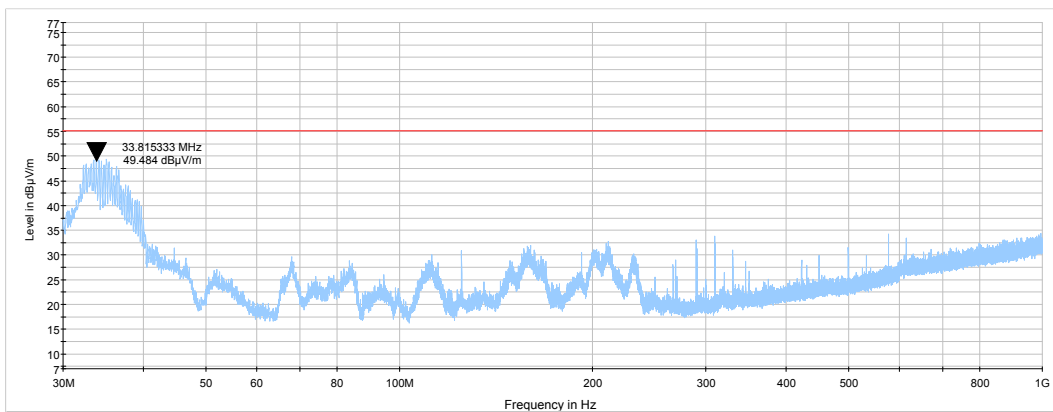



<b>Test specification: Section 96.41(e)(2), Radiated spurious emissions</b>			
<b>Test procedure:</b> Section 96.41(e)(3)			
<b>Test mode:</b> Compliance		<b>Verdict:</b> PASS	
<b>Date(s):</b> 18-Dec-18			
<b>Temperature:</b> 24 °C	<b>Relative Humidity:</b> 52 %	<b>Air Pressure:</b> 1020 hPa	<b>Power:</b> 48 VDC
<b>Remarks:</b>			

Plot 7.5.6 Radiated emission measurements in 30 - 1000 MHz range

TEST SITE:	Semi anechoic chamber
CARRIER FREQUENCY:	High
ANTENNA POLARIZATION:	Vertical and Horizontal
TEST DISTANCE:	3 m

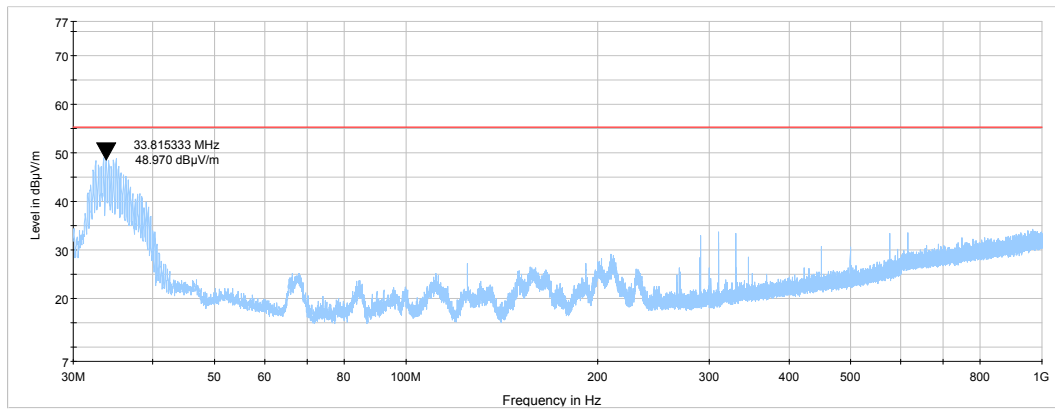



<b>Test specification: Section 96.41(e)(2), Radiated spurious emissions</b>			
<b>Test procedure:</b> Section 96.41(e)(3)			
<b>Test mode:</b> Compliance		<b>Verdict: PASS</b>	
<b>Date(s):</b> 18-Dec-18			
<b>Temperature:</b> 24 °C	<b>Relative Humidity:</b> 52 %	<b>Air Pressure:</b> 1020 hPa	<b>Power:</b> 48 VDC
<b>Remarks:</b>			

**Plot 7.5.7 Radiated emission measurements in 1000 – 18000 MHz range**

TEST SITE: Semi anechoic chamber  
 CARRIER FREQUENCY: Low  
 ANTENNA POLARIZATION: Vertical and Horizontal  
 TEST DISTANCE: 3 m

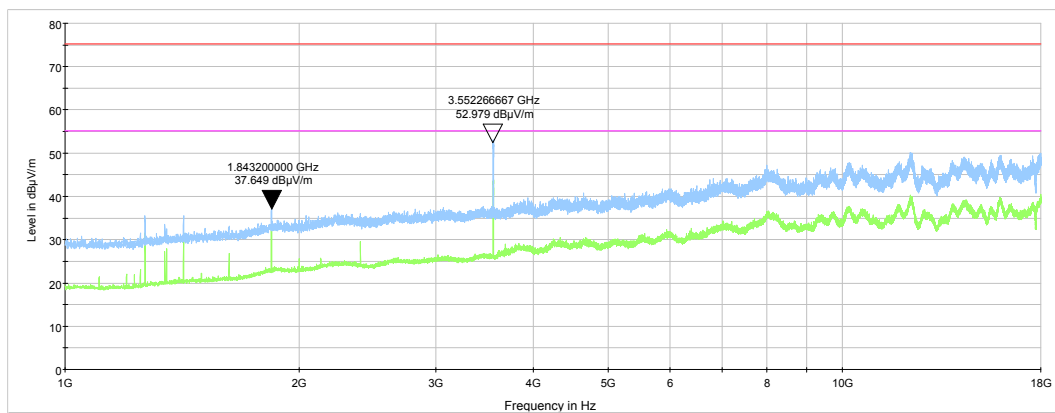

**Plot 7.5.8 Radiated emission measurements in 1000 – 18000 MHz range**

TEST SITE: Semi anechoic chamber  
 CARRIER FREQUENCY: Mid  
 ANTENNA POLARIZATION: Vertical and Horizontal  
 TEST DISTANCE: 3 m

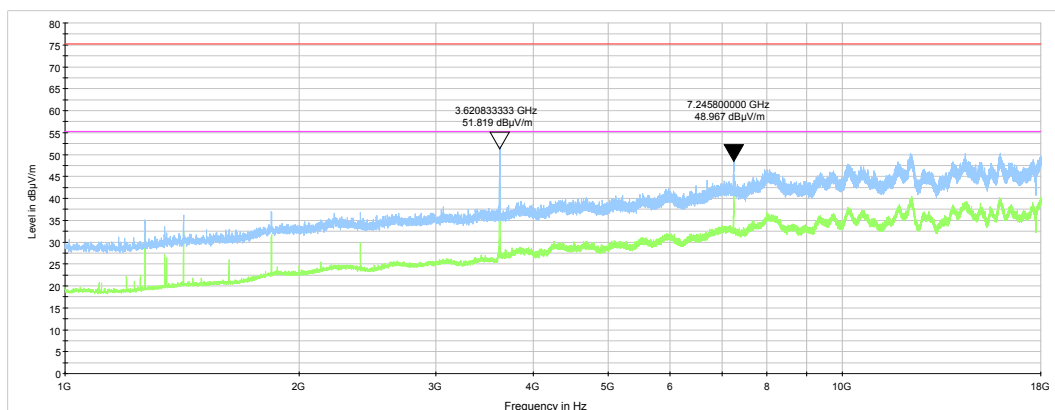



<b>Test specification: Section 96.41(e)(2), Radiated spurious emissions</b>			
<b>Test procedure:</b> Section 96.41(e)(3)			
<b>Test mode:</b> Compliance		<b>Verdict:</b> PASS	
<b>Date(s):</b> 18-Dec-18			
<b>Temperature:</b> 24 °C	<b>Relative Humidity:</b> 52 %	<b>Air Pressure:</b> 1020 hPa	<b>Power:</b> 48 VDC
<b>Remarks:</b>			

Plot 7.5.9 Radiated emission measurements in 1000 – 18000 MHz range

TEST SITE: Semi anechoic chamber  
CARRIER FREQUENCY: High  
ANTENNA POLARIZATION: Vertical and Horizontal  
TEST DISTANCE: 3 m

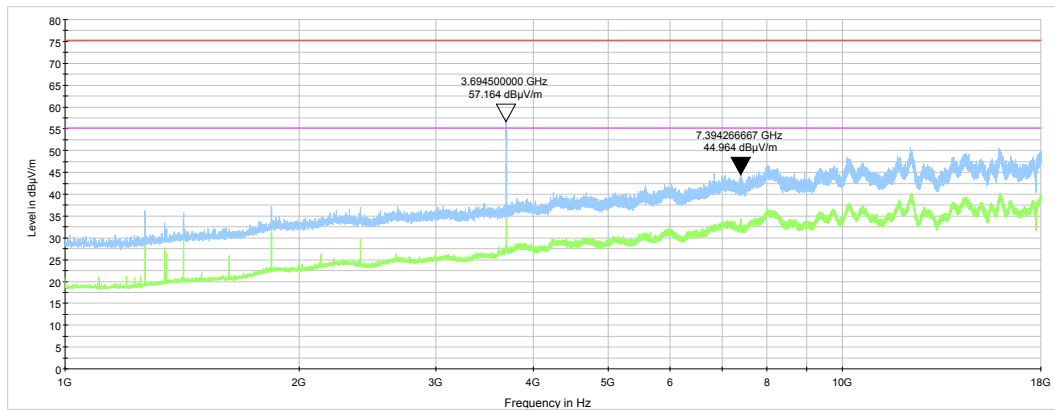



<b>Test specification: Section 96.41(e)(2), Radiated spurious emissions</b>			
<b>Test procedure:</b> Section 96.41(e)(3)			
<b>Test mode:</b> Compliance		<b>Verdict: PASS</b>	
<b>Date(s):</b> 18-Dec-18			
<b>Temperature:</b> 24 °C	<b>Relative Humidity:</b> 52 %	<b>Air Pressure:</b> 1020 hPa	<b>Power:</b> 48 VDC
<b>Remarks:</b>			

**Plot 7.5.10 Radiated emission measurements in 18000 – 37000 MHz range**

TEST SITE: Semi anechoic chamber  
 CARRIER FREQUENCY: Low  
 ANTENNA POLARIZATION: Vertical and Horizontal  
 TEST DISTANCE: 3 m

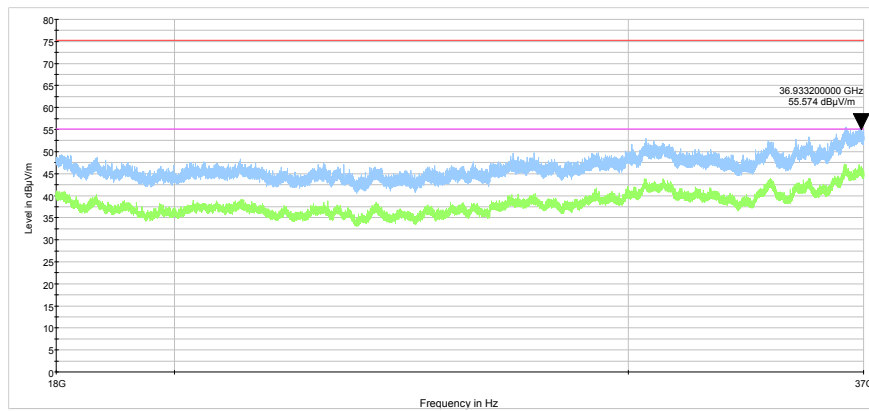

**Plot 7.5.11 Radiated emission measurements in 18000 – 37000 MHz range**

TEST SITE: Semi anechoic chamber  
 CARRIER FREQUENCY: Mid  
 ANTENNA POLARIZATION: Vertical and Horizontal  
 TEST DISTANCE: 3 m

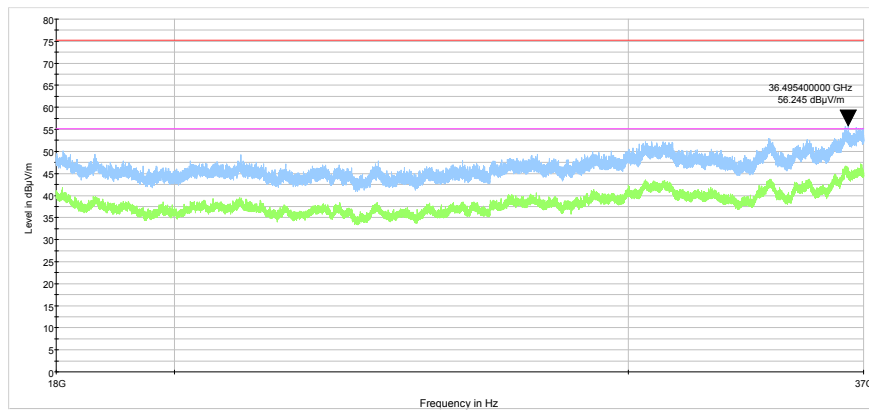



<b>Test specification: Section 96.41(e)(2), Radiated spurious emissions</b>			
<b>Test procedure:</b> Section 96.41(e)(3)			
<b>Test mode:</b> Compliance		<b>Verdict: PASS</b>	
<b>Date(s):</b> 18-Dec-18			
<b>Temperature:</b> 24 °C	<b>Relative Humidity:</b> 52 %	<b>Air Pressure:</b> 1020 hPa	<b>Power:</b> 48 VDC
<b>Remarks:</b>			

Plot 7.5.12 Radiated emission measurements in 18000 – 37000 MHz range

TEST SITE: Semi anechoic chamber  
CARRIER FREQUENCY: High  
ANTENNA POLARIZATION: Vertical and Horizontal  
TEST DISTANCE: 3 m

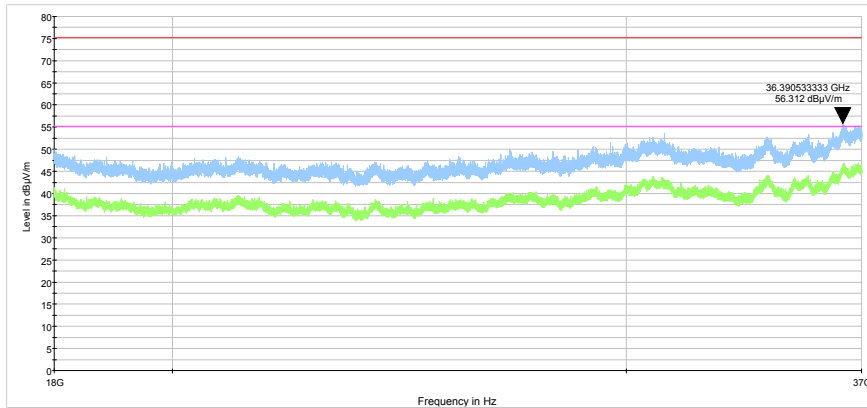



<b>Test specification: Section 96.41(e)(3), Conducted spurious emissions</b>			
<b>Test procedure:</b> Section 96.41(e)(3)			
<b>Test mode:</b> Compliance		<b>Verdict: PASS</b>	
<b>Date(s):</b> 23-Dec-18			
<b>Temperature:</b> 24.3 °C	<b>Relative Humidity:</b> 48 %	<b>Air Pressure:</b> 1009 hPa	<b>Power:</b> 48 VDC
<b>Remarks:</b>			

## 7.6 Spurious emissions at RF antenna connector test

### 7.6.1 General

This test was performed to measure spurious emissions at RF antenna connector. Specification test limits are given in Table 7.6.1.

Table 7.6.1 Spurious emission limits

Frequency offset from channel band edge, MHz	Attenuation below carrier, dBc	ERP of spurious, dBm
0 – 10	NA	-13.0
10 – 20	NA	-25.0
More than 20	NA	-40.0

\* - spurious emission limits do not apply to the in band emission within  $\pm 250$  % of the authorized bandwidth from the carrier; investigated in course of emission mask testing

\*\* - P is transmitter output power in Watts

### 7.6.2 Test procedure

7.6.2.1 The EUT was set up as shown in Figure 7.6.1, energized and its proper operation was checked.

7.6.2.2 The EUT was adjusted to produce maximum available for end user RF output power.

7.6.2.3 The spurious emission was measured with spectrum analyzer as provided in Table 7.6.2 and associated plots.

Figure 7.6.1 Spurious emission test setup

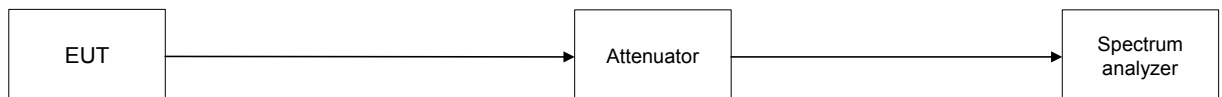





<b>Test specification: Section 96.41(e)(3), Conducted spurious emissions</b>			
<b>Test procedure:</b> Section 96.41(e)(3)			
<b>Test mode:</b> Compliance		<b>Verdict: PASS</b>	
<b>Date(s):</b> 23-Dec-18			
<b>Temperature:</b> 24.3 °C	<b>Relative Humidity:</b> 48 %	<b>Air Pressure:</b> 1009 hPa	<b>Power:</b> 48 VDC
<b>Remarks:</b>			

**Table 7.6.2 Spurious emission test results**

ASSIGNED FREQUENCY RANGE: 3550 - 3700 MHz  
 INVESTIGATED FREQUENCY RANGE: 0.009 – 37000 MHz  
 DETECTOR USED: Peak  
 VIDEO BANDWIDTH: ≥ Resolution bandwidth  
 MODULATION: QPSK  
 MODULATING SIGNAL: PRBS  
 CHANNEL SPACING: 10 MHz  
 TRANSMITTER OUTPUT POWER SETTINGS: Maximum

Frequency, MHz	SA reading, dBm	Attenuator, dB	Cable loss, dB	RBW, kHz	Spurious emission, dBm	Attenuation below carrier, dBc	Limit, dBc	Margin, dB*	Verdict
<b>Low carrier frequency 3555 MHz</b>									
No emissions were found									Pass
<b>Mid carrier frequency 3625 MHz</b>									
No emissions were found									Pass
<b>High carrier frequency 3695 MHz</b>									
No emissions were found									Pass

\*- Margin = Spurious emission – specification limit.

Note: in 0.009-18000 MHz range the offset 31.6 dB included: attenuator 30 dB, cables loss 1.6 dB  
in 18-37 GHz range the offset 32.9 dB included: attenuator 30 dB, cables loss 2.9 dB

**Reference numbers of test equipment used**

HL 4355	HL 3818	HL 3903	HL 3434	HL 4366	HL 5286
HL 3287	HL 4342	HL 5174	HL 5175		

Full description is given in Appendix A.



<b>Test specification: Section 96.41(e)(3), Conducted spurious emissions</b>			
Test procedure: Section 96.41(e)(3)			
Test mode: Compliance		Verdict: PASS	
Date(s): 23-Dec-18			
Temperature: 24.3 °C	Relative Humidity: 48 %	Air Pressure: 1009 hPa	Power: 48 VDC
Remarks:			

Plot 7.6.1 Spurious emission measurements in 9 - 150 kHz range at low carrier frequency

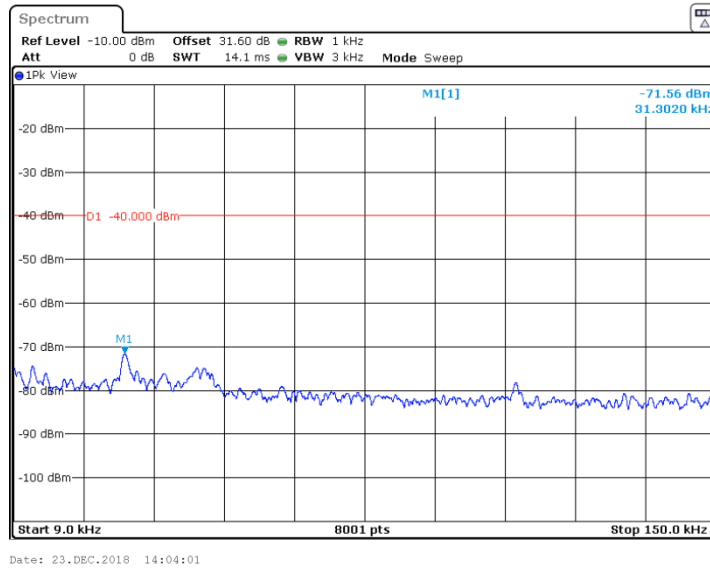

Plot 7.6.2 Spurious emission measurements in 9 - 150 kHz range at mid carrier frequency

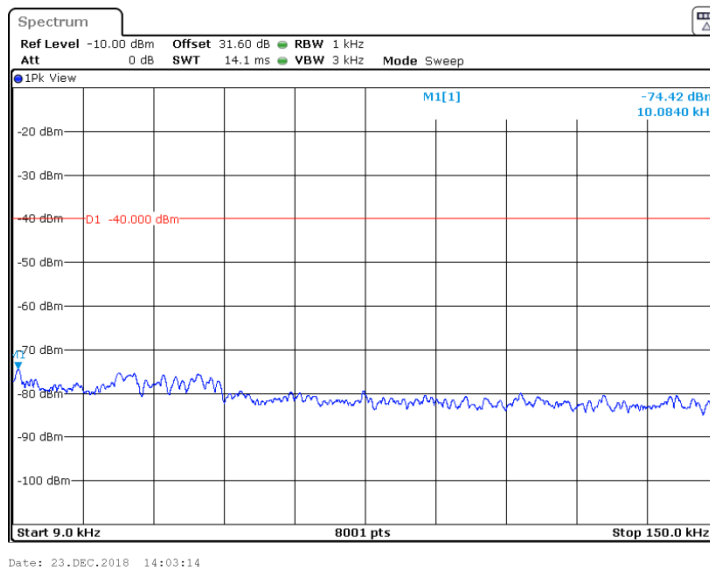



<b>Test specification: Section 96.41(e)(3), Conducted spurious emissions</b>			
<b>Test procedure:</b> Section 96.41(e)(3)			
<b>Test mode:</b> Compliance		<b>Verdict: PASS</b>	
<b>Date(s):</b> 23-Dec-18			
<b>Temperature:</b> 24.3 °C	<b>Relative Humidity:</b> 48 %	<b>Air Pressure:</b> 1009 hPa	<b>Power:</b> 48 VDC
<b>Remarks:</b>			

Plot 7.6.3 Spurious emission measurements in 9 - 150 kHz range at high carrier frequency

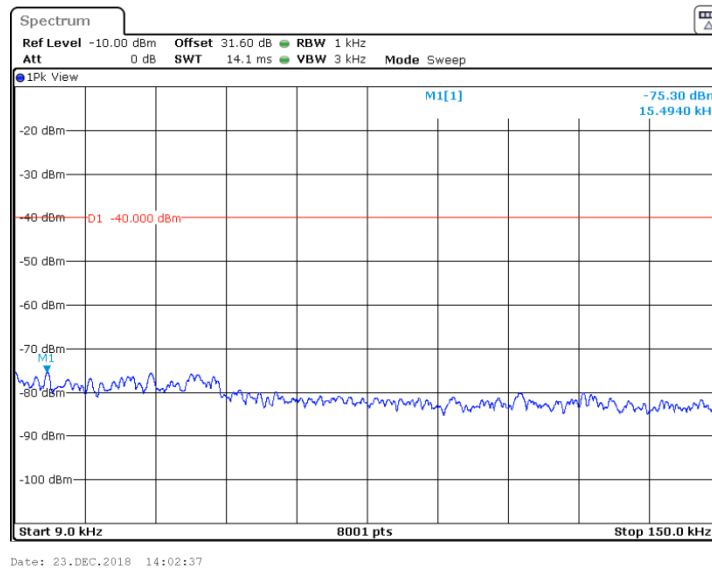

Plot 7.6.4 Spurious emission measurements in 0.15 – 1 MHz range at low carrier frequency

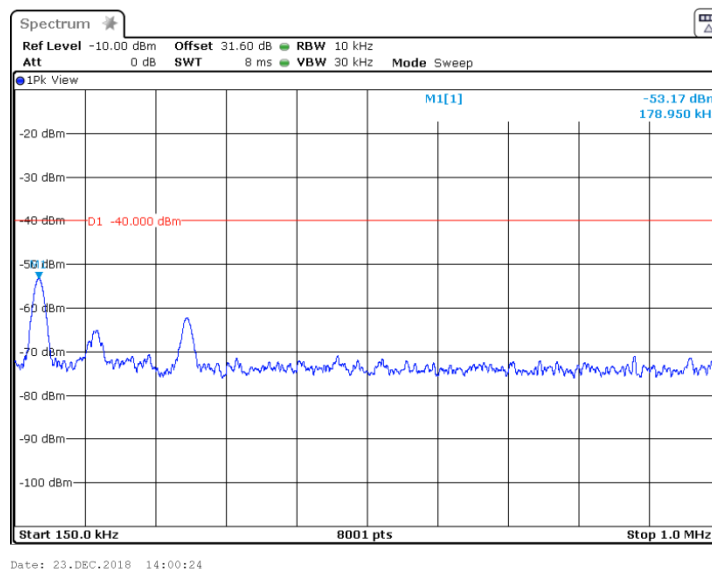



<b>Test specification: Section 96.41(e)(3), Conducted spurious emissions</b>			
<b>Test procedure:</b> Section 96.41(e)(3)			
<b>Test mode:</b> Compliance		<b>Verdict: PASS</b>	
<b>Date(s):</b> 23-Dec-18			
<b>Temperature:</b> 24.3 °C	<b>Relative Humidity:</b> 48 %	<b>Air Pressure:</b> 1009 hPa	<b>Power:</b> 48 VDC
<b>Remarks:</b>			

Plot 7.6.5 Spurious emission measurements in 0.15 - 1MHz range at mid carrier frequency

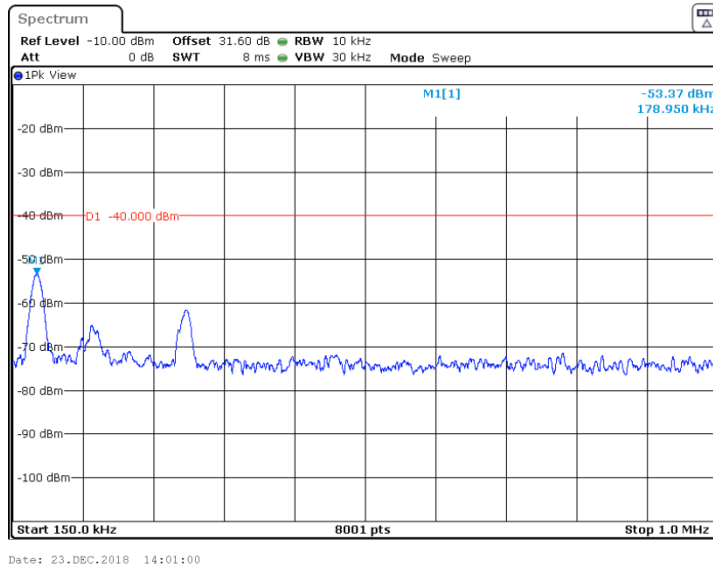

Plot 7.6.6 Spurious emission measurements in 0.15 - 1MHz range at high carrier frequency

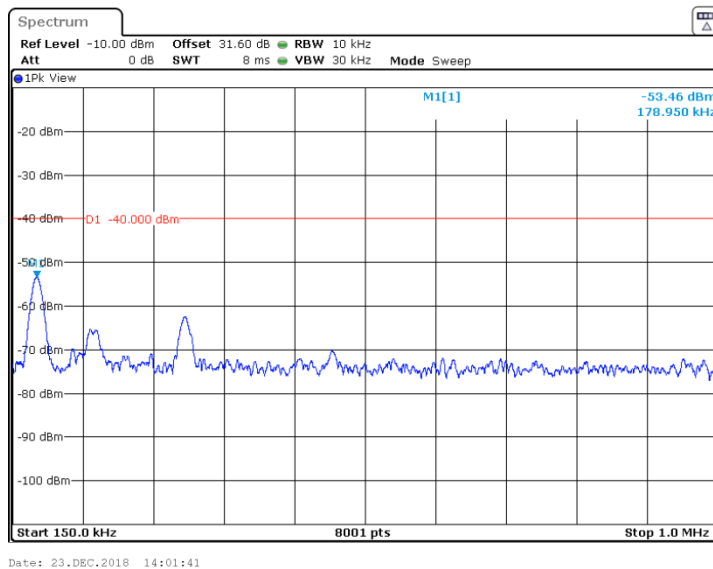



<b>Test specification: Section 96.41(e)(3), Conducted spurious emissions</b>			
<b>Test procedure:</b> Section 96.41(e)(3)			
<b>Test mode:</b> Compliance		<b>Verdict:</b> PASS	
<b>Date(s):</b> 23-Dec-18			
<b>Temperature:</b> 24.3 °C	<b>Relative Humidity:</b> 48 %	<b>Air Pressure:</b> 1009 hPa	<b>Power:</b> 48 VDC
<b>Remarks:</b>			

Plot 7.6.7 Spurious emission measurements in 1- 30.0 MHz range at low carrier frequency

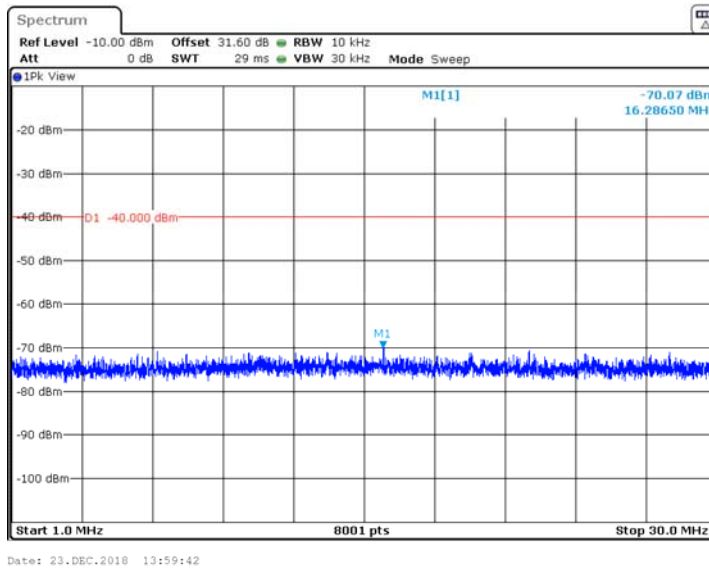

Plot 7.6.8 Spurious emission measurements in 1- 30.0 MHz range at mid carrier frequency

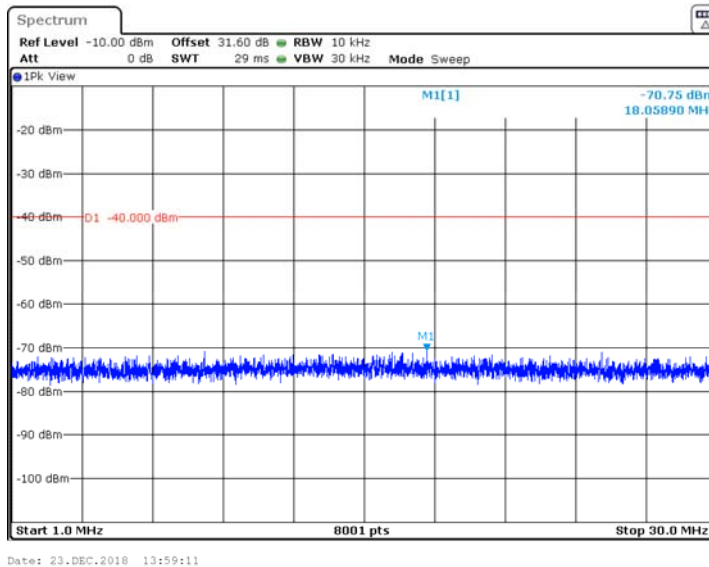



<b>Test specification: Section 96.41(e)(3), Conducted spurious emissions</b>			
<b>Test procedure:</b> Section 96.41(e)(3)			
<b>Test mode:</b> Compliance		<b>Verdict: PASS</b>	
<b>Date(s):</b> 23-Dec-18			
<b>Temperature:</b> 24.3 °C	<b>Relative Humidity:</b> 48 %	<b>Air Pressure:</b> 1009 hPa	<b>Power:</b> 48 VDC
<b>Remarks:</b>			

Plot 7.6.9 Spurious emission measurements in 1 – 30.0 MHz range at high carrier frequency

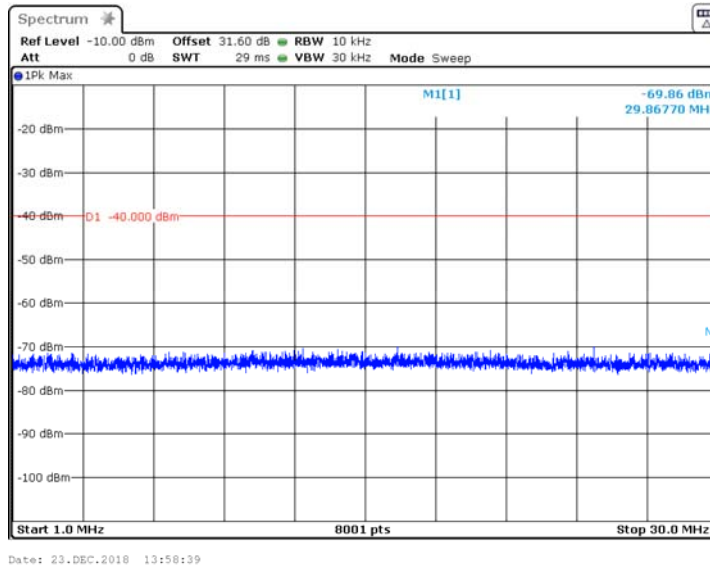

Plot 7.6.10 Spurious emission measurements in 30.0 - 1000 MHz range at low carrier frequency

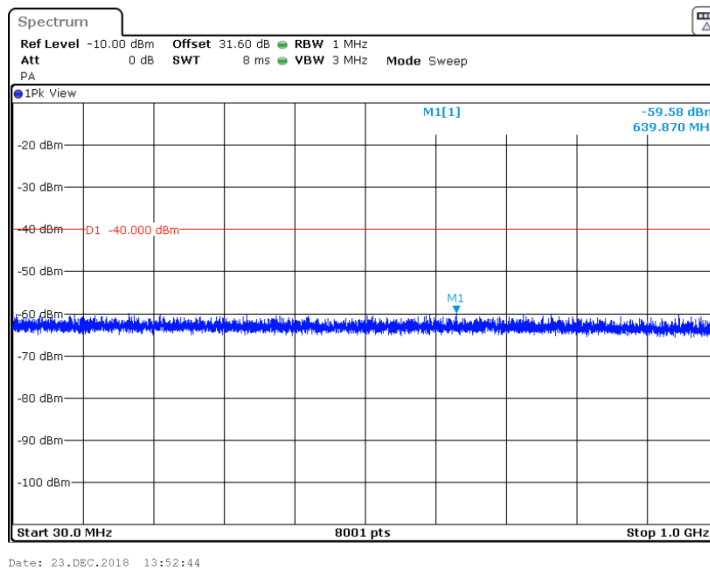



<b>Test specification: Section 96.41(e)(3), Conducted spurious emissions</b>			
<b>Test procedure:</b> Section 96.41(e)(3)			
<b>Test mode:</b> Compliance		<b>Verdict: PASS</b>	
<b>Date(s):</b> 23-Dec-18			
<b>Temperature:</b> 24.3 °C	<b>Relative Humidity:</b> 48 %	<b>Air Pressure:</b> 1009 hPa	<b>Power:</b> 48 VDC
<b>Remarks:</b>			

Plot 7.6.11 Spurious emission measurements in 30.0 - 1000 MHz range at mid carrier frequency

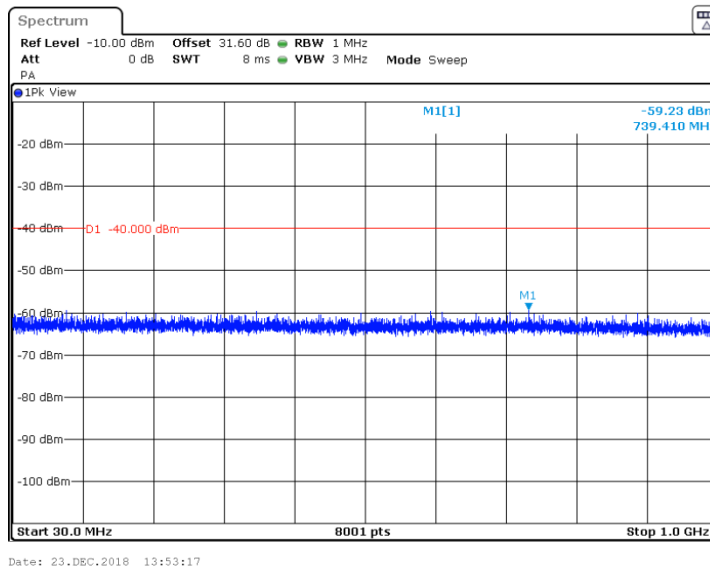

Plot 7.6.12 Spurious emission measurements in 30.0 - 1000 MHz range at high carrier frequency

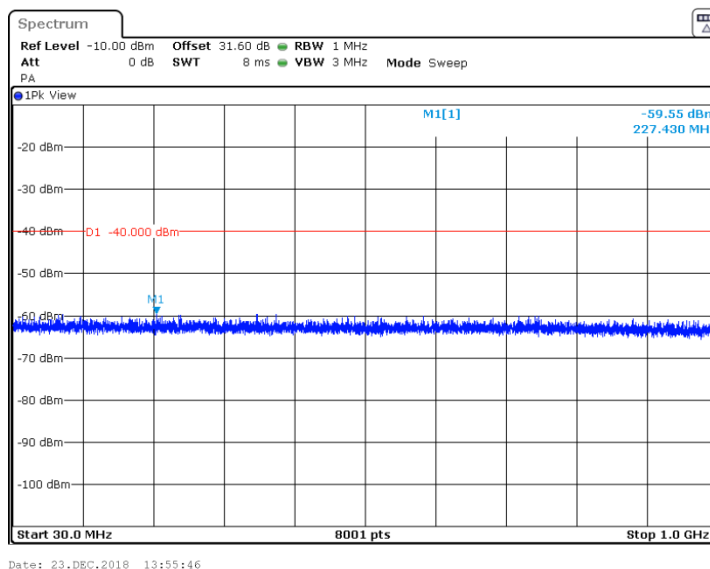



<b>Test specification: Section 96.41(e)(3), Conducted spurious emissions</b>			
<b>Test procedure:</b> Section 96.41(e)(3)			
<b>Test mode:</b> Compliance		<b>Verdict: PASS</b>	
<b>Date(s):</b> 23-Dec-18			
<b>Temperature:</b> 24.3 °C	<b>Relative Humidity:</b> 48 %	<b>Air Pressure:</b> 1009 hPa	<b>Power:</b> 48 VDC
<b>Remarks:</b>			

Plot 7.6.13 Spurious emission measurements in 1000 - 3500 MHz range at low carrier frequency

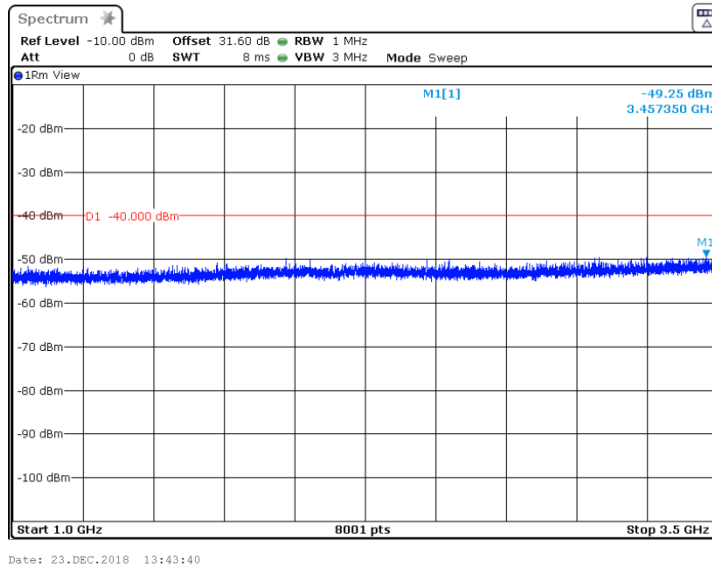

Plot 7.6.14 Spurious emission measurements in 1000 - 3500 MHz at mid carrier frequency

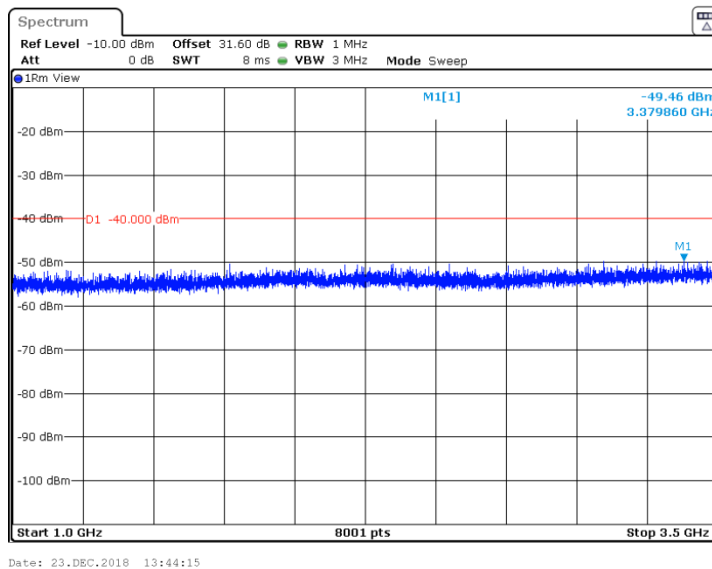





<b>Test specification: Section 96.41(e)(3), Conducted spurious emissions</b>			
<b>Test procedure:</b> Section 96.41(e)(3)			
<b>Test mode:</b> Compliance		<b>Verdict: PASS</b>	
<b>Date(s):</b> 23-Dec-18			
<b>Temperature:</b> 24.3 °C	<b>Relative Humidity:</b> 48 %	<b>Air Pressure:</b> 1009 hPa	<b>Power:</b> 48 VDC
<b>Remarks:</b>			

Plot 7.6.15 Spurious emission measurements in 1000 - 3500 MHz at high carrier frequency

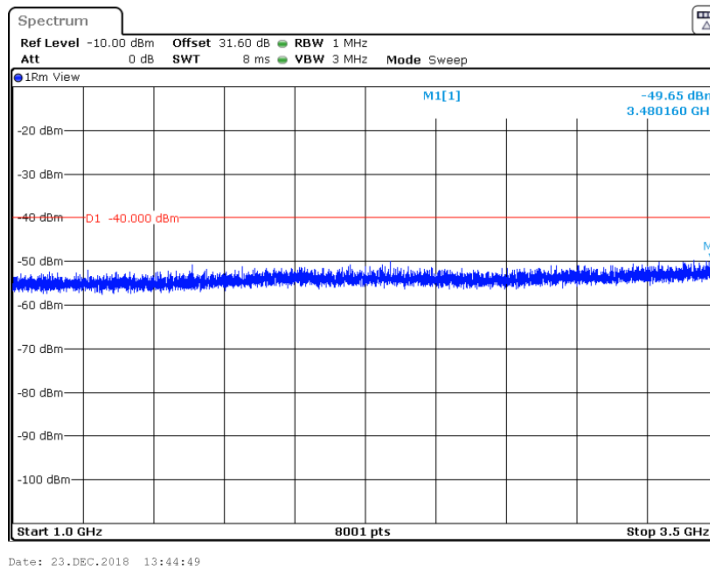

Plot 7.6.16 Spurious emission measurements in 3500 - 3530 MHz range at low carrier frequency

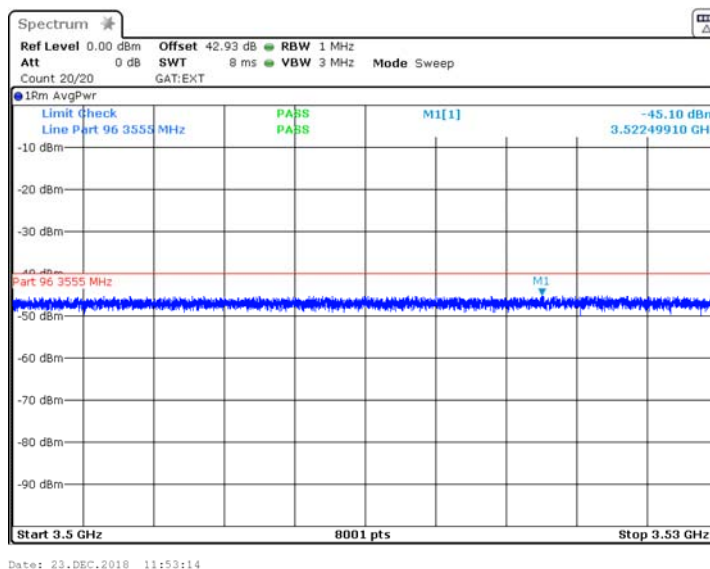



<b>Test specification: Section 96.41(e)(3), Conducted spurious emissions</b>			
<b>Test procedure:</b> Section 96.41(e)(3)			
<b>Test mode:</b> Compliance		<b>Verdict: PASS</b>	
<b>Date(s):</b> 23-Dec-18			
<b>Temperature:</b> 24.3 °C	<b>Relative Humidity:</b> 48 %	<b>Air Pressure:</b> 1009 hPa	<b>Power:</b> 48 VDC
<b>Remarks:</b>			

Plot 7.6.17 Spurious emission measurements in 3500 - 3600 MHz at mid carrier frequency

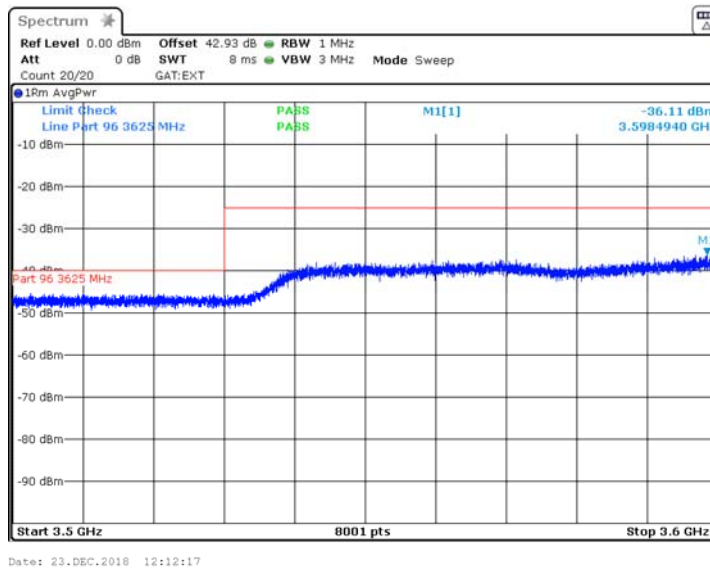

Plot 7.6.18 Spurious emission measurements in 3500 - 3680 MHz at high carrier frequency

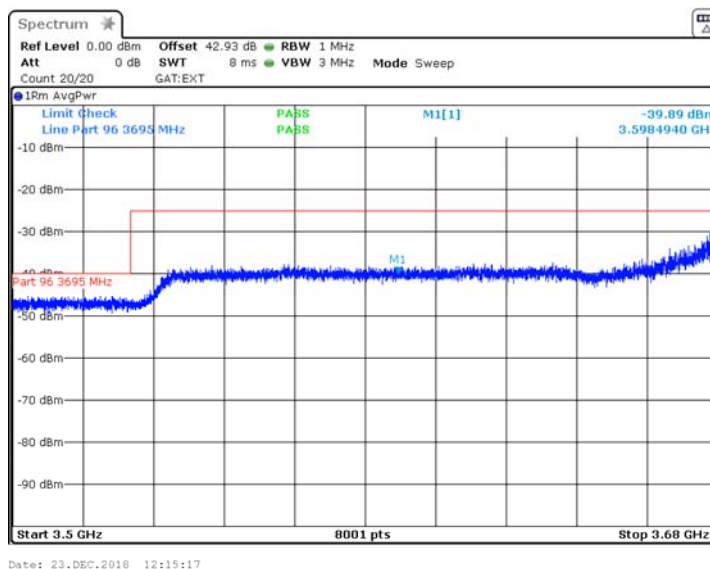



<b>Test specification: Section 96.41(e)(3), Conducted spurious emissions</b>			
<b>Test procedure:</b> Section 96.41(e)(3)			
<b>Test mode:</b> Compliance		<b>Verdict: PASS</b>	
<b>Date(s):</b> 23-Dec-18			
<b>Temperature:</b> 24.3 °C	<b>Relative Humidity:</b> 48 %	<b>Air Pressure:</b> 1009 hPa	<b>Power:</b> 48 VDC
<b>Remarks:</b>			

Plot 7.6.19 Spurious emission measurements in 3580 - 3800 MHz range at low carrier frequency

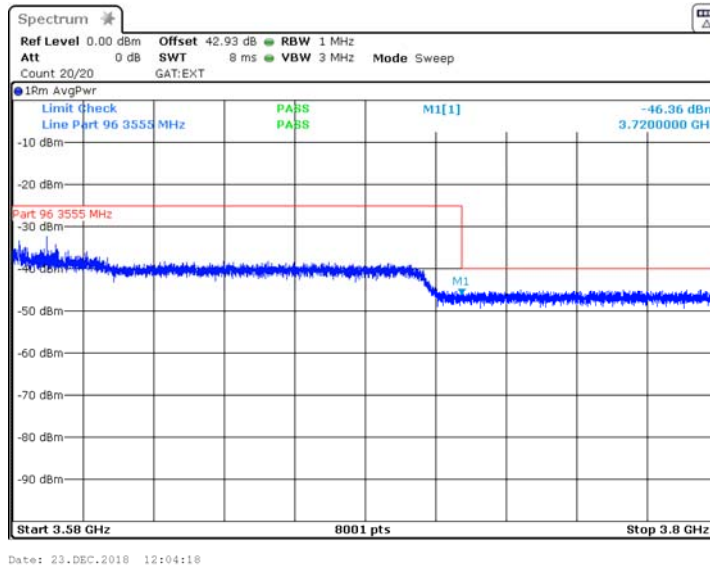

Plot 7.6.20 Spurious emission measurements in 3650 - 3800 MHz range at mid carrier frequency

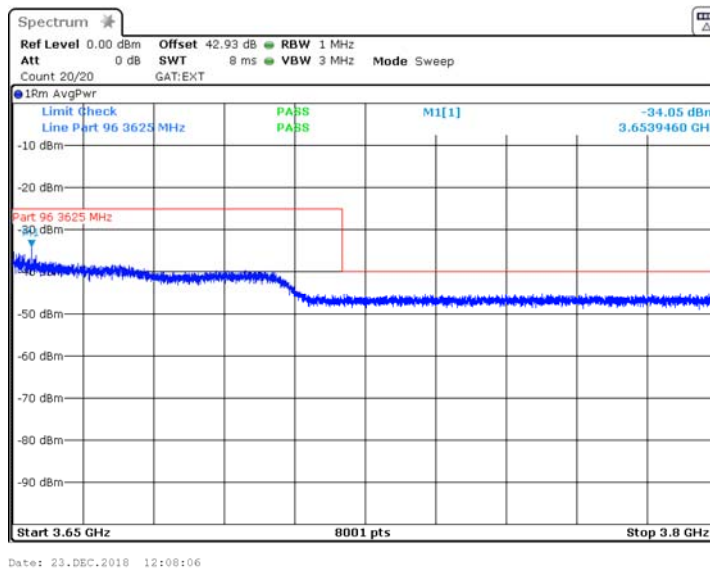



<b>Test specification: Section 96.41(e)(3), Conducted spurious emissions</b>			
<b>Test procedure:</b> Section 96.41(e)(3)			
<b>Test mode:</b> Compliance		<b>Verdict: PASS</b>	
<b>Date(s):</b> 23-Dec-18			
<b>Temperature:</b> 24.3 °C	<b>Relative Humidity:</b> 48 %	<b>Air Pressure:</b> 1009 hPa	<b>Power:</b> 48 VDC
<b>Remarks:</b>			

Plot 7.6.21 Spurious emission measurements in 3720 – 3800 MHz range at high carrier frequency

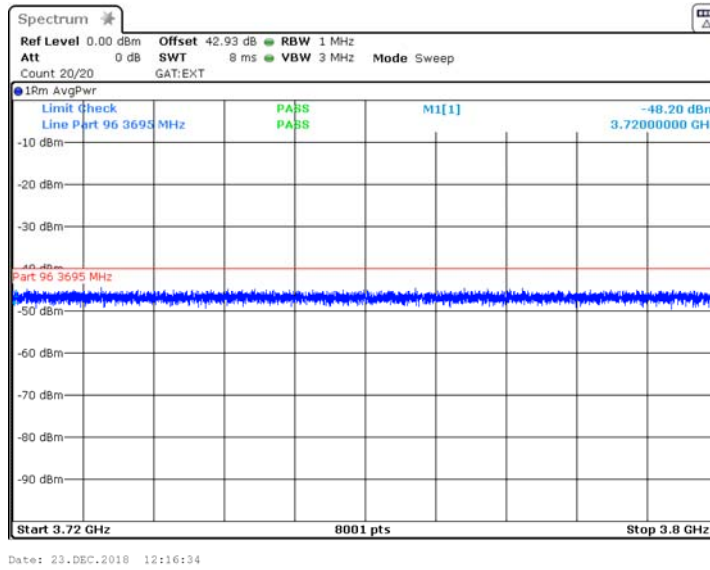

Plot 7.6.22 Spurious emission measurements in 3800 - 6000 MHz range at low carrier frequency

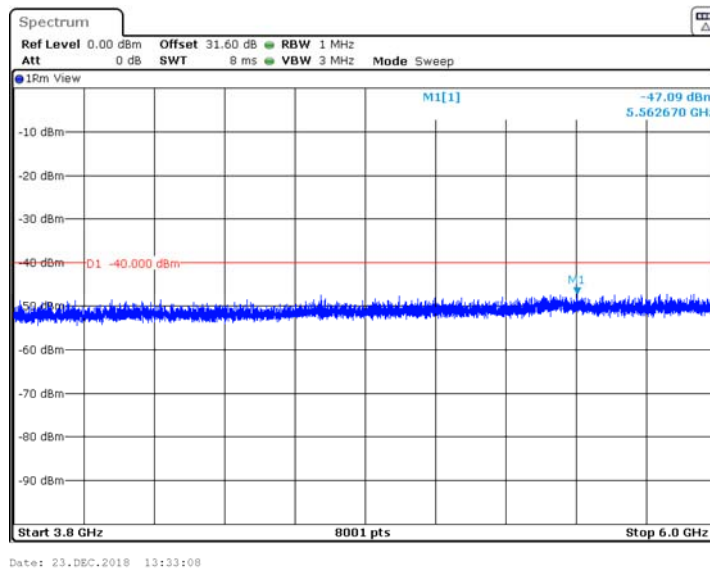



<b>Test specification: Section 96.41(e)(3), Conducted spurious emissions</b>			
<b>Test procedure:</b> Section 96.41(e)(3)			
<b>Test mode:</b> Compliance		<b>Verdict:</b> PASS	
<b>Date(s):</b> 23-Dec-18			
<b>Temperature:</b> 24.3 °C	<b>Relative Humidity:</b> 48 %	<b>Air Pressure:</b> 1009 hPa	<b>Power:</b> 48 VDC
<b>Remarks:</b>			

Plot 7.6.23 Spurious emission measurements in 3800 - 6000 MHz at mid carrier frequency

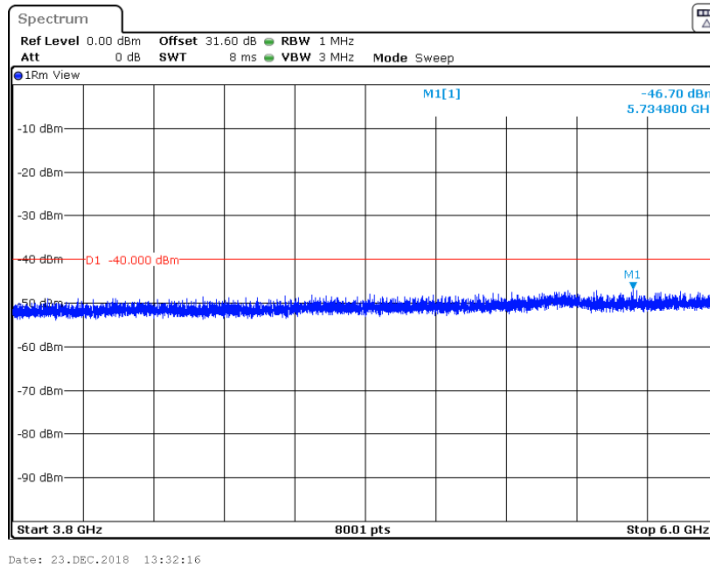

Plot 7.6.24 Spurious emission measurements in 3800 - 6000 MHz at high carrier frequency

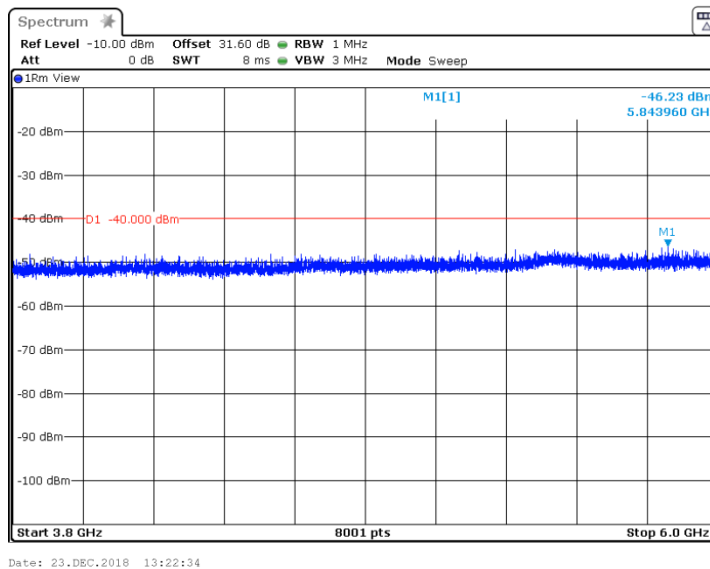



<b>Test specification: Section 96.41(e)(3), Conducted spurious emissions</b>			
<b>Test procedure:</b> Section 96.41(e)(3)			
<b>Test mode:</b> Compliance		<b>Verdict: PASS</b>	
<b>Date(s):</b> 23-Dec-18			
<b>Temperature:</b> 24.3 °C	<b>Relative Humidity:</b> 48 %	<b>Air Pressure:</b> 1009 hPa	<b>Power:</b> 48 VDC
<b>Remarks:</b>			

Plot 7.6.25 Spurious emission measurements in 18000 - 26500 MHz range at low carrier frequency

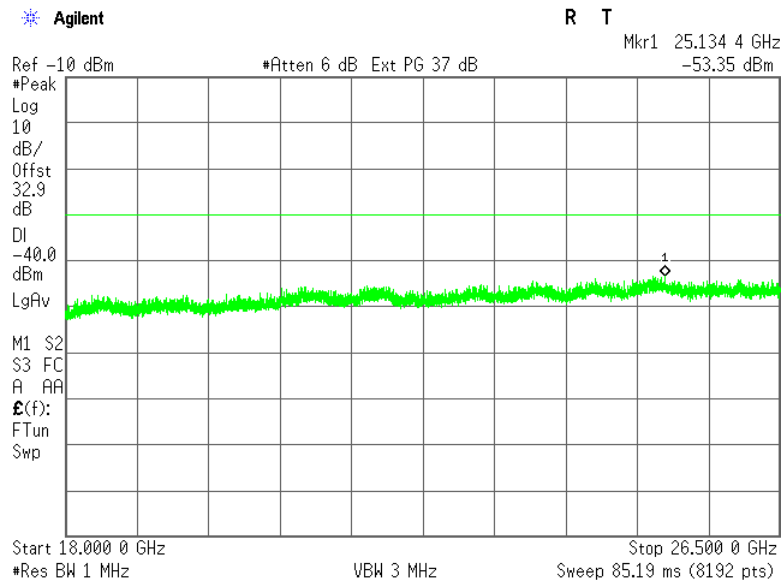

Plot 7.6.26 Spurious emission measurements in 18000 - 26500 MHz at mid carrier frequency

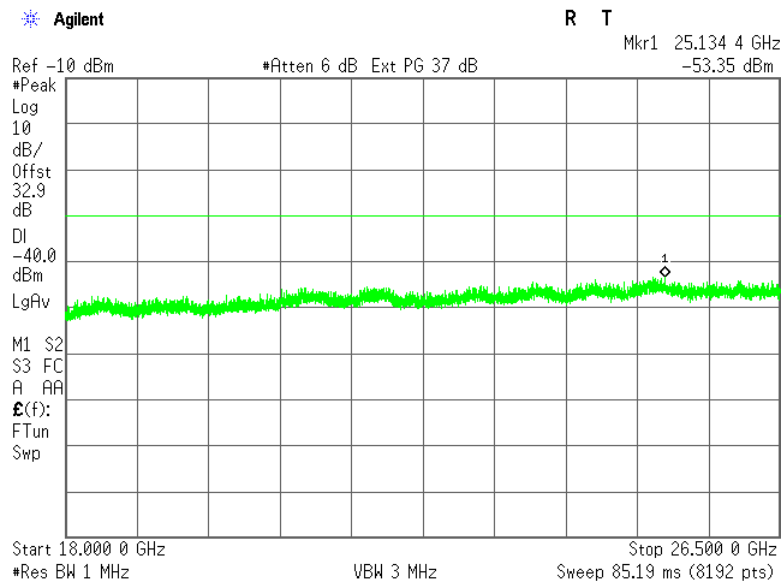



<b>Test specification: Section 96.41(e)(3), Conducted spurious emissions</b>			
<b>Test procedure:</b> Section 96.41(e)(3)			
<b>Test mode:</b> Compliance		<b>Verdict: PASS</b>	
<b>Date(s):</b> 23-Dec-18			
<b>Temperature:</b> 24.3 °C	<b>Relative Humidity:</b> 48 %	<b>Air Pressure:</b> 1009 hPa	<b>Power:</b> 48 VDC
<b>Remarks:</b>			

Plot 7.6.27 Spurious emission measurements in 18000 - 26500 MHz at high carrier frequency

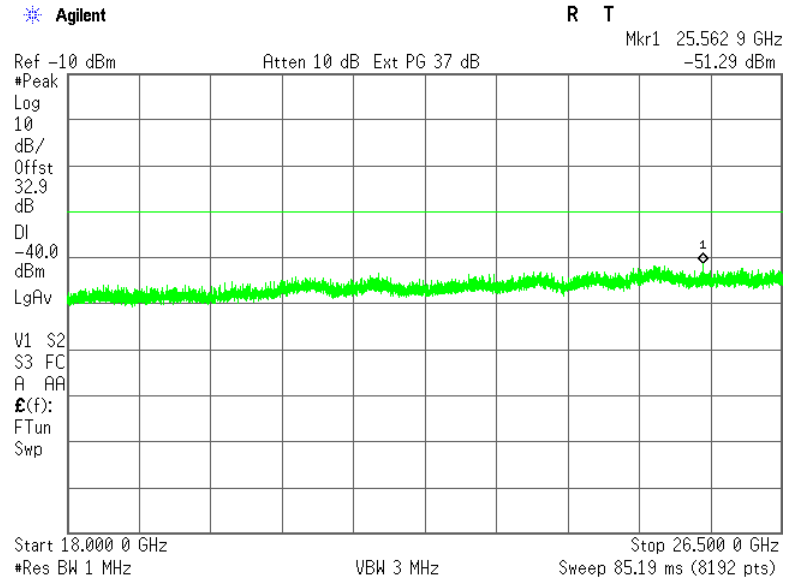

Plot 7.6.28 Spurious emission measurements in 26500 - 37000 MHz range at low carrier frequency

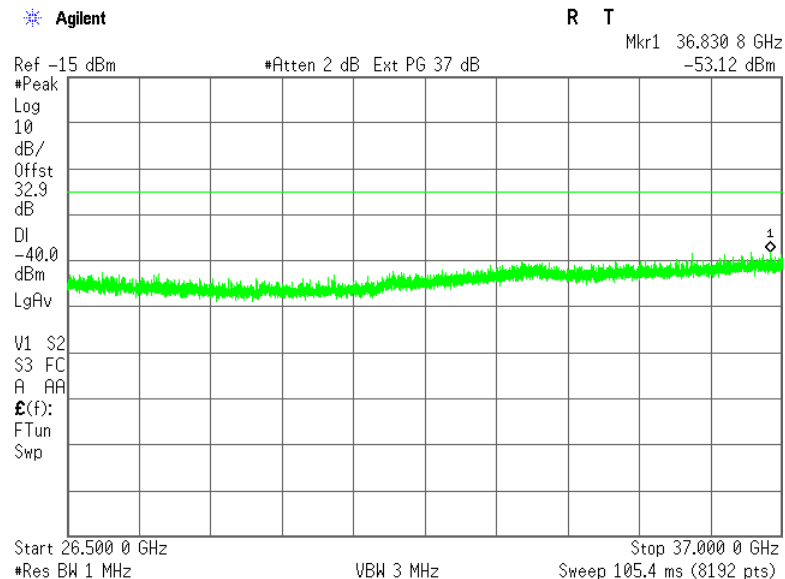



<b>Test specification: Section 96.41(e)(3), Conducted spurious emissions</b>			
<b>Test procedure:</b> Section 96.41(e)(3)			
<b>Test mode:</b> Compliance		<b>Verdict: PASS</b>	
<b>Date(s):</b> 23-Dec-18			
<b>Temperature:</b> 24.3 °C	<b>Relative Humidity:</b> 48 %	<b>Air Pressure:</b> 1009 hPa	<b>Power:</b> 48 VDC
<b>Remarks:</b>			

Plot 7.6.29 Spurious emission measurements in 26500 - 37000 MHz at mid carrier frequency

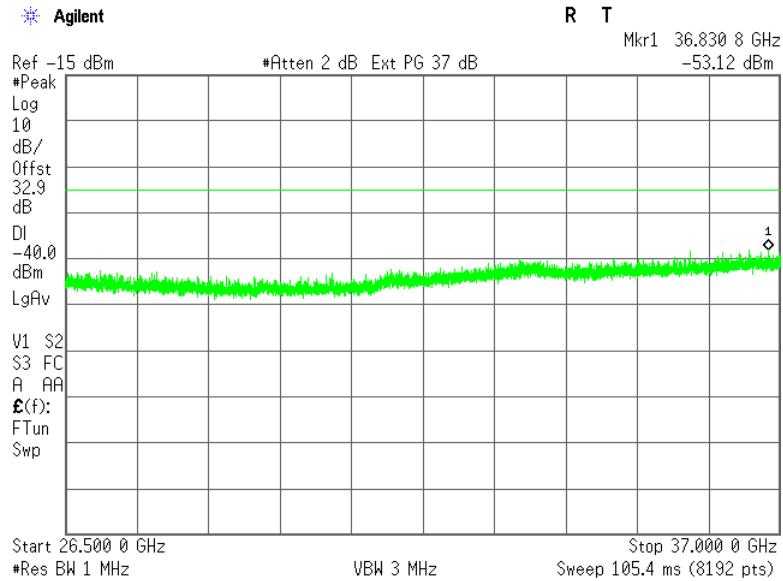

Plot 7.6.30 Spurious emission measurements in 26500 - 37000 MHz at high carrier frequency

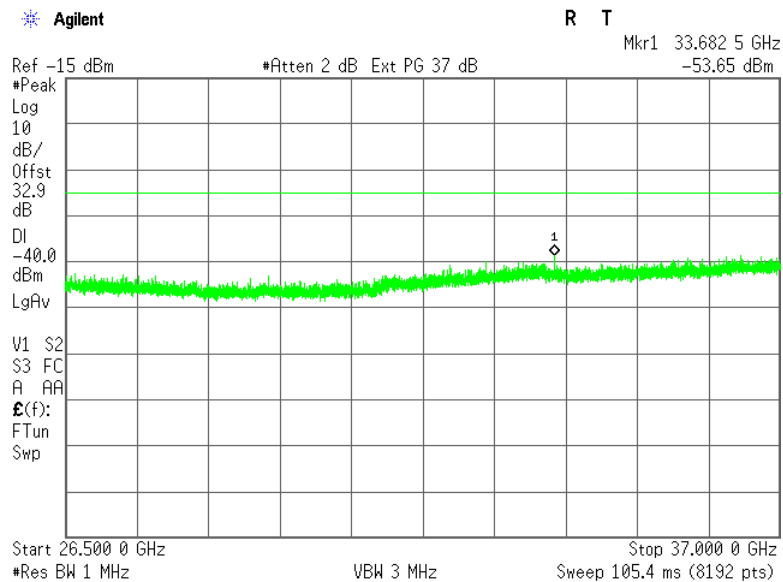





<b>Test specification: Section 2.1055, Frequency stability</b>			
<b>Test procedure:</b> 47 CFR, Section 2.1055			
<b>Test mode:</b> Compliance		<b>Verdict: PASS</b>	
<b>Date(s):</b> 03-Jan-19			
<b>Temperature:</b> 23 °C	<b>Relative Humidity:</b> 55 %	<b>Air Pressure:</b> 1008 hPa	<b>Power:</b> 48 VDC
<b>Remarks:</b>			

## 7.7 Frequency stability test

### 7.7.1 General

This test was performed to measure frequency stability of transmitter RF carrier. Specification test limits are given in Table 7.7.1.

Table 7.7.1 Frequency stability limits

Assigned frequency, MHz	Maximum allowed frequency displacement	
	ppm	Hz
3555.0	NA	NA
3625.0		NA
3695.0		NA

### 7.7.2 Test procedure

- 7.7.2.1 The EUT was set up as shown in Figure 7.7.1, energized and its proper operation was checked.
- 7.7.2.2 The EUT power was turned off. Temperature within test chamber was set to +30°C and a period of time sufficient to stabilize all of the oscillator circuit components was allowed.
- 7.7.2.3 The EUT was powered on and carrier frequency was measured at start up moment and then every minute until frequency had been stabilized or 10 minutes elapsed whichever reached the last. The EUT was powered off.
- 7.7.2.4 The above procedure was repeated at 0°C and at the lowest test temperature.
- 7.7.2.5 The EUT was powered on and carrier frequency was measured at start up moment and at the end of stabilization period at the rest of test temperatures and voltages. The EUT was powered off.
- 7.7.2.6 Frequency displacement was calculated and compared with the limit as provided in Table 7.7.2.

Figure 7.7.1 Frequency stability test setup

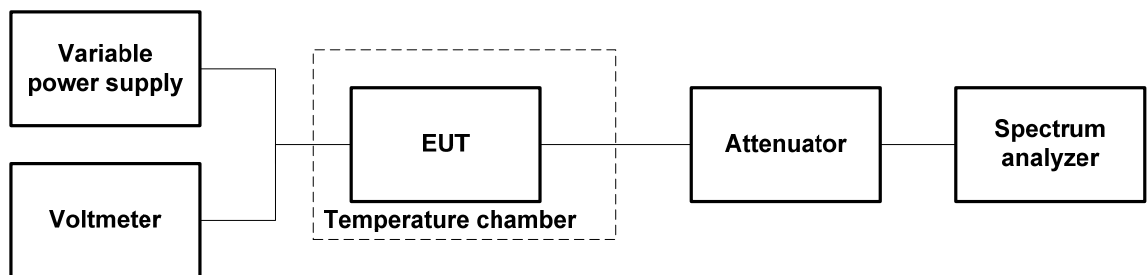



HERMON LABORATORIES

<b>Test specification: Section 2.1055, Frequency stability</b>			
<b>Test procedure:</b> 47 CFR, Section 2.1055			
<b>Test mode:</b> Compliance		<b>Verdict: PASS</b>	
<b>Date(s):</b> 03-Jan-19			
<b>Temperature:</b> 23 °C	<b>Relative Humidity:</b> 55 %	<b>Air Pressure:</b> 1008 hPa	<b>Power:</b> 48 VDC
<b>Remarks:</b>			

Table 7.7.2 Frequency stability test results

OPERATING FREQUENCY: 3550 – 3700 MHz  
 NOMINAL POWER VOLTAGE: 48 VDC  
 TEMPERATURE STABILIZATION PERIOD: 20 min  
 POWER DURING TEMPERATURE TRANSITION: Off  
 SPECTRUM ANALYZER MODE: Counter  
 RESOLUTION BANDWIDTH: 1 kHz  
 VIDEO BANDWIDTH: 1 kHz  
 MODULATION: Unmodulated

T, °C	Voltage, V	Frequency, MHz							Max frequency drift, Hz		Verdict
		Start up	1 <sup>st</sup> min	2 <sup>nd</sup> min	3 <sup>rd</sup> min	4 <sup>th</sup> min	5 <sup>th</sup> min	10 <sup>th</sup> min	Positive	Negative	
<b>Low frequency 3555.0 MHz</b>											
-30	nominal	3555.00050	3555.00050	3555.00050	3555.00045	3555.00050	3555.00050	3555.00045	500	0	Comply
-20	nominal	3555.00055	NA	NA	NA	NA	NA	3555.00055	550	0	Comply
-10	nominal	3555.00055	NA	NA	NA	NA	NA	3555.00055	550	0	Comply
0	nominal	3555.0005	3555.00055	3555.00050	3555.00035	3555.00040	3555.00050	3555.00050	550	0	Comply
10	nominal	3555.00050	NA	NA	NA	NA	NA	3555.00045	500	0	Comply
20	15%	3554.99947	NA	NA	NA	NA	NA	3554.99922	0	-777	Comply
20	nominal	3554.99932	NA	NA	NA	NA	NA	3554.99889	0	-1114	Comply
20	-15%	3554.99932	NA	NA	NA	NA	NA	3554.99886	0	-1136	Comply
30	nominal	3554.99816	3555.00020	3555.00024	3555.00015	3555.00019	3555.00017	3555.00019	242	-1841	Comply
40	nominal	3554.99950	NA	NA	NA	NA	NA	3555.00055	550	-500	Comply
50	nominal	3555.00055	NA	NA	NA	NA	NA	3555.00050	550	0	Comply
<b>Mid frequency 3625.0 MHz</b>											
-30	nominal	3625.00055	3625.0005	3625.0005	3625.00055	3625.0005	3625.00045	3625.00045	550	0	Comply
-20	nominal	3625.00055	NA	NA	NA	NA	NA	3625.00045	550	0	Comply
-10	nominal	3624.99950	NA	NA	NA	NA	NA	3625.00055	550	-450	Comply
0	nominal	3625.00060	3625.00055	3625.0005	3625.00055	3625.0006	3625.0006	3625.0006	600	0	Comply
10	nominal	3625.00045	NA	NA	NA	NA	NA	3625.00045	450	0	Comply
20	15%	3624.99916	NA	NA	NA	NA	NA	3624.99929	0	-838	Comply
20	nominal	3624.99931	NA	NA	NA	NA	NA	3624.99948	0	-693	Comply
20	-15%	3624.99913	NA	NA	NA	NA	NA	3624.99926	0	-868	Comply
30	nominal	3624.99989	3625.00013	3625.00016	3625.00010	3625.00013	3625.00011	3625.00013	164	-110	Comply
40	nominal	3625.0005	NA	NA	NA	NA	NA	3625.0006	600	0	Comply
50	nominal	3625.00055	NA	NA	NA	NA	NA	3625.0004	550	0	Comply
<b>High frequency 3695.0 MHz</b>											
-30	nominal	3695.0005	3695.00050	3695.00055	3695.00055	3695.00055	3695.00055	3695.00055	550	0	Comply
-20	nominal	3695.00045	NA	NA	NA	NA	NA	3695.00055	550	0	Comply
-10	nominal	3695.00050	NA	NA	NA	NA	NA	3695.0006	600	0	Comply
0	nominal	3695.00045	3695.00045	3695.0005	3695.00055	3695.00055	3695.00055	3695.00055	550	0	Comply
10	nominal	3695.00040	NA	NA	NA	NA	NA	3695.00055	550	0	Comply
20	15%	3694.99921	NA	NA	NA	NA	NA	3694.99947	0	-793	Comply
20	nominal	3694.99921	NA	NA	NA	NA	NA	3694.99954	0	-337	Comply
20	-15%	3694.99951	NA	NA	NA	NA	NA	3694.99940	0	-598	Comply
30	nominal	3694.99905	3694.99928	3695.00021	3695.00017	3695.00018	3695.00016	3695.00012	210	-720	Comply
40	nominal	3695.00045	NA	NA	NA	NA	NA	3695.00045	450	0	Comply
50	nominal	3695.00045	NA	NA	NA	NA	NA	3695.0004	450	0	Comply

\* - Reference frequency

Reference numbers of test equipment used

HL 2909	HL 2358	HL 5391					
---------	---------	---------	--	--	--	--	--

Full description is given in Appendix A.

**8 APPENDIX A Test equipment and ancillaries used for tests**

HL No	Description	Manufacturer	Model	Ser. No.	Last Cal./ Check	Due Cal./ Check
0446	Antenna, Loop, Active, 9 kHz - 30 MHz	EMCO	6502	2857	24-Feb-19	24-Feb-20
2358	Power Supply, 2 X 0-36VDC / 5A, 5VDC / 5A	Horizon Electronics	DHR3655 D	767469	03-Jun-18	03-Jun-19
2909	Spectrum analyzer, ESA-E, 100 Hz to 26.5 GHz	Agilent Technologies	E4407B	MY414447 62	27-Mar-18	27-Mar-19
3287	Low pass filter, DC-3.0 GHz	Unknown	NA	3287	01-Oct-17	01-Oct-19
3301	Power Meter, P-series, 50 MHz to 40 GHz	Agilent Technologies	N1911A	MY451010 57	02-May-18	02-May-19
3302	Power sensor, P-Series, 50 MHz to 40 GHz, -35/30 to 20 dBm	Agilent Technologies	N1922A	MY452405 86	02-May-18	02-May-19
3433	Test Cable , DC-18 GHz, 1.5 m, SMA - SMA	Mini-Circuits	CBL-5FT-SMSM+	25679	28-Mar-18	28-Mar-19
3434	Test Cable , DC-18 GHz, 1.5 m, SMA - SMA	Mini-Circuits	CBL-5FT-SMSM+	25683	28-Mar-18	28-Mar-19
3818	PSA Series Spectrum Analyzer, 3 Hz- 44 GHz	Agilent Technologies	E4446A	MY482502 88	28-May-18	28-May-19
3903	Microwave Cable Assembly, 40.0 GHz, 1.5 m, SMA/SMA	Huber-Suhner	SUCOFLE X 102A	1226/2A	07-Feb-18	07-Mar-19
4342	High Pass Filter, 50 Ohm, 10.6 to 26.5 GHz,SMA-M / SMA-FM	RLC Electronics	F-5738A	8425	17-May-18	17-May-19
4355	Signal and Spectrum Analyzer, 9 kHz to 7 GHz	Rohde & Schwarz	FSV 7	101630	28-Jun-18	28-Sep-19
4360	EMI Test Receiver, 20 Hz to 40 GHz.	Rohde & Schwarz	ESU40	100322	31-Dec-18	31-Dec-19
4366	Directional coupler, 1 GHz to 18 GHz, 10 dB, SMA Female	Tiger Micro-Electronics Institute	TGD-A1101-10	01e-JSDE805-007	21-May-18	21-May-20
4933	Active Horn Antenna, 1 GHz to 18 GHz	Com-Power Corporation	AHA-118	701046	06-Jan-19	06-Jan-20
4956	Active horn antenna, 18 to 40 GHz	Com-Power Corporation	AHA-840	105004	25-Jan-19	25-Jan-20
5111	RF cable, 40 GHz, 5.5 m, K-type	Huber-Suhner	SF102EA/11SK/11S K/5500M M	502493/2E A	09-Apr-18	09-Apr-19
5174	Medium Power Fixed Coaxial Attenuator DC to 40 GHz, 10 dB, 5 W	API Weinschel, Inc	75A-10-12	TD854	07-Feb-18	07-Feb-19
5175	Medium Power Fixed Coaxial Attenuator DC to 40 GHz, 20 dB, 5 W	API Weinschel, Inc	75A-20-12	TE289	07-Feb-18	07-Feb-19
5286	Band Pass Filter, 50 Ohm, 4.4 to 18 GHz, SMA/M-SMA/F	A-INFOMW	WBLB-T-HP-4.4-18-S	J10800000 305	28-Mar-18	28-Mar-19
5288	Trilog Antenna, 25 MHz - 8 GHz, 100W	Frankonia	ALX-8000E	00809	08-Feb-19	08-Feb-22



HERMON LABORATORIES

HL No	Description	Manufacturer	Model	Ser. No.	Last Cal./ Check	Due Cal./ Check
5391	Temperature/Humidity Cycle Chamber, -77 - +177 deg., Humidity Range 20% RH to 95% RH	Thermotron	SM-8C	27737	22-Jul-18	22-Jul-19
5405	RF cable, 18 GHz, N-N, 6 m	Huber-Suhner	SF118/11 N(x2)	500023/118	01-Aug-18	01-Aug-19

**9 APPENDIX B Measurement uncertainties****Expanded uncertainty at 95% confidence in Hermon Labs EMC measurements**

Test description	Expanded uncertainty
<b>Transmitter tests</b>	
Carrier power conducted at antenna connector	± 1.7 dB
Carrier power radiated (substitution method)	± 4.5 dB
Occupied bandwidth	±8%
Conducted emissions at RF antenna connector	9 kHz to 2.9 GHz: ± 2.6 dB 2.9 GHz to 6.46 GHz: ± 3.5 dB 6.46 GHz to 13.2 GHz: ± 4.3 dB 13.2 GHz to 22.0 GHz: ± 5.0 dB 22.0 GHz to 26.8 GHz: ± 5.5 dB 26.8 GHz to 40.0 GHz: ± 4.8 dB
Spurious emissions radiated 30 MHz – 40 GHz (substitution method)	± 4.5 dB
Frequency error	30 – 300 MHz: ± 50.5 Hz (1.68 ppm) 300 – 1000 MHz: ± 168 Hz (0.56 ppm)
Transient frequency behaviour	187 Hz ± 13.9 %
Duty cycle, timing (Tx ON / OFF) and average factor measurements	± 1.0 %
<b>Unintentional radiator tests</b>	
Conducted emissions with LISN	9 kHz to 150 kHz: ± 3.9 dB 150 kHz to 30 MHz: ± 3.8 dB
Radiated emissions at 3 m measuring distance Horizontal polarization	Biconilog antenna: ± 5.3 dB Biconical antenna: ± 5.0 dB Log periodic antenna: ± 5.3 dB Double ridged horn antenna: ± 5.3 dB
Vertical polarization	Biconilog antenna: ± 6.0 dB Biconical antenna: ± 5.7 dB Log periodic antenna: ± 6.0 dB Double ridged horn antenna: ± 6.0 dB

Hermon Laboratories is accredited by A2LA for calibration according to present requirements of ISO/IEC 17025 and NCSL Z540-1. The accreditation is granted to perform calibration of parameters that are listed in the Scope of Hermon Laboratories Accreditation.

Hermon Laboratories calibrates its reference and transfer standards by calibration laboratories accredited to ISO/IEC 17025 by a mutually recognized Accreditation Body or by a recognized national metrology institute. All reference and transfer standards used in the calibration system are traceable to national or international standards.

In-house calibration of all test and measurement equipment is performed on a regular basis according to Hermon Laboratories calibration procedures, manufacturer calibration/verification procedures or procedures defined in the relevant standards. The Hermon Laboratories test and measurement equipment is calibrated within the tolerances specified by the manufacturers and/or by the relevant standards.

## 10 APPENDIX C Test facility description

Tests were performed at Hermon Laboratories Ltd., which is a fully independent, private, EMC, Radio, Safety, Environmental and Telecommunication testing facility.

Hermon Laboratories is recognized and accredited by the Federal Communications Commission (USA) for relevant parts of Code of Federal Regulations 47 (CFR 47), Test Firm Registration Number is 927748, Designation Number is IL1001; Recognized by Innovation, Science and Economic Development Canada for wireless and terminal testing (ISED), ISED #2186A, CAB identifier is IL1001; Certified by VCCI, Japan (the registration numbers are R-10808 for OATS, R-1082 for anechoic chamber, G-10869 for RE measurements above 1 GHz, C-10845 for conducted emissions site and T-11606 for conducted emissions at telecommunication ports).

The laboratory is accredited by American Association for Laboratory Accreditation (USA) according to ISO/IEC 17025 for electromagnetic compatibility, product safety, telecommunications testing, environmental simulation and calibration (for exact scope please refer to Certificate No. 839.01, 839.03 and 839.04).

Address: P.O. Box 23, Binyamina 3055001, Israel.  
Telephone: +972 4628 8001  
Fax: +972 4628 8277  
e-mail: mail@hermonlabs.com  
website: www.hermonlabs.com

Person for contact: Mr. Michael Nikishin, EMC&Radio group manager

## 11 APPENDIX D Specification references

FCC 47CFR part 96: 2017	Citizens Broadband Radio Service
FCC 47CFR part 1: 2017	Practice and procedure
FCC 47CFR part 2: 2017	Frequency allocations and radio treaty matters; general rules and regulations
ANSI C63.26:2015	American National Standard for Compliance Testing of Transmitters Used in Licensed Radio Services
ANSI C63.2: 1996	American National Standard for Instrumentation-Electromagnetic Noise and Field Strength, 10 kHz to 40 GHz-Specifications.
ANSI C63.4: 2014	American National Standard for Methods of Measurement of Radio-Noise Emissions from Low-Voltage Electrical and Electronic Equipment in the Range of 9 kHz to 40 GHz.
KDB 971168 D01 v03r01	Measurement Guidance for Certification of Licensed Digital Transmitters
KDB 940660 D01 v01	Certification and Test Procedures for Citizens Broadband Radio Service Devices Authorized under Part 96
KDB 662911 D01 v02r01	Emissions Testing of Transmitters with Multiple Outputs in the Same Band
KDB 662911 D02 v01	MIMO with Cross-Polarized Antenna



12 APPENDIX E Test equipment correction factors

Antenna factor  
Active loop antenna  
Model 6502, S/N 2857, HL 0446

Frequency, MHz	Measured antenna factor, dBS/m
0.009	-32.5
0.010	-33.4
0.020	-37.9
0.050	-40.6
0.075	-41.0
0.100	-41.2
0.150	-41.2
0.250	-41.2
0.500	-41.3
0.750	-41.3
1.000	-41.4
2.000	-41.4
3.000	-41.4
4.000	-41.5
5.000	-41.5
10.000	-41.8
15.000	-42.2
20.000	-42.9
25.000	-43.9
30.000	-45.4

Antenna factor is to be added to receiver meter reading in dB( $\mu$ V) to convert it into field strength in dB( $\mu$ V/m).



**Antenna factor**  
**Trilog antenna**  
**Model ALX-8000E, Frankonia, S/N 00809, HL 5288, 30-1000 MHz**

Frequency, MHz	Antenna factor, dB/m		
	Vert Up	Vert Down	Delta
30	-51.19	-51.28	0.09
35	-44.03	-44.12	0.09
40	-43.07	-43.12	0.05
45	-39.61	-39.79	0.18
50	-37.84	-38.14	0.3
60	-34.93	-34.9	0.03
70	-29.76	-29.66	0.1
80	-27.69	-27.82	0.13
90	-29.05	-29.07	0.02
100	-31.19	-31.19	0
120	-31.61	-31.6	0.01
140	-28.13	-28.06	0.07
160	-27.71	-27.75	0.04
180	-26.19	-26.15	0.04
200	-28.2	-28.15	0.05
250	-27.45	-27.47	0.02
300	-29.61	-29.63	0.02
400	-31.77	-31.78	0.01
500	-32.81	-32.81	0
600	-33.64	-33.61	0.03
700	-34.21	-34.21	0
800	-35.66	-35.66	0
900	-36.99	-36.91	0.08
1000	-38	-37.91	0.09

Antenna factor in dB(1/m) is to be added to receiver meter reading in dB( $\mu$ V) to convert it into field intensity in dB( $\mu$ V/m).





**Antenna factor**  
**Active Horn Antenna,**  
**Com-Power Corporation, model: AHA-118, s/n 701046, HL 4933**

Frequency, MHz	Measured antenna factor (with preamplifier), dB/m
1000	-16.1
1500	-15.1
2000	-10.9
2500	-11.9
3000	-11.1
3500	-10.6
4000	-8.6
4500	-8.3
5000	-5.9
5500	-5.7
6000	-3.3
6500	-4.0
7000	-2.2
7500	-1.7
8000	1.1
8500	-0.8
9000	-1.5
9500	-0.2

Frequency, MHz	Measured antenna factor (with preamplifier), dB/m
10000	1.8
10500	1.0
11000	0.3
11500	-0.5
12000	3.1
12500	1.4
13000	-0.3
13500	-0.4
14000	2.5
14500	2.2
15000	1.9
15500	0.5
16000	2.1
16500	1.2
17000	0.6
17500	3.1
18000	4.2

The antenna factor shall be added to receiver reading in dB $\mu$ V to obtain field strength in dB $\mu$ V/m.



**Antenna factor**  
**Active Horn Antenna,**  
**Com-Power Corporation, model: AHA-840, s/n 105004, HL 4956**

Frequency, MHz	Measured antenna factor (with preamplifier), dB/m
18000	2.5
18500	0.5
19000	-1.0
19500	-2.4
20000	-2.5
20500	-2.2
21000	-2.0
21500	-2.7
22000	-3.7
22500	-3.8
23000	-3.7
23500	-5.0
24000	-4.5
24500	-5.0
25000	-4.7
25500	-4.4
26000	-4.3
26500	-5.6
27000	-4.3
27500	-4.9
28000	-5.2
28500	-4.4

Frequency, MHz	Measured antenna factor (with preamplifier), dB/m
29000	-2.7
29500	-2.6
30000	-1.4
30500	-1.5
31000	-1.0
31500	-2.6
32000	-3.3
32500	-3.3
33000	-5.1
33500	-5.2
34000	-1.5
34500	-5.4
35000	-3.3
35500	-4.2
36000	-2.8
36500	-2.6
37000	-1.0
38000	1.8
38500	2.8
39000	1.3
39500	1.3
40000	0.3

The antenna factor shall be added to receiver reading in dB $\mu$ V to obtain field strength in dB $\mu$ V/m.



**Cable loss**  
**Test Cable, Mini-Circuits, CBL-5FT-SMSM+, SMA-SMA, 18 GHz, 1.5 m, S/N 25679**  
**Mini-Circuits, HL 3433**

Frequency, MHz	Cable loss, dB	Frequency, MHz	Cable loss, dB
10.0	0.06	9000	2.01
100	0.17	9500	2.06
500	0.41	10000	2.05
1000	0.58	10500	2.18
1500	0.72	11000	2.26
2000	0.86	11500	2.28
2500	0.96	12000	2.43
3000	1.04	12500	2.53
3500	1.13	13000	2.52
4000	1.23	13500	2.56
4500	1.31	14000	2.60
5000	1.41	14500	2.59
5500	1.49	15000	2.67
6000	1.55	15500	2.76
6500	1.63	16000	2.86
7000	1.71	16500	2.91
7500	1.78	17000	2.95
8000	1.86	17500	3.02
8500	1.92	18000	3.07



**Cable loss**  
**Test Cable, Mini-Circuits, CBL-5FT-SMSM+, SMA-SMA, 18 GHz, 1.5 m, S/N 25683**  
**Mini-Circuits, HL 3434**

Frequency, MHz	Cable loss, dB	Frequency, MHz	Cable loss, dB
10.0	0.06	9000	1.96
100	0.16	9500	2.01
500	0.40	10000	2.01
1000	0.57	10500	2.14
1500	0.72	11000	2.21
2000	0.85	11500	2.24
2500	0.95	12000	2.36
3000	1.03	12500	2.47
3500	1.11	13000	2.46
4000	1.21	13500	2.50
4500	1.29	14000	2.53
5000	1.39	14500	2.53
5500	1.46	15000	2.62
6000	1.52	15500	2.70
6500	1.60	16000	2.80
7000	1.68	16500	2.86
7500	1.75	17000	2.88
8000	1.83	17500	2.94
8500	1.88	18000	3.00



**Cable loss**  
**Microwave Cable Assembly, Huber-Suhner, 40 GHz, 1.5 m, SMA-SMA, S/N 1226/2A**  
**HL 3903**

Frequency, MHz	Cable loss, dB	Frequency, MHz	Cable loss, dB	Frequency, MHz	Cable loss, dB
10	-0.02	9500	1.84	21000	2.98
100	0.15	10000	1.86	22000	3.07
500	0.38	10500	1.93	23000	3.13
1000	0.56	11000	1.99	24000	3.21
1500	0.69	11500	2.04	25000	3.26
2000	0.82	12000	2.10	26000	3.48
2500	0.90	12500	2.15	27000	3.44
3000	0.98	13000	2.21	28000	3.53
3500	1.06	13500	2.25	29000	3.59
4000	1.11	14000	2.29	30000	3.66
4500	1.17	14500	2.34	31000	3.70
5000	1.24	15000	2.36	32000	3.79
5500	1.32	15500	2.40	33000	3.88
6000	1.40	16000	2.45	34000	3.94
6500	1.50	16500	2.48	35000	3.91
7000	1.56	17000	2.56	36000	4.05
7500	1.62	17500	2.58	37000	4.22
8000	1.68	18000	2.60	38000	4.25
8500	1.74	19000	2.84	39000	4.27
9000	1.78	20000	2.88	40000	4.33



HERMON LABORATORIES

**Cable loss**  
RF Cable, Huber-Suhner, 18 GHz, 6 m,  
SF118/11N(x2), S/N 500023/118  
HL 5405

5405



# Specific Test Report

Frequency Range [GHz]	IL min S21 [dB]	IL min S12 [dB]	RL max S11 [dB]	RL max S22 [dB]
0.040 - 1.836	-1.431	-1.431	-37.037	-37.704
1.836 - 3.632	-2.062	-2.066	-33.573	-32.848
3.632 - 5.428	-2.576	-2.576	-28.548	-29.602
5.428 - 7.224	-3.013	-3.014	-30.738	-32.523
7.224 - 9.020	-3.415	-3.416	-33.728	-32.257
9.020 - 10.816	-3.772	-3.772	-29.302	-30.735
10.816 - 12.612	-4.138	-4.138	-28.768	-26.255
12.612 - 14.408	-4.456	-4.462	-27.109	-26.151
14.408 - 16.204	-4.786	-4.786	-26.056	-27.116
16.204 - 18.000	-5.113	-5.111	-27.762	-28.508

Type: SF118/11N/11N/6000MM  
Sales no.: 10497130  
Serial no.: 500023 /118  
PA no.: 1956306  
Ring no.:  
Cable length: 6 m  
Test length:  
Connector 1: SF\_11\_N-656  
Connector 2: SF\_11\_N-656  
Cable: SUCOFLEX\_118  
Meas. System: N5230C,MY49001834,A.09.42.22  
Time: 7:04:21 AM  
Date: 6/6/2018  
Inspected by: AZ /111  
Start Freq.: 0.04000 GHz  
Stop Freq.: 18.00000 GHz  
Meas Points: 801  
Source Power: -5 dBm



### 13 APPENDIX F Abbreviations and acronyms

A	ampere
AC	alternating current
A/m	ampere per meter
AM	amplitude modulation
AVRG	average (detector)
BB	broad band
cm	centimeter
dB	decibel
dBm	decibel referred to one milliwatt
dB( $\mu$ V)	decibel referred to one microvolt
dB( $\mu$ V/m)	decibel referred to one microvolt per meter
dB( $\mu$ A)	decibel referred to one microampere
dB $\Omega$	decibel referred to one Ohm
DC	direct current
EIRP	equivalent isotropically radiated power
ERP	effective radiated power
EUT	equipment under test
F	frequency
GHz	gigahertz
GND	ground
H	height
HL	Hermon laboratories
Hz	hertz
ITE	information technology equipment
k	kilo
kHz	kilohertz
LISN	line impedance stabilization network
LO	local oscillator
m	meter
MHz	megahertz
min	minute
mm	millimeter
ms	millisecond
$\mu$ s	microsecond
NA	not applicable
NB	narrow band
NT	not tested
OATS	open area test site
$\Omega$	Ohm
QP	quasi-peak
PM	pulse modulation
PS	power supply
RE	radiated emission
RF	radio frequency
rms	root mean square
Rx	receive
s	second
T	temperature
Tx	transmit
V	volt
VA	volt-ampere

END OF DOCUMENT