

**IBM®**

**Bluetooth UltraPort  
Module from IBM**

---

*User's Reference Guide*

**OPTIONS**

*by IBM*

**First Edition (February 2001)**

**The following paragraph does not apply to the United Kingdom of any country where such provisions are inconsistent with local law:**

INTERNATIONAL BUSINESS MACHINES CORPORATION PROVIDES THIS PUBLICATION "AS IS" WITHOUT ANY WARRANTY OF ANY KIND, EITHER EXPRESS OR IMPLIED, INCLUDING, BUT NOT LIMITED TO, THE LIMITED WARRANTIES OF MERCHANTABILITY OF FITNESS FOR A PARTICULAR PURPOSE. Some states do not allow disclaimers or express or implied warranties in certain transactions; therefore, this statement may not apply to you.

This publication could include technical or typographical errors. Changes are periodically made to the information herein; these changes will be incorporated in new editions of the publication. IBM may make improvements or changes in the products or the programs described in this publication at any time.

It is possible that this publication may contain reference to, or information about, IBM products (machines and programs), programming, or services that are not announced in your country. Such references or information must not be construed to mean that IBM intends to announce such IBM products, programming, or services in your country.

Requests for technical information about IBM products should be made to your IBM authorized dealer or your IBM marketing representative.

**© Copyright International Business Machines Corporation 2001. All rights reserved.**

Note to U.S. Government users - Documentation related to restricted rights - Use, duplication or disclosure is subject to restrictions set forth in GSA ADP Schedule Contract with IBM Corp.



---

# Contents

---

## **About the Bluetooth UltraPort Module from IBM**

- Registering your product
- About the Product
- Parts and Parts Numbers
- Hardware, Software, and OS requirements
- Computers that need an external USB connector
- Installation Procedure
- Safety Warnings
- Safety Statements

## **Physical Installation of the Module**

- Step 1 - Physical Installation of the interposer and the module
- Physical Installation on laptops with a bay
- Physical Installation on laptops without a bay and on desktop computers
- Physical Installation on X20 Series
- Installation of the module's clip-on cover

## **Installation of the Drivers**

- Installation of the software on a laptop
- Installation of the software on a desktop
- Updating the system BIOS

## **Installation of the Applications**

- Installation the applications on laptops
- Installation the applications on desktops

## **Using IBM Ultraport Bluetooth**

Hints and Tips

Working with the Bluetooth Ultraport Module's Applications

The Bluetooth Ultraport Module's Control Panel

## **Getting Help**

How to open the software online user's guide

## **In Addition**

Appendix A. Help and Service Information

Appendix B. Product Warranties

## **Registering Your Product**

Thank you for purchasing the Bluetooth UltraPort Module from IBM. Please take a few moments to register your product and provide us with information that will help IBM to better serve you in the future. Your feedback is valuable to us in developing products and services that are important to you, as well as in developing better ways to communicate with you. Register your product on the IBM site at:

<http://www.ibm.com/pc/register>

IBM will send you information and updates on your registered product unless you indicate on the Web site questionnaire that you do not want to receive further information.

## About the Product

The Bluetooth UltraPort Module from IBM (sometimes referred as USB device) is a device allowing your ThinkPad to communicate with other devices without the use of a cable. It is fast becoming a must-have communication tool.

The Bluetooth UltraPort Module from IBM is “Plug & Play” compatible, which makes installation simple.

If you are using a supported IBM ThinkPad, the IBM UltraPort Bluetooth is configured automatically when you connect it to your computer. In addition you will need to use a USB cable to connect your ThinkPad to the Bluetooth UltraPort Module from IBM. These extra parts are provided with the product.

Using the Bluetooth UltraPort Module from IBM and the accompanying software, you can spice up your communication needs and be synchronized all the time when on the move.

1/ The list of laptops supported is as follows:

ThinkPad T20/T21/T22

ThinkPad A20/A21

ThinkPad X20/X21

Thinkpad TransNote

ThinkPad i Series

ThinkPad 600/E/X

ThinkPad 570/E

ThinkPad 390E/X

ThinkPad 240/X/Z

**Note:** Some of these laptop have an UltraPort connector, other don't have an UltraPort connector and need to be attached through the external USB connector.

2/ The list of desktops supported is as follows:

NetVista A60

NetVista A60i

NetVista A40

NetVista A40i

NetVista X40i

NetVista A40/p

NetVista S40/p

NetVista X40

NetVista A20

NetVista A20i

All of the desktop systems will be connected via the external USB connector.



## Parts and Parts Numbers

When you open the box containing the Bluetooth UltraPort Module from IBM, you can see the following content:

- The IBM Ultraport Bluetooth module (USB module)
- The IBM system BIOS update CD
- The Bluetooth Ultraport CD
- A parts kit including:
  - A USB cable
  - Interposers (2)
  - Spacers (2, for X20 Series ThinkPad systems)
  - The clip-on cover for IBM Ultraport Bluetooth
  - A tripod
  - A tripod housing unit

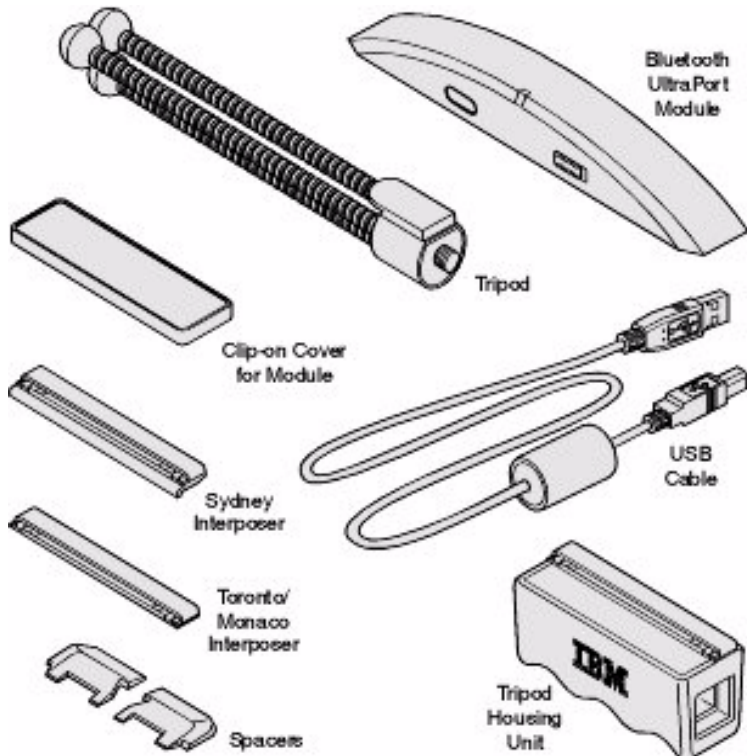

Please note that for each part you have a FRU part number and an IBM part number. Find these part numbers below:

<b>Part Name</b>	<b>FRU Number</b>	<b>IBM Part Number</b>
Adapter ASM	08K6108	
Bluetooth UltraPort Module	09N9813	

Bluetooth UltraPort Sydney Spacers	22P4907	
Interposers and Cover	04P3072	
Tripod	08K6449	
USB Cable	27L0542	

Here are some of them: The numbers on the left are IBM FRU part numbers with descriptions etc.

04P3072 Interposers and cover FRU

27L0542 USB CABLE FRU

08K6108 Adapter ASM FRU

08K6449 Tripod FRU

09N9813 Bluetooth UltraPort FRU Module

22P4907 Bluetooth UltraPort Sydney Spacers FRU

Bob.

let me know if this is unclear.

**Note:** You need the USB only if you use a desktop computer or one of the following laptops:

ThinkPad i Series

ThinkPad 600/E/X

ThinkPad 570/E

ThinkPad 390E/X

ThinkPad 240/X/Z

NetVista A60

NetVista A60i

NetVista A40

NetVista A40i  
NetVista X40i  
NetVista A40/p  
NetVista S40/p  
NetVista X40  
NetVista A20  
NetVista A20i

## Hardware, Software, and OS Requirements

The Bluetooth UltraPort Module from IBM can be attached to the UltraPort bay located at the top of the display on the following ThinkPad systems: T20, A20p, and X20 Series ThinkPad.

The UltraPort Bluetooth device can also be attached to your ThinkPad system using the external USB cable and adapter.

**If you use one of the above systems, you can either use the Bluetooth UltraPort Module from IBM or the external USB connection.**

**Note:** The UltraPort Bluetooth device can also be attached to the following ThinkPad systems using the external USB connection:

**If you do not use one the above systems, you will still be able to use the Bluetooth UltraPort Module from IBM via the external USB connection. The other systems that you can use are the following:**

Your ThinkPad must fulfill the following requirements:

- Required disk space to load the software: At least 25 MB
- A CD-ROM drive or a DVD drive
- Windows 98 SE, Windows 2000, or Windows Me

### *About Windows Versions*

To check which version of Windows you are using, do the following:

- Click **Start, Settings, and Control Panel**
- Click **System**
- Read the numbers under **System**

They indicate which version of Windows you are using.

## **Computers that need an external USB connector**

There are two types of laptops and depending on the laptop you are using the Bluetooth UltraPort Module installation procedure is different. The list of laptops supported is as follows:

ThinkPad T20/T21/T22  
ThinkPad A20/A21  
ThinkPad X20(unique portofino connector)/X21  
Thinkpad TransNote

The above systems do not require an external USB connector.

There are other systems that do not have a portofino connector and that require an external USB connector. They are:

ThinkPad i Series  
ThinkPad 600/E/X  
ThinkPad 570/E  
ThinkPad 390E/X  
ThinkPad 240/X/Z  
NetVista A60  
NetVista A60i  
NetVista A40  
NetVista A40i  
NetVista X40i  
NetVista A40/p  
NetVista S40/p  
NetVista X40  
NetVista A20  
NetVista A20i

# Installation Procedure

Whether you use a laptop (supported or not supported) or a desktop computer, the installation procedure is the same:

Install physically the module on the bay of your computer

You have to either install the module on top of your ThinkPad or connect it to the USB cable

Turn on the computer and insert the CD in the CD drive

Install the software

This include installing the Intel stack, the TDK applications, and the device drivers

You can now start using the Bluetooth UltraPort Module from IBM.

Very important: If you are installing your Bluetooth UltraPort Module on the bay of your computer, you need to stick to this installation procedure as you will not be able to operate your Bluetooth UltraPort module if you choose another installation sequence.

Note if you plan to install the Bluetooth UltraPort Module on the bay of your computer: Your Bluetooth UltraPort Module is not hot-pluggable therefore it needs to be installed on the bay before the computer is turned on. Your Bluetooth UltraPort Module from IBM will not work if you turn on your computer, then install physically the module. If you remove it, if you decide to use it again, you need to turn off your computer, reinstall it physically on the bay, then turn on your computer again.

Note if you plan to install the Bluetooth UltraPort using the USB cable: In case you install your Bluetooth UltraPort Module using a the USB cable, you will be able to install physically the module, then turn on the computer and install the drivers and the applications. You will also be able to turn on your computer, then connect the module to the tripod and the computer using the cable, then install the drivers and the applications.

Note regarding Bluetooth and the wake-up mode: Your Bluetooth UltraPort Module from IBM does not support the wake-up mode, therefore it will not be able to come out from Standby or Hibernation mode. If you were using your Bluetooth UltraPort Module from IBM, and then decided to put your computer in standby or hibernation



mode, you need to physically turn on the module using the shutter button to use Bluetooth again.

## Safety Warnings

Please make sure you read the following points before you start using your Bluetooth UltraPort Module:

Only avoid using it in airplanes and hospitals. If you need to travel with the Bluetooth UltraPort module from IBM and have to go to a hospital or to any place where electronic equipment is used, switch off the unit completely, or remove it.

Make sure the your Bluetooth UltraPort Module is kept at a distance of at least 22 cm of a pacemaker. The Bluetooth UltraPort Module may impact the functioning of the pacemaker. As you may not know who has and who hasn't a pacemaker, make sure you have removed the module from your computer whenever you are in a crowd.

As a rule make sure you don't use your module when you are close to any electronic equipment. This includes fire detectors, automatic doors, etc. Keep your Bluetooth UltraPort Module at a distance of at least 2m from any OA, AV piece of equipment, and at least 3m away from a microwave oven. If you work too close to a TV set or a radio receiver, you may not be able to communicate with other devices and at the same time your Bluetooth equipment may impact the quality of your TV image or the quality of the reception of your radio receiver.

Do not detach the UltraPort device while an application is running.

Although your ThinkPad computer has two USB ports, use only one port at a time for a camera. You cannot use cameras in both ports at the same time. If your ThinkPad has a UltraPort connector, you can choose either the connector or a USB port.

Do not put an operating cellular phone near the computer when using the Ultraport Bluetooth device. It might cause a system malfunction.

# Safety Statements

Please note the two following Underwriters Laboratories Inc.'s notices:

" This product is for use only with UL Listed personal computers."

"The long-term characteristics or the possible physiological effects of radio frequency (RF)electromagnetic fields associated with this equipment have not been evaluated."

## **In addition:**

This device complies with Part 15 of the FCC rules and with RSS-210 of Industry Canada. Operation is subject to the following two conditions:

- (1) This device may not cause harmful interference
- (2) This device must accept any interference received, including interference that may cause undesired operation.

## **Important**

### **Please note the following:**

This equipment has been tested and found to comply with the limits for a Class B digital device, pursuant to part 15 of the FCC Rules. These limits are designed to provide reasonable protection against harmful interference in a residential installation. This equipment generates, uses and can radiate radio frequency energy and, if not installed and used in accordance with the instructions, may cause harmful interference to radio communications. However, there is no guarantee that interference will not occur in a particular installation. If this equipment does cause harmful interference to radio or television reception, which can be determined by turning the equipment off and on, the user is encouraged to try to correct the interference by one or more of the following measures:--Reorient or relocate the receiving antenna.--Increase the separation between the equipment and receiver.--Connect the equipment into an outlet on a circuit dif-

ferent from that to which the receiver is connected.--Consult the dealer or an experienced radio/TV technician for help.

Changes or modifications not expressly approved IBM Corporation could void the user's authority to operate the equipment.

# Installing the Bluetooth UltraPort Module from IBM on a ThinkPad

Your product is a combination of hardware and software.

Before you start using IBM Ultraport Bluetooth, check the following:

- Your computer runs on one of the following platform: Windows 98 SE, Windows 2000
- Your IBM Ultraport Bluetooth kit contains the following items:
  - The Bluetooth UltraPort Module from IBM (USB device)
  - The IBM system BIOS update CD
  - The IBM Ultraport Bluetooth CD
  - A parts kit including:
    - A USB cable
    - Interposers
    - Spacers (for X20 Series ThinkPad systems)
    - The clip-on cover for IBM Ultraport Bluetooth
    - A tripod
    - A tripod housing unit
- You are using one of the following IBM ThinkPads: X20, T20, or A20p, as well as some other non IBM systems.

Note: If you are not using an IBM ThinkPad, you will still be able to use IBM Ultraport Bluetooth via the USB cable provided in the kit. Other non IBM systems you can use with the Bluetooth UltraPort Module from IBM are the following:

Important: Before you install IBM Ultraport Bluetooth take a moment to review the hardware and software listed above and make sure that everything works properly. As you examine the IBM UltraPort Bluetooth kits items, look for any physical damage. Confirm that IBM UltraPort Bluetooth inserts correctly. Retain the shipping container to use in the unlikely event that you need to return the IBM™ UltraPort Bluetooth device for service.



# Step 1 - Physical Installation of the interposer and the module

The first step of the installation if you are a ThinkPad user is to install the interposers.

If you are a desktop user, you don't need interposers. Please refer to the chapter **Installing the module on a desktop computer**.

When you open the box, you will see that two interposers are included. If you are using anything else than a x20 series ThinkPad, you need to use the Monaco/Toronto interposer.

If you are a x20 series ThinkPad user, you need to use the Sydney interposer.

To install the interposer, do the following:

- With a pin, lift the plastic that is covering the USB port
- Remove the plastic cover completely

Now you can see the port without the cover. Next step you need to screw the interposer on the port.

The interposer is shown below:

You can see that it folds in two. The interposer is made of a plastic flap and a metal part.

**Important:** there is only one correct way to screw the interposer on the computer: the flap should face the keyboard. Look at the picture below:

You can see that there are two screwing points.

- Using a Phillips headset screwdriver, screw the interposer on the port

Next step is to install the Bluetooth UltraPort Module on the interposer.

- Take the Bluetooth UltraPort Module making sure that the release latch is on the left

As you can see on the lower part of the module the Bluetooth UltraPort Module has 5 pins on the right and 8 on the left. These pins on the module should match the connectors on the port:

There are also two notches on the module and two holes on the port that should match.

- Clip in the module on the port

You have completed the physical installation of the Bluetooth UltraPort Module.



## Physical Installation on X20 Series

If you are a X20 Series user you need to install the two spacers on your UltraPort device before installing it on your laptop. The two spacers are included in the kit. They are shaped after the module and fit perfectly.

Procedure:

- Peel the tape off the left spacer and attach it to the bottom left of the module
- Match the spacer to the slot of the module firmly
- Attach the right spacer to the bottom right of the module
- Match the spacer to the slots of the module firmly

For how to connect the module to your computer, refer to Physical Installation on laptops.

# Installing the module on a desktop computer

Do the following:

- Make sure the computer is off
- Take the USB cable and connect it to the USB port
- Connect the USB cable to the tripod

You can see a release latch on the right of the module.

- Slide it to the left and clip the module on the tripod

There is a shutter button on the left.

- Turn it on
- Turn on your computer
- Insert the CD in the CD (DVD) drive
- Select Run in the Start menu
- Browse until you find the IBM UltraPort Bluetooth software
- Select Bluetooth UltraPort Module
- Select a suitable language for the setup process
- Click OK
- Click Next
- Click Finish

The Install wizard starts.

The computer is installing the software.

Making sure the software is correctly installed

To make sure the Bluetooth UltraPort Module has been properly installed, proceed as follows:

- Click the My Computer folder
- Click C
- Click Program Files

You should see a newly created folder named TDK Systems Europe.

If you cannot see this folder, repeat the installation procedure.

**Note:** Another way to check that this software has been correctly installed is to check in the taskbar that the control panel icon is visible.



## Installation of the module's clip-on cover

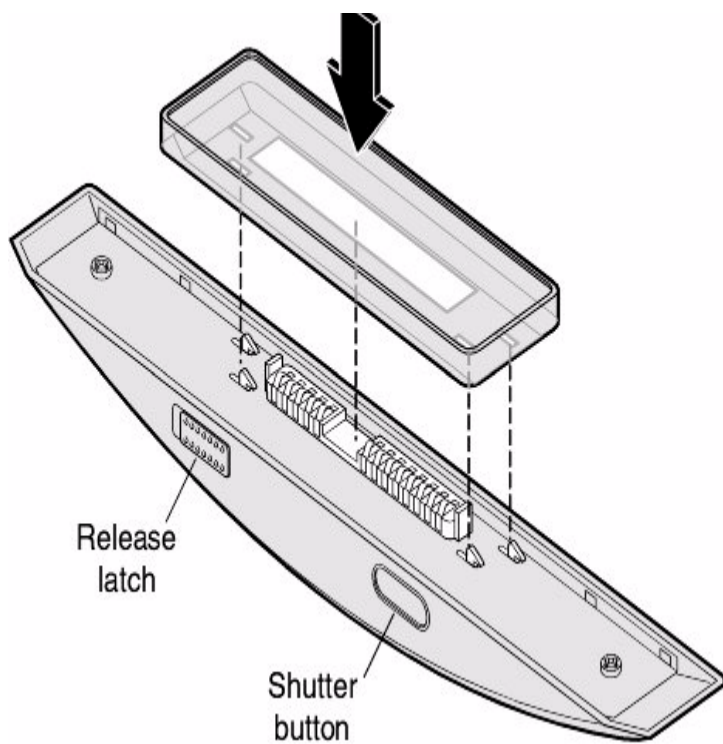

## Installation of the drivers on laptops

Before running the IBM UltraPort Bluetooth application, you must install it from the CD onto your hard disk. You cannot run the install program from the CD. Installation instructions are available below.

**Note:** Please refer to the previous section (Required Hardware) to make sure that you have the required hardware and that your IBM UltraPort Bluetooth kit is in good working order.

Once you have inserted the software's CD in your computer the installation procedure should start automatically. If this is not the case, please read the following paragraph.

**Note:** Before installing the software, you need to sit the Bluetooth UltraPort Module from IBM on your computer. The device is delivered with a small plastic cover that you need to remove and replace by the interposer. Please refer to the UltraPort section

### Installation of IBM Ultraport Bluetooth on a ThinkPad

The IBM UltraPort Bluetooth software works only with the Windows 98 Second Version platform. It may work at a later stage with Windows 2000 as well.

To install the Portofino device, proceed as follows:

- Make sure your computer is switched off
- Make sure the interposer is there
- If not, put it there
- Open your ThinkPad
- Place the Bluetooth UltraPort Module from IBM on the top of the cover, inserting it in the dedicated port
- Turn on your ThinkPad
- Insert the CD in the CD (DVD) drive
- Select Run in the Start menu

- Browse until you find the IBM UltraPort Bluetooth software
- Select IBM UltraPort Bluetooth
- Select a suitable language for the setup process
- Click OK
- Click Next
- Click Finish

The Install wizard starts.

The computer is installing the software.

### **Making sure the software is correctly installed**

To make sure IBM UltraPort Bluetooth has been properly installed, proceed as follows:

- Click the My Computer folder
- Click C
- Click Program Files

You should see a newly created folder named TDK Systems Europe.

If you cannot see this folder, repeat the installation procedure.

**Note:** Another way to check that this software has been correctly installed is to check in the task bar that the program's icon is visible.

### **Installation Procedure for the spacer (X20 Series)**

## **Installation of the drivers on desktops**

# Updating the System BIOS

You must update the BIOS (basic input/output system) of your ThinkPad computer to use the Bluetooth UltraPort module.

Below is a list of BIOS versions that need to be updated prior to use the Bluetooth UltraPort module. The latest Flash BIOS Update program file can be obtained from each folder:

Note that the BIOS versions listed in the following list may not be the latest as IBM keeps updating the BIOS. Please make sure to download and update to the latest BIOS available on the web:

<http://www.pc.ibm.com/support>

ThinkPad Model	Folder Name in CD-ROM
T20	BIOS\TPT20\US
T21	BIOS\TPT21\US
T22	BIOS\TPT22\US
A20p	BIOS\TPA20p\US
A21p/A22	BIOS\TPA21p\US
X20 / X21/ i Series1620	BIOS\TPX20\US

## Installation Instructions

### Note:

Make sure you of the following:

- You need an AC adapter and a charged battery pack to update the system program.
- If your computer is attached to any kind of port replicator, turn off the computer and detach it before proceeding.
- Before using Flash Update with Windows 98 Second Edition, IBM recommends that you download and apply the "Windows



98 Second Edition Shutdown Supplement" from the Microsoft Support WWW Site.

Information regarding this supplement can be found at:

<http://support.microsoft.com/support/kb/articles/Q239/8/87.ASP>

Follow this procedure:

Open the above link

- Click on <http://www.microsoft.com/windows/98/downloads/corporate.asp>
- Scroll down to "Windows 98 Second Edition Shutdown Supplement"
- Click on it
- Click Next
- Accept the License to download the file
- Run the executable that you just downloaded

***Instructions:***

1. Print these instructions or display on another computer
2. Firmly connect the AC adapter to the computer
3. Start Windows 95/98/Me/2000 or Windows NT 4.0 on the target computer
4. Make the temporary directory on the hard drive (for instance, C:\Temp)
5. Copy the ThinkPad BIOS Update Utility from the Setup CD
6. Store the file into the temporary directory. (e.g. C:\Temp)
7. Click on the Start button
8. Click on Run
9. Specify filename with the full path name where you stored ThinkPad Update Utility
10. Press Enter

When the procedure is completed, the system is automatically turned off.

**Warning!!**

Do not turn off or suspend the computer until the update has been completed.

**IF YOU TURN OFF OR SUSPEND THE COMPUTER WHILE THE UPDATE IS STILL IN PROGRESS, THE SYSTEM BOARD MAY HAVE TO BE REPLACED.**

After the update has been completed, do the following to confirm the change is correctly applied:

1. Make sure that no diskette is inserted in the diskette drive
2. Turn on the computer

The "Press F1 for IBM BIOS Setup Utility" message is displayed at the lower-left area of the screen.

3. Press the F1 key
- A password prompt may appear.
4. Type the correct password
  5. Check "BIOS Version"

## **Installation of the Applications on laptops**

## **Installation of the Applications on desktops**

# How to Open the Software Online User's Guide

To be able to read online instruction, you need to install Adobe Acrobat Reader.

To read online instruction, proceed as follows:

1. Insert the Portofino Software CD-ROM

Now, you need to install Adobe Acrobat. To do so, proceed as follows:

2. Click Start
3. Click Run
4. Type x: \ACROBAT\cc

x is the drive letter of the CD-ROM or DVD drive. cc is the language code. It is one of the following:

Brazilian Portuguese: BP

Chinese, Simplified: CH

English: US

French: FR

German: DE

Italian: IT

Japanese: JP

Spanish: SP

5. Double click xxxx.EXE

xxxx.EXE is the file name in the directory. It is one of the following:

AR40POR for BP (Brazilian Portuguese)

AR40chs for CH (Chinese Simplified)

AR40DEU for DE (German)

AR40FRA for FR (French)

AR40ITA for IT (Italian)

AR40JPN for JP (Japanese)

AR40ESL for ES (Spanish)

AR405ENG for US (English)

### **About Online Help**

You can open the UltraPort Bluetooth Module online help by clicking the Help in the menu bar, or by pressing F1. Help provides you with links to the online version of this *User's Reference Guide*. The design of the Help function is similar to the Windows Help.

# **Working with the Bluetooth Bluetooth UltraPort Module's Applications**

Applications currently encompasses the following software:

- OBEX for Bluetooth
- OBEX Server
- File Transfer Application
- vCard Exchange Application
- Outlook Integration
- Bluetooth Modem
- Chat
- Synchronization

# IBM Ultraport Bluetooth's Control Panel

The Bluetooth Ultraport Control Panel allows you to customize settings.

In order to open the IBM Ultraport Bluetooth Control Panel, double-click on the pink IBM Ultraport Bluetooth icon located in the lower right corner.

You will be displayed the window shown below:

The Properties and Policies window is made of three tabs:

- General
- Security
- Power

## General Tab

You can see in the lower part of the screen the Basic Settings. Once the device is on, the **ON** radio button is selected. In order to turn off IBM Ultraport Bluetooth, you can either select the **OFF** radio button, or turn off the device hardware that sits on your computer.

In order to access the **Security** Tab, just click it.

## Security Tab

The Security Tab allows you to set up the security level. There are 6 levels, the sixth level being the one with maximum security.



# Hints and Tips

# Appendix A.

## Help and Service Information

### Online Technical Support

Online Technical Support is available during the life of your product. Online Assistance can be obtained through the Personal Computing Support Web site and the IBM Automated Fax system.

**TABLE 1. Online Technical Support**

IBM Personal Computing Support Web Site	<a href="http://www.ibm.com/pc/support/">http://www.ibm.com/pc/support/</a>
IBM Automated Fax System	1-800-426-3395 (U.S. and Canada)

During the warranty period, assistance for replacement or exchange of defective components is available. In addition, if your IBM option is installed in an IBM computer, you might be entitled to service at your location. Your technical support representative can help you determine the best alternative.

### Telephone Technical Support

Marketing, installation, and configuration support through the Help-Center will be withdrawn or made available for a fee, at IBM's discretion.

## **Appendix B. Product Warranties**

The warranty statement consists of two parts: Part 1 and Part 2. Part 1 varies by country. Part 2 is the same for both statements. Be sure to read both the Part 1 that applies to your country and Part 2.

- **United States, Puerto Rico, and Canada (Z125-4753-05 11/97)**  
(Part 1 - General Terms on page 2-3)
- **Worldwide except Canada, Puerto Rico, Turkey, and United States**  
(Z125-5697-01 11/97)
- (Part 1 General terms on page 2-5)
- **Worldwide Country-Unique Terms**  
(Part 2 -Country-Unique Terms on page 2-8)

### **IBM Statement of Limited Warranty for United States, Puerto Rico, and Canada (Part 1 - General Terms)**

This statement of Limited Warranty includes Part 1 -General Terms and Part 2 - Country-unique Terms. The terms of Part 2 may replace or modify those of Part 1. The warranties provided by IBM in this statement of Limited Warranty apply only to Machines purchase for your use, and not for resale, from IBM or your reseller. The term “Machine” does not include any software programs, whether pre-loaded with the Machine, installed subsequently or otherwise. Unless IBM specifies otherwise, the following warranties apply only in the countries where you acquire the Machine. Nothing in this Statement of Warranty affects any statutory right of consumers that cannot be waived or limited by contract. If you have any questions, contact IBM or your reseller.

**Machine** - IBM Portofino

**Warranty Period\*** - One year

*\*Contact your place of purchase for warranty service information. Some IBM Machines are eligible for On-site warranty service depending on the country where service is performed.*

### **The IBM Warranty for Machines**

IBM warrants that each Machine 1) is free from defects in materials and workmanship and 2) conforms to IBM's Official Published Specifications. The warranty period for a Machine is a specified, fixed period commencing on its Date of Installation. The date on your sales receipt is the Date of Installation, unless IBM or your reseller informs you otherwise.

During the warranty period IBM or your reseller, if approved by IBM to provide warranty service, will provide repair and exchange service for the Machine, without charge, under the type of service designated for the Machine and will manage and install engineering changes that apply to the Machine.

If a Machine does not function as warranted during the warranty period, and IBM or your reseller are unable to either 1) make it do so or 2) replace it with one that is at least functionally equivalent, you may return it to your place of purchase and your money will be refunded. The replacement may not be new, but will be in good working order.

### **Extent of Warranty**

The warranty does not cover the repair or exchange of a Machine resulting from misuse, accident, unsuitable physical or operating environment, improper maintenance by you, or failure caused by a

product for which IBM is not responsible. The warranty is voided by removal or alteration of Machine or parts identification labels.

**THESE WARRANTIES ARE YOUR EXCLUSIVE WARRANTIES AND REPLACE ALL OTHER WARRANTIES OR CONDITIONS, EXPRESS OR IMPLIED, INCLUDING, BUT NOT LIMITED TO, THE IMPLIED WARRANTIES OR CONDITIONS OF MERCHANTABILITY AND FITNESS FOR A PARTICULAR PURPOSE. THESE WARRANTIES GIVE YOU SPECIFIC LEGAL RIGHTS AND YOU MAY ALSO HAVE OTHER RIGHTS WHICH VARY FROM JURISDICTION TO JURISDICTION. SOME JURISDICTIONS DO NOT ALLOW THE EXCLUSION OR LIMITATION OF EXPRESS OR IMPLIED WARRANTIES, SO THE ABOVE EXCLUSION OR LIMITATION MAY NOT APPLY TO YOU. IN THAT EVENT, SUCH WARRANTIES ARE LIMITED IN DURATION TO THE WARRANTY PERIOD. NO WARRANTIES APPLY AFTER THAT PERIOD.**

### **Items Not Covered by Warranty**

IBM does not warrant uninterrupted or error-free operation of a Machine.

Unless specified otherwise, IBM provides non-IBM Machines **WITHOUT WARRANTIES OF ANY KIND.**

### **Warranty Service**

To obtain warranty service for the Machine, contact your reseller of IBM. In the United States, call IBM at 1-800-722-2227. In Canada, call IBM at 1-800-565-3344. You may be required to present proof of purchase.

IBM or your reseller provides certain types of repair and exchange service, either at your location or at a service center, to keep Machines in, or restore them to, conformance with their Specifica-

tions. IBM or your reseller will inform you of the available types of service for a Machine based on its country of installation. IBM may repair the failing Machine or exchange it at its discretion.

When warranty service involves the exchange of a Machine or part, the item IBM or your reseller replaces becomes its property and the replacement yours. You represent that all removed items are genuine and unaltered. The replacement may not be new, but will be in good working order and at least functionally equivalent to the item replaced. The replacement assumes the warranty service status of the replaced item.

Any feature, conversion, or upgrade IBM or your reseller services must be installed on a Machine, which is 1) for certain Machines, the designated, serial-numbered Machine and 2) at an engineering-change level compatible with the feature, conversion, or upgrade. Many features, conversions, or upgrades involve the removal of parts and their return to IBM. A part that replaces a removed part will assume the warranty service status of the removed part.

Before IBM or your reseller exchanges a Machine or part, you agree to remove all features, parts, options, alterations, and attachments not under warranty service.

You also agree to:

1. ensure that the Machine is free of any legal obligations or restrictions that prevent its exchange;
2. obtain authorization from the owner to have IBM or your reseller service a Machine that you do not own; and
3. where applicable, before service is provided
  - a. follow the problem determination, problem analysis, and service request procedures that IBM or your reseller provides,
  - b. secure all programs, data, and funds contained in a Machine,
  - c. provide IBM or your reseller with sufficient, free, and safe access to your facilities to permit them to fulfill their obligations, and

- d. inform IBM or your reseller of changes in a Machine's location.

IBM is responsible for loss of, or damage to, your Machine while it is 1) in IBM's possession or 2) in transit in those cases where IBM is responsible for the transportation charges.

Neither IBM nor your reseller is responsible for any of your confidential, proprietary or personal information contained in a Machine which you return to IBM or your reseller for any reason. You should return all such information from the Machine prior to its return.

### **Production Status**

Each IBM Machine is manufactured from new parts, or new and used parts. In some cases, the Machine may not be new and may have been previously installed. Regardless of the Machine's production status, IBM's appropriate warranty terms apply.

### **Limitation of Liability**

Circumstances may arise where, because of a default on IBM's part or other liability, you are entitled to recover damages from IBM. In each such instance, regardless of the basis on which you are entitled to claim damages from IBM (including fundamental breach, negligence, misrepresentation, or other contract or tort claim), IBM is liable for no more than

damages for bodily injury (including death) and damage to real property and tangible personal property; and

the amount of any other actual direct damages, up to the greater of U.S. \$100,000 (or equivalent in local currency) or the charges (if recurring, 12 months' charges apply) for the Machine that is the subject of the claim.

This limit also applies to IBM's suppliers and your reseller. It is the maximum for which IBM, its suppliers, and your reseller are collectively responsible.

**UNDER NO CIRCUMSTANCES IS IBM LIABLE FOR ANY OF THE FOLLOWING: 1) THIRD-PARTY CLAIMS AGAINST YOU FOR DAMAGES (OTHER THAN THOSE UNDER THE FIRST ITEM LISTED ABOVE); 2) LOSS OF, OR DAMAGE TO, YOUR RECORDS OR DATA; OR 3) SPECIAL, ACCIDENTAL, OR INDIRECT DAMAGES (INCLUDING LOST PROFITS OR SAVINGS), EVEN IF IBM, ITS SUPPLIERS OR YOUR RESELLER IS INFORMED OF THEIR POSSIBILITY. SOME JURISDICTIONS DO NOT ALLOW THE EXCLUSION OR LIMITATION OF INCIDENTAL OR CONSEQUENTIAL DAMAGES, SO THE ABOVE LIMITATIONS OR EXCLUSION MAY NOT APPLY TO YOU.**

### **IBM Statement of Warranty Worldwide except Canada, Puerto Rico, Turkey, United States (Part 1 - General Terms).**

---

This statement of Warranty includes Part 1 - General Terms and Part 2 - Country-unique Terms. **The terms of Part 2 may replace or modify those of Part 1.** The warranties provided by IBM in this Statement of Warranty apply only to Machines you purchase for your use, and not for resale, from IBM or your reseller. The term "Machine" does not include any software programs, whether pre-loaded with the Machine, installed subsequently or otherwise. Unless IBM specifies otherwise, the following warranties apply only in the country where you acquire the Machine. Nothing in this Statement of Warranty affects any statutory rights of consumers that cannot be waived or limited by contract. If you have any questions, contact IBM or your reseller.



**Machine** - IBM Portofino

**Warranty Period\*** - One year

*\*Contact your place of purchase for warranty service information. Some IBM Machines are eligible for On-site warranty service depending on the country where service is performed.*

### **The IBM Warranty for Machines**

IBM warrants that each Machine 1) is free from defects in materials and workmanship and 2) conforms to IBM's Official Published Specifications. The warranty period for a Machine is a specified, fixed period commencing on its Date of Installation. The date on your sales receipt is the Date of Installation, unless IBM or your reseller informs you otherwise.

During the warranty period IBM or your reseller, if approved by IBM to provide warranty service, will provide repair and exchange service for the Machine, without charge, under the type of service designated for the Machine and will manage and install engineering changes that apply to the Machine.

If a Machine does not function as warranted during the warranty period, and IBM or your reseller are unable to either 1) make it do so or 2) replace it with one that is at least functionally equivalent, you may return it to your place of purchase and your money will be refunded. The replacement may not be new, but will be in good working order.

### **Extent of Warranty**

The warranty does not cover the repair or exchange of a Machine resulting from misuse, accident, unsuitable physical or operating environment, improper maintenance by you, or failure caused by a

product for which IBM is not responsible. The warranty is voided by removal or alteration of Machine or parts identification labels.

**THESE WARRANTIES ARE YOUR EXCLUSIVE WARRANTIES AND REPLACE ALL OTHER WARRANTIES OR CONDITIONS, EXPRESS OR IMPLIED, INCLUDING, BUT NOT LIMITED TO, THE IMPLIED WARRANTIES OR CONDITIONS OF MERCHANTABILITY AND FITNESS FOR A PARTICULAR PURPOSE. THESE WARRANTIES GIVE YOU SPECIFIC LEGAL RIGHTS AND YOU MAY ALSO HAVE OTHER RIGHTS WHICH VARY FROM JURISDICTION TO JURISDICTION. SOME JURISDICTIONS DO NOT ALLOW THE EXCLUSION OR LIMITATION OF EXPRESS OR IMPLIED WARRANTIES, SO THE ABOVE EXCLUSION OR LIMITATION MAY NOT APPLY TO YOU. IN THAT EVENT, SUCH WARRANTIES ARE LIMITED IN DURATION TO THE WARRANTY PERIOD. NO WARRANTIES APPLY AFTER THAT PERIOD.**

### **Items Not Covered by Warranty**

IBM does not warrant uninterrupted or error-free operation of a Machine.

Unless specified otherwise, IBM provides non-IBM Machines **WITHOUT WARRANTIES OF ANY KIND.**

### **Warranty Service**

To obtain warranty service for the Machine, contact your reseller of IBM. In the United States, call IBM at 1-800-722-2227. In Canada, call IBM at 1-800-565-3344. You may be required to present proof of purchase.

IBM or your reseller provides certain types of repair and exchange service, either at your location or at a service center, to keep Machines in, or restore them to, conformance with their Specifica-

tions. IBM or your reseller will inform you of the available types of service for a Machine based on its country of installation. IBM may repair the failing Machine or exchange it at its discretion.

When warranty service involves the exchange of a Machine or part, the item IBM or your reseller replaces becomes its property and the replacement yours. You represent that all removed items are genuine and unaltered. The replacement may not be new, but will be in good working order and at least functionally equivalent to the item replaced. The replacement assumes the warranty service status of the replaced item.

Any feature, conversion, or upgrade IBM or your reseller services must be installed on a Machine, which is 1) for certain Machines, the designated, serial-numbered Machine and 2) at an engineering-change level compatible with the feature, conversion, or upgrade. Many features, conversions, or upgrades involve the removal of parts and their return to IBM. A part that replaces a removed part will assume the warranty service status of the removed part.

Before IBM or your reseller exchanges a Machine or part, you agree to remove all features, parts, options, alterations, and attachments not under warranty service.

You also agree to:

1. ensure that the Machine is free of any legal obligations or restrictions that prevent its exchange;
2. obtain authorization from the owner to have IBM or your reseller service a Machine that you do not own; and
3. where applicable, before service is provided
  - a. follow the problem determination, problem analysis, and service request procedures that IBM or your reseller provides,
  - b. secure all programs, data, and funds contained in a Machine,
  - c. provide IBM or your reseller with sufficient, free, and safe access to your facilities to permit them to fulfill their obligations, and

- d. inform IBM or your reseller of changes in a Machine's location.

IBM is responsible for loss of, or damage to, your Machine while it is 1) in IBM's possession or 2) in transit in those cases her IBM is responsible for the transportation charges.

Neither IBM nor your reseller is responsible for any of your confidential, proprietary or personal information contained in a Machine which you return to IBM or your reseller for any reason. You should return all such information from the Machine prior to its return.

### **Production Status**

Each IBM Machine is manufactured from new parts, or new and used parts. In some cases, the Machine may not be new and may have been previously installed. Regardless of the Machine's production status, IBM's appropriate warranty terms apply.

### **Limitation of Liability**

Circumstances may arise where, because of a default on IBM's part or other liability, you are entitled to recover damages from IBM. In each such instance, regardless of the basis on which you are entitled to claim damages from IBM (including fundamental breach, negligence, misrepresentation, or other contract or tort claim), IBM is liable for no more than:

1. damages for bodily injury (including death) and damage to real property and tangible personal property; and
2. the amount of any other actual direct damages, up to the greater of U.S. \$100,000 (or equivalent in local currency) or the charges (if recurring, 12 months' charges apply) for the Machine that is the subject of the claim.

This limit also applies to IBM's suppliers and your reseller. It is the maximum for which IBM, its suppliers, and your reseller are collectively responsible.

**UNDER NO CIRCUMSTANCES IS IBM LIABLE FOR ANY OF THE FOLLOWING: 1) THIRD-PARTY CLAIMS AGAINST YOU FOR DAMAGES (OTHER THAN THOSE UNDER THE FIRST ITEM LISTED ABOVE); 2) LOSS OF, OR DAMAGE TO, YOUR RECORDS OR DATA; OR 3) SPECIAL, ACCIDENTAL, OR INDIRECT DAMAGES (INCLUDING LOST PROFITS OR SAVINGS), EVEN IF IBM, ITS SUPPLIERS OR YOUR RESELLER IS INFORMED OF THEIR POSSIBILITY. SOME JURISDICTIONS DO NOT ALLOW THE EXCLUSION OR LIMITATION OF INCIDENTAL OR CONSEQUENTIAL DAMAGES, SO THE ABOVE LIMITATIONS OR EXCLUSION MAY NOT APPLY TO YOU.**

## **Part 2 - Worldwide Country-Unique Terms**

### **ASIA PACIFIC**

**AUSTRALIA: the IBM Warranty for Machines:** The following paragraph is added to this Section:

The warranties specified in this Section are in addition to any rights you may have under the Trade Practices Act 1974 or other legislation and are only limited to the extent permitted by the applicable legislation.

**Extent of Warranty:** The following replaces the first and second sentences of this Section: The warranty does not cover the repair or exchange of a Machine resulting from misuse, accident, modification, unsuitable physical or operation environment, operation in other than the Specified Operating Environment, improper maintenance by you, or failure caused by a product for which IBM is not responsible.

**Limitation of Liability:** The following is added to this Section:

IBM's liability is limited to the repair or replacement of the goods or the supply of equivalent goods. Where that condition or warranty relates to right to sell, quiet possession or clear title, or consumption, then none of the limitations in this paragraph apply.

**PEOPLE'S REPUBLIC OF CHINA: Governing Law:** The following is added to this Statement:

The Laws of the State of New York govern this Statement.

**INDIA: Limitation of Liability:** The following replaces items 1 and 2 of this Section:

1. liability for bodily injury (including death) or damage to real property and tangible personal property will be limited to that caused by IBM's negligence;
2. as to any other actual damage arising in any situation involving nonperformance by IBM pursuant to, or in any way related to the subject of this Statement of Warranty, IBM's liability will be limited to the charge paid by you for the individual Machine that is the subject of the claim.

**NEW ZEALAND: The IBM Warranty for Machines:** The following paragraph is added to this Section:

The warranties specified in this Section are in addition to any rights you may have under the Consumer Guarantees Act 1993 or other legislation which cannot be excluded or limited. The Consumer Guarantees Act 1993 will not apply in respect of any goods which IBM provides, if you require the goods for the purpose of a business as defined in that act.

**Limitation of Liability:** The following is added to this Section:

Where Machines are not acquired for the purposes of a business as defined in the Consumer Guarantees Act 1993, the limitations in this Section are subject to the limitations in that Act.

Limitations of Liability: The following is added to this Section:

Where Machines are not acquired for the purposes of a business as defined in the Consumer Guarantees Act 1993, the limitations in this Section are subject to the limitations in that Act.

### **EUROPE, MIDDLE EAST, AFRICA (EMEA)**

**The following terms apply to all EMEA countries.**

The terms of this Statement of Warranty apply to Machines purchased from an IBM reseller. If you purchased this Machine from IBM, the terms and conditions of the applicable IBM agreement prevail over this warranty statement.

#### **Warranty Service**

If you purchased an IBM Machine in Austria, Belgium, Denmark, Estonia, Finland, France, Germany, Greece, Iceland, Ireland, Italy, Latvia, Lithuania, Luxembourg, Netherlands, Norway, Portugal, Spain, Sweden, Switzerland or United Kingdom, you may obtain warranty service for that Machine in any of those countries from either (1) an IBM reseller approved to perform warranty service or (2) from IBM.

If you purchased an IBM Personal Computer Machine in Albania, Armenia, Belarus, Bosnia and Herzegovina, Bulgaria, Croatia, Czech Republic, Georgia, Hungary, Kazakhstan, Kirgizia, Federal Republic of Yugoslavia, Former Yugoslav Republic of Macedonia (FYROM), Moldova, Poland, Romania, Russia, Slovak Republic, Slovenia, or Ukraine, you may obtain warranty service for that Machine in any of

those countries from either (1) an IBM reseller approved to perform warranty service or (2) from IBM.

The applicable laws, country-unique-unique terms and competent court for this Statement are those of the country in which the warranty service is being provided. However, the laws of Austria govern this Statement if the warranty service is provided in Albania, Armenia, Belarus, Bosnia and Herzegovina, Bulgaria, Croatia, Czech Republic, Federal Republic of Yugoslavia, Georgia, Hungary, Kazakhstan, Kirghizia, Former Yugoslav Republic of Macedonia (FYROM), Moldova, Poland, Romania, Russia, Slovak Republic, Slovenia, and Ukraine.

**The following terms apply to the county specified:**

**EGYPT: Limitation of Liability:** The following replaces item 2 in this Section:

2. as to any other actual direct damages, IBM's liability will be limited to the total amount you paid for the Machine that is the subject of the claim.

Applicability of suppliers and resellers (unchanged).

**FRANCE: Limitation of Liability:** The following replaces the second sentence of the first paragraph of this Section:

In such instances, regardless of the basis on which you are entitled to claim damages from IBM, IBM is liable for no more than: (items 1 and 2 unchanged).

**GERMANY: The IBM Warranty for Machines:** The following replaces the first sentence of the first paragraph of this Section:

The warranty for an IBM Machine covers the functionality of the Machine for its normal use and the Machine's conformity to its Specifications.



The following paragraphs are added to this Section:

The minimum warranty period for Machines is six months.

In case IBM or your reseller are unable to repair an IBM Machine, you can alternatively ask for a partial refund as far as justified by the reduced value of the unrepaired Machine or ask for a cancellation of the respective agreement for such Machine and get your money refunded.

**Extent of Warranty:** The second paragraph does not apply.

**Warranty Service:** The following is added to this Section:

During the warranty period, transportation for delivery of the failing Machine to IBM will be at IBM's expense.

**Production Status:** The following paragraph replaces this Section:

Each Machine is newly manufactured. It may incorporate in addition to new parts, re-used parts as well.

**Limitation of Liability:** The following is added to this Section:

The limitations and exclusions specified in the Statement of Warranty will not apply to damages caused by IBM with fraud or gross negligence and for express warranty.

In item 2, replace "U.S. \$100,000" with "1,000,000 DEM".

The following sentence is added to the end of the first paragraph of item 2:

IBM's liability under this item is limited to the violation of essential contractual terms in cases of ordinary negligence.

**IRELAND: Extent of Warranty:** The following is added to this Section:

Except as expressly provided in these terms and conditions, all statutory conditions, including all warranties implied, but without prejudice to the generality of the foregoing all warranties implied by the Sale of Goods Act 1893 or the Sale of Goods and Supply of Services Act 1980 are hereby excluded.

**Limitation of Liability:** The following replaces items one and two of the first paragraph of this Section:

1. death or personal injury or physical damage to your real property solely caused by IBM's negligence; and 2, the amount of any other actual direct damages, up to the greater Irish Pounds 75,000 or 125 percent of the charges (if recurring, the 12 months' charges apply) for the Machine that is the subject of the claim or which otherwise gives rise to the claim.

Applicability of suppliers and resellers (unchanged).

The following paragraph is added at the end of this Section:

IBM's entire liability and your sole remedy, whether in contract or in tort, in respect of any default shall be limited to damages.

**ITALY: Limitation of Liability:** The following replaces the second sentence in the first paragraph:

In each such instance unless otherwise provided by mandatory law, IBM is liable for no more than: (item 1 unchanged) 2) as to any other actual damage arising in all situations involving non-performance by IBM pursuant to, or in any way related to the subject matter of this Statement of Warranty, IBM's liability, will be limited to the total amount you paid for the Machine that is subject of the claim.

Applicability of suppliers and resellers (unchanged).

The following replaces the second paragraph of this Section:

Unless otherwise provided by mandatory law, IBM and your reseller are not liable for any of the following: (items 1 and 2 unchanged) 3) indirect damages, even if IBM or your reseller is informed of their possibility.

**SOUTH AFRICA, NAMIBIA, BOTSWANA, LESOTHO, AND SWAZILAND: Limitation of Liability:** The following is added to this Section:

IBM's entire liability to you for actual damages arising in all situations involving nonperformance by IBM in respect of the subject matter of this Statement of Warranty will be limited to the charge paid by you for the individual Machine that is subject of your claim from IBM.

**TURKEY: Production Status:** The following replaces this Section:

IBM fulfils customer orders for IBM Machines as newly manufactured in accordance with IBM's production standards.

**UNITED KINGDOM: Limitation of Liability:** The following replaces items 1 and 2 of the first paragraph of this Section:

1. death or personal injury or physical damage to your real property solely caused by IBM's negligence;
2. the amount of any other actual direct damages or loss, up to the greater of Pounds Sterling 150,000 or 125 percent of the charges (if recurring, the 12 months' charges apply) for the Machine that is the subject of the claim or which otherwise gives rise to the claim.

The following item is added to this paragraph:

3. breach of IBM's obligations implied by Section 12 of the Sale of Goods Act 1979 or Section 2 of the Supply of Goods and Services Act 1982.

Applicability of suppliers and resellers (unchanged).

The following is added to the end of this Section:

IBM's entire liability and your sole remedy, whether in contract or in tort, in respect of any default will be limited to damages.

### **NORTH AMERICA**

**CANADA: Warranty Service:** The following is added to this Section:

To obtain warranty service from IBM, call **1-800-565-3344**.

**UNITED STATES OF AMERICA: Warranty Service:** The following is added to this Section:

To obtain warranty service from IBM, call **1-800-772-2227**.

