

# EZURiO

## BISM2 Bluetooth™ Version 2.0 Serial Module

### 1. General Description

Ezurio's BISM2 Bluetooth Serial Module is a fully integrated and qualified Class 1 Bluetooth solution designed for lowest cost of integration and ownership for designers wishing to incorporate Bluetooth functionality into their products. The module is qualified to Bluetooth Version 2.0.

The BISM2 Module is based on Cambridge Silicon Radio's BlueCore 04 chipset. The module contains all of the hardware and firmware for a complete Bluetooth solution, requiring no further components. The Module has an integrated, high performance antenna which is matched with the Bluetooth RF and baseband circuitry. The firmware integrated into the BC04 chipset implements the higher layer Bluetooth protocol stack, up to and including the Generic Access Profile (GAP), Service Discovery Profile (SDAP), Serial Port Profile (SPP), Dial Up Networking Profile (DUN) and Audio Gateway. A virtual processor is used within the BC04 to implement an AT command processor. This interfaces to the host system over a straight forward serial port using an extensive range of AT commands. The AT command set abstracts the Bluetooth protocol from the host application, saving many months of programming and integration time. It provides extremely short integration times for data oriented cable replacement and voice applications. A low cost development system is available for fast product evaluation and development.

An alternative version of firmware is available that provides programming support for multi-point applications.

The Module can be configured so that it can be attached to a 'dumb' terminal or attached to a PC or PDA for cable replacement applications.

In addition to the Bluetooth functionality, The BISM2 Module provides access to 8 General I/O lines and 2 analogue I/O lines. These can be configured to provide connection to simple devices such as switches or LEDs without requiring any external processing. Both the GPIO and ADC lines can be accessed either via the wired host UART connection, or remotely over the Bluetooth link.

The BISM2 module is supplied in a small form factor pcb (25mm x 35mm x 10mm), that connects to a main pcb using a 40 way Hirose connector. The module includes a high sensitivity, high gain antenna which provides excellent range. Typical open field performance provides ranges of over 250 metres at transmit powers of only 4mW.

Support is provided for low power modes that make the BISM2 particularly applicable to battery powered installations.

The BISM2 module is Lead-free and is RoHS compliant and supports an industrial temperature range of -40°C to +85°C.

#### 1.1 Applications

- POS Equipment
- Medical Equipment
- Telematics
- Voice Applications
- Industrial Automation
- Automotive Applications

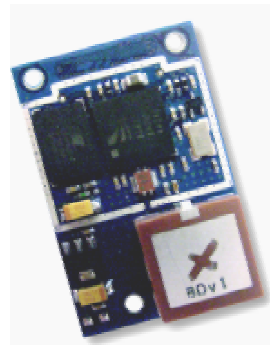

Bluetooth is a trademark owned by Bluetooth SIG, Inc., USA, and is licensed to Ezurio Ltd

## 2. Features

Feature	Implementation
Bluetooth Transmission	Class 1
Fully Bluetooth pre-qualified	Bluetooth 2.0
Range	250 metres typical (free space)
Frequency	2.400 – 2.485 GHz
Max Transmit Power	+6dBm
Min Transmit Power	+0dBm
Receive Sensitivity	Better than -90dB
Antenna Gain	+2dBi
Data Transfer rate	Up to 250Kbps
Serial Interface	RS-232 bi-directional for commands and data using AT commands
Serial parameters	Default 9600,n,8,1 - Configurable from 9600bps. Support for DTR, DSR, DCD, RI, RTS, CTS
Physical size	25 x 35 x 10 mm, 8g
Current consumption	Less than 36mA during data transfer with a configurable low power mode
Low power sniff mode	2.5mA typ
Temperature Range	Normal operation: -40°C to +85°C
Interface Levels	3.3V
Audio	Audio can be transferred over SCO channels through the PCM interface at 64kbps
Profiles	Server - SPP (Full), DUN, Audio Gateway, Headset, Handsfree Client - All RFCOMM based profiles
Multipoint	7 slaves
Field upgradeable	Over UART UART
Protocols	Single point firmware is controlled and configured using AT Commands, multipoint firmware uses a simple packet based protocol and requires a host to enable the module to function effectively. Single point only allows a point to point connection where as multipoint allows up to 7 simultaneous connections.
GPIO	8 x digital 2 x analogue
Lead free	Lead-free and RoHS compliant

### 3. Functional Block Diagram

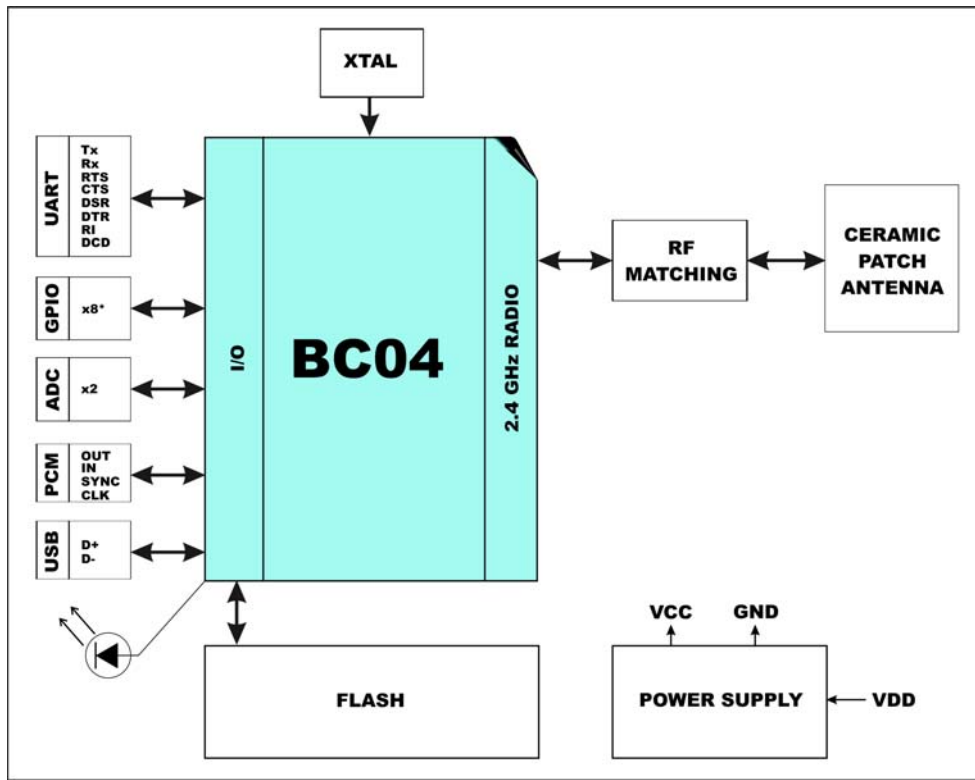

\* GPIO lines are utilised for DTR, DCD, RI and LED, but can be re-assigned

#### 3.1 Connection Diagram

The Module is equipped with a 40-pin 0.5mm pitch board-to-board connector that connects to the application platform.

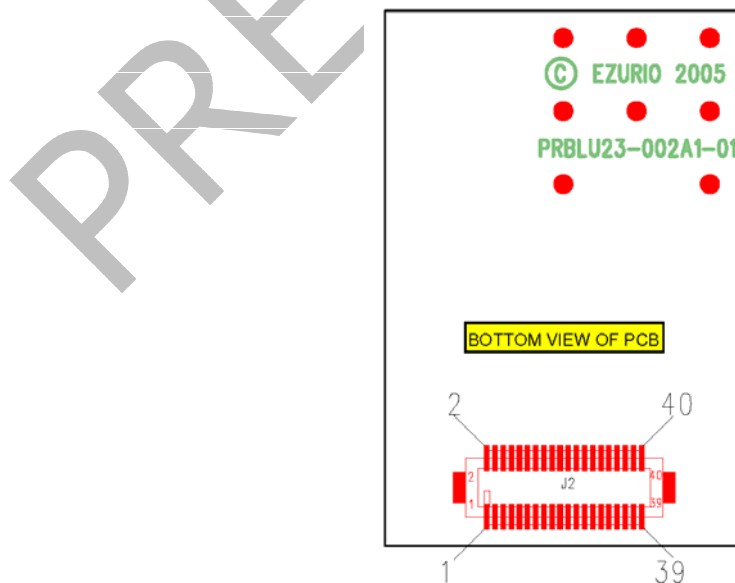

## 3.2 Pin Descriptions

The Hirose DF12C board-to-board connector on the module is a 40-pin double-row receptacle.

The table below defines the pin functions. Note that this pin-out is as viewed from the underside of the Module.

Pin No.	Signal	Description
1	Analogue 0	1.8v Max
3	Analogue 1	1.8v Max
5	SPI_MISO	SPI bus serial O/P
7	SPI_CSB	SPI bus chip select I/P
9	SPI_CLK	SPI bus clock I/P
11	GND	
13	RESET	Reset I/P
15	GND	
17	SPI_MOSI	SPI bus serial I/P
19	UART_CTS	Clear to Send I/P
21	UART_TX	Transmit Data O/P
23	UART_RTS	Request to Send O/P
25	UART_RX	Receive Data I/P
27	VCC_3V3	3.3V Output (Note 3)
29	VCC_5V	3.6V < VIN < 6.0V
31	N/C	
33	GPIO6	I/O for Host
35	GPIO7	I/O for Host
37	GPIO8	I/O for Host
39	RESERVED	DO NOT CONNECT

Pin No.	Signal	Description
2	GPIO1	I/O for Host.
4	GPIO2	I/O for Host
6	UART_RI	'Ring' Input or Output
8	UART_DCD	Input or Output
10	UART_DSR	Input
12	GPIO3/UART_DTR	I/O for Host
14	GPIO4	I/O for Host
16	GPIO5	I/O for Host
18	GND	
20	PCM_CLK	PCM Clock I/P
22	PCM_IN	PCM Data I/P
24	PCM_SYNC	PCM Sync I/P
26	PCM_OUT	PCM Data O/P
28	N/C	
30	GND	
32	RESERVED	Do not connect
34	RESERVED	Do not connect
36	GND	
38	GND	
40	N/C	

### Notes:

UART\_RX, UART\_TX, UART\_CTS, UART\_RTS, UART\_RI, UART\_DCD and UART\_DSR are all 3.3v level logic. For example, when RX and TX are idle they will be sitting at 3.3V. Conversely for handshaking pins CTS, RTS, RI, DCD, DSR a 0v is treated as an assertion.

Pin 6 (UART\_RI) is active low. It is normally 3.3v. When a remote device initiates a connection, this pin goes low. This means that when this pin is converted to RS232 voltage levels it will have the correct voltage level for assertion.

Pin 8 (UART\_DCD) is active low. It is normally 3.3v. When a connection is live this pin is low. This means that when this pin is converted to RS232 voltage levels it will have the correct voltage level for assertion.

Pin 10 (UART\_DSR) is an input, with active low logic. It should be connected to the DTR output of the host. When the BISM2 Module is in high speed mode (See definition for S Register 512), this pin should be asserted by the host to ensure that the connection is maintained. A deassertion is taken to mean that the connection should be dropped, or an online command mode is being requested.

The GPIO pins can be accessed using S Registers 621 to 625. GPIO4 and GPIO5 are also connected to LEDs on the module. If these I/O pins are set for input, then the LED will be driven by the host and

appropriate drive current requirements must be satisfied. By default GPIO4 is used to drive the right LED which indicates connection status. A Logic 1 switches on the LED.

GPIO3 is used for DTR output (active low).

Analogue 0 and 1 should not exceed 1.8v and S Registers 7xx are used to access them.

## 3.3 Electrical Specifications

### 3.3.1 Absolute Maximum ratings

Absolute maximum ratings for supply voltage and voltages on digital and analog pins of the Module are listed below; exceeding these values will cause permanent damage.

Parameter	Min	Max	Unit
Peak current of power supply	0	100	mA
Voltage at digital pins	-0.3	3.7	V
Voltage at POWER pin	3.3	7	V

### 3.3.2 Recommended Operating Parameters

#### 3.3.2.1 Power Supply

Signal Name	Pin No	I/O	Signal level	Comments
Vcc	29	I	3.6V to 6V	I <sub>typ</sub> = 50mA
GND	11, 15, 18, 30, 36, 38			6 Ground terminals to be attached in parallel
VCC_1V8	39	O	1.8V typical	For monitoring only. No current source
VCC_3V3	27	O	3.3V typical	For monitoring only. No current source

#### 3.3.2.2 RS-232 Interface

Signal Name	Pin No	I/O	Signal level	Comments
UART_TX	21	O	V <sub>OL</sub> max=0.2V V <sub>OH</sub> min=2.8V	
UART_RX	25	I	V <sub>IL</sub> max=0.8V V <sub>IH</sub> min=2.10V V <sub>IH</sub> max=3.7V	
UART_CTS	19	I	V <sub>IL</sub> max=0.8V V <sub>IH</sub> min=2.10V V <sub>IH</sub> max=3.7V	
UART_RTS	23	O	V <sub>OL</sub> max=0.2V V <sub>OH</sub> min=2.8V	
UART_DSR	10	I	V <sub>IL</sub> max=0.8V	

			$V_{IHmin}=2.10V$ $V_{IHmax}=3.7V$	
UART_DTR	12	O	$V_{OLmax}=0.2V$ $V_{OHmin}=2.8V$	Shared with GPIO3
UART_RI	6	I or O	O/P : $V_{OLmax}=0.2V$ $V_{OHmin}=2.8V$ I/P : $V_{ILmax}=0.8V$ $V_{IHmin}=2.10V$ $V_{IHmax}=3.7V$	Direction may be programmed.
UART_DCD	8	I or O	O/P : $V_{OLmax}=0.2V$ $V_{OHmin}=2.8V$ I/P : $V_{ILmax}=0.8V$ $V_{IHmin}=2.10V$ $V_{IHmax}=3.7V$	Direction may be programmed.

### 3.3.2.3 SPI Bus

Signal Name	Pin No	I/O	Signal level	Comments
SPI_MOSI	17	I	$V_{ILmax}=0.8V$ $V_{IHmin}=2.10V$ $V_{IHmax}=3.7V$	Used to reprogram Flash
SPI_MISO	5	O	$V_{OLmax}=0.2V$ $V_{OHmin}=2.8V$	
SPI_CSB	7	I	$V_{ILmax}=0.8V$ $V_{IHmin}=2.10V$ $V_{IHmax}=3.7V$	
SPI_CLK	9	I	$V_{ILmax}=0.8V$ $V_{IHmin}=2.10V$ $V_{IHmax}=3.7V$	

### 3.3.2.4 PCM Interface

Signal Name	Pin No	I/O	Signal level	Comments
PCM_CLK	20	I or O	O/P : $V_{OLmax}=0.2V$ $V_{OHmin}=2.8V$ I/P : $V_{ILmax}=0.8V$ $V_{IHmin}=2.10V$ $V_{IHmax}=3.7V$	If unused keep pins open
PCM_IN	22	I	$V_{ILmax}=0.8V$ $V_{IHmin}=2.10V$ $V_{IHmax}=3.7V$	
PCM_SYNC	24	I or O	O/P : $V_{OLmax}=0.2V$	

			$V_{OHmin}=2.8V$ I/P : $V_{ILmax}=0.8V$ $V_{IHmin}=2.10V$ $V_{IHmax}=3.7V$	
PCM_OUT	26	O	$V_{OLmax}=0.2V$ $V_{OHmin}=2.8V$	

### 3.3.2.5 General Purpose I/O and ADC

Signal Name	Pin No	I/O	Signal level	Comments
GPIO 1 - 5	2,4,12, 14,16	I or O	O/P : $V_{OLmax}=0.2V$ $V_{OHmin}=2.8V$ I/P : $V_{ILmax}=0.8V$ $V_{IHmin}=2.10V$ $V_{IHmax}=3.7V$	
AIO_0, AIO_1	1, 3	I/O	Vout max= $V_{DD\_PIO}-.3$ Vout min= $V_{DD\_PIO}$	

### 3.3.2.6 Miscellaneous

Function	Signal Name	Pin No	I/O	Signal level	Comments
Reserved	USB D-	32	I	$V_{ILmax} = 0.3v_{dd\_pads}$ $V_{IHmin} = 0.7v_{dd\_pads}$	Normally inactive. Pull to GND through 10K
Reserved	USB D+	34	I	$V_{ILmax} = 0.3v_{dd\_pads}$ $V_{IHmin} = 0.7v_{dd\_pads}$	Normally inactive. Pull to GND through 10K
Reset	RESET	13	I	VDD falling threshold= $1.5V$ typ VDD rising threshold= $1.6V$ typ	

## 4. I/O Characteristics

### 4.1 Power Consumption

The current drain from the Vcc power input line is dependent on various factors. The three most significant factors are the voltage level at Vcc, UART Baudrate and the operating mode.

The hardware specification for the Module allows for a voltage range of 3.6 to 6.0 at Vcc. Tests have shown that there is no significant difference in current draw when Vcc is 5 or 6V. Therefore the data presented below, pertains to Vcc levels of 3.6 and 5v only. Tests have shown that where power drain is an issue, it is best to keep Vcc at the lower end of the range.

The UART baudrate has a bearing on power drain because as is normal for digital electronics, the power requirements increase linearly with increasing clocking frequencies. Hence higher baudrates result in a higher current drain.

Finally with regards to operating mode the significant modes are; idle, waiting for a connection, inquiring, initiating a connection, sniff and connected. With connected mode, it is also relevant to differentiate between no data being transferred and when data is being transferred at the maximum rate possible. The AT command Set document describes how to configure the Module for optimal power performance.

#### 4.1.1 Typical Current Consumption in mA

	Vcc	Baudrate			
		9600	38400	115200	460800
Idle Mode, S512=1	3.6v	1.60	1.80	1.96	3.00
	5.0v	2.00	2.10	2.30	3.40
Wait for Connection Or Discoverable Mode, AT+BTP S508=S510=640, S509=S511=320	3.6v	59.00	59.00	59.00	59.00
	5.0v	65.00	65.00	65.00	65.00
Wait for Connection Or Discoverable Mode, AT+BTP S508=S510=1000, S509=S511=11*	3.6v	2.75	2.94	3.10	4.12
	5.0v	3.26	3.36	3.55	4.63
Inquiring Mode, AT+BTI	3.6v	50.00	50.00	50.00	50.00
	5.0v	54.00	54.00	54.00	54.00
Connecting Mode (ATDxxx)	3.6v	50.00	50.00	50.00	50.00
	5.0v	54.00	54.00	54.00	54.00
Connected Mode (No Data Transfer)	3.6v	6.00	6.10	6.40	7.20
	5.0v	7.20	7.20	7.40	8.20
Connected Mode (Max Data Transfer)	3.6v	21.50	22.50	24.50	32.50
	5.0v	24.50	26.00	28.00	36.00

\* Note: calculated figures

### 4.2 Interface Pins

To be supplied



## 5. DC Characteristics

### 5.1 RF Performance

#### 5.1.1 Transmit Power

<b>Conducted Transmit Power</b>	min: 1.0mW (0dBm)	max: 4mW (6dBm)
<b>Antenna Gain</b>	+2dBi typ.	
<b>Effective Transmit Power</b>	min: 0dBm max	Max: +6dBm

#### 5.1.2 Receive Sensitivity

<b>Receive Sensitivity</b>	-86dBm (at 25°C)
<b>Antenna Gain</b>	+2dBi typ
<b>Effective Receive Sensitivity</b>	-88dBm (at 25°C)

#### 5.1.3 RF Performance Data

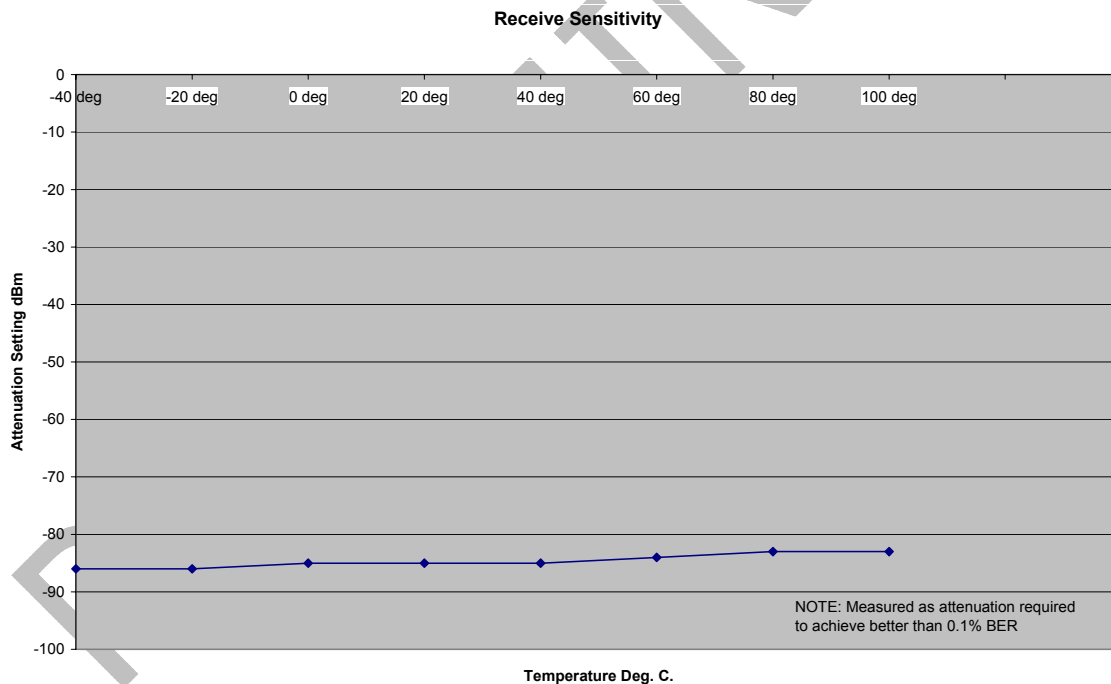

## 5.2 Range

See the Data Transfer Rate vs distance graph below. The data throughput of the Module is limited to 280Kbps by the parsing of the data being transferred through the AT command processor. The graph below shows the typical data throughput with and without the AT command processing. Distances are measured in free space between 2 Modules.

Data Transfer Rate / Distance

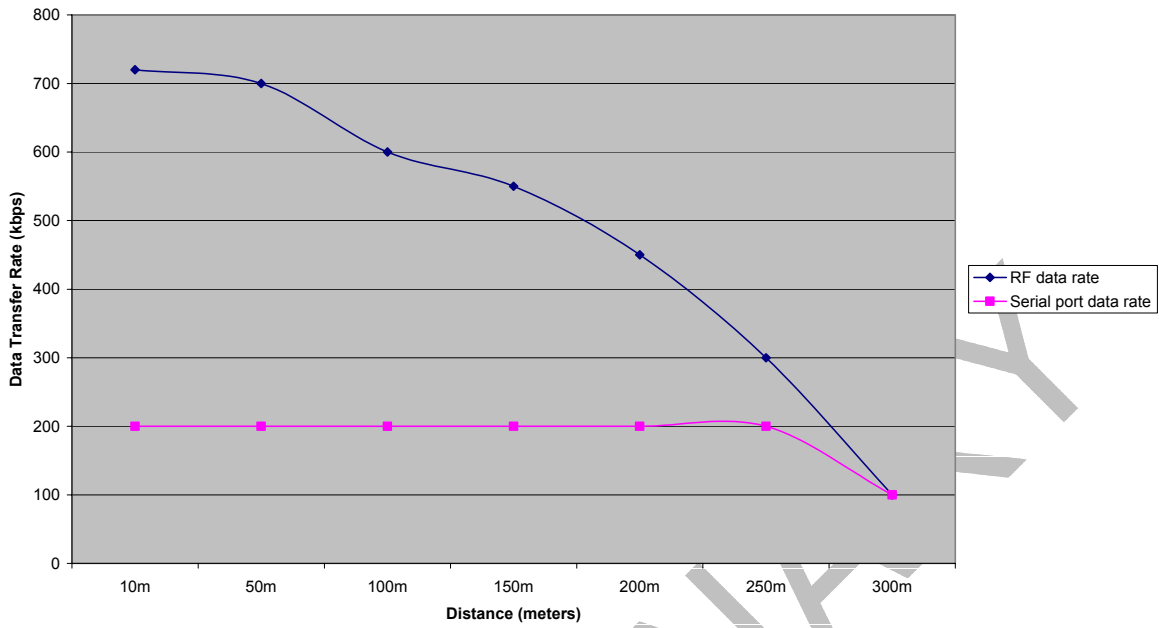

### 5.3 Temperature Performance

Data Transmit Rate with Temperature and Attenuation

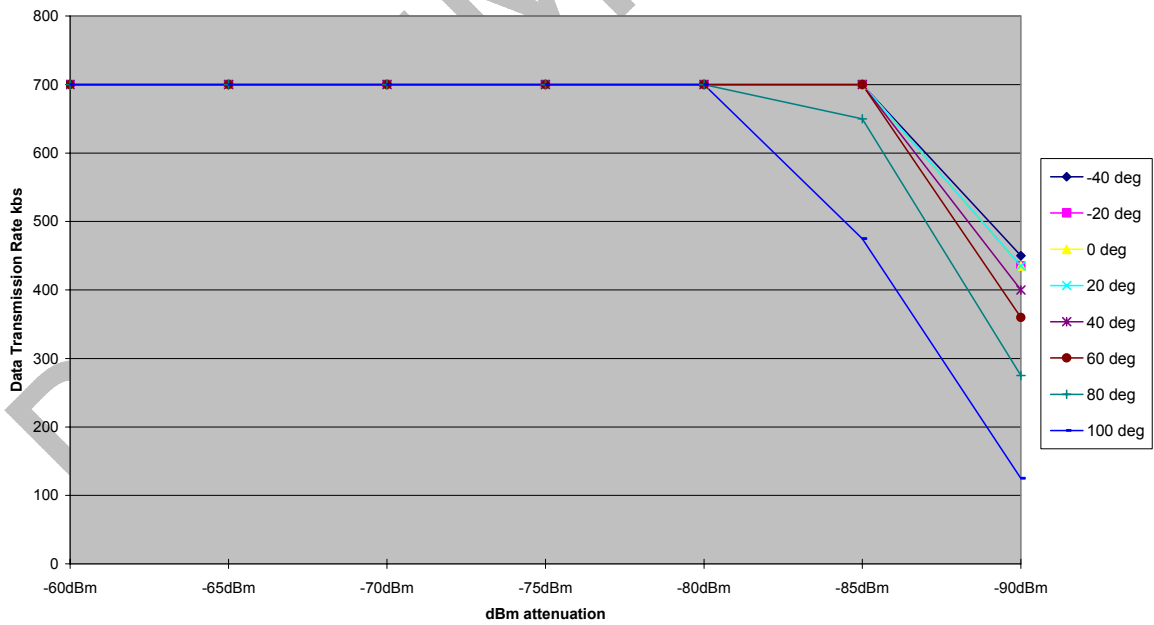

## 6. Functional Description

The BISM2 Bluetooth module is a self-contained Bluetooth product and requires only power to implement full Bluetooth communication. The integrated, high performance antenna together with the RF and Base-band circuitry provides the Bluetooth wireless link and the UART interface provides a connection to the host system.

The variety of interfaces and the AT command set allow the BISM2 module to be used for a wide number of short range wireless applications, from simple cable replacement to complex multipoint applications, where multiple radio links are active at the same time.

The complexity and flexibility of configuration are made simple for the design engineer by the integration of a extremely comprehensive set of AT commands, supplemented with a range of "S" registers which are used for non-volatile storage of system parameters. These are fully documented in the "Blu2i AT Command Reference Manual".

To provide the widest scope for integration a range of different physical host interfaces are provided:

### 6.1 Interfaces

#### 6.1.1 UART interface

UART\_TX, UART\_RX, UART\_RTS and UART\_CTS form a conventional asynchronous serial data port. The interface is designed to operate correctly when connected to other UART devices such as the 16550A. The signalling levels are nominal 0V and 3.3V and are inverted with respect to the signalling on an RS232 cable. The interface is programmable over a variety of bit rates; no, even or odd parity; stop bit and hardware flow control. The default condition on power-up is pre-assigned in the external Flash. Two-way hardware flow control is implemented by UART\_RTS and UART\_CTS. UART\_RTS is an output and is active low. UART\_CTS is an input and is active low. These signals operate according to normal industry convention.

By writing different values to the S register the UART\_RI can be continuously polled to detect incoming communication. The UART\_RI signal serves to indicate incoming calls.

UART\_DSR is an active low input. It should be connected to DTR output of the host. When the module is running in high speed mode (See definition for S Reg 512), this pin should be asserted by the host to ensure connection is maintained. A de-assertion is taken to mean that the connection should be dropped, or an online command mode is being requested.

The module communicates with the customer application using the following signals:

RS-232

Port /TXD @ application sends data to the module's UART\_RX signal line

Port /RXD @ application receives data from the module's UART\_TX signal line

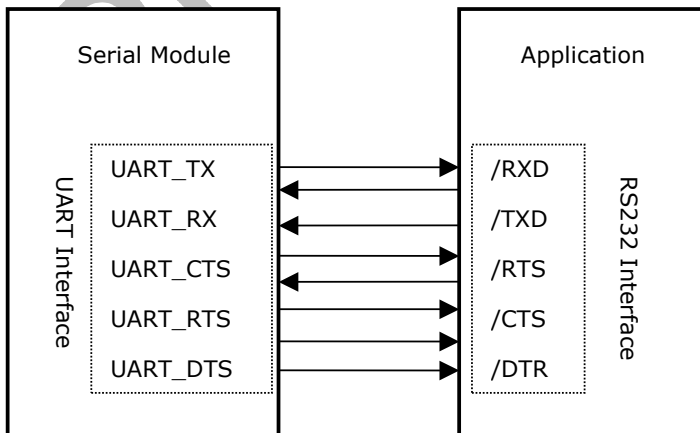

Figure 6.1 : UART interfaces

## 6.1.2 SPI bus

The Module is a slave device that uses terminals SPI\_MOSI, SPI\_MISO, SPI\_CLK and SPI\_CSB. This interface is used for program firmware update.

Note: The designer should be aware that no security protection is built into the hardware or firmware associated with this port, so the terminals should not be permanently connected in a PC application.

## 6.1.3 GPIO Port

Eight lines of programmable bi-directional input/outputs (I/O) are provided that can be accessed either via the UART port, or Over The Air from a second Bluetooth unit. These can be used as data inputs or to control external equipment. By using these in OTA mode, a BISM21 module can be used for control and data acquisition without the need for any additional host processor.

Each of the GPIO[1:8] ports can be independently configured to be either an Input or Output. A selection of ports can be accessed synchronously.

GPIO 1 and 2 can be configured as event counters.

The ports are powered from  $V_{CC}$ . The mode of these lines can be configured and the lines are accessed via S Registers 621 to 625.

Low latency I/O can be accessed by using Ezurio's I/O via enquiry process.

## 6.1.4 PCM CODEC Interface

PCM\_OUT, PCM\_IN, PCM\_CLK and PCM\_SYNC carry up to three bi-directional channels of voice data, each at 8ksamples/s. The format of the PCM samples can be 8-bit A-law, 8-bit  $\mu$ -law, 13-bit linear or 16-bit linear. The PCM\_CLK and PCM\_SYNC terminals can be configured as inputs or outputs, depending on whether the module is the Master or Slave of the PCM interface.

The Module is compatible with the Motorola SSI™ interface and interfaces directly to PCM audio devices including the following:

### 6.1.4.1 Compatible Codec Chips

- Qualcomm MSM 3000 series and MSM 5000 series CDMA baseband devices
- OKI MSM7705 four channel A-law and  $\mu$ -law CODEC
- Motorola MC145481 8-bit A-law and  $\mu$ -law CODEC
- Motorola MC145483 13-bit linear CODEC

## 6.1.5 ADC

The BISM2 provides access to two 8-bit ADCs are available. These provide a range of 0mV to 1,800mV, which can be read using the S registers 701 and 702.

Suitable external scaling and over-voltage protection should be incorporated in your design.

## 6.1.6 Pass Through Serial

To be supplied

# 7. Integrated Firmware

## 7.1 General

The BISM2 has been designed to provide the fastest route to market for designers who wish to use Bluetooth to wirelessly enable their products. To achieve this Ezurio has implemented a wide ranging set of AT commands that control all of the standard Bluetooth tasks. These remove the complexity of Bluetooth from the design engineer and allow the wireless link to be controlled by means of a simple set of commands.

For applications where multiple concurrent live connections need to be maintained a variant of firmware is available which is specifically targeted at multipoint operation.

For both applications a comprehensive range of windows based software and is available to speed up the design process. A low cost development kit is also available that can be used for prototyping both cable replacement and multipoint applications.

## 7.2 Profiles

Bluetooth has been designed to accommodate a very wide range of wireless applications. To enable these different applications the Bluetooth SIG (Special Interest Group) has defined a series of different profiles that define the way in which Bluetooth devices communicate with each other and perform basic functions. These provide a base line of interoperability for specific application scenarios, upon which more complex user applications can be developed.

There are over 30 different profiles, many of which have been developed for specific applications. The BISM2 firmware is provided with support for the profiles that are most commonly required for cable replacement applications.

The current profiles support includes:

- GAP Generic Access Profile. The base connection profile upon which others are based.
- SDP Service Discovery Profile. The profile to find other Bluetooth devices and the services they support.
- SPP Serial Port Profile. Emulation of a serial cable for cable replacement applications.
- DUN Dial Up Networking. Profile support for connection to an external PSTN, GSM, GPRS or VPN connection.
- Audio Gateway. The base element for Headset and Handsfree profile. A portion of these profiles must be implemented within the host system.

For other profile support, please contact Ezurio Ltd at [blu2i@ezurio.com](mailto:blu2i@ezurio.com)

## 7.3 AT Overview

The AT command set is well known by engineers and was developed to aid the integration of PSTN modems. It provides simple high level commands for complex functions that can easily be incorporated into programs or used within programming scripts.

Ezurio has used this familiar concept and extended it to Bluetooth to simplify the integration of Bluetooth for product designers. Rather than having to understand the many stages of setting up a Bluetooth connection or function, a single AT command is all that is required.

For example to connect to a Bluetooth device with an address 00809844EA13, all that is needed is to send the string

```
ATD00809844EA13
```

to the UART of the BISM2 module. The module will attempt to make a connection and return OK or ERROR, depending on whether the connection was successful.

The complexity of the AT command set developed by Ezurio is such that most Bluetooth functionality can be covered, greatly reducing development time.

To provide additional functionality a range of "S" registers has been implemented. These allow program settings to be stored to control the BISM2 function and also give access to configuring and reading ports and status registers within the BISM2.

Full details of the AT command set are provided in the Blu2i AT Command Reference Manual.

## **7.3.1 AT features at a glance**

### **7.3.1.1 General**

- Configure two modules to automatically connect and transfer data, audio or a combination of data and audio when both devices are powered.
- Automatically re-connect devices when a connection is dropped.
- Remotely access the AT parser of the remote unit from a master device to perform Over The Air (OTA) configuration.
- Configure the module to enter a state on power up and after a period of time change to another state automatically
- Read and write to GPIO lines
- Read the ADC channels
- Get fast GPIO status through an inquiry response (patent pending)

### **7.3.1.2 Audio**

- Set up audio connections
- Enable / disable Auto Answer for incoming connections

### **7.3.1.3 UART**

- Change the baud rate from 1200 to 961,200 baud.
- Use the DSR line to drop connections
- Configure as DTE or DCE
- Change escape sequence character
- Change the number of Stop bits and Parity
- Enable or disable echoes

### **7.3.1.4 Security**

- Enable Authentication by requiring a PIN code for incoming AND / OR outgoing connections
- Enable data to be encrypted over the air for incoming AND / OR outgoing connections. The module can be configured to be:
  - non-connectable and non-discoverable,
  - non-connectable but discoverable,
  - connectable but non-discoverable,
  - connectable and discoverable.
- Automatically store Paired devices in a trusted device database in the flash memory

### **7.3.1.5 Bluetooth**

- Set the module to be a master or slave
- Make a Bluetooth connection to a specified device
- Perform a full inquiry for other Bluetooth devices
- Query a remote device to check if a service is offered
- Fetch the friendly name of a remote device

- Increase or decrease the delay before the master abandons a connection attempt
- Change the device class code
- Set the device's friendly name
- Change the Inquiry scan time
- Change number of returned devices from an inquiry scan
- Obtain the RSSI value for a connection

#### **7.3.1.6 Power Management**

- Decrease or increase the output power to suit your connection range
- Configure the modules to work in Sniff and other low power modes.

## **7.4 Multipoint Firmware**

The Module consists of the same hardware as that used for the single point 'AT' blu2i module described elsewhere. Whereas the latter only allows one-to-one connection, the module described here allows simultaneous connections to a minimum of 3 slaves, and depending on hardware build, up to 7 slaves. It also allows connections to multiple profiles to one or more slaves. Hence this document adopts a concept of channels instead of slave connections.

The term 'host' in this document is taken to mean any entity which is a source of command messages, sink for response/event messages and both source and sink for multiplexed data packets.

## **7.5 OTA (Over the Air) Configuration**

When the BISM2 is placed in slave mode it's settings can be remotely controlled by a master unit. This places the slave unit's AT parser in remote mode providing over the air configuration. This mode is of use for remote sensor applications, where no host processor is required to control the slave Bluetooth unit.

## **7.6 Bootmodes**

The module has the capability of booting into 1 of 8 modes. These will be supported in future releases of firmware and selected via an S Register.

Boot Mode 1 is default and gives functionality equivalent to the BISM1 module.

These modes will specify different PSKEY settings to allow for different basic operation. Please contact Ezurio for further information.

# **8. Low Power Modes**

The current drain from the Vcc power input line is dependent on various factors. The three most significant factors are the voltage level at Vcc, UART baud rate and the operating mode.

The hardware specification for the blu2i module allows for a voltage range of 3.6 to 6.0v at Vcc. Tests have shown that there is no significant difference in current draw when Vcc is 5 or 6V. Therefore the data presented below, pertains to Vcc levels of 3.6 and 5v only. Tests have shown that where power drain is an issue, it is best to keep Vcc at the lower end of the range.

The UART baud rate has a bearing on power drain because as is normal for digital electronics, the power requirements increase linearly with increasing clocking frequencies. Hence higher baud rates result in a higher current drain.

Finally with regards to operating mode the significant modes are; idle, waiting for a connection, inquiring, initiating a connection and connected. With connected mode, it is also relevant to differentiate between no data being transferred and when data is being transferred at the maximum rate possible.

The operating mode can best be described by stating the AT commands required to enter that mode. In addition, there are certain S Registers which have a direct impact on power consumption, which are described next.

The blu2i Module has 2 LEDs which can be configured to display connection status. One led is used to display connection status, while the other is used to either display 'Ring Indicate' status or follow the state of the incoming DSR line on the UART interface. Tests have shown that these LEDs can consume up to 5.3mA which is more than double the current draw when in Idle mode. Therefore S Registers 533 and 534 can be used to completely disable these indications.

Finally S Registers 508 to 511, which specify the page and inquiry scan intervals and windows, can be used to adjust the average current drain when in discoverable and or connectable modes. Registers 508 and 509 specify the interval and window for page scans and registers 510 and 511 specify the interval and window for inquiry scans. Register pairs 508/509 and 510/511 describe duty cycles when the blu2i module goes into scan modes. It is while scanning that the highest current draw occurs. The average current draw is determined by simple arithmetic using the values stored in the 508/509 and 510/511 register pairs.

The operating modes described above are entered using AT commands as follows

Idle	On power up, with S Register 512 = 1
Wait for Connection	AT+BTG (100% page scan duty cycle)
Discoverable Only	AT+BTQ (100% inquiry scan duty cycle)
Connecting	ATD
Connected	No Data
Connected	Max data transfer

All current consumption values in the table below assume that the connection status indication functionality of the LED has been disabled by setting S Registers 533 and 534 to 0.

		Baud rate			
		9,600	38,400	115,200	460,800
Idle Mode, S512=1	3.6V	1.60	1.80	1.96	3.00
	5.0V	2.00	2.10	2.30	3.40
Wait for Connection Or Discoverable Mode, AT+BTP S508=S510=640, S509=S511=320	3.6V	59.00	59.00	59.00	59.00
	5.0V	65.00	65.00	65.00	65.00
Wait for Connection Or Discoverable Mode, AT+BTP S508=S510=1000, S509=S511=11	3.6V	2.75	2.94	3.10	4.12
	5.0V	3.26	3.36	3.55	4.63
Inquiring Mode, AT+BTI	3.6V	50.00	50.00	50.00	50.00
	5.0V	54.00	54.00	54.00	54.00
Connecting Mode (ATDxxx)	3.6V	50.00	50.00	50.00	50.00
	5.0V	54.00	54.00	54.00	54.00
Connected as Master Mode (No Data Transfer) Sniff NOT activated	3.6V	6.00	6.10	6.40	7.20
	5.0V	7.20	7.20	7.40	8.20



Connected as Master Mode (Max Data Transfer) Sniff NOT activated	3.6V	21.50	22.50	24.50	32.50
	5.0V	24.50	26.00	28.00	36.00
Connected as Slave Mode (No Data Transfer)	5.0V	32.00	33.00	33.50	34.00
Connected as Slave Mode (No Data Transfer) Sniff Enabled (AT&F1 setting)	5.0V	4.90			

All current values are in milliamps (mA).

As can be seen, the current drain while waiting for a connection or discoverable mode is about 30 times higher than in idle mode. This is when the page/inquiry scan duty cycle is 100%. These modes give the quickest response to a page or inquiry request from a remote peer.

It is possible to reduce the duty cycle down to as low as 0.5% at the expense of response time. The response time can be specified via S Registers 508 and 510 for page and inquiry respectively, where the worst case response time can be as high as 2.5 seconds. Then the duty cycle can be varied by changing the value of S Registers 509 and 511 appropriately.

For example, if S Register 508 and 510 are both set to 1000ms and S Register 509 and 511 are both set to 11ms then the duty cycle is reduced to 1%, this means that average current drain at 5.0v will be 2% of 65mA plus the normal idle mode current, that is, it is as low as 2.75mA. However, in this case, it can take up to 1 second to establish a connection.

The connected state current consumption while a master or slave can be considerably reduced by enabling Sniff mode, described in detail in the next section.

	mA	
Current per LED (when fitted)	3.6V	3.20
	5.0V	5.30

## 8.1 Low Power Modes using Sniff

Bluetooth connections are master/slave in nature. A master sends packets and a slave has to acknowledge that packet in the next timeslot. Timeslots in Bluetooth are 625 microseconds wide. This implies that a master will always know when packets will be sent and received, which further means it is able to optimise power usage by switching on power hungry circuitry only when needed.

A slave on the other hand does NOT have prior knowledge of when a packet will be received and has to assume that a packet will be received from a master on every receive slot. This means that it has to leave its receiving circuitry on for most of the receive slot duration. The result of this is high power consumption as illustrated in the power table above, where a slave with no data transmission still consumes around 31mA whereas a master consumes only 6mA.

This problem was identified very early in the evolution of Bluetooth (especially since headsets spend all their time as a slave in a Bluetooth connection) and it was solved by having a mode called Sniff, with appropriate lower layer negotiating protocol.

Sniff mode during connection is basically an agreement between the slave and its master that data packets will only be exchanged for N timeslots every M slots. The slave can then assume that it will never be contacted during N-M slots, and so can switch its power hungry circuitry off. The specification goes further by also specifying a third parameter called 'timeout' (T) which specifies 'extra' timeslots that the slave will agree to listen for after receiving a valid data packet. Put another way, if a data packet is received by the slave, then it knows that it MUST carry on listening for at least T more slots. If within that T slot time period another data packet is received, then the timer is restarted. This mechanism ensures low power consumption when there is no data transfer – at the

expense of latency. When there is a lot of data to be transferred, it acts as if sniff mode were not enabled.

It is stated above that during sniff mode, a slave listens for N slots every M slots. The Bluetooth specification states that a master can have up to 7 slaves attached to it with all slaves having requested varying sniff parameters. It may therefore be impossible to guarantee that each slave gets the M parameter it requested. In light of this, the protocol for enabling sniff mode specifies that a requesting peer specify the M parameter as a minimum and maximum value. This will allow the master to interleave the sniff modes for all slaves attached.

For this reason, the sniff parameters are specified in the BISM2 module via four S registers. S Register 561 is used to specify 'N', S Register 562 is used to specify 'T' and S Registers 563/564 are used to specify minimum 'M' and maximum 'M' respectively. Although the specification defines these parameters in terms of timeslots, the S register values have to be specified in units of milliseconds and the firmware does the necessary translation to timeslots.

**Error! Objects cannot be created from editing field codes.**

## 9. Application Examples

### 9.1 RS232 Modem Signals

Just as a telephony modem has control and status lines, the blu2i Module also provides for 6 control and status lines as per the table below. The direction column is as seen from the module's viewpoint.

Direction	Function
IN or OUT	CI also known as RI (Ring Indicate)
IN or OUT	DCD (Data Carrier Detect)
IN	DSR (Data Set ready)
OUT	DTR (Data Terminal Ready)
IN	CTS (Clear to Send)
OUT	RTS (Request to Send)

The first four lines are under program control. These use four of the GPIO pins and are mapped to I/O as per the table below. The last two are under control of the UART driver and their functionality is always enabled.

PIO Pin	Direction	Connector Pin Label	Function
0	IN/OUT	GPIO1	General Purpose I/O
1	IN/OUT	GPIO2	General Purpose I/O
2	IN/OUT	UART_RI	Input/Output from module
3	IN/OUT	UART_DCD	Input/Output from module
4	IN	UART_DSR	Input to Module
5	IN/OUT	GPIO3/UART_DTR	General Purpose I/O (or DTR functionality)
6	IN/OUT	GPIO4	General Purpose I/O (Right LED)
7	IN/OUT	GPIO5	General Purpose I/O (Left LED)

Notes:

1. PIO4 (DSR) is used by the blu2i module to sense that the host is connected, and is intricately linked with connections. For outgoing calls, if this line is not asserted then an error is indicated. Similarly for AT+BTP and AT+BTG.

While in a call, for appropriate modes, a de-assertion means fall into command state. If the de-assertion exists for longer than the period specified in S Register 519 then the connection is dropped as if an ATH command was received.

2. PIO2 (RI), is normally de-asserted. When an incoming connection is detected it will be asserted, until the connection is either answered or rejected using ATA and ATH respectively. See S Registers 552 & 553 for more details

3. PIO3 (DCD) will be de-asserted when the device is in the unconnected state. Asserted when a connection is active. See S Registers 552 and 553 for more details.

4. PIO5 is either used as GPIO or driven as UART\_DTR. When the unit is configured in pure host mode, this pin is forced into UART\_DTR and is asserted when there is a Bluetooth connection.

GPIO Pins 1,2,3,4 and 5 are available for general purpose use.

## 9.2 Modem signalling over Bluetooth

The RFCOMM protocol used in Bluetooth for implementing the serial port profile allows for the exchange of four modem signals. This information is contained in a special transparent message which contains bits identified as RTR, RTC, DV and IC which depending on the type of serial device being emulated maps to DTR or DSR, RTS, DCD and RI respectively. In addition, this message also includes the ability to convey a BREAK input from one end to the other.

To allow for the greatest flexibility and variability in how the modem control signals are used out in the real world, S Registers 551, 552 and 553 have been provided which allow for any of RTR,RTC,DV and IC to be mapped to any modem control/status line.

### **BREAK signal on RX line**

If the host sends a break signal of duration greater than 100ms, then the blu2i module is configured to treat that as a signal to perform a hardware reset.

This being the case it is not possible to convey a BREAK over Bluetooth to the peer device.

### **Reset**

The module can be reset by the host without the need of any I/O using a BREAK signal. The module has been configured to reset when the RX line detects a break condition for durations greater than 100 milliseconds.

## 9.3 Pure Cable Replacement Mode

The module has the capability of being preset into a pure 5-wire data cable replacement mode. The 5 wires being RX, TX, CTS, RTS and GND. This mode requires no changes to a host application since the Bluetooth connection is automatically set up on power up. If the connection is lost the BISM2 module will constantly retry until the connection is reinstated.

By implication, two devices are needed to replace a cable. One device is pre-configured to always be a master and the other, a slave.

Assuming the Bluetooth address of the master to be <bdaddr\_m> and that of the slave to be <bdaddr\_s>, the master module is configured by sending it the following AT commands:

```
AT&F
ATS512=1
ATS504=1
ATS507=2
ATS530=2000
AT&W
AT+BTR<bdaddr_s>
```

The ATS507=2 setting puts the device in DSR drop mode only. This means that when the device needs to be reconfigured, deasserting the DSR line will ensure that the module responds quickly to AT commands. This further means that in stand alone mode, the DSR input line MUST be asserted e.g. 0V in TTL signal mode.

The slave is configured by:

```
AT&F
ATS512=4
ATS0=-1
AT&W
AT+BTR<bdaddr_m>
```

Where <bdaddr\_m> is optional. If it is not specified, then the slave unit will accept connections from any device. If specified then only connections from the device specified will be accepted.

If it is desired that the slave unit should not be discoverable (the master is by default not discoverable), then the configuration commands are:

```
AT&F
ATS512=3
ATS0=-1
AT&W
AT+BTR<bdaddr_m>
```

Where <bdaddr\_m> is optional. If it is not specified, then the slave unit will accept connections from any device. If specified then only connections from the device specified will be accepted.

When the units are next power cycled, the slave unit will wait for the master to connect to it and the master will continually look for the slave. If a connection attempt fails, the master will wait for 2 seconds before reattempting a connection. This 2 second delay can be varied by issuing it an ATS530 command with an appropriate value in the range 100ms to 15000ms.

**IMPORTANT NOTE:** When S Register 507 = 0, the DSR input to the module MUST be asserted for the auto connection to succeed. When operating at TTL levels a 0V is seen as an assert state. When operating at RS232 levels and voltage greater than 3V is seen as assert. It is usual to connect the DTR line of the host to the DSR line of this device.

## 9.4 Audio Cable (voice)

With a pair of these modules it is possible to replace a mono audio cable with two way traffic. That is, a setup where a microphone is connected to a speaker at the remote end and vice versa. So this mode effectively replaces two audio cables.

Assuming the Bluetooth address of the master to be <bdaddr\_m> and that of the slave to be <bdaddr\_s>, the master module is configured by sending it the following AT commands:

```
AT&F
ATS512=1
ATS504=1
```

```
ATS530=2000
ATS532=1
AT&W
AT+BTR<bdaddr_s>
```

And the slave is configured by:

```
AT&F
ATS512=4
ATS0=-1
AT&W
AT+BTR<bdaddr_m>
```

## 9.5 Modem Control and Status Signals

A serial port has DTR, DSR, RTS, CTS, DCD and RI control lines. RTS and CTS are locally controlled to prevent local buffer overflow.

However the status of DTR, DRS, DCD and RI can be exchanged with the remote peer device. If for example, the DTR/DSR lines are to be exchanged between the two peers to simulate the performance of a physical cable, then it is possible to do so. Refer to the description for S Registers 551, 552 and 553 for more details.

## 10. Application Information

### 10.1 Antenna Position

The antenna used on the BISM2 Bluetooth module is designed to be largely immune from the effects of proximity detuning. Normally, antennas operating at 2.4GHz are affected by their surroundings, so that great care is needed in their placement and orientation.

The BISM2 can be used in most locations and orientations and is only marginally affected by the presence of a significant ground plane in close proximity.

The antenna distribution is close to isotropic, which means that the orientation of mounting has only a limited effect on the overall range. However the optimum range is achieved when the two antennae are directly facing each other

The module should not be located in a sealed metal enclosure, as this will act as a Faraday cage and prevent the radio signal from penetrating.

### 10.2 Power Supply Considerations

The power supply for the Module has to be a single voltage source of Vcc within the range of 3.3 V to 6.0 V. It must be able to provide sufficient current in a transmit burst. This can rise to 65mA.

The Module includes regulators to provide local 3.3V. This rail is accessible on connector J2 for monitoring purposes only. Under no circumstances should this pin be used to source current.

Power (Vcc) can be provided via the board-to-board connector Pin 29 on J2.

### 10.3 Power-On-Reset (Power Cycling and Brown Out considerations).

The Module is provided with an active low reset pin (Hirose 40way DF12C connector pin 13). Upon the application of power, the Power On Reset circuit built into the Module will ensure that the unit starts correctly. There is no need for an external power reset monitor.

### 10.4 Mounting the Module onto the application platform

There are many ways to properly install the Module in the host device. An efficient approach is to mount the PCB to a frame, plate, rack or chassis. Fasteners can be M1.8 or M2 screws plus suitable washers, circuit board spacers, or customized screws, clamps, or brackets in 2.2mm diameter holes. Note that care should be taken to ensure the head of the fixing does not interfere with the circuit. Nylon fixings are recommended. In addition, the board-to-board connection can also be utilized to achieve better support.

The antenna (Brown square component on top side of PCB) must not be influenced by any other PCBs, components or by the housing of the host device. The proximity of the antenna to large metallic objects can affect the range and performance of the system. Designers should carefully consider the location of the Module and the type of enclosure material that is used.

To prevent mechanical damage, be careful not to force, bend or twist the Module. Be sure it is positioned flat against the host device.

# 11. Board to Board Connector

This chapter provides specifications for the 40-pin board-to-board connector which serves as physical interface to the host application. The receptacle assembled on the Module is Hirose type DF12C. Details are available at: <http://www.hirose.co.jp/cat2002e/500/e53700036.pdf>

## 11.1 Stacking Height

Mating headers from Hirose are available in different stacking heights, allowing the spacing between the BISM2 and carrier pcb to be changed from 3.5mm to 5.0mm.

Item	Part number	Stacking height	HRS number
Receptacle on Module	DF12C-40DS-0.5V(81)	3.5 mm – 5 mm	CL537-0007-7-
Headers DF12 series	DF12(3.5)-40DP-0.5V(81)	3.5 mm	CL537-0032-4-**-
	DF12(4.0)-40DP-0.5V(81)	4.0 mm	CL537-0057-5-**-
	DF12(5.0)-40DP-0.5V(81)	5.0 mm	CL537-0157-0-**-

Notes: The headers listed above are without boss and metal fitting.

## 11.2 Hirose Connector general specification

Parameter	Specification (40 pin Board to Board connector)
Number of Contacts	40
Quantity delivered	2000 Connectors per Tape & Reel
Voltage	50V
Current Rating	0.5A max per contact
Resistance	0.05 Ohm per contact
Dielectric Withstanding Voltage	500V RMS min
Operating Temperature	-45°C...+125°C
Contact Material	phosphor bronze (surface: gold plated)
Insulator	Material PA , beige natural
Stacking height	3.0 mm ; 3.5 mm ; 4.0 mm ; 5.0 mm
Insertion force	21.8N
Withdrawal force 1st	10N
Withdrawal force 50th	10N
Maximum connection cycles	50

# 12. Qualification

## 12.1 Bluetooth Qualification Process

The following safety precautions must be observed during all phases of the operation, usage, service or repair of any application incorporating this Module. Manufacturers of the RF equipment are advised to convey the following safety information to users and operating personnel and to incorporate these guidelines into all manuals supplied with the product. Failure to comply with these precautions violates safety standards of design, manufacture and intended use of the product. Ezurio assumes no liability for customer failure to comply with these precautions.

## 12.2 Safety Information:

Switch off the Bluetooth device before boarding an aircraft. Make sure it cannot be switched on inadvertently. The operation of wireless appliances in an aircraft is forbidden by many airlines to prevent interference with communications systems. Applications that could result in use on aircraft should carry appropriate warnings.

## 12.3 Qualifications

### 12.3.1 RF approvals

The Module is listed as a Bluetooth Product in terms of the Bluetooth SIG Program Reference Document (PRD). This means that it can be integrated into end products without further testing or approval listing. The manufacturer must state the Ezurio part number and product reference in his literature in order to meet the requirements of the Bluetooth and regulatory approvals.

A list of the countries where the Module is approved will be provided by Ezurio as required. As a minimum the product is listed in Europe and USA. Ezurio assumes no liability for customer failure to comply with national RF approvals.

#### 12.3.1.1 Radio.

R&TTE EN 300 328-2 V1.1.1 (2000-07)

EN 301 489-1 V1.3.1 (2001-09)

#### 12.3.1.2 EMC Emissions.

FCC15B Class B

EN55022 Class B

#### 12.3.1.3 EMC Immunity.

EN55024 Class

#### 12.3.1.4 Environmental.

EN301 489-1 V1.3.1 (2001-09)

#### 12.3.1.5 Medical

EN60601-1-2

#### 12.3.1.6 Automotive

Emission test to 95/54/EC



## **12.4 Safety and Regulatory Statements**

### **12.4.1 Europe – EU Declaration of Conformity**

# **EZURiO**

#### **DECLARATION OF CONFORMITY**

In accordance with Annex IV of the EU directive 1999/5/EC

Notified Body consulted: Phoenix Test-Lab

ID-Number of Notified Body: 0700

declare under our responsibility that the blu2i Module  
complies with the appropriate essential requirements of the Article 3 of  
the R&TTE and the other relevant provisions, when used for its intended  
purpose.

Health and Safety requirements contained in Article 3 (1) a)

EN 60 950: 1992 Safety of information technology equipment +  
Amendment A1:1993, Amendment A2:1993, Amendment A3:1995,  
Amendment A4:1997, Amendment A11:1997

EN 50371: Generic standard to demonstrate the compliance of low-  
power electronic and electrical apparatus with the basic restrictions  
related to human exposure to electromagnetic fields (10 MHz - 300 GHz)  
– General public

Protection requirements with respect to electromagnetic compatibility  
Art.3 (1) b)

EN 301489-17 V1.1.1 (09-2000), Electromagnetic Compatibility and  
radio spectrum Matters (ERM); Electro Magnetic Compatibility (EMC)  
standard for radio equipment and services; Part 17: Specific conditions  
for wideband data HiperLAN equipment

Means of the efficient use of the radio frequency spectrum

EN 300328-2 V1.2.1 (11-2001), Radio Equipment and Systems (RES);  
Wideband transmission systems; Technical characteristics and test  
conditions for data transmission equipment operating in the 2,4 GHz  
ISM band and using spread spectrum modulation techniques. Part 2:  
Harmonized EN covering essential requirements under article 3(2) of the  
R&TTE directive.

Ezurio Ltd

tel: +44 (0)20 8938 1000

Unit 2, 126 Colindale Avenue, Colindale

fax: +44 (0)20 8905 8608

Registered in England

London NW9 5HD, United Kingdom

www.ezurio.com

No. 5178293

## 12.4.2 FCC and Industry Canada Statements

This device complies with part 15 of the FCC Rules. Operation is subject to the following two conditions: (1) This device may not cause harmful interference, and (2) this device must accept any interference received, including interference that may cause undesired operation.

Changes or modifications not expressly approved by the party responsible for compliance could void the user's authority to operate the equipment.

## 13. Environmental

### 13.1 Operating temperatures

Parameter	Min	Typ	Max	Unit
Operating temp (standard product)	-40	25	+85	°C

### 13.2 Storage temperature

Parameter	Min	Max	Unit
Storage temp	-40	+125	°C

### 13.3 Reliability

Parameter	Test	Comment
Thermal Shock	200 cycles -40°C /+85°C 30 min	1 cycle/hour
Vibration	Continuous operation at 60 Hz, 2mm stroke	15g max sine wave, 12 hours
Shock	50G 11ms Half Sine Wave	6 axis x 3 cycles each axis
Moisture Resistance		
High Temp Storage	85°C, 360 hours	
Low Temp Storage	-40°C, 240 hours	
High Temp/Humidity Operation	60°C, 90%RH, 360 hours	
Thermal shock	-40 to 60°C in 30min	200 cycles with continuous operation
Electro Static Discharge	EN55024:1998 & IEC61000-4-3	
Drop Test	75cm to concrete, 3 axis x 2 cycles per corner	

# 14. Physical Dimensions

## 14.1 Mechanical Dimensions

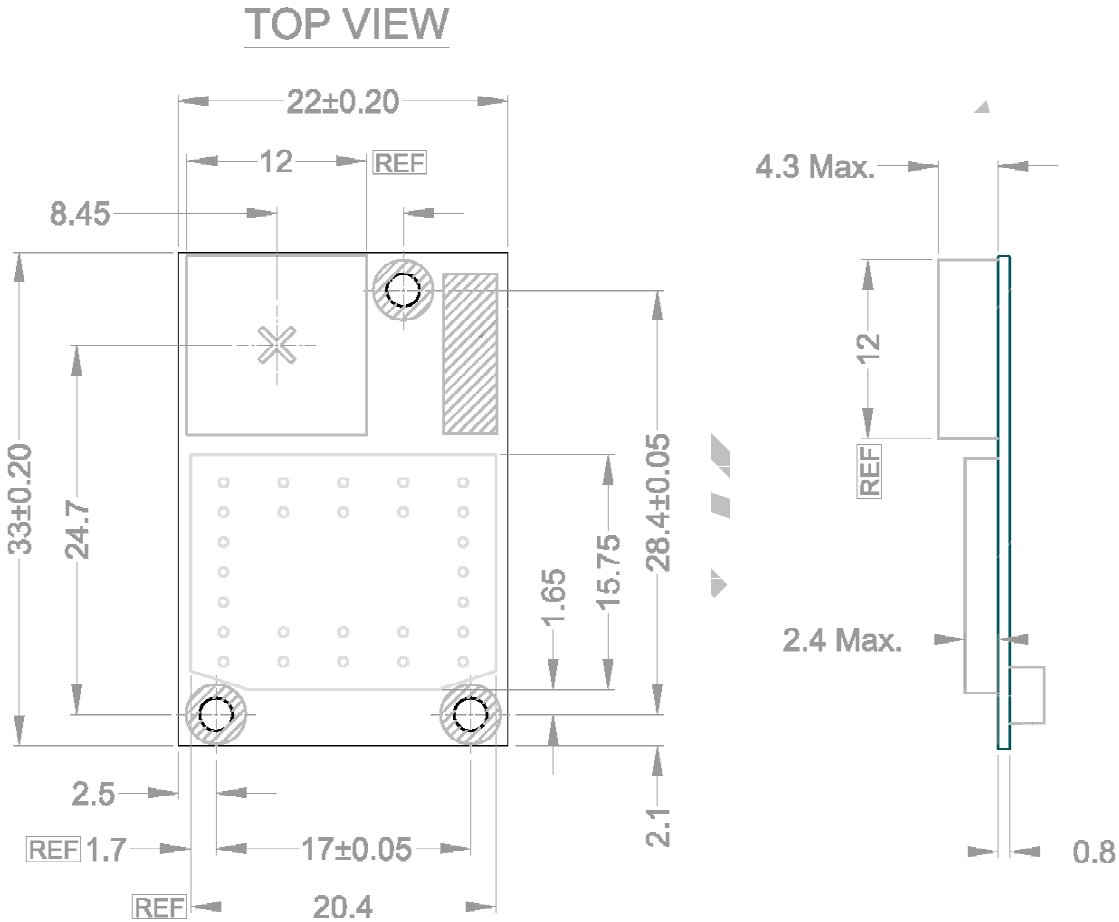

All dimensions in mm.

## 14.2 Labelling

The label contains the Part number and the unique Bluetooth address of the module.

## 14.3 Ordering Information

The BISM2 is available with different variants of production firmware. Ordering information is provided below:

Part Number	Description	Firmware Version
TRBLU23-00200	BISM2 with integrated ceramic antenna and standard AT firmware	Version 4.9.0
TRBLU23-002MP	BISM2 with integrated ceramic antenna and standard Multipoint firmware	Version 1.4.5.0
TRBLU23-002HC	BISM2 with integrated ceramic antenna and standard HCI firmware	Version 4.9.0
TRBLU23-00300	BISM2 with SMA jack and standard AT firmware	Version 4.9.0
TRBLU23-003MP	BISM2 with SMA jack and standard Multipoint firmware	Version 1.4.5.0
TRBLU23-003HC	BISM2 with SMA jack and standard HCI firmware	Version 4.9.0

## 15. Related Documents

- Blu2i AT Reference Manual
- Blu2i Multipoint Firmware Reference Manual
- BISM Bluetooth Serial Module Quick Start Guide
- BISM Bluetooth Module Application Guide
- BISM Developer's Kit User Guide
- Bluetooth Core 2.0 Specification – [www.bluetooth.org](http://www.bluetooth.org)

## 16. Datasheet Revision History

Version	Date	Changes
0.91	10 <sup>th</sup> March 2005	Initial Draft for customer release.

# 17. Disclaimers

EZURIO'S BLUETOOTH PRODUCTS ARE NOT AUTHORISED FOR USE AS CRITICAL COMPONENTS IN LIFE SUPPORT DEVICES OR SYSTEMS WITHOUT THE EXPRESS WRITTEN APPROVAL OF THE MANAGING DIRECTOR OF EZURIO LTD.

The definitions used herein are:

- a) Life support devices or systems are devices which (1) are intended for surgical implant into the body, or (2) support or sustain life and whose failure to perform when properly used in accordance with the instructions for use provided in the labelling can reasonably be expected to result in a significant injury to the user.
- b) A critical component is any component of a life support device or system whose failure to perform can be reasonably expected to cause the failure of the life support device or system, or to affect its safety or effectiveness.

Ezurio does not assume responsibility for use of any of the circuitry described, no circuit patent licenses are implied and Ezurio reserves the right at any time to change without notice said circuitry and specifications.

## 17.1 Data Sheet Status

This data sheet contains data from the Preliminary specification. Supplementary data will be published at a later date. Ezurio Ltd reserve the right to change the specification without notice in order to improve the design and supply the best possible product.

Please check with Ezurio Ltd for the most recent data before initiating or completing a design.

## 17.2 Warranty

Ezurio warrants that its products shall conform to Ezurio's published specifications and remain free from defects in materials and workmanship under normal, proper and intended use for a period of two (2) years from date of purchase, provided that proof of purchase be furnished with any returned equipment.

If during the warranty period any component part of the equipment becomes defective by reason of material or workmanship, and Ezurio is immediately notified of such defect, Ezurio shall at its option supply a replacement part or request return of equipment, freight prepaid, to its designated facility for repair. In the event no trouble is found on products returned for repair, Ezurio reserves the right to charge the customer its standard published repair charge.

This warranty shall not apply to any products that have been subject to misuse, bending, twisting, neglect, alteration, improper installation, testing or unauthorized repair performed by anyone other than a Ezurio designated repair facility. Any non-warranty repairs or maintenance shall be at Ezurio's standard rates in effect at the time.

This warranty is in lieu of all other warranties, whether expressed, implied, or statutory, including but not limited to, implied warranties or merchantability and fitness for a particular purpose. In no event shall Ezurio be liable, whether in contract, in part, or on any other basis, for any damage sustained by its customers or any other person arising from or related to loss of use, failure or interruption in the operation of any products, or delay in maintenance, or for incidental, consequential, in direct, or special damages or liabilities, or for loss of revenue, loss of business, or other financial loss arising out of or in connection with the sale, lease, maintenance, use, performance, failure, or interruption of these products.