Section 5

Test Report

TABLE OF CONTENTS

5.1	Test Strategy	2
5.2	Test Equipment List	4
5.3	RF Power Output	5
5.3.1.	Conducted RF Power Output Test Results	7
5.3.2.	Conducted RF Power Calculations for 100 kHz PSD	9
5.3.3.	Conducted RF Power Output Plots	10
5.3.4.	100 kHz Power Spectral Density Plots.....	21
5.4	Modulation Characteristics	25
5.4.1.	Modulation Characteristics Test Results Summary	27
5.4.2.	Modulation Characteristics Data Plots	36
5.5	Occupied and Emission Bandwidth	37
5.5.1.	Occupied and Emission Bandwidth Test Results Summary	38
5.5.2.	Occupied and Emission Bandwidth Spectrum Analyzer Plots	38
5.6	Transmitter Spurious Emissions	42
5.6.1.	Transmitter Spurious Emissions Plots.....	43
5.6.2.	Second Harmonic Emissions Plots	52
5.6.3.	Harmonic 3 Emissions Plots.....	55
5.7	Field Strength of Spurious Radiation	58
5.8	Frequency Stability Test	59
5.8.1.	Temperature Variation Test Results.....	61
5.8.2.	Temperature Variation Spectrum Analyzer Plots	62
5.8.3.	Supply Voltage Variation Test Results	67
5.8.4.	Supply Voltage Variation Spectrum Analyzer Plots	68

5.1 Test Strategy

The Motorola RDMi25100 is a dual mode residential subscriber unit which operates in either the proprietary Expedience mode or the WiMax mode. The operating mode is determined by the type of base station equipment with which this device would establish a communications exchange. This test report (Section 5B) covers the WiMax mode, and Section 5A covers the Expedience mode.

Verification of the performance of the Motorola, Inc., RDMi-25100 IEEE 802.16e WiMax transmitter was accomplished by implementation of the procedures contained within TIA/EIA-603 and FCC requirements. Performance results contained within this Test Report and Appendix documents represent modes that are considered to be representative of a worst case operating condition.

Verification of product performance is presented for three frequencies across the RF bandwidth, two channel bandwidths, seven modulation configurations, eight transmit dutycycles, and 17 or 35 subchannels that are available within IEEE 802.16e standard – resulting in a possible test combination exceeding 2 trillion distinct measurements. To reduce the test burden, a series of measurements were performed to observe the variations in the measured. Based on the consistency of these measurements, the information presented in this test report is believed to represent a worst case scenario. The Motorola, Inc., RDMi-25100 product has been tested with equipment that is generally available in the open market. A primary requirement for the measurement of the RDMi-25100 product is that the spectrum analyzer contain a time gating function to facilitate the accurate measurement of the channel power and emissions mask. The time gating function is configured to only allow the spectrum analyzer to sweep when the transmitter is active. Measurements performed on the RDMi-25100 product were performed with an Agilent E4440A spectrum analyzer with the time gating capability.

The WiMax system protocol utilizes the ability to transmit on sub-channel carriers ranging from 1 to 17 (all) on each 5 MHz transmission burst and 1 to 35 (all) on each 10 MHz transmission burst. To facilitate the product development, a test mode configuration was developed. The test mode allows for the selection of channel frequency, modulation bandwidth, and modulation type (4-QAM, 16-QAM, 64-QAM, + various coding combinations...). Within the test mode, a pseudo random bit sequence is used to generate the transmitted data.

The Motorola, Inc. WiMax system is based on the IEEE 802.16e protocol. The Motorola, Inc. WiMax system protocol makes use of Time Division Duplex (TDD) operation as allowed by the FCC Report and Order and Further Notice of Proposed Rulemaking, FCC 04-135, at 134. Within the BRS and EBS frequency spectrum, channels are allocated in 5.5 MHz and 6.0 MHz single frequency blocks. FCC rules contained in 27.1220 allows for the splitting and combining of channel spectrum, when done jointly with other licensees that would accommodate the 10 MHz emission from a WiMax transmission anywhere within the BRS/EBS spectrum. Additional information is contained in the Technical Description document.

The Motorola, Inc., RDMi-25100 product does not contain “smart” antenna technology. The integral antenna contained within the RDMi-25100 product is a four-element patch array antenna. This antenna has a fixed gain and radiation pattern. Plots of the antenna performance are shown in the Section 13 Technical Description document.

5.2 Test Equipment List

Test Equipment	Description
DUT	Motorola Residential Dual Mode Subscriber Unit Model No. RDMi-25100 Board No. 0092-0300-7180070
Spectrum Analyzer	Agilent E4440A S/N: MY44022791 Calibrated: 05/21/2007 Calibration due: 05/21/2009
Attenuators (All applicable tests except harmonic frequencies)	40 dB, 10W Attenuator MCE/Weinshel Model 23-40-34, S/N. BT 1498 10 dB, 10W Attenuator MCE/Weinshel Model 23-10-34, S/N. BT 3857 Calibrated by user
Filter/Attenuator Assembly (Harmonic frequency test only)	High Pass Filter 4-18 GHz, P/N H04G18G2, S/N 89099 Microwave Circuits 20 dB, 10W Attenuator, MCE/Weinshel Model 23-20-34, S/N BP4391 Calibrated by user
Laptop Computer (NN1303)	Dell Precision M65 S/N: CRFK 381 Calibration not required
Ethernet Switch	D-Link Model: DSS-5+ 5-port 10/100Mbps S/N: DT8615B009993 Calibration not required
RSU Power Supply	OTE-17-13 13V, 1.3A Rev. Level 3
AC Power Source (Frequency Stability Test Only)	Instek APS-9501 S/N: EF844094 Calibrated with voltmeter listed below.
Digital Voltmeter	HP 34401A S/N: MY45001201 Calibrated: 5-4-2007 / Calibration due: 5-4-2009
Temperature Chamber	Test Equity Model: 1007H S/N: 61134 Temperature verified with thermocouple listed below
Temperature Sensor	Fluke 89 IV True RMS Multimeter S/N 87180024 with K-Type Thermocouple

5.3 RF Power Output

FCC Rules: 2.1046, 27.4, 27.50(h)(2), 27.50(h)(4) 27.50(i)

FCC Requirement: User stations. All user stations are limited to 2.0 watts transmitter output power. (5 MHz or 10 MHz channel BW)

$$\begin{aligned} \text{Power Spectral Density (PSD)} &= [\text{power} / 6 \text{ MHz}] \times 100 \text{ kHz} \\ \text{PSD (watts)} &= (2 / 6,000,000) \times 100,000 \\ &= 0.0333 \text{ watts per } 100 \text{ kHz.} \end{aligned}$$

Standard: TIA-603-C
TIA Standard, Land Mobile FM or PM Communications Equipment, Measurement and Performance Standards

Test Procedure: The peak conducted RF output power is measured over an interval of continuous transmission using a spectrum analyzer that has been calibrated in terms of rms-equivalent voltage. The peak power was recorded by utilizing the power measurement function within the spectrum analyzer. The power measurement function of this spectrum analyzer, when using a 100 kHz resolution bandwidth, has been compared against measurements performed with a power meter. The power measurements obtained from the spectrum analyzer and the power meter comparison produced the same value. As such, no additional correction factors were applied to the measured data.

The RF output of the transmitter was measured at J501 which is the RF output of the main board. The antenna board is soldered directly to this connector. This signal is applied to the spectrum analyzer through a coaxial cable and 40 dB attenuator. The spectrum analyzer is time gated by the PA_ON signal at WO505 on the main board so that only RF transmission bursts are captured.

The transmitter is enabled in the test mode and set to the minimum and maximum power level with the host computer. The RF loss of the attenuator and coax was measured and is included in the spectrum analyzer offset level for the maximum and minimum RF power measurements.

Measurements are performed at frequencies at the low, mid, and high points of the band and for each of the modulation formats available (QPSK-1/2, QPSK-3/4 and 16 QAM 1/2, 16 QAM 3/4, 64 QAM 1/2, 64 QAM 2/3, and 64 QAM 3/4). In addition, measurements were taken with 1 – 8 time slots selected, and at both channel bandwidths (5.0 and 10 MHz).

Measurements at a center frequency of 2593 MHz were performed to exhibit compliance to the 27.50(h)(4) requirement, when less than all subchannels are enabled, by adjusting the resolution bandwidth of the spectrum analyzer to 10 kHz. The span was set to 5 MHz for a 5 MHz emission and 10 MHz for a 10 MHz emission. The sweep number of points was set to 501 for a 5 MHz emission and 1001 for a 10 MHz emission. The data points were then extracted from the spectrum analyzer and placed into an Excel spreadsheet. The data points, each representing 10 kHz of spectrum, were converted from their dBm value to the equivalent power in watts for a 50 ohm system. Starting at the first extracted data point, each ten consecutive power values were summed together to achieve the total power in a 100 kHz band. These values were then compared to the emission limit defined in the 27.50(h)(4) requirement.

Test Conditions: **Test Frequencies:** 2499, 2593, 2687 MHz (5.0 and 10 MHz bandwidth)
 Temperature: 22°C
 Supply Voltage: 120 VAC / 60 Hz nominal to DUT power supply

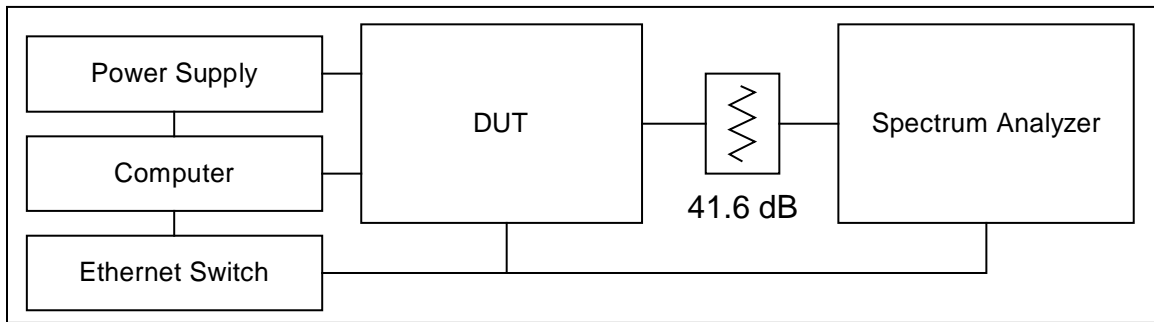

Conducted RF Power Test Setup

5.3.1. Conducted RF Power Output Test Results

Maximum Power – 5.0 MHz Bandwidth, all subcarriers

RDMi-25100 Carrier Power (5.0 MHz Bandwidth Channels)									
Channel (MHz)	Modulation	Maximum Carrier Power (dBm)							
		Time Slots: 1	Time Slots: 2	Time Slots: 3	Time Slots: 4	Time Slots: 5	Time Slots: 6	Time Slots: 7	Time Slots: 8
2499	QPSK 1/2	28.00	28.03	28.01	27.80	27.71	27.61	27.64	27.49
	QPSK 3/4	28.02	28.08	27.96	27.90	27.79	27.75	27.63	27.47
	16 QAM 1/2	28.02	27.97	27.98	27.88	27.77	27.73	27.59	27.58
	16 QAM 3/4	28.02	28.01	28.00	27.92	27.72	27.65	27.68	27.48
	64 QAM 1/2	27.95	27.98	27.97	27.80	27.81	27.69	27.52	27.51
	64 QAM 2/3	28.02	28.01	27.90	27.86	27.68	27.71	27.54	27.49
2593	64 QAM 3/4	27.99	28.02	27.96	27.84	27.67	27.65	27.53	27.52
	QPSK 1/2	26.94	26.91	26.85	26.76	26.73	26.69	26.60	26.56
	QPSK 3/4	26.95	26.97	26.88	26.80	26.75	26.68	26.59	26.51
	16 QAM 1/2	26.93	26.92	26.85	26.81	26.78	26.56	26.59	26.56
	16 QAM 3/4	26.92	26.90	26.91	26.84	26.81	26.63	26.58	26.39
	64 QAM 1/2	26.85	26.87	26.87	26.85	26.73	26.62	26.47	26.47
2687	64 QAM 2/3	26.94	26.94	26.87	26.78	26.77	26.63	26.47	26.51
	64 QAM 3/4	26.89	26.86	26.82	26.79	26.70	26.55	26.40	26.48
	QPSK 1/2	27.75	27.76	27.63	27.58	27.50	27.43	27.40	27.38
	QPSK 3/4	27.71	27.75	27.66	27.60	27.55	27.44	27.36	27.33
	16 QAM 1/2	27.73	27.63	27.61	27.56	27.50	27.42	27.30	27.27
	16 QAM 3/4	27.71	27.70	27.66	27.62	27.49	27.46	27.40	27.25
2687	64 QAM 1/2	27.68	27.73	27.55	27.58	27.51	27.38	27.27	27.22
	64 QAM 2/3	27.66	27.58	27.62	27.55	27.43	27.38	27.28	27.24
	64 QAM 3/4	27.73	27.65	27.68	27.54	27.44	27.37	27.11	27.27

Maximum Power – 10 MHz Bandwidth, all subcarriers

RDMi-25100 Carrier Power (10.0 MHz Bandwidth Channels)									
Channel (MHz)	Modulation	Maximum Carrier Power (dBm)							
		Time Slots: 1	Time Slots: 2	Time Slots: 3	Time Slots: 4	Time Slots: 5	Time Slots: 6	Time Slots: 7	Time Slots: 8
2499	QPSK 1/2	27.16	27.17	27.11	27.05	26.63	26.87	26.68	26.57
	QPSK 3/4	26.97	26.94	27.13	27.02	26.66	26.97	26.79	26.67
	16 QAM 1/2	26.95	26.90	27.14	27.02	26.63	26.92	26.77	26.69
	16 QAM 3/4	26.97	26.96	27.09	27.04	26.62	26.95	26.66	26.61
	64 QAM 1/2	27.16	26.89	27.05	27.04	26.59	26.87	26.63	26.58
	64 QAM 2/3	27.09	27.11	27.07	26.95	26.57	26.85	26.62	26.55
2593	64 QAM 3/4	27.15	27.16	27.06	26.96	26.59	26.76	26.67	26.61
	QPSK 1/2	26.78	26.74	26.69	26.90	26.48	26.70	26.60	26.50
	QPSK 3/4	26.79	26.80	26.72	26.61	26.52	26.76	26.57	26.52
	16 QAM 1/2	26.79	26.77	26.72	26.60	26.45	26.75	26.63	26.49
	16 QAM 3/4	26.76	26.77	26.72	26.52	26.50	26.78	26.33	26.45
	64 QAM 1/2	26.74	26.74	26.61	26.55	26.39	26.32	26.63	26.49
2687	64 QAM 2/3	26.73	26.66	26.65	26.55	26.38	26.77	26.51	26.54
	64 QAM 3/4	26.74	26.70	26.88	26.50	26.46	26.79	26.55	26.47
	QPSK 1/2	26.76	26.76	26.70	26.68	26.69	26.52	26.38	26.27
	QPSK 3/4	26.74	26.76	26.70	26.63	26.69	26.49	26.42	26.30
	16 QAM 1/2	26.72	26.75	26.73	26.62	26.71	26.48	26.42	26.16
	16 QAM 3/4	26.75	26.73	26.71	26.62	26.71	26.49	26.31	26.22
2687	64 QAM 1/2	26.73	26.69	26.67	26.60	26.63	26.37	26.37	26.22
	64 QAM 2/3	26.70	26.65	26.64	26.61	26.60	26.32	26.25	26.20
	64 QAM 3/4	26.73	26.73	26.67	26.58	26.62	26.40	26.29	26.19

Minimum Power, all subcarriers

RDMi-25100 Carrier Power (5.0 MHz Bandwidth Channels)				
Channel (MHz)	Modulation	Minimum Carrier Power (dBm)		
			Time Slots: 8	
2499	16 QAM 3/4		-18.56	
2593	16 QAM 3/4		-19.73	
2687	16 QAM 3/4		-21.84	

RDMi-25100 Carrier Power (10.0 MHz Bandwidth Channels)				
Channel (MHz)	Modulation	Minimum Carrier Power (dBm)		
			Time Slots: 8	
2499	16 QAM 3/4		-18.51	
2593	16 QAM 3/4		-19.81	
2687	16 QAM 3/4		-21.73	

100 kHz Power Spectral Density, various subcarriers enabled

- Complies to the requirements of 27.50(h)(4).

5.3.2. Conducted RF Power Calculations for 100 kHz PSD

Data point level (dBm) = -47.64 dBm

Data point level (watts) = $0.001 \times 10^{(-47.64/10)} = 0.0000000172$

100 kHz bin 1 (watts) = summation (Trace points 1 thru 10)
 = 17+18+26+36+45+70+87+115+111
 = 680 nwatts

Trace Point	Freq (Hz)	Trace1 (dBm)	Trace1 (Watts)		
1	2590500000	-47.64	0.000000017		
2	2590510000	-47.39	0.000000018		
3	2590520000	-45.82	0.000000026		
4	2590530000	-44.48	0.000000036		
5	2590540000	-43.46	0.000000045		
6	2590550000	-41.56	0.000000070		
7	2590560000	-40.59	0.000000087		
8	2590570000	-39.38	0.000000115		
9	2590580000	-39.56	0.000000111	100 kHz bin	Power/100 kHz (W)
10	2590590000	-38.09	0.000000155	1	0.00000068
11	2590600000	-37.80	0.000000166	2	0.00000082
12	2590610000	-36.08	0.000000246	3	0.00000105

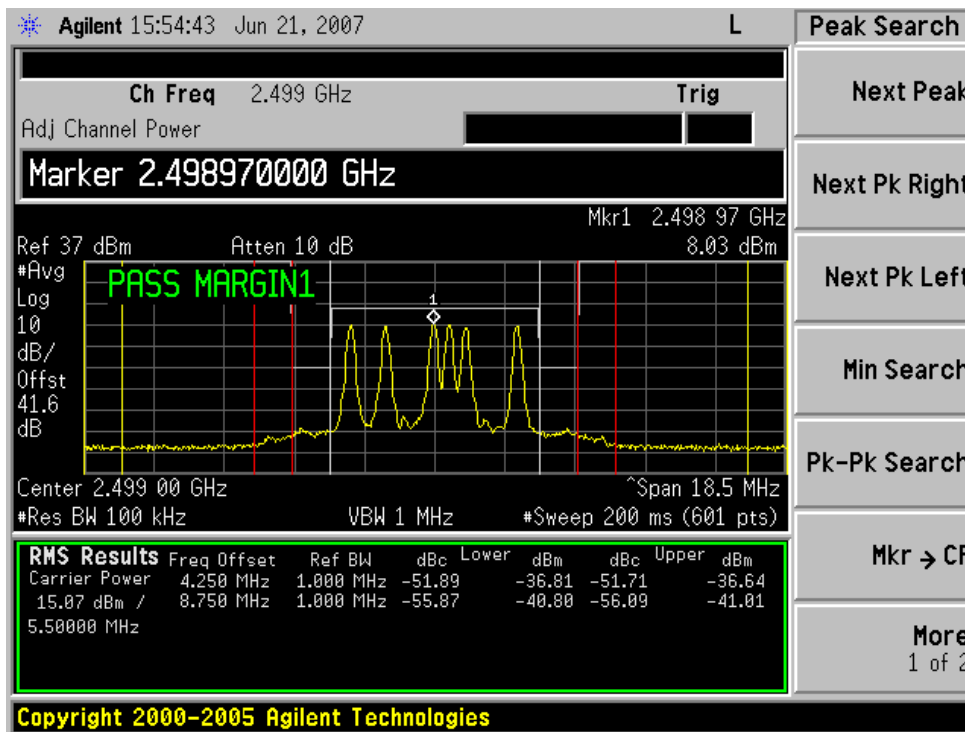

Single Subchannel Transmission Example

5.3.3. Conducted RF Power Output Plots

Spectrum analyzer plots for 2593 MHz, Time Slots = 1 (6.17% duty cycle), and all seven modulation types are displayed for 5.0 and 10 MHz bandwidth channels on the following pages. The conducted power level is indicated in the lower part of the screen under “Carrier Power”. For the minimum power level, all plots are displayed starting on page 18.

Additional plots are shown in Appendix B (“Conducted Power and Modulation Characteristics Plots”). The same plots are used for Modulation Characteristics (Section 5.4). Plots are then provided for each of those channel/ modulation configurations as follows:

2499 MHz, 5.0 MHz BW – 64 QAM 3/4
2593 MHz, 5.0 MHz BW – 64 QAM 3/4
2687 MHz, 5.0 MHz BW – QPSK 1/2
2499 MHz, 10 MHz BW – 64 QAM 2/3
2593 MHz, 10 MHz BW – 64 QAM 3/4
2687 MHz, 10 MHz BW – 16 QAM 3/4

Maximum Power Level Plots on the following pages:

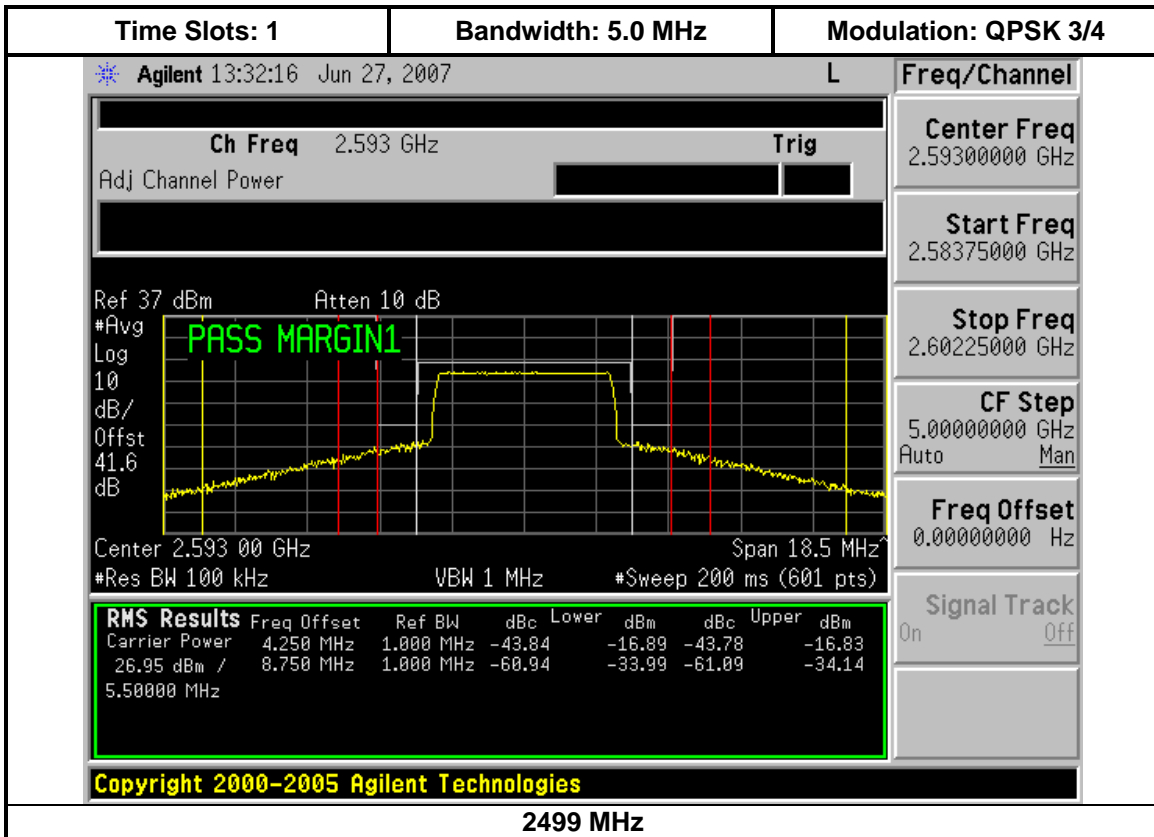
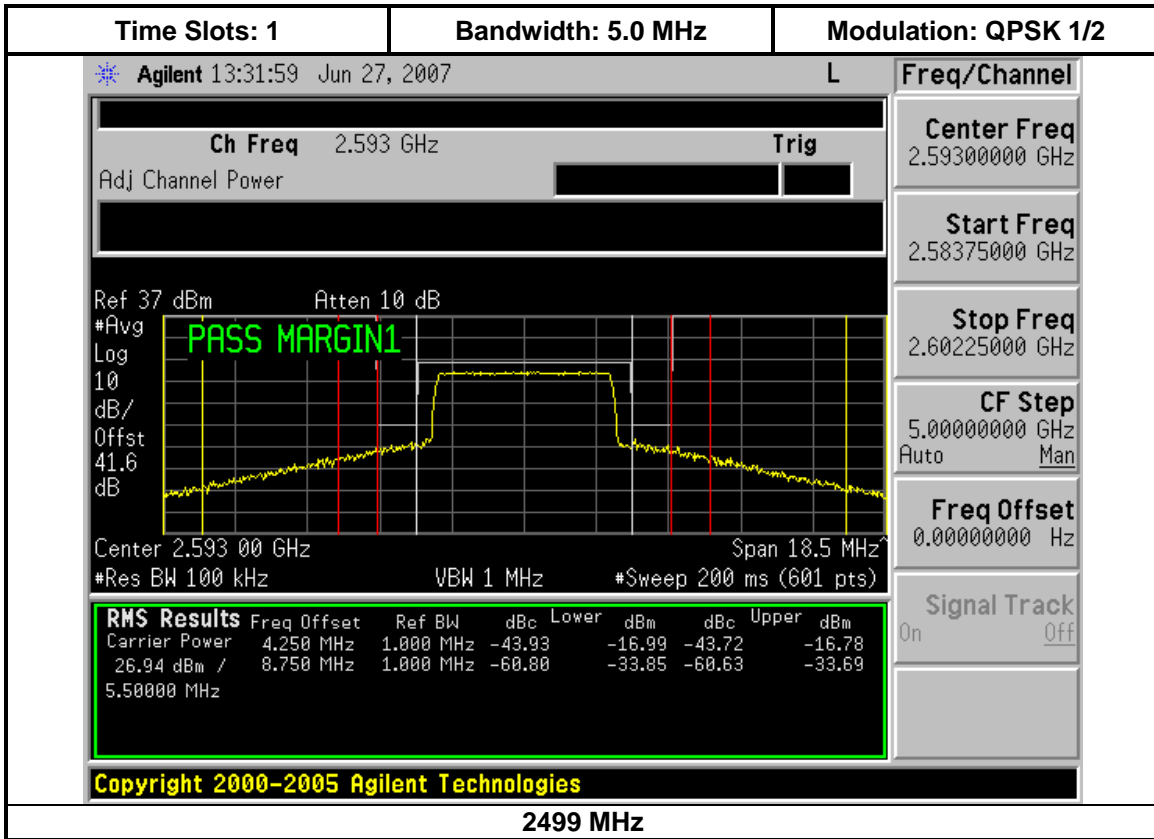

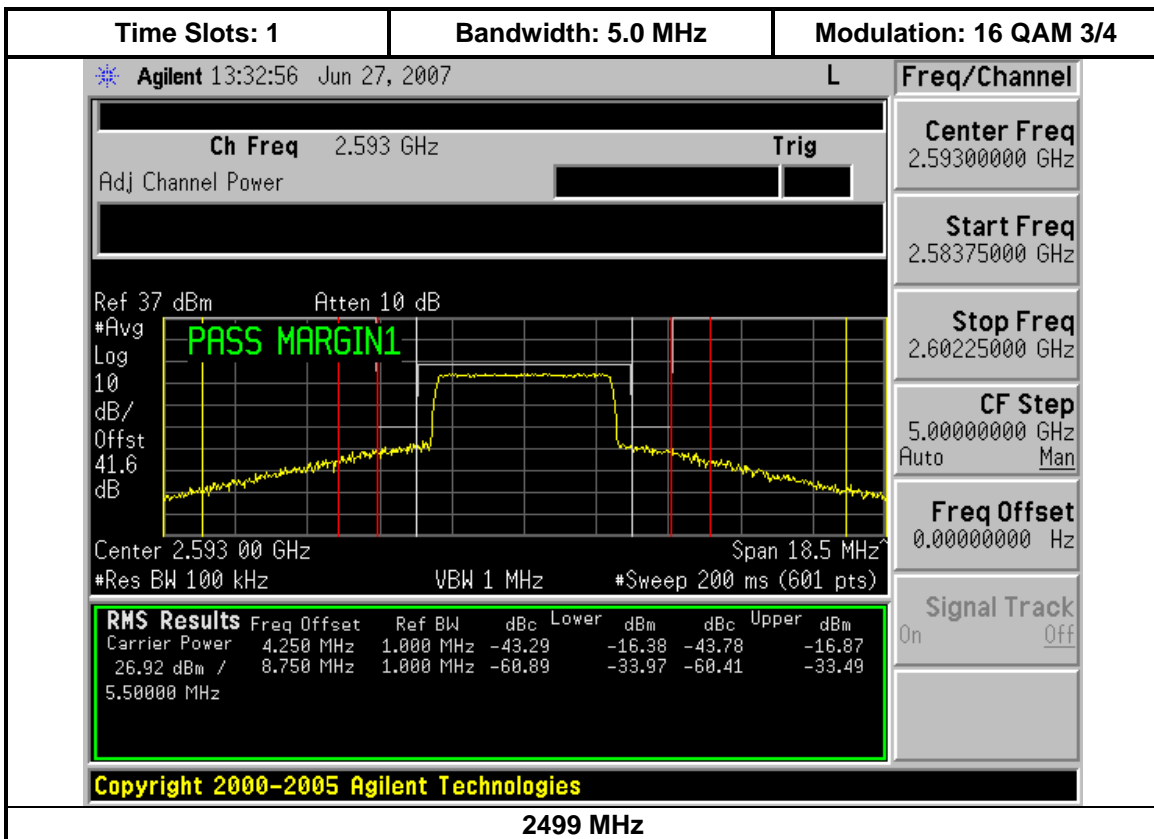
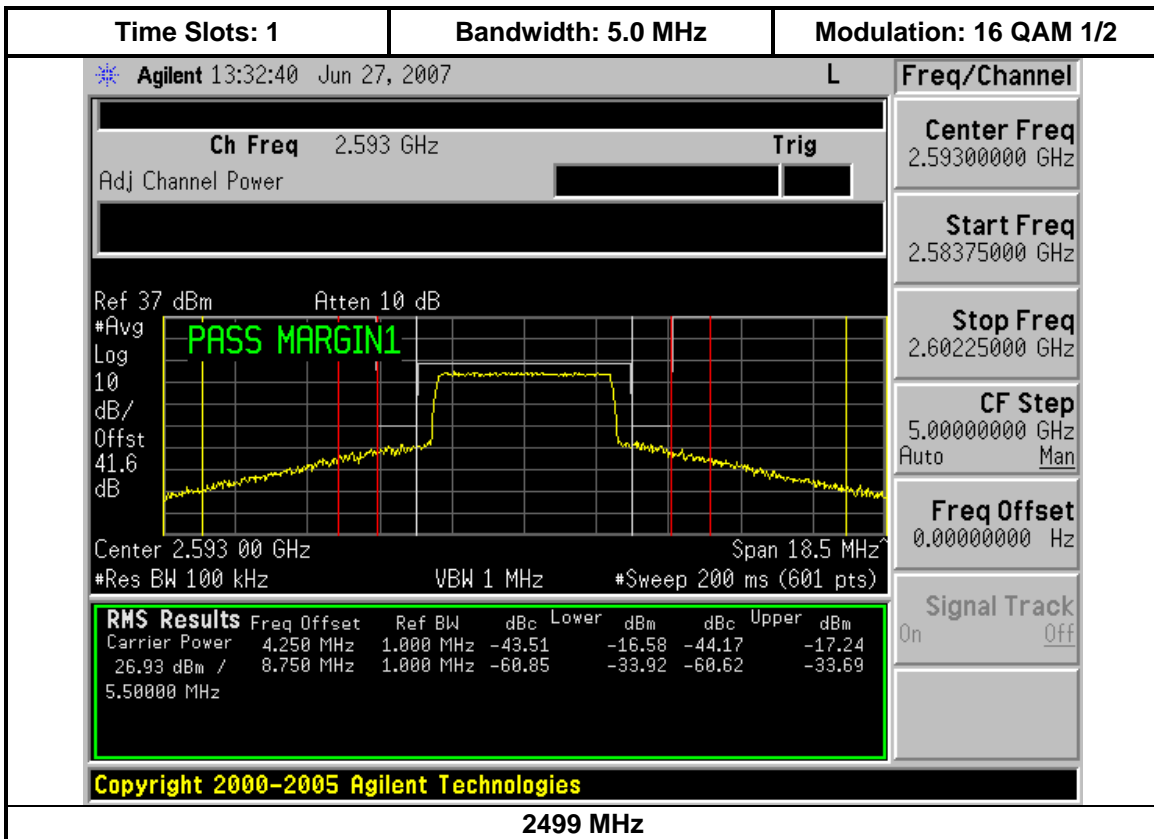

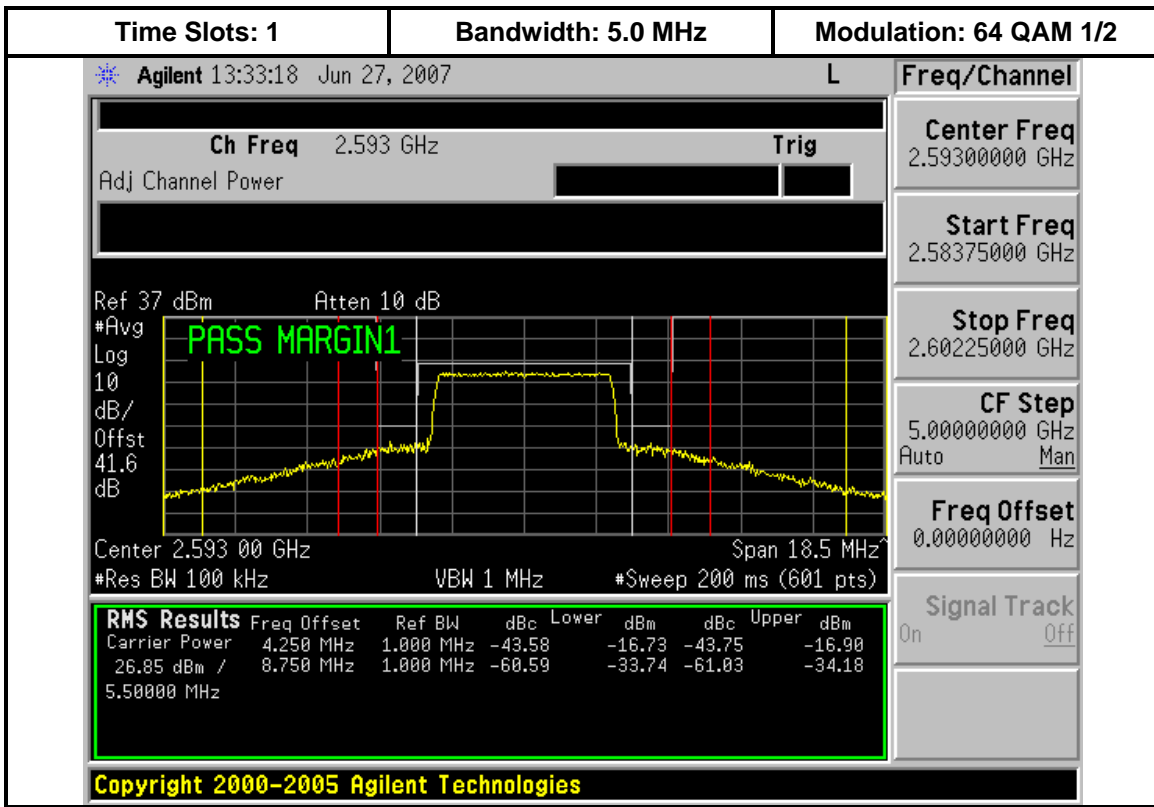

2499 MHz

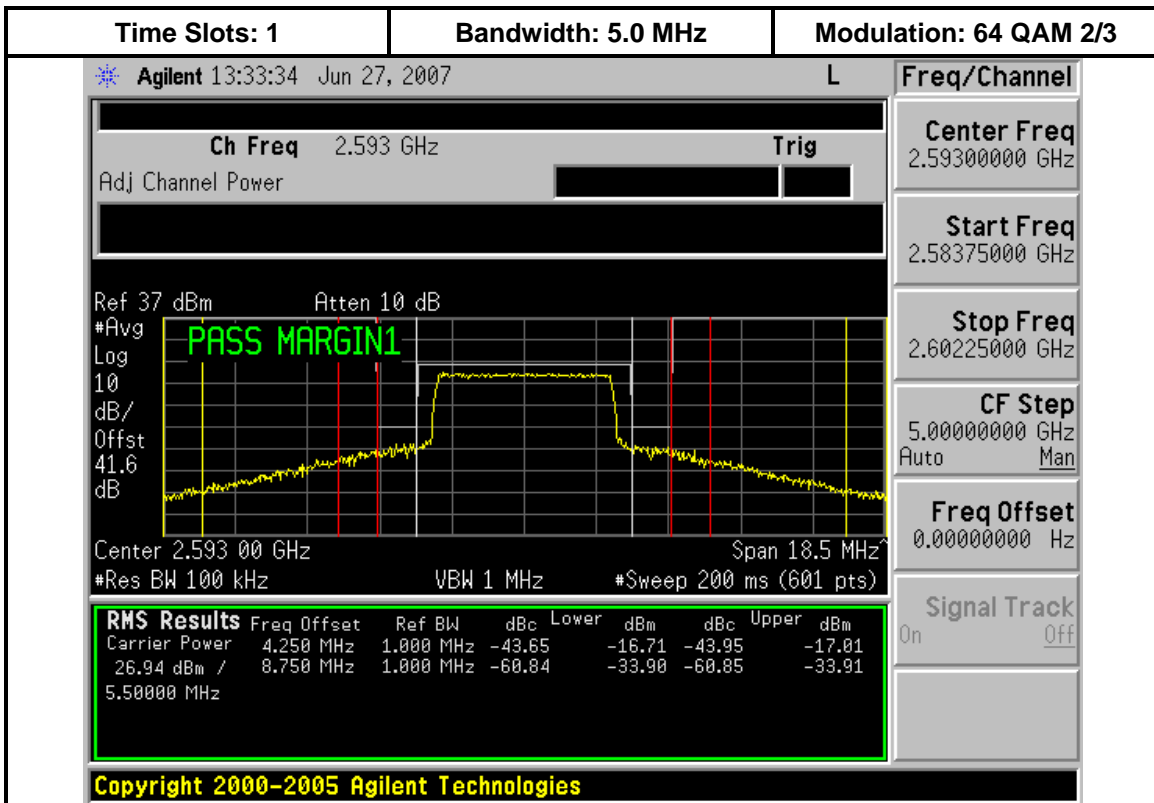

2499 MHz

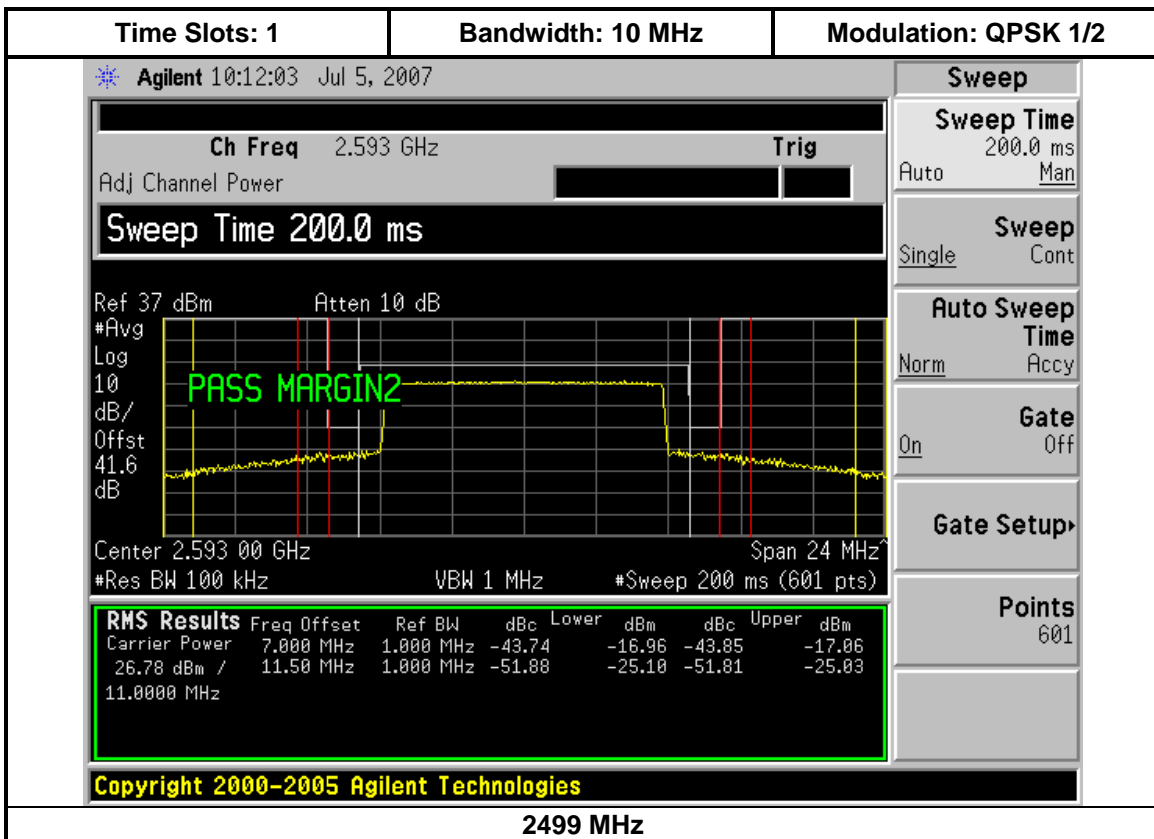
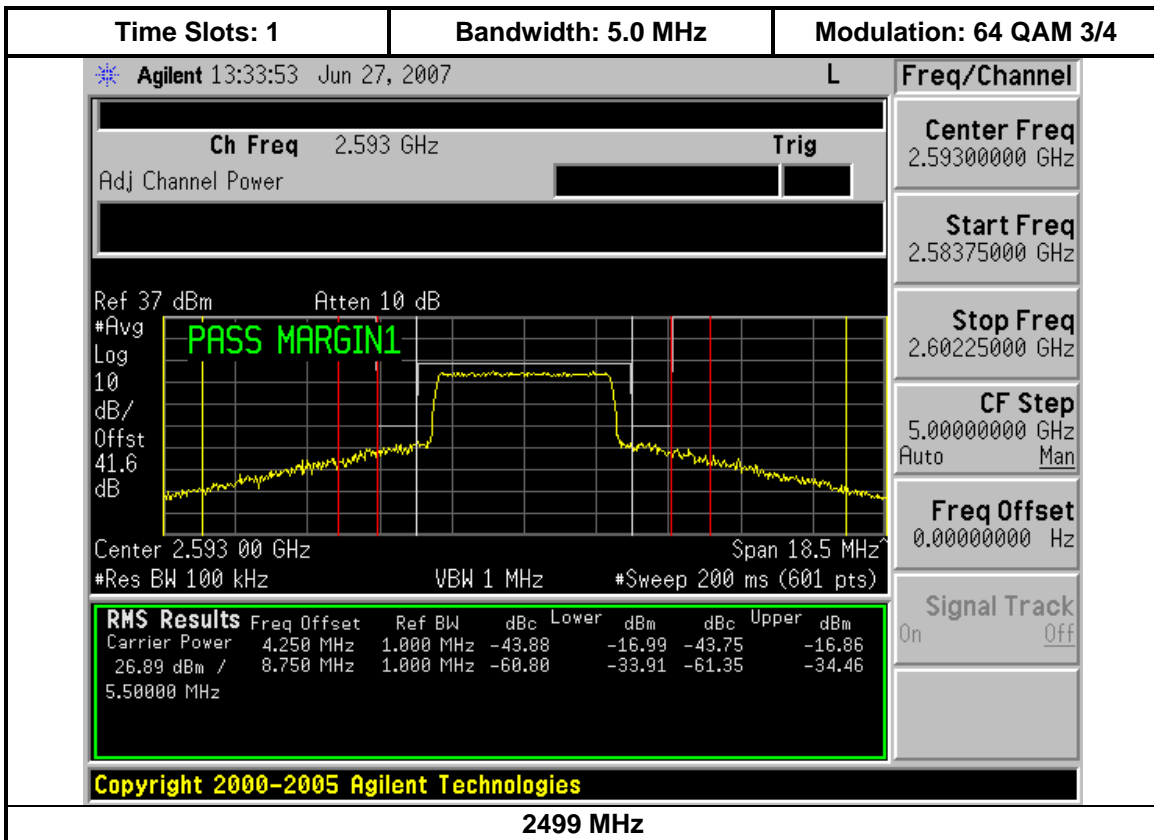

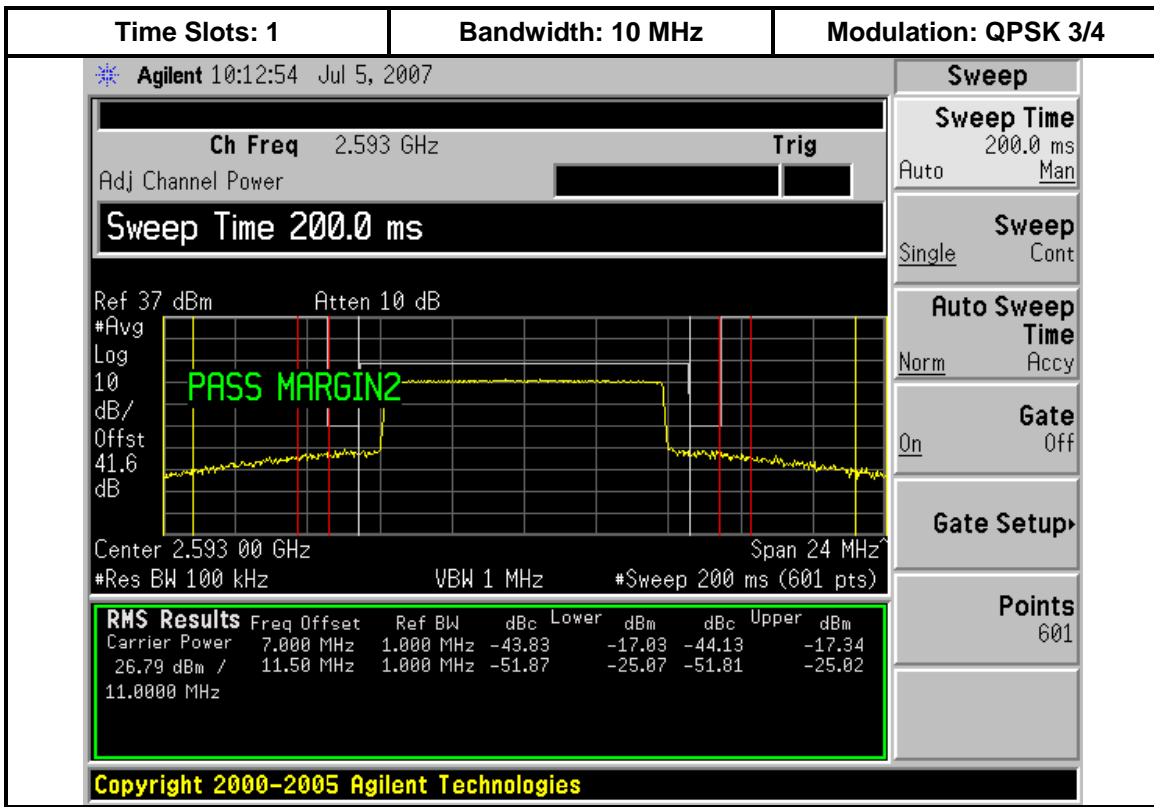

2499 MHz

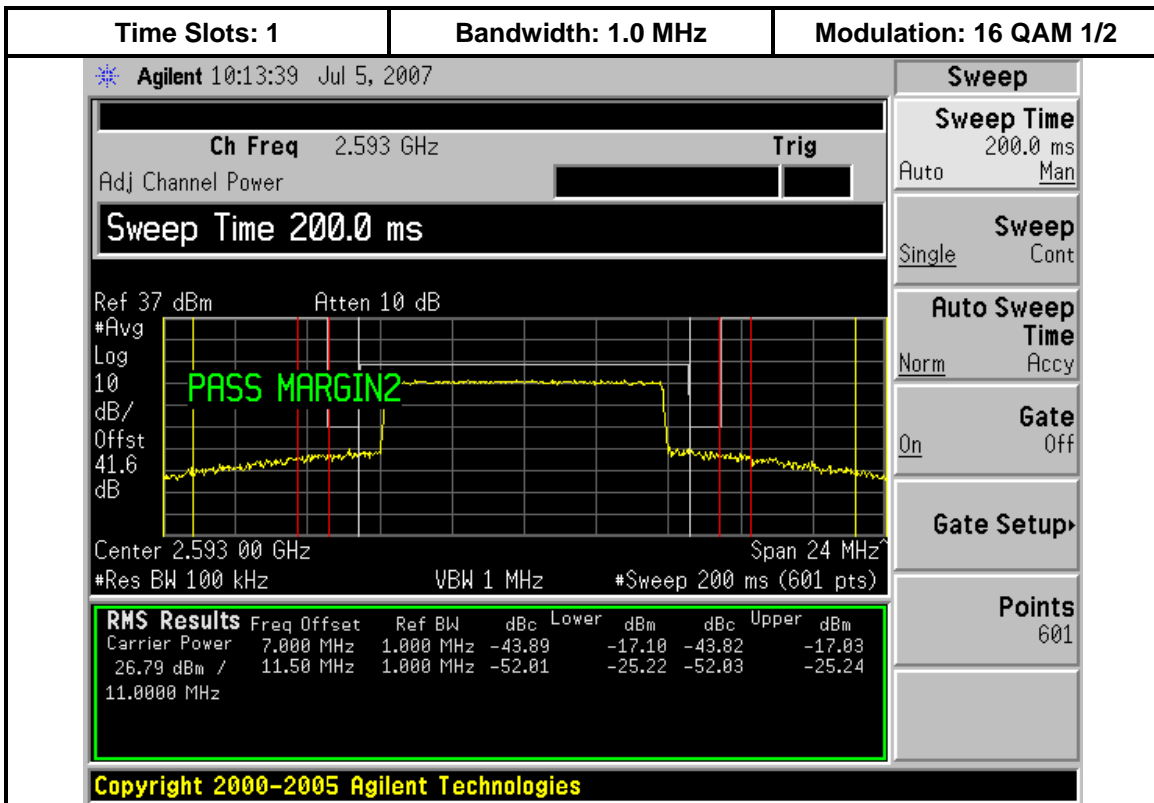

2499 MHz

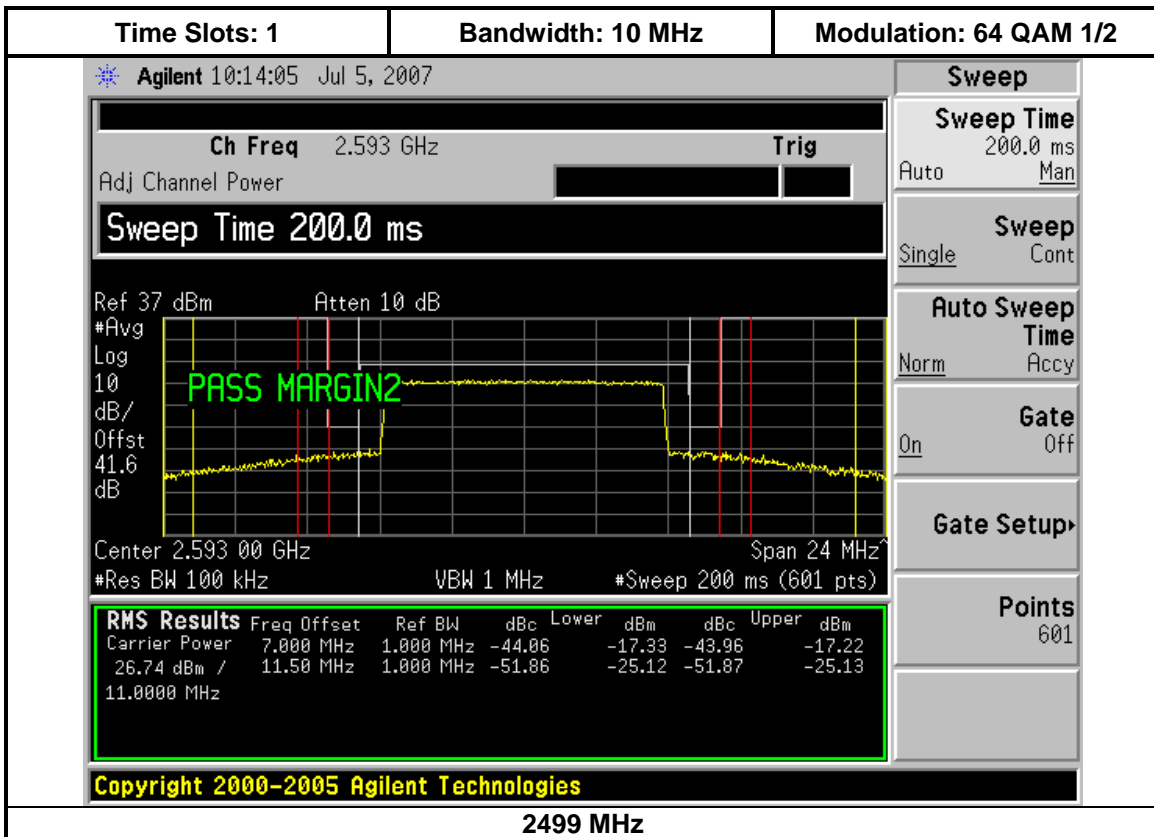
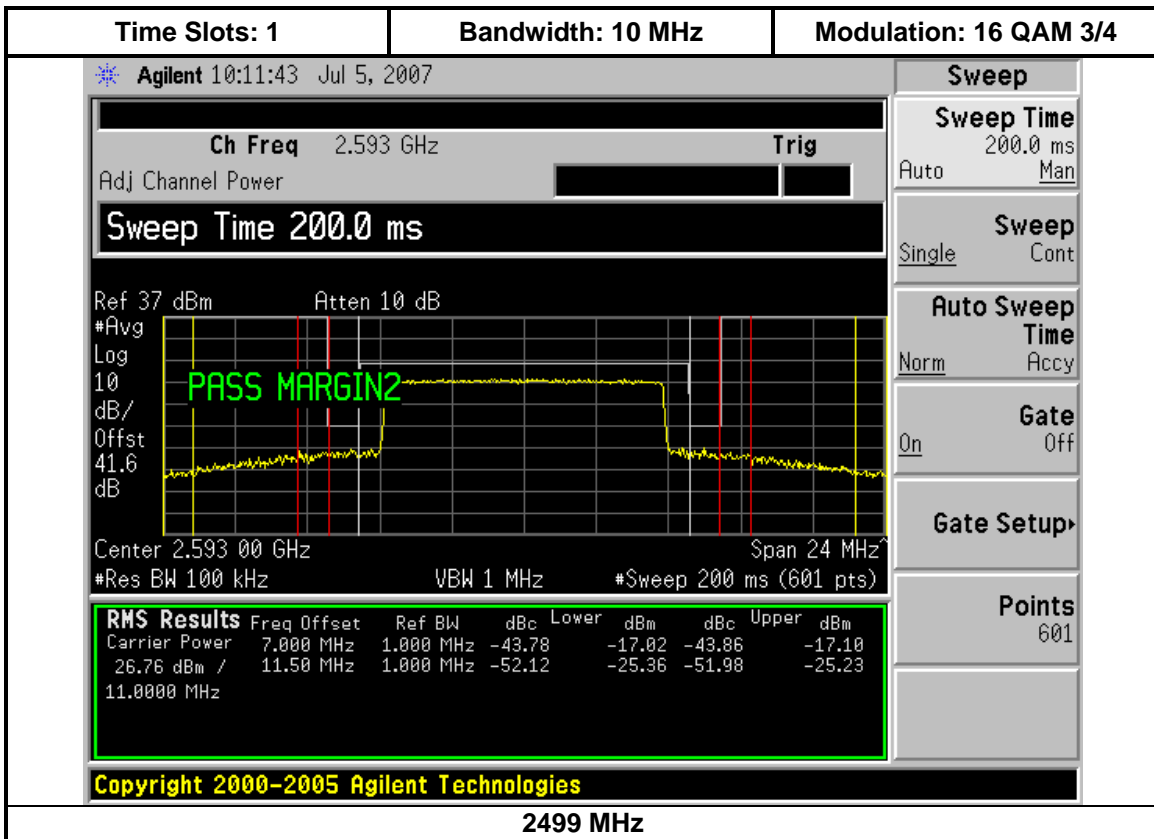

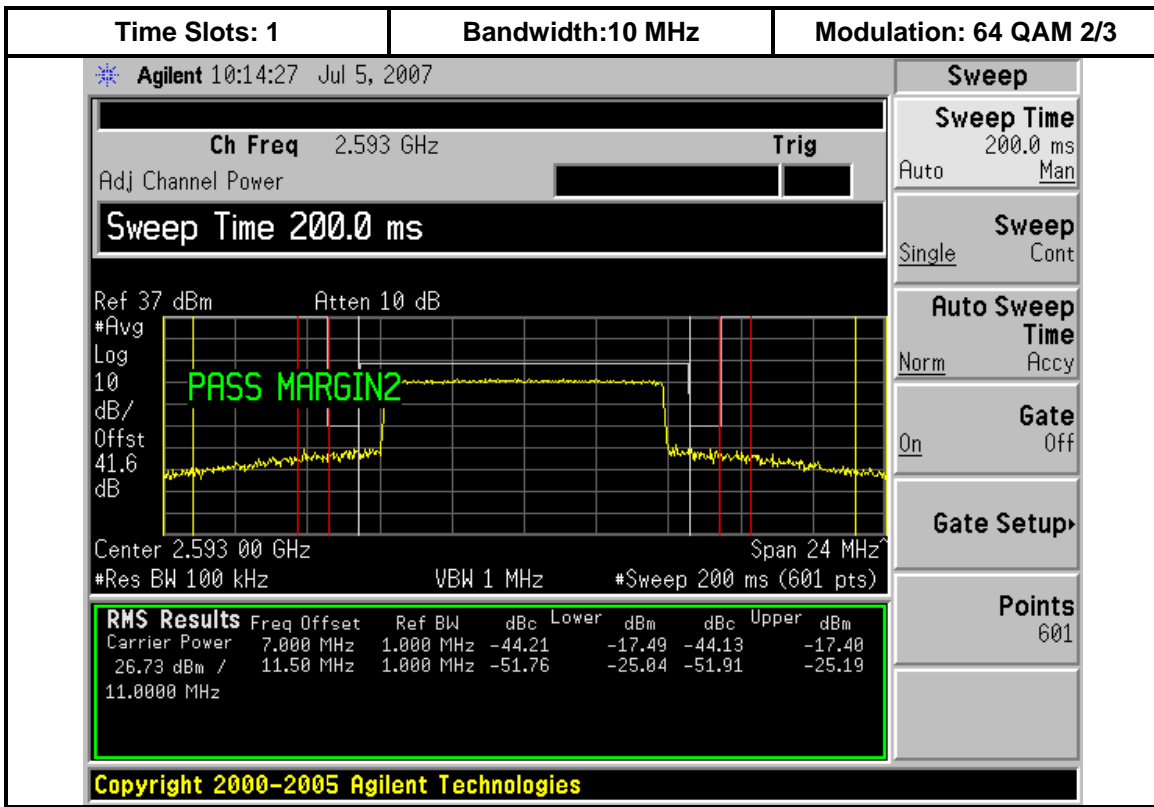

2499 MHz

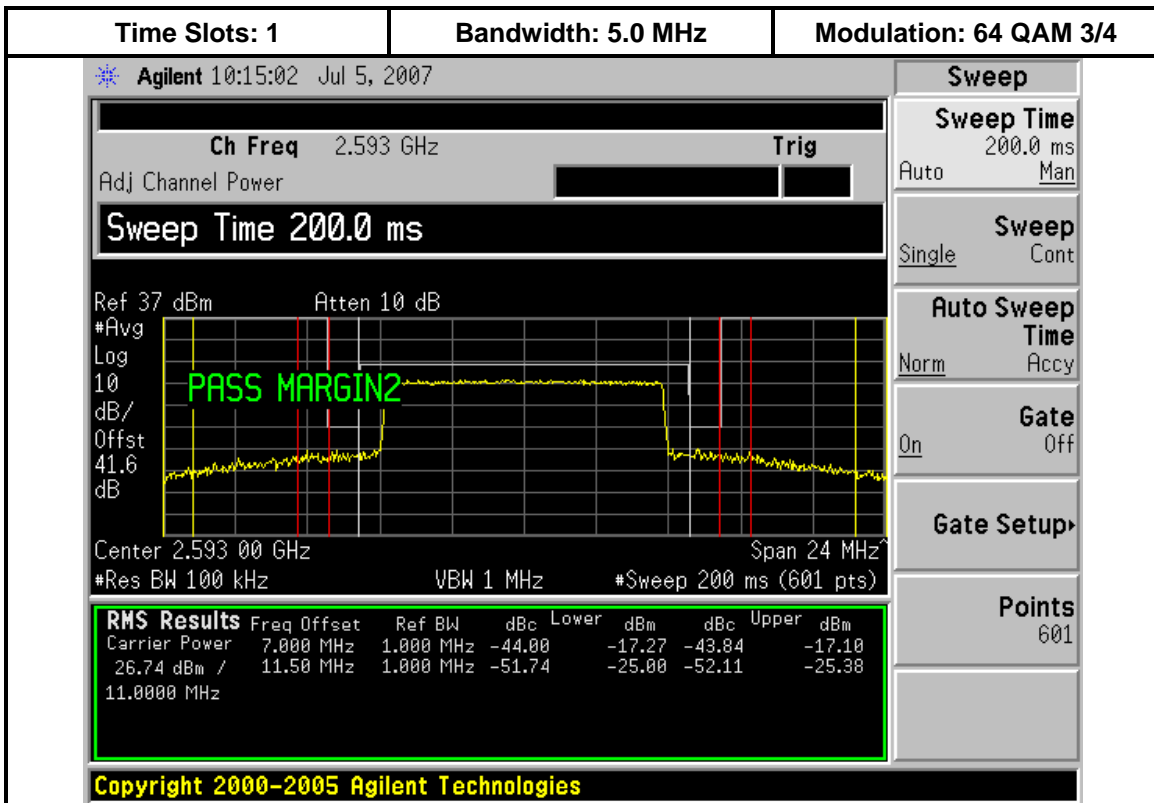

2499 MHz

Minimum Power Level Plots

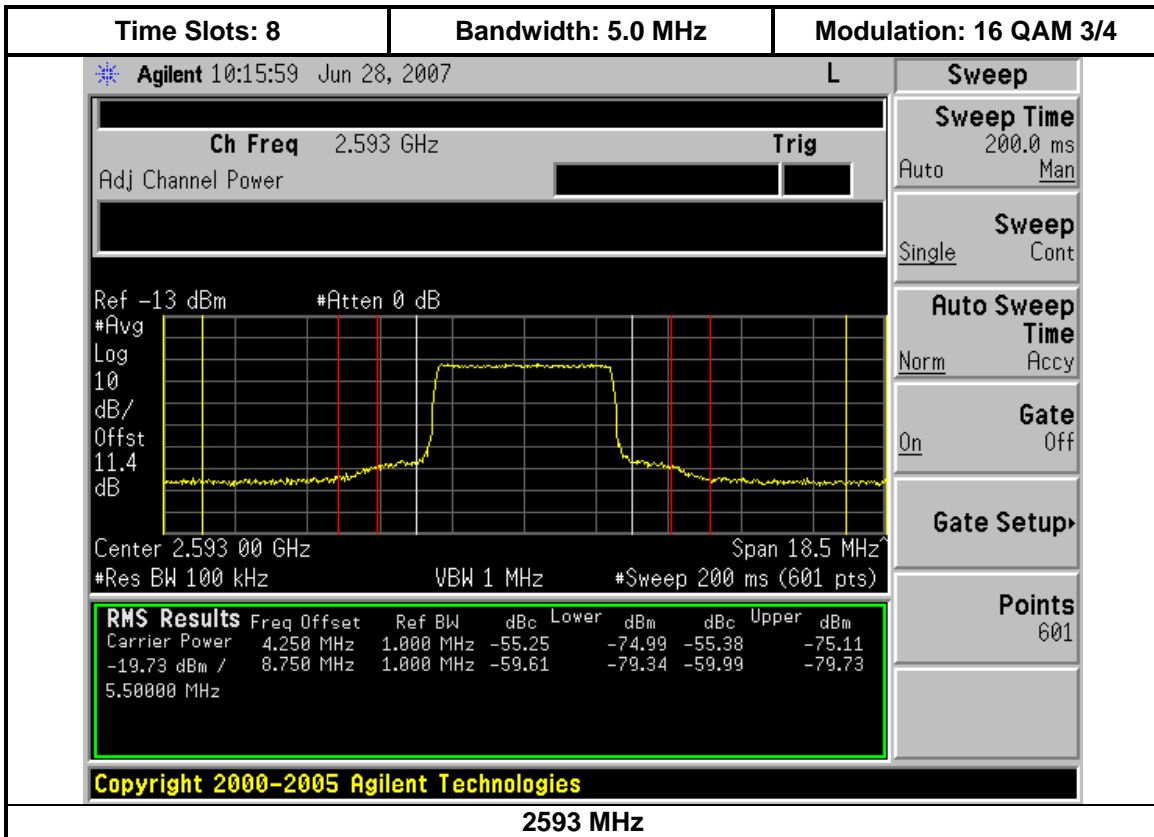
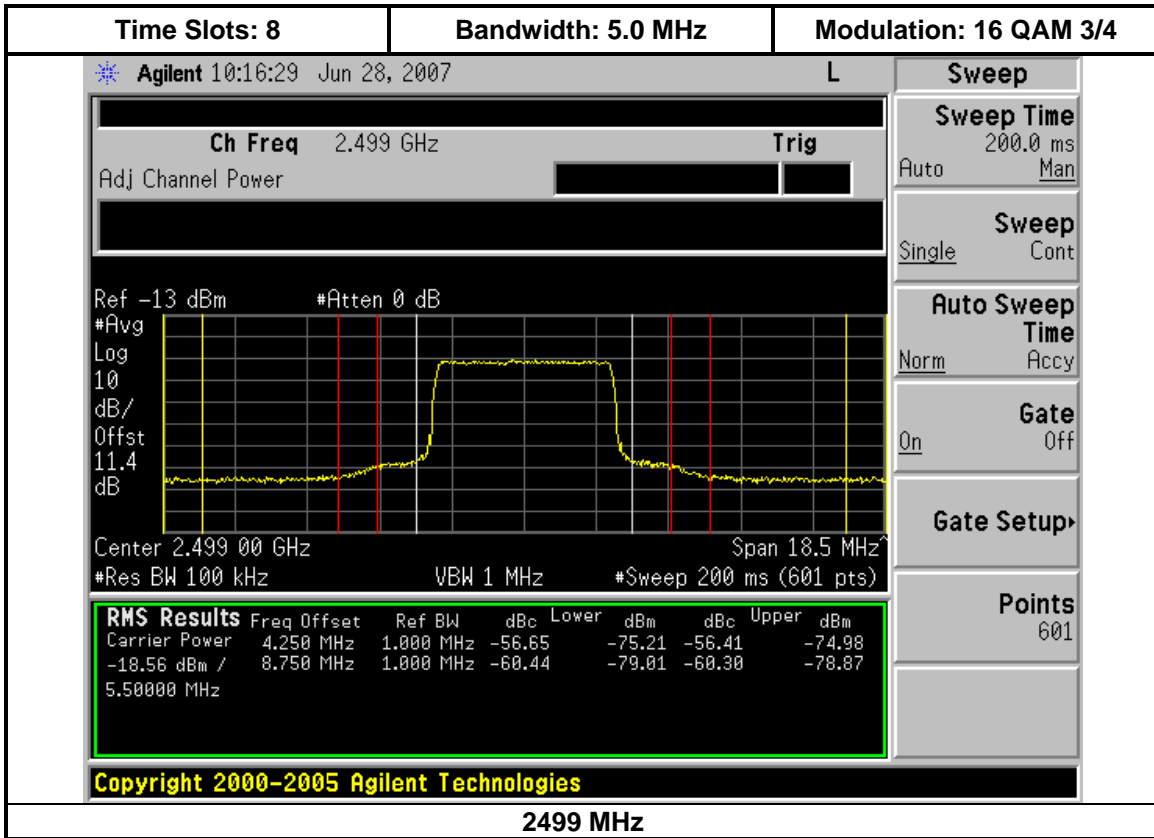

Minimum Power Level Plots (Cont'd)

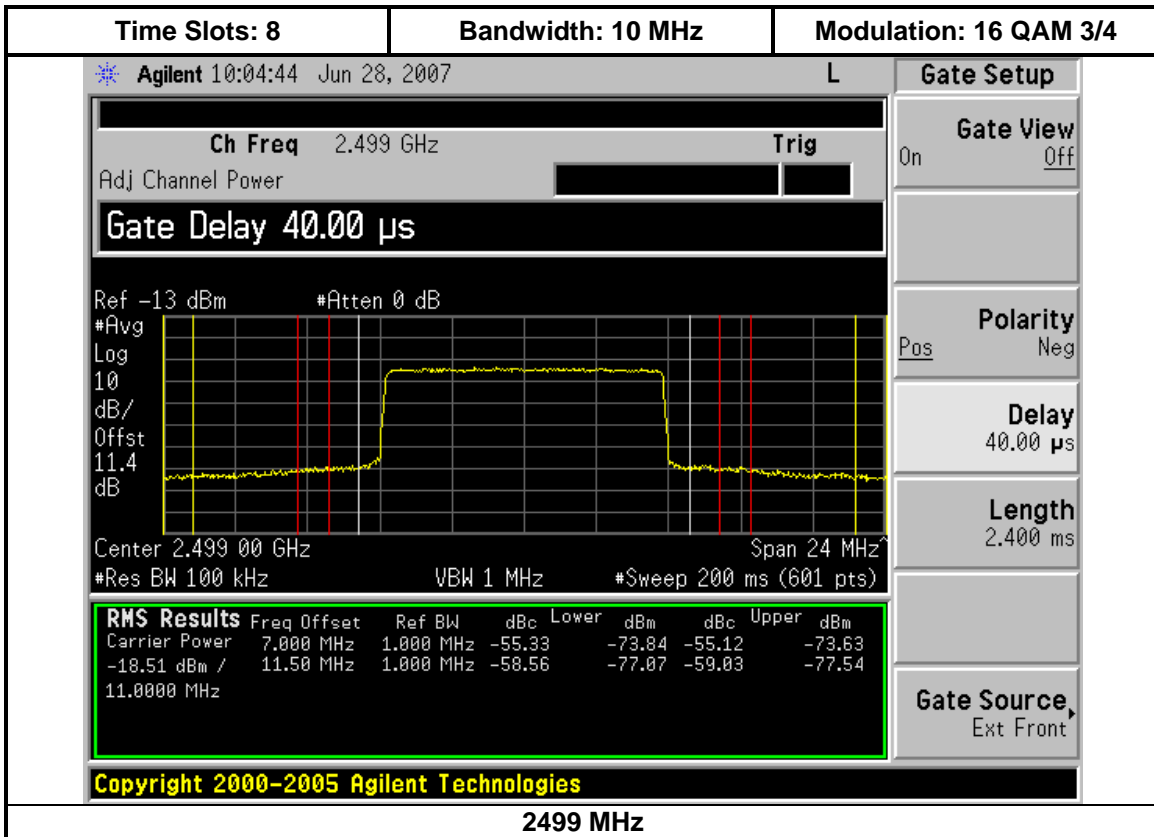
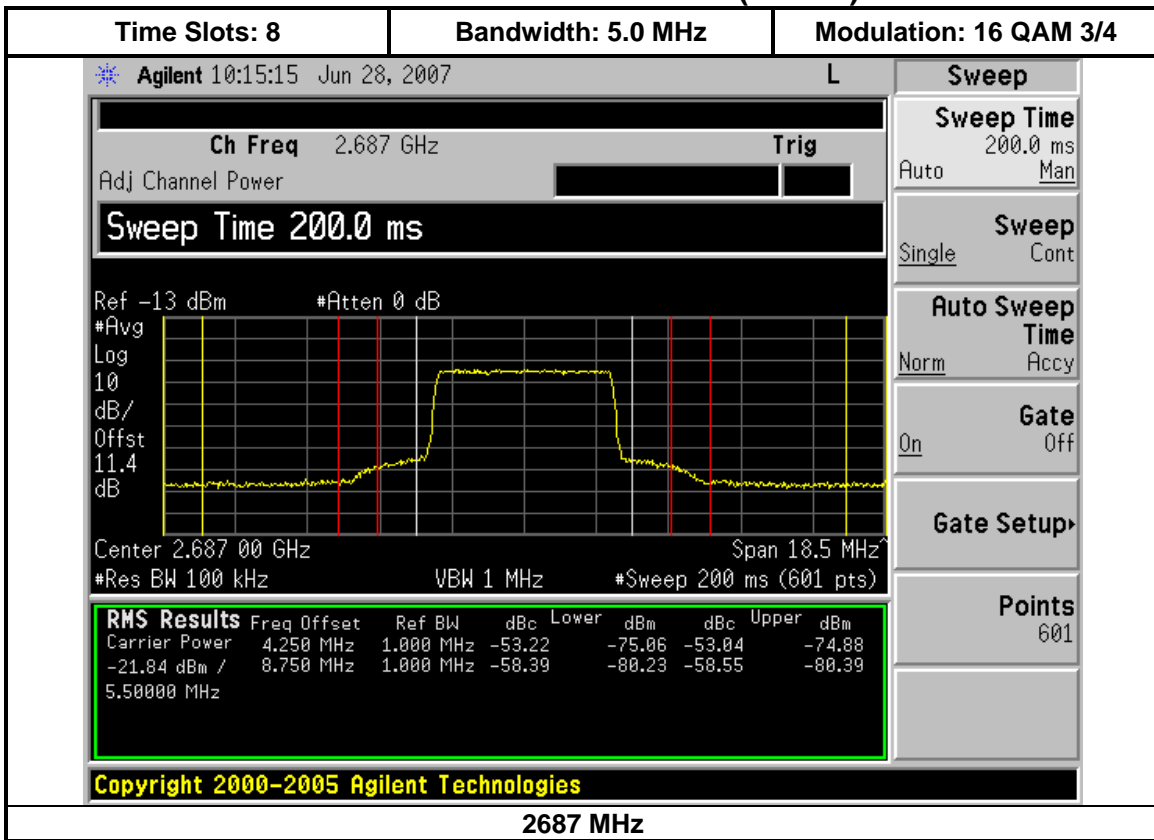

Minimum Power Level Plots (Cont'd)

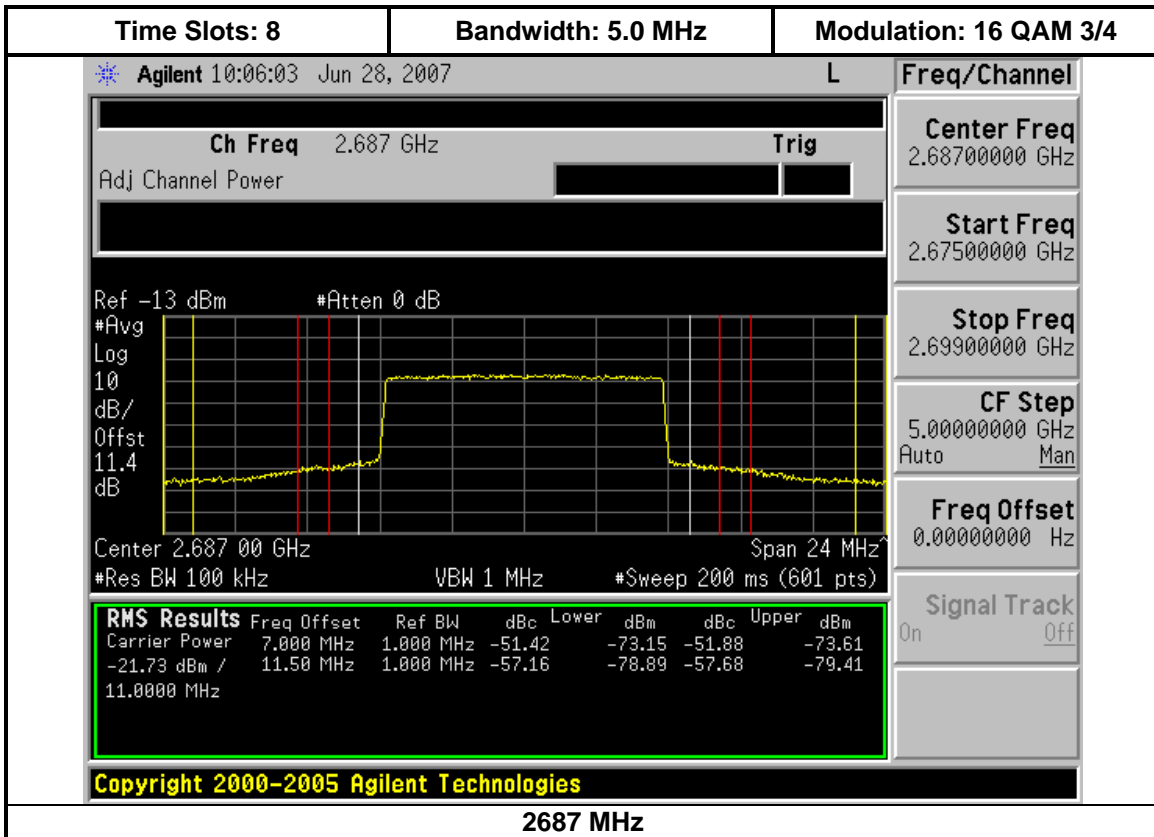
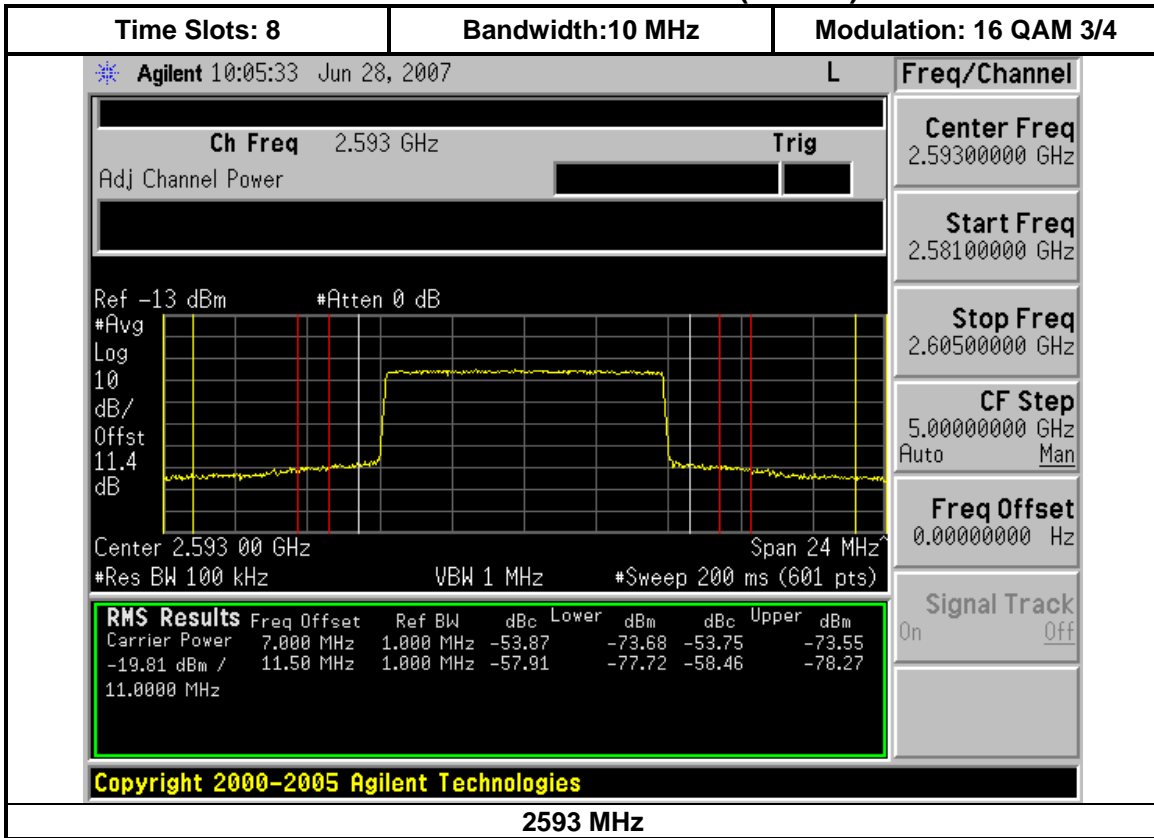

5.3.4. 100 kHz Power Spectral Density Plots

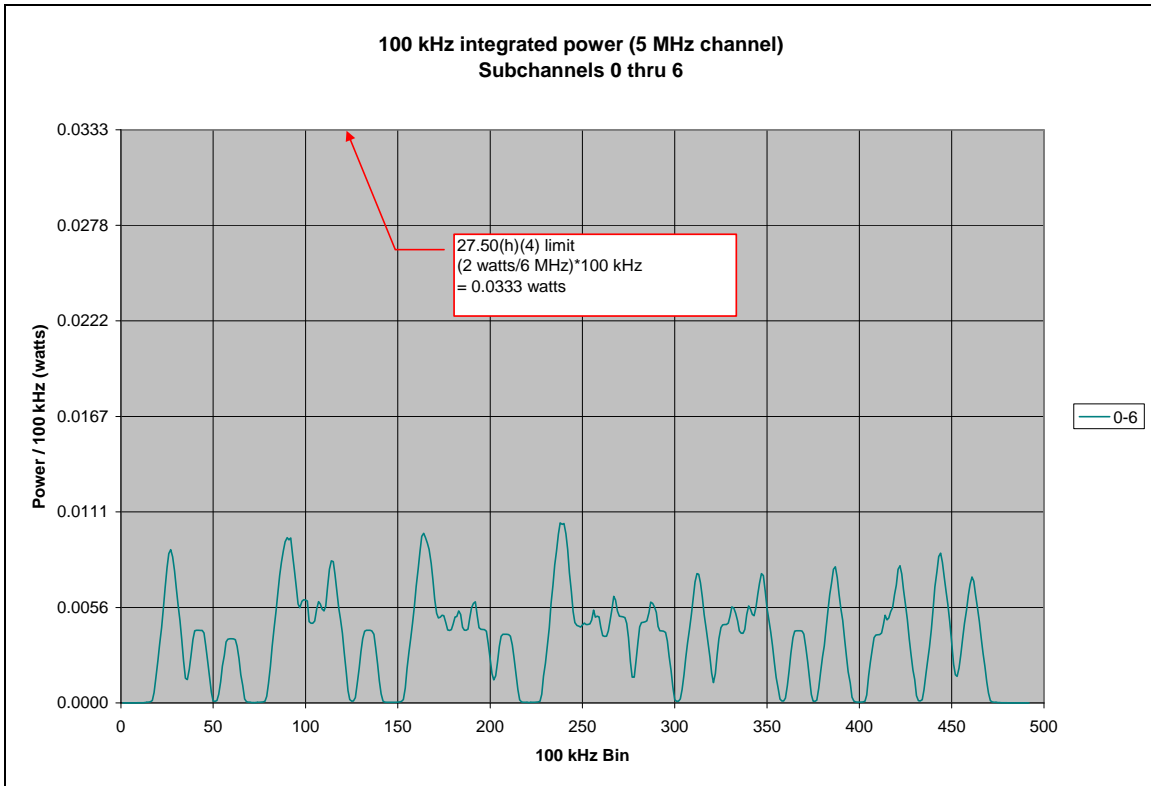

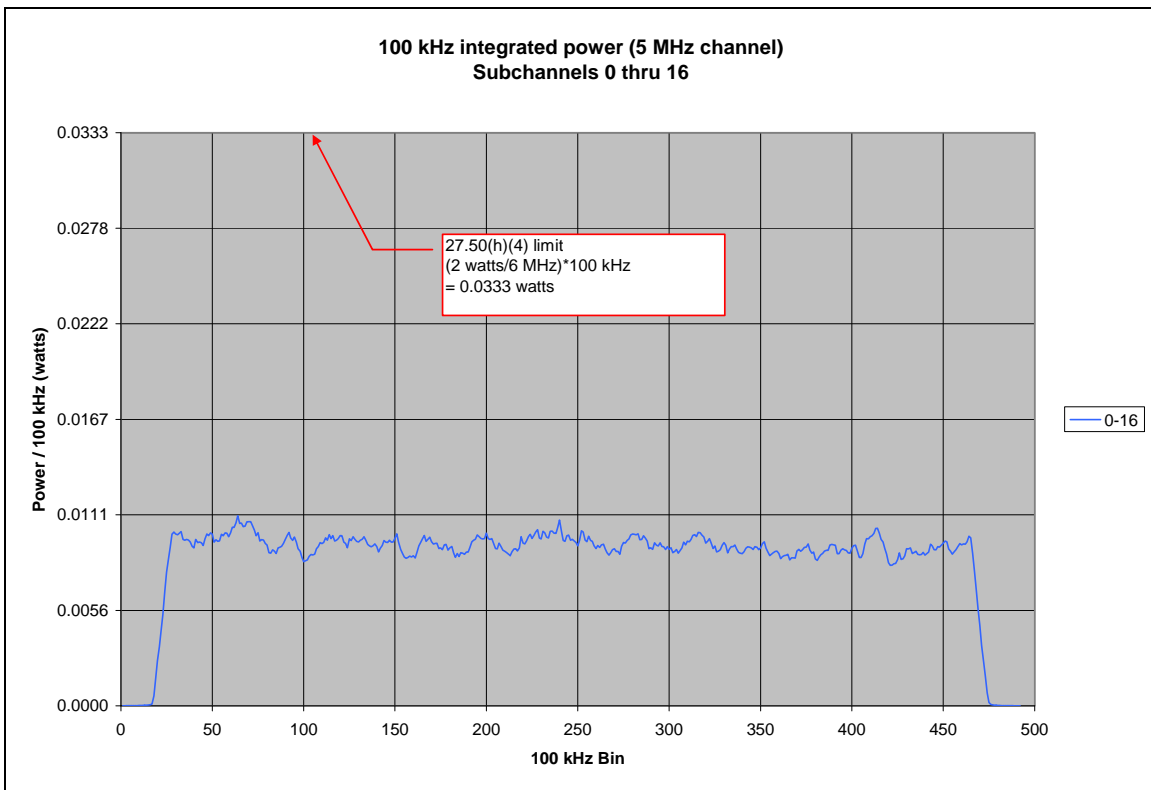
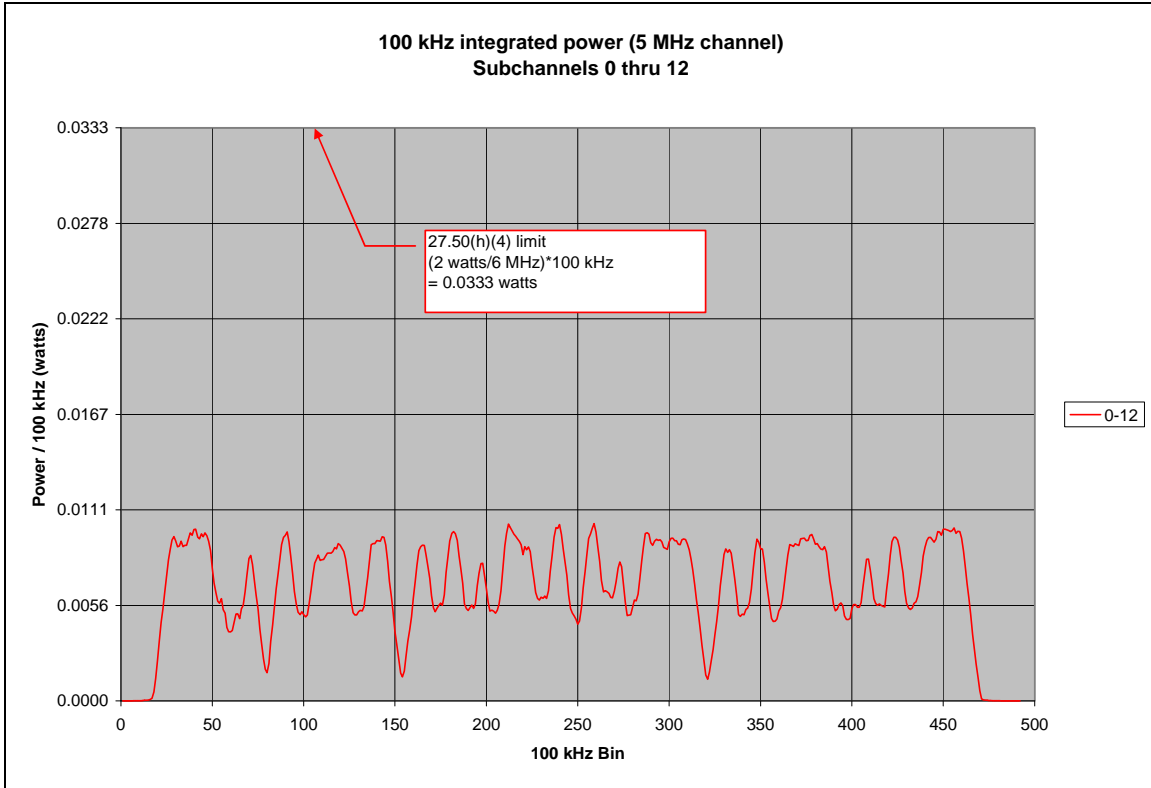

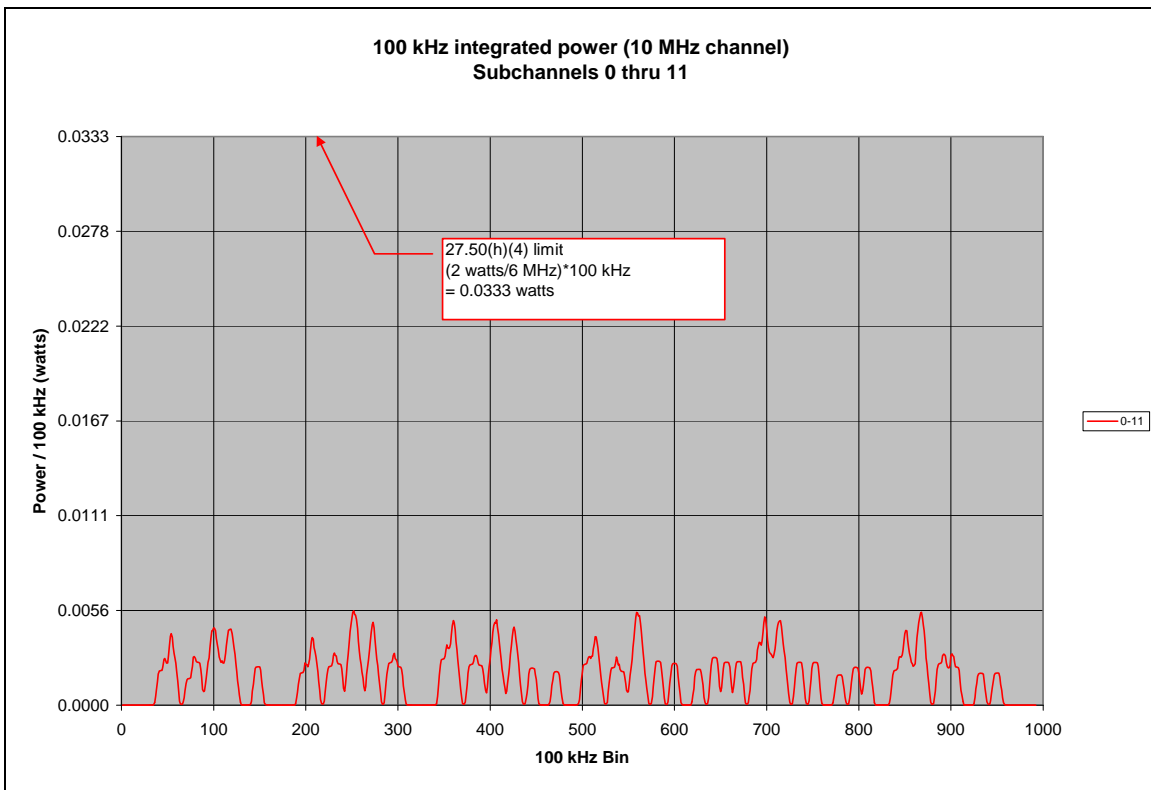
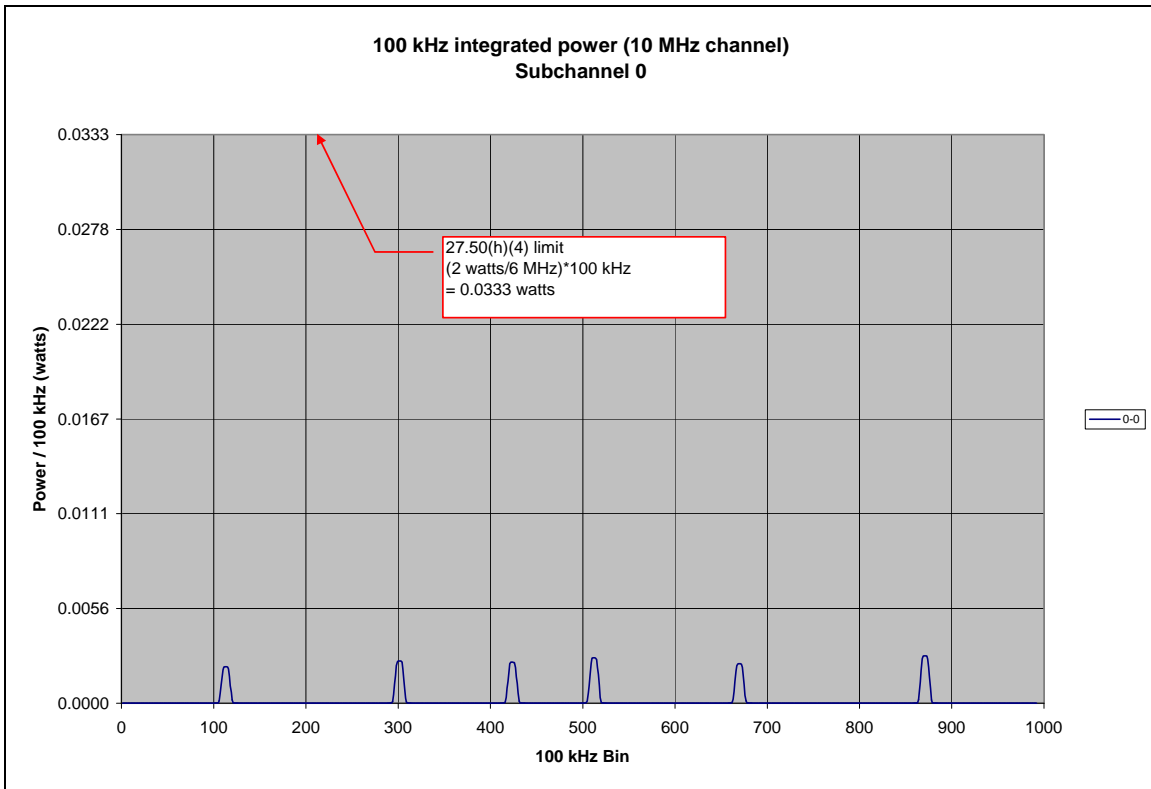

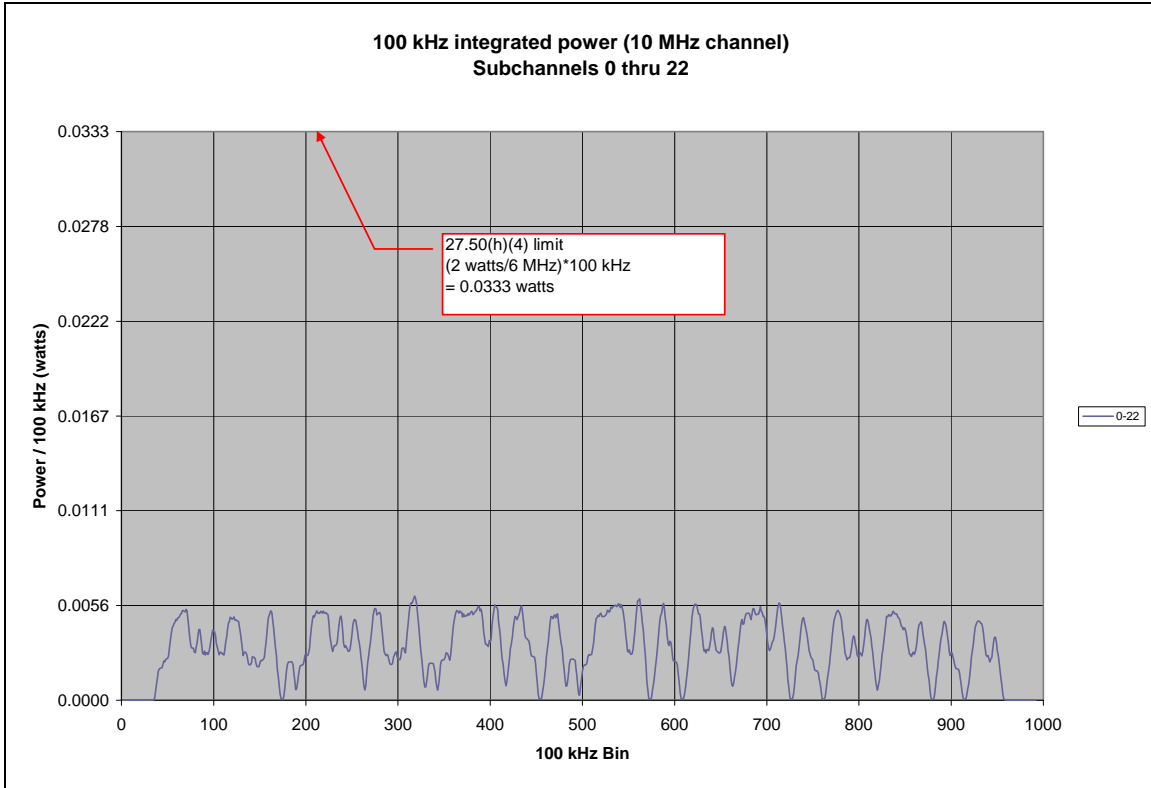

5.4 Modulation Characteristics

FCC Rules: 2.1047(d), 27.53(l)(4), 27.53(l)(6)

FCC requirement: Digital User Station

Attenuation at band edge = $43 + 10 \cdot \log(P)$, $P = 2$ watts

Attenuation at band edge = $43 + 10 \cdot \log(2) = 43 + 3$

Attenuation at band edge = 46 dB (equates to -13 dBm)

Attenuation at 5.5 MHz edge = $55 + 10 \cdot \log(P)$, $P = 2$ watts

Attenuation at 5.5 MHz edge = $55 + 10 \cdot \log(2) = 55 + 3$

Attenuation at 5.5 MHz edge = 58 dB (equates to -25 dBm)

Standard: 47CFR27.53(l)(4)

Test Procedure: The Orthogonal Frequency Division Multiple Access (OFDMA) modulated Time Division Duplex (TDD) RF signal from the test unit is applied to a spectrum analyzer. A detector that has been calibrated in terms of rms-equivalent voltage is used to measure the power of the out of band emission. The emissions have been recorded and show compliance to the -13 dBm requirement. As allowed per the FCC rules, a measurement bandwidth of 100 kHz (1% or greater of the emissions bandwidth) was used for the test.

The Motorola, Inc., RDMi-25100 WiMax transmitter has been designed to comply with the mobile mask requirements of 27.53(l)(4). As such, the FCC mask for the BRS/EBS rules requires the spectral emissions to be less than -13 dBm in any 1 MHz of spectrum from the channel edge to 5.5 MHz from the channel edge and -25 dBm in a 1 MHz bandwidth at 5.5 MHz from the channel edge.

The first 1 MHz of spectral power outside of the channel must be less than -13 dBm when measured with a resolution bandwidth that is at least 1% of the transmitted signal emissions bandwidth. This first 1 MHz of spectrum, designated as bins a/A in the spectral plot shown below, is verified by establishing a limit line at -13 dBm on the spectrum analyzer display. When all emissions in bins a/A are under the -13 dBm limit, a "PASS LIMIT1" (5.0 MHz channel) or "PASS LIMIT2" (10 MHz channel) is displayed. Conversely, a spectral plot with any emissions within bins a/A that are above the -13 dBm limit will produce a "FAIL MARGIN1" or "FAIL MARGIN2" on the display.

All other emissions, shown as bins b/B thru g/G, must be measured with a 1 MHz resolution bandwidth or at least a 1% resolution bandwidth and then integrate the spectral power over a 1 MHz frequency span. The worst case emission for the -13 dBm limit is found at bins b/B. The -25 dBm limit at +/- 5.5 MHz from the channel edge is shown on the plots as bins g/G. The table in section 5.4.1 contains a summary of the plot information for the test configurations.

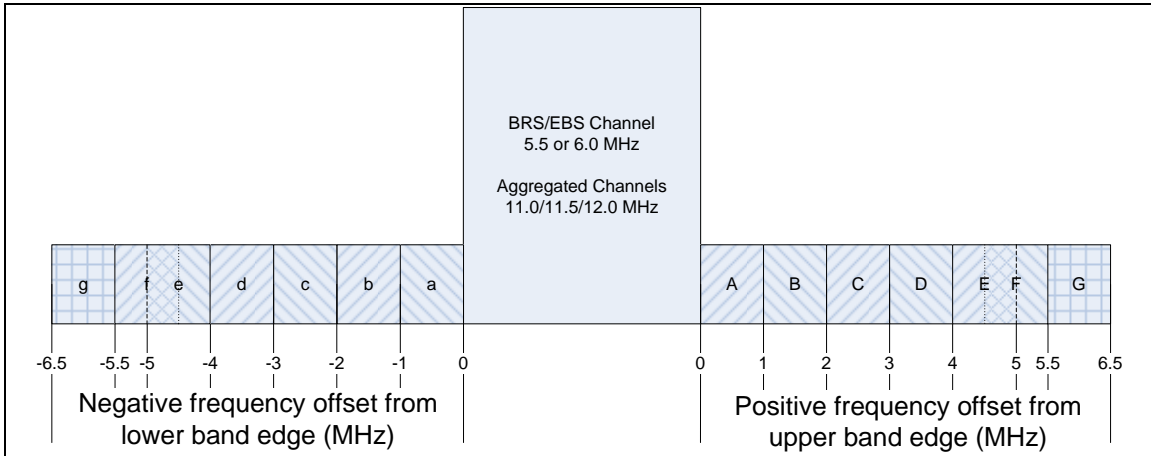

The RDMi-25100 WiMax transmitter is enabled in test mode by the attached computer. The RF loss of the attenuators and coax was measured and is included in the spectrum analyzer amplitude offset and is noted in the block diagram which follows. Measurements are performed at frequencies at the low, mid, and high points of the band and for each of the modulation formats available (QPSK-1/2, QPSK-3/4 and 16 QAM 1/2, 16 QAM 3/4, 64 QAM 1/2, 64 QAM 2/3, and 64QAM 3/4). In addition, measurements were taken with 1 – 8 Time Slots selected and at both channel bandwidths (5.0 and 10 MHz).

Test Conditions: **Test Frequencies:** 2499, 2593, 2687 MHz (5.0 and 10 MHz bandwidth)
 Temperature: 22°C
 Supply Voltage: 120 VAC / 60 Hz Nominal to DUT power supply

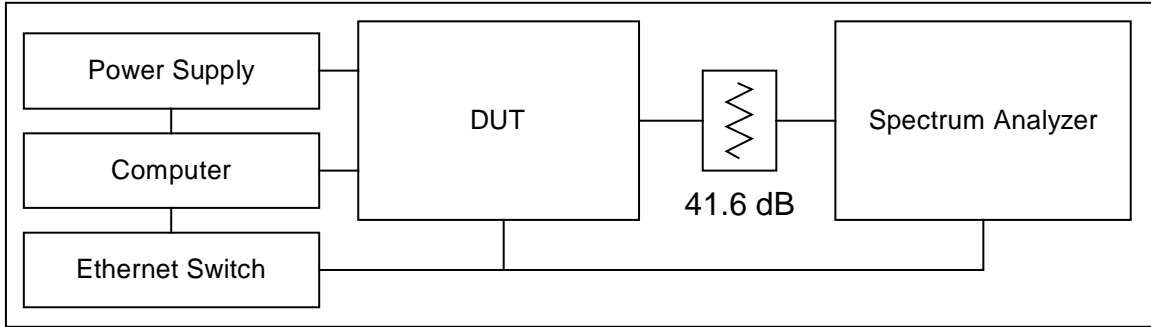

Modulation Characteristics Test Setup

5.4.1. Modulation Characteristics Test Results Summary

The data for all test channels, bandwidths, modulation types, and time slots is shown in the tables which follow.

Modulation Characteristics Summary: Time Slots = 1

Tx Time Slots:		1						
QPSK 1/2								
Fo (MHz)	Channel BW (MHz)	aA	b	B	Margin to -13 dBm limit	g	G	Margin to -25 dBm limit
2499	5	Pass	-13.53	-13.47	0.47	-30.75	-30.85	5.75
2593	5	Pass	-16.99	-16.78	3.78	-33.85	-33.69	8.69
2687	5	Pass	-14.80	-15.03	1.80	-31.57	-31.65	6.57
2499	10	Pass	-18.21	-17.92	4.92	-25.18	-25.14	0.14
2593	10	Pass	-16.96	-17.06	3.96	-25.10	-25.10	0.10
2687	10	Pass	-16.96	-16.88	3.88	-25.92	-26.26	0.92
QPSK 3/4								
Fo (MHz)	Channel BW (MHz)	aA	b	B	Margin to -13 dBm limit	g	G	Margin to -25 dBm limit
2499	5	Pass	-13.47	-13.12	0.12	-30.46	-30.69	5.46
2593	5	Pass	-16.89	-16.83	3.83	-33.99	-34.14	8.99
2687	5	Pass	-14.94	-14.88	1.88	-31.31	-31.91	6.31
2499	10	Pass	-18.69	-18.88	5.69	-25.53	-25.38	0.38
2593	10	Pass	-17.03	-17.34	4.03	-25.07	-25.02	0.02
2687	10	Pass	-16.94	-16.99	3.94	-26.20	-26.13	1.13
16 QAM 1/2								
Fo (MHz)	Channel BW (MHz)	aA	b	B	Margin to -13 dBm limit	g	G	Margin to -25 dBm limit
2499	5	Pass	-13.68	-13.56	0.56	-30.67	-30.94	5.67
2593	5	Pass	-16.58	-17.24	3.58	-33.92	-33.69	8.69
2687	5	Pass	-14.60	-14.49	1.49	-31.52	-31.71	6.52
2499	10	Pass	-18.77	-18.73	5.73	-25.36	-25.49	0.36
2593	10	Pass	-17.10	-17.03	4.03	-25.22	-25.24	0.22
2687	10	Pass	-17.08	-17.24	4.08	-25.84	-26.01	0.84
16 QAM 3/4								
Fo (MHz)	Channel BW (MHz)	aA	b	B	Margin to -13 dBm limit	g	G	Margin to -25 dBm limit
2499	5	Pass	-13.29	-13.53	0.29	-30.41	-31.04	5.41
2593	5	Pass	-16.38	-16.87	3.38	-33.97	-33.49	8.49
2687	5	Pass	-14.41	-14.79	1.41	-31.55	-31.68	6.55
2499	10	Pass	-18.83	-18.56	5.56	-25.33	-25.41	0.33
2593	10	Pass	-17.02	-17.10	4.02	-25.36	-25.23	0.23
2687	10	Pass	-16.86	-17.04	3.86	-25.97	-26.05	0.97
64 QAM 1/2								
Fo (MHz)	Channel BW (MHz)	aA	b	B	Margin to -13 dBm limit	g	G	Margin to -25 dBm limit
2499	5	Pass	-13.54	-13.80	0.54	-30.76	-31.00	5.76
2593	5	Pass	-16.73	-16.90	3.73	-33.74	-34.18	8.74
2687	5	Pass	-14.53	-14.84	1.53	-31.43	-32.03	6.43
2499	10	Pass	-19.17	-18.58	5.58	-25.14	-25.48	0.14
2593	10	Pass	-17.33	-17.22	4.22	-25.12	-25.13	0.12
2687	10	Pass	-17.15	-17.51	4.15	-25.80	-26.28	0.80
64 QAM 2/3								
Fo (MHz)	Channel BW (MHz)	aA	b	B	Margin to -13 dBm limit	g	G	Margin to -25 dBm limit
2499	5	Pass	-13.49	-13.34	0.34	-30.65	-31.18	5.65
2593	5	Pass	-16.71	-17.01	3.71	-33.90	-33.91	8.90
2687	5	Pass	-14.63	-14.56	1.56	-31.65	-32.01	6.65
2499	10	Pass	-18.42	-18.32	5.32	-25.15	-25.32	0.15
2593	10	Pass	-17.49	-17.40	4.40	-25.04	-25.19	0.04
2687	10	Pass	-17.03	-17.29	4.03	-26.05	-26.20	1.05
64 QAM 3/4								
Fo (MHz)	Channel BW (MHz)	aA	b	B	Margin to -13 dBm limit	g	G	Margin to -25 dBm limit
2499	5	Pass	-13.67	-13.26	0.26	-30.71	-31.15	5.71
2593	5	Pass	-16.99	-16.86	3.86	-33.91	-34.46	8.91
2687	5	Pass	-15.21	-14.47	1.47	-31.24	-31.49	6.24
2499	10	Pass	-18.63	-18.39	5.39	-25.46	-25.73	0.46
2593	10	Pass	-17.27	-17.10	4.10	-25.00	-25.38	0.00
2687	10	Pass	-17.04	-17.19	4.04	-26.30	-26.23	1.23

Modulation Characteristics Summary: Time Slots = 2

Tx Time Slots:		2						
QPSK 1/2								
Fo (MHz)	Channel BW (MHz)	aA	b	B	Margin to -13 dBm limit	g	G	Margin to -25 dBm limit
2499	5	Pass	-13.50	-13.70	0.50	-30.62	-30.91	5.62
2593	5	Pass	-16.88	-16.89	3.88	-33.71	-34.20	8.71
2687	5	Pass	-14.12	-14.61	1.12	-31.26	-31.78	6.26
2499	10	Pass	-17.92	-18.38	4.92	-25.18	-25.60	0.18
2593	10	Pass	-17.38	-18.29	4.38	-25.23	-25.83	0.23
2687	10	Pass	-17.04	-17.08	4.04	-25.94	-26.47	0.94
QPSK 3/4								
Fo (MHz)	Channel BW (MHz)	aA	b	B	Margin to -13 dBm limit	g	G	Margin to -25 dBm limit
2499	5	Pass	-13.36	-13.12	0.12	-30.57	-30.77	5.57
2593	5	Pass	-16.84	-16.61	3.61	-33.71	-34.02	8.71
2687	5	Pass	-14.70	-14.70	1.70	-31.44	-31.71	6.44
2499	10	Pass	-18.86	-18.53	5.53	-25.62	-25.79	0.62
2593	10	Pass	-17.39	-17.27	4.27	-25.10	-25.06	0.06
2687	10	Pass	-17.05	-17.02	4.02	-25.96	-26.17	0.96
16 QAM 1/2								
Fo (MHz)	Channel BW (MHz)	aA	b	B	Margin to -13 dBm limit	g	G	Margin to -25 dBm limit
2499	5	Pass	-13.28	-13.68	0.28	-30.61	-30.76	5.61
2593	5	Pass	-17.00	-16.35	3.35	-33.84	-34.25	8.84
2687	5	Pass	-14.85	-14.91	1.85	-32.01	-32.24	7.01
2499	10	Pass	-18.92	-18.56	5.56	-25.38	-25.77	0.38
2593	10	Pass	-17.27	-17.01	4.01	-25.04	-25.60	0.04
2687	10	Pass	-17.09	-17.17	4.09	-26.07	-26.49	1.07
16 QAM 3/4								
Fo (MHz)	Channel BW (MHz)	aA	b	B	Margin to -13 dBm limit	g	G	Margin to -25 dBm limit
2499	5	Pass	-13.39	-13.37	0.37	-30.49	-31.11	5.49
2593	5	Pass	-16.74	-16.97	3.74	-33.77	-34.38	8.77
2687	5	Pass	-14.41	-14.93	1.41	-31.50	-31.78	6.50
2499	10	Pass	-18.95	-18.85	5.85	-25.11	-25.45	0.11
2593	10	Pass	-17.39	-17.16	4.16	-25.08	-25.16	0.08
2687	10	Pass	-16.91	-17.18	3.91	-25.89	-26.17	0.89
64 QAM 1/2								
Fo (MHz)	Channel BW (MHz)	aA	b	B	Margin to -13 dBm limit	g	G	Margin to -25 dBm limit
2499	5	Pass	-13.31	-13.40	0.31	-30.64	-31.20	5.64
2593	5	Pass	-16.96	-17.23	3.96	-33.76	-34.17	8.76
2687	5	Pass	-14.98	-15.35	1.98	-31.79	-32.10	6.79
2499	10	Pass	-18.90	-18.64	5.64	-25.60	-26.31	0.60
2593	10	Pass	-16.94	-17.69	3.94	-25.18	-25.53	0.18
2687	10	Pass	-17.20	-17.36	4.20	-26.22	-26.50	1.22
64 QAM 2/3								
Fo (MHz)	Channel BW (MHz)	aA	b	B	Margin to -13 dBm limit	g	G	Margin to -25 dBm limit
2499	5	Pass	-13.13	-13.46	0.13	-30.96	-31.43	5.96
2593	5	Pass	-17.27	-17.22	4.22	-34.18	-34.43	9.18
2687	5	Pass	-14.77	-14.72	1.72	-31.73	-32.03	6.73
2499	10	Pass	-18.53	-18.43	5.43	-25.44	-25.93	0.44
2593	10	Pass	-17.23	-17.35	4.23	-25.34	-25.36	0.34
2687	10	Pass	-17.20	-17.12	4.12	-26.12	-25.63	0.63
64 QAM 3/4								
Fo (MHz)	Channel BW (MHz)	aA	b	B	Margin to -13 dBm limit	g	G	Margin to -25 dBm limit
2499	5	Pass	-13.90	-13.71	0.71	-30.70	-31.44	5.70
2593	5	Pass	-16.65	-17.34	3.65	-33.96	-34.02	8.96
2687	5	Pass	-14.87	-15.39	1.87	-31.46	-31.74	6.46
2499	10	Pass	-18.45	-18.35	5.35	-25.25	-25.98	0.25
2593	10	Pass	-17.12	-17.33	4.12	-25.32	-25.19	0.19
2687	10	Pass	-17.46	-17.38	4.38	-25.85	-25.92	0.85

Modulation Characteristics Summary: Time Slots = 3

Tx Time Slots:		3						
QPSK 1/2								
Fo (MHz)	Channel BW (MHz)	aA	b	B	Margin to -13 dBm limit	g	G	Margin to -25 dBm limit
2499	5	Pass	-13.08	-13.49	0.08	-30.35	-31.16	5.35
2593	5	Pass	-16.85	-16.89	3.85	-33.85	-34.43	8.85
2687	5	Pass	-14.78	-14.79	1.78	-31.83	-32.09	6.83
2499	10	Pass	-18.46	-18.61	5.46	-25.28	-25.68	0.28
2593	10	Pass	-17.46	-17.59	4.46	-25.15	-25.24	0.15
2687	10	Pass	-17.18	-17.07	4.07	-25.70	-26.42	0.70
QPSK 3/4								
Fo (MHz)	Channel BW (MHz)	aA	b	B	Margin to -13 dBm limit	g	G	Margin to -25 dBm limit
2499	5	Pass	-13.73	-13.47	0.47	-31.01	-31.31	6.01
2593	5	Pass	-16.62	-16.98	3.62	-33.92	-34.46	8.92
2687	5	Pass	-14.94	-14.64	1.64	-31.59	-32.07	6.59
2499	10	Pass	-18.50	-18.35	5.35	-25.42	-25.62	0.42
2593	10	Pass	-17.35	-17.35	4.35	-25.43	-28.45	0.43
2687	10	Pass	-17.04	-17.12	4.04	-26.24	-26.45	1.24
16 QAM 1/2								
Fo (MHz)	Channel BW (MHz)	aA	b	B	Margin to -13 dBm limit	g	G	Margin to -25 dBm limit
2499	5	Pass	-13.08	-14.05	0.08	-30.72	-30.84	5.72
2593	5	Pass	-16.87	-17.45	3.87	-33.88	-34.56	8.88
2687	5	Pass	-14.32	-15.07	1.32	-31.84	-32.05	6.84
2499	10	Pass	-18.35	-18.62	5.35	-25.56	-26.16	0.56
2593	10	Pass	-17.91	-17.44	4.44	-25.33	-25.16	0.16
2687	10	Pass	-17.14	-16.69	3.69	-25.87	-26.46	0.87
16 QAM 3/4								
Fo (MHz)	Channel BW (MHz)	aA	b	B	Margin to -13 dBm limit	g	G	Margin to -25 dBm limit
2499	5	Pass	-13.19	-13.79	0.19	-30.98	-31.52	5.98
2593	5	Pass	-17.16	-16.40	3.40	-34.38	-34.63	9.38
2687	5	Pass	-15.18	-14.73	1.73	-31.98	-32.15	6.98
2499	10	Pass	-18.02	-18.71	5.02	-25.15	-25.26	0.15
2593	10	Pass	-17.26	-17.72	4.26	-25.33	-25.35	0.33
2687	10	Pass	-17.31	-17.15	4.15	-25.56	-26.53	0.56
64 QAM 1/2								
Fo (MHz)	Channel BW (MHz)	aA	b	B	Margin to -13 dBm limit	g	G	Margin to -25 dBm limit
2499	5	Pass	-13.55	-14.31	0.55	-31.16	-31.63	6.16
2593	5	Pass	-16.91	-18.07	3.91	-34.39	-34.03	9.03
2687	5	Pass	-15.01	-14.94	1.94	-32.20	-32.42	7.20
2499	10	Pass	-18.46	-18.28	5.28	-25.63	-25.58	0.58
2593	10	Pass	-17.19	-17.02	4.02	-25.27	-25.97	0.27
2687	10	Pass	-17.41	-16.98	3.98	-26.22	-26.29	1.22
64 QAM 2/3								
Fo (MHz)	Channel BW (MHz)	aA	b	B	Margin to -13 dBm limit	g	G	Margin to -25 dBm limit
2499	5	Pass	-13.82	-13.09	0.09	-30.68	-30.99	5.68
2593	5	Pass	-17.36	-17.09	4.09	-33.81	-34.05	8.81
2687	5	Pass	-15.39	-14.98	1.98	-32.67	-32.25	7.25
2499	10	Pass	-18.75	-18.67	5.67	-25.01	-25.56	0.01
2593	10	Pass	-17.88	-16.67	3.67	-25.35	-25.04	0.04
2687	10	Pass	-16.91	-17.26	3.91	-25.77	-26.13	0.77
64 QAM 3/4								
Fo (MHz)	Channel BW (MHz)	aA	b	B	Margin to -13 dBm limit	g	G	Margin to -25 dBm limit
2499	5	Pass	-13.96	-13.00	0.00	-31.00	-31.13	6.00
2593	5	Pass	-17.31	-17.22	4.22	-34.23	-34.40	9.23
2687	5	Pass	-14.68	-14.42	1.42	-31.94	-32.31	6.94
2499	10	Pass	-19.18	-18.15	5.15	-25.45	-26.07	0.45
2593	10	Pass	-17.21	-17.50	4.21	-25.33	-25.34	0.33
2687	10	Pass	-17.25	-16.74	3.74	-26.66	-25.88	0.88

Modulation Characteristics Summary: Time Slots = 4

Tx Time Slots:		4.00						
QPSK 1/2								
Fo (MHz)	Channel BW (MHz)	aA	b	B	Margin to -13 dBm limit	g	G	Margin to -25 dBm limit
2499	5	Pass	-14.07	-13.91	0.91	-31.41	-31.92	6.41
2593	5	Pass	-17.16	-17.16	4.16	-34.41	-34.59	9.41
2687	5	Pass	-15.37	-14.87	1.87	-32.39	-32.57	7.39
2499	10	Pass	-18.42	-18.13	5.13	-25.60	-25.49	0.49
2593	10	Pass	-16.98	-17.02	3.98	-25.00	-25.06	0.00
2687	10	Pass	-16.87	-17.19	3.87	-26.13	-26.56	1.13
QPSK 3/4								
Fo (MHz)	Channel BW (MHz)	aA	b	B	Margin to -13 dBm limit	g	G	Margin to -25 dBm limit
2499	5	Pass	-13.00	-13.66	0.00	-31.19	-31.38	6.19
2593	5	Pass	-16.94	-17.29	3.94	-34.21	-34.69	9.21
2687	5	Pass	-14.51	-15.11	1.51	-32.14	-32.22	7.14
2499	10	Pass	-18.86	-18.57	5.57	-25.76	-25.50	0.50
2593	10	Pass	-17.52	-17.46	4.46	-25.44	-25.23	0.23
2687	10	Pass	-17.02	-17.16	4.02	-26.47	-26.59	1.47
16 QAM 1/2								
Fo (MHz)	Channel BW (MHz)	aA	b	B	Margin to -13 dBm limit	g	G	Margin to -25 dBm limit
2499	5	Pass	-13.88	-14.09	0.88	-31.54	-31.71	6.54
2593	5	Pass	-17.16	-17.38	4.16	-34.29	-34.51	9.29
2687	5	Pass	-15.07	-15.35	2.07	-32.08	-32.63	7.08
2499	10	Pass	-18.89	-19.17	5.89	-25.14	-25.69	0.14
2593	10	Pass	-17.81	-17.51	4.51	-25.93	-25.34	0.34
2687	10	Pass	-17.41	-17.32	4.32	-26.05	-26.52	1.05
16 QAM 3/4								
Fo (MHz)	Channel BW (MHz)	aA	b	B	Margin to -13 dBm limit	g	G	Margin to -25 dBm limit
2499	5	Pass	-13.55	-13.94	0.55	-30.34	-31.17	5.34
2593	5	Pass	-16.89	-16.67	3.67	-34.30	-34.15	9.15
2687	5	Pass	-15.25	-14.57	1.57	-32.24	-32.53	7.24
2499	10	Pass	-18.90	-17.92	4.92	-25.20	-25.95	0.20
2593	10	Pass	-17.87	-18.18	4.87	-25.94	-25.45	0.45
2687	10	Pass	-17.15	-16.71	3.71	-26.39	-26.10	1.10
64 QAM 1/2								
Fo (MHz)	Channel BW (MHz)	aA	b	B	Margin to -13 dBm limit	g	G	Margin to -25 dBm limit
2499	5	Pass	-13.59	-14.26	0.59	-31.58	-31.53	6.53
2593	5	Pass	-17.70	-17.52	4.52	-34.19	-34.47	9.19
2687	5	Pass	-14.91	-15.51	1.91	-31.69	-31.59	6.59
2499	10	Pass	-18.93	-18.97	5.93	-26.01	-25.55	0.55
2593	10	Pass	-17.68	-18.08	4.68	-25.87	-25.95	0.87
2687	10	Pass	-17.46	-17.52	4.46	-26.19	-27.19	1.19
64 QAM 2/3								
Fo (MHz)	Channel BW (MHz)	aA	b	B	Margin to -13 dBm limit	g	G	Margin to -25 dBm limit
2499	5	Pass	-14.00	-13.53	0.53	-31.41	-31.49	6.41
2593	5	Pass	-17.88	-16.80	3.80	-34.05	-34.67	9.05
2687	5	Pass	-14.81	-15.55	1.81	-31.48	-32.59	6.48
2499	10	Pass	-17.50	-18.62	4.50	-25.75	-26.36	0.75
2593	10	Pass	-16.86	-17.78	3.86	-26.26	-25.30	0.30
2687	10	Pass	-17.21	-17.70	4.21	-26.63	-26.59	1.59
64 QAM 3/4								
Fo (MHz)	Channel BW (MHz)	aA	b	B	Margin to -13 dBm limit	g	G	Margin to -25 dBm limit
2499	5	Pass	-13.72	-13.39	0.39	-30.55	-31.46	5.55
2593	5	Pass	-17.41	-14.54	1.54	-34.16	-34.12	9.12
2687	5	Pass	-15.12	-15.02	2.02	-32.71	-32.41	7.41
2499	10	Pass	-18.88	-18.96	5.88	-26.24	-25.79	0.79
2593	10	Pass	-18.41	-17.80	4.80	-25.45	-25.70	0.45
2687	10	Pass	-17.06	-17.74	4.06	-26.37	-27.37	1.37

Modulation Characteristics Summary: Time Slots = 5

Tx Time Slots:		5						
QPSK 1/2								
Fo (MHz)	Channel BW (MHz)	aA	b	B	Margin to -13 dBm limit	g	G	Margin to -25 dBm limit
2499	5	Pass	-14.38	-14.16	1.16	-31.74	-32.17	6.74
2593	5	Pass	-17.51	-17.28	4.28	-34.17	-34.72	9.17
2687	5	Pass	-15.23	-15.23	2.23	-32.36	-32.64	7.36
2499	10	Pass	-19.43	-19.64	6.43	-26.72	-26.81	1.72
2593	10	Pass	-17.66	-17.85	4.66	-26.12	-25.99	0.99
2687	10	Pass	-17.06	-16.97	3.97	-26.25	-26.58	1.25
QPSK 3/4								
Fo (MHz)	Channel BW (MHz)	aA	b	B	Margin to -13 dBm limit	g	G	Margin to -25 dBm limit
2499	5	Pass	-13.88	-14.28	0.88	-31.47	-31.86	6.47
2593	5	Pass	-17.23	-17.33	4.23	-33.97	-34.49	8.97
2687	5	Pass	-14.97	-15.11	1.97	-32.26	-32.64	7.26
2499	10	Pass	-19.48	-19.54	6.48	-26.46	-27.10	1.46
2593	10	Pass	-17.78	-17.88	4.78	-25.66	-26.21	0.66
2687	10	Pass	-16.91	-17.01	3.91	-26.07	-26.52	1.07
16 QAM 1/2								
Fo (MHz)	Channel BW (MHz)	aA	b	B	Margin to -13 dBm limit	g	G	Margin to -25 dBm limit
2499	5	Pass	-14.18	-13.55	0.55	-31.86	-31.89	6.86
2593	5	Pass	-17.13	-16.95	3.95	-34.55	-34.80	9.55
2687	5	Pass	-15.75	-15.21	2.21	-32.33	-32.67	7.33
2499	10	Pass	-19.59	-19.14	6.14	-25.69	-26.55	0.69
2593	10	Pass	-17.92	-17.45	4.45	-26.04	-25.71	0.71
2687	10	Pass	-17.01	-17.34	4.01	-26.61	-25.71	0.71
16 QAM 3/4								
Fo (MHz)	Channel BW (MHz)	aA	b	B	Margin to -13 dBm limit	g	G	Margin to -25 dBm limit
2499	5	Pass	-14.04	-14.66	1.04	-31.89	-33.10	6.89
2593	5	Pass	-17.14	-17.40	4.14	-34.01	-34.73	9.01
2687	5	Pass	-15.38	-14.46	1.46	-32.22	-33.00	7.22
2499	10	Pass	-19.56	-19.34	6.34	-26.40	-26.44	1.40
2593	10	Pass	-18.24	-18.36	5.24	-25.43	-25.55	0.43
2687	10	Pass	-17.41	-16.93	3.93	-26.64	-26.33	1.33
64 QAM 1/2								
Fo (MHz)	Channel BW (MHz)	aA	b	B	Margin to -13 dBm limit	g	G	Margin to -25 dBm limit
2499	5	Pass	-14.40	-14.63	1.40	-31.92	-32.31	6.92
2593	5	Pass	-17.29	-16.73	3.73	-34.10	-34.93	9.10
2687	5	Pass	-15.47	-15.34	2.34	-31.86	-32.84	6.86
2499	10	Pass	-19.39	-19.72	6.39	-26.58	-26.79	1.58
2593	10	Pass	-17.45	-17.38	4.38	-26.27	-26.02	1.02
2687	10	Pass	-17.35	-17.40	4.35	-26.10	-26.55	1.10
64 QAM 2/3								
Fo (MHz)	Channel BW (MHz)	aA	b	B	Margin to -13 dBm limit	g	G	Margin to -25 dBm limit
2499	5	Pass	-14.07	-13.47	0.47	-31.60	-32.28	6.60
2593	5	Pass	-17.04	-17.21	4.04	-35.04	-35.10	10.04
2687	5	Pass	-15.89	-15.59	2.59	-32.57	-32.22	7.22
2499	10	Pass	-19.15	-19.34	6.15	-26.89	-26.86	1.86
2593	10	Pass	-17.88	-18.64	4.88	-25.84	-26.14	0.84
2687	10	Pass	-17.12	-17.34	4.12	-26.30	-26.36	1.30
64 QAM 3/4								
Fo (MHz)	Channel BW (MHz)	aA	b	B	Margin to -13 dBm limit	g	G	Margin to -25 dBm limit
2499	5	Pass	-14.29	-14.10	1.10	-31.53	-31.89	6.53
2593	5	Pass	-17.92	-17.81	4.81	-34.60	-34.52	9.52
2687	5	Pass	-15.80	-15.82	2.80	-32.37	-32.34	7.34
2499	10	Pass	-19.97	-19.14	6.14	-26.56	-27.42	1.56
2593	10	Pass	-18.23	-18.05	5.05	-26.15	-25.65	0.65
2687	10	Pass	-16.57	-17.36	3.57	-26.97	-26.85	1.85

Modulation Characteristics Summary: Time Slots = 6

Tx Time Slots:		6						
QPSK 1/2								
Fo (MHz)	Channel BW (MHz)	aA	b	B	Margin to -13 dBm limit	g	G	Margin to -25 dBm limit
2499	5	Pass	-14.39	-14.36	1.36	-32.42	-32.59	7.42
2593	5	Pass	-17.08	-17.43	4.08	-34.58	-34.98	9.58
2687	5	Pass	-15.20	-15.57	2.20	-32.68	-32.93	7.68
2499	10	Pass	-18.97	-18.87	5.87	-26.31	-26.47	1.31
2593	10	Pass	-17.77	-17.70	4.70	-25.39	-25.86	0.39
2687	10	Pass	-17.37	-17.47	4.37	-26.69	-27.02	1.69
QPSK 3/4								
Fo (MHz)	Channel BW (MHz)	aA	b	B	Margin to -13 dBm limit	g	G	Margin to -25 dBm limit
2499	5	Pass	-13.75	-14.38	0.75	-31.37	-32.46	6.37
2593	5	Pass	-17.36	-17.64	4.36	-34.53	-34.87	9.53
2687	5	Pass	-15.27	-15.36	2.27	-32.34	-32.79	7.34
2499	10	Pass	-18.98	-18.62	5.62	-25.96	-26.13	0.96
2593	10	Pass	-17.59	-17.88	4.59	-25.41	-25.85	0.41
2687	10	Pass	-17.40	-17.50	4.40	-26.79	-27.06	1.79
16 QAM 1/2								
Fo (MHz)	Channel BW (MHz)	aA	b	B	Margin to -13 dBm limit	g	G	Margin to -25 dBm limit
2499	5	Pass	-14.07	-14.51	1.07	-31.76	-32.93	6.76
2593	5	Pass	-17.86	-17.57	4.57	-34.50	-35.32	9.50
2687	5	Pass	-15.90	-15.52	2.52	-32.28	-33.14	7.28
2499	10	Pass	-18.99	-18.31	5.31	-25.83	-26.55	0.83
2593	10	Pass	-17.63	-17.02	4.02	-25.66	-25.59	0.59
2687	10	Pass	-17.06	-17.80	4.06	-27.06	-26.92	1.92
16 QAM 3/4								
Fo (MHz)	Channel BW (MHz)	aA	b	B	Margin to -13 dBm limit	g	G	Margin to -25 dBm limit
2499	5	Pass	-14.17	-13.60	0.60	-31.74	-32.39	6.74
2593	5	Pass	-17.30	-17.43	4.30	-34.70	-34.79	9.70
2687	5	Pass	-15.71	-15.66	2.66	-32.40	-32.87	7.40
2499	10	Pass	-19.32	-18.38	5.38	-26.04	-26.22	1.04
2593	10	Pass	-18.00	-17.78	4.78	-25.06	-25.58	0.06
2687	10	Pass	-17.18	-18.03	4.18	-26.57	-26.88	1.57
64 QAM 1/2								
Fo (MHz)	Channel BW (MHz)	aA	b	B	Margin to -13 dBm limit	g	G	Margin to -25 dBm limit
2499	5	Pass	-14.03	-14.68	1.03	-31.16	-32.40	6.16
2593	5	Pass	-17.39	-17.84	4.39	-34.91	-34.99	9.91
2687	5	Pass	-16.22	-15.56	2.56	-33.09	-32.90	7.90
2499	10	Pass	-19.44	-18.20	5.20	-25.76	-27.38	0.76
2593	10	Pass	-18.01	-17.95	4.95	-25.70	-26.78	0.70
2687	10	Pass	-17.44	-18.30	4.44	-26.88	-27.13	1.88
64 QAM 2/3								
Fo (MHz)	Channel BW (MHz)	aA	b	B	Margin to -13 dBm limit	g	G	Margin to -25 dBm limit
2499	5	Pass	-14.44	-15.35	1.44	-30.52	-32.49	5.52
2593	5	Pass	-17.52	-18.29	4.52	-33.98	-34.36	8.98
2687	5	Pass	-15.99	-15.93	2.93	-32.18	-33.06	7.18
2499	10	Pass	-19.00	-19.55	6.00	-26.47	-25.78	0.78
2593	10	Pass	-17.95	-17.06	4.06	-25.53	-26.12	0.53
2687	10	Pass	-17.65	-18.12	4.65	-27.62	-27.40	2.40
64 QAM 3/4								
Fo (MHz)	Channel BW (MHz)	aA	b	B	Margin to -13 dBm limit	g	G	Margin to -25 dBm limit
2499	5	Pass	-13.82	-15.18	0.82	-31.71	-32.22	6.71
2593	5	Pass	-17.73	-17.55	4.55	-34.68	-35.17	9.68
2687	5	Pass	-15.83	-15.69	2.69	-32.77	-33.12	7.77
2499	10	Pass	-18.31	-19.85	5.31	-26.19	-27.13	1.19
2593	10	Pass	-17.87	-18.62	4.87	-25.62	-25.94	0.62
2687	10	Pass	-17.61	-18.38	4.61	-26.85	-27.31	1.85

Modulation Characteristics Summary: Time Slots = 7

Tx Time Slots:		7						
QPSK 1/2								
Fo (MHz)	Channel BW (MHz)	aA	b	B	Margin to -13 dBm limit	g	G	Margin to -25 dBm limit
2499	5	Pass	-14.26	-14.32	1.26	-32.05	-32.70	7.05
2593	5	Pass	-17.32	-17.40	4.32	-34.79	-35.53	9.79
2687	5	Pass	-15.40	-15.74	2.40	-32.90	-33.17	7.90
2499	10	Pass	-20.03	-19.75	6.75	-26.99	-27.04	1.99
2593	10	Pass	-17.99	-18.12	4.99	-26.04	-26.37	1.04
2687	10	Pass	-17.35	-17.61	4.35	-26.90	-27.24	1.90
QPSK 3/4								
Fo (MHz)	Channel BW (MHz)	aA	b	B	Margin to -13 dBm limit	g	G	Margin to -25 dBm limit
2499	5	Pass	-14.58	-14.55	1.55	-32.28	-32.79	7.28
2593	5	Pass	-17.48	-17.82	4.48	-34.81	-35.44	9.81
2687	5	Pass	-15.53	-15.82	2.53	-32.85	-33.39	7.85
2499	10	Pass	-19.23	-19.51	6.23	-26.38	-26.80	1.38
2593	10	Pass	-17.94	-18.20	4.94	-25.92	-26.37	0.92
2687	10	Pass	-17.70	-17.91	4.70	-27.04	-27.18	2.04
16 QAM 1/2								
Fo (MHz)	Channel BW (MHz)	aA	b	B	Margin to -13 dBm limit	g	G	Margin to -25 dBm limit
2499	5	Pass	-14.16	-13.94	0.94	-32.31	-32.40	7.31
2593	5	Pass	-17.97	-16.59	3.59	-35.09	-35.21	10.09
2687	5	Pass	-14.92	-15.76	1.92	-33.21	-32.95	7.95
2499	10	Pass	-18.57	-19.54	5.57	-25.90	-26.50	0.90
2593	10	Pass	-17.10	-18.04	4.10	-26.26	-26.10	1.10
2687	10	Pass	-17.43	-18.23	4.43	-27.17	-27.68	2.17
16 QAM 3/4								
Fo (MHz)	Channel BW (MHz)	aA	b	B	Margin to -13 dBm limit	g	G	Margin to -25 dBm limit
2499	5	Pass	-14.41	-14.53	1.41	-32.02	-31.89	6.89
2593	5	Pass	-18.10	-18.17	5.10	-34.73	-35.25	9.73
2687	5	Pass	-15.37	-16.00	2.37	-32.69	-33.24	7.69
2499	10	Pass	-19.71	-20.10	6.71	-26.40	-27.26	1.40
2593	10	Pass	-17.89	-17.77	4.77	-26.01	-26.45	1.01
2687	10	Pass	-17.30	-17.58	4.30	-27.98	-27.77	2.77
64 QAM 1/2								
Fo (MHz)	Channel BW (MHz)	aA	b	B	Margin to -13 dBm limit	g	G	Margin to -25 dBm limit
2499	5	Pass	-14.51	-15.04	1.51	-32.43	-33.23	7.43
2593	5	Pass	-17.11	-17.48	4.11	-35.58	-35.51	10.51
2687	5	Pass	-15.37	-16.12	2.37	-32.95	-33.15	7.95
2499	10	Pass	-18.50	-19.57	5.50	-26.72	-26.73	1.72
2593	10	Pass	-18.43	-18.34	5.34	-25.81	-26.12	0.81
2687	10	Pass	-18.05	-18.09	5.05	-27.19	-27.74	2.19
64 QAM 2/3								
Fo (MHz)	Channel BW (MHz)	aA	b	B	Margin to -13 dBm limit	g	G	Margin to -25 dBm limit
2499	5	Pass	-15.01	-14.91	1.91	-32.34	-32.62	7.34
2593	5	Pass	-18.81	-17.26	4.26	-35.68	-35.17	10.17
2687	5	Pass	-14.85	-16.34	1.85	-32.48	-33.04	7.48
2499	10	Pass	-18.88	-19.33	5.88	-27.23	-26.82	1.82
2593	10	Pass	-18.90	-18.49	5.49	-25.19	-26.22	0.19
2687	10	Pass	-17.66	-18.24	4.66	-26.52	-28.00	1.52
64 QAM 3/4								
Fo (MHz)	Channel BW (MHz)	aA	b	B	Margin to -13 dBm limit	g	G	Margin to -25 dBm limit
2499	5	Pass	-14.73	-15.01	1.73	-32.48	-32.80	7.48
2593	5	Pass	-17.96	-19.18	4.96	-35.31	-35.77	10.31
2687	5	Pass	-15.61	-16.02	2.61	-33.04	-33.18	8.04
2499	10	Pass	-19.10	-19.48	6.10	-27.33	-27.39	2.33
2593	10	Pass	-18.39	-17.85	4.85	-26.28	-26.77	1.28
2687	10	Pass	-17.73	-17.64	4.64	-27.26	-26.64	1.64

Modulation Characteristics Summary: Time Slots = 8

Tx Time Slots:		8						
QPSK 1/2								
Fo (MHz)	Channel BW (MHz)	aA	b	B	Margin to -13 dBm limit	g	G	Margin to -25 dBm limit
2499	5	Pass	-14.99	-14.89	1.89	-32.95	-33.09	7.95
2593	5	Pass	-17.69	-17.87	4.69	-34.67	-35.41	9.67
2687	5	Pass	-15.01	-15.60	2.01	-32.80	-33.25	7.80
2499	10	Pass	-20.07	-19.78	6.78	-27.54	-27.50	2.50
2593	10	Pass	-18.47	-18.15	5.15	-26.48	-26.26	1.26
2687	10	Pass	-17.61	-17.73	4.61	-27.54	-27.73	2.54
QPSK 3/4								
Fo (MHz)	Channel BW (MHz)	aA	b	B	Margin to -13 dBm limit	g	G	Margin to -25 dBm limit
2499	5	Pass	-14.94	-14.59	1.59	-32.69	-33.05	7.69
2593	5	Pass	-18.10	-17.74	4.74	-35.07	-35.74	10.07
2687	5	Pass	-15.55	-15.68	2.55	-33.22	-33.67	8.22
2499	10	Pass	-19.33	-19.91	6.33	-27.00	-27.44	2.00
2593	10	Pass	-18.28	-18.19	5.19	-26.06	-26.54	1.06
2687	10	Pass	-17.69	-17.67	4.67	-27.15	-27.81	2.15
16 QAM 1/2								
Fo (MHz)	Channel BW (MHz)	aA	b	B	Margin to -13 dBm limit	g	G	Margin to -25 dBm limit
2499	5	Pass	-15.13	-14.24	1.24	-32.35	-32.74	7.35
2593	5	Pass	-18.32	-18.25	5.25	-35.32	-35.60	10.32
2687	5	Pass	-15.37	-16.32	2.37	-33.01	-33.19	8.01
2499	10	Pass	-19.84	-19.91	6.84	-26.43	-26.68	1.43
2593	10	Pass	-17.98	-17.77	4.77	-25.98	-25.79	0.79
2687	10	Pass	-17.92	-17.66	4.66	-27.93	-27.64	2.64
16 QAM 3/4								
Fo (MHz)	Channel BW (MHz)	aA	b	B	Margin to -13 dBm limit	g	G	Margin to -25 dBm limit
2499	5	Pass	-14.49	-14.22	1.22	-32.18	-33.05	7.18
2593	5	Pass	-17.36	-17.65	4.36	-35.52	-35.03	10.03
2687	5	Pass	-15.85	-15.67	2.67	-32.88	-33.45	7.88
2499	10	Pass	-19.51	-19.91	6.51	-27.03	-27.24	2.03
2593	10	Pass	-18.53	-17.32	4.32	-26.22	-26.67	1.22
2687	10	Pass	-17.90	-17.94	4.90	-28.10	-28.16	3.10
64 QAM 1/2								
Fo (MHz)	Channel BW (MHz)	aA	b	B	Margin to -13 dBm limit	g	G	Margin to -25 dBm limit
2499	5	Pass	-15.34	-15.57	2.34	-32.44	-32.54	7.44
2593	5	Pass	-18.55	-18.54	5.54	-35.74	-35.24	10.24
2687	5	Pass	-16.28	-16.38	3.28	-33.20	-33.67	8.20
2499	10	Pass	-20.00	-19.75	6.75	-26.57	-27.50	1.57
2593	10	Pass	-18.60	-18.32	5.32	-26.51	-27.13	1.51
2687	10	Pass	-18.54	-18.07	5.07	-28.44	-28.26	3.26
64 QAM 2/3								
Fo (MHz)	Channel BW (MHz)	aA	b	B	Margin to -13 dBm limit	g	G	Margin to -25 dBm limit
2499	5	Pass	-16.11	-15.45	2.45	-33.24	-32.95	7.95
2593	5	Pass	-17.88	-18.32	4.88	-35.50	-35.39	10.39
2687	5	Pass	-15.52	-17.22	2.52	-33.38	-33.07	8.07
2499	10	Pass	-21.29	-19.43	6.43	-26.58	-28.22	1.58
2593	10	Pass	-18.51	-18.27	5.27	-26.42	-26.61	1.42
2687	10	Pass	-18.06	-17.94	4.94	-27.54	-27.80	2.54
64 QAM 3/4								
Fo (MHz)	Channel BW (MHz)	aA	b	B	Margin to -13 dBm limit	g	G	Margin to -25 dBm limit
2499	5	Pass	-13.75	-15.44	0.75	-32.48	-32.65	7.48
2593	5	Pass	-17.94	-18.13	4.94	-34.55	-36.04	9.55
2687	5	Pass	-15.65	-16.24	2.65	-33.59	-33.58	8.58
2499	10	Pass	-19.86	-20.49	6.86	-27.14	-27.19	2.14
2593	10	Pass	-17.44	-18.85	4.44	-26.40	-26.94	1.40
2687	10	Pass	-18.92	-17.94	4.94	-27.84	-28.87	2.84

5.4.2. Modulation Characteristics Data Plots

The same spectrum analyzer plots are also used for RF Power Output (Section 5.3). Therefore, plots are not repeated in this section. Spectrum analyzer plots for 2593 MHz, Time Slots = 1, and all seven modulation types are displayed for 5.0 and 10 MHz bandwidth channels starting on page 11.

Additional plots are shown in Appendix B (“Conducted Power and Modulation Characteristics Plots”). Plots are then provided for each of those channel/ modulation configurations as follows:

2499 MHz, 5.0 MHz BW – 64 QAM 3/4
2593 MHz, 5.0 MHz BW – 64 QAM 3/4
2687 MHz, 5.0 MHz BW – QPSK 1/2
2499 MHz, 10 MHz BW – 64 QAM 2/3
2593 MHz, 10 MHz BW – 64 QAM 3/4
2687 MHz, 10 MHz BW – 16 QAM 3/4

Plots for other data are not shown.

5.5 Occupied and Emission Bandwidth

FCC Rules: 2.1049, 27.53(l)(6)

FCC Requirements: Report Results

Standard: ANSI C63.4-2003
American National Standard for Methods of Measurement of Radio-Noise Emissions from Low-Voltage Electrical and Electronic Equipment in the Range of 9 kHz to 40 GHz.

Test Procedure: The Orthogonal Frequency Division Multiple Access (OFDMA) modulated Time Division Duplex (TDD) RF signal from the test unit is applied to a spectrum analyzer. The bandwidth of the signal is recorded by measuring the modulation bandwidth with the built in measurement function in the spectrum analyzer. The transmitter is enabled in test mode with the attached computer. The RF loss of the attenuators and coax has been measured and is included in the spectrum analyzer offset level.

Measurements are performed at frequencies at the low, mid, and high points of the band and for each of the modulation formats available (QPSK-1/2, QPSK-3/4 and 16 QAM 1/2, 16 QAM 3/4, 64 QAM 1/2, 64 QAM 2/3, and 64QAM 3/4). In addition, measurements were taken for both channel bandwidths (5.0 and 10 MHz).

Test Conditions: **Test Frequencies:** 2499, 2593, 2687 MHz (5.0 and 10 MHz bandwidth)
Temperature: 22°C
Supply Voltage: 120 VAC / 60 Hz nominal to DUT power supply

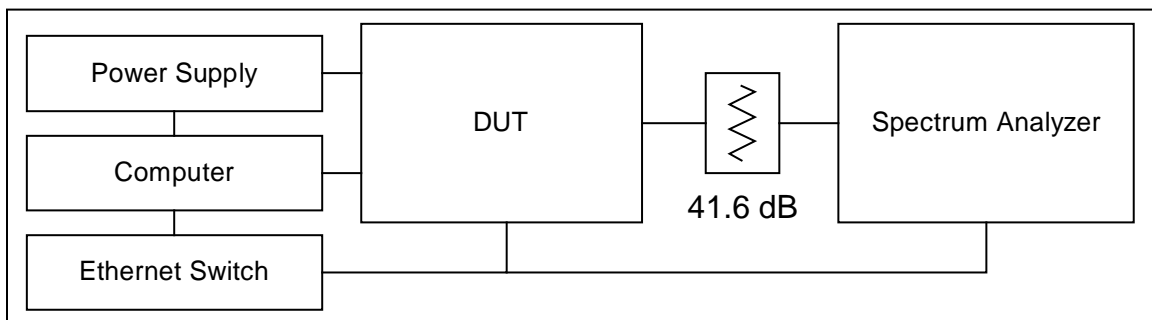

Occupied/Emission Bandwidth Test Setup

5.5.1. Occupied and Emission Bandwidth Test Results Summary

Occupied Bandwidth (MHz) for 99.0% (-20 dB)								
Freq (MHz)	Bandwidth (MHz)	Modulation						
		QPSK 1/2	QPSK 3/4	16 QAM 1/2	16 QAM 3/4	64 QAM 1/2	64 QAM 2/3	64 QAM 3/4
2499	5.5	4.451	4.448	4.445	4.450	4.445	4.446	4.451
2593	5.5	4.448	4.447	4.450	4.449	4.448	4.448	4.444
2687	5.5	4.449	4.449	4.448	4.448	4.447	4.452	4.448
2499	11.0	9.090	9.091	9.091	9.087	9.093	9.091	9.091
2593	11.0	9.090	9.090	9.088	9.092	9.092	9.097	9.094
2687	11.0	9.091	9.091	9.093	9.086	9.095	9.093	9.087

Emission Bandwidth (MHz) for 99.75% (-26 dB)								
Freq (MHz)	Bandwidth (MHz)	Modulation						
		QPSK 1/2	QPSK 3/4	16 QAM 1/2	16 QAM 3/4	64 QAM 1/2	64 QAM 2/3	64 QAM 3/4
2499	5.5	4.723	4.731	4.728	4.733	4.725	4.731	4.726
2593	5.5	4.727	4.728	4.729	4.722	4.722	4.717	4.723
2687	5.5	4.726	4.733	4.727	4.732	4.730	4.723	4.726
2499	11.0	9.453	9.451	9.453	9.449	9.449	9.441	9.441
2593	11.0	9.447	9.456	9.455	9.447	9.451	9.447	9.441
2687	11.0	9.444	9.458	9.459	9.453	9.449	9.449	9.443

5.5.2. Occupied and Emission Bandwidth Spectrum Analyzer Plots

The following are spectrum analyzer plots of the 16 QAM 3/4 data in the preceding tables. The plots for the QPSK 1/2 and 64 QAM 3/4 modulation types are shown in Appendix B (refer to “Occupied/Emission Bandwidth Plots”). The plots for the other modulation types are not shown but are similar

Both Occupied and Emission Bandwidth is shown in the same plot. The 99% Occupied Bandwidth is displayed in large type under “Occupied Bandwidth”, and the -26 x dB Emission Bandwidth is displayed in smaller type to the right of “x dB Bandwidth”.

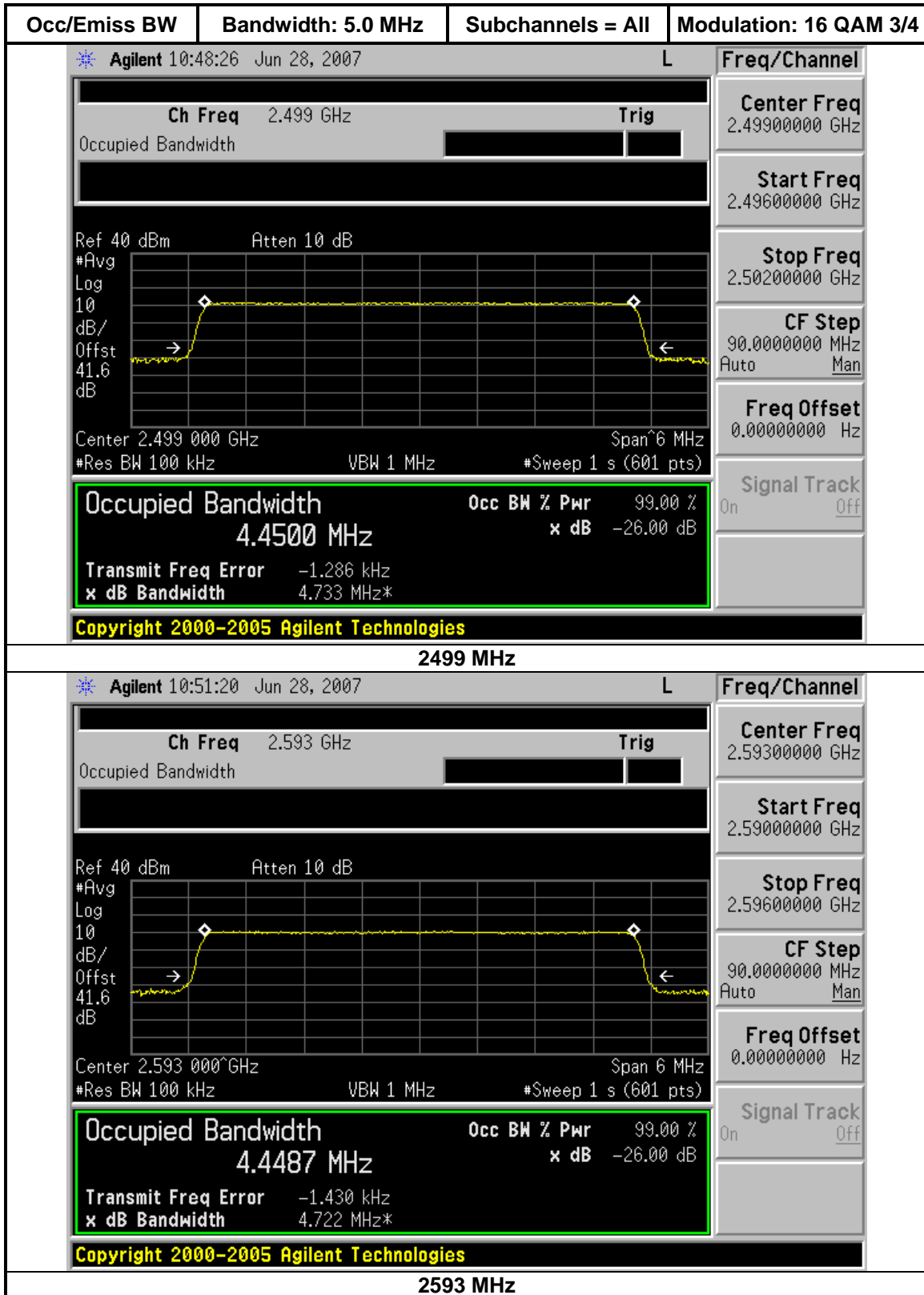

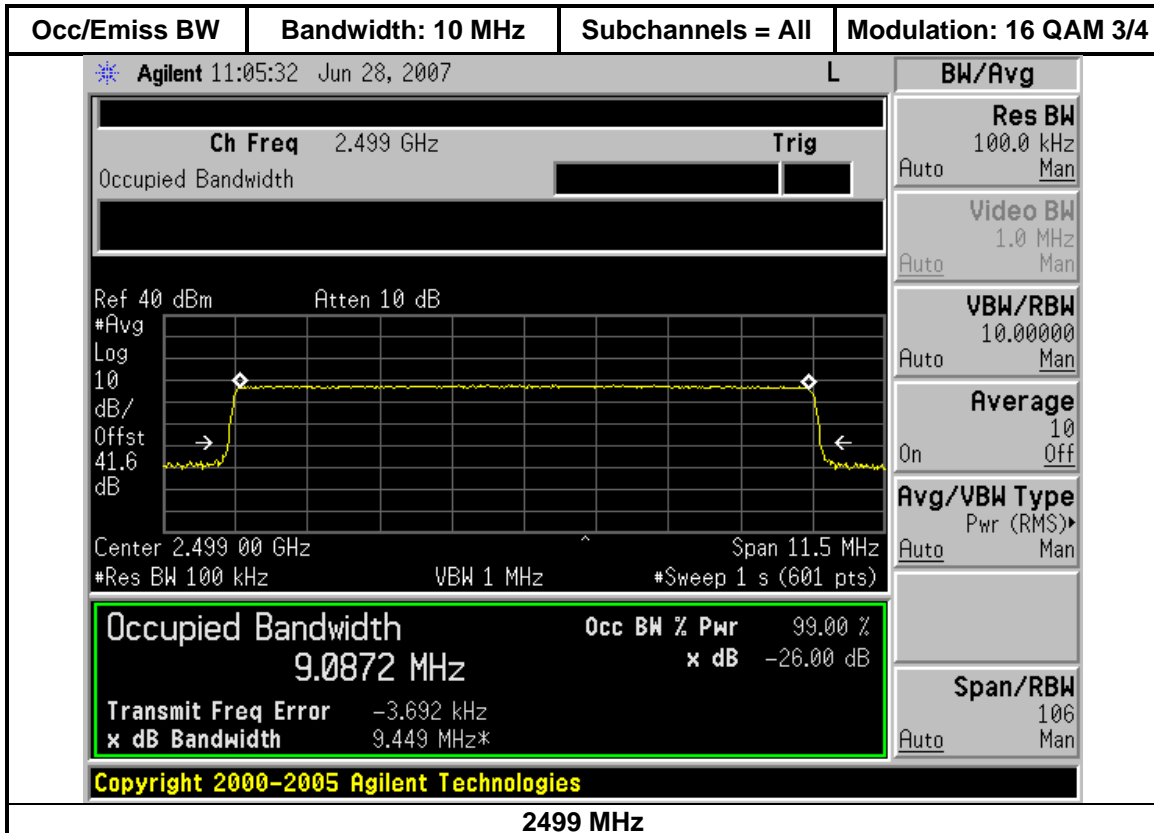
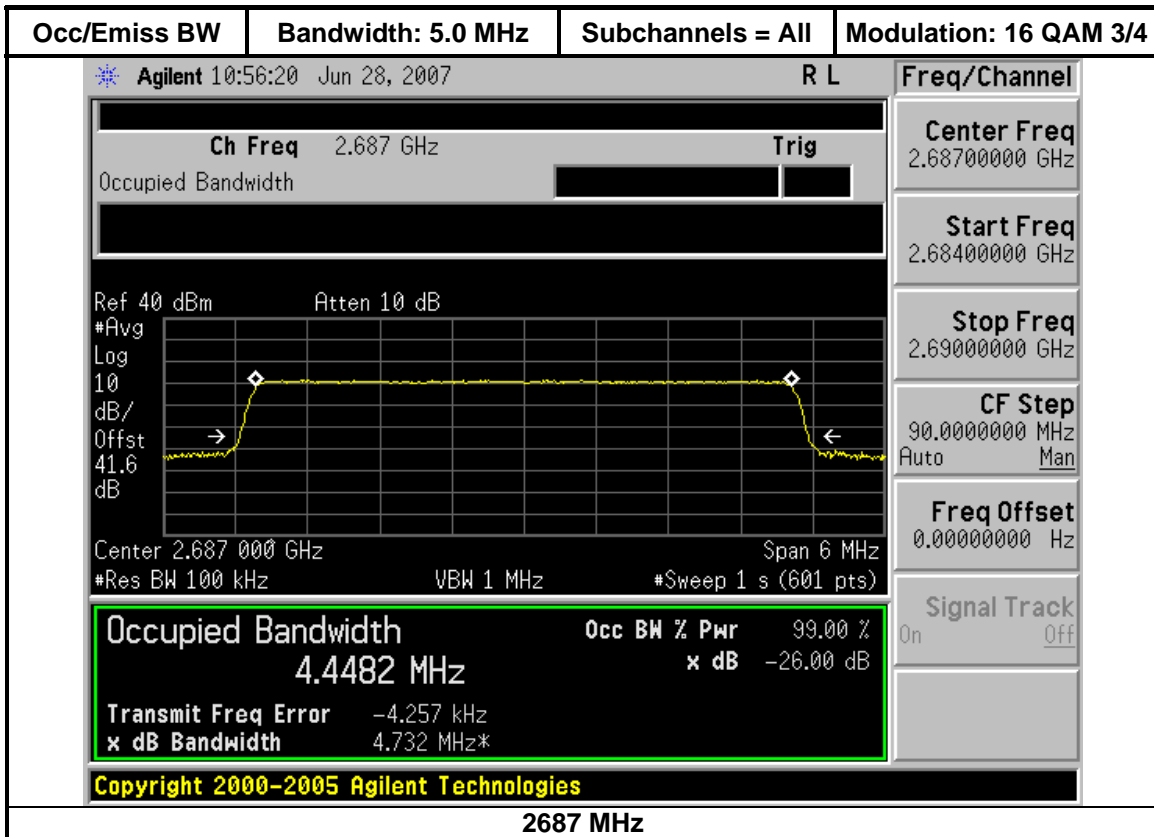

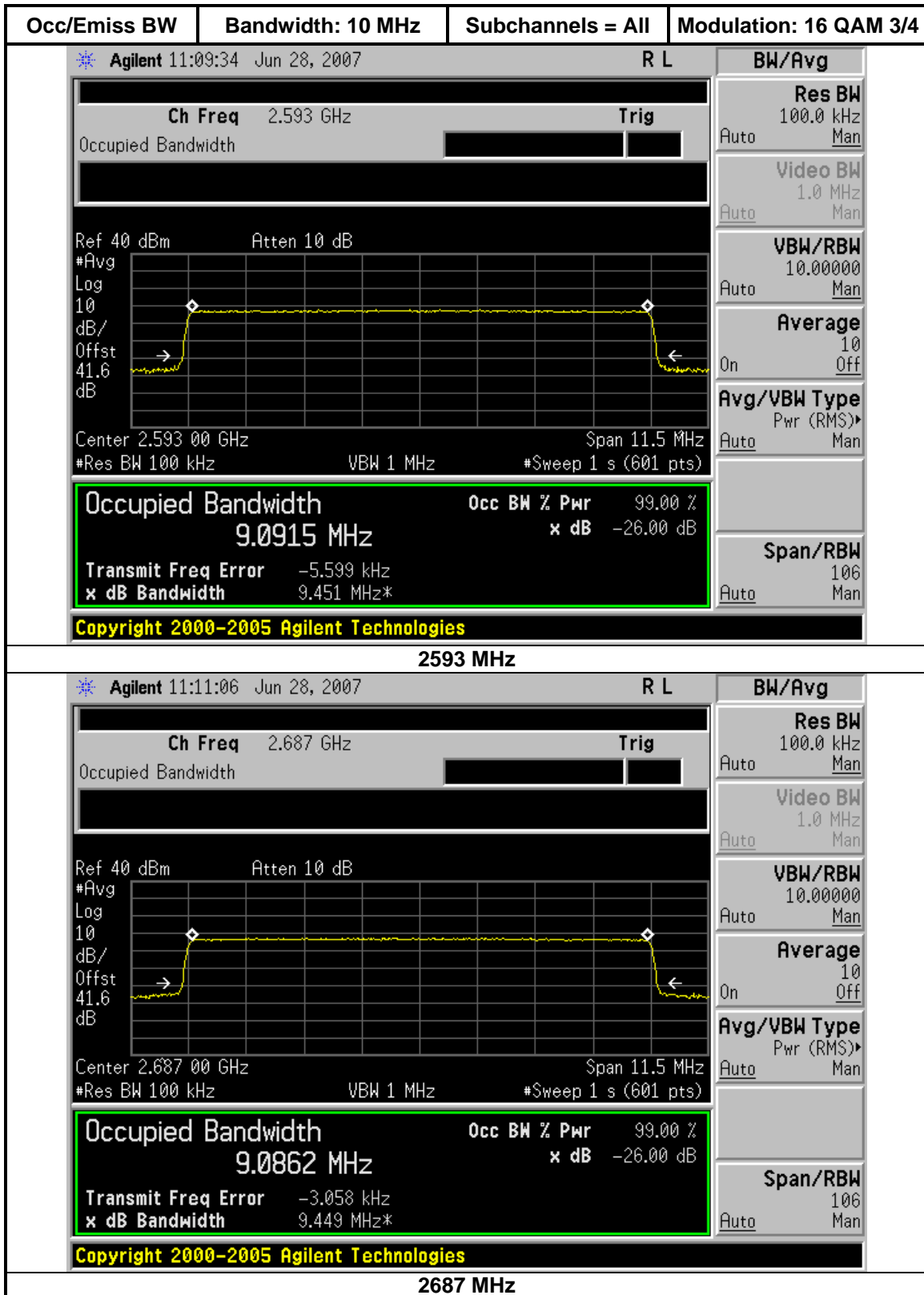

5.6 Transmitter Spurious Emissions

FCC Rules: 2.1051, 2.1049, 2.1057

Standard: TIA-603-C
TIA Standard, Land Mobile FM or PM Communications
Equipment, Measurement and Performance Standards

Test Procedure: The Orthogonal Frequency Division Multiple Access (OFDMA) modulated Time Division Duplex (TDD) RF signal from the test unit is applied to a spectrum analyzer thru an attenuator and coax, or, for harmonic measurements, through an attenuator, high pass filter and coax that was calibrated for RF loss at each harmonic frequency being tested. The transmission is recorded from 9 kHz to 26.5 GHz in multiple plots. The transmitter is enabled in test mode with the attached computer. The RF loss of the attenuator and coax is included in the spectrum analyzer offset level. Measurements are performed at frequencies across the band and both channel bandwidths (5.0 MHz and 10 MHz). A modulation level of 16 QAM 3/4 was used for all measurements with all subchannels enabled and the maximum of 8 time slots were selected.

One data plot from each channel bandwidth is included for measurements below the BRS/EBS frequency band (below 2.48 GHz). All other channels measured had similar-looking spectral plots. For tests above the BRS/EBS frequency (2.7-26.5 GHz), plots for all channels are included. For harmonic tests, plots are shown for the second and third harmonic of all test channels.

Test Conditions: **Channels:** 2499, 2593, and 2687 MHz (5.0 and 10 MHz bandwidth)
Temperature: 22°C
Supply Voltage: 120 VAC / 60 Hz nominal to the DUT power supply

Test Results: Passes conducted emissions from 9 kHz to 26.86 MHz. All spurious and harmonic emissions are more than 20 dB below the -13 dBm limit.

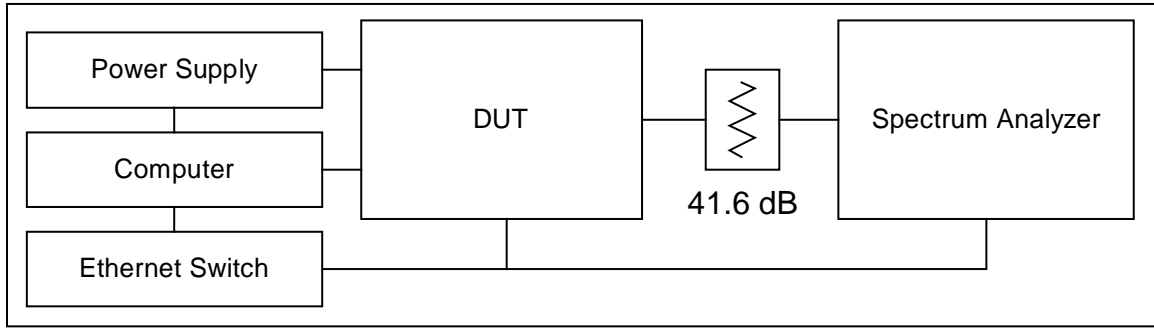

Spurious Emissions Test Setup

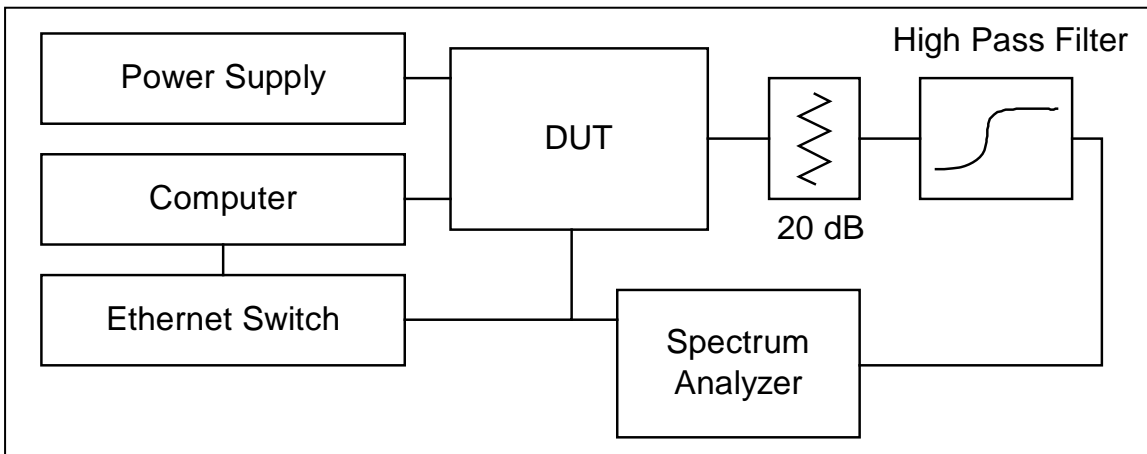

Harmonic Emissions Test Setup

5.6.1. Transmitter Spurious Emissions Plots

For frequencies below 2.48 GHz, plots for only the 2593 MHz (5.0 and 10 MHz bandwidth) channels are shown on the pages which follow. The plots for the other channels are similar and are located in Appendix B (see “Transmit Spurious Emissions”). For frequencies above 2.48 GHz, plots for all test channels are shown.

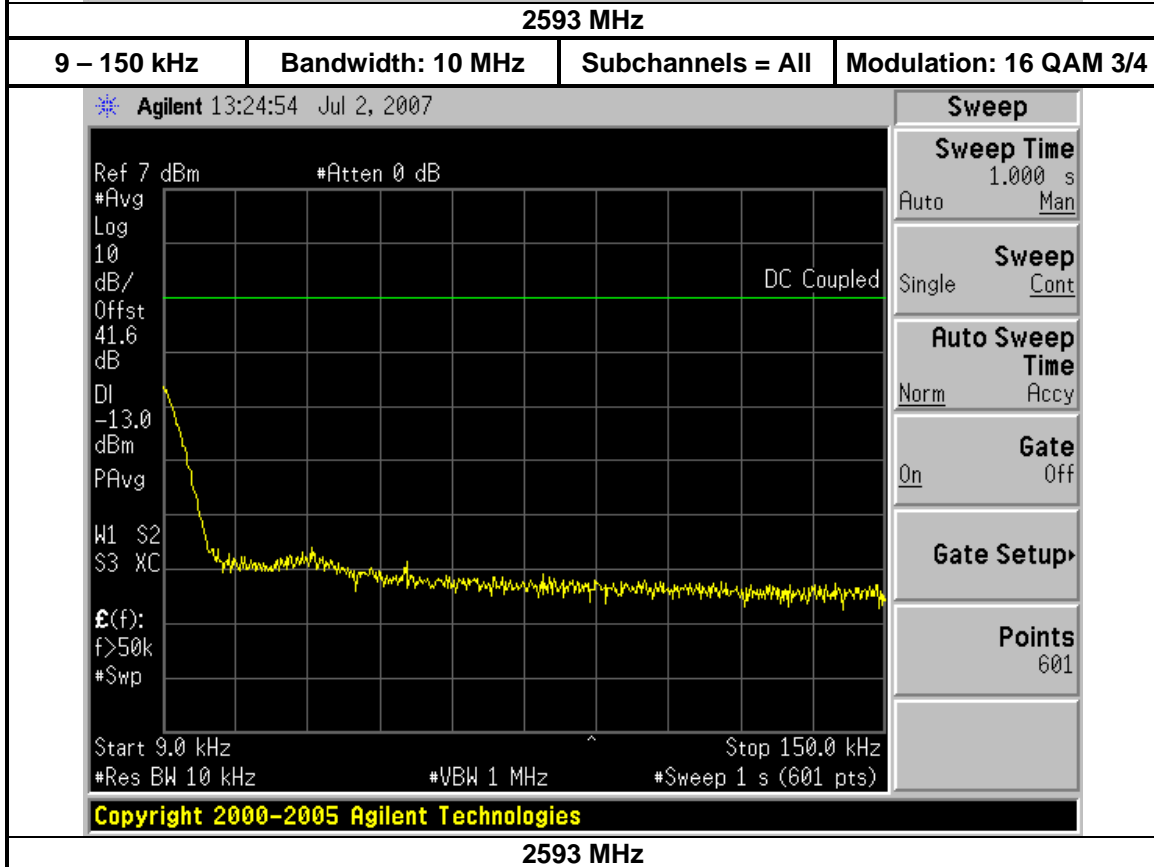
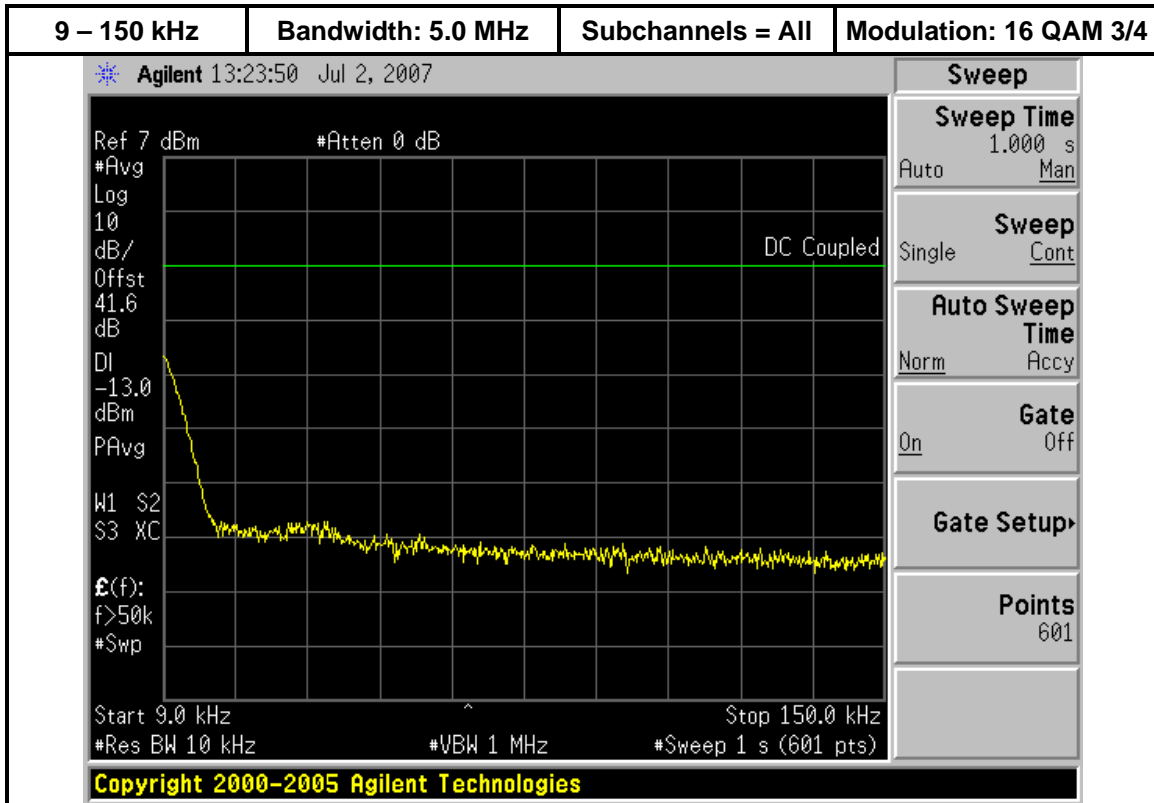

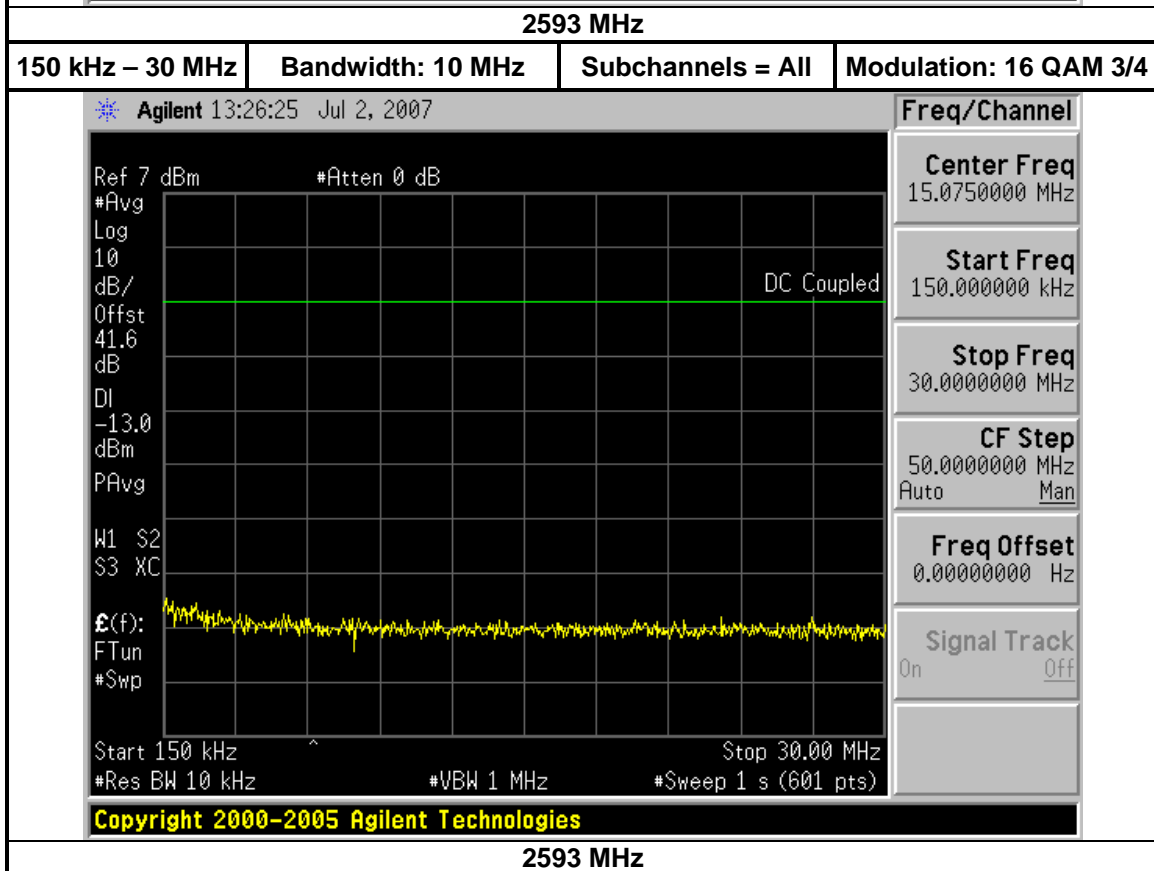
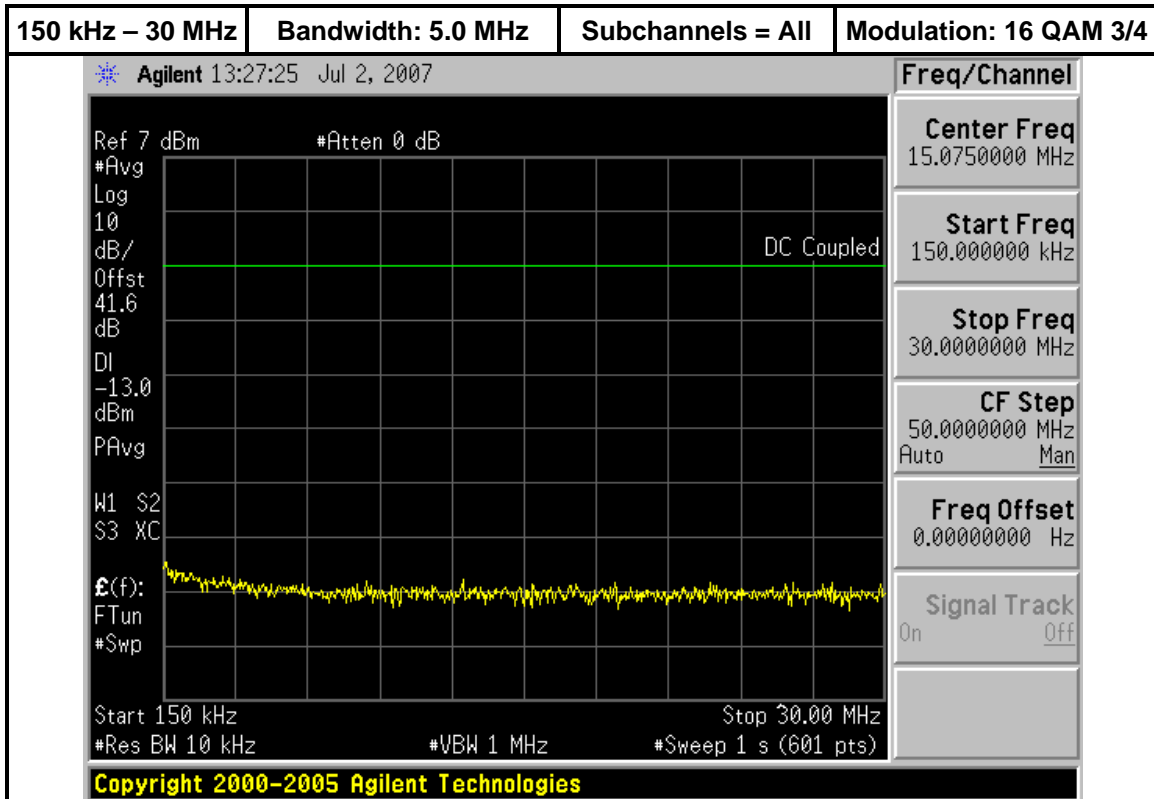

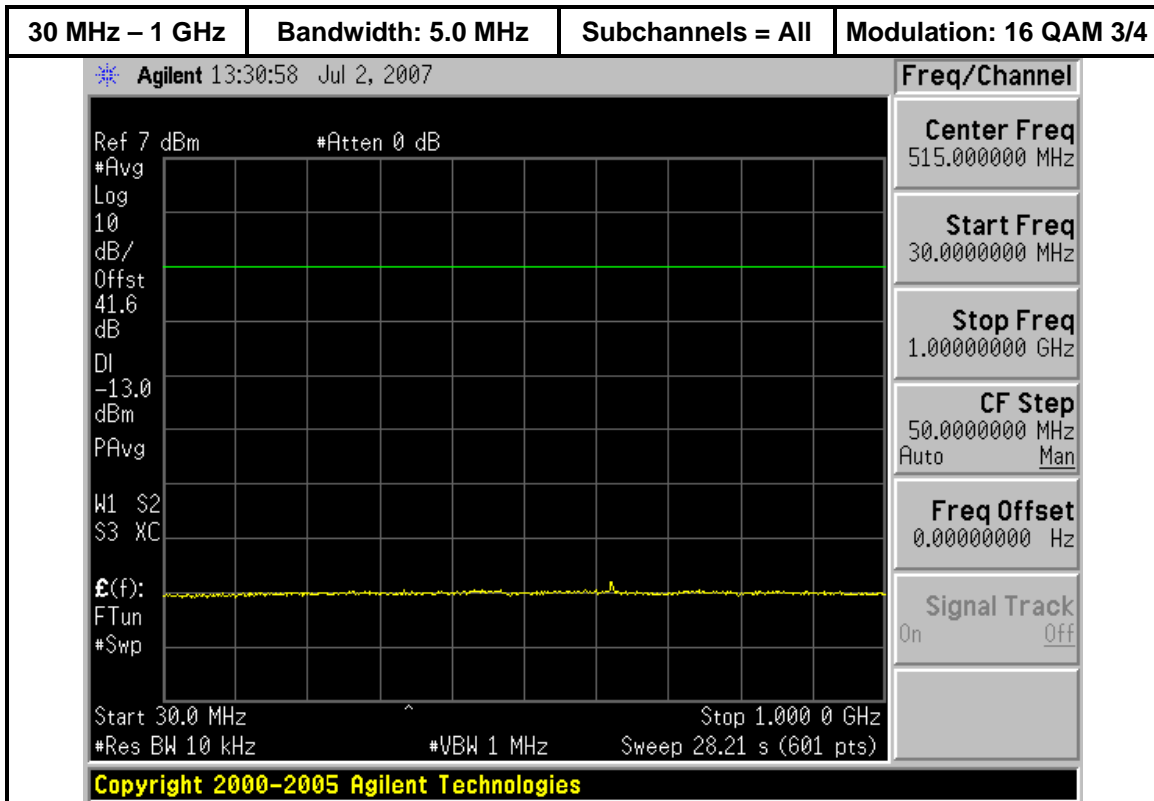

2593 MHz

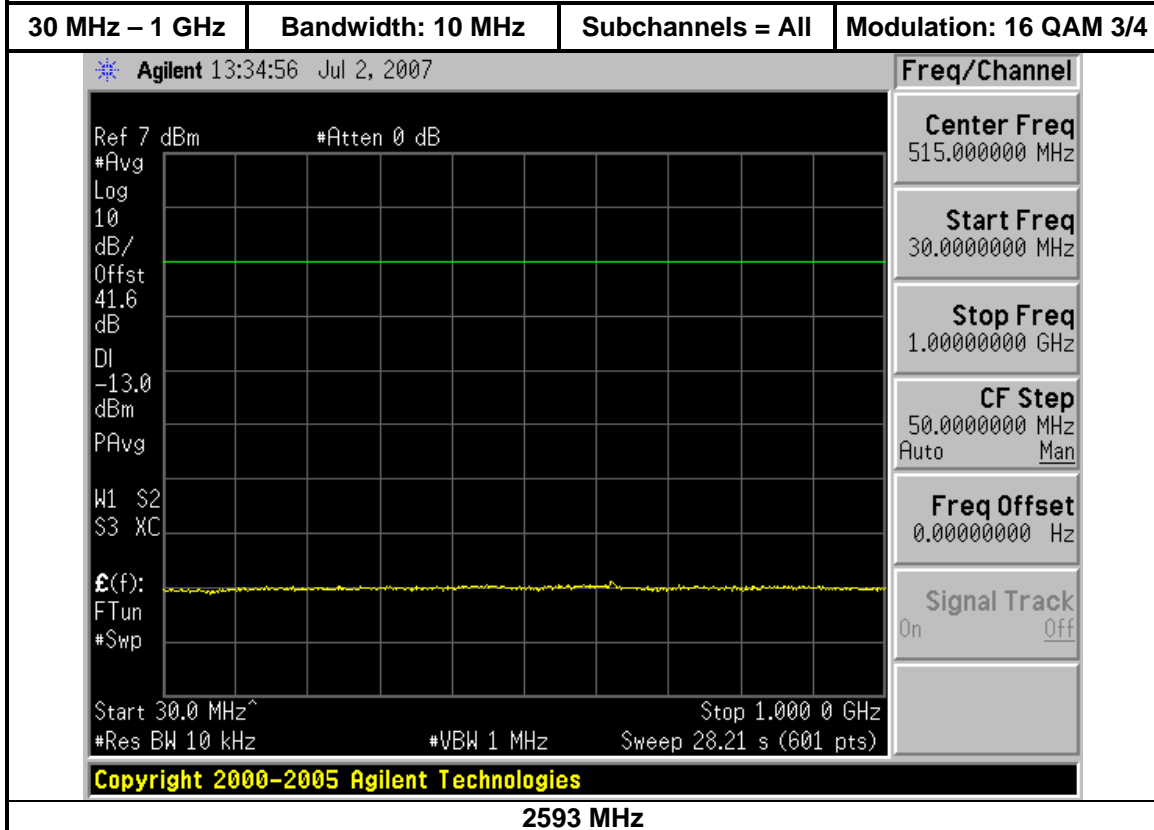

2593 MHz

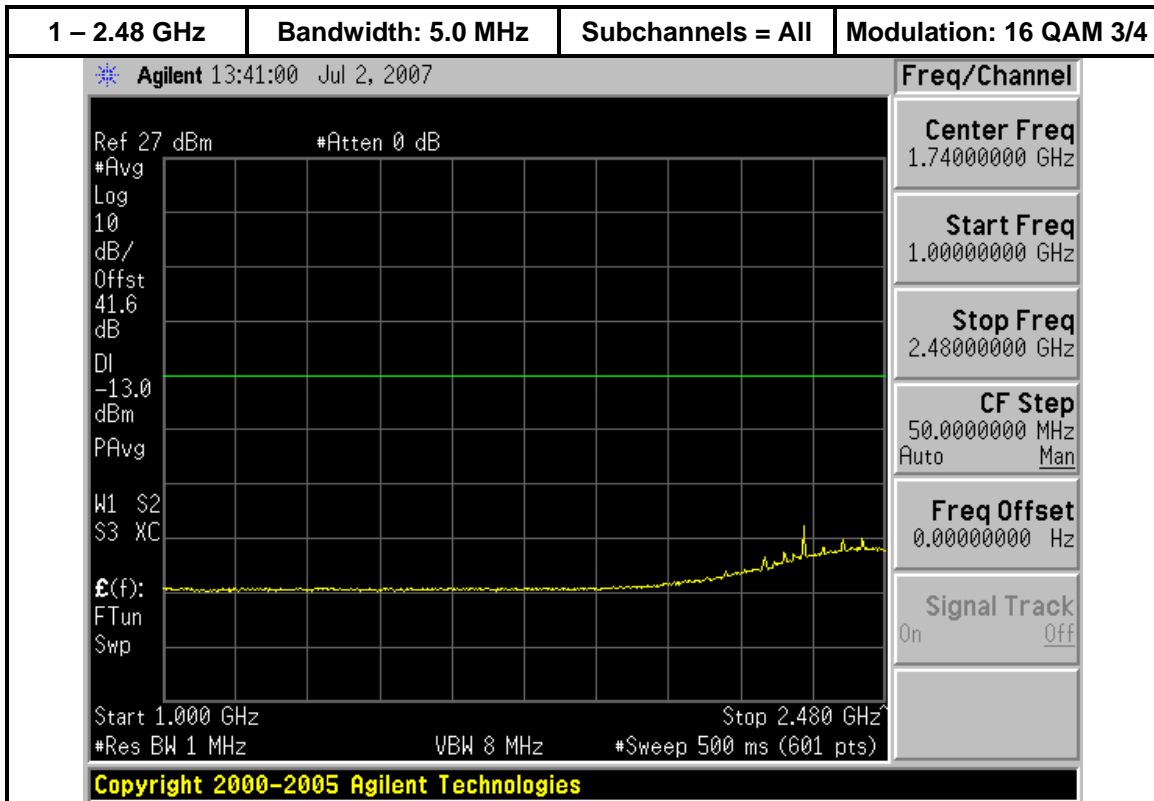

2593 MHz

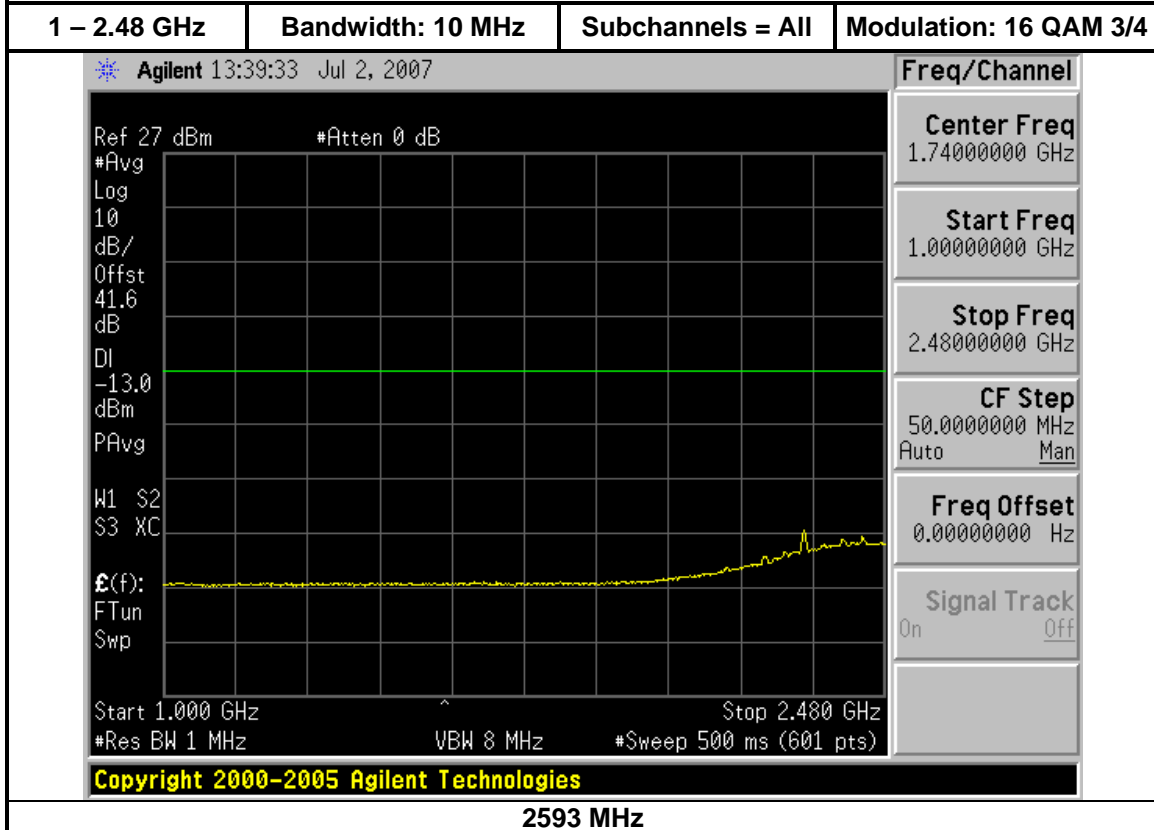

2593 MHz

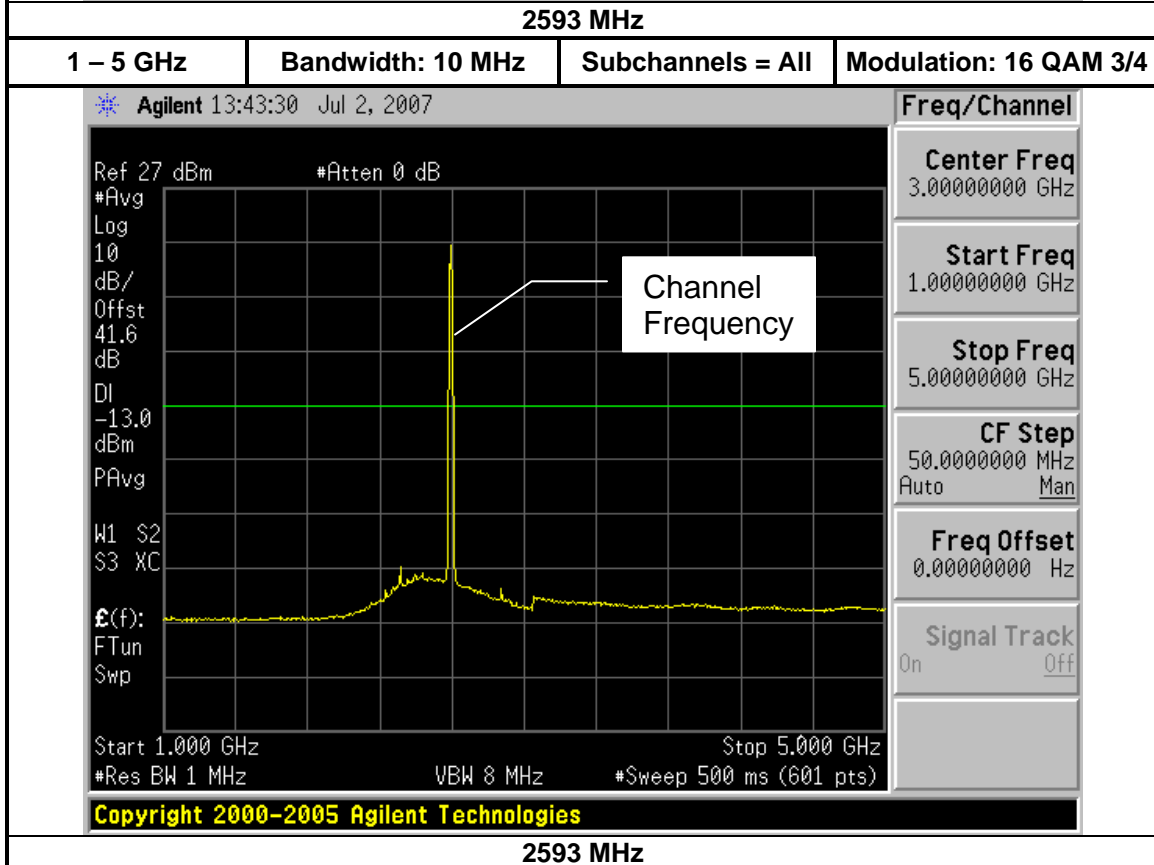
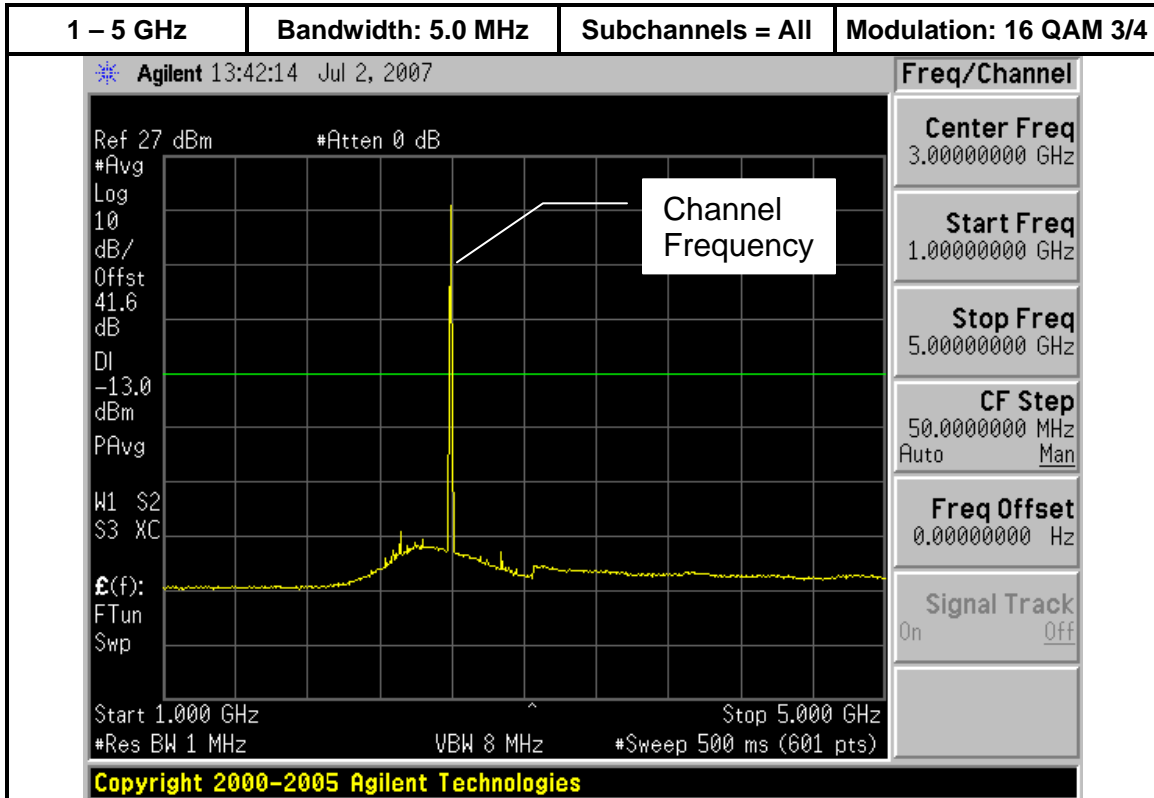

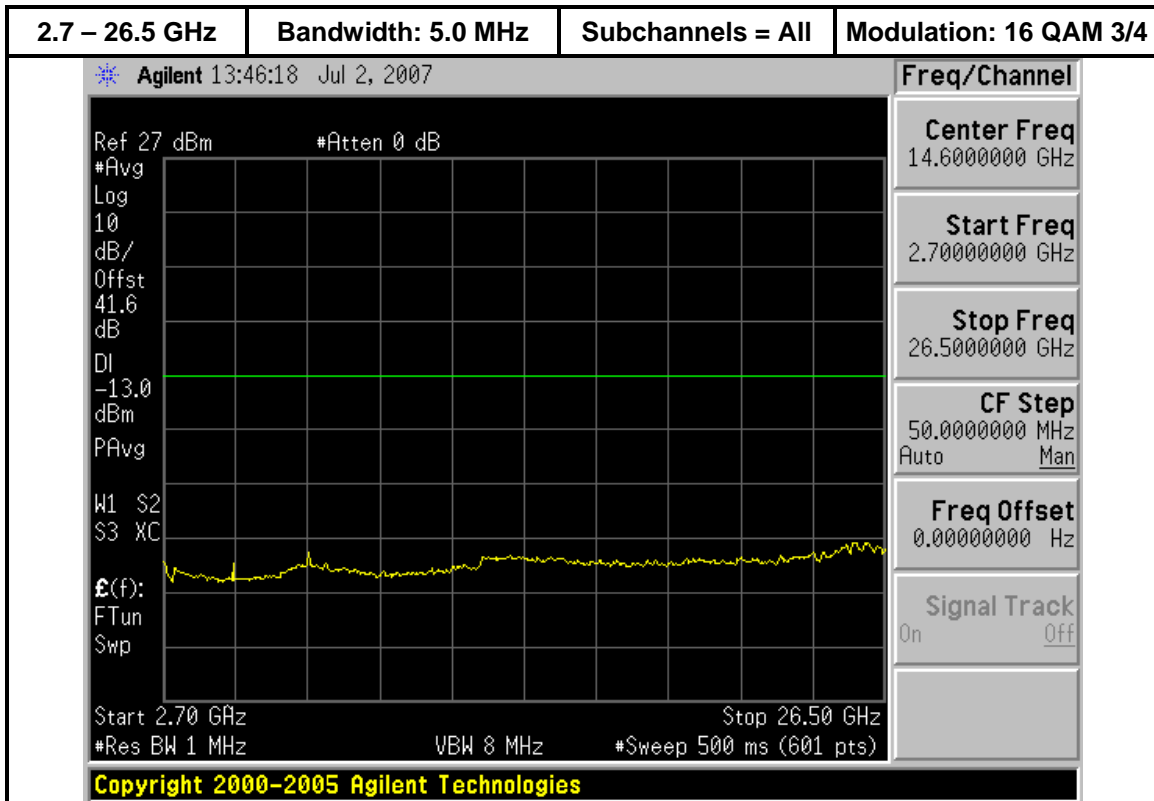

2499 MHz

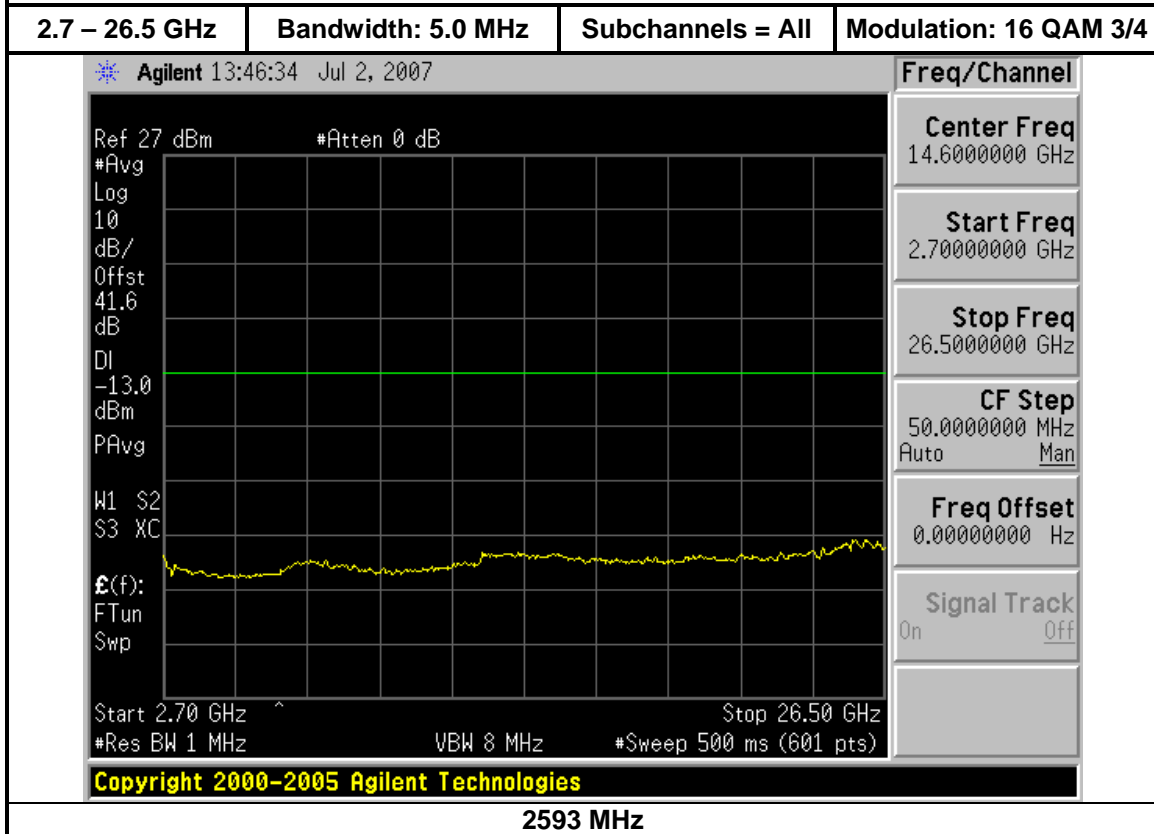

2593 MHz

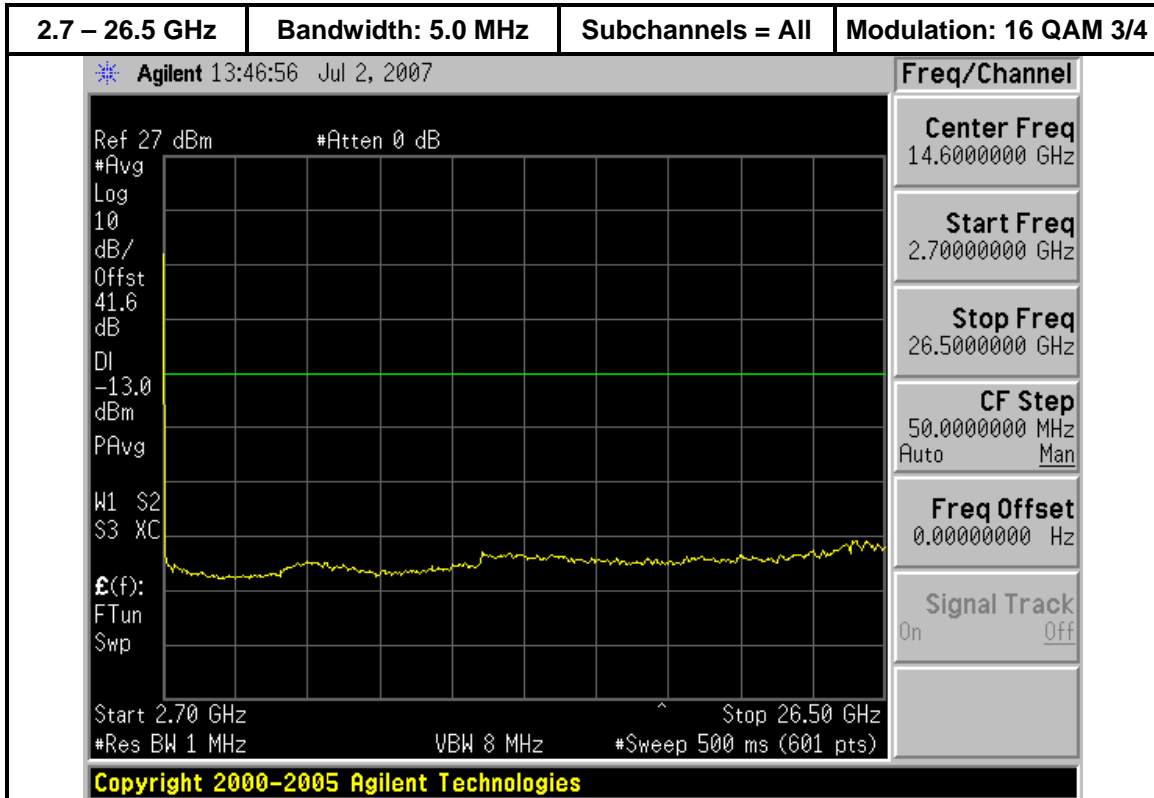

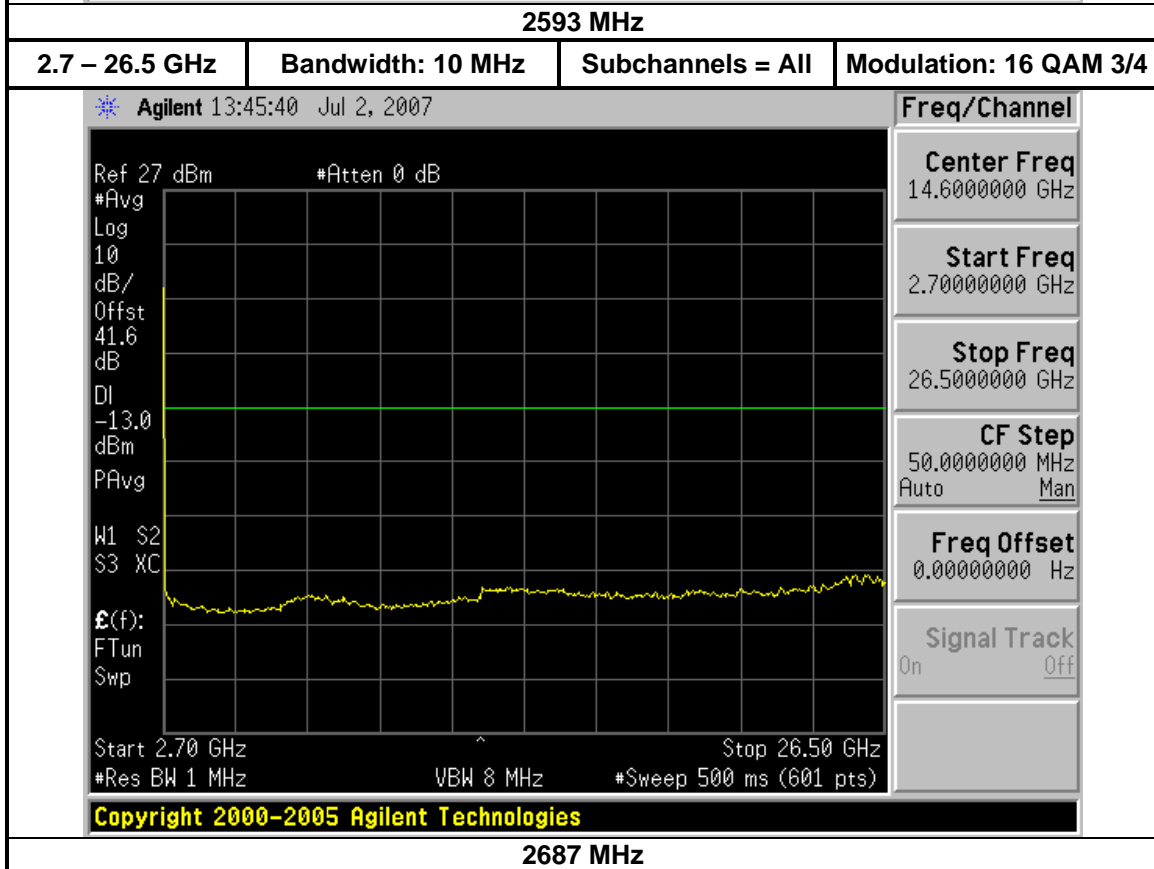
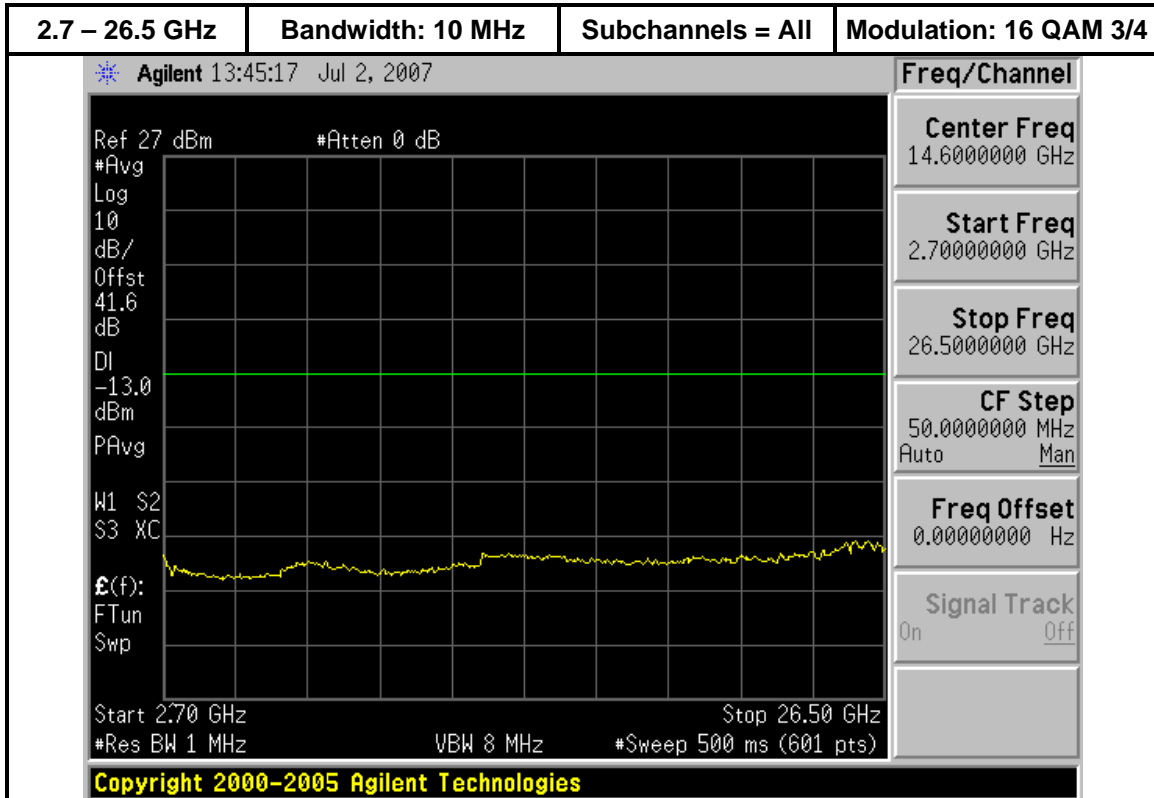

5.6.2. Second Harmonic Emissions Plots

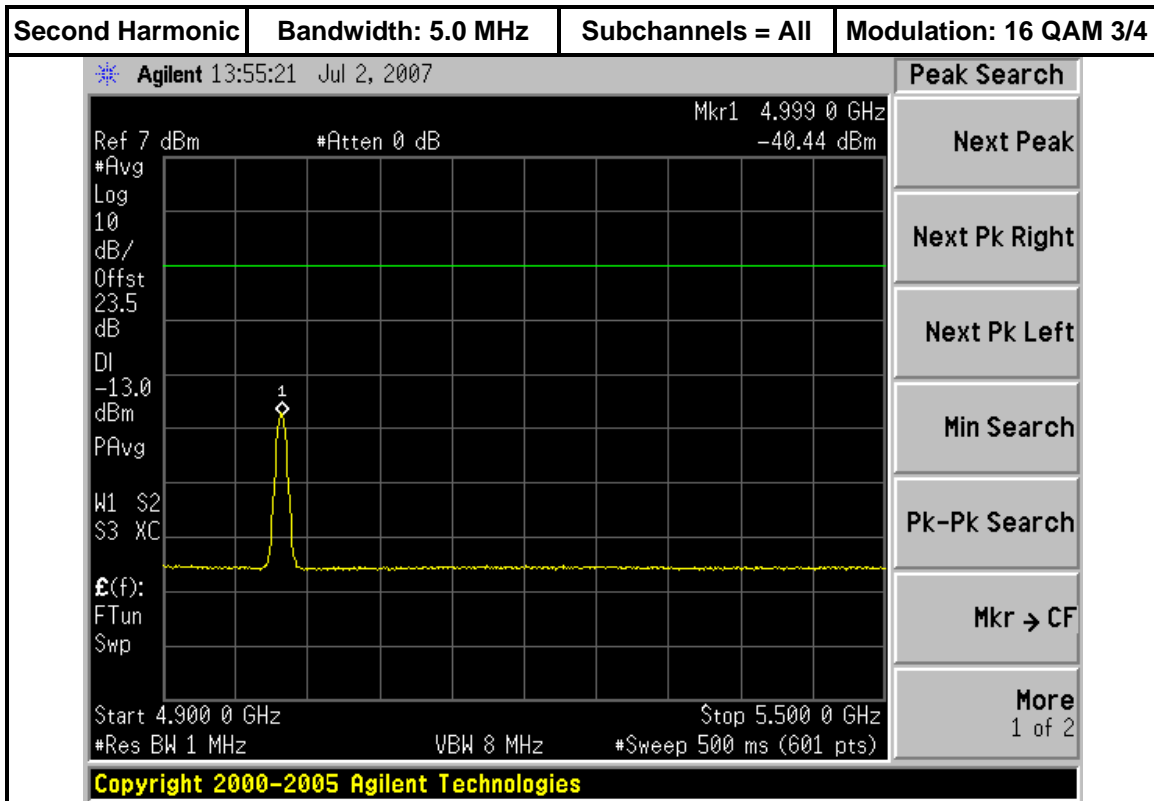

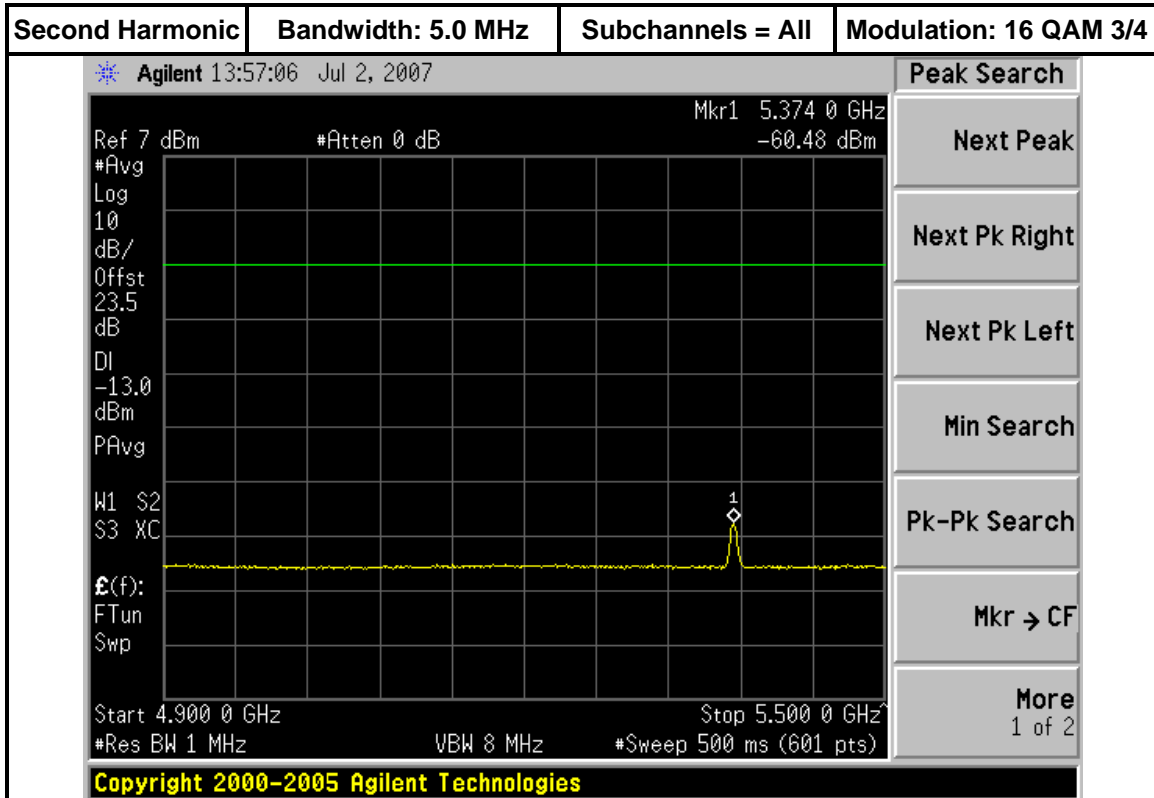

2687 MHz

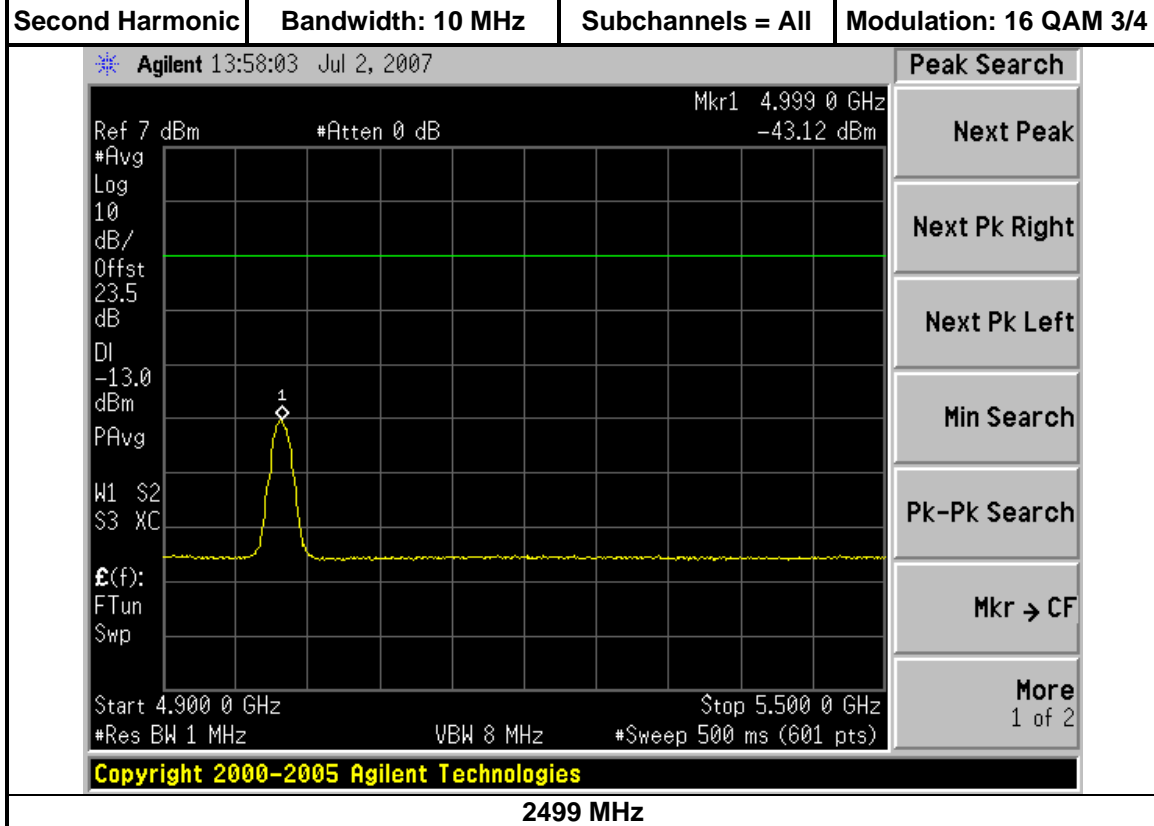

2499 MHz

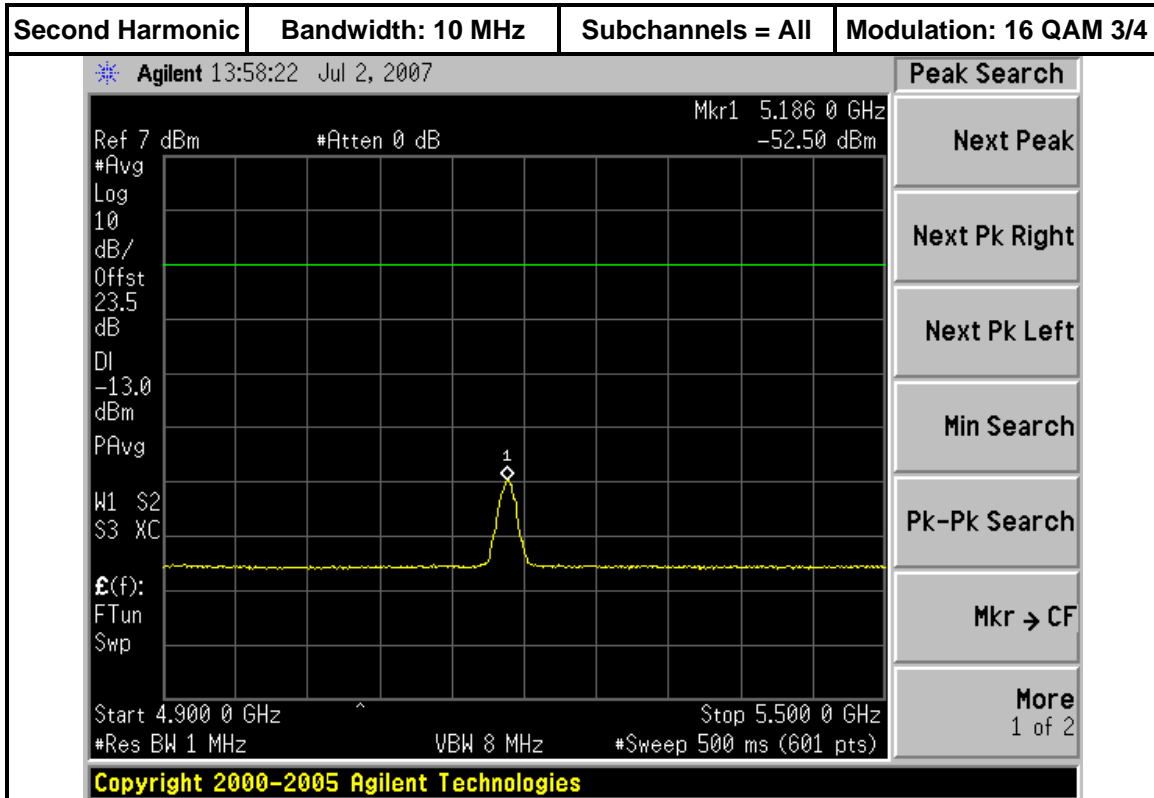

2593 MHz

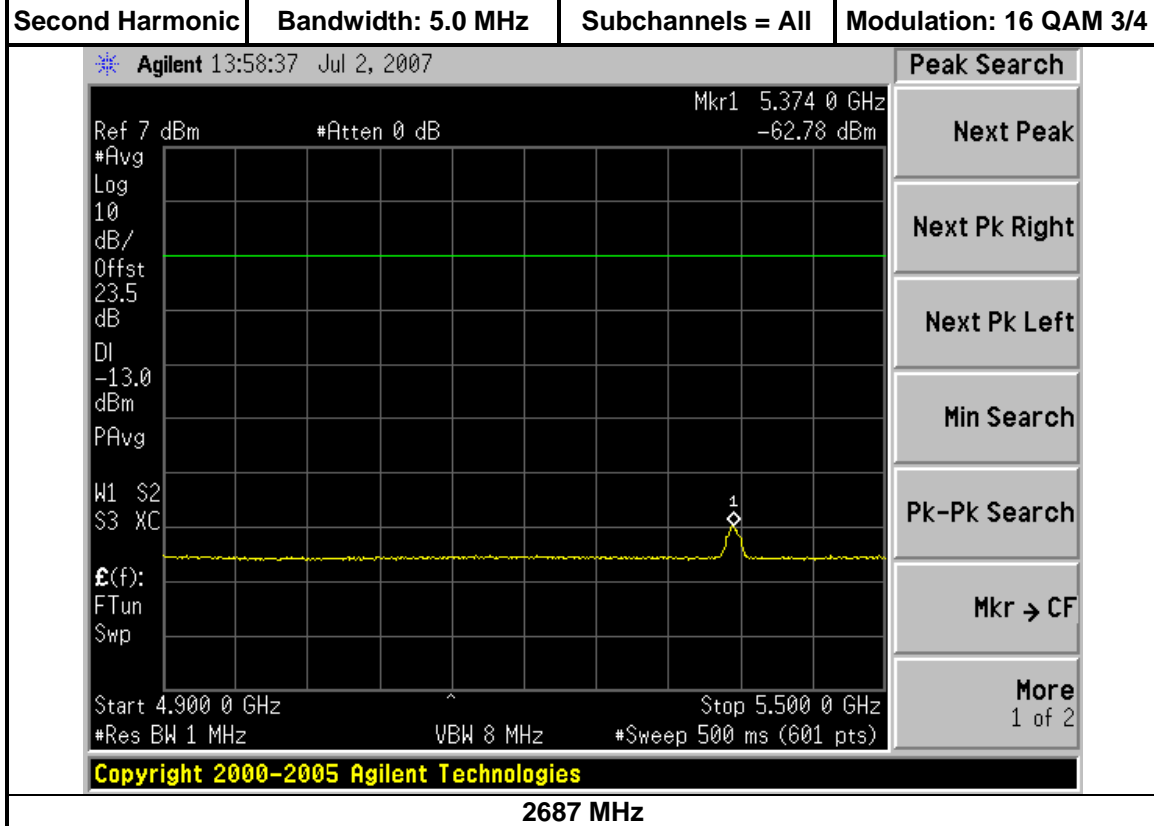

2687 MHz

5.6.3. Harmonic 3 Emissions Plots

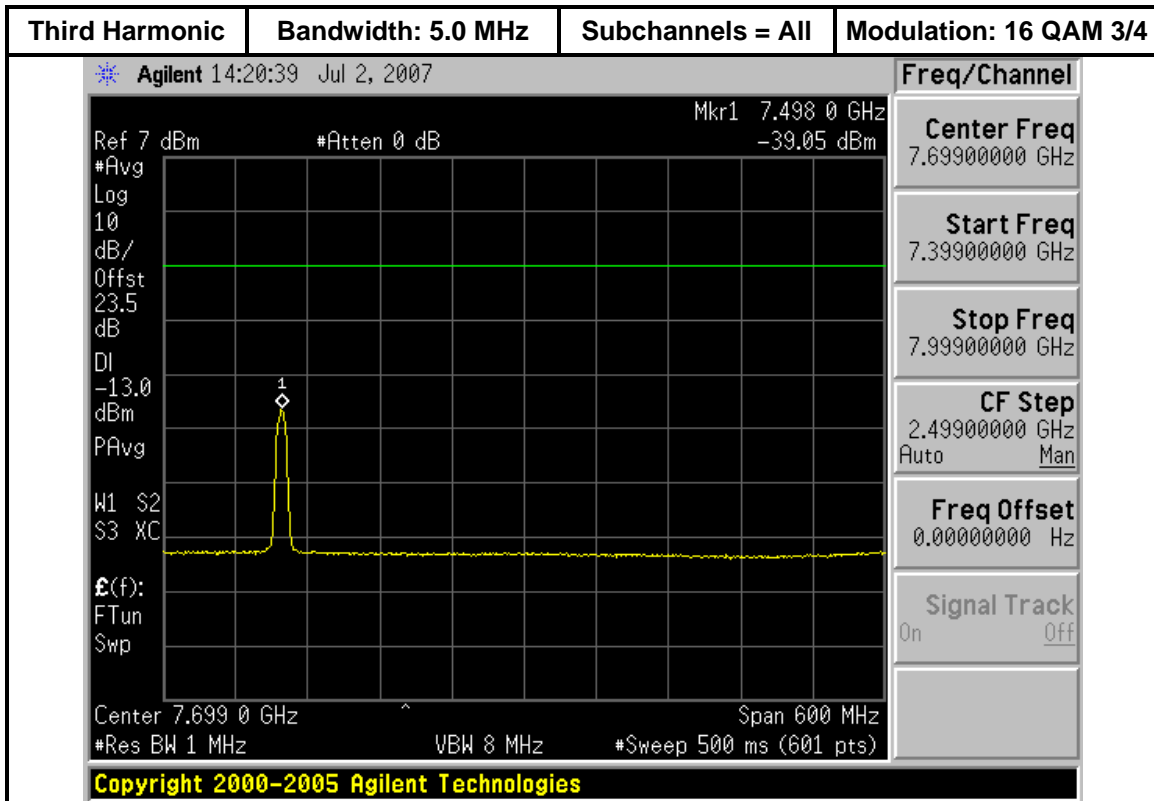

2499 MHz

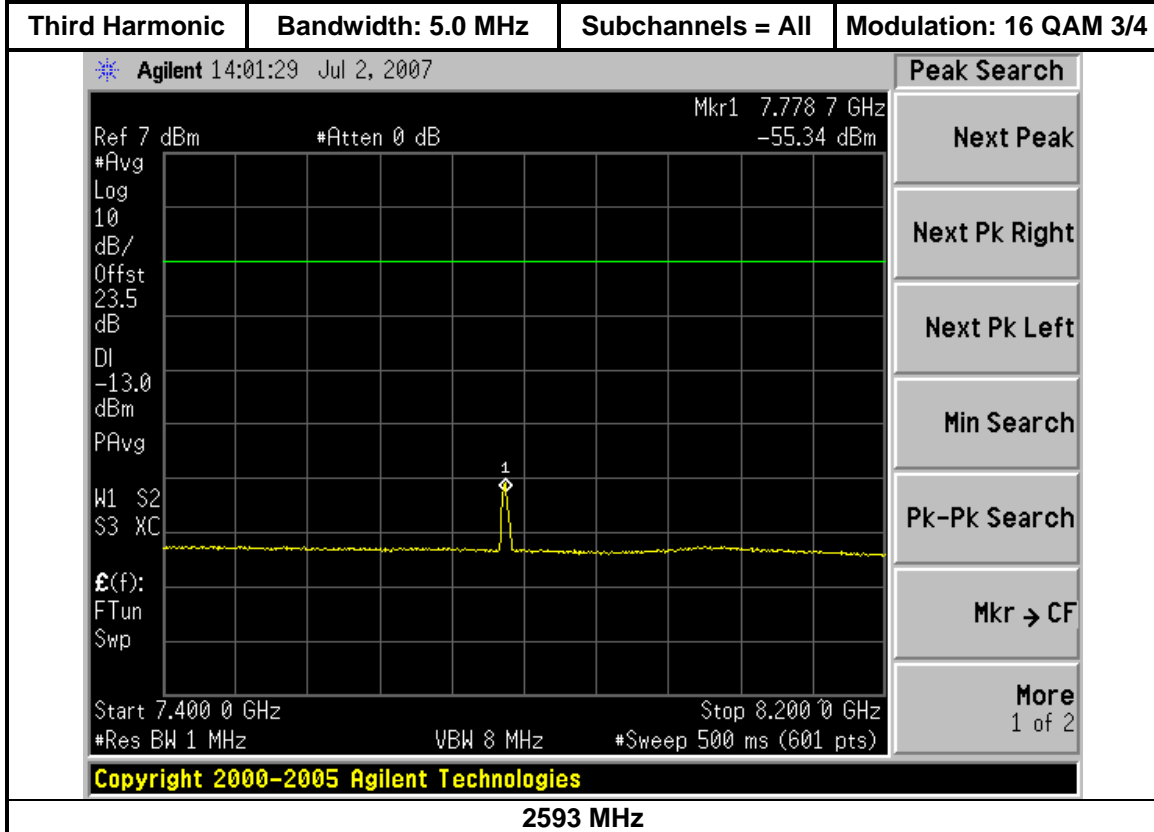

2593 MHz

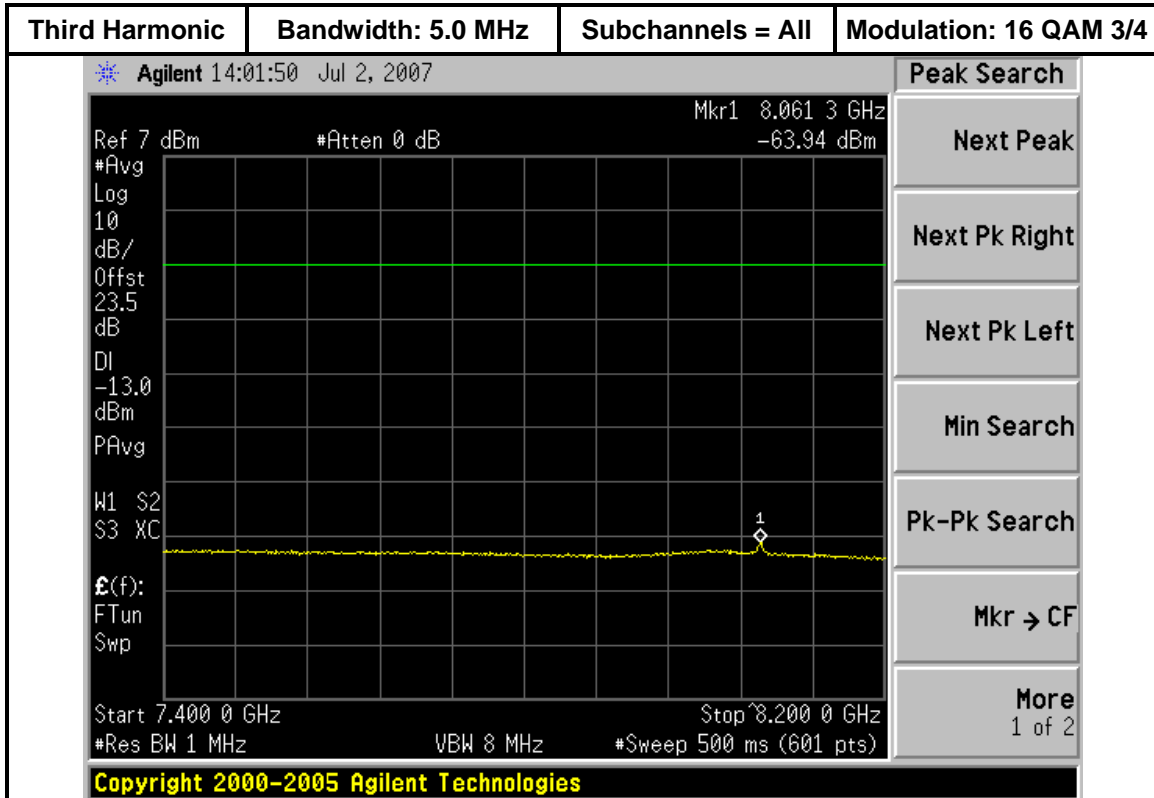

2687 MHz

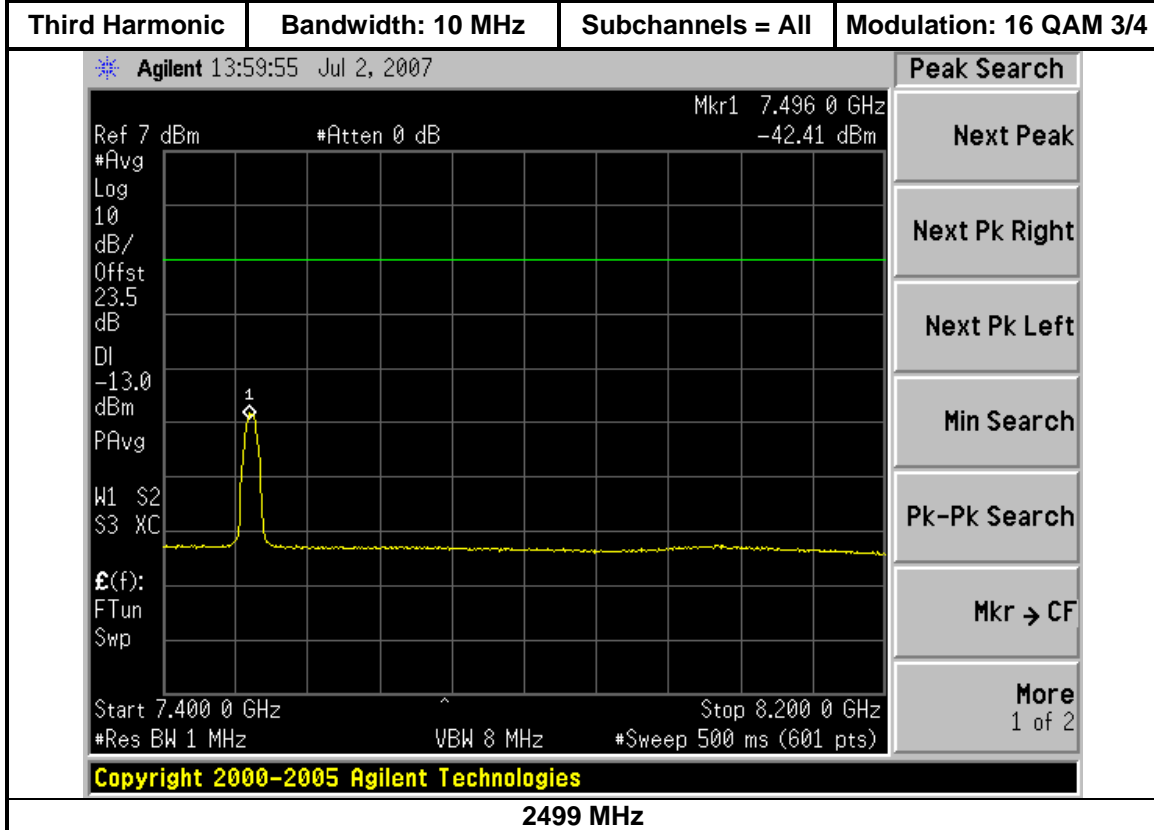

2499 MHz

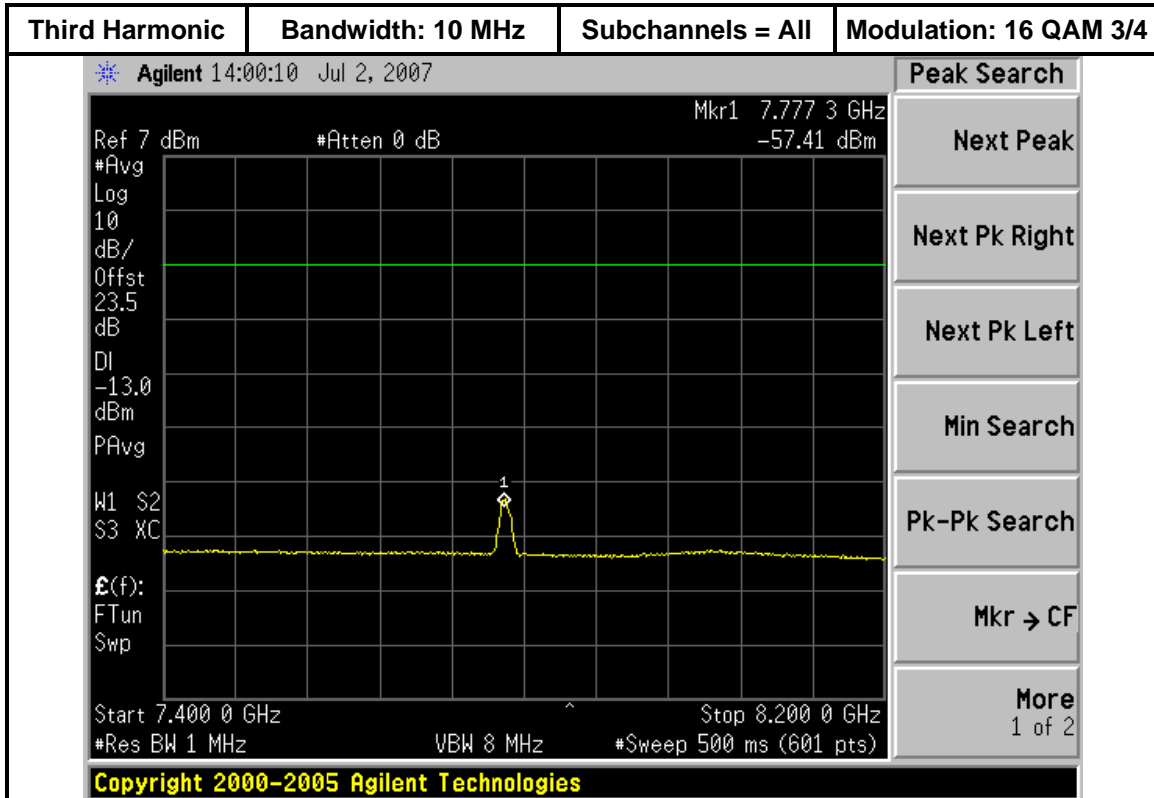

2593 MHz

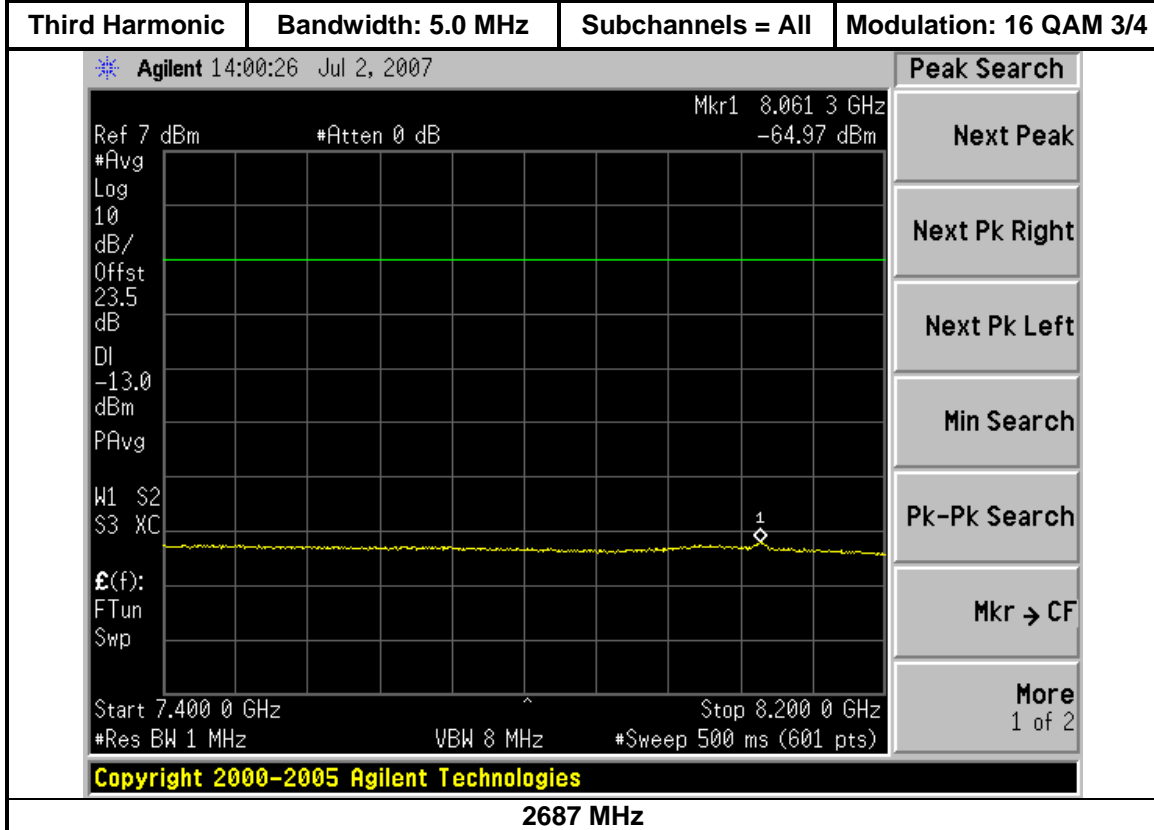

2687 MHz

5.7 Field Strength of Spurious Radiation

FCC Rules: 2.1053, 2.1049, 2.1057

FCC Requirement: Emissions to be $43+10*\log(P)$ below the channel power or an absolute level of -13 dBm

Frequency Range = 30 MHz to 26.86 GHz

Case Radiation Attenuation = $43+10\log P = -13$ dBm maximum

Standards: TIA-603-C
TIA Standard, Land Mobile FM or PM Communications
Equipment, Measurement and Performance Standards

ANSI C63.4-2001 clause 5.4 Radiated Emissions Tests.
American National Standard for Methods of Measurement of
Radio-Noise Emissions from Low-Voltage Electrical and
Electronic Equipment in the Range of 9 kHz to 40 GHz.

Test Procedure: The field strength of spurious radiation was measured at an open area test site with the applicable measurement antennas, low noise amplifiers, and spectrum analyzers. This test was performed with the transmitter/receiver port terminated with its integral antenna(s). Measurements were performed by TUV America located in Taylors Falls, Minnesota on June 11th, 12th, 14th, 15th, 18th, and 22nd, 2007. Spurious signals were maximized for peak level by rotation of the test unit and elevation of the measurement antenna. Verification of compliance to the emissions limit was accomplished by antenna substitution as detailed in the TIA-603-C specification. TUV America-Product Service FCC registration number: 90983

Test Conditions: **Frequency:** 2499, 2593, 2687 MHz
Channel bandwidths: 5.0 MHz and 10 MHz
Temperature: 25°C
Supply Voltage: 120 VAC / 60 Hz nominal to DUT power supply

Test Results: Passes Field Strength of Spurious Radiation
Refer to attached TUV Test Report: 5B EMC Test Report.pdf

5.8 Frequency Stability Test

FCC Rules: 2.1055, 27.53(1)(4), 27.53(1)(6), 27.54

FCC Requirement: The frequency stability shall be sufficient to ensure that the fundamental emissions stay within the authorized bands of operation.

Standard: TIA-603-C

Test Procedure: The frequency stability of the Motorola, Inc. RDMi-25100 WiMax fundamental oscillator is derived from the on board 40 MHz TCXO. Since each radio channel operating frequency is synthesized and referenced to the 40 MHz TCXO, only one channel will be reported for frequency stability as all channels will have the same frequency characteristics.

The procedure used for “Modulation Characteristics”, section 5.4 of this document was repeated to show compliance to the Frequency Stability requirements for the WiMax transmitter of the RDMi-25100 product.

Test Set-Up:

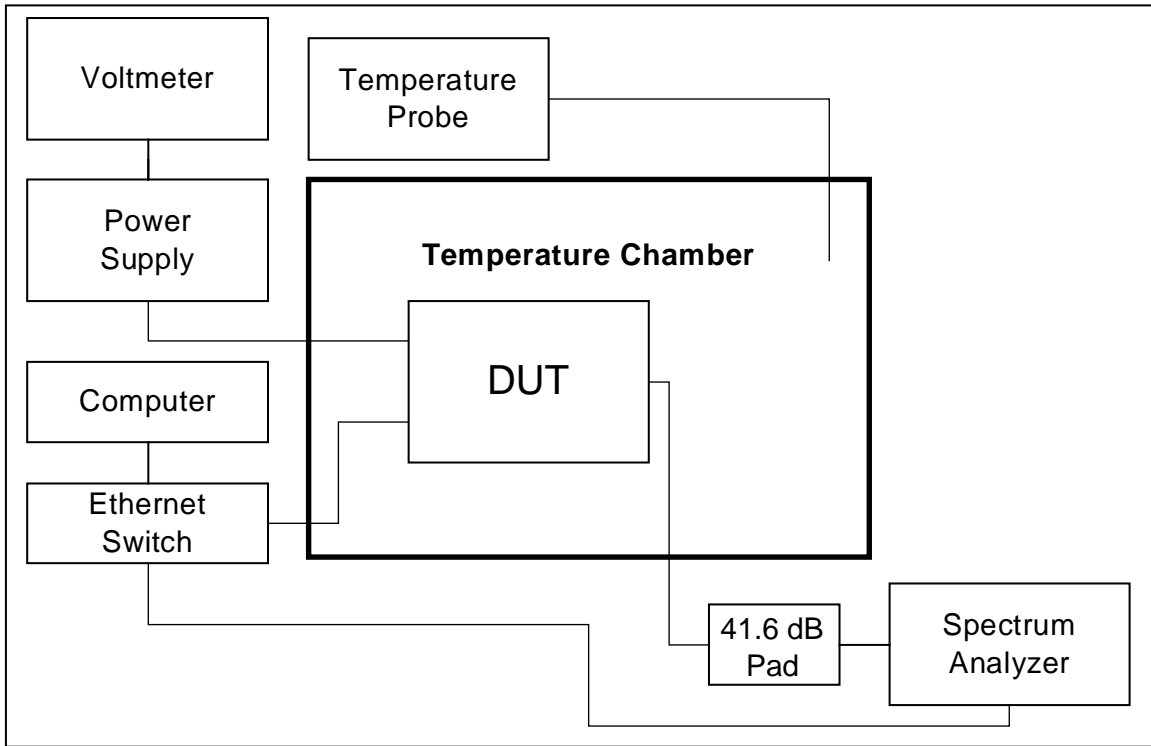

Frequency Stability Test Setup

5.8.1. Temperature Variation Test Results

Test Conditions: **Frequency:** 2593 MHz (5.0 and 10 MHz channel bandwidths)
Supply Voltage: 120 VAC / 60 Hz nominal to DUT power supply
Temperature: -30° C to +50° C in 10° C increments

Test Results: Pass Temperature Variation
 The tables below summarize the information from the plots contained in this section and in the Appendix.

Frequency Stability Emissions 2.593 GHz 5.0 MHz Bandwidth							
Temp °C	a/A	b	B	Margin to -13 dBm limit	g	G	Margin to -25 dBm limit
-30	Pass	-14.18	-13.70	.70	-31.04	-31.36	6.04
-20	Pass	-15.26	-15.07	2.07	-31.99	-32.52	6.99
-10	Pass	-16.69	-17.19	3.69	-32.35	-33.21	7.35
0	Pass	-13.15	-13.48	.15	-30.83	-30.76	5.76
10	Pass	-14.74	-15.80	1.74	-32.18	-33.23	7.18
20	Pass	-16.41	-16.82	3.41	-33.58	-34.04	8.58
30	Pass	-13.71	-13.43	.43	-31.99	-31.85	6.85
40	Pass	-15.20	-14.92	1.92	-32.84	-33.46	7.84
50	Pass	-15.99	-17.01	2.99	-34.37	-34.75	9.37

Frequency Stability Emissions 2.593 GHz 10.0 MHz Bandwidth							
Temp °C	a/A	b	B	Margin to -13 dBm limit	g	G	Margin to -25 dBm limit
-30	Pass	-19.00	-18.38	5.38	-25.52	-25.92	.52
-20	Pass	-19.58	-20.71	6.58	-27.22	-27.48	2.22
-10	Pass	-20.80	-21.41	7.80	-28.46	-28.00	3.00
0	Pass	-19.05	-18.38	5.38	-25.56	-26.95	.56
10	Pass	-19.92	-20.63	6.92	-25.91	-25.99	.91
20	Pass	-17.49	-17.33	4.33	-25.09	-25.02	.02
30	Pass	-18.69	-19.29	5.69	-25.57	-25.75	.57
40	Pass	-17.81	-18.37	4.81	-25.15	-26.05	.15
50	Pass	-15.71	-16.11	2.71	-25.03	-25.10	.03

5.8.2. Temperature Variation Spectrum Analyzer Plots

Spectrum analyzer plots of the 5.0 MHz bandwidth measurements follow. The plots for the 10 MHz bandwidth channels are similar and are located in the Appendix.

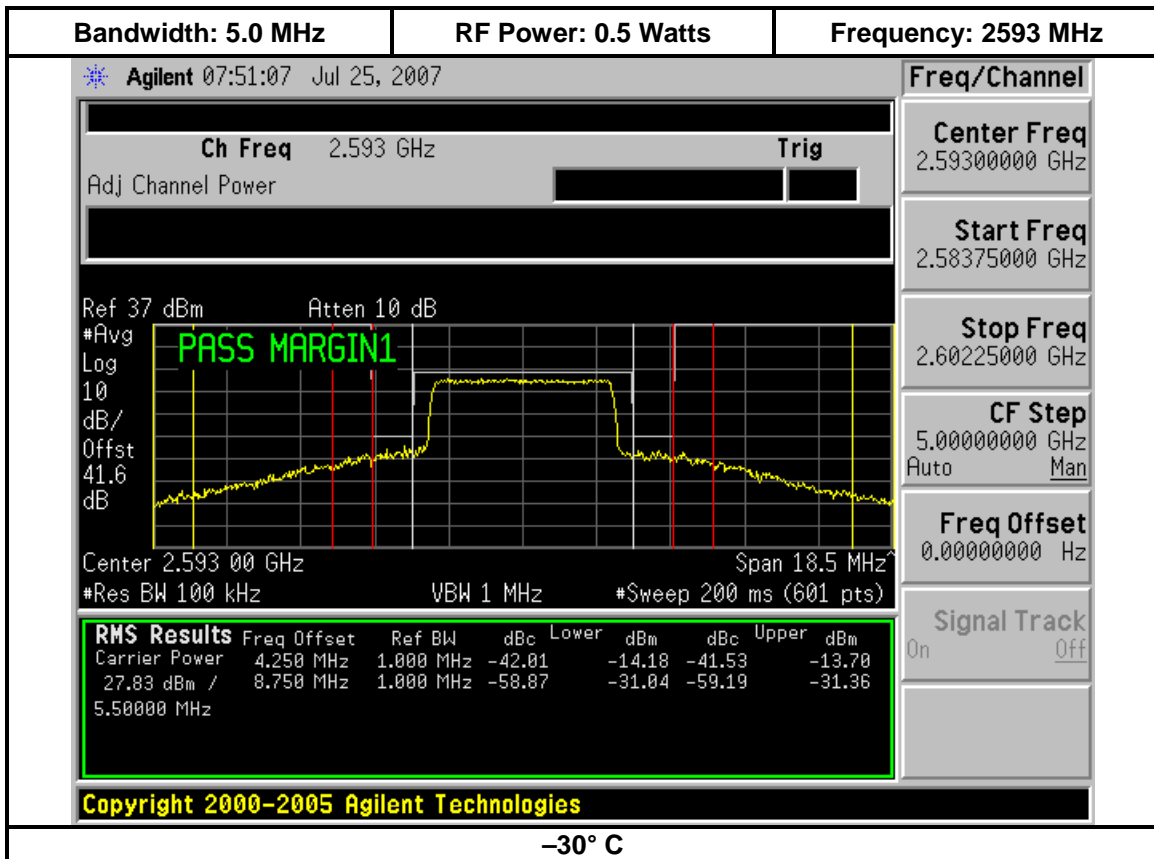

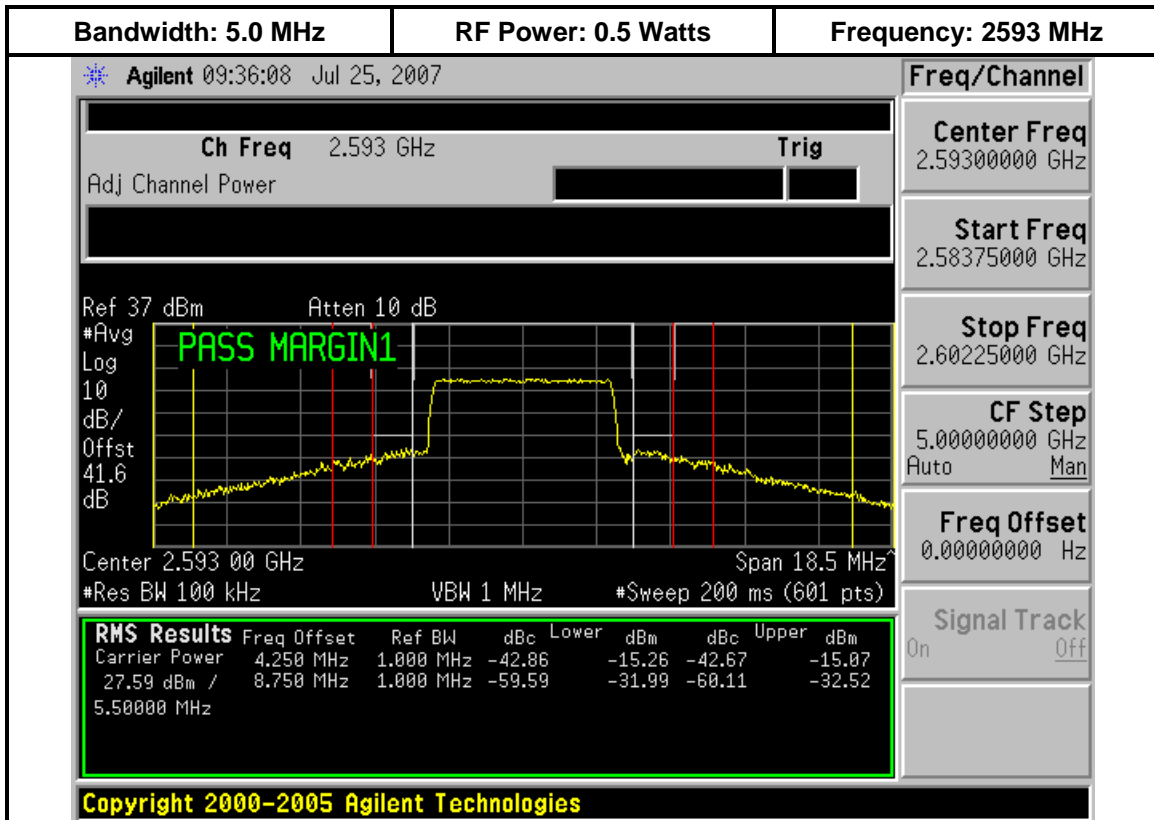

-20° C

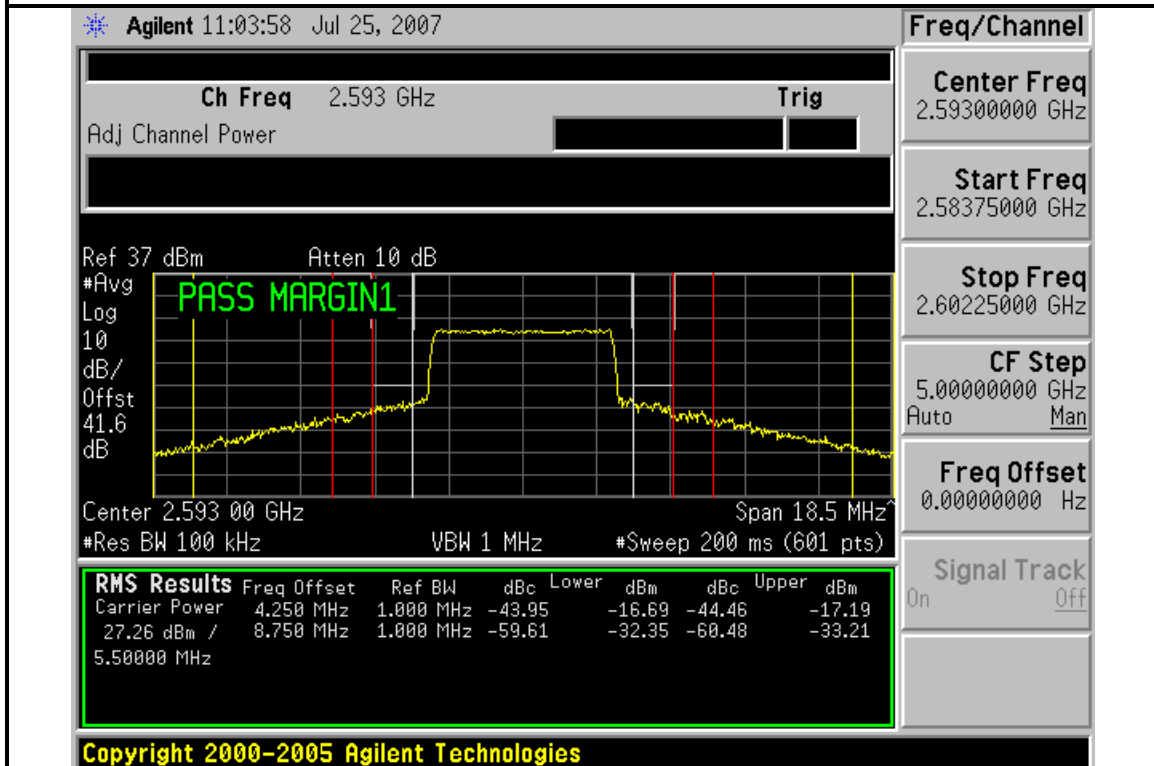

-10° C

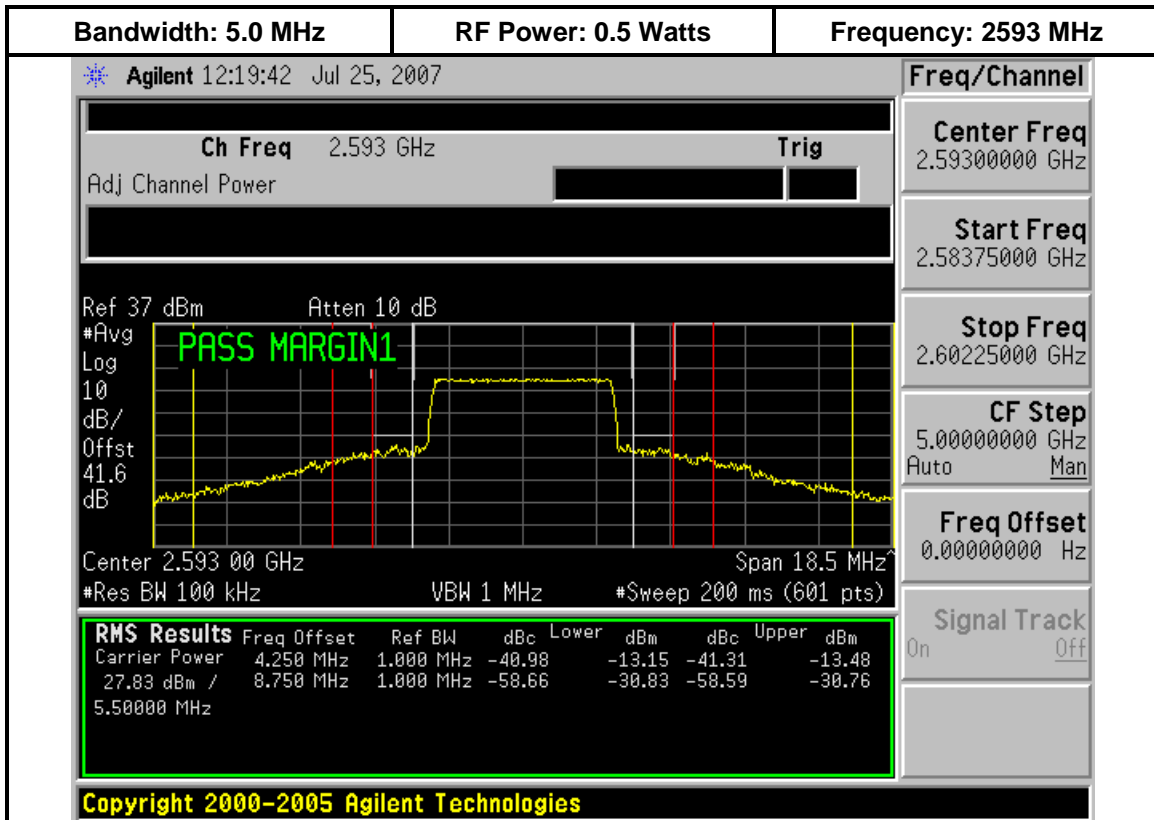

0° C

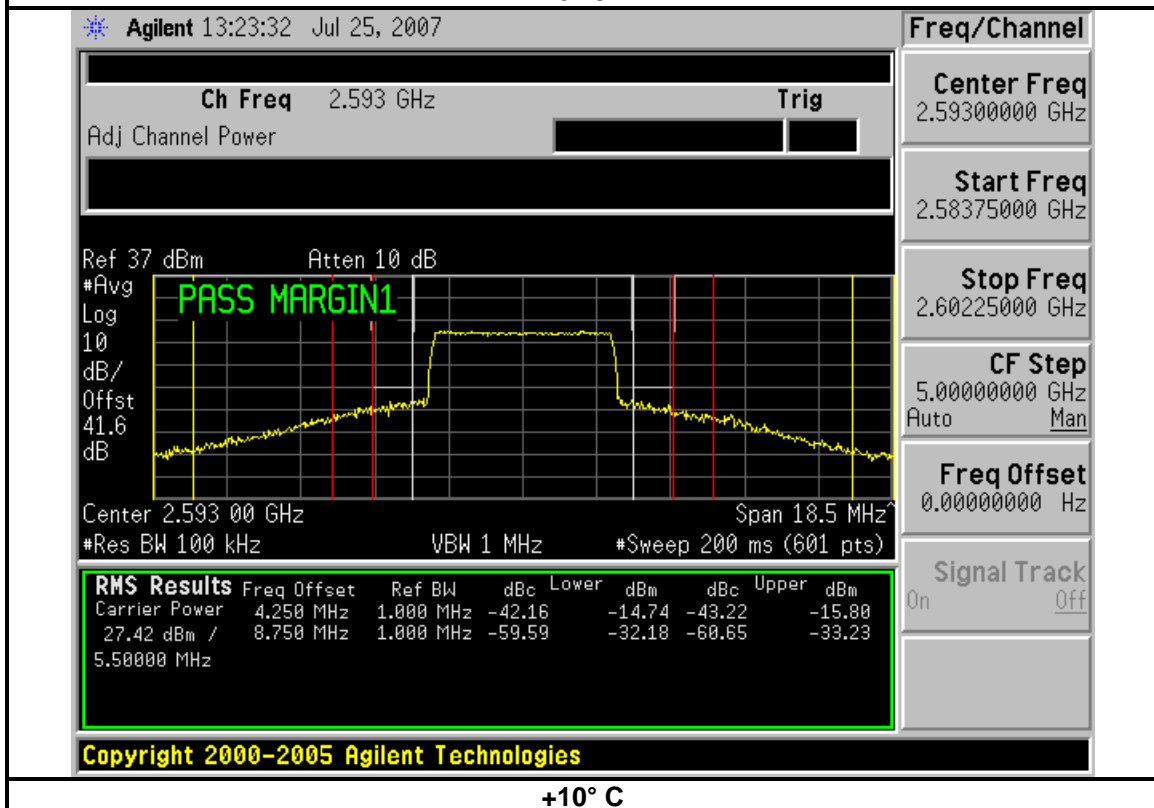

+10° C

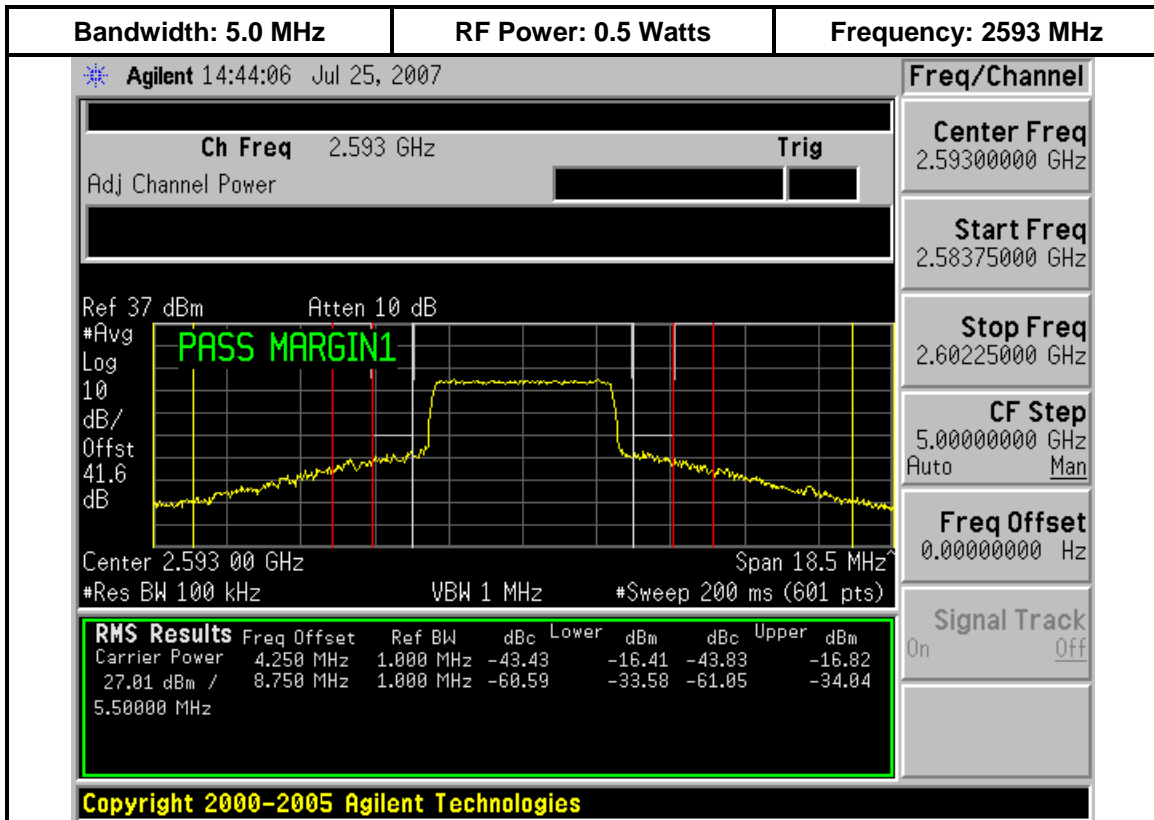

+20° C

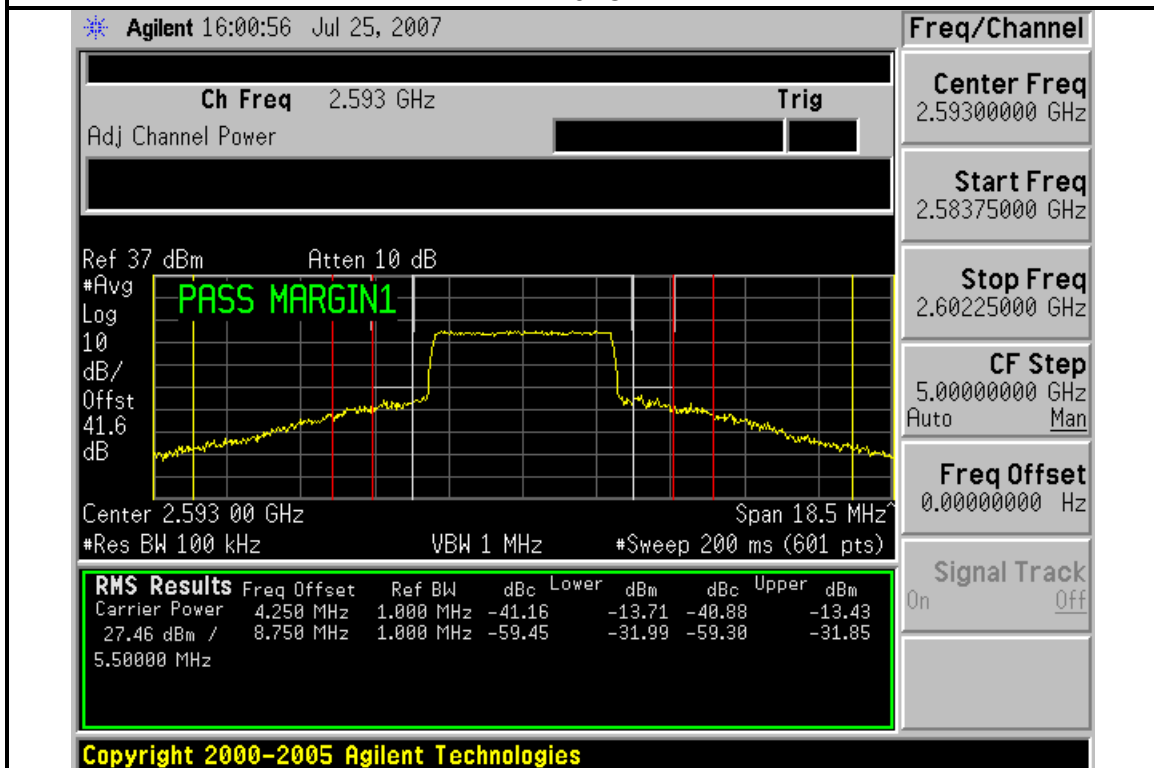

+30° C

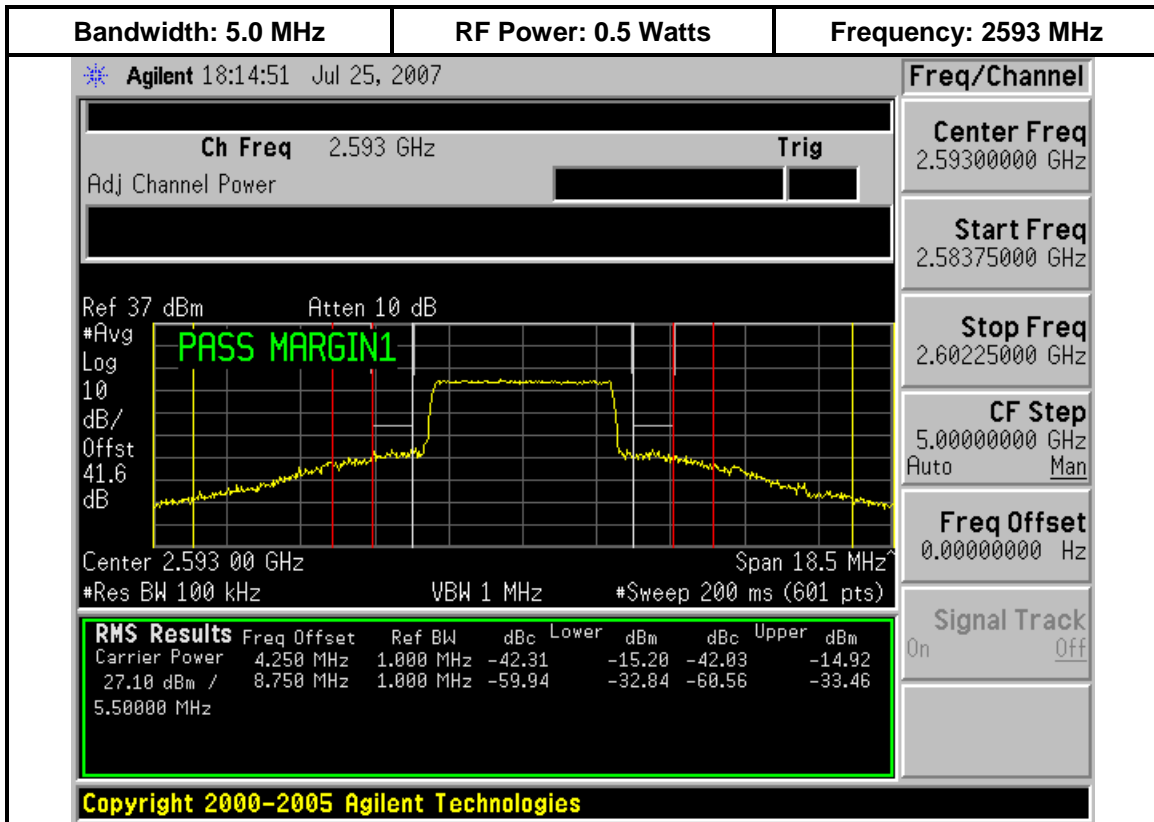

+40° C

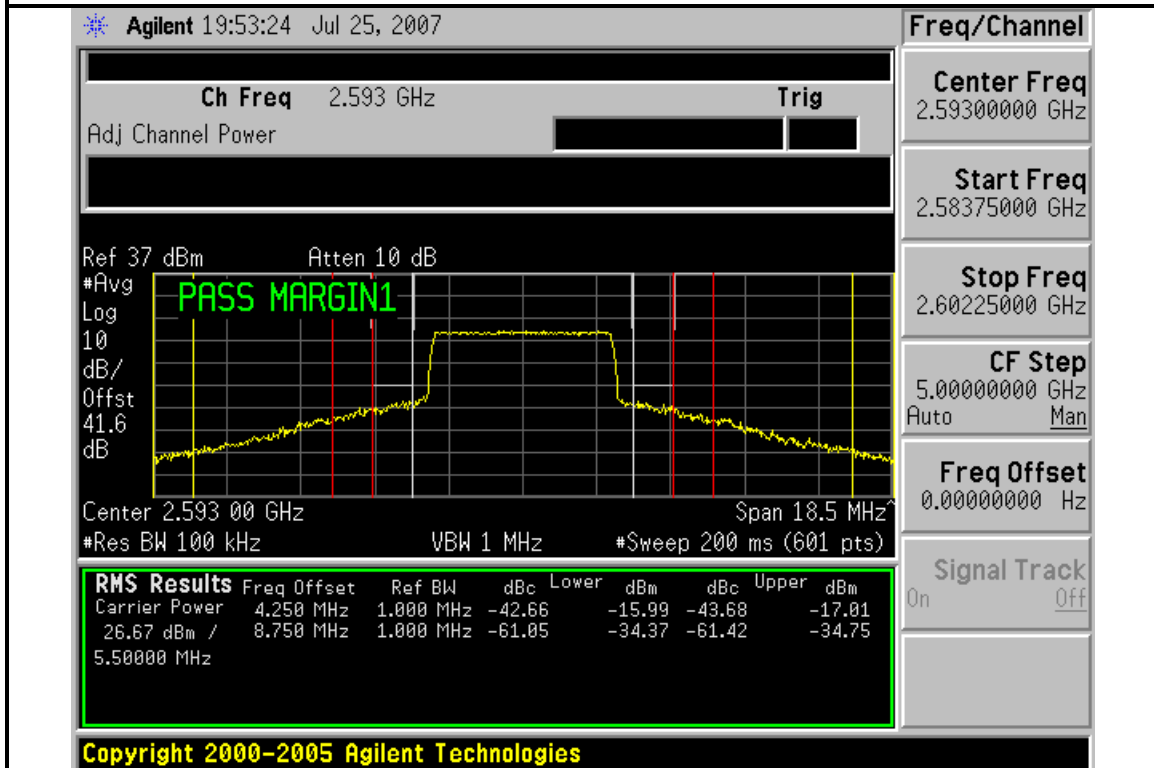

+50° C

5.8.3. Supply Voltage Variation Test Results

Test Conditions: **Frequency:** 2593 MHz
Temperature: 22°C
Source Input Voltage Specification: 120.0 VAC / 60 Hz Nominal
Test Voltage Range: 0.85 x 120 = 102 VAC / 60 Hz lower limit
 1.15 x 120 = 138 VAC / 60 Hz upper limit

Test Results: Supply Voltage Variation
 The tables below summarize the information from the plots contained in this section and in the Appendix.

Frequency Stability Emissions 20°C 2.593 GHz 5.0 MHz Bandwidth							
Source Voltage (Vdc)	a/A	b	B	Margin to -13 dBm limit	g	G	Margin to -25 dBm limit
102	Pass	-16.02	-16.78	3.02	-33.39	-33.19	8.19
120	Pass	-16.41	-16.82	3.41	-33.58	-34.04	8.58
138	Pass	-16.18	-16.54	3.18	-33.52	-33.87	8.52

Frequency Stability Emissions 20°C 2.593 GHz 10.0 MHz Bandwidth							
Source Voltage (Vdc)	a/A	b	B	Margin to -13 dBm limit	g	G	Margin to -25 dBm limit
102	Pass	-16.52	-16.89	3.52	-25.51	-25.34	.34
120	Pass	-17.49	-17.33	4.33	-25.09	-25.02	.02
138	Pass	-16.21	-16.78	3.21	-25.12	-25.21	.12

5.8.4. Supply Voltage Variation Spectrum Analyzer Plots

Spectrum analyzer plots of the 5.0 MHz bandwidth measurements follow. The plots for the 10 MHz bandwidth channels are similar and are located in Appendix B.

