

Exhibit 6

Test Report

FCC Part 27

**EXHIBIT 6, PART 1
TABLE OF CONTENTS**

TEST EQUIPMENT LIST 3

CONDUCTED RF POWER OUTPUT 4
 Conducted RF Output Test Results Summary5
 Conducted RF Power Output Spectrum Analyzer Plots6

MODULATION CHARACTERISTICS..... 30
 Modulation Characteristics Test Results32
 Modulation Characteristics Spectrum Analyzer Plots43

OCCUPIED BANDWIDTH / EMISSION BANDWIDTH..... 50
 Occupied and Emission Bandwidth Test Results Summary52
 Occupied Bandwidth Spectrum Analyzer Plots53
 Emission Bandwidth Spectrum Analyzer Plots65

SPURIOUS EMISSIONS AT ANTENNA TERMINALS..... 77
 Spurious Emissions At Antenna Terminals Spectrum Analyzer Plots79

FREQUENCY STABILITY TEST 95
 Frequency Stability Temperature Variation Test Results97
 Temperature Variation Spectrum Analyzer Plots98
 Frequency Stability Supply Voltage Variation Test Results103
 Frequency Stability Voltage Variation Spectrum Analyzer Plots104

Test Equipment List

Test Equipment	Description
DUT	NextNet Wireless CPE Model OSU-2510-AV P/N 900-0055-1000 S/N 0016X494SCAX00133210
Spectrum Analyzer	Agilent E4440A S/N: MY44022791 Calibrated on: 05/30/2004 Cal due: 05/30/2006
Attenuators and coax 2- 20 dB	Pasternak Corporation Model: PE7005-20 (20 dB) x 2 Calibrated by user
Notch Filter/Attenuator/ Coaxial Cable (harmonic frequency test only)	Filter and assembly calibrated by user Pasternack PE7005-20 20 dB, 2W attenuator
Computer	Dell Inspiron 5000 Model: PPM S/N: 000832RM-12961-04R-0441
Ethernet Switch	D-Link Model: DSS-5+ 5 port 10/100Mbps S/N: B205335003173
Power Supply (All Tests Except Frequency Stability)	NextNet Wireless 19.5 VDC, 2.56 A P/N GS-741 Model GT-21097-5024-4.5
Power Supply (Frequency Stability Test Only)	Agilent E3620A S/N: MY40004365 Calibrated with voltmeter listed below.
Voltmeter	HP 34401A S/N: 3146A9519 Calibrated on: 6-29-2004 Cal due: 6-29-2006
Temperature Chamber	Test Equity 1000 Series
Temperature Sensor	Fluke 89 IV True RMS Multimeter K-Type Thermocouple
Radiation Hazard Meter	General Microwave Corporation RAHAM Model 3 Cal Date: 10-14-2003 Cal Due: 10-14-2005

Conducted RF Power Output

Rule Part Number: 2.1046, 27.50(h)(2)
Tx Power \leq 2.0 watts

Standard: TIA-603-B
TIA Standard, Land Mobile FM or PM Communications
Equipment, Measurement and Performance Standards

Test Procedure: The conducted RF output power was measured with a spectrum analyzer utilizing the power measurement function. The RF output is applied to an attenuator that is connected to the spectrum analyzer RF input port. The spectrum analyzer is time gated to capture the transmission during the burst. An RMS detector is used to measure the average power during the transmission. The transmitter is enabled in test mode by the attached computer. The RF loss of the attenuators and coax has been measured and is included in the spectrum analyzer offset level and is noted on the block diagram. Measurements are performed at several frequencies across the band for each of the modulation formats available (4-, 16-, and 64-QAM) and channel bandwidths (5.5 MHz and 6.0 MHz).

Test Conditions: Frequencies =
5.5 MHz channels: 2504.75, 2565.25, 2626.75, 2687.25 MHz
6.0 MHz channels: 2499, 2575, and 2621 MHz
Temperature = 25°C
Supply Voltage = 19.5 VDC Nominal to DUT

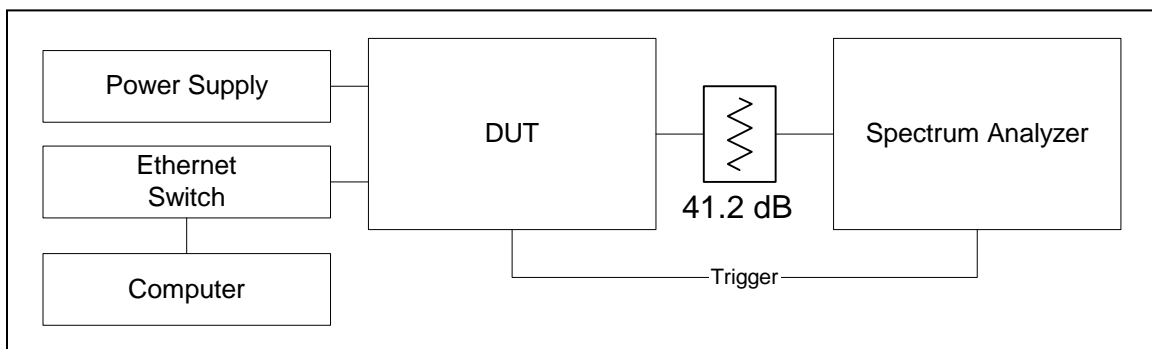

Conducted RF Power Test Setup

Conducted RF Output Test Results Summary

Maximum Power Setting						
	4 QAM		16 QAM		64 QAM	
Freq (MHz)	(dBm)	(Watts)	(dBm)	(Watts)	(dBm)	(Watts)
2504.75	32.12	1.63	32.14	1.64	32.16	1.64
2565.25	32.13	1.63	32.13	1.63	32.16	1.64
2626.75	32.65	1.84	32.68	1.85	32.61	1.82
2687.25	32.55	1.80	32.56	1.80	32.55	1.80
2499.00	32.12	1.63	32.09	1.62	32.13	1.63
2575.00	32.03	1.60	32.00	1.58	32.03	1.60
2621.00	32.82	1.91	32.85	1.93	32.84	1.92

Minimum Power Setting						
	4 QAM		16 QAM		64 QAM	
Freq (MHz)	(dBm)	(Watts)	(dBm)	(Watts)	(dBm)	(Watts)
2504.75	0.37	0.00109	0.33	0.00108	0.35	0.00108
2565.25	0.32	0.00108	0.31	0.00107	0.33	0.00108
2626.75	-0.51	0.00089	-0.51	0.00089	-0.47	0.00090
2687.25	-0.18	0.00096	-0.16	0.00096	-0.17	0.00096
2499.00	0.28	0.00107	0.31	0.00107	0.30	0.00107
2575.00	0.23	0.00105	0.23	0.00105	0.22	0.00105
2621.00	-0.38	0.00092	-0.42	0.00091	-0.40	0.00091

Conducted RF Power Output Spectrum Analyzer Plots 4-QAM

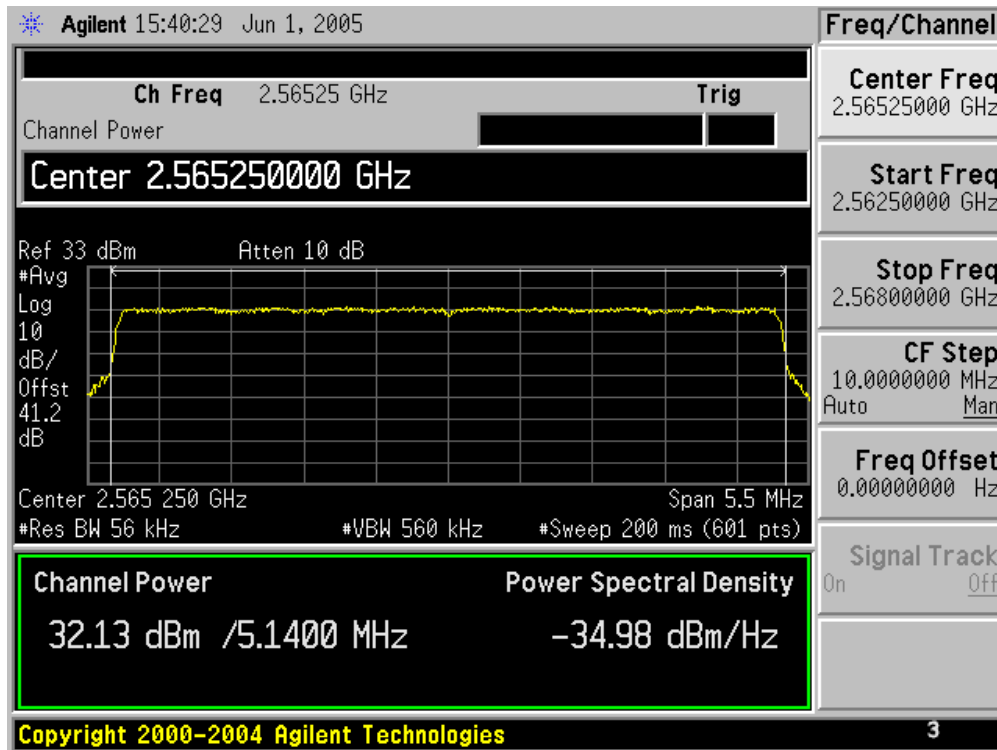
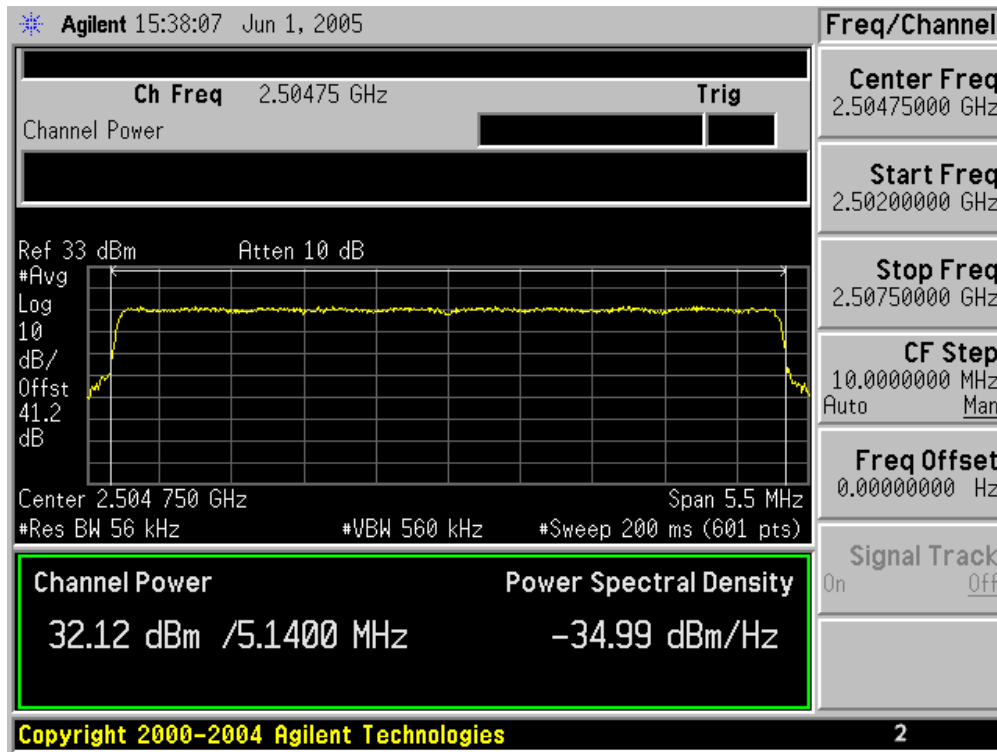

RF Power Output – Conducted (Maximum) 4-QAM (Cont'd)

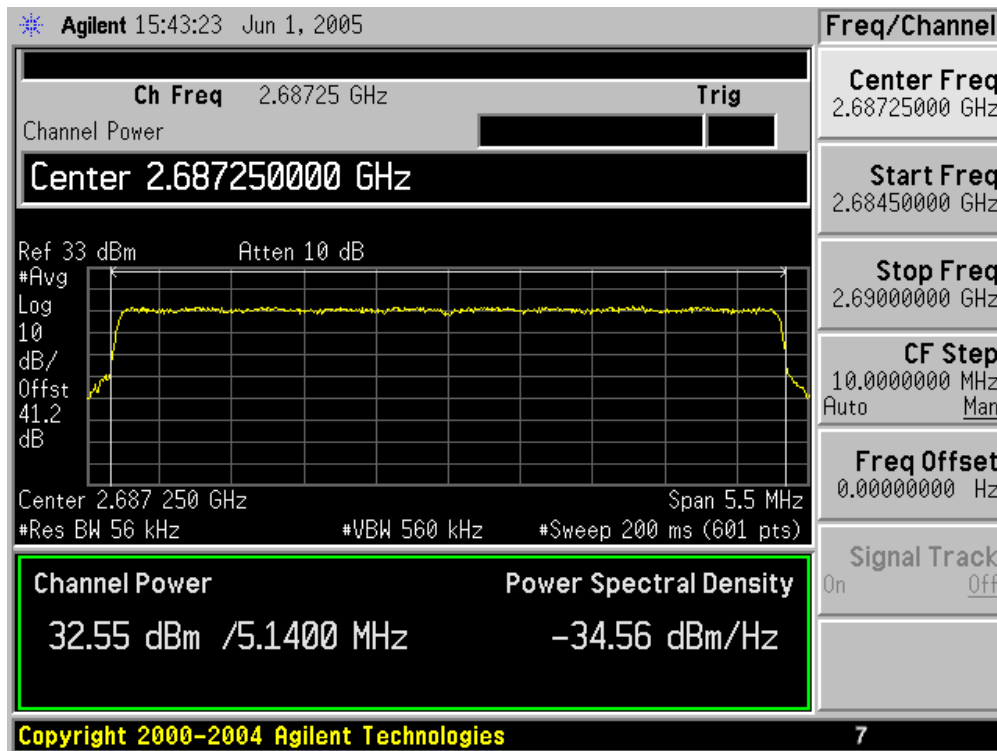
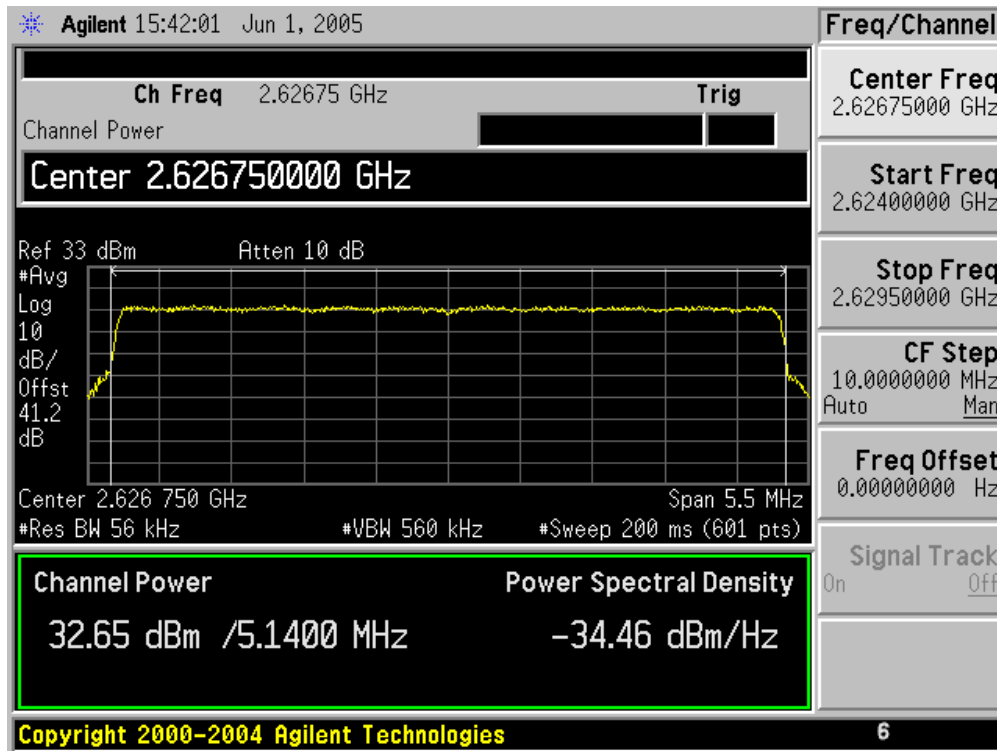

RF Power Output – Conducted (Maximum) 4-QAM (Cont'd)

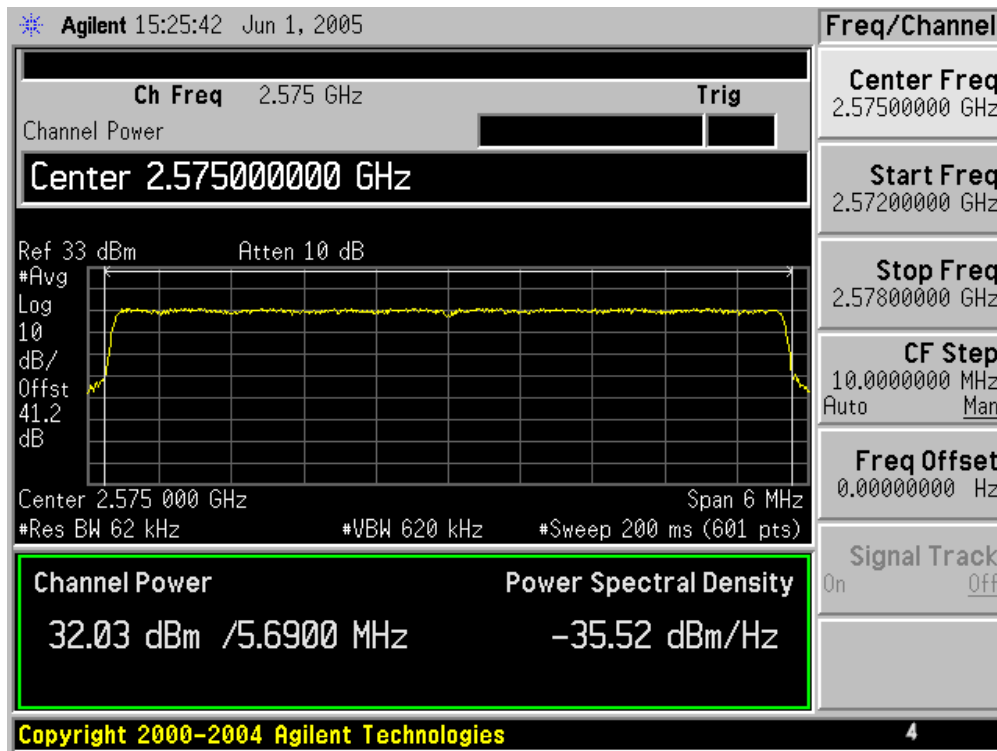
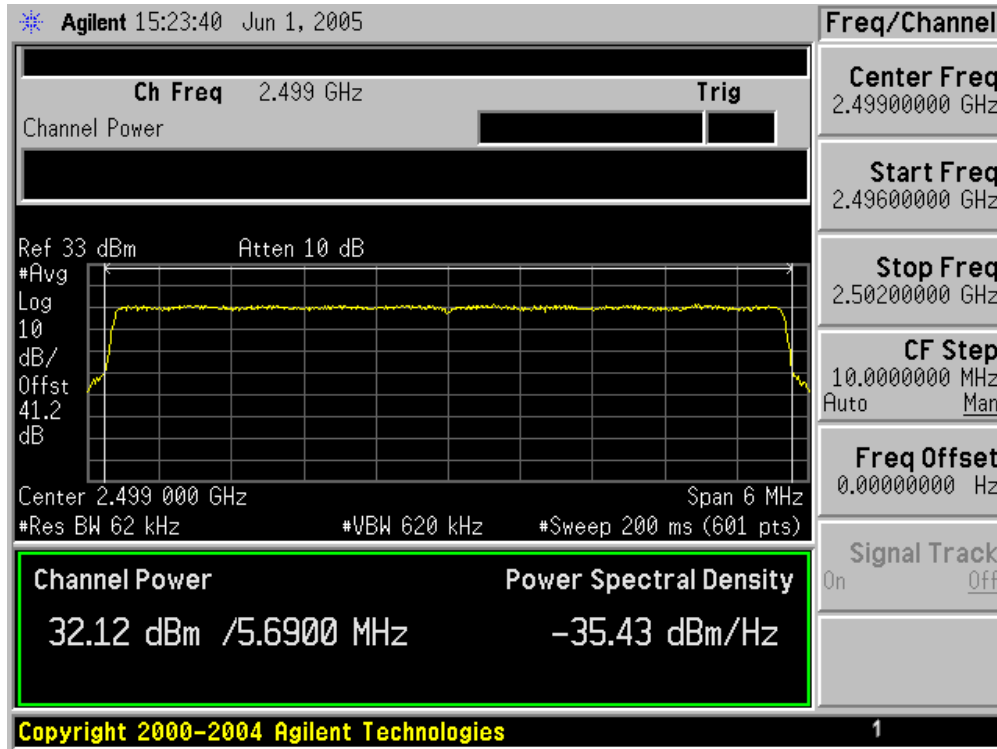

RF Power Output – Conducted (Maximum) 4-QAM (Cont'd)

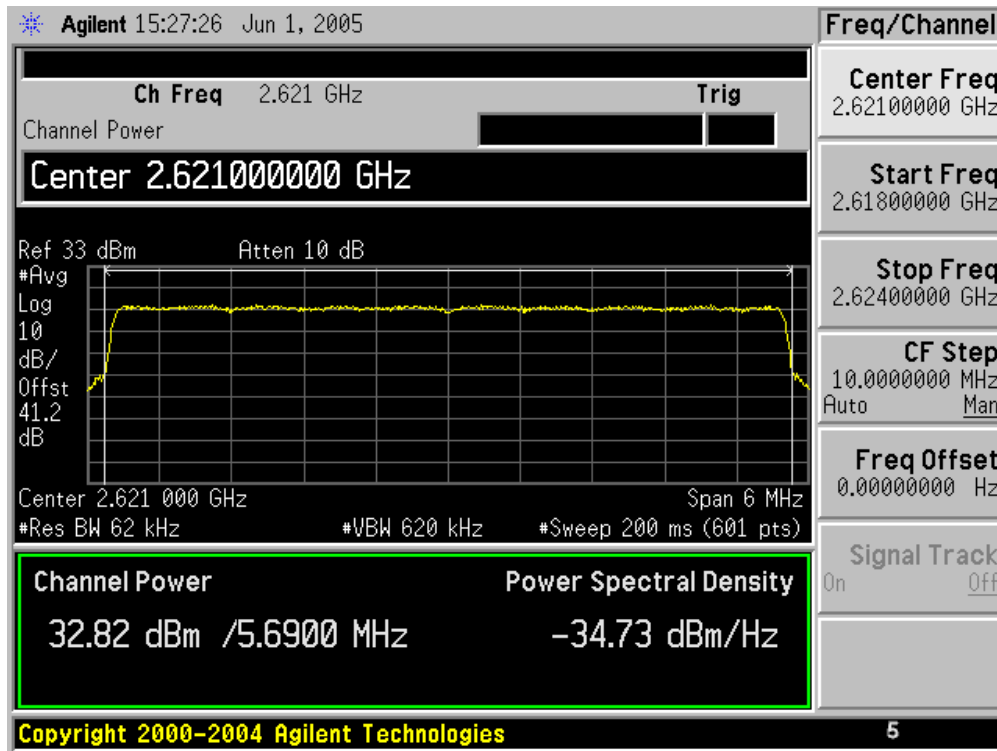

RF Power Output – Conducted (Maximum) 16-QAM

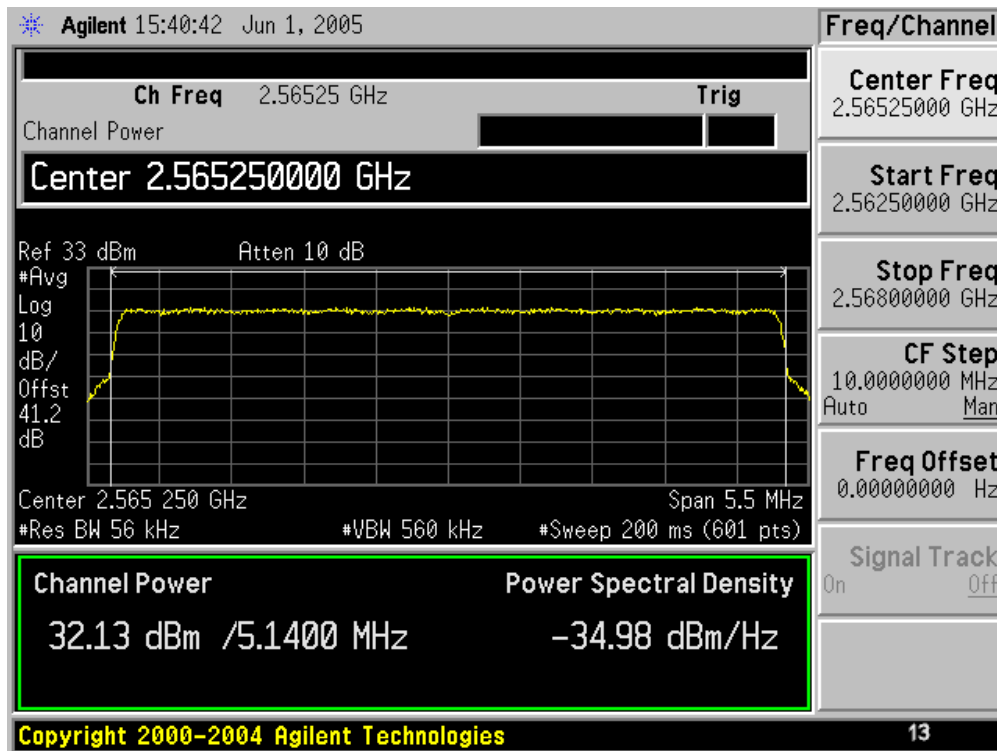
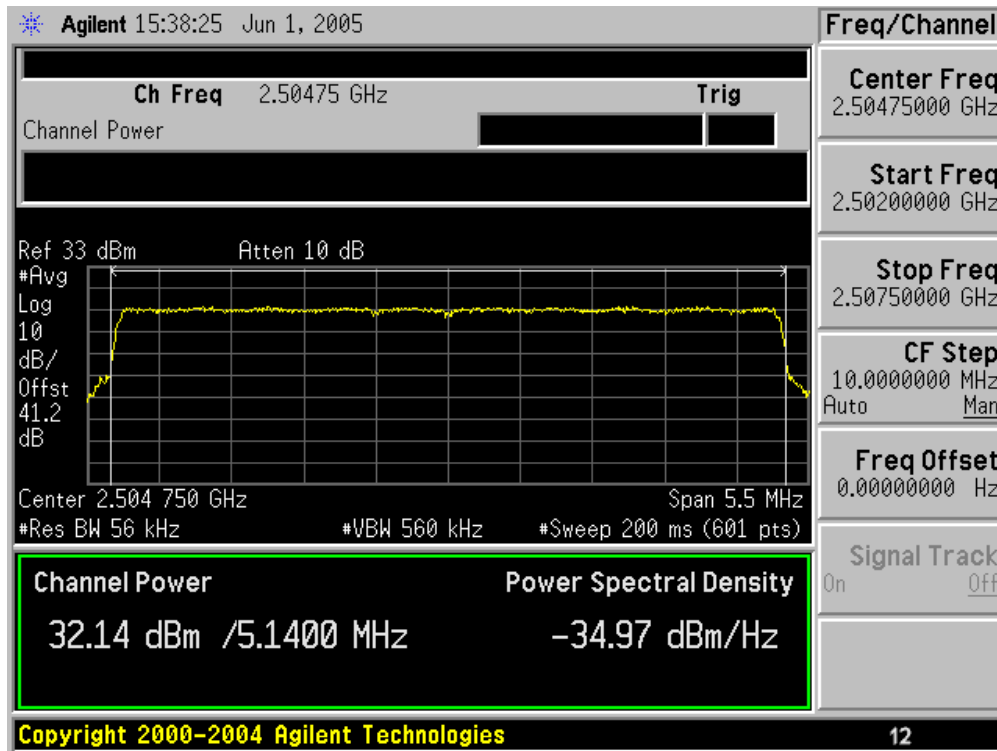

RF Power Output – Conducted (Maximum) 16-QAM (Cont'd)

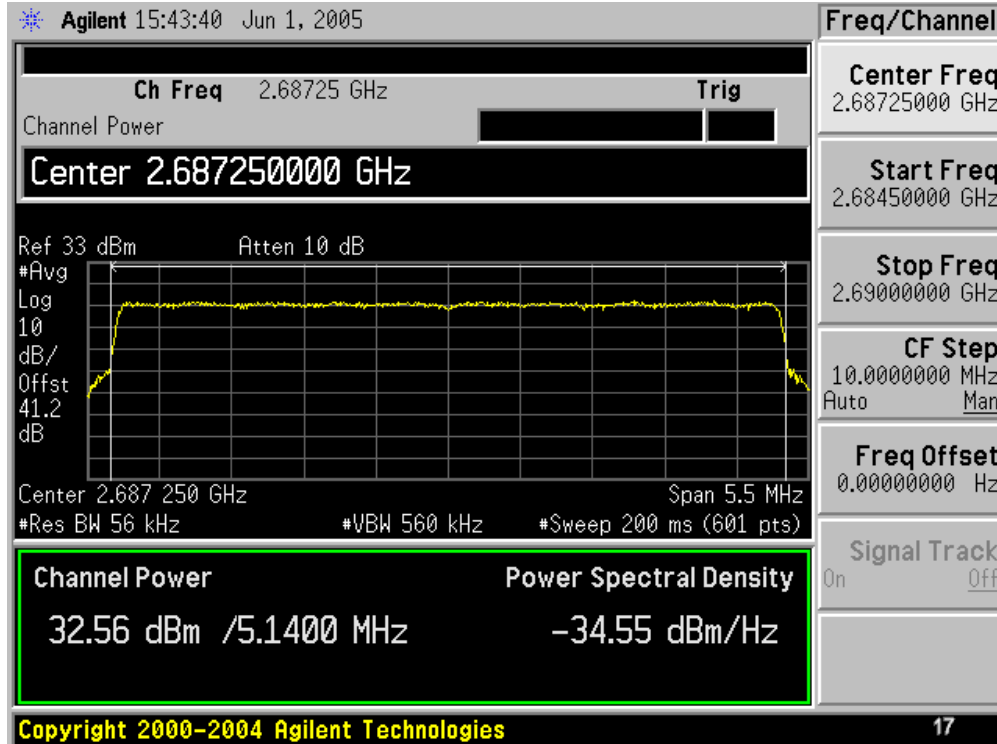
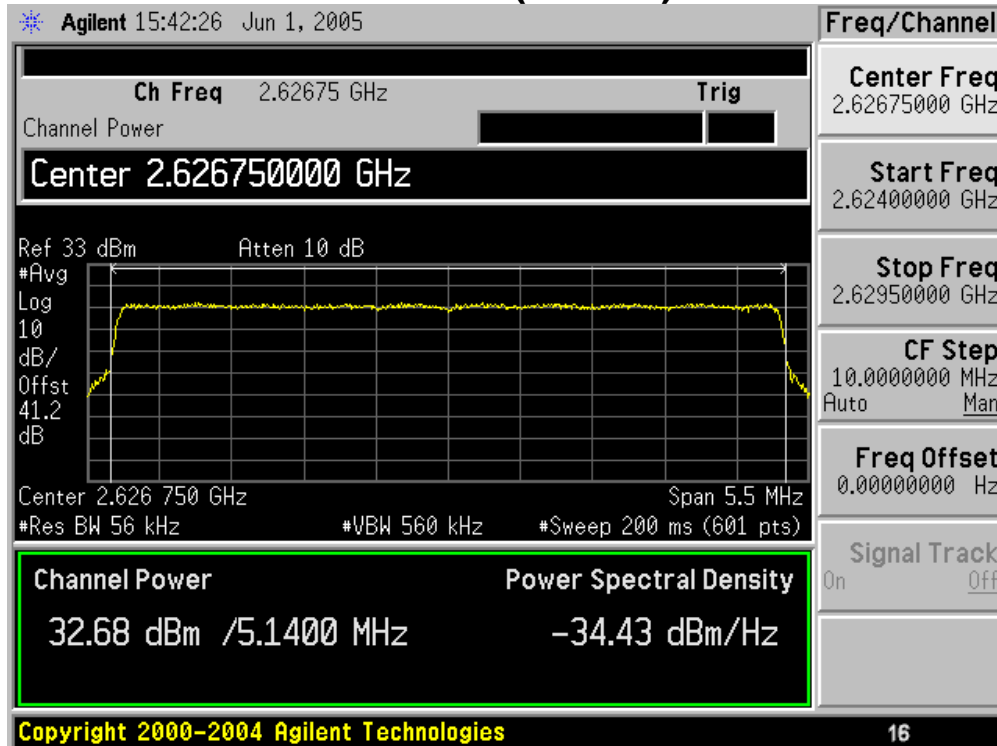

RF Power Output – Conducted (Maximum) 16-QAM (Cont'd)

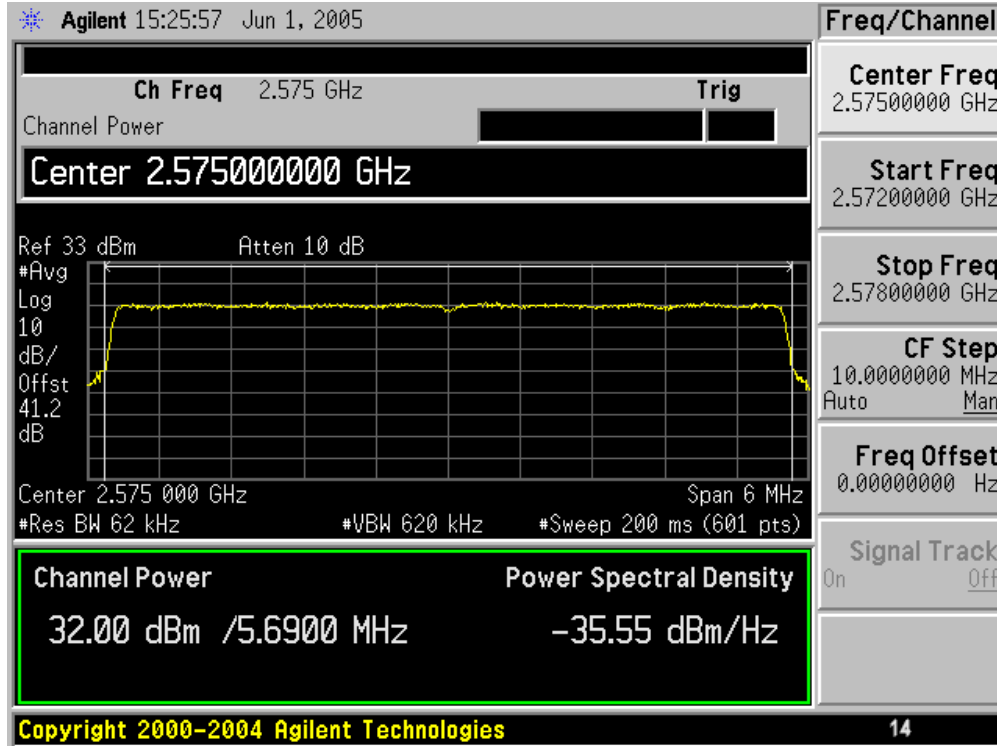
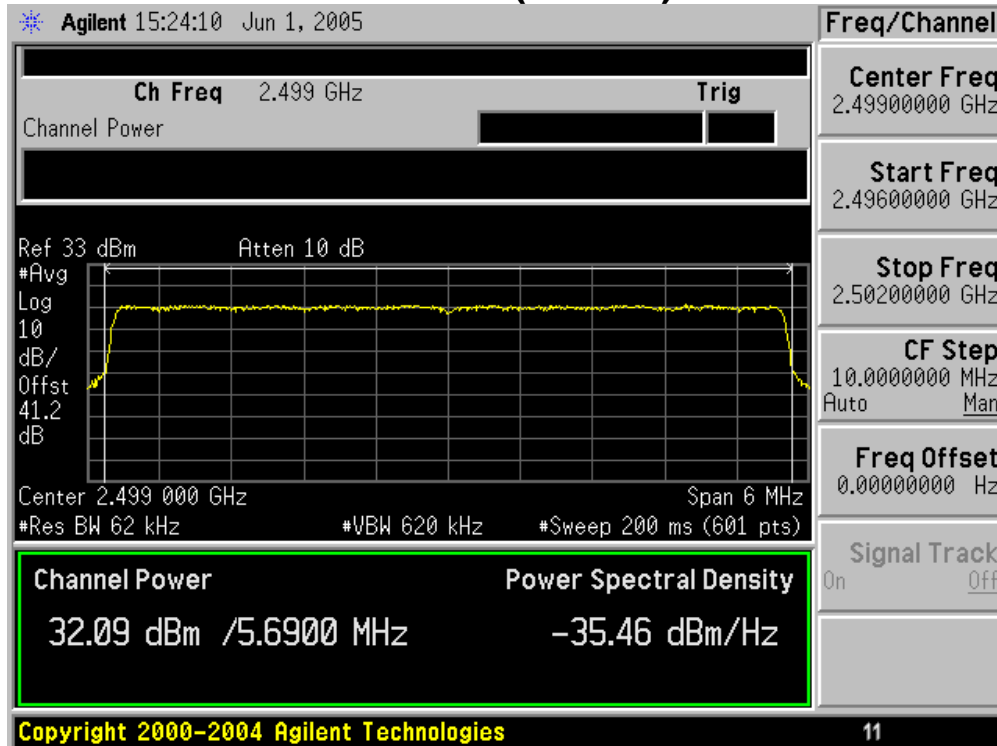

RF Power Output – Conducted (Maximum) 16-QAM (Cont'd)

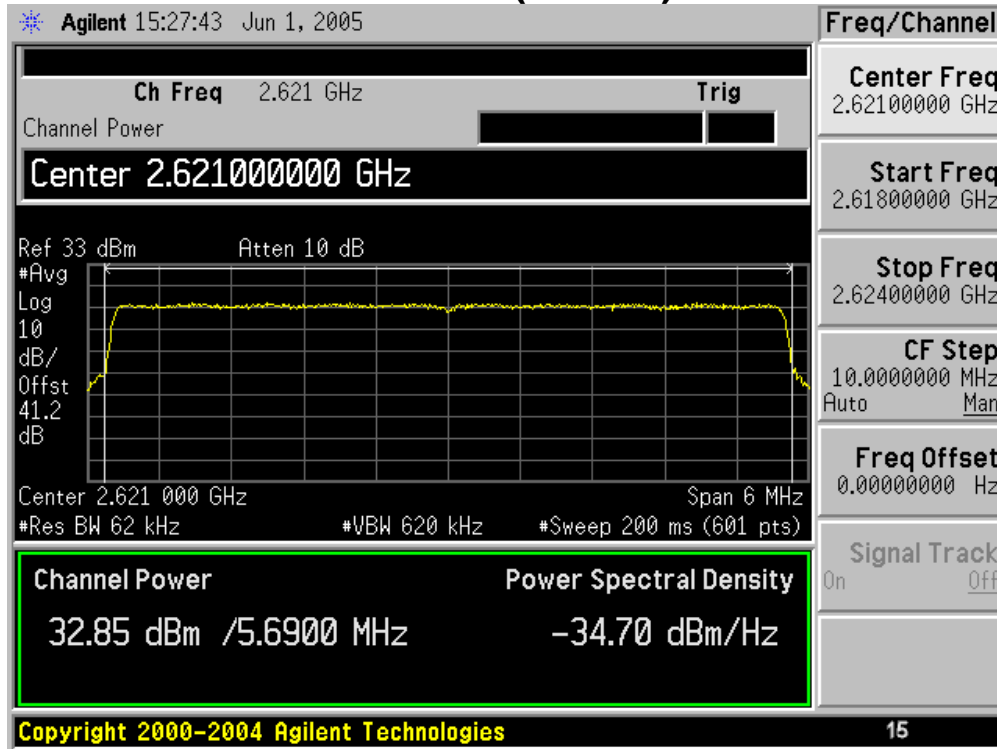

RF Power Output – Conducted (Maximum) 64-QAM

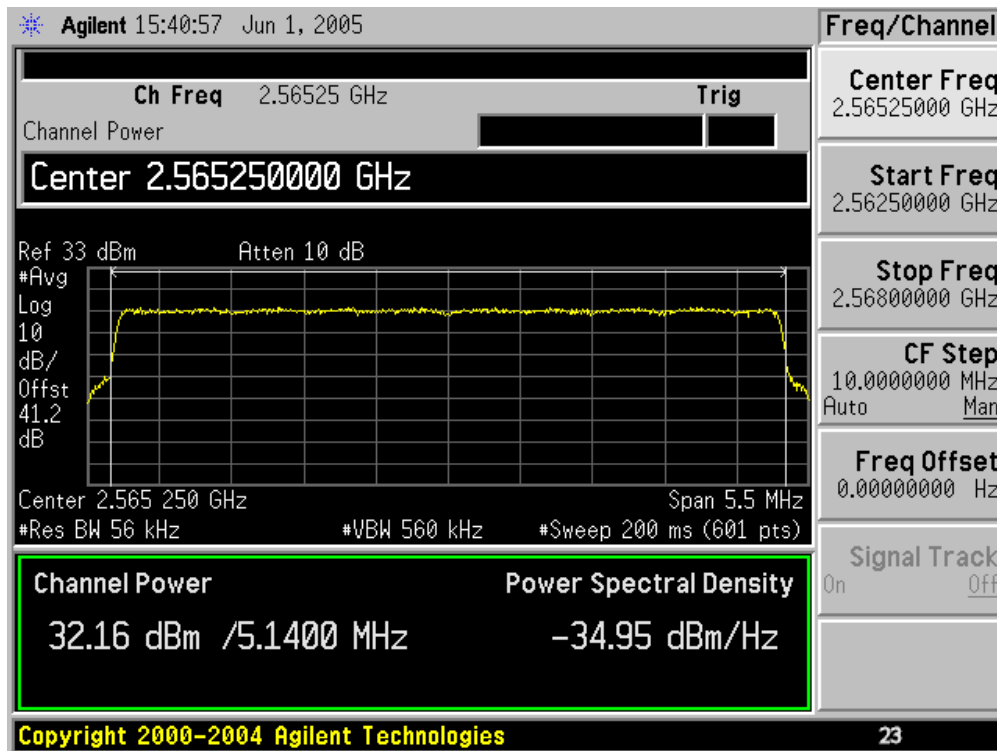
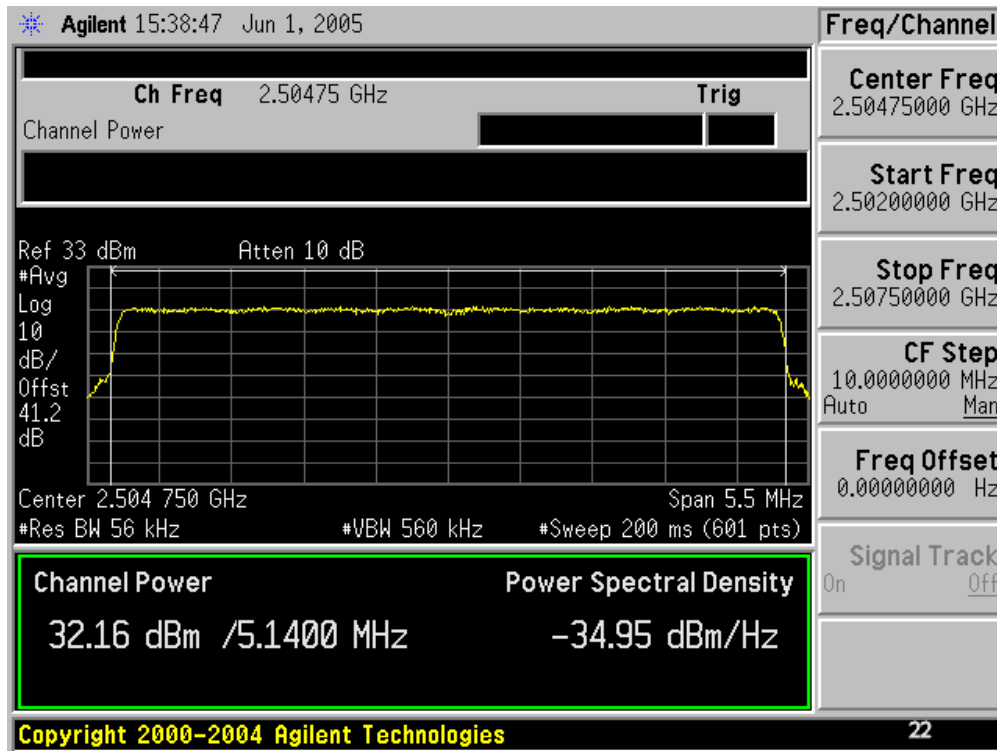

RF Power Output – Conducted (Maximum) 64-QAM (Cont'd)

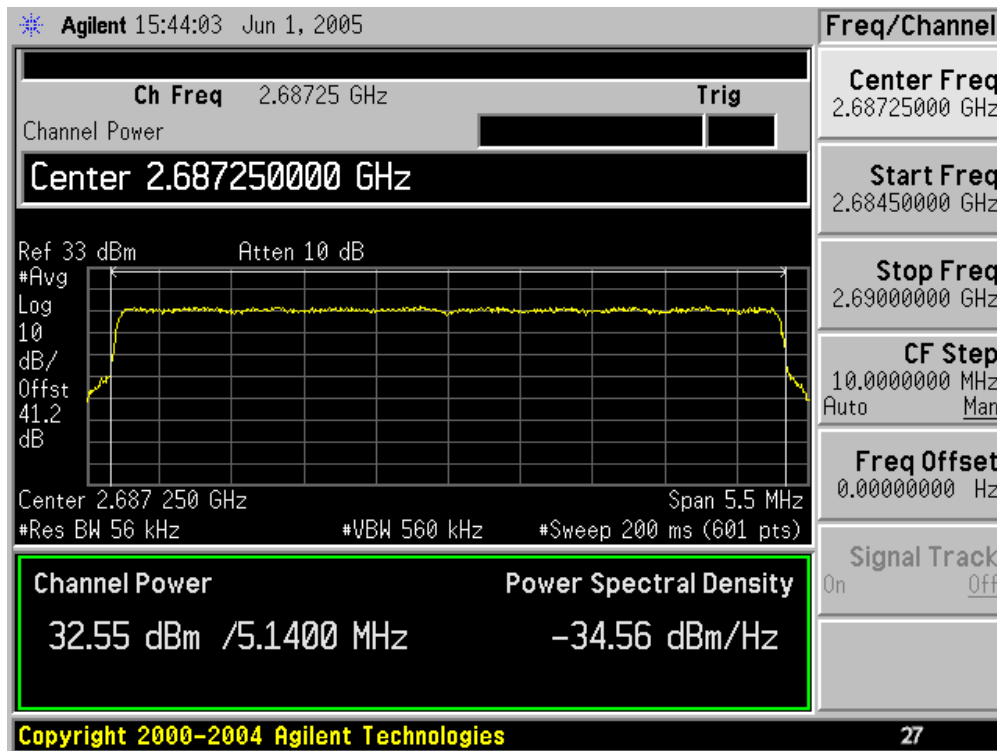
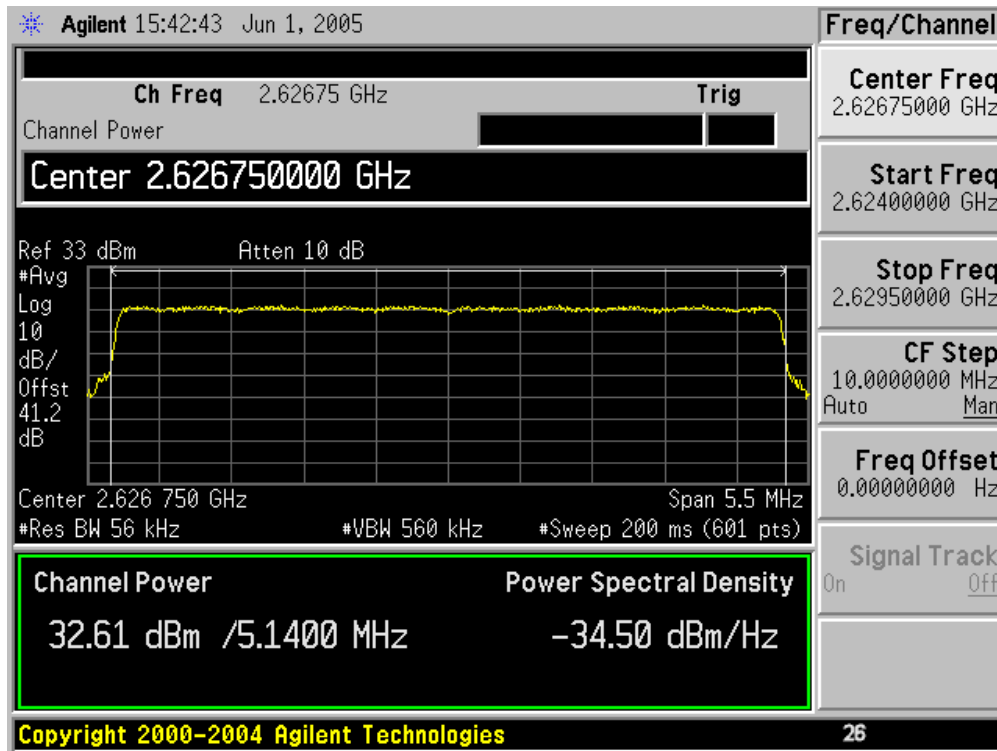

RF Power Output – Conducted (Maximum) 64-QAM (Cont'd)

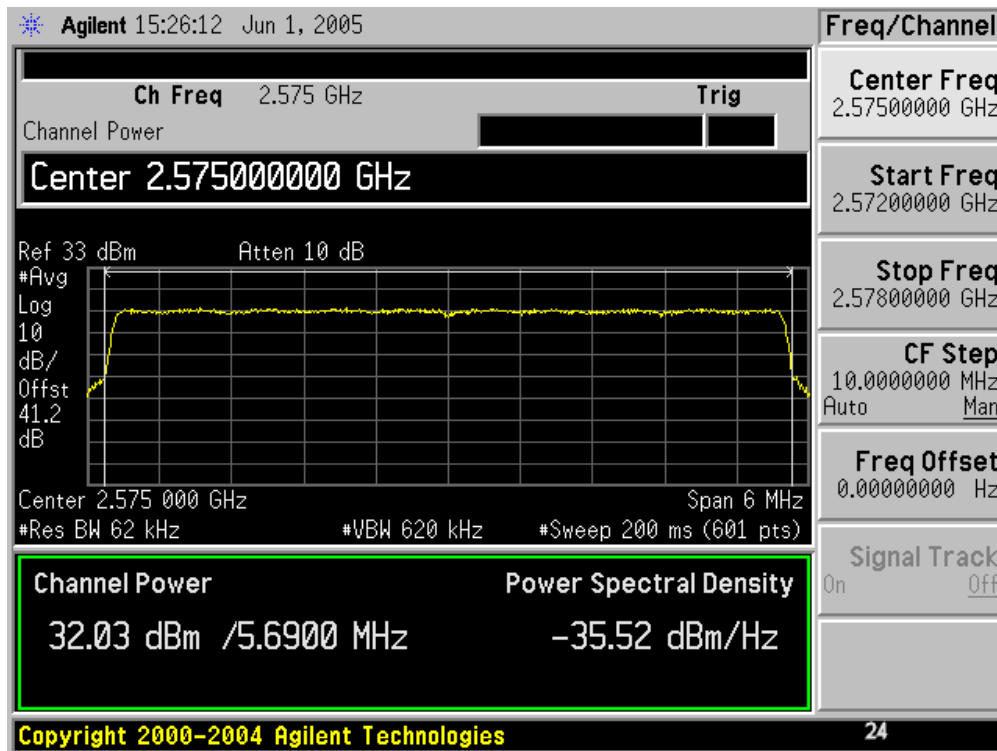
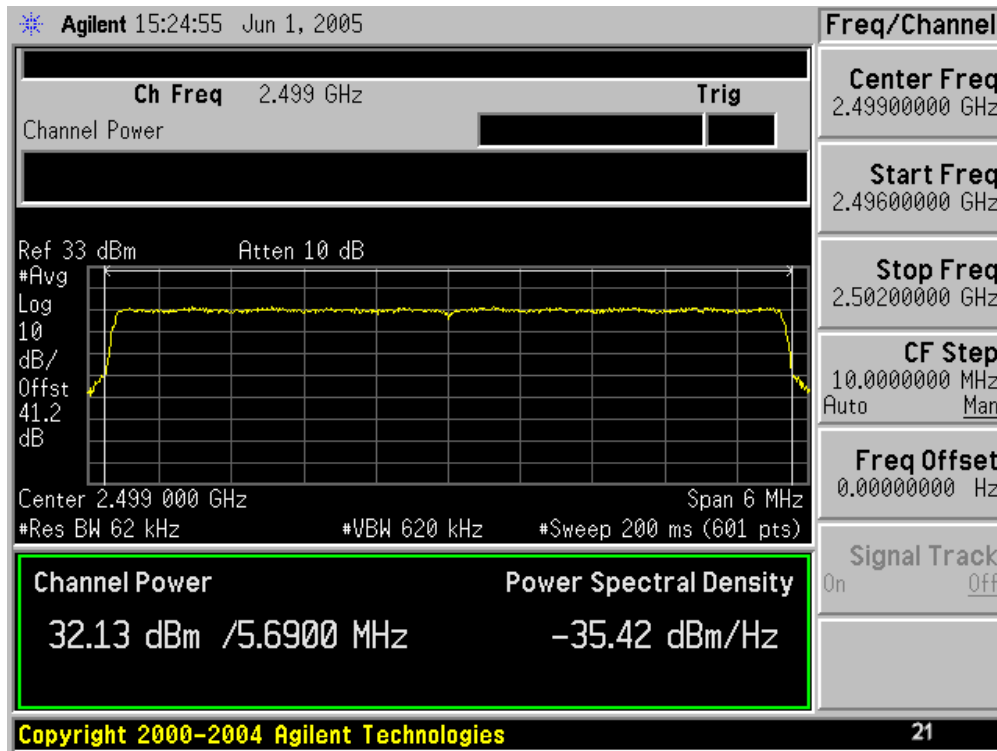

RF Power Output – Conducted (Maximum) 64-QAM (Cont'd)

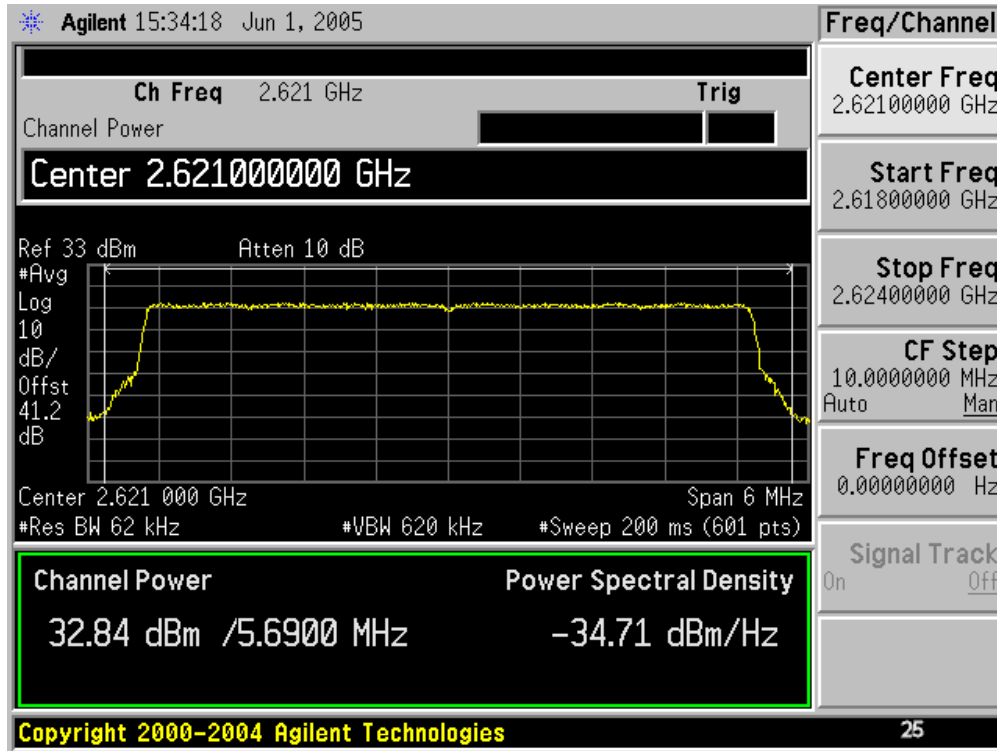

RF Power Output – Conducted (Minimum) 4-QAM

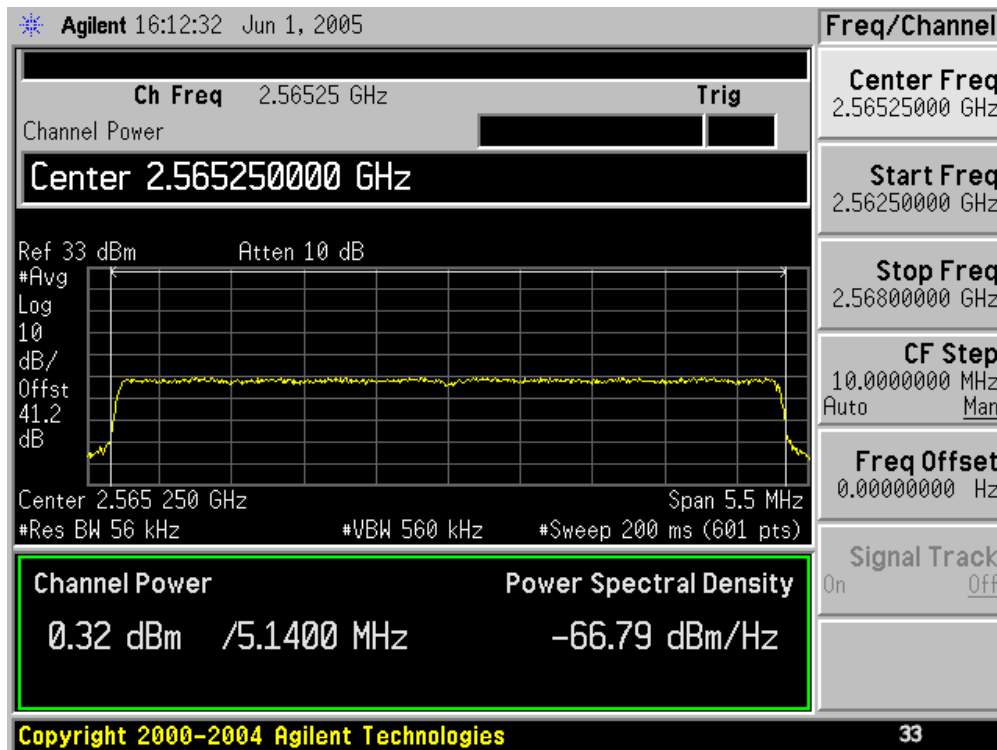
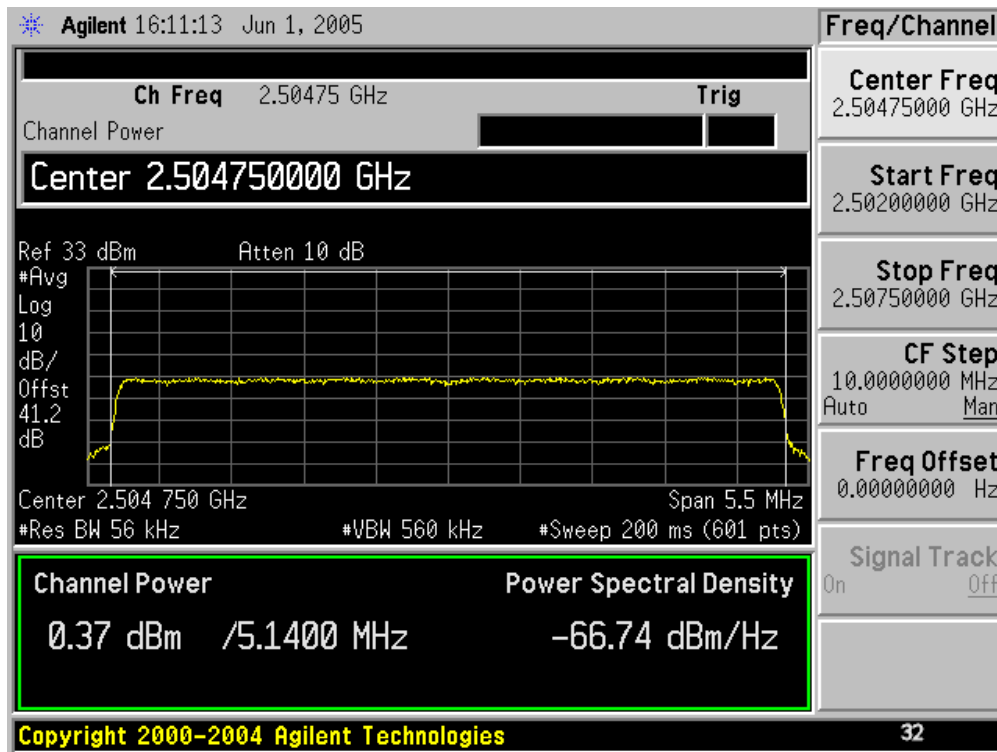

RF Power Output – Conducted (Minimum) 4-QAM (Cont'd)

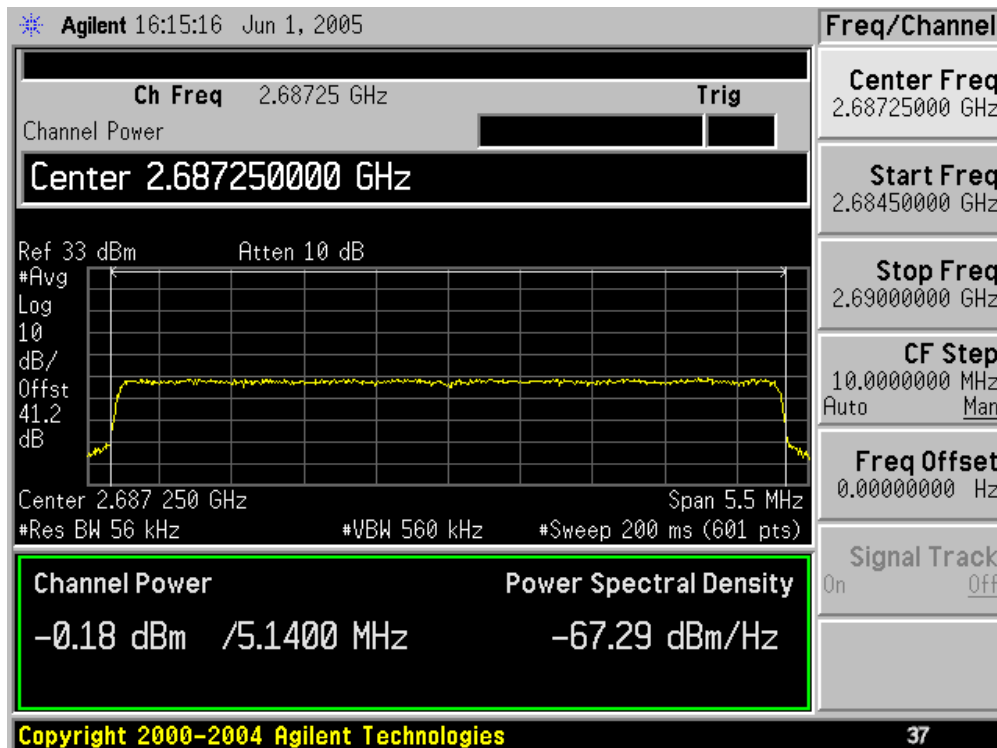
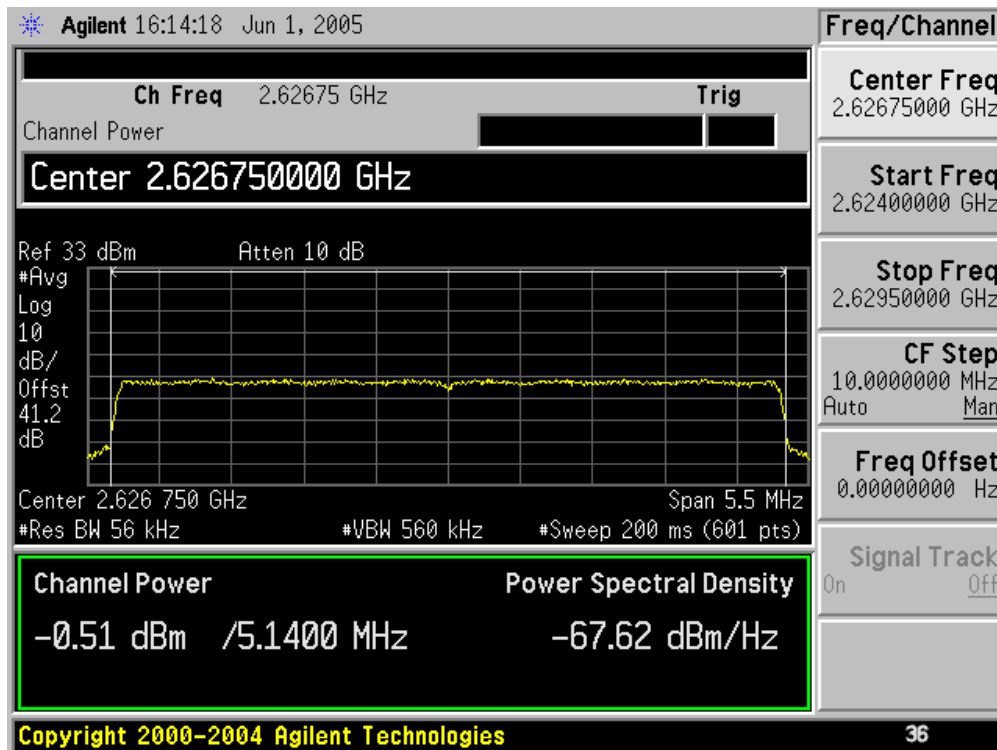

RF Power Output – Conducted (Minimum) 4-QAM (Cont'd)

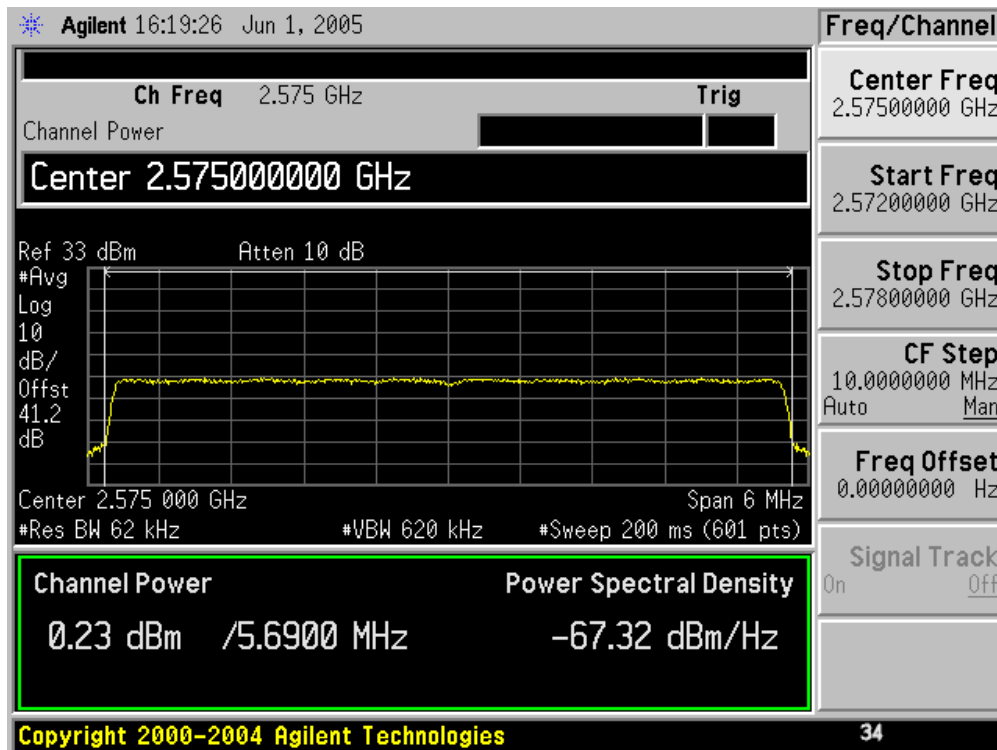
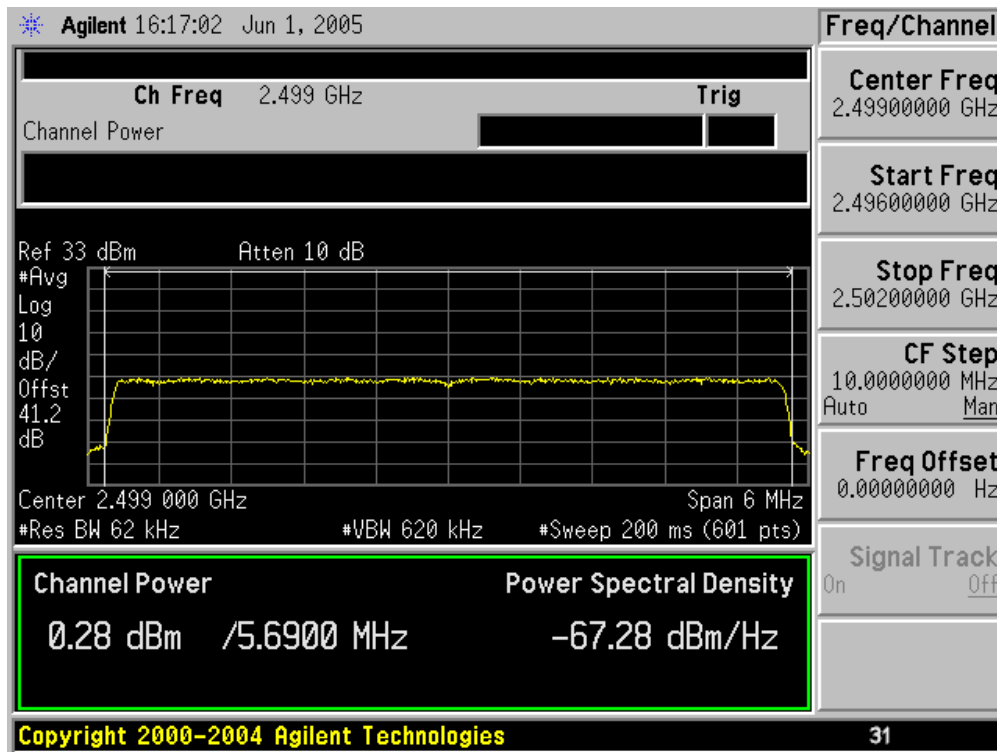

RF Power Output – Conducted (Minimum) 4-QAM (Cont'd)

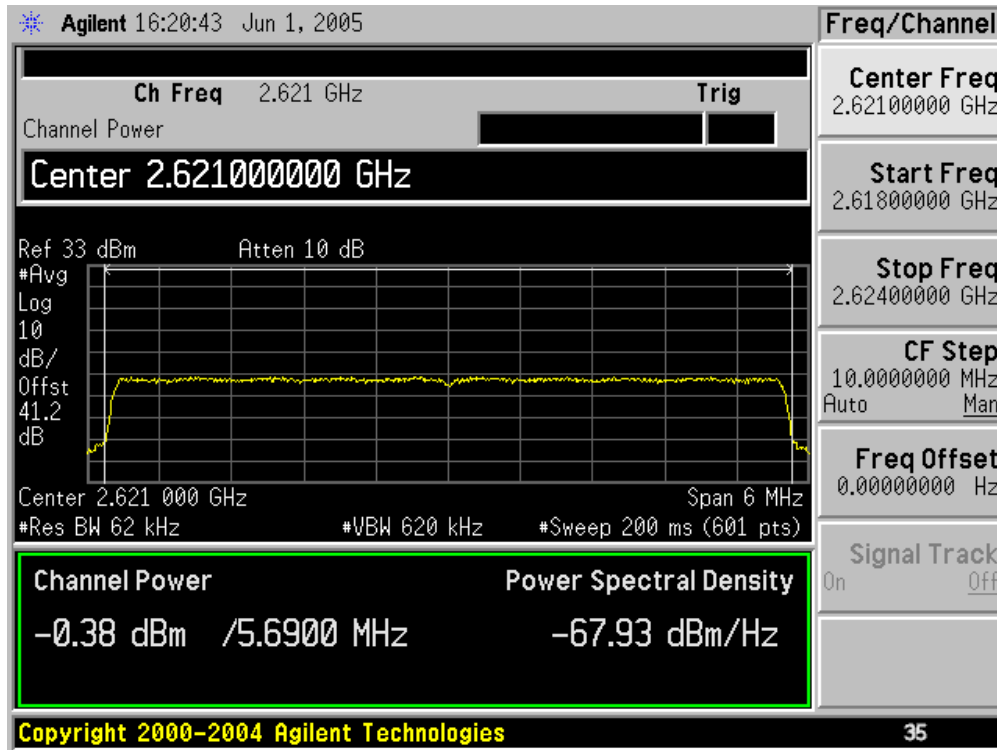

RF Power Output – Conducted (Minimum) 16-QAM

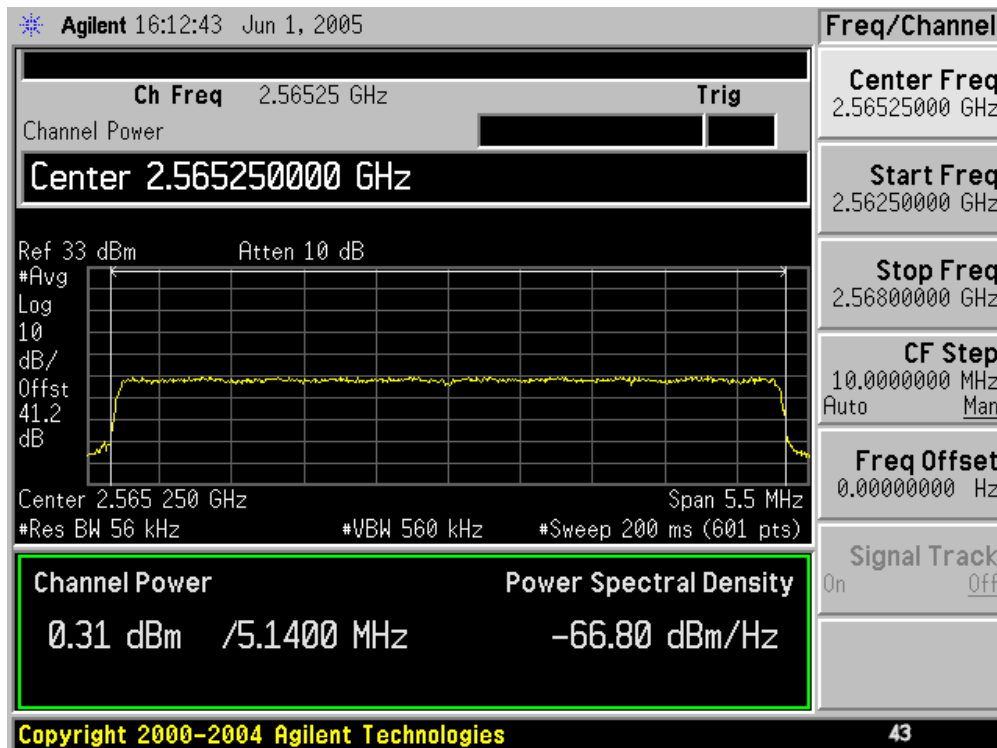
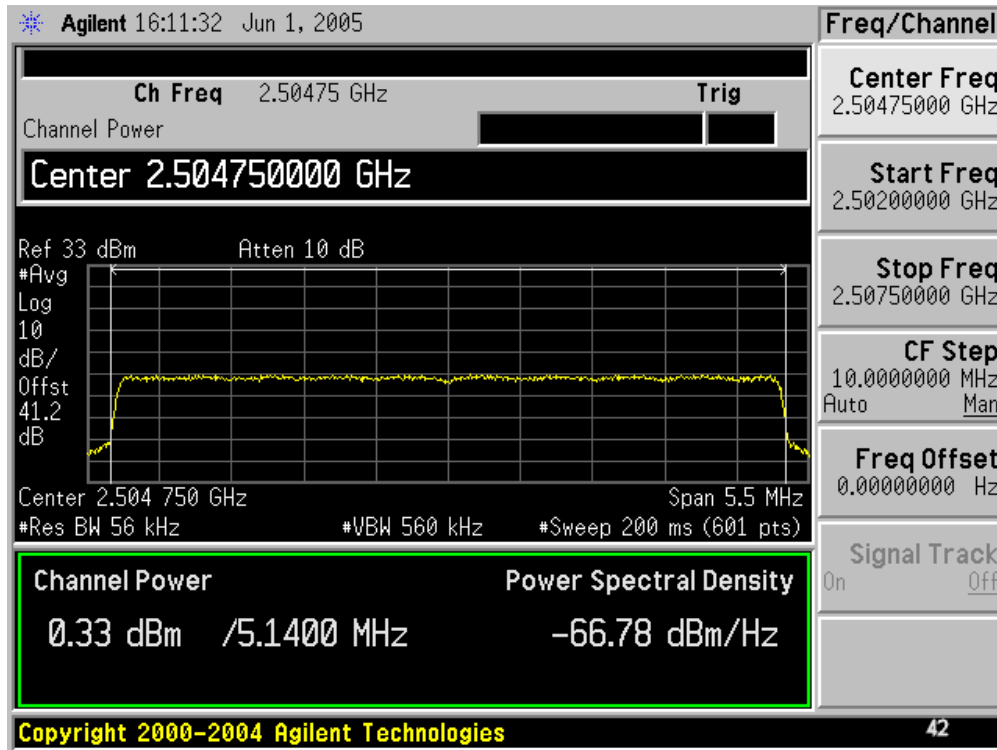

RF Power Output – Conducted (Minimum) 16-QAM (Cont'd)

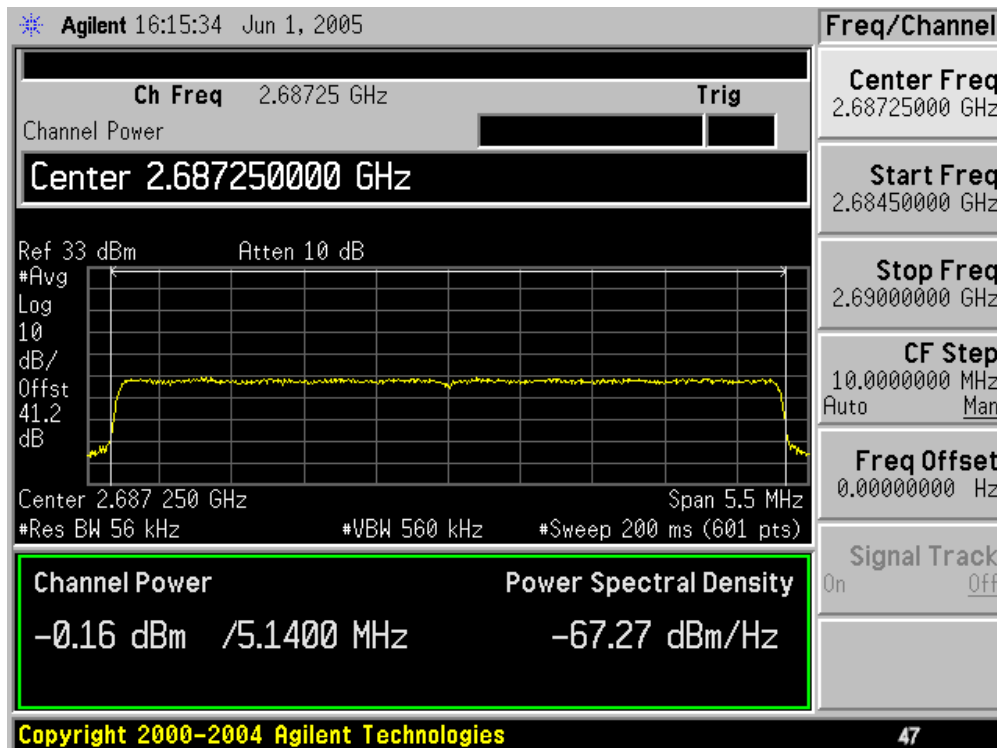
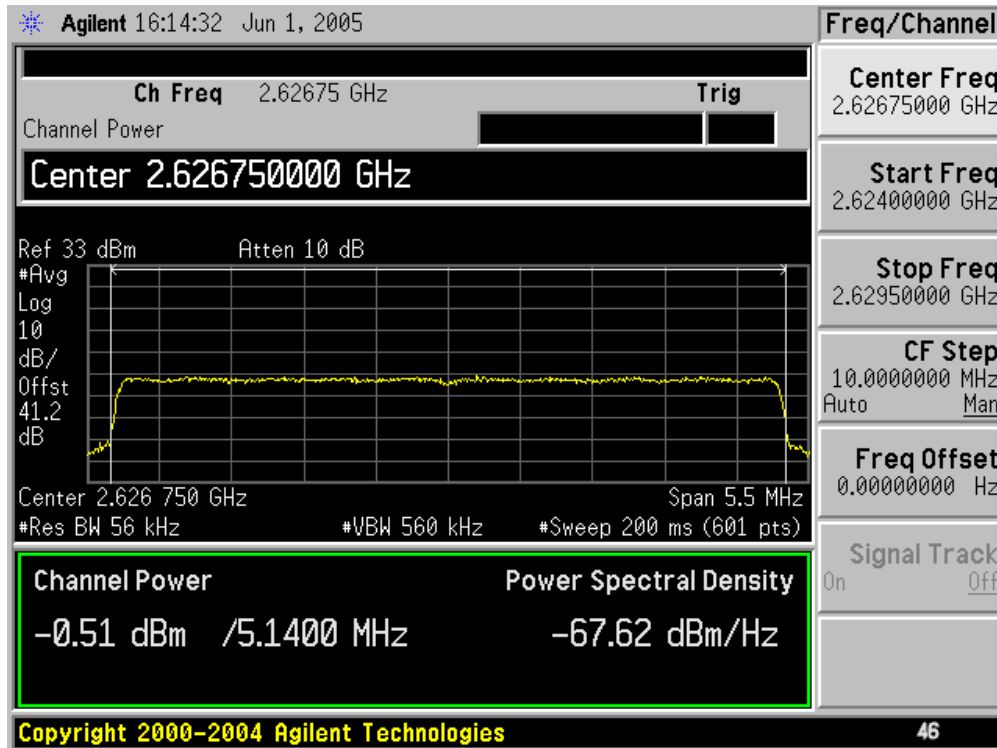

RF Power Output – Conducted (Minimum) 4-QAM (Cont'd)

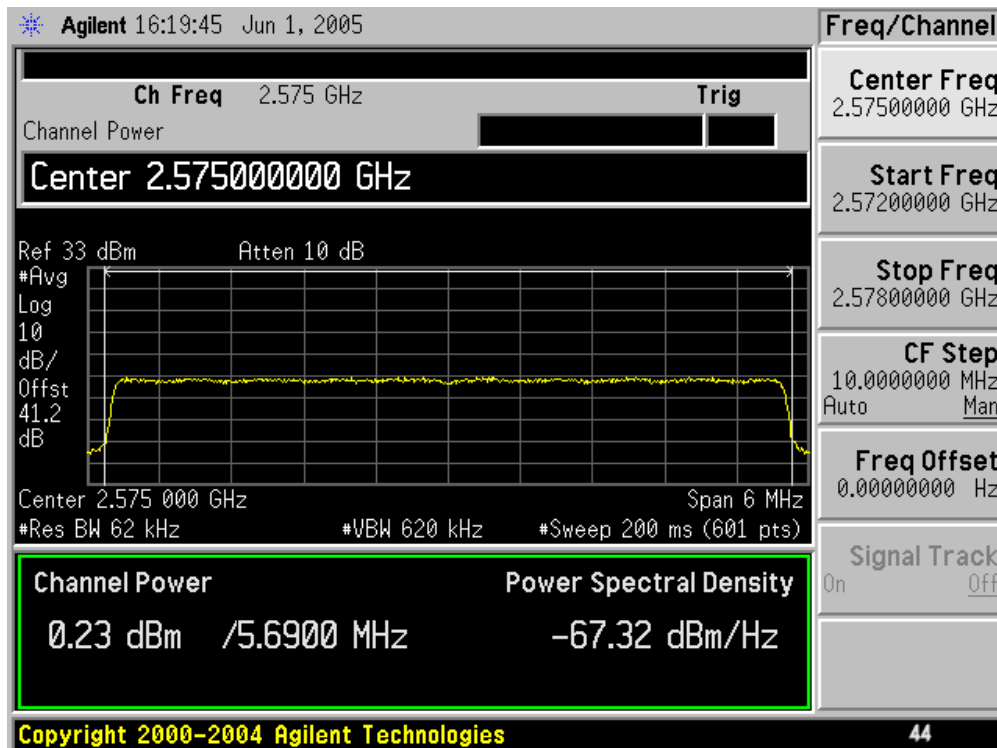
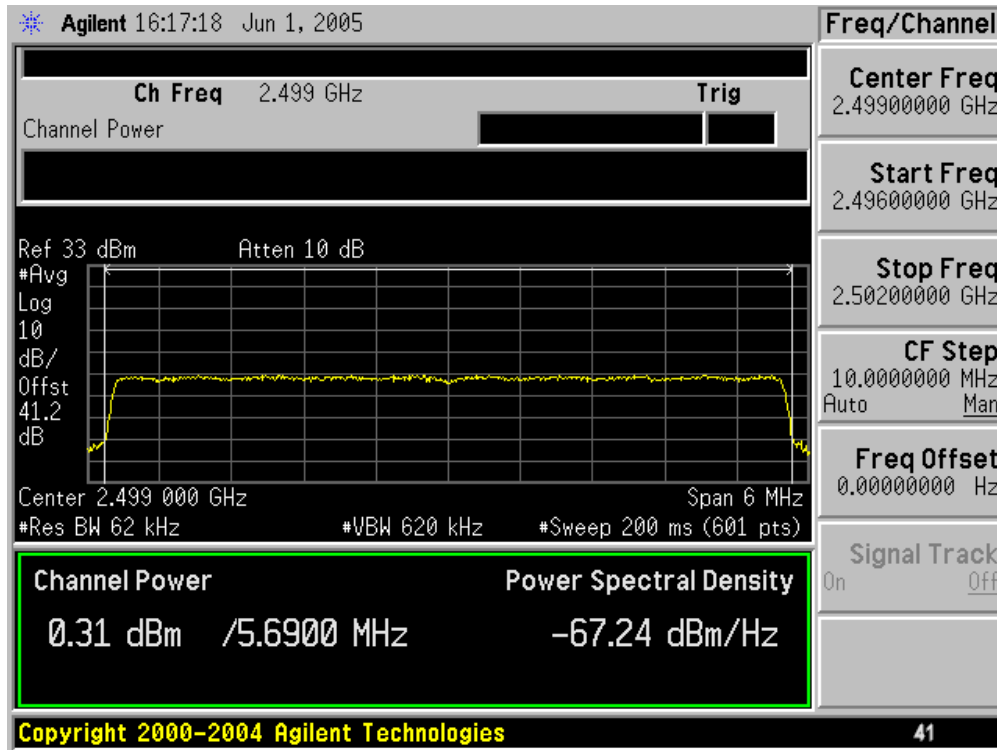

RF Power Output – Conducted (Minimum) 16-QAM (Cont'd)

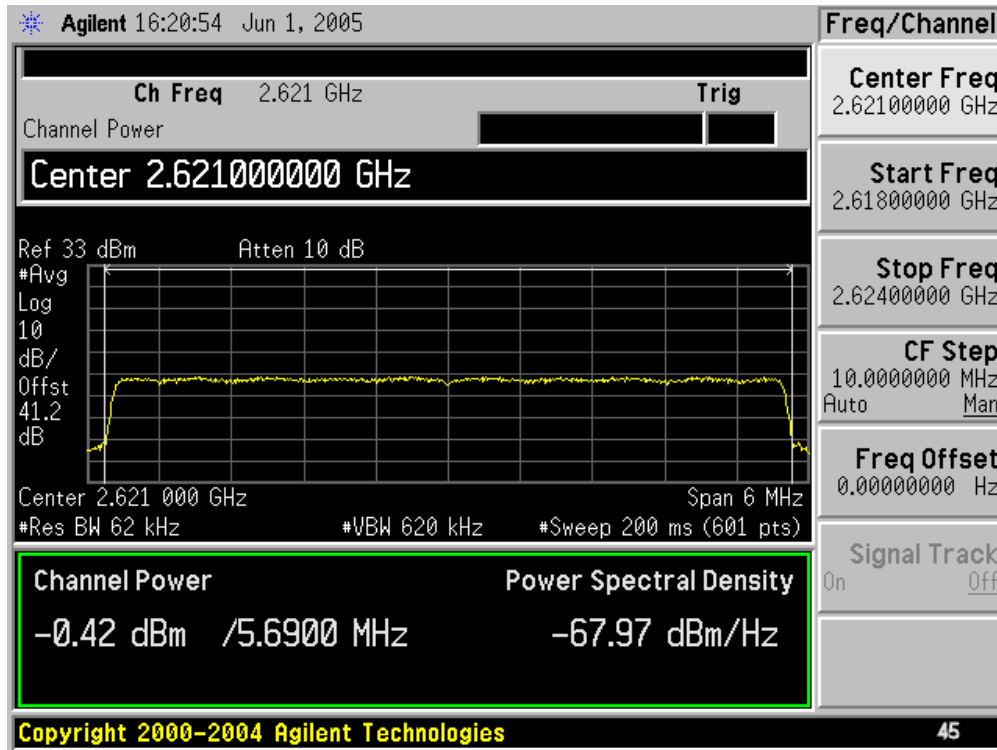

RF Power Output – Conducted (Minimum) 64-QAM

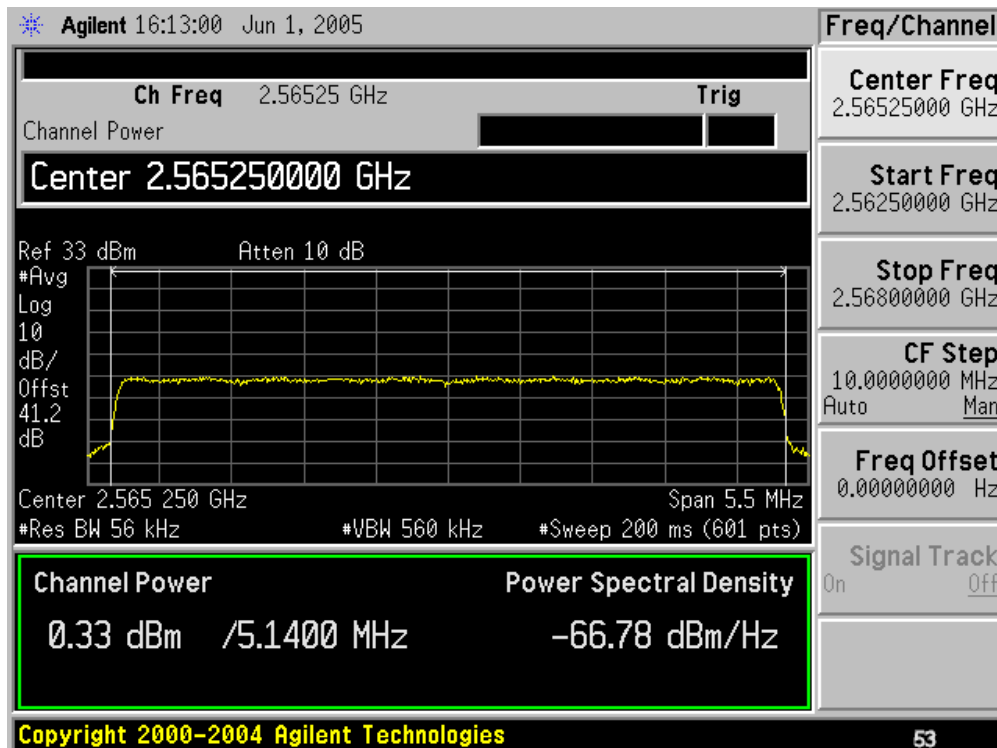
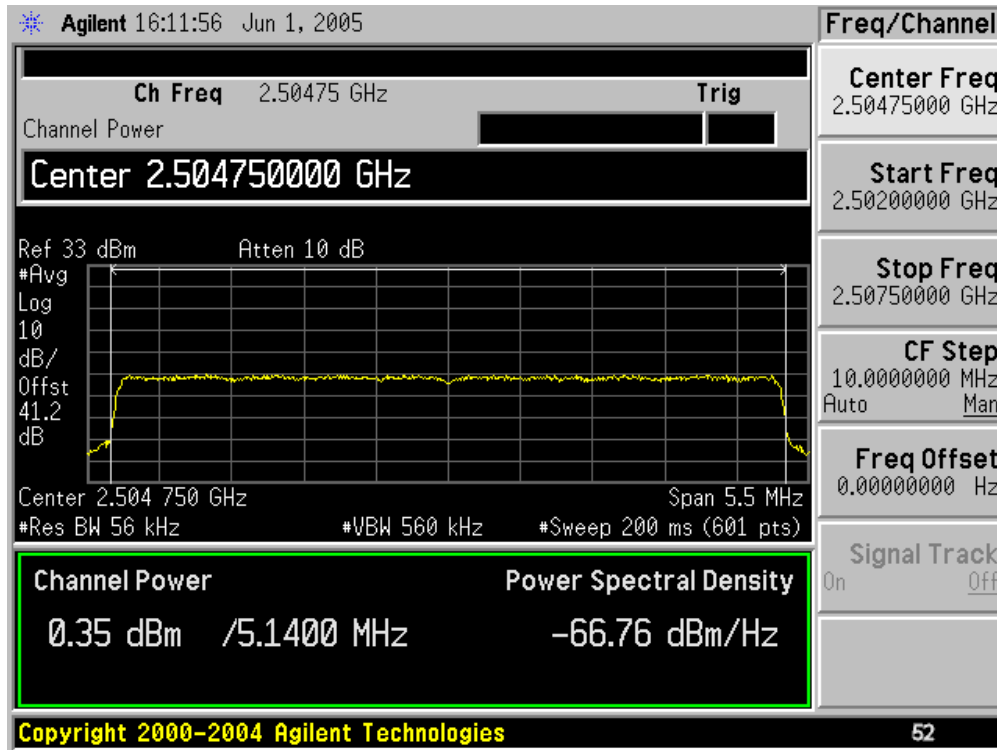

RF Power Output – Conducted (Minimum) 64-QAM (Cont'd)

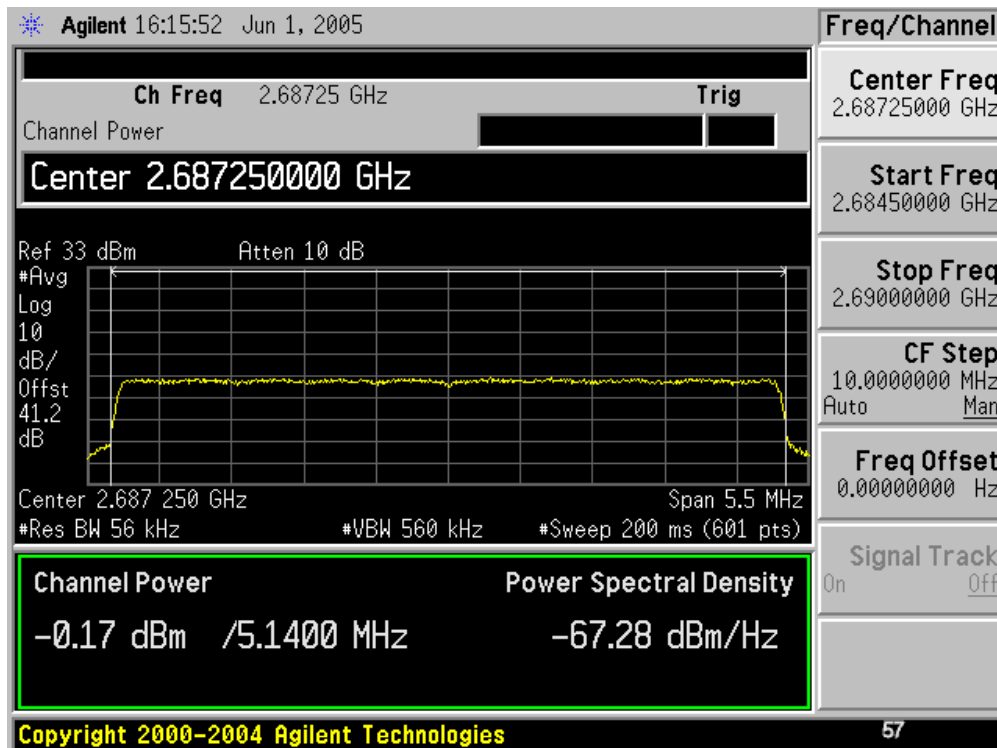
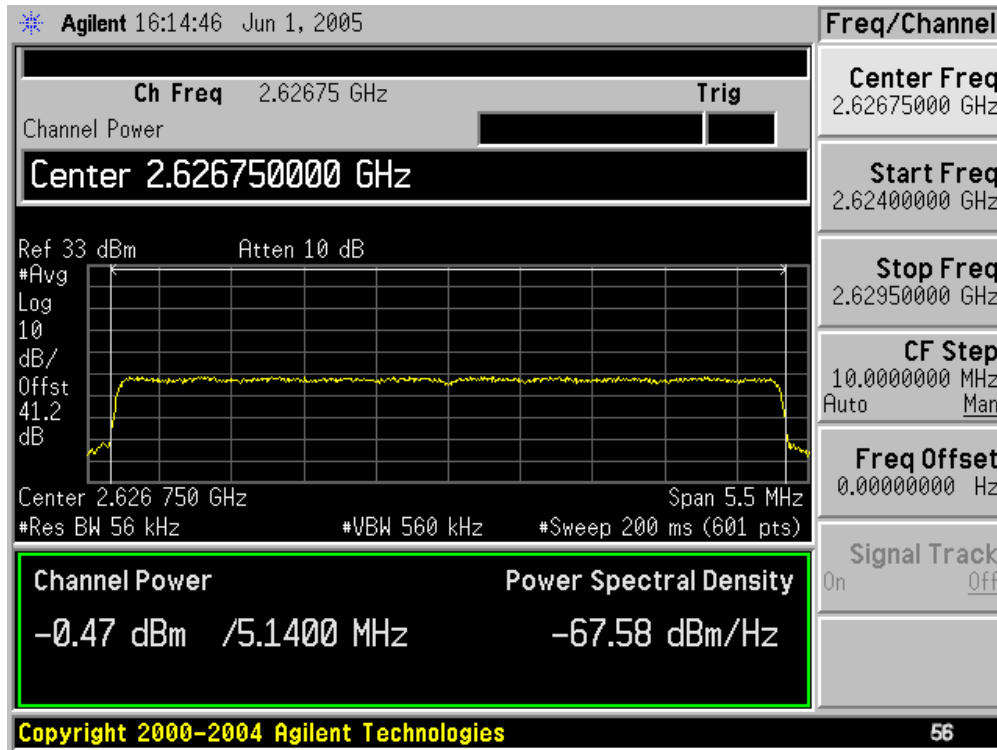

RF Power Output – Conducted (Minimum) 64-QAM (Cont'd)

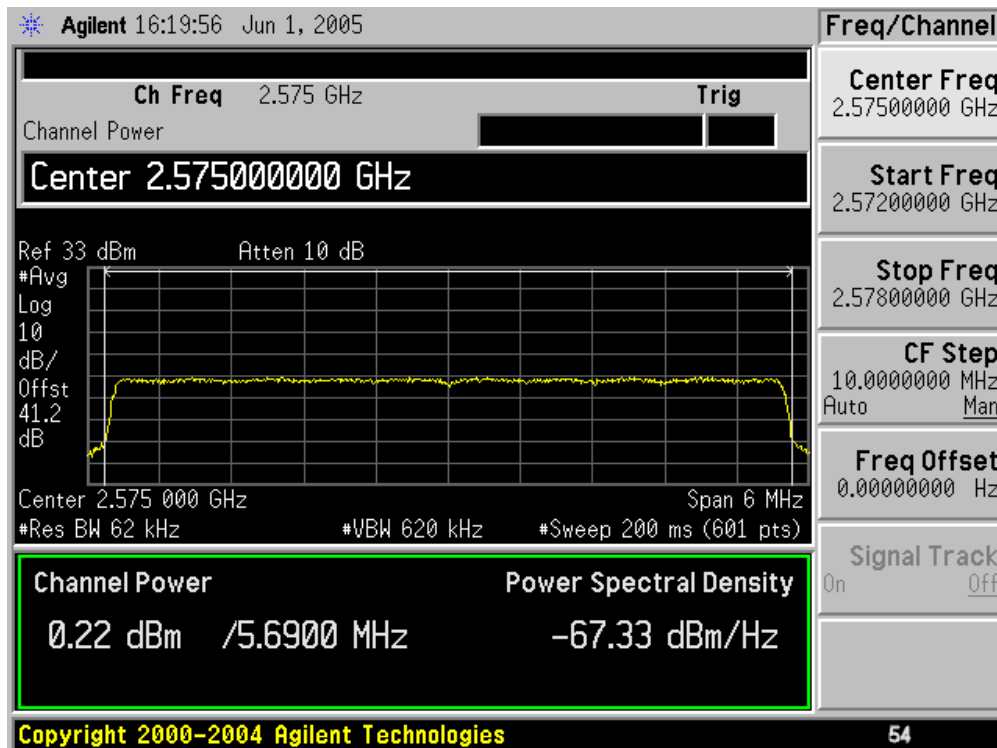
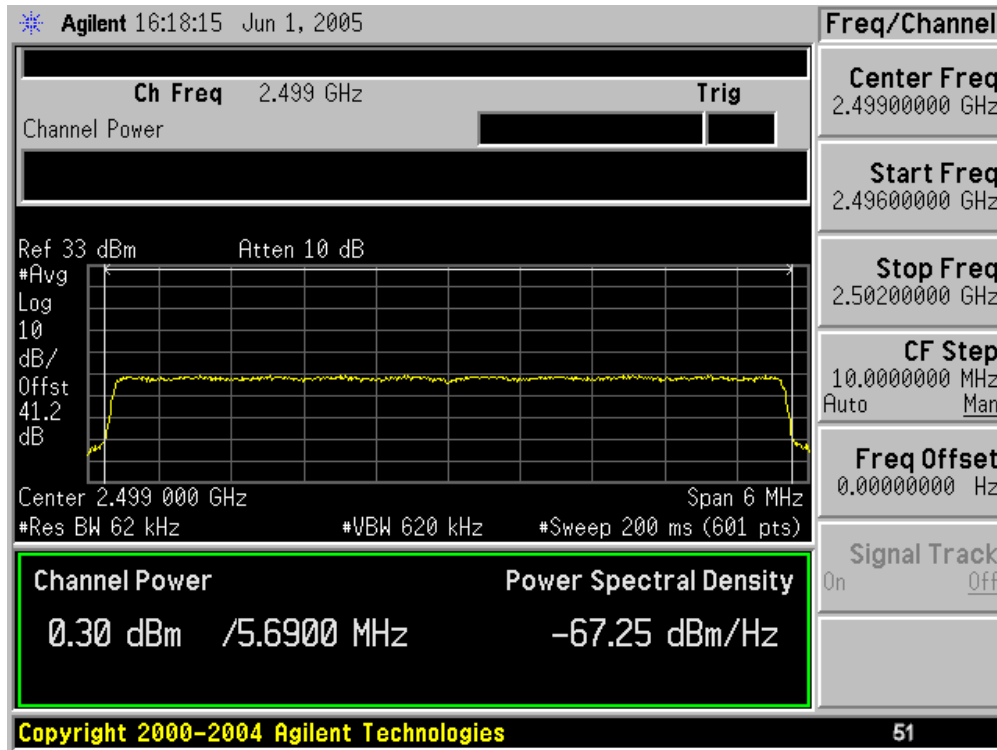

RF Power Output – Conducted (Minimum) 64-QAM (Cont'd)

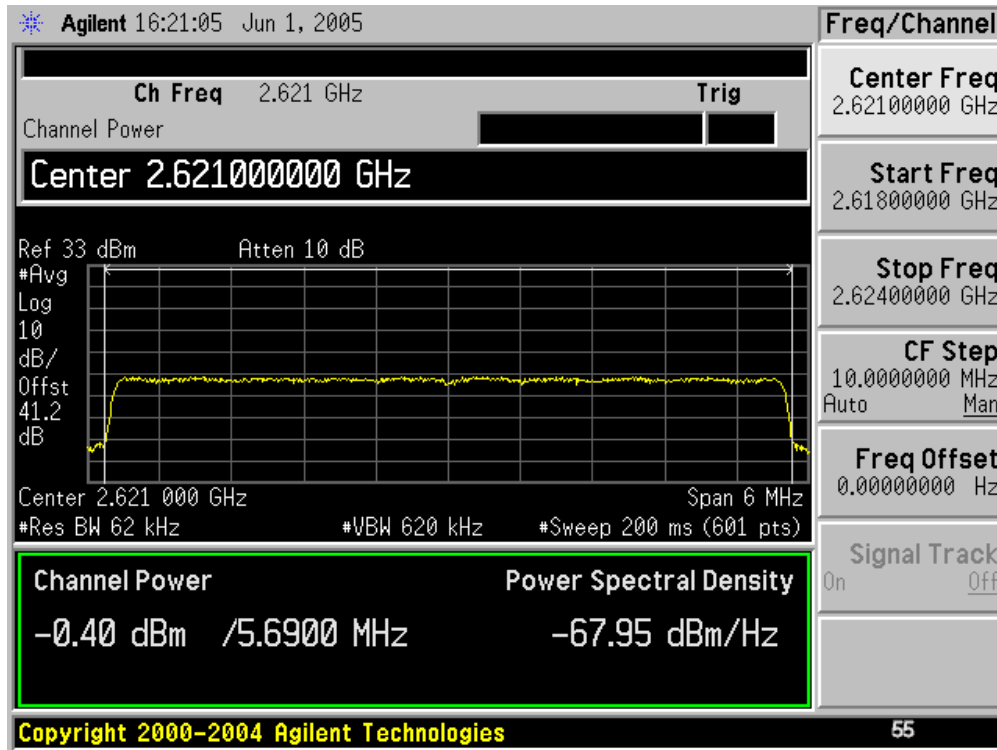

Modulation Characteristics

Rule Parts:

2.1047(d) *Other types of equipment.* A curve or equivalent data which shows that the equipment will meet the modulation requirements of the rules under which the equipment is to be licensed.

27.53(1)(2) (1) For BRS and EBS stations, the power of any emissions outside the licensee's frequency bands of operation shall be attenuated below the transmitter power (P) measured in watts.
(2) For fixed and temporary fixed digital stations, the attenuation shall be not less than $43 + 10 \log (P)$ dB

27.53(1)(6) Measurement procedure. Compliance with these rules is based on the use of measurement instrumentation employing a resolution bandwidth of 1 MHz or greater. However, in the 1 MHz bands immediately outside and adjacent to the frequency block a resolution bandwidth of at least one percent of the emission bandwidth of the fundamental emission of the transmitter may be employed. A narrower resolution bandwidth is permitted in all cases to improve measurement accuracy provided the measured power is integrated over the full required measurement bandwidth (i.e. 1 MHz or 1 percent of emission bandwidth, as specified). The emission bandwidth is defined as the width of the signal between two points, one below the carrier center frequency and one above the carrier center frequency, outside of which all emissions are attenuated at least 26 dB below the transmitter power.

Specifications: Attenuation at band edge = $43 + 10 \cdot \log(P)$, P= 2 watts
Attenuation at band edge = $43 + 10 \cdot \log(2) = 43 + 3$
Attenuation at band edge = 46 dB (equates to -13 dBm)

Compliance to the above requirements is verified by comparing the transmitter total power (P) to the integrated out of band power measured in 1 MHz bandwidths.

Standard: 47CFR27.53(1)(3)

Modulation Characteristics (Cont'd)

Test Procedure: The Orthogonal Frequency Division Multiplexing (OFDM) modulated Time Division Duplex (TDD) RF transmission from the test unit is applied to a spectrum analyzer. The Spectrum Analyzer is time gated to capture the transmission during the burst. An RMS detector is used to measure the average power of the transmission. The emission power is measured with the power measurement function in the spectrum analyzer. The resolution bandwidth is set to 1 MHz for emissions beyond the first 1 MHz of the band edge. For measurements within the 1 MHz of the band edge, the resolution bandwidth is adjusted to 56 kHz or 62 kHz depending on the channel bandwidth. The transmitter is enabled in test mode with the attached computer. The RF loss of the attenuators and coax was measured and is noted in the block diagram below. Measurements are performed at frequencies across the band, for each of the modulation formats available (4-, 16-, and 64-QAM) and channel bandwidths (5.5 MHz and 6.0 MHz). Spectrum analyzer plots for the 2499 MHz channel are included after the compiled data pages. All of the measurements on the other channels had similar results.

Test Conditions: Frequencies =
5.5 MHz channel: 2504.75, 2565.25, 2626.75, and 2687.25 MHz
6.0 MHz channel: 2499, 2575, and 2621 MHz
Temperature = 25 °C
Supply Voltage = 19.5 VDC nominal to RSU

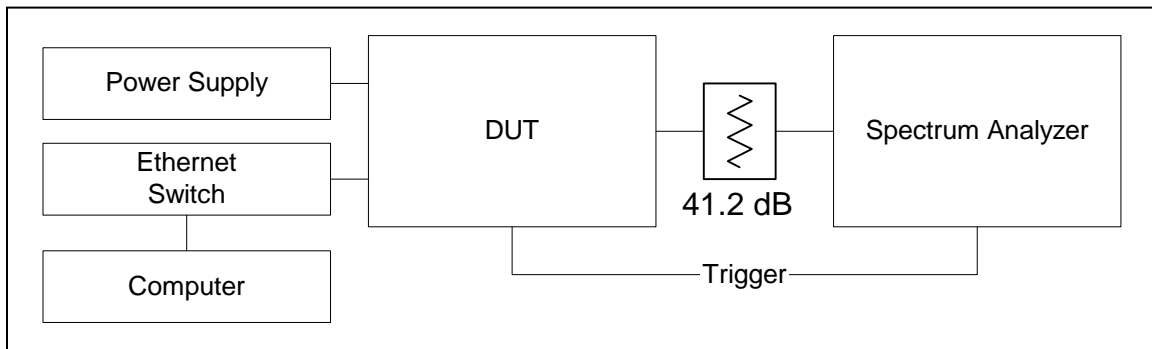

Modulation Characteristics Test Setup

Modulation Characteristics Test Results Summary:

Pass modulation characteristics across frequency band and modulation format.

Modulation Characteristics Test Results

2499 MHz, 6.0 MHz Channel, 4-QAM

	Channel Center Freq (MHz)		2499		6/3/2005			
	Channel BW (MHz)		6		19.5 VDC Nom			
	Channel Bandedge - Low (MHz)		2496		4-QAM			
	Channel Bandedge - High (MHz)		2502					
Resolution Bandwidth (kHz)		1 MHz Band Center Freq (MHz)	1 Mhz Band Low Freq (MHz)	1 MHz Band High Freq (MHz)	Emission Power in 1 MHz BW (dBm)	Spec (dBm/MHz)	Margin (dB)	Result
1000	- 6 MHz bin	2490.5	2490	2491	-41.14	-13	-28.14	Complies
1000	- 5 MHz bin	2491.5	2491	2492	-37.90	-13	-24.9	Complies
1000	- 4 MHz bin	2492.5	2492	2493	-33.99	-13	-20.99	Complies
1000	- 3 MHz bin	2493.5	2493	2494	-31.18	-13	-18.18	Complies
1000	- 2 MHz bin	2494.5	2494	2495	-16.05	-13	-3.05	Complies
62	- 2 MHz bin	2494.5	2494	2495	-28.89	-13	-15.89	Complies
62	- 1 MHz bin	2495.5	2495	2496	-23.48	-13	-10.48	Complies
62	+ 1 MHz bin	2502.5	2502	2503	-22.82	-13	-9.82	Complies
62	+ 2 MHz bin	2503.5	2503	2504	-29.02	-13	-16.02	Complies
1000	+ 2 MHz bin	2503.5	2503	2504	-15.26	-13	-2.26	Complies
1000	+ 3 MHz bin	2504.5	2504	2505	-31.57	-13	-18.57	Complies
1000	+ 4 MHz bin	2505.5	2505	2506	-34.61	-13	-21.61	Complies
1000	+ 5 MHz bin	2506.5	2506	2507	-38.48	-13	-25.48	Complies
1000	+ 6 MHz bin	2507.5	2507	2508	-41.40	-13	-28.4	Complies

2499 MHz, 6.0 MHz Channel, 16-QAM

	Channel Center Freq (MHz)		2499		6/3/2005			
	Channel BW (MHz)		6		19.5 VDC Nom			
	Channel Bandedge - Low (MHz)		2496		16-QAM			
	Channel Bandedge - High (MHz)		2502					
Resolution Bandwidth (kHz)		1 MHz Band Center Freq (MHz)	1 Mhz Band Low Freq (MHz)	1 MHz Band High Freq (MHz)	Emission Power in 1 MHz BW (dBm)	Spec (dBm/MHz)	Margin (dB)	Result
1000	- 6 MHz bin	2490.5	2490	2491	-41.23	-13	-28.23	Complies
1000	- 5 MHz bin	2491.5	2491	2492	-38.24	-13	-25.24	Complies
1000	- 4 MHz bin	2492.5	2492	2493	-34.41	-13	-21.41	Complies
1000	- 3 MHz bin	2493.5	2493	2494	-31.6	-13	-18.6	Complies
1000	- 2 MHz bin	2494.5	2494	2495	-16.19	-13	-3.19	Complies
62	- 2 MHz bin	2494.5	2494	2495	-29.26	-13	-16.26	Complies
62	- 1 MHz bin	2495.5	2495	2496	-23.52	-13	-10.52	Complies
62	+ 1 MHz bin	2502.5	2502	2503	-22.92	-13	-9.92	Complies
62	+ 2 MHz bin	2503.5	2503	2504	-29.05	-13	-16.05	Complies
1000	+ 2 MHz bin	2503.5	2503	2504	-15.25	-13	-2.25	Complies
1000	+ 3 MHz bin	2504.5	2504	2505	-31.57	-13	-18.57	Complies
1000	+ 4 MHz bin	2505.5	2505	2506	-34.62	-13	-21.62	Complies
1000	+ 5 MHz bin	2506.5	2506	2507	-38.46	-13	-25.46	Complies
1000	+ 6 MHz bin	2507.5	2507	2508	-41.39	-13	-28.39	Complies

Modulation Characteristics Test Results (Cont'd)

2499 MHz, 6.0 MHz Channel, 64-QAM

		Channel Center Freq (MHz)		2499	6/3/2005			
		Channel BW (MHz)		6	19.5 VDC Nom			
		Channel Bandedge - Low (MHz)		2496	64-QAM			
		Channel Bandedge - High (MHz)		2502				
Resolution Bandwidth (kHz)		1 MHz Band Center Freq (MHz)	1 Mhz Band Low Freq (MHz)	1 MHz Band High Freq (MHz)	Emission Power in 1 MHz BW (dBm)	Spec (dBm/MHz)	Margin (dB)	Result
1000	- 6 MHz bin	2490.5	2490	2491	-41.25	-13	-28.25	Complies
1000	- 5 MHz bin	2491.5	2491	2492	-38.21	-13	-25.21	Complies
1000	- 4 MHz bin	2492.5	2492	2493	-34.46	-13	-21.46	Complies
1000	- 3 MHz bin	2493.5	2493	2494	-31.63	-13	-18.63	Complies
1000	- 2 MHz bin	2494.5	2494	2495	-16.19	-13	-3.19	Complies
62	- 2 MHz bin	2494.5	2494	2495	-29.27	-13	-16.27	Complies
62	- 1 MHz bin	2495.5	2495	2496	-23.43	-13	-10.43	Complies
62	+ 1 MHz bin	2502.5	2502	2503	-22.96	-13	-9.96	Complies
62	+ 2 MHz bin	2503.5	2503	2504	-29.06	-13	-16.06	Complies
1000	+ 2 MHz bin	2503.5	2503	2504	-15.27	-13	-2.27	Complies
1000	+ 3 MHz bin	2504.5	2504	2505	-31.61	-13	-18.61	Complies
1000	+ 4 MHz bin	2505.5	2505	2506	-34.67	-13	-21.67	Complies
1000	+ 5 MHz bin	2506.5	2506	2507	-38.52	-13	-25.52	Complies
1000	+ 6 MHz bin	2507.5	2507	2508	-41.4	-13	-28.4	Complies

2504.750 MHz, 5.5 MHz Channel, 4-QAM

		Channel Center Freq (MHz)		2504.75	6/3/2005			
		Channel BW (MHz)		5.5	19.5 VDC Nom			
		Channel Bandedge - Low (MHz)		2502	4-QAM			
		Channel Bandedge - High (MHz)		2507.5				
Resolution Bandwidth (kHz)		1 MHz Band Center Freq (MHz)	1 Mhz Band Low Freq (MHz)	1 MHz Band High Freq (MHz)	Emission Power in 1 MHz BW (dBm)	Spec (dBm/MHz)	Margin (dB)	Result
1000	- 6 MHz bin	2496.5	2496	2497	-41.61	-13	-28.61	Complies
1000	- 5 MHz bin	2497.5	2497	2498	-39.95	-13	-26.95	Complies
1000	- 4 MHz bin	2498.5	2498	2499	-35.81	-13	-22.81	Complies
1000	- 3 MHz bin	2499.5	2499	2500	-32.32	-13	-19.32	Complies
1000	- 2 MHz bin	2500.5	2500	2501	-16.32	-13	-3.32	Complies
62	- 2 MHz bin	2500.5	2500	2501	-29.50	-13	-16.5	Complies
62	- 1 MHz bin	2501.5	2501	2502	-25.21	-13	-12.21	Complies
62	+ 1 MHz bin	2508	2507.5	2508.5	-24.68	-13	-11.68	Complies
62	+ 2 MHz bin	2509	2508.5	2509.5	-29.45	-13	-16.45	Complies
1000	+ 2 MHz bin	2509	2508.5	2509.5	-15.49	-13	-2.49	Complies
1000	+ 3 MHz bin	2510	2509.5	2510.5	-32.37	-13	-19.37	Complies
1000	+ 4 MHz bin	2511	2510.5	2511.5	-36.18	-13	-23.18	Complies
1000	+ 5 MHz bin	2512	2511.5	2512.5	-40.20	-13	-27.2	Complies
1000	+ 6 MHz bin	2513	2512.5	2513.5	-41.68	-13	-28.68	Complies

Modulation Characteristics Test Results (Cont'd)

2504.750 MHz, 5.5 MHz Channel, 16-QAM

		Channel Center Freq (MHz)			2504.75		6/3/2005		
		Channel BW (MHz)			5.5		19.5 VDC Nom		
		Channel Bandedge - Low (MHz)			2502		16-QAM		
		Channel Bandedge - High (MHz)			2507.5				
Resolution Bandwidth (kHz)		1 MHz Band Center Freq (MHz)	1 Mhz Band Low Freq (MHz)	1 MHz Band High Freq (MHz)	Emission Power in 1 MHz BW (dBm)	Spec (dBm/MHz)	Margin (dB)	Result	
1000	- 6 MHz bin	2496.5	2496	2497	-41.62	-13	-28.62	Complies	
1000	- 5 MHz bin	2497.5	2497	2498	-39.96	-13	-26.96	Complies	
1000	- 4 MHz bin	2498.5	2498	2499	-35.81	-13	-22.81	Complies	
1000	- 3 MHz bin	2499.5	2499	2500	-32.29	-13	-19.29	Complies	
1000	- 2 MHz bin	2500.5	2500	2501	-16.32	-13	-3.32	Complies	
62	- 2 MHz bin	2500.5	2500	2501	-29.48	-13	-16.48	Complies	
62	- 1 MHz bin	2501.5	2501	2502	-25.14	-13	-12.14	Complies	
62	+ 1 MHz bin	2508	2507.5	2508.5	-24.68	-13	-11.68	Complies	
62	+ 2 MHz bin	2509	2508.5	2509.5	-29.36	-13	-16.36	Complies	
1000	+ 2 MHz bin	2509	2508.5	2509.5	-15.47	-13	-2.47	Complies	
1000	+ 3 MHz bin	2510	2509.5	2510.5	-32.37	-13	-19.37	Complies	
1000	+ 4 MHz bin	2511	2510.5	2511.5	-36.21	-13	-23.21	Complies	
1000	+ 5 MHz bin	2512	2511.5	2512.5	-40.17	-13	-27.17	Complies	
1000	+ 6 MHz bin	2513	2512.5	2513.5	-41.69	-13	-28.69	Complies	

2504.750 MHz, 5.5 MHz Channel, 64-QAM

		Channel Center Freq (MHz)			2504.75		6/3/2005		
		Channel BW (MHz)			5.5		19.5 VDC Nom		
		Channel Bandedge - Low (MHz)			2502		64-QAM		
		Channel Bandedge - High (MHz)			2507.5				
Resolution Bandwidth (kHz)		1 MHz Band Center Freq (MHz)	1 Mhz Band Low Freq (MHz)	1 MHz Band High Freq (MHz)	Emission Power in 1 MHz BW (dBm)	Spec (dBm/MHz)	Margin (dB)	Result	
1000	- 6 MHz bin	2496.5	2496	2497	-41.62	-13	-28.62	Complies	
1000	- 5 MHz bin	2497.5	2497	2498	-39.97	-13	-26.97	Complies	
1000	- 4 MHz bin	2498.5	2498	2499	-35.8	-13	-22.8	Complies	
1000	- 3 MHz bin	2499.5	2499	2500	-32.29	-13	-19.29	Complies	
1000	- 2 MHz bin	2500.5	2500	2501	-16.35	-13	-3.35	Complies	
62	- 2 MHz bin	2500.5	2500	2501	-29.48	-13	-16.48	Complies	
62	- 1 MHz bin	2501.5	2501	2502	-25.24	-13	-12.24	Complies	
62	+ 1 MHz bin	2508	2507.5	2508.5	-24.51	-13	-11.51	Complies	
62	+ 2 MHz bin	2509	2508.5	2509.5	-29.39	-13	-16.39	Complies	
1000	+ 2 MHz bin	2509	2508.5	2509.5	-15.49	-13	-2.49	Complies	
1000	+ 3 MHz bin	2510	2509.5	2510.5	-32.38	-13	-19.38	Complies	
1000	+ 4 MHz bin	2511	2510.5	2511.5	-36.18	-13	-23.18	Complies	
1000	+ 5 MHz bin	2512	2511.5	2512.5	-40.21	-13	-27.21	Complies	
1000	+ 6 MHz bin	2513	2512.5	2513.5	-41.69	-13	-28.69	Complies	

Modulation Characteristics Test Results (Cont'd)

2565.250 MHz, 5.5 MHz Channel, 4-QAM

		Channel Center Freq (MHz)			2565.25	6/3/2005		
		Channel BW (MHz)			5.5	19.5 VDC Nom		
		Channel Bandedge - Low (MHz)			2562.5	4-QAM		
		Channel Bandedge - High (MHz)			2568			
Resolution Bandwidth (kHz)		1 MHz Band Center Freq (MHz)	1 Mhz Band Low Freq (MHz)	1 MHz Band High Freq (MHz)	Emission Power in 1 MHz BW (dBm)	Spec (dBm/MHz)	Margin (dB)	Result
1000	- 6 MHz bin	2557	2556.5	2557.5	-41.70	-13	-28.7	Complies
1000	- 5 MHz bin	2558	2557.5	2558.5	-40.52	-13	-27.52	Complies
1000	- 4 MHz bin	2559	2558.5	2559.5	-37.10	-13	-24.1	Complies
1000	- 3 MHz bin	2560	2559.5	2560.5	-33.75	-13	-20.75	Complies
1000	- 2 MHz bin	2561	2560.5	2561.5	-16.44	-13	-3.44	Complies
62	- 2 MHz bin	2561	2560.5	2561.5	-30.74	-13	-17.74	Complies
62	- 1 MHz bin	2562	2561.5	2562.5	-25.82	-13	-12.82	Complies
62	+ 1 MHz bin	2568.5	2568	2569	-25.46	-13	-12.46	Complies
62	+ 2 MHz bin	2569.5	2569	2570	-30.63	-13	-17.63	Complies
1000	+ 2 MHz bin	2569.5	2569	2570	-15.65	-13	-2.65	Complies
1000	+ 3 MHz bin	2570.5	2570	2571	-33.78	-13	-20.78	Complies
1000	+ 4 MHz bin	2571.5	2571	2572	-37.36	-13	-24.36	Complies
1000	+ 5 MHz bin	2572.5	2572	2573	-40.71	-13	-27.71	Complies
1000	+ 6 MHz bin	2573.5	2573	2574	-41.80	-13	-28.8	Complies

2565.250 MHz, 5.5 MHz Channel, 16-QAM

		Channel Center Freq (MHz)			2565.25	6/3/2005		
		Channel BW (MHz)			5.5	19.5 VDC Nom		
		Channel Bandedge - Low (MHz)			2562.5	16-QAM		
		Channel Bandedge - High (MHz)			2568			
Resolution Bandwidth (kHz)		1 MHz Band Center Freq (MHz)	1 Mhz Band Low Freq (MHz)	1 MHz Band High Freq (MHz)	Emission Power in 1 MHz BW (dBm)	Spec (dBm/MHz)	Margin (dB)	Result
1000	- 6 MHz bin	2557	2556.5	2557.5	-41.70	-13	-28.7	Complies
1000	- 5 MHz bin	2558	2557.5	2558.5	-40.51	-13	-27.51	Complies
1000	- 4 MHz bin	2559	2558.5	2559.5	-37.12	-13	-24.12	Complies
1000	- 3 MHz bin	2560	2559.5	2560.5	-33.80	-13	-20.8	Complies
1000	- 2 MHz bin	2561	2560.5	2561.5	-16.44	-13	-3.44	Complies
62	- 2 MHz bin	2561	2560.5	2561.5	-30.74	-13	-17.74	Complies
62	- 1 MHz bin	2562	2561.5	2562.5	-25.74	-13	-12.74	Complies
62	+ 1 MHz bin	2568.5	2568	2569	-25.78	-13	-12.78	Complies
62	+ 2 MHz bin	2569.5	2569	2570	-30.71	-13	-17.71	Complies
1000	+ 2 MHz bin	2569.5	2569	2570	-15.65	-13	-2.65	Complies
1000	+ 3 MHz bin	2570.5	2570	2571	-33.79	-13	-20.79	Complies
1000	+ 4 MHz bin	2571.5	2571	2572	-37.36	-13	-24.36	Complies
1000	+ 5 MHz bin	2572.5	2572	2573	-40.72	-13	-27.72	Complies
1000	+ 6 MHz bin	2573.5	2573	2574	-41.80	-13	-28.8	Complies

Modulation Characteristics Test Results (Cont'd)

2565.250 MHz, 5.5 MHz Channel, 64-QAM

		Channel Center Freq (MHz)		2565.25	6/3/2005			
		Channel BW (MHz)		5.5	19.5 VDC Nom			
		Channel Bandedge - Low (MHz)		2562.5	64-QAM			
		Channel Bandedge - High (MHz)		2568				
Resolution Bandwidth (kHz)		1 MHz Band Center Freq (MHz)	1 Mhz Band Low Freq (MHz)	1 MHz Band High Freq (MHz)	Emission Power in 1 MHz BW (dBm)	Spec (dBm/MHz)	Margin (dB)	Result
1000	- 6 MHz bin	2557	2556.5	2557.5	-41.69	-13	-28.69	Complies
1000	- 5 MHz bin	2558	2557.5	2558.5	-40.50	-13	-27.5	Complies
1000	- 4 MHz bin	2559	2558.5	2559.5	-37.10	-13	-24.1	Complies
1000	- 3 MHz bin	2560	2559.5	2560.5	-33.76	-13	-20.76	Complies
1000	- 2 MHz bin	2561	2560.5	2561.5	-16.44	-13	-3.44	Complies
62	- 2 MHz bin	2561	2560.5	2561.5	-30.69	-13	-17.69	Complies
62	- 1 MHz bin	2562	2561.5	2562.5	-25.77	-13	-12.77	Complies
62	+ 1 MHz bin	2568.5	2568	2569	-25.27	-13	-12.27	Complies
62	+ 2 MHz bin	2569.5	2569	2570	-30.65	-13	-17.65	Complies
1000	+ 2 MHz bin	2569.5	2569	2570	-15.65	-13	-2.65	Complies
1000	+ 3 MHz bin	2570.5	2570	2571	-33.75	-13	-20.75	Complies
1000	+ 4 MHz bin	2571.5	2571	2572	-37.33	-13	-24.33	Complies
1000	+ 5 MHz bin	2572.5	2572	2573	-40.72	-13	-27.72	Complies
1000	+ 6 MHz bin	2573.5	2573	2574	-41.80	-13	-28.8	Complies

2575 MHz, 6.0 MHz Channel, 4-QAM

		Channel Center Freq (MHz)		2575	6/3/2005			
		Channel BW (MHz)		6	19.5 VDC Nom			
		Channel Bandedge - Low (MHz)		2572	4-QAM			
		Channel Bandedge - High (MHz)		2578				
Resolution Bandwidth (kHz)		1 MHz Band Center Freq (MHz)	1 Mhz Band Low Freq (MHz)	1 MHz Band High Freq (MHz)	Emission Power in 1 MHz BW (dBm)	Spec (dBm/MHz)	Margin (dB)	Result
1000	- 6 MHz bin	2566.5	2566	2567	-41.54	-13	-28.54	Complies
1000	- 5 MHz bin	2567.5	2567	2568	-39.50	-13	-26.5	Complies
1000	- 4 MHz bin	2568.5	2568	2569	-36.36	-13	-23.36	Complies
1000	- 3 MHz bin	2569.5	2569	2570	-33.67	-13	-20.67	Complies
1000	- 2 MHz bin	2570.5	2570	2571	-16.39	-13	-3.39	Complies
62	- 2 MHz bin	2570.5	2570	2571	-31.09	-13	-18.09	Complies
62	- 1 MHz bin	2571.5	2571	2572	-23.92	-13	-10.92	Complies
62	+ 1 MHz bin	2578.5	2578	2579	-23.83	-13	-10.83	Complies
62	+ 2 MHz bin	2579.5	2579	2580	-31.08	-13	-18.08	Complies
1000	+ 2 MHz bin	2579.5	2579	2580	-15.54	-13	-2.54	Complies
1000	+ 3 MHz bin	2580.5	2580	2581	-33.66	-13	-20.66	Complies
1000	+ 4 MHz bin	2581.5	2581	2582	-36.57	-13	-23.57	Complies
1000	+ 5 MHz bin	2582.5	2582	2583	-39.67	-13	-26.67	Complies
1000	+ 6 MHz bin	2583.5	2583	2584	-41.61	-13	-28.61	Complies

Modulation Characteristics Test Results (Cont'd)

2575 MHz, 6.0 MHz Channel, 16-QAM

		Channel Center Freq (MHz)		2575		6/3/2005		
		Channel BW (MHz)		6		19.5 VDC Nom		
		Channel Bandedge - Low (MHz)		2572		16-QAM		
		Channel Bandedge - High (MHz)		2578				
Resolution Bandwidth (kHz)		1 MHz Band Center Freq (MHz)	1 Mhz Band Low Freq (MHz)	1 MHz Band High Freq (MHz)	Emission Power in 1 MHz BW (dBm)	Spec (dBm/MHz)	Margin (dB)	Result
1000	- 6 MHz bin	2566.5	2566	2567	-41.53	-13	-28.53	Complies
1000	- 5 MHz bin	2567.5	2567	2568	-39.47	-13	-26.47	Complies
1000	- 4 MHz bin	2568.5	2568	2569	-36.38	-13	-23.38	Complies
1000	- 3 MHz bin	2569.5	2569	2570	-33.70	-13	-20.7	Complies
1000	- 2 MHz bin	2570.5	2570	2571	-16.38	-13	-3.38	Complies
62	- 2 MHz bin	2570.5	2570	2571	-31.08	-13	-18.08	Complies
62	- 1 MHz bin	2571.5	2571	2572	-23.77	-13	-10.77	Complies
62	+ 1 MHz bin	2578.5	2578	2579	-23.71	-13	-10.71	Complies
62	+ 2 MHz bin	2579.5	2579	2580	-31.11	-13	-18.11	Complies
1000	+ 2 MHz bin	2579.5	2579	2580	-15.54	-13	-2.54	Complies
1000	+ 3 MHz bin	2580.5	2580	2581	-33.68	-13	-20.68	Complies
1000	+ 4 MHz bin	2581.5	2581	2582	-36.55	-13	-23.55	Complies
1000	+ 5 MHz bin	2582.5	2582	2583	-39.67	-13	-26.67	Complies
1000	+ 6 MHz bin	2583.5	2583	2584	-41.61	-13	-28.61	Complies

2575 MHz, 6.0 MHz Channel, 64-QAM

		Channel Center Freq (MHz)		2575		6/3/2005		
		Channel BW (MHz)		6		19.5 VDC Nom		
		Channel Bandedge - Low (MHz)		2572		64-QAM		
		Channel Bandedge - High (MHz)		2578				
Resolution Bandwidth (kHz)		1 MHz Band Center Freq (MHz)	1 Mhz Band Low Freq (MHz)	1 MHz Band High Freq (MHz)	Emission Power in 1 MHz BW (dBm)	Spec (dBm/MHz)	Margin (dB)	Result
1000	- 6 MHz bin	2566.5	2566	2567	-41.50	-13	-28.5	Complies
1000	- 5 MHz bin	2567.5	2567	2568	-39.47	-13	-26.47	Complies
1000	- 4 MHz bin	2568.5	2568	2569	-36.36	-13	-23.36	Complies
1000	- 3 MHz bin	2569.5	2569	2570	-33.65	-13	-20.65	Complies
1000	- 2 MHz bin	2570.5	2570	2571	-16.35	-13	-3.35	Complies
62	- 2 MHz bin	2570.5	2570	2571	-31.08	-13	-18.08	Complies
62	- 1 MHz bin	2571.5	2571	2572	-24.14	-13	-11.14	Complies
62	+ 1 MHz bin	2578.5	2578	2579	-23.88	-13	-10.88	Complies
62	+ 2 MHz bin	2579.5	2579	2580	-31.07	-13	-18.07	Complies
1000	+ 2 MHz bin	2579.5	2579	2580	-15.53	-13	-2.53	Complies
1000	+ 3 MHz bin	2580.5	2580	2581	-33.66	-13	-20.66	Complies
1000	+ 4 MHz bin	2581.5	2581	2582	-36.56	-13	-23.56	Complies
1000	+ 5 MHz bin	2582.5	2582	2583	-39.67	-13	-26.67	Complies
1000	+ 6 MHz bin	2583.5	2583	2584	-41.61	-13	-28.61	Complies

Modulation Characteristics Test Results (Cont'd)

2621 MHz, 6.0 MHz Channel, 4-QAM

		Channel Center Freq (MHz)		2621		6/3/2005		
		Channel BW (MHz)		6		19.5 VDC Nom		
		Channel Bandedge - Low (MHz)		2618		4-QAM		
		Channel Bandedge - High (MHz)		2624				
Resolution Bandwidth (kHz)		1 MHz Band Center Freq (MHz)	1 Mhz Band Low Freq (MHz)	1 MHz Band High Freq (MHz)	Emission Power in 1 MHz BW (dBm)	Spec (dBm/MHz)	Margin (dB)	Result
1000	- 6 MHz bin	2612.5	2612	2613	-40.81	-13	-27.81	Complies
1000	- 5 MHz bin	2613.5	2613	2614	-37.82	-13	-24.82	Complies
1000	- 4 MHz bin	2614.5	2614	2615	-34.22	-13	-21.22	Complies
1000	- 3 MHz bin	2615.5	2615	2616	-31.53	-13	-18.53	Complies
1000	- 2 MHz bin	2616.5	2616	2617	-15.30	-13	-2.3	Complies
62	- 2 MHz bin	2616.5	2616	2617	-29.06	-13	-16.06	Complies
62	- 1 MHz bin	2617.5	2617	2618	-23.04	-13	-10.04	Complies
62	+ 1 MHz bin	2624.5	2624	2625	-23.15	-13	-10.15	Complies
62	+ 2 MHz bin	2625.5	2625	2626	-30.46	-13	-17.46	Complies
1000	+ 2 MHz bin	2625.5	2625	2626	-14.74	-13	-1.74	Complies
1000	+ 3 MHz bin	2626.5	2626	2627	-33.01	-13	-20.01	Complies
1000	+ 4 MHz bin	2627.5	2627	2628	-35.95	-13	-22.95	Complies
1000	+ 5 MHz bin	2628.5	2628	2629	-39.26	-13	-26.26	Complies
1000	+ 6 MHz bin	2629.5	2629	2630	-41.50	-13	-28.5	Complies

2621 MHz, 6.0 MHz Channel, 16-QAM

		Channel Center Freq (MHz)		2621		6/3/2005		
		Channel BW (MHz)		6		19.5 VDC Nom		
		Channel Bandedge - Low (MHz)		2618		16-QAM		
		Channel Bandedge - High (MHz)		2624				
Resolution Bandwidth (kHz)		1 MHz Band Center Freq (MHz)	1 Mhz Band Low Freq (MHz)	1 MHz Band High Freq (MHz)	Emission Power in 1 MHz BW (dBm)	Spec (dBm/MHz)	Margin (dB)	Result
1000	- 6 MHz bin	2612.5	2612	2613	-41.40	-13	-28.4	Complies
1000	- 5 MHz bin	2613.5	2613	2614	-39.84	-13	-26.84	Complies
1000	- 4 MHz bin	2614.5	2614	2615	-36.22	-13	-23.22	Complies
1000	- 3 MHz bin	2615.5	2615	2616	-32.93	-13	-19.93	Complies
1000	- 2 MHz bin	2616.5	2616	2617	-15.74	-13	-2.74	Complies
62	- 2 MHz bin	2616.5	2616	2617	-30.05	-13	-17.05	Complies
62	- 1 MHz bin	2617.5	2617	2618	-25.23	-13	-12.23	Complies
62	+ 1 MHz bin	2624.5	2624	2625	-25.33	-13	-12.33	Complies
62	+ 2 MHz bin	2625.5	2625	2626	-30.96	-13	-17.96	Complies
1000	+ 2 MHz bin	2625.5	2625	2626	-15.18	-13	-2.18	Complies
1000	+ 3 MHz bin	2626.5	2626	2627	-33.92	-13	-20.92	Complies
1000	+ 4 MHz bin	2627.5	2627	2628	-37.42	-13	-24.42	Complies
1000	+ 5 MHz bin	2628.5	2628	2629	-40.57	-13	-27.57	Complies
1000	+ 6 MHz bin	2629.5	2629	2630	-41.54	-13	-28.54	Complies

Modulation Characteristics Test Results (Cont'd)

2621 MHz, 6.0 MHz Channel, 64-QAM

		Channel Center Freq (MHz)		2621	6/3/2005			
		Channel BW (MHz)		6	19.5 VDC Nom			
		Channel Bandedge - Low (MHz)		2618	64-QAM			
		Channel Bandedge - High (MHz)		2624				
Resolution Bandwidth (kHz)		1 MHz Band Center Freq (MHz)	1 Mhz Band Low Freq (MHz)	1 MHz Band High Freq (MHz)	Emission Power in 1 MHz BW (dBm)	Spec (dBm/MHz)	Margin (dB)	Result
1000	- 6 MHz bin	2612.5	2612	2613	-41.38	-13	-28.38	Complies
1000	- 5 MHz bin	2613.5	2613	2614	-39.88	-13	-26.88	Complies
1000	- 4 MHz bin	2614.5	2614	2615	-36.22	-13	-23.22	Complies
1000	- 3 MHz bin	2615.5	2615	2616	-32.93	-13	-19.93	Complies
1000	- 2 MHz bin	2616.5	2616	2617	-15.78	-13	-2.78	Complies
62	- 2 MHz bin	2616.5	2616	2617	-30.06	-13	-17.06	Complies
62	- 1 MHz bin	2617.5	2617	2618	-25.14	-13	-12.14	Complies
62	+ 1 MHz bin	2624.5	2624	2625	-25.36	-13	-12.36	Complies
62	+ 2 MHz bin	2625.5	2625	2626	-30.98	-13	-17.98	Complies
1000	+ 2 MHz bin	2625.5	2625	2626	-15.20	-13	-2.2	Complies
1000	+ 3 MHz bin	2626.5	2626	2627	-41.67	-13	-28.67	Complies
1000	+ 4 MHz bin	2627.5	2627	2628	-37.46	-13	-24.46	Complies
1000	+ 5 MHz bin	2628.5	2628	2629	-41.51	-13	-28.51	Complies
1000	+ 6 MHz bin	2629.5	2629	2630	-41.54	-13	-28.54	Complies

2626.750 MHz, 5.5 MHz Channel, 4-QAM

		Channel Center Freq (MHz)		2626.75	6/3/2005			
		Channel BW (MHz)		5.5	19.5 VDC Nom			
		Channel Bandedge - Low (MHz)		2624	4-QAM			
		Channel Bandedge - High (MHz)		2629.5				
Resolution Bandwidth (kHz)		1 MHz Band Center Freq (MHz)	1 Mhz Band Low Freq (MHz)	1 MHz Band High Freq (MHz)	Emission Power in 1 MHz BW (dBm)	Spec (dBm/MHz)	Margin (dB)	Result
1000	- 6 MHz bin	2618.5	2618	2619	-41.38	-13	-28.38	Complies
1000	- 5 MHz bin	2619.5	2619	2620	-39.87	-13	-26.87	Complies
1000	- 4 MHz bin	2620.5	2620	2621	-36.24	-13	-23.24	Complies
1000	- 3 MHz bin	2621.5	2621	2622	-32.94	-13	-19.94	Complies
1000	- 2 MHz bin	2622.5	2622	2623	-15.78	-13	-2.78	Complies
62	- 2 MHz bin	2622.5	2622	2623	-30.35	-13	-17.35	Complies
62	- 1 MHz bin	2623.5	2623	2624	-24.97	-13	-11.97	Complies
62	+ 1 MHz bin	2630	2629.5	2630.5	-25.35	-13	-12.35	Complies
62	+ 2 MHz bin	2631	2630.5	2631.5	-31.00	-13	-18	Complies
1000	+ 2 MHz bin	2631	2630.5	2631.5	-15.21	-13	-2.21	Complies
1000	+ 3 MHz bin	2632	2631.5	2632.5	-33.97	-13	-20.97	Complies
1000	+ 4 MHz bin	2633	2632.5	2633.5	-37.42	-13	-24.42	Complies
1000	+ 5 MHz bin	2634	2633.5	2634.5	-40.56	-13	-27.56	Complies
1000	+ 6 MHz bin	2635	2634.5	2635.5	-41.54	-13	-28.54	Complies

Modulation Characteristics Test Results (Cont'd)

2626.750 MHz, 5.5 MHz Channel, 16-QAM

		Channel Center Freq (MHz)			2626.75		6/3/2005		
		Channel BW (MHz)			5.5		19.5 VDC Nom		
		Channel Bandedge - Low (MHz)			2624		16-QAM		
		Channel Bandedge - High (MHz)			2629.5				
Resolution Bandwidth (kHz)		1 MHz Band Center Freq (MHz)	1 Mhz Band Low Freq (MHz)	1 MHz Band High Freq (MHz)	Emission Power in 1 MHz BW (dBm)	Spec (dBm/MHz)	Margin (dB)	Result	
1000	- 6 MHz bin	2618.5	2618	2619	-41.40	-13	-28.4	Complies	
1000	- 5 MHz bin	2619.5	2619	2620	-39.84	-13	-26.84	Complies	
1000	- 4 MHz bin	2620.5	2620	2621	-36.22	-13	-23.22	Complies	
1000	- 3 MHz bin	2621.5	2621	2622	-32.93	-13	-19.93	Complies	
1000	- 2 MHz bin	2622.5	2622	2623	-15.74	-13	-2.74	Complies	
62	- 2 MHz bin	2622.5	2622	2623	-30.05	-13	-17.05	Complies	
62	- 1 MHz bin	2623.5	2623	2624	-25.23	-13	-12.23	Complies	
62	+ 1 MHz bin	2630	2629.5	2630.5	-25.33	-13	-12.33	Complies	
62	+ 2 MHz bin	2631	2630.5	2631.5	-30.96	-13	-17.96	Complies	
1000	+ 2 MHz bin	2631	2630.5	2631.5	-15.18	-13	-2.18	Complies	
1000	+ 3 MHz bin	2632	2631.5	2632.5	-33.92	-13	-20.92	Complies	
1000	+ 4 MHz bin	2633	2632.5	2633.5	-37.42	-13	-24.42	Complies	
1000	+ 5 MHz bin	2634	2633.5	2634.5	-40.57	-13	-27.57	Complies	
1000	+ 6 MHz bin	2635	2634.5	2635.5	-41.54	-13	-28.54	Complies	

2626.750 MHz, 5.5 MHz Channel, 64-QAM

		Channel Center Freq (MHz)			2626.75		6/3/2005		
		Channel BW (MHz)			5.5		19.5 VDC Nom		
		Channel Bandedge - Low (MHz)			2624		64-QAM		
		Channel Bandedge - High (MHz)			2629.5				
Resolution Bandwidth (kHz)		1 MHz Band Center Freq (MHz)	1 Mhz Band Low Freq (MHz)	1 MHz Band High Freq (MHz)	Emission Power in 1 MHz BW (dBm)	Spec (dBm/MHz)	Margin (dB)	Result	
1000	- 6 MHz bin	2618.5	2618	2619	-41.38	-13	-28.38	Complies	
1000	- 5 MHz bin	2619.5	2619	2620	-39.88	-13	-26.88	Complies	
1000	- 4 MHz bin	2620.5	2620	2621	-36.22	-13	-23.22	Complies	
1000	- 3 MHz bin	2621.5	2621	2622	-32.93	-13	-19.93	Complies	
1000	- 2 MHz bin	2622.5	2622	2623	-15.78	-13	-2.78	Complies	
62	- 2 MHz bin	2622.5	2622	2623	-30.06	-13	-17.06	Complies	
62	- 1 MHz bin	2623.5	2623	2624	-25.14	-13	-12.14	Complies	
62	+ 1 MHz bin	2630	2629.5	2630.5	-25.36	-13	-12.36	Complies	
62	+ 2 MHz bin	2631	2630.5	2631.5	-30.98	-13	-17.98	Complies	
1000	+ 2 MHz bin	2631	2630.5	2631.5	-15.20	-13	-2.2	Complies	
1000	+ 3 MHz bin	2632	2631.5	2632.5	-41.67	-13	-28.67	Complies	
1000	+ 4 MHz bin	2633	2632.5	2633.5	-37.46	-13	-24.46	Complies	
1000	+ 5 MHz bin	2634	2633.5	2634.5	-41.51	-13	-28.51	Complies	
1000	+ 6 MHz bin	2635	2634.5	2635.5	-41.54	-13	-28.54	Complies	

Modulation Characteristics Test Results (Cont'd)

2687.250 MHz, 5.5 MHz Channel, 4-QAM

		Channel Center Freq (MHz)			2687.25		6/3/2005		
		Channel BW (MHz)			5.5		19.5 VDC Nom		
		Channel Bandedge - Low (MHz)			2684.5		4-QAM		
		Channel Bandedge - High (MHz)			2690				
Resolution Bandwidth (kHz)		1 MHz Band Center Freq (MHz)	1 Mhz Band Low Freq (MHz)	1 MHz Band High Freq (MHz)	Emission Power in 1 MHz BW (dBm)	Spec (dBm/MHz)	Margin (dB)	Result	
1000	- 6 MHz bin	2679	2678.5	2679.5	-41.44	-13	-28.44	Complies	
1000	- 5 MHz bin	2680	2679.5	2680.5	-40.33	-13	-27.33	Complies	
1000	- 4 MHz bin	2681	2680.5	2681.5	-37.31	-13	-24.31	Complies	
1000	- 3 MHz bin	2682	2681.5	2682.5	-34.25	-13	-21.25	Complies	
1000	- 2 MHz bin	2683	2682.5	2683.5	-16.11	-13	-3.11	Complies	
62	- 2 MHz bin	2683	2682.5	2683.5	-31.47	-13	-18.47	Complies	
62	- 1 MHz bin	2684	2683.5	2684.5	-25.96	-13	-12.96	Complies	
62	+ 1 MHz bin	2690.5	2690	2691	-26.39	-13	-13.39	Complies	
62	+ 2 MHz bin	2691.5	2691	2692	-32.77	-13	-19.77	Complies	
1000	+ 2 MHz bin	2691.5	2691	2692	-15.34	-13	-2.34	Complies	
1000	+ 3 MHz bin	2692.5	2692	2693	-35.57	-13	-22.57	Complies	
1000	+ 4 MHz bin	2693.5	2693	2694	-38.64	-13	-25.64	Complies	
1000	+ 5 MHz bin	2694.5	2694	2695	-40.88	-13	-27.88	Complies	
1000	+ 6 MHz bin	2695.5	2695	2696	-41.55	-13	-28.55	Complies	

2687.250 MHz, 5.5 MHz Channel, 16-QAM

		Channel Center Freq (MHz)			2687.25		6/3/2005		
		Channel BW (MHz)			5.5		19.5 VDC Nom		
		Channel Bandedge - Low (MHz)			2684.5		16-QAM		
		Channel Bandedge - High (MHz)			2690				
Resolution Bandwidth (kHz)		1 MHz Band Center Freq (MHz)	1 Mhz Band Low Freq (MHz)	1 MHz Band High Freq (MHz)	Emission Power in 1 MHz BW (dBm)	Spec (dBm/MHz)	Margin (dB)	Result	
1000	- 6 MHz bin	2679	2678.5	2679.5	-41.43	-13	-28.43	Complies	
1000	- 5 MHz bin	2680	2679.5	2680.5	-40.32	-13	-27.32	Complies	
1000	- 4 MHz bin	2681	2680.5	2681.5	-41.66	-13	-28.66	Complies	
1000	- 3 MHz bin	2682	2681.5	2682.5	-34.23	-13	-21.23	Complies	
1000	- 2 MHz bin	2683	2682.5	2683.5	-16.07	-13	-3.07	Complies	
62	- 2 MHz bin	2683	2682.5	2683.5	-31.46	-13	-18.46	Complies	
62	- 1 MHz bin	2684	2683.5	2684.5	-25.92	-13	-12.92	Complies	
62	+ 1 MHz bin	2690.5	2690	2691	-26.32	-13	-13.32	Complies	
62	+ 2 MHz bin	2691.5	2691	2692	-32.72	-13	-19.72	Complies	
1000	+ 2 MHz bin	2691.5	2691	2692	-15.34	-13	-2.34	Complies	
1000	+ 3 MHz bin	2692.5	2692	2693	-35.56	-13	-22.56	Complies	
1000	+ 4 MHz bin	2693.5	2693	2694	-38.62	-13	-25.62	Complies	
1000	+ 5 MHz bin	2694.5	2694	2695	-40.89	-13	-27.89	Complies	
1000	+ 6 MHz bin	2695.5	2695	2696	-41.56	-13	-28.56	Complies	

Modulation Characteristics Test Results (Cont'd)

2687.250 MHz, 5.5 MHz Channel, 64-QAM

		Channel Center Freq (MHz)			2687.25	6/3/2005		
		Channel BW (MHz)			5.5	19.5 VDC Nom		
		Channel Bandedge - Low (MHz)			2684.5	64-QAM		
		Channel Bandedge - High (MHz)			2690			
Resolution Bandwidth (kHz)		1 MHz Band Center Freq (MHz)	1 Mhz Band Low Freq (MHz)	1 MHz Band High Freq (MHz)	Emission Power in 1 MHz BW (dBm)	Spec (dBm/MHz)	Margin (dB)	Result
1000	- 6 MHz bin	2679	2678.5	2679.5	-41.43	-13	-28.43	Complies
1000	- 5 MHz bin	2680	2679.5	2680.5	-40.34	-13	-27.34	Complies
1000	- 4 MHz bin	2681	2680.5	2681.5	-37.32	-13	-24.32	Complies
1000	- 3 MHz bin	2682	2681.5	2682.5	-34.27	-13	-21.27	Complies
1000	- 2 MHz bin	2683	2682.5	2683.5	-16.10	-13	-3.1	Complies
62	- 2 MHz bin	2683	2682.5	2683.5	-31.39	-13	-18.39	Complies
62	- 1 MHz bin	2684	2683.5	2684.5	-25.90	-13	-12.9	Complies
62	+ 1 MHz bin	2690.5	2690	2691	-26.37	-13	-13.37	Complies
62	+ 2 MHz bin	2691.5	2691	2692	-32.74	-13	-19.74	Complies
1000	+ 2 MHz bin	2691.5	2691	2692	-15.35	-13	-2.35	Complies
1000	+ 3 MHz bin	2692.5	2692	2693	-35.56	-13	-22.56	Complies
1000	+ 4 MHz bin	2693.5	2693	2694	-38.62	-13	-25.62	Complies
1000	+ 5 MHz bin	2694.5	2694	2695	-40.88	-13	-27.88	Complies
1000	+ 6 MHz bin	2695.5	2695	2696	-41.55	-13	-28.55	Complies

Modulation Characteristics Spectrum Analyzer Plots

Emissions measurements for F=2499 MHz, 6.0 MHz channel, 4-QAM

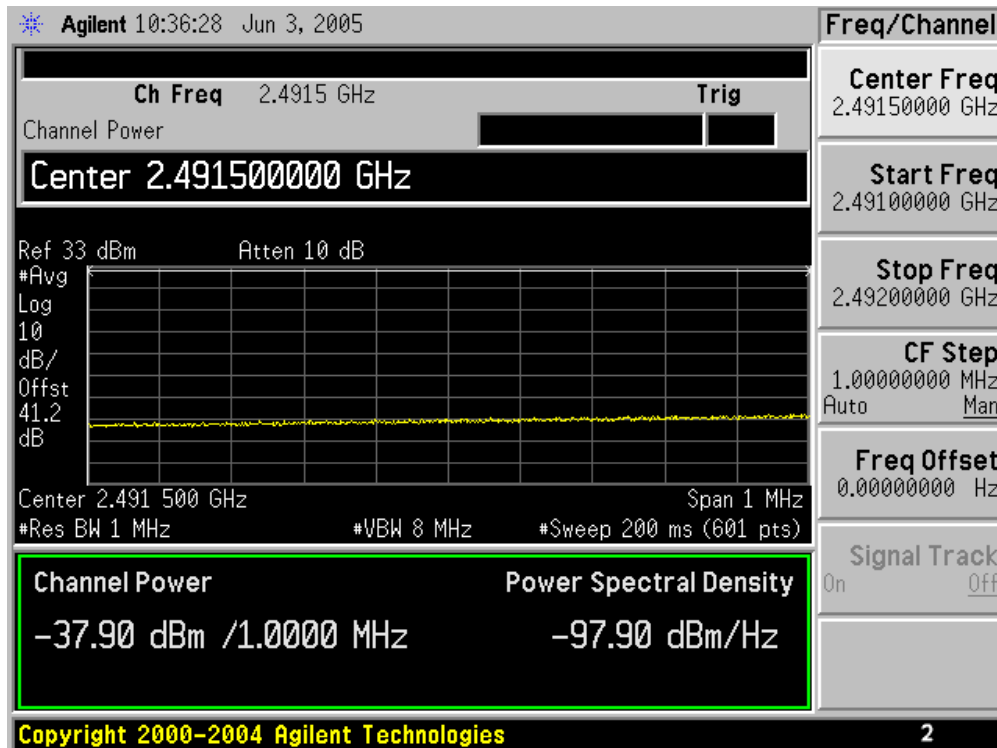
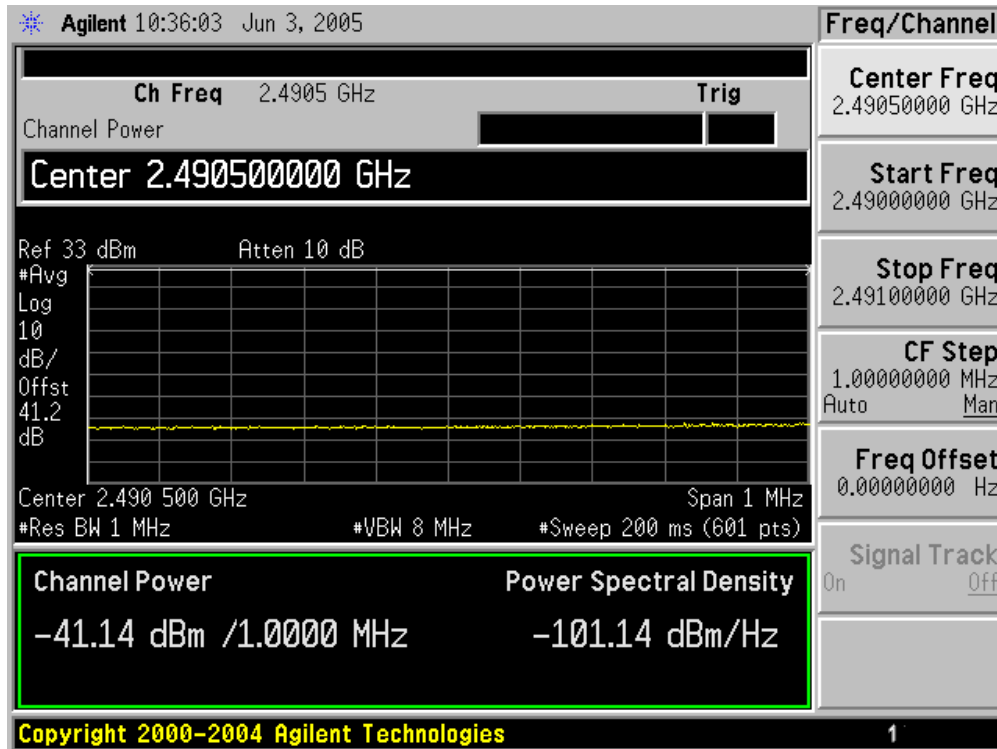

Modulation Characteristics Plots (Cont'd)

Emissions measurements for F=2499 MHz, 6.0 MHz channel, 4-QAM (Cont'd)

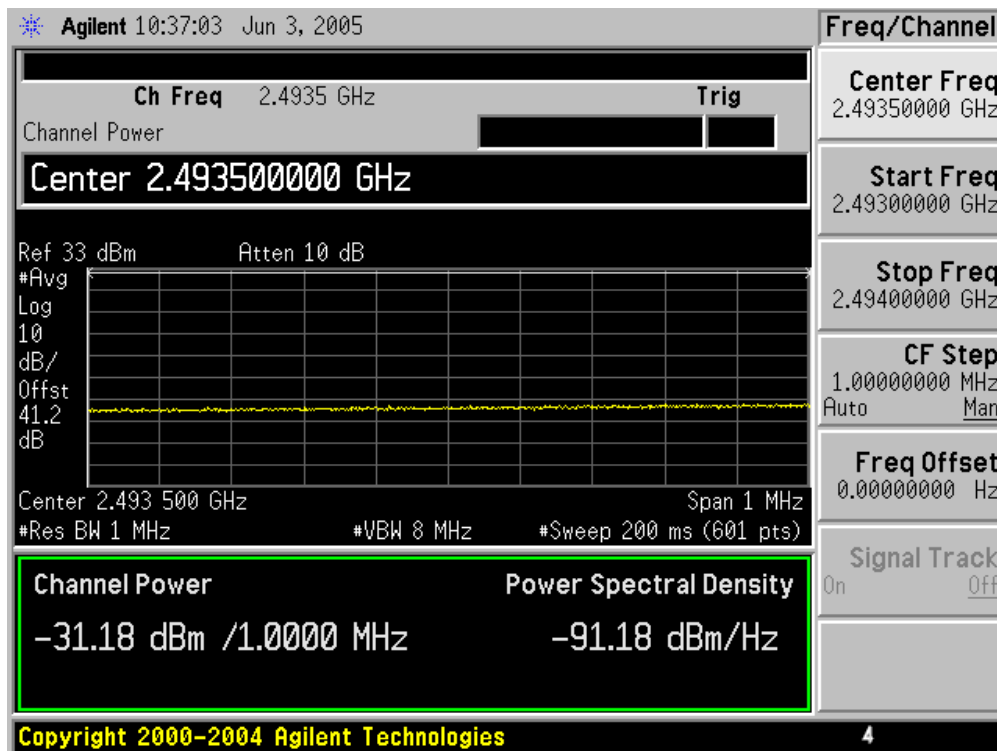
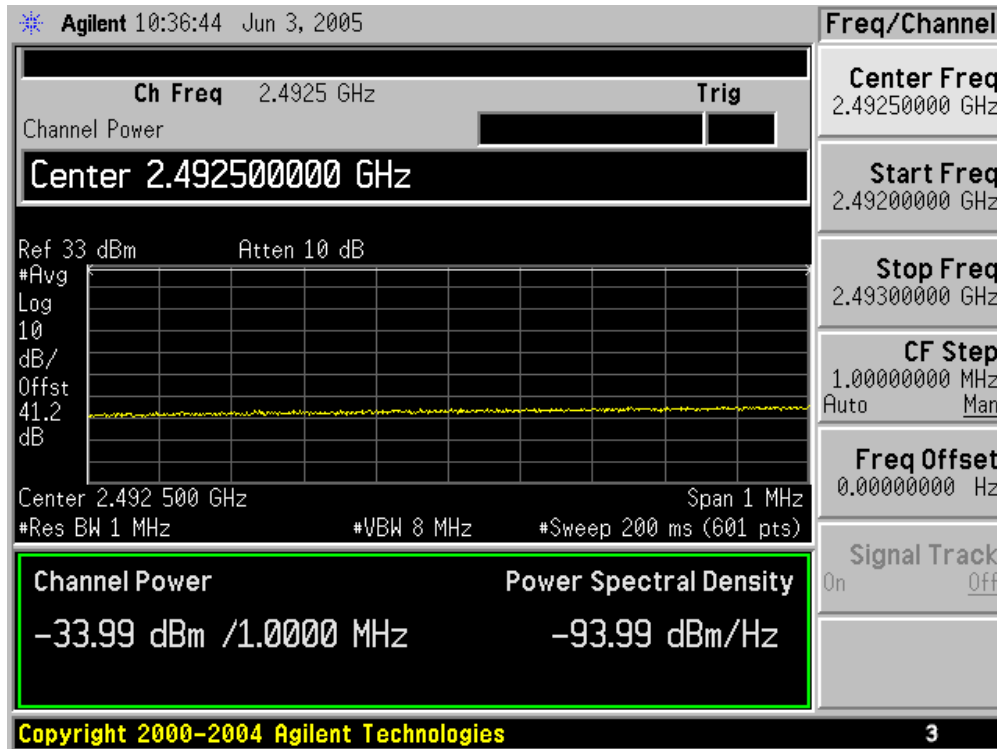

Modulation Characteristics Plots (Cont'd)

Emissions measurements for F=2499 MHz, 6.0 MHz channel, 4-QAM (Cont'd)

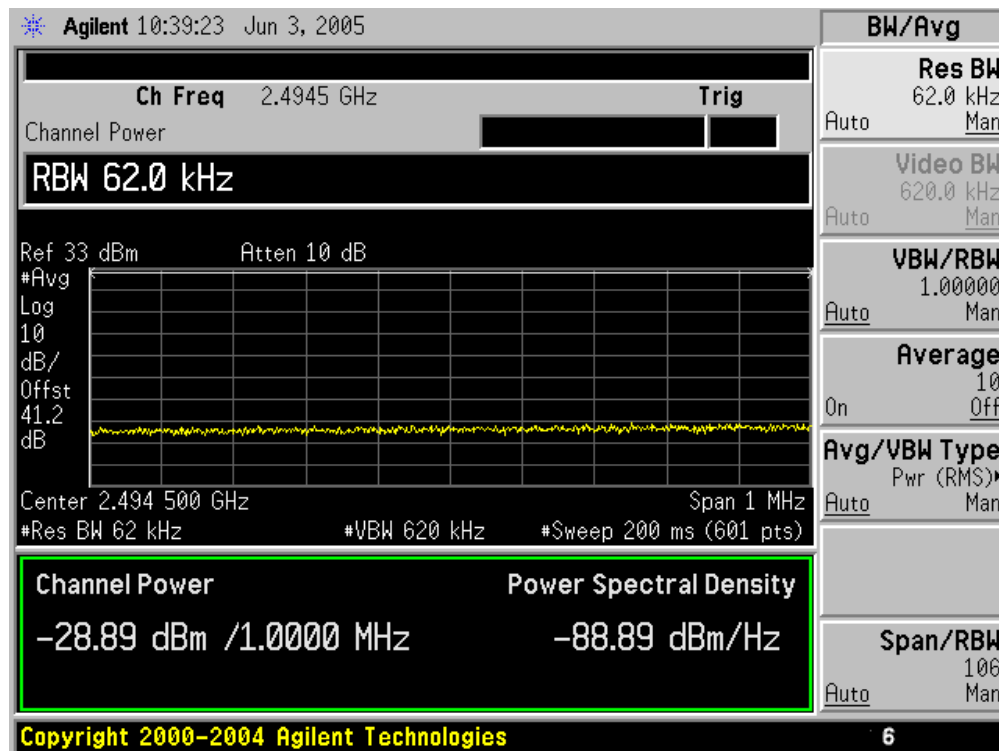
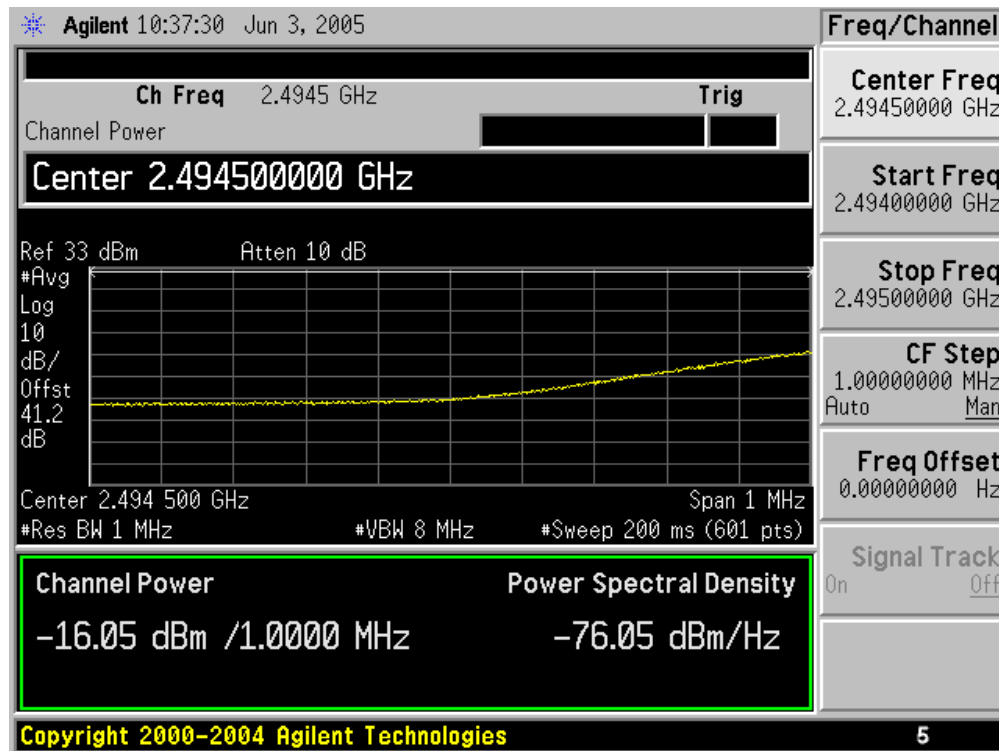

Modulation Characteristics Plots (Cont'd)

Emissions measurements for F=2499 MHz, 6.0 MHz channel, 4-QAM (Cont'd)

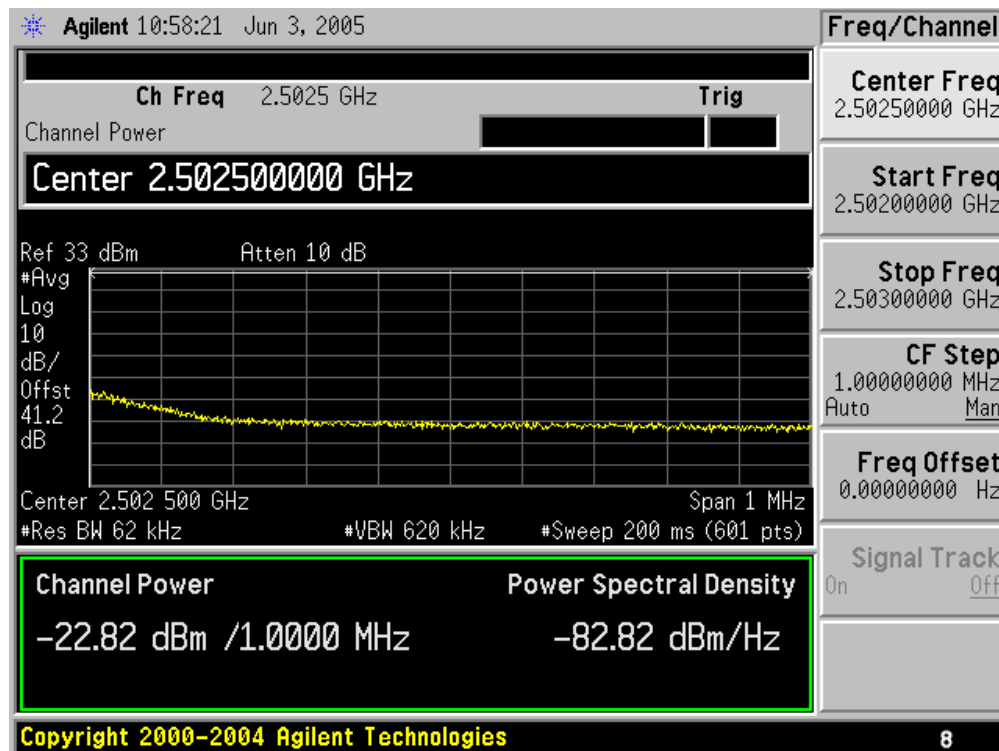
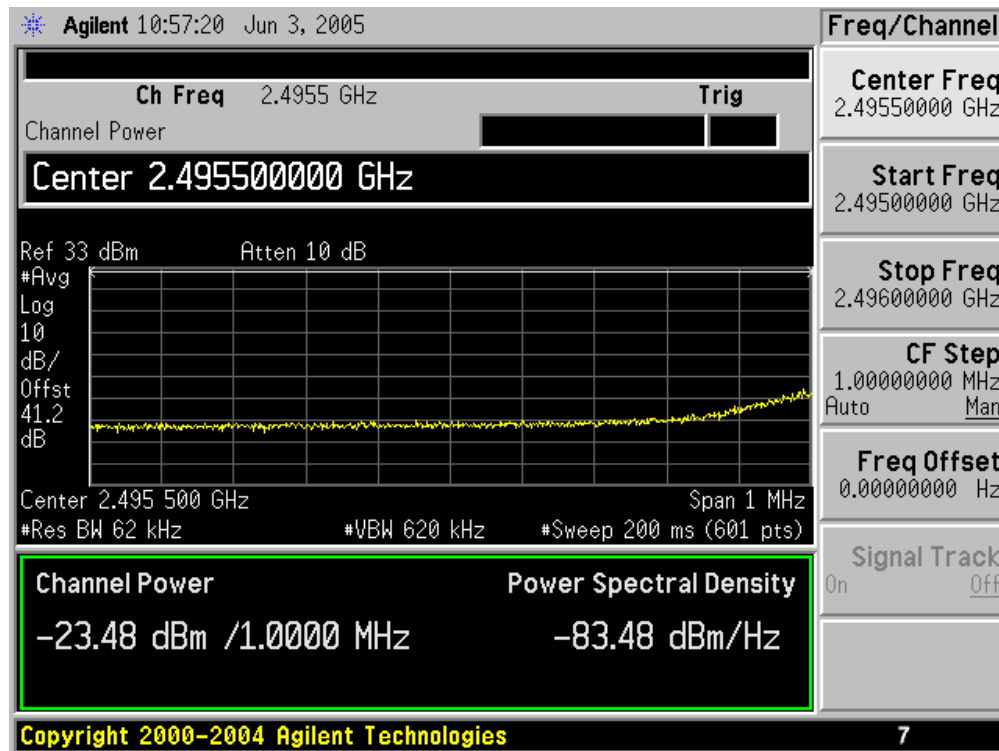

Modulation Characteristics Plots (Cont'd)

Emissions measurements for F=2499 MHz, 6.0 MHz channel, 4-QAM (Cont'd)

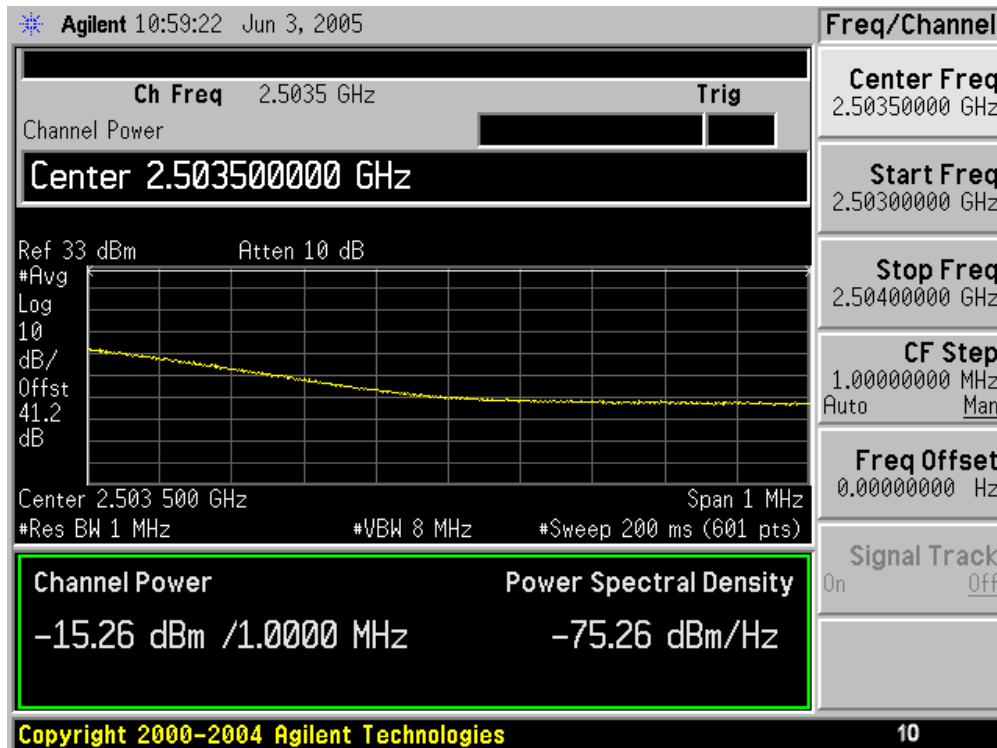
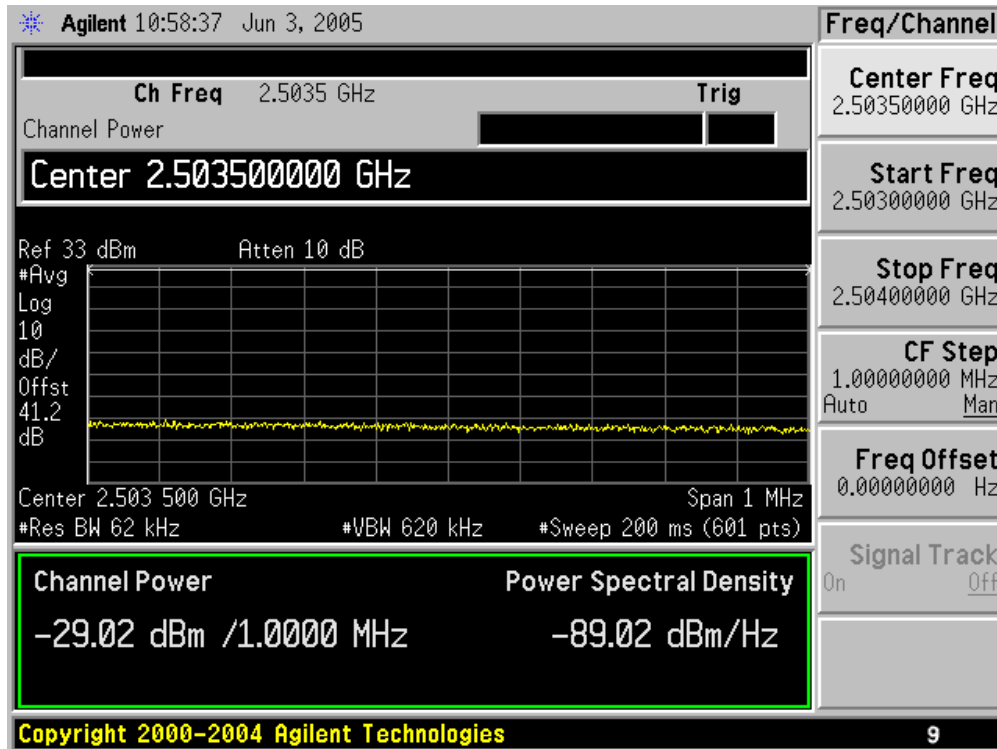

Modulation Characteristics Plots (Cont'd)

Emissions measurements for F=2499 MHz, 6.0 MHz channel, 4-QAM (Cont'd)

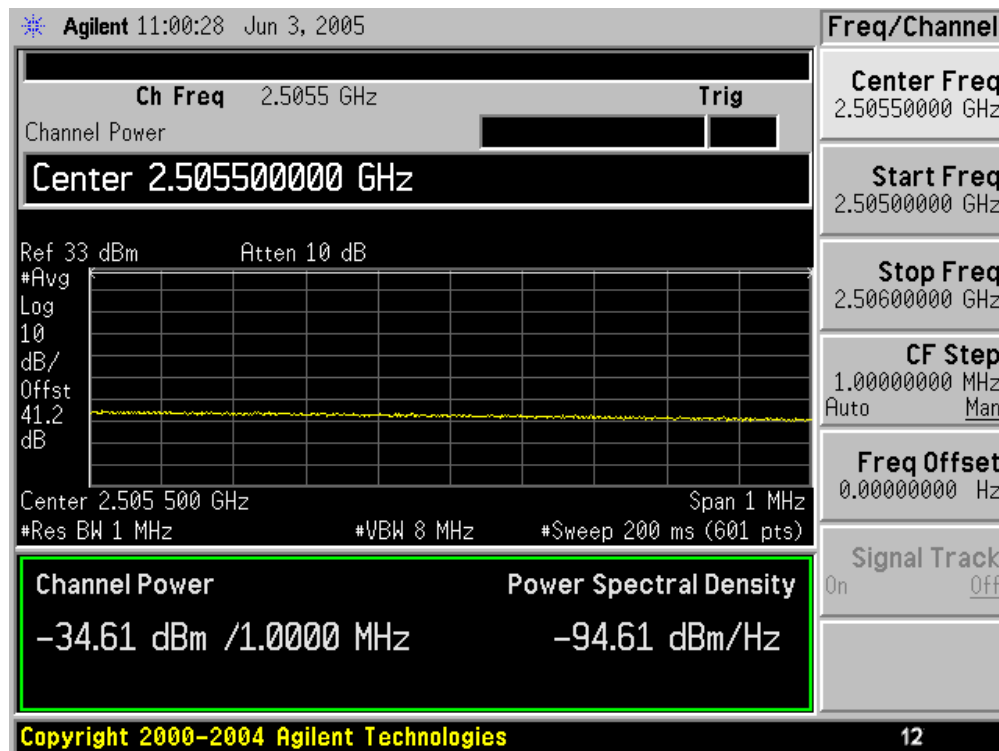
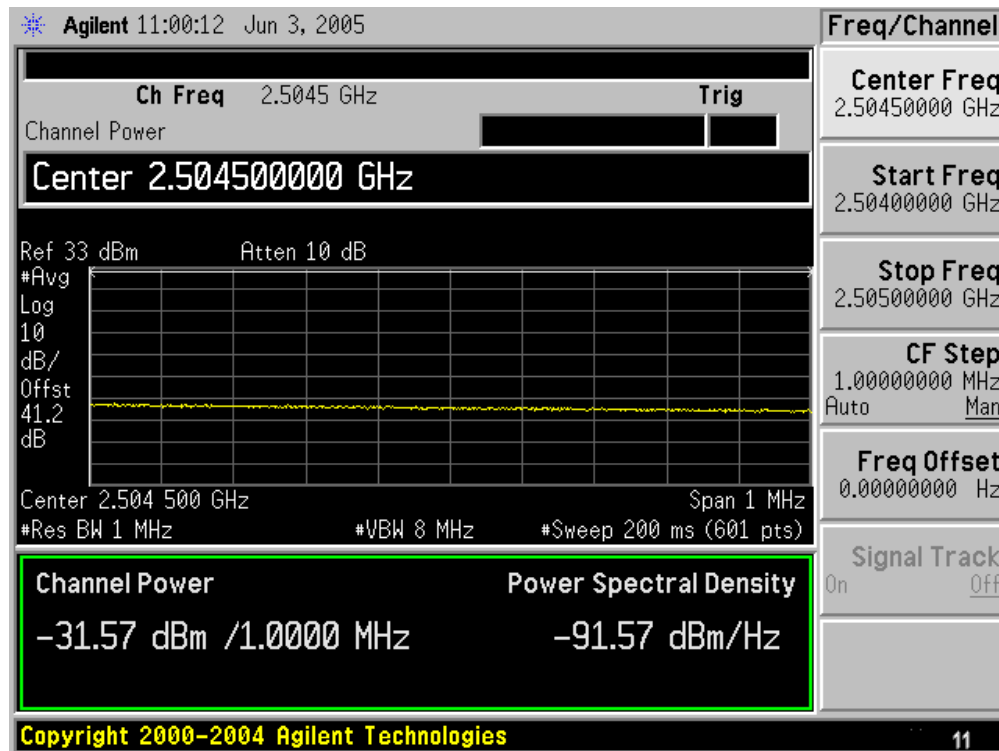

Modulation Characteristics Plots (Cont'd)

Emissions measurements for F=2499 MHz, 6.0 MHz channel, 4-QAM (Cont'd)

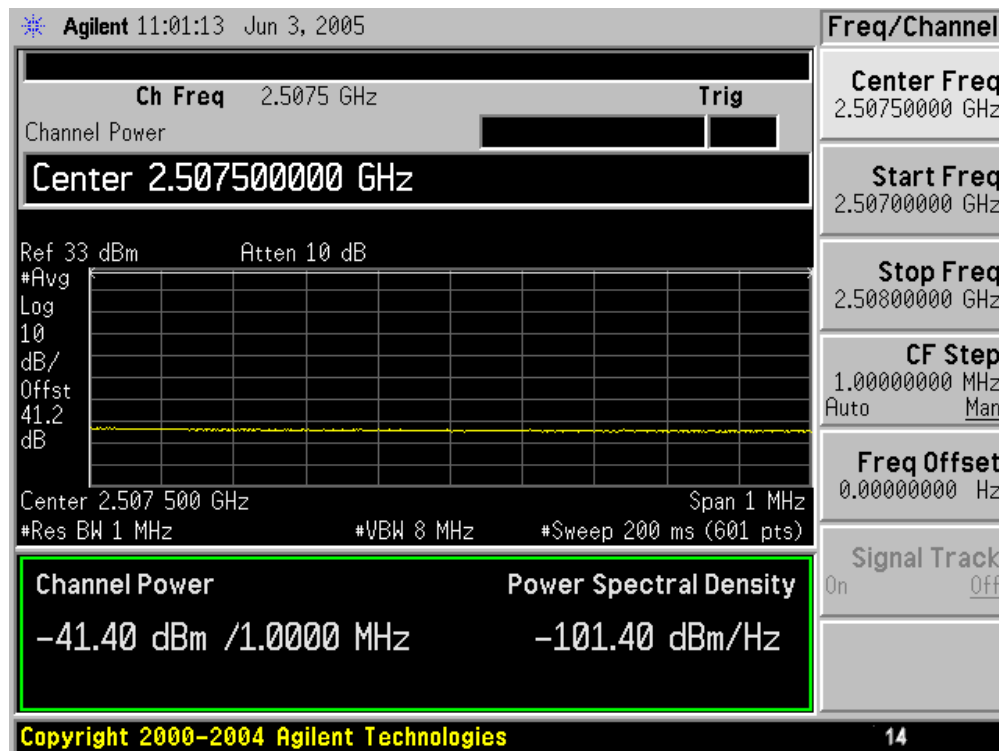
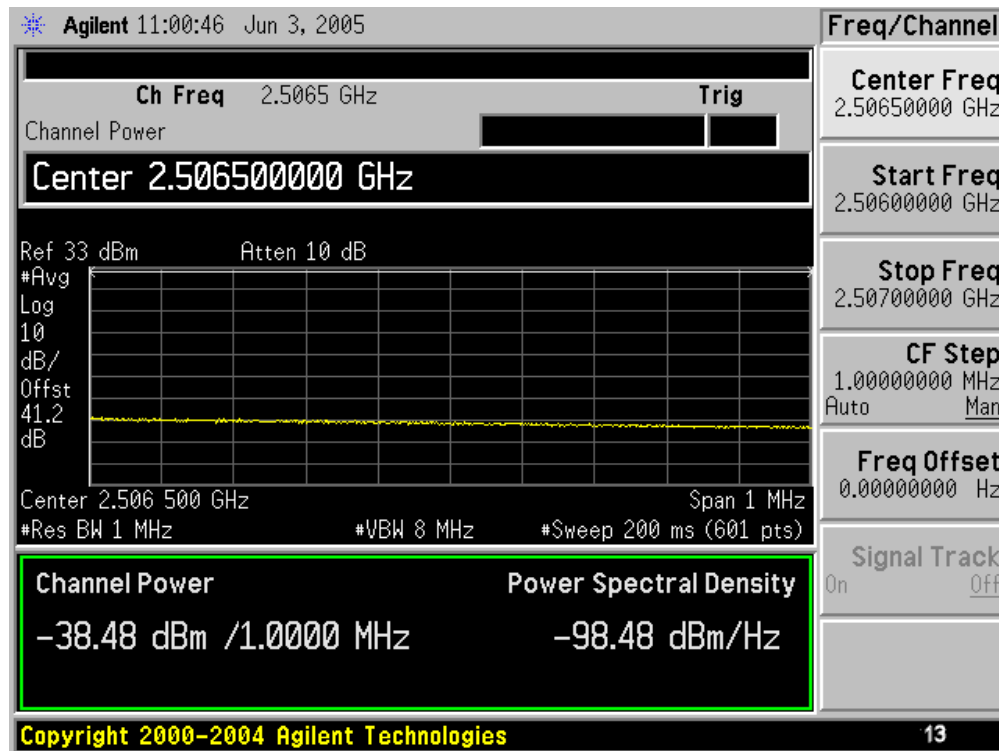

Occupied Bandwidth / Emission Bandwidth

Rule Part Number:

- 2.1049 The occupied bandwidth, that is the frequency bandwidth such that, below its lower and above its upper frequency limits, the mean powers radiated are each equal to 0.5 percent of the total mean power radiated by a given emission shall be measured under the following conditions as applicable:
- 2.1049(h) Each authorization issued pursuant to these rules will show, as the emission designator, a symbol representing the class of emission which shall be prefixed by a number specifying the necessary bandwidth. This figure does not necessarily indicate the bandwidth actually occupied by the emission at any instant. In those cases where part 2 of this chapter does not provide a formula for the computation of the necessary bandwidth, the occupied bandwidth may be used in the emission designator.
- 27.53(l)(6) Measurement procedure. Compliance with these rules is based on the use of measurement instrumentation employing a resolution bandwidth of 1 MHz or greater. However, in the 1 MHz bands immediately outside and adjacent to the frequency block a resolution bandwidth of at least one percent of the emission bandwidth of the fundamental emission of the transmitter may be employed. A narrower resolution bandwidth is permitted in all cases to improve measurement accuracy provided the measured power is integrated over the full required measurement bandwidth (i.e. 1 MHz or 1 percent of emission bandwidth, as specified). The emission bandwidth is defined as the width of the signal between two points, one below the carrier center frequency and one above the carrier center frequency, outside of which all emissions are attenuated at least 26 dB below the transmitter power. With respect to television operations, measurements must be made of the separate visual and aural operating powers at sufficiently frequent intervals to ensure compliance with the rules.

Occupied Bandwidth / Emission Bandwidth

- Standard: ANSI C63.4-2003
American National Standard for Methods of Measurement of Radio- Noise Emissions from Low-Voltage Electrical and Electronic Equipment in the Range of 9 kHz to 40 GHz
- Test Procedure: The Orthogonal Frequency Division Multiplexing (OFDM) modulated Time Division Duplex (TDD) RF transmission from the test unit is applied to a spectrum analyzer. The Spectrum Analyzer is time gated, to capture the transmission during the burst. The bandwidth of the signal is recorded by measuring the modulation bandwidth with the built in measurement function in the spectrum analyzer. The transmitter is enabled in test mode with the attached computer. The RF loss of the attenuators and coax has been measured and is included in the spectrum analyzer offset level. Measurements are performed at frequencies across the band, for each of the modulation formats available (4, 16, and 64-QAM) and channel bandwidths (5.5 MHz and 6 MHz).
- Test Conditions: Frequencies =
5.5 MHz channel: 2504.75, 2565.25, 2626.75, and 2687.25 MHz
6.0 MHz channel: 2499, 2575, and 2621 MHz
Temperature = 25°C
Supply Voltage = 19.5 VDC nominal to RSU

Test Setup:

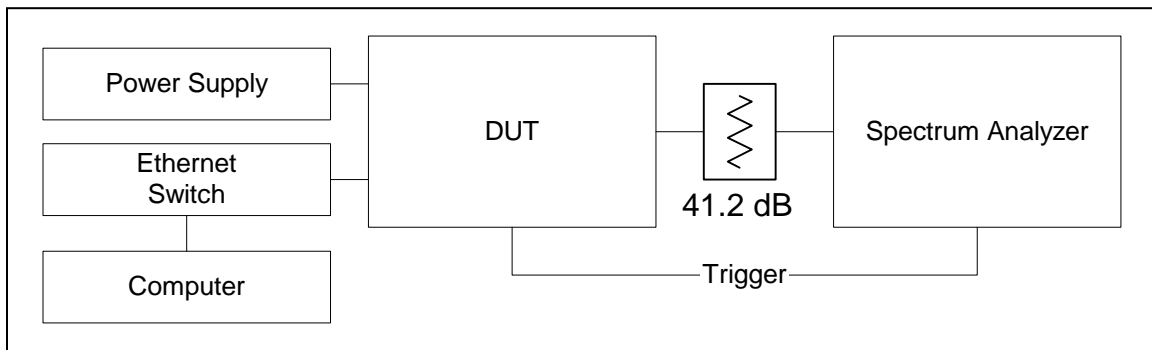

Occupied and Emission Bandwidth Test Setup

Occupied and Emission Bandwidth Test Results Summary

Occupied Bandwidth (MHz) for 20 dB BW (99.0 %)				
Freq (MHz)	4-QAM	16-QAM	64-QAM	Channel BW (MHz)
2504.75	4.958	4.958	4.957	5.5
2565.25	4.959	4.958	4.960	5.5
2626.75	4.957	4.958	4.959	5.5
2687.25	4.959	4.959	4.958	5.5
2499	5.481	5.481	5.482	6.0
2575	5.482	5.483	5.482	6.0
2621	5.481	5.481	5.482	6.0

Emission Bandwidth (MHz) for 26 dB BW (99.75 %)				
Freq (MHz)	4-QAM	16-QAM	64-QAM	Channel BW (MHz)
2504.75	5.021	5.021	5.020	5.5
2565.25	5.022	5.020	5.019	5.5
2626.75	5.023	5.021	5.021	5.5
2687.25	5.019	5.020	5.020	5.5
2499	5.548	5.547	5.548	6.0
2575	5.550	5.549	5.548	6.0
2621	5.547	5.548	5.548	6.0

Test Results:

Pass Occupied and Emission Bandwidth tests.

Occupied Bandwidth Spectrum Analyzer Plots 5.5 MHz Channels/4-QAM

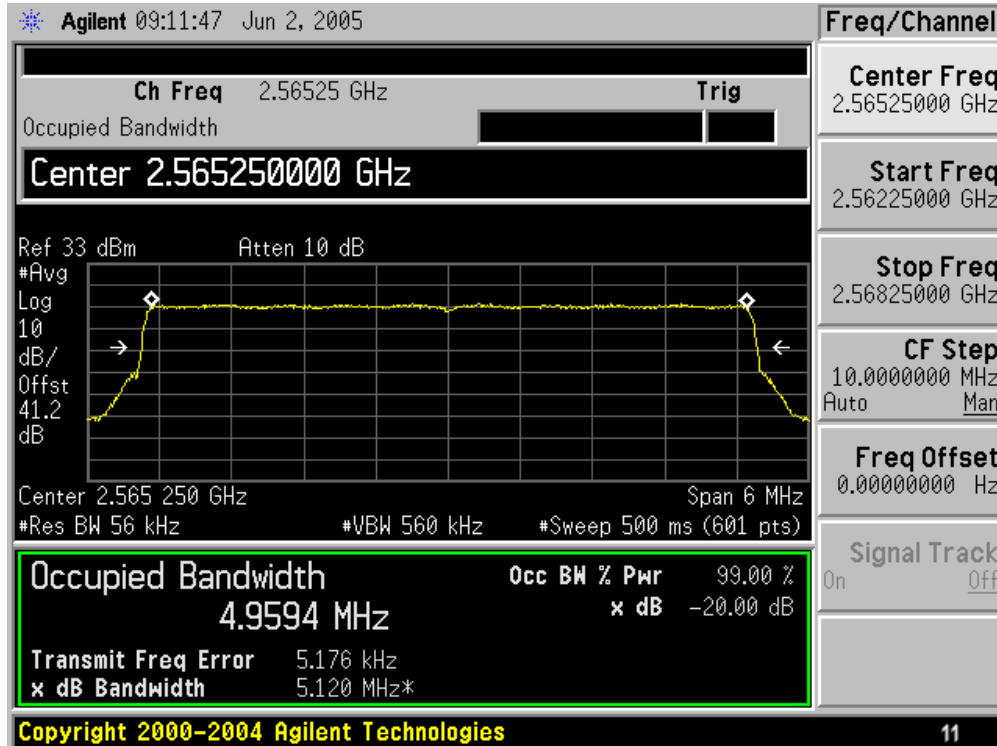
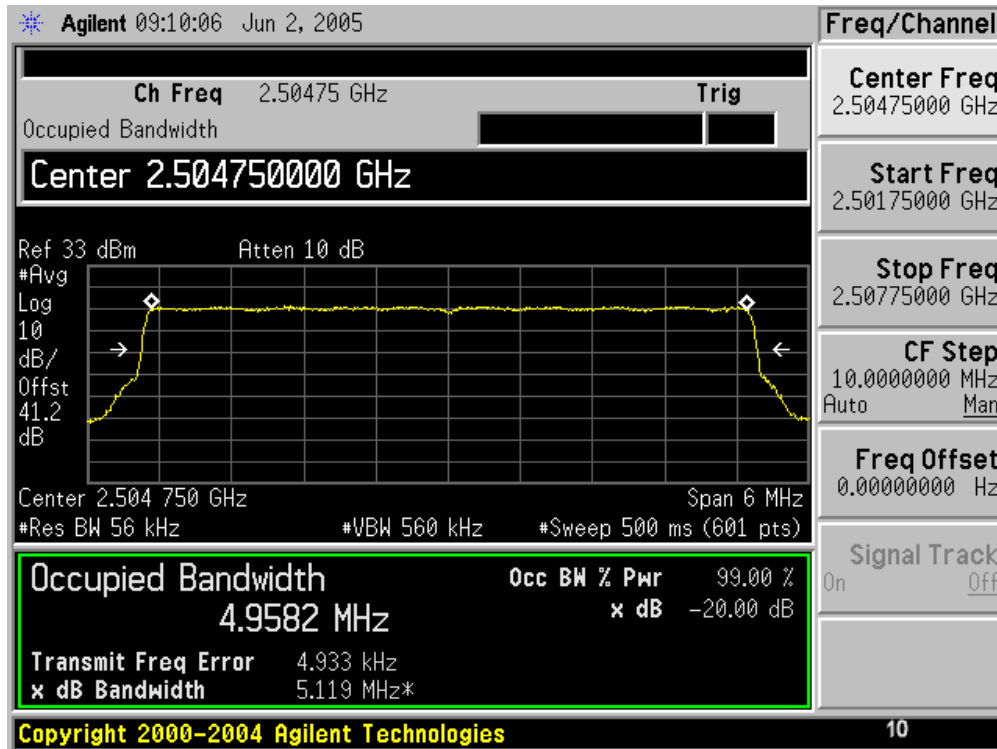

Occupied Bandwidth 5.5 MHz Channels/4-QAM (Cont'd)

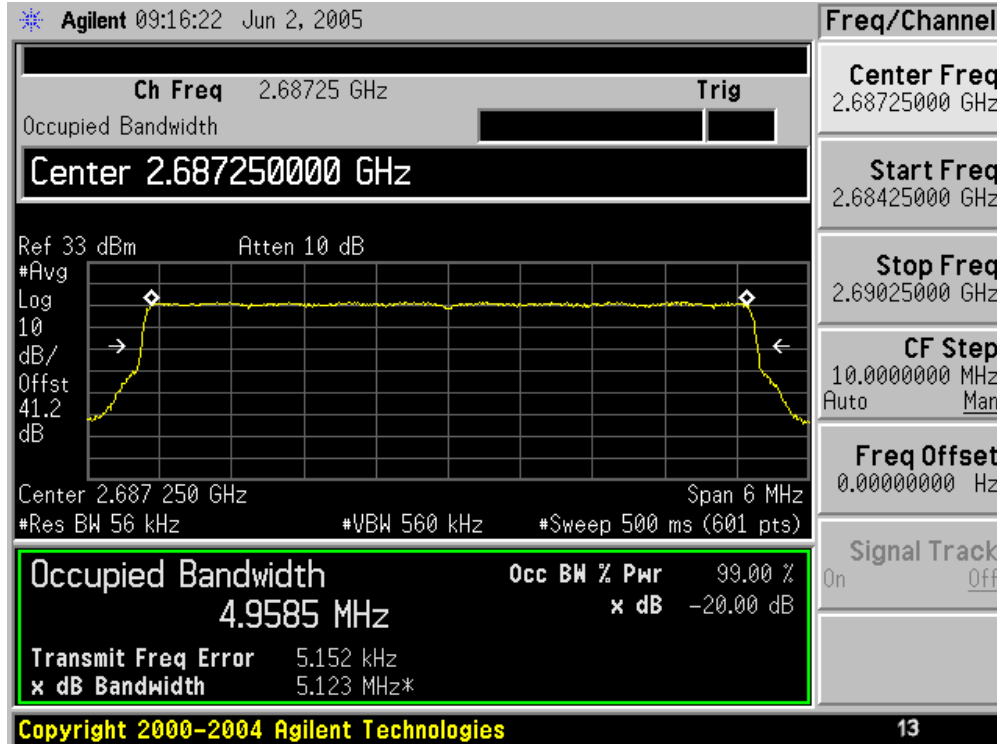
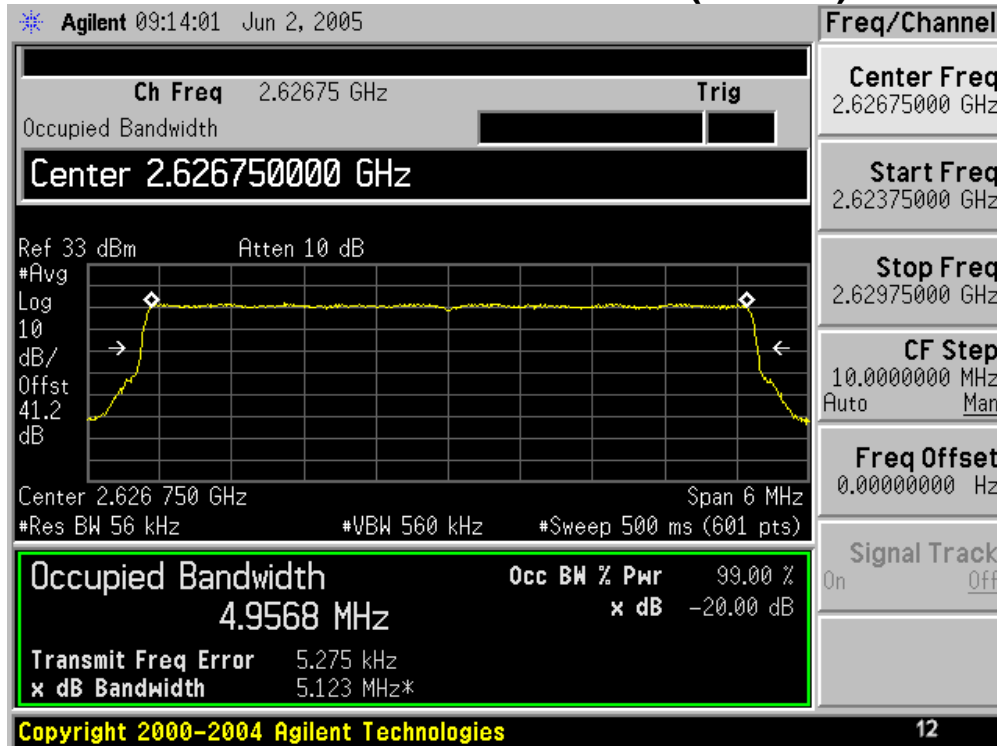

Occupied Bandwidth 5.5 MHz Channels/16-QAM (Cont'd)

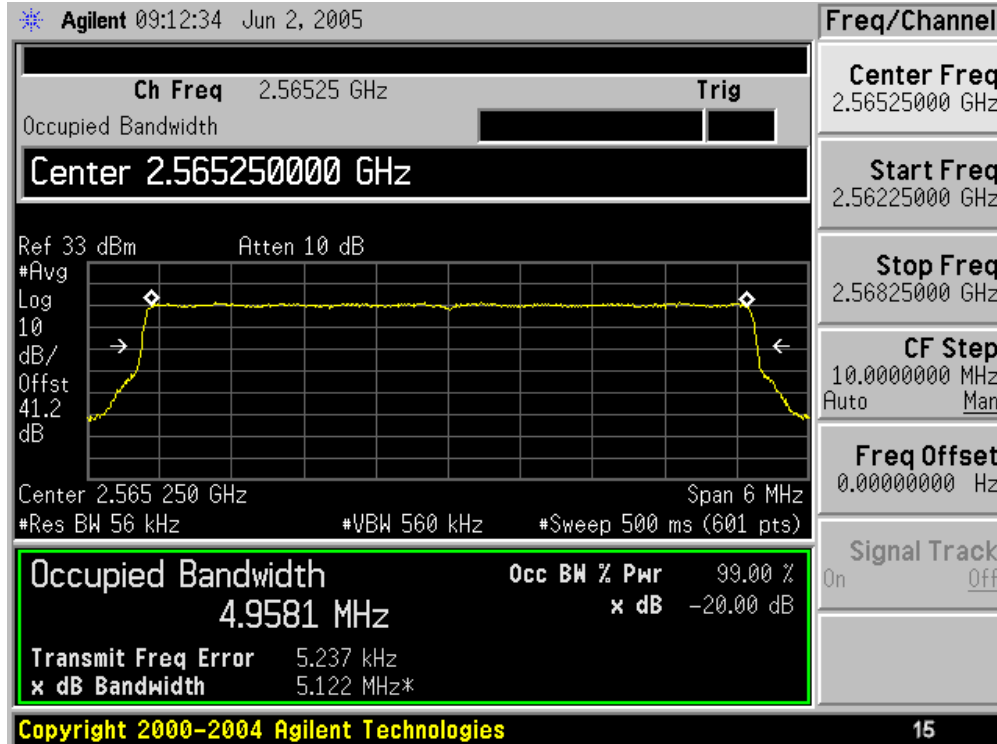
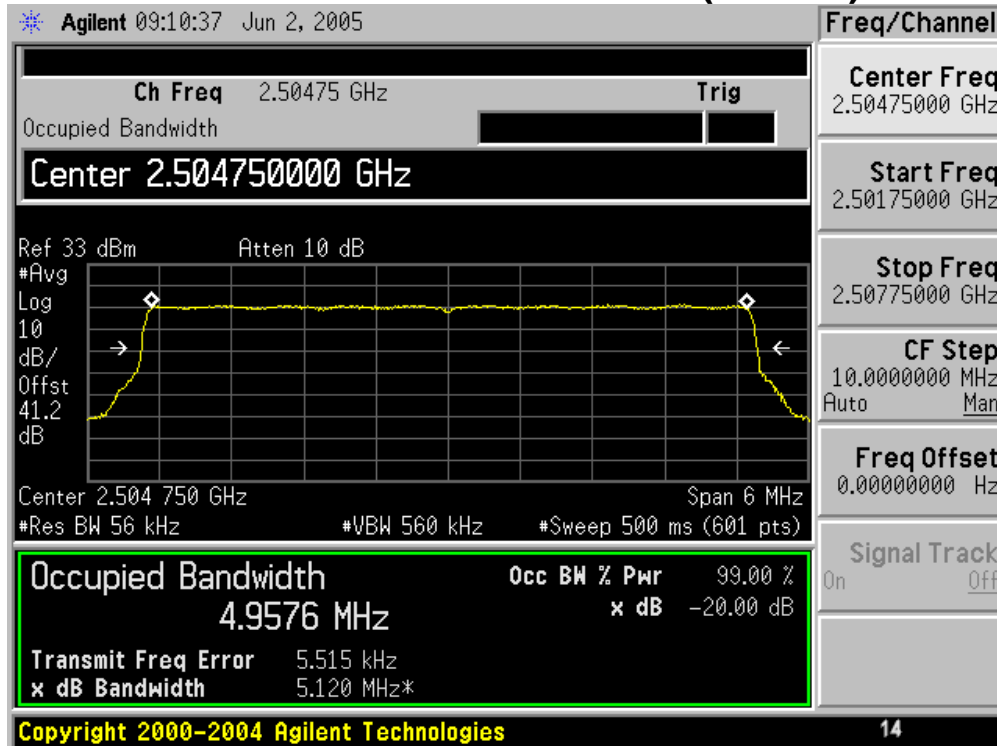

Occupied Bandwidth 5.5 MHz Channels/16-QAM (Cont'd)

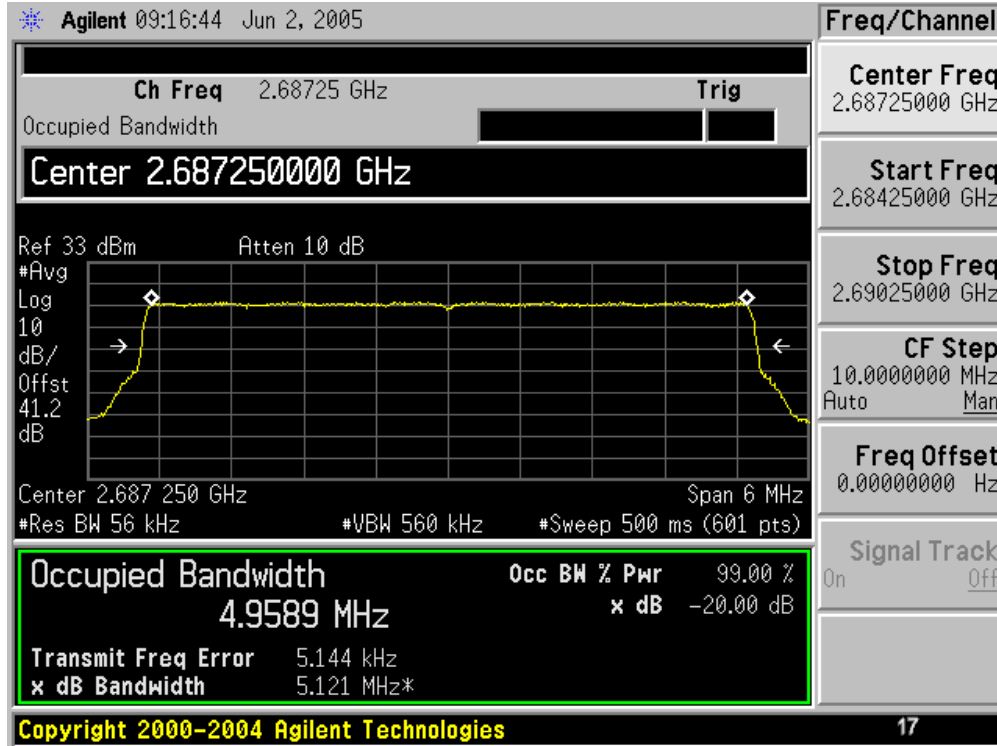
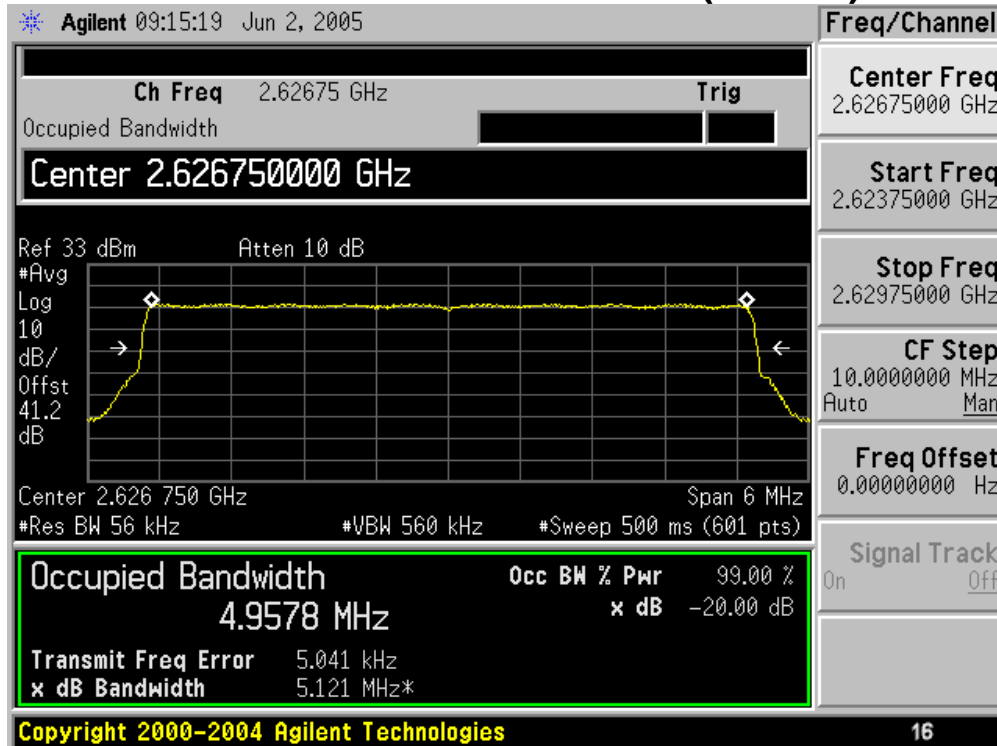

Occupied Bandwidth 5.5 MHz Channels/64-QAM

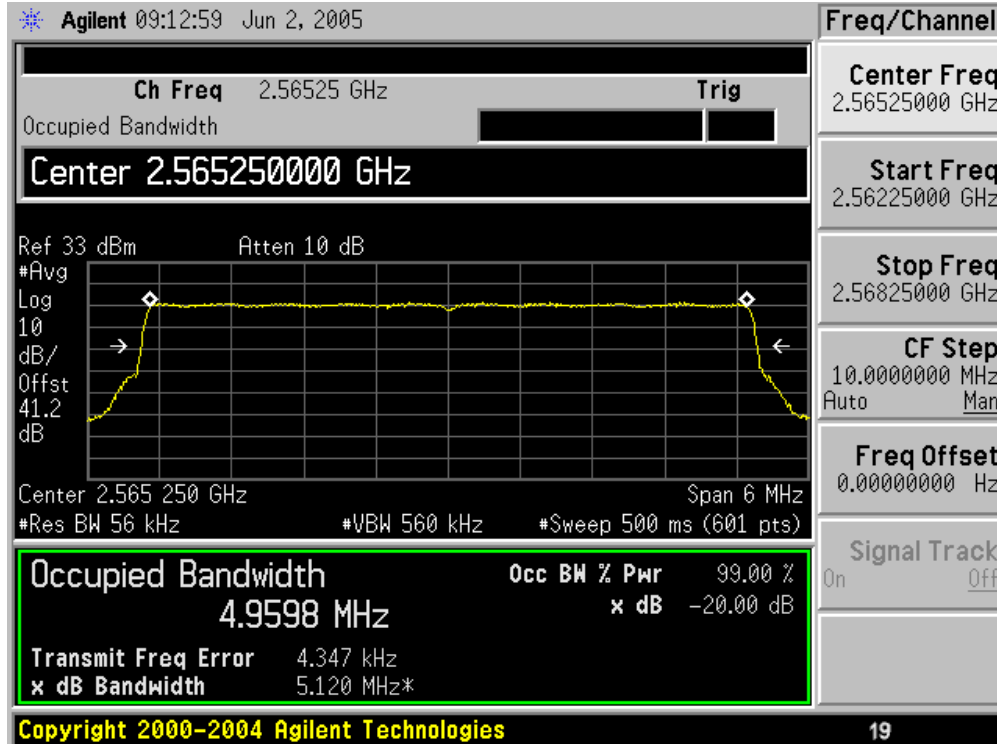
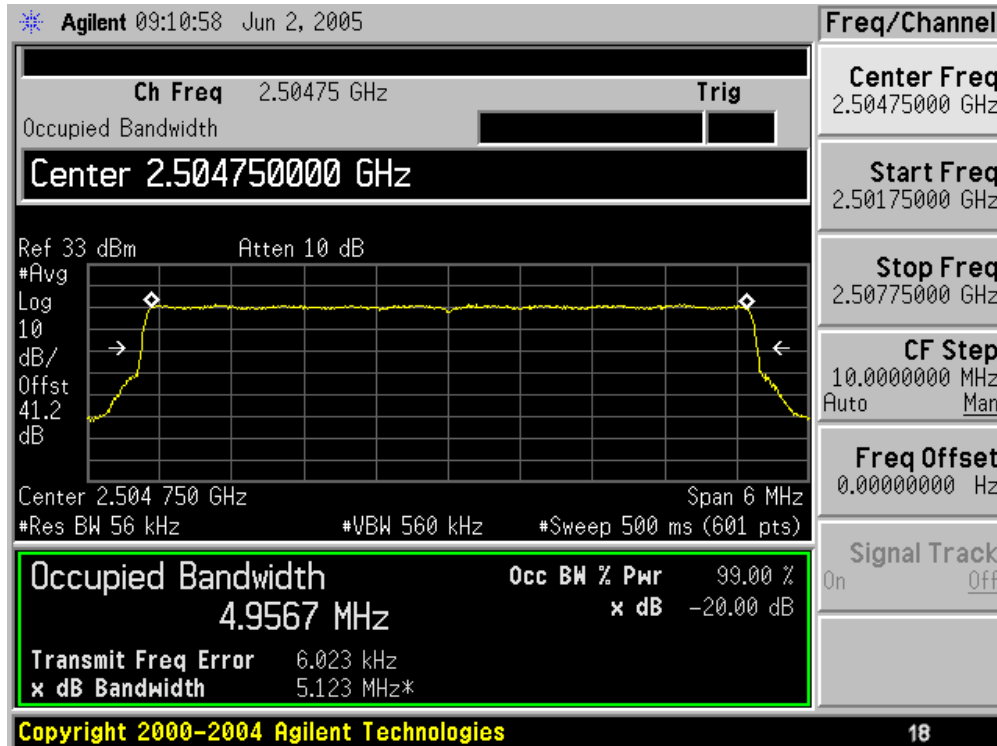

Occupied Bandwidth 5.5 MHz Channels/64-QAM (Cont'd)

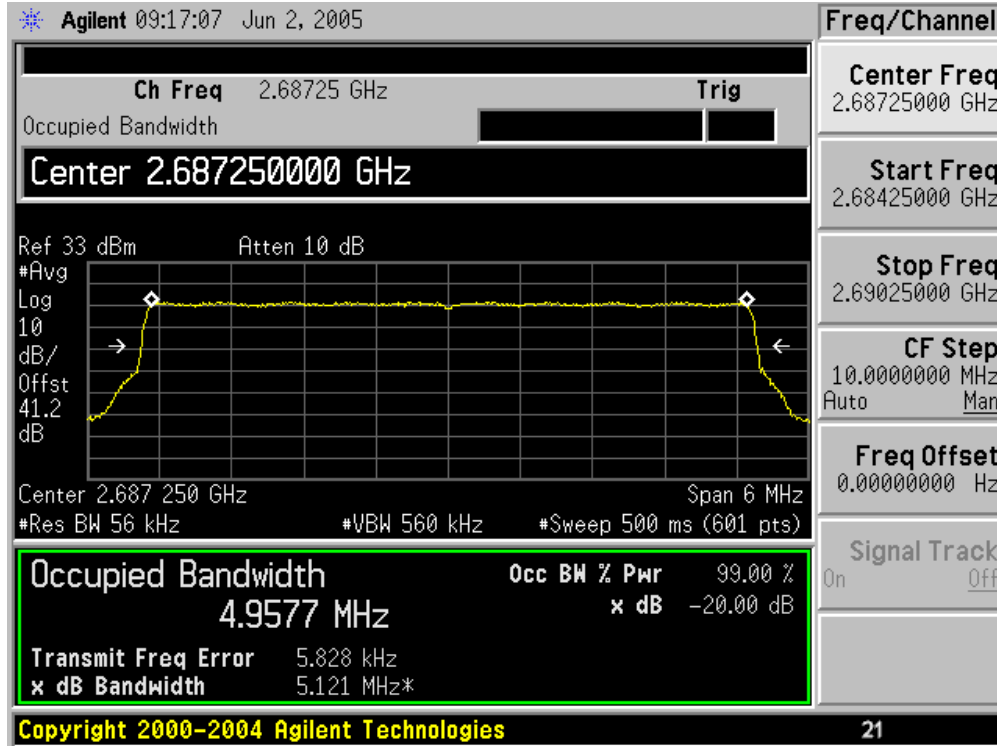
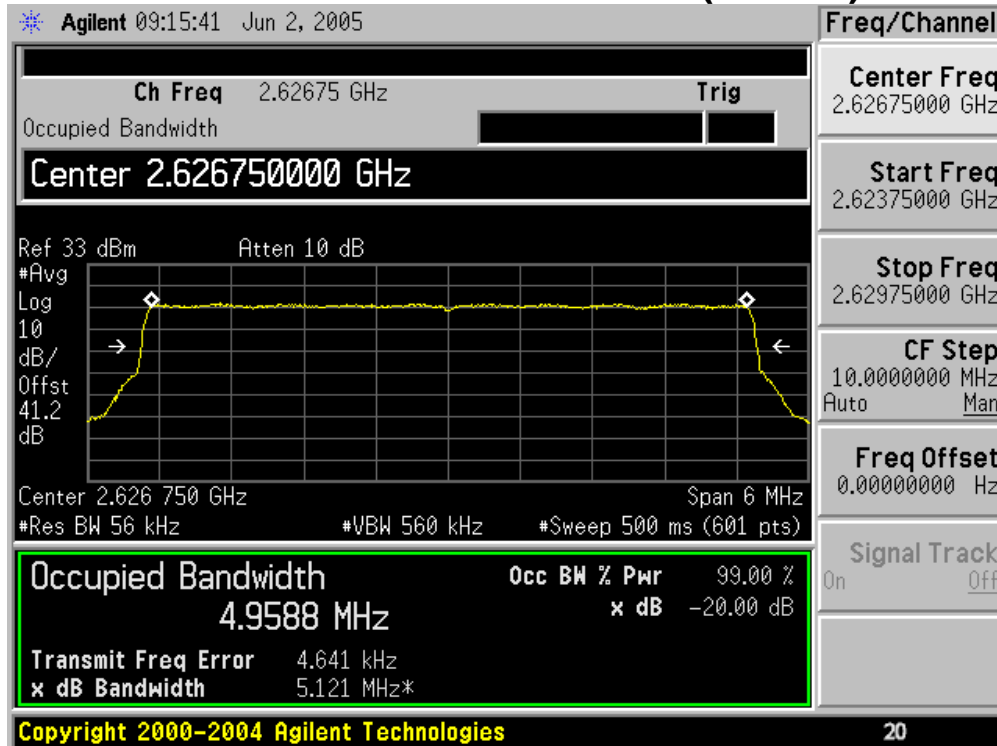

Occupied Bandwidth 6.0 MHz Channels/4-QAM

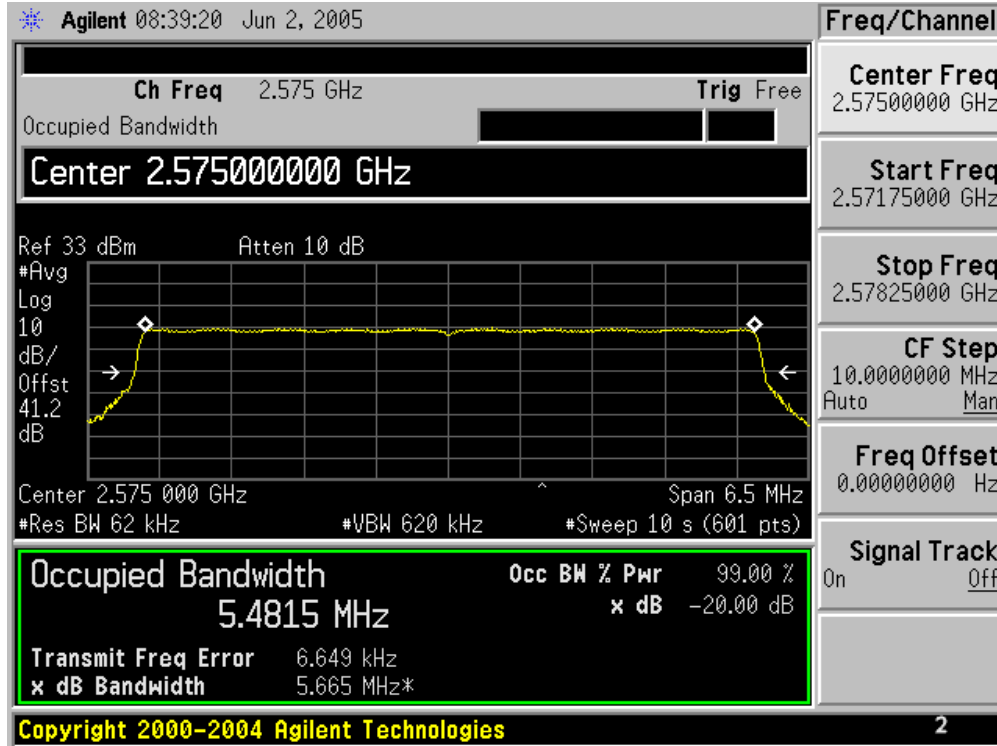
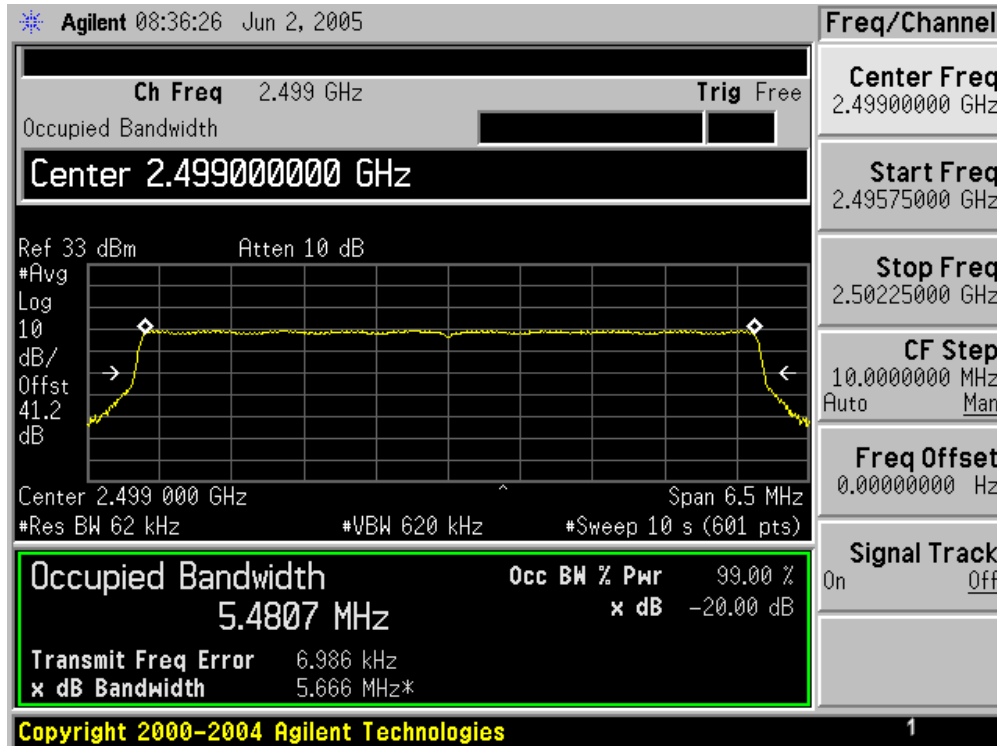

Occupied Bandwidth 6.0 MHz Channels/4-QAM (Cont'd)

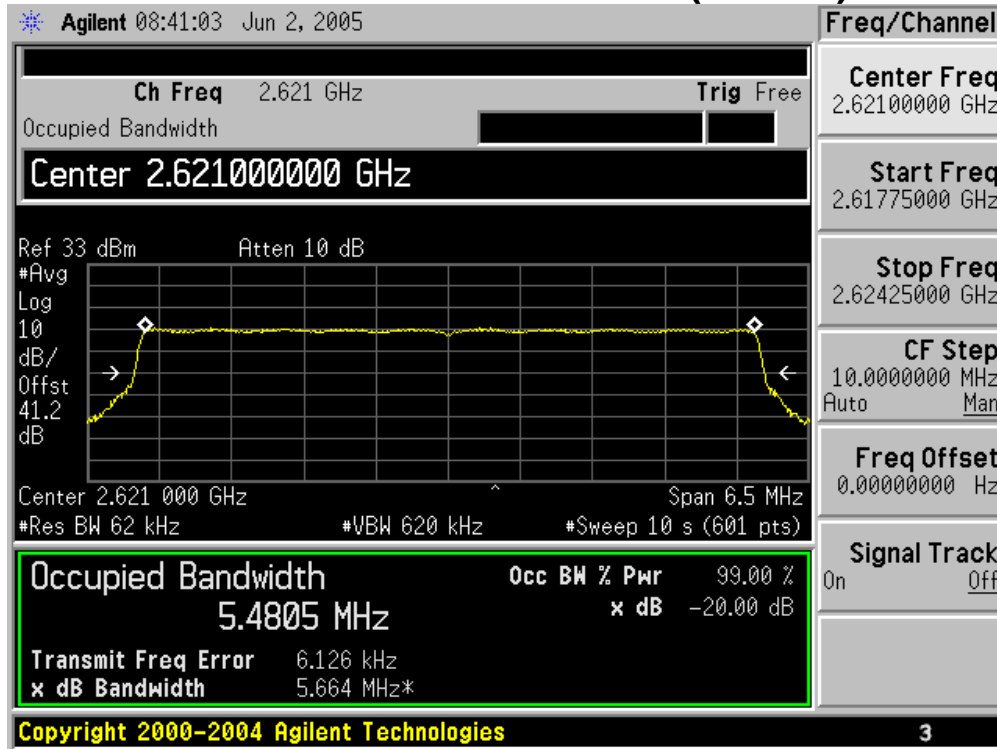

Occupied Bandwidth 6.0 MHz Channels/16-QAM

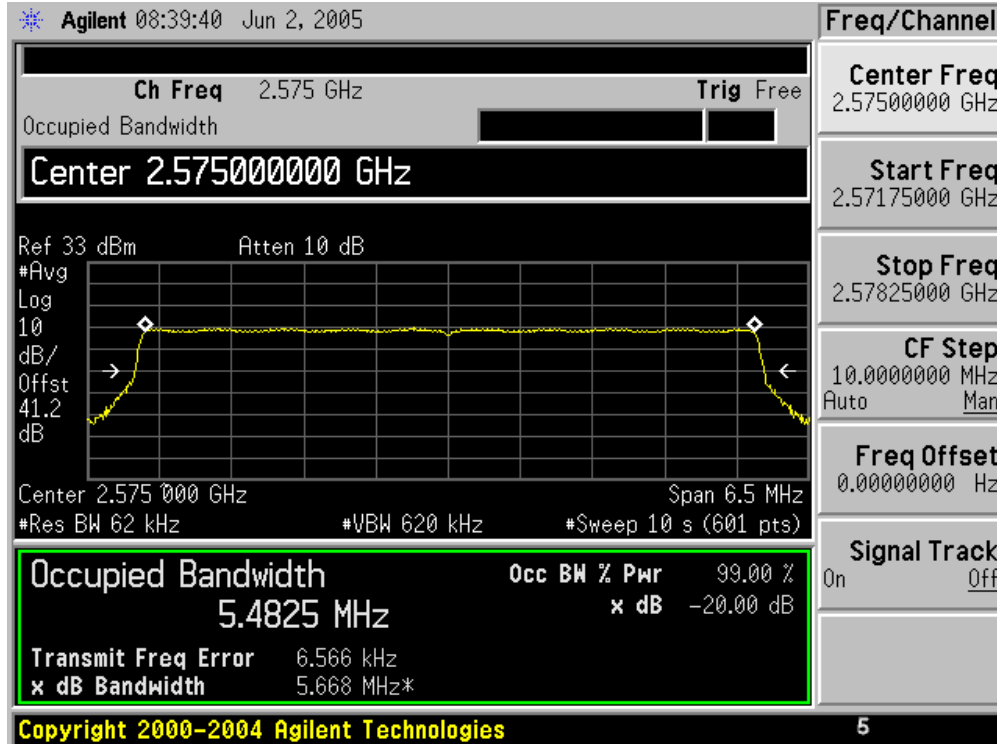
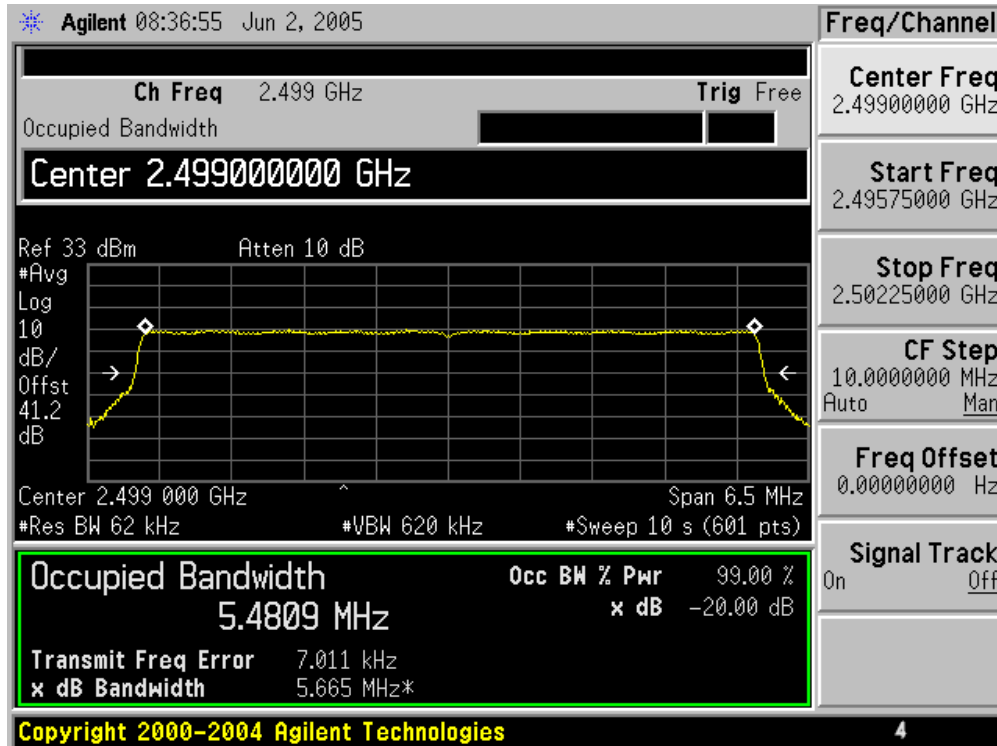

Occupied Bandwidth 6.0 MHz Channels/16-QAM (Cont'd)

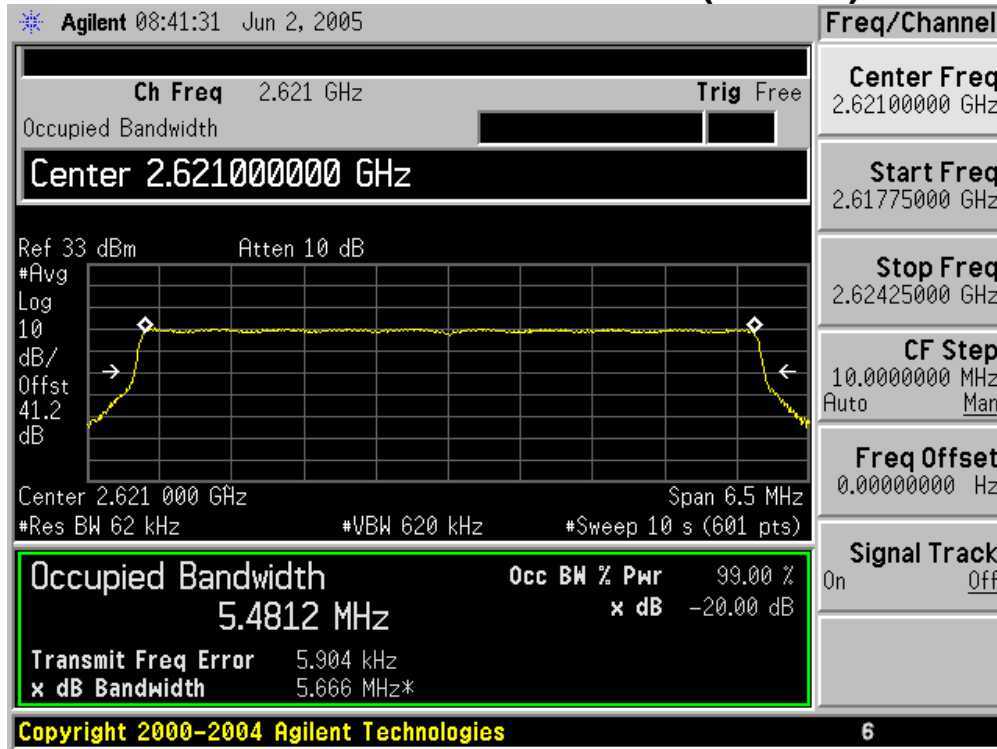

Occupied Bandwidth 6.0 MHz Channels/64-QAM

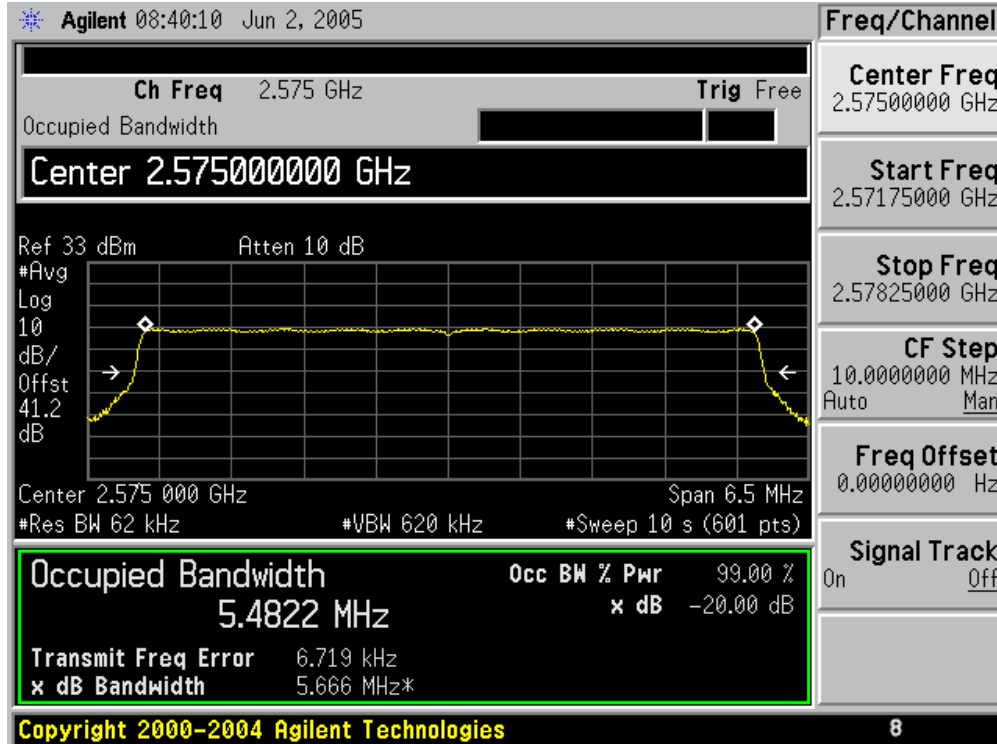
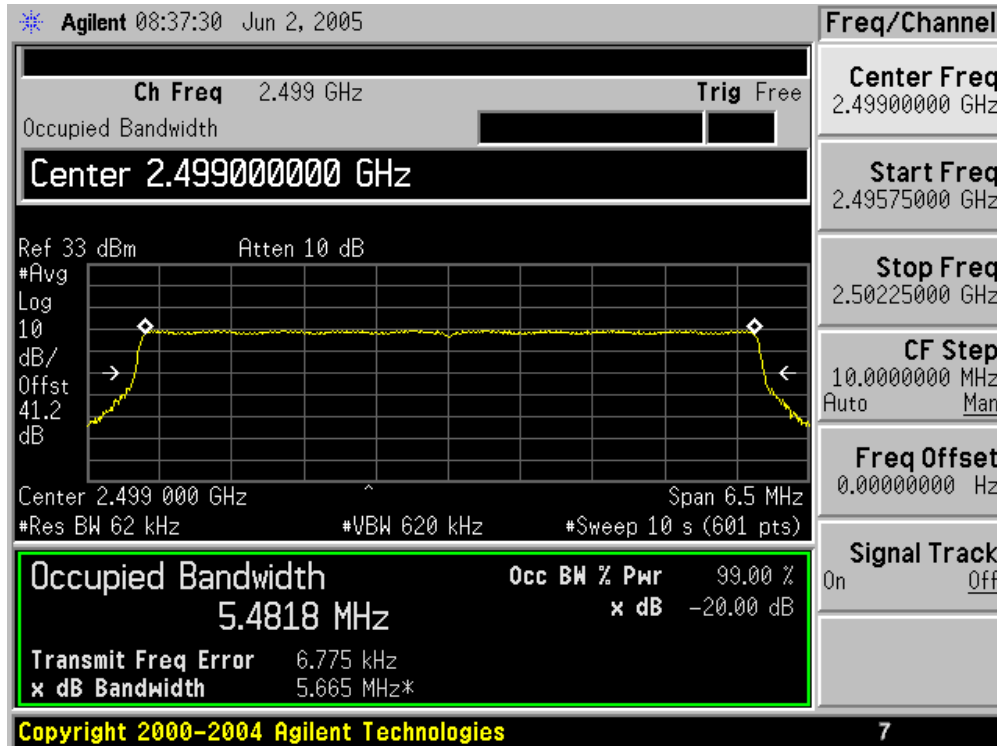

Occupied Bandwidth 6.0 MHz Channels/64-QAM (Cont'd)

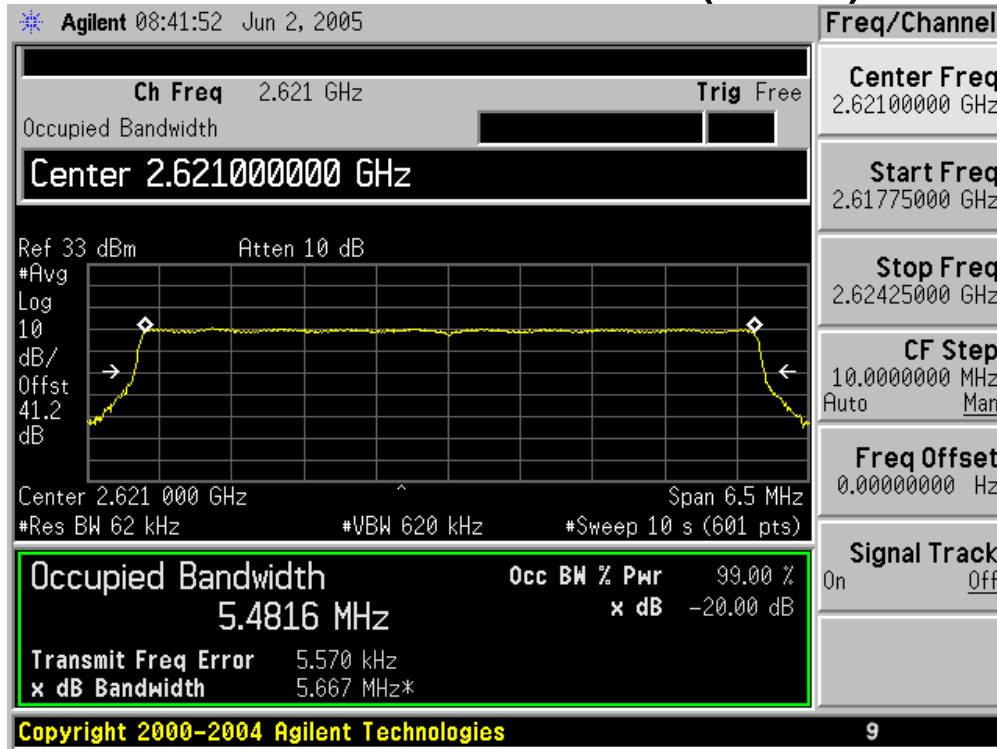

Emission Bandwidth Spectrum Analyzer Plots 5.5 MHz Channels/4-QAM

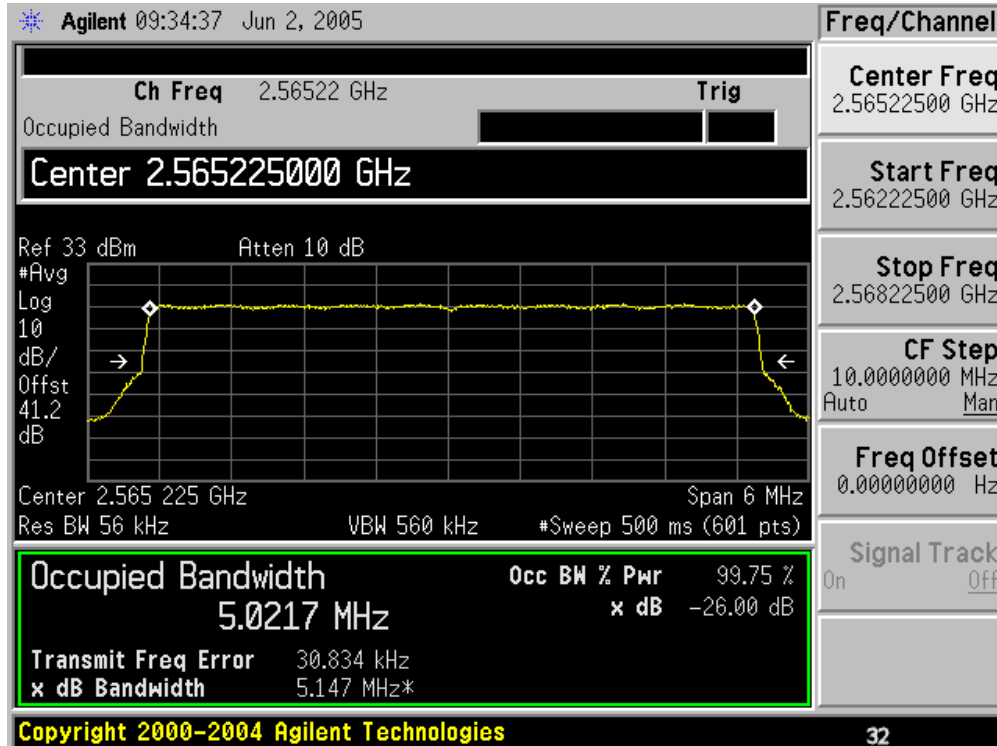
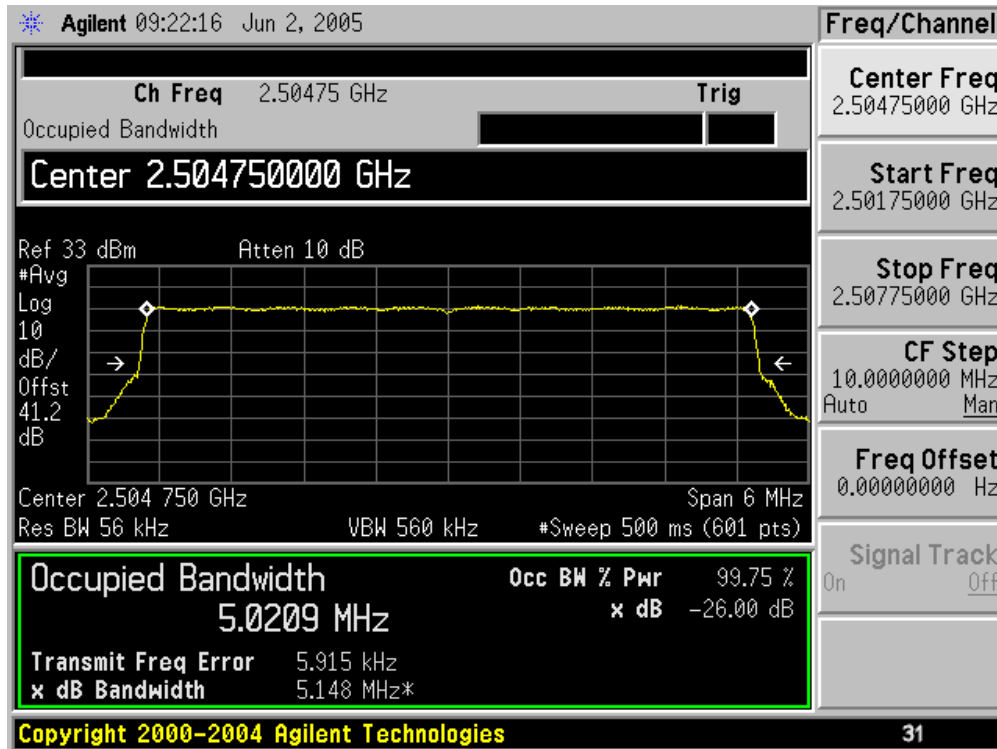

Emission Bandwidth 5.5 MHz Channels/4-QAM (Cont'd)

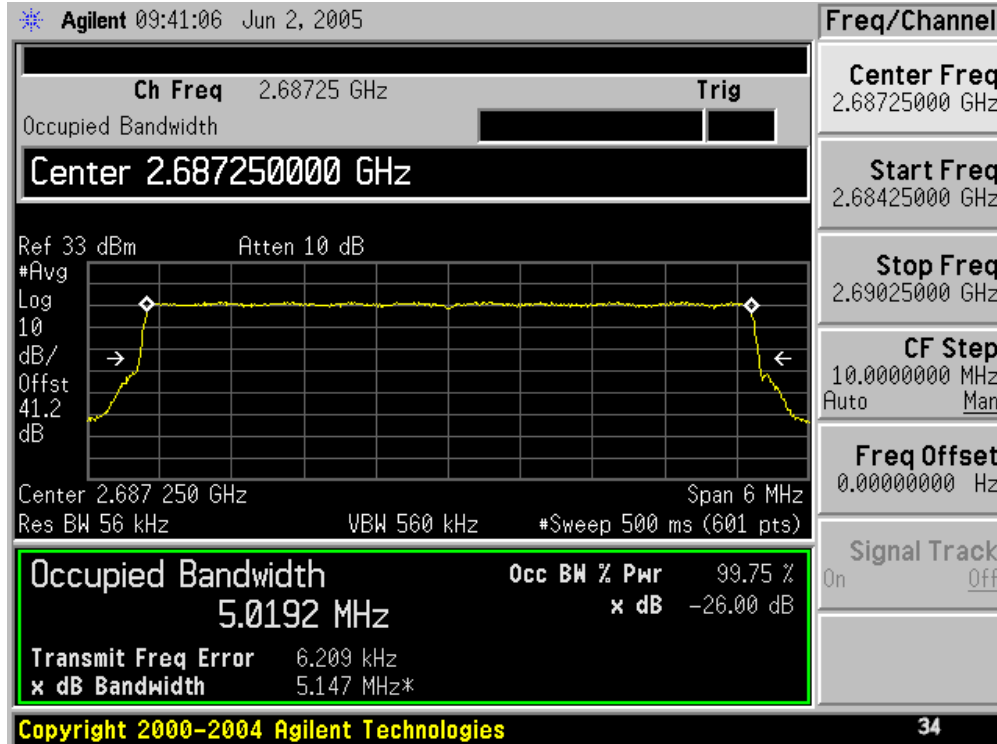
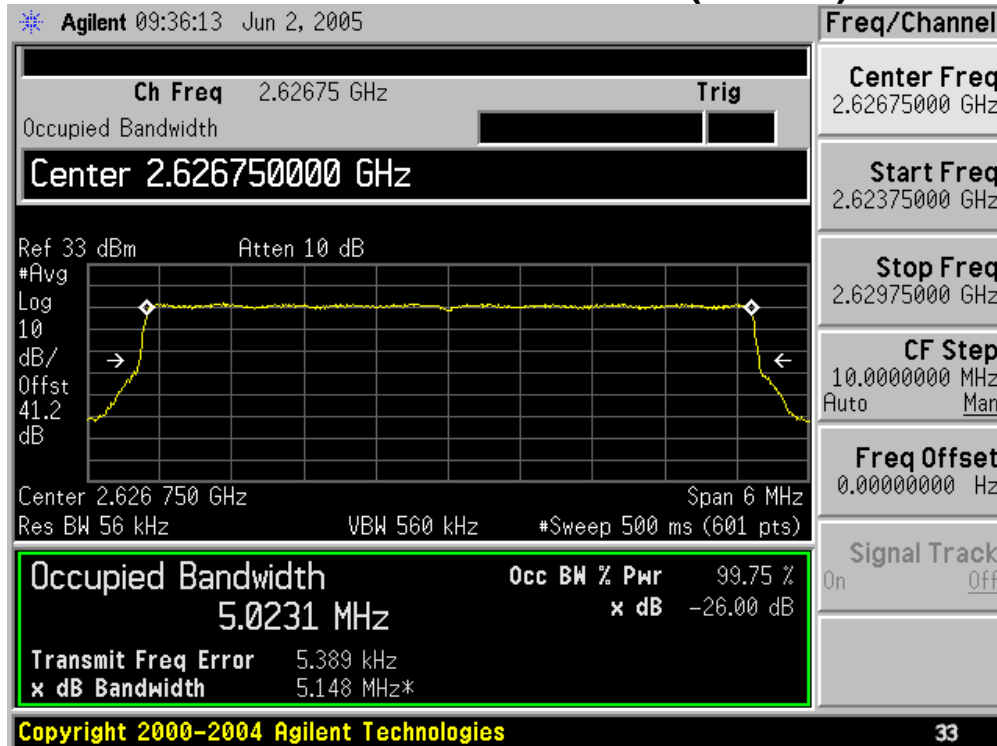

Emission Bandwidth 5.5 MHz Channels/16-QAM

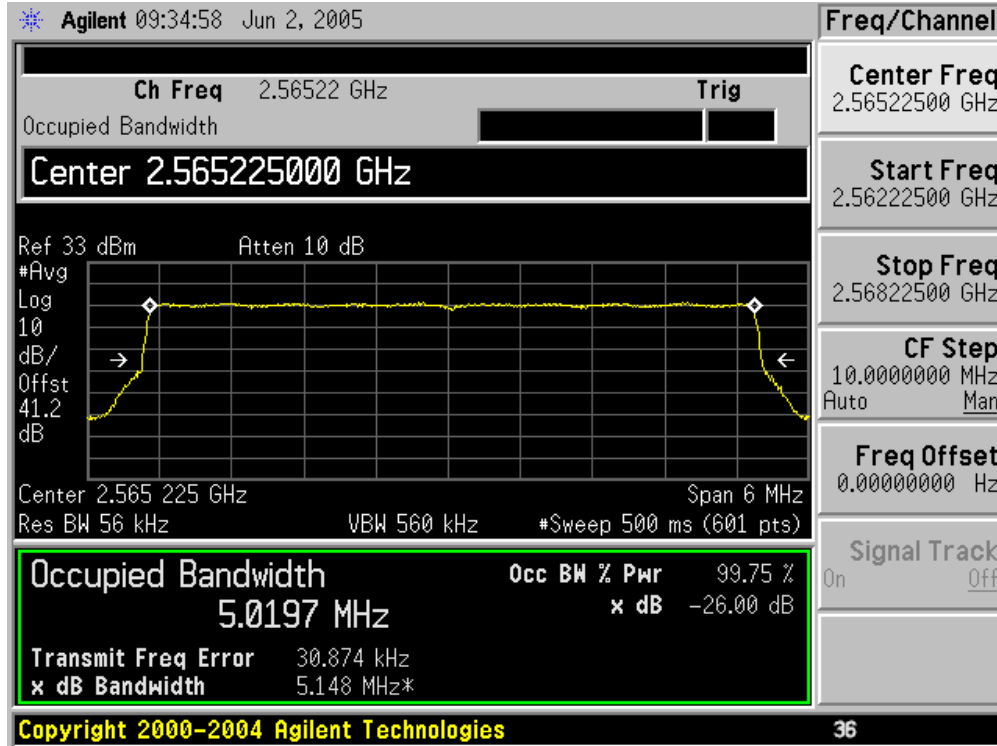
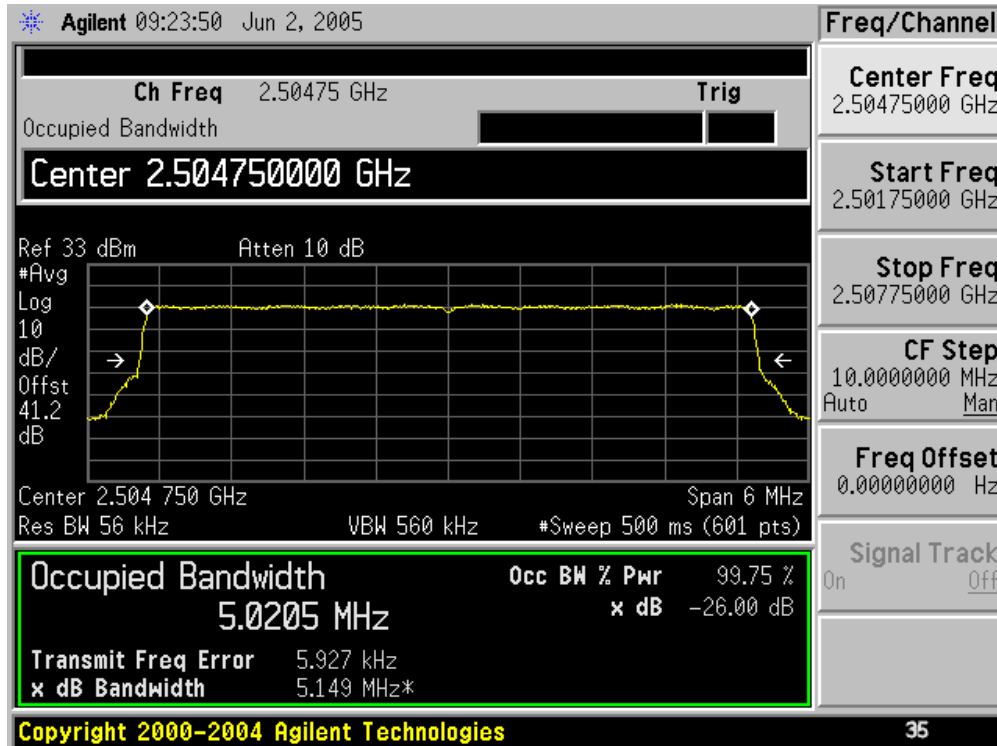

Emission Bandwidth 5.5 MHz Channels/16-QAM (Cont'd)

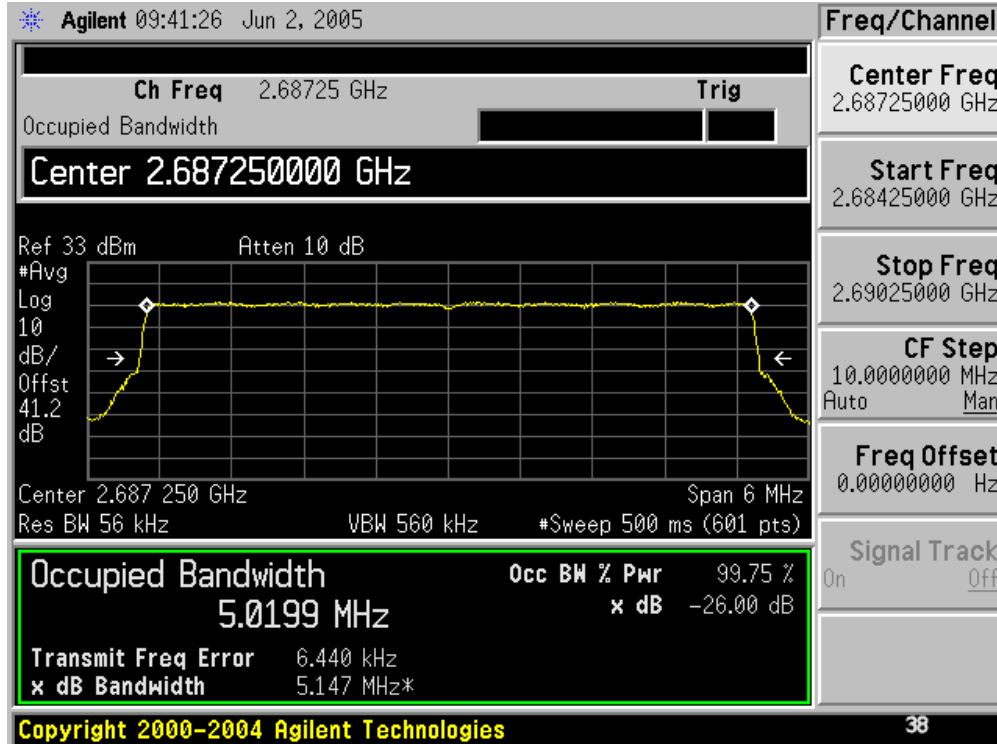
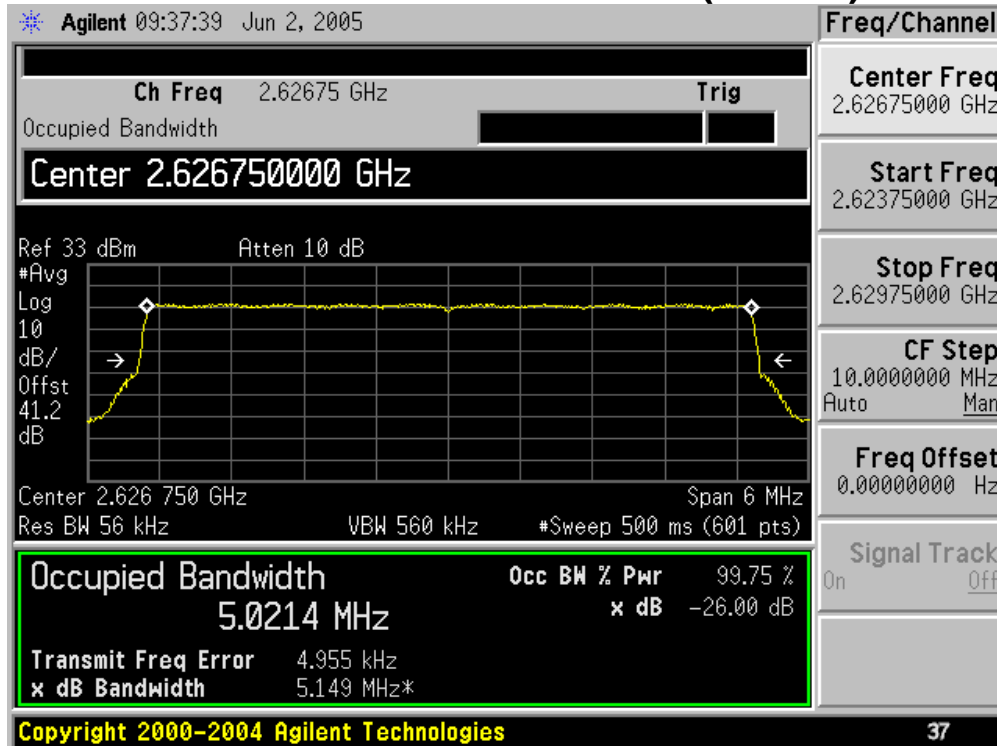

Emission Bandwidth 5.5 MHz Channels/64-QAM

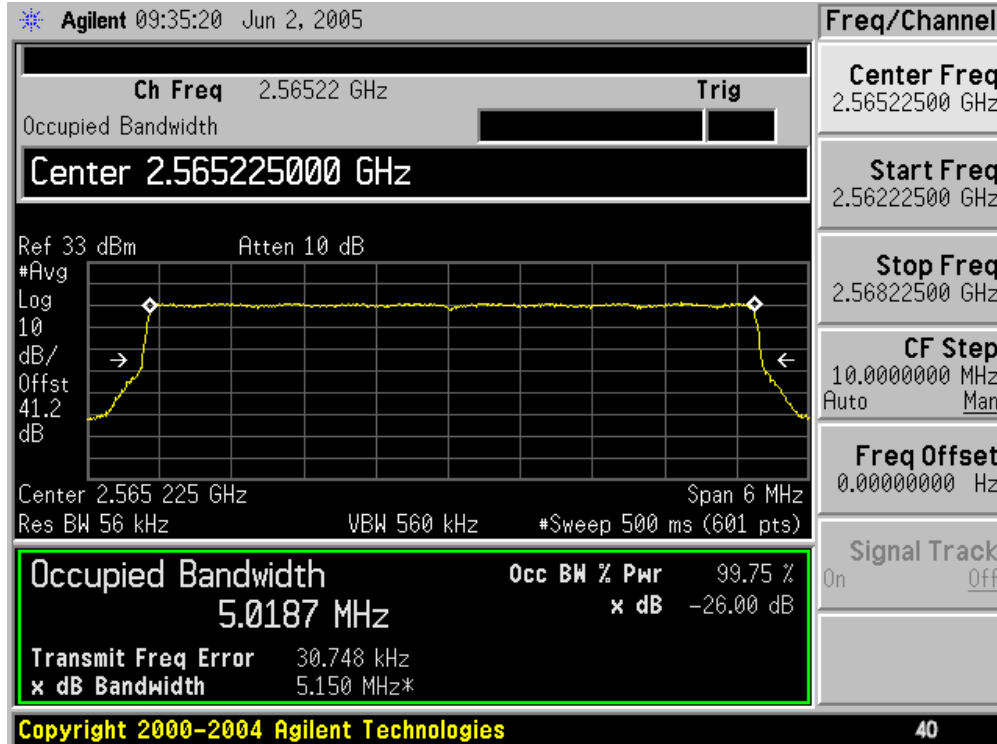
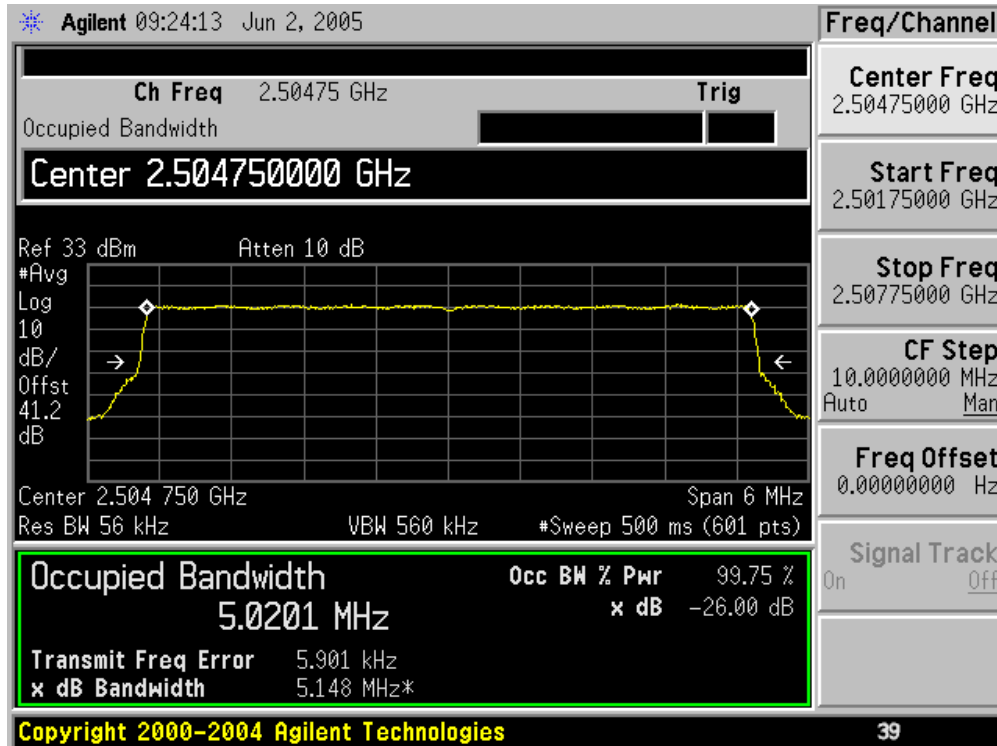

Emission Bandwidth 5.5 MHz Channels/64-QAM (Cont'd)

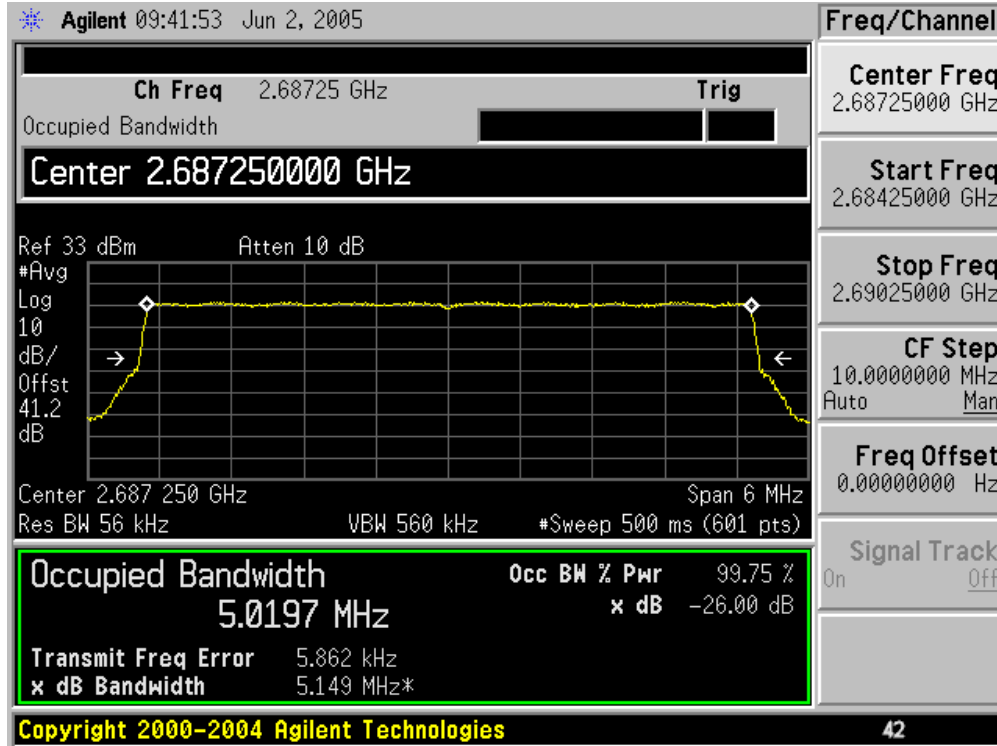
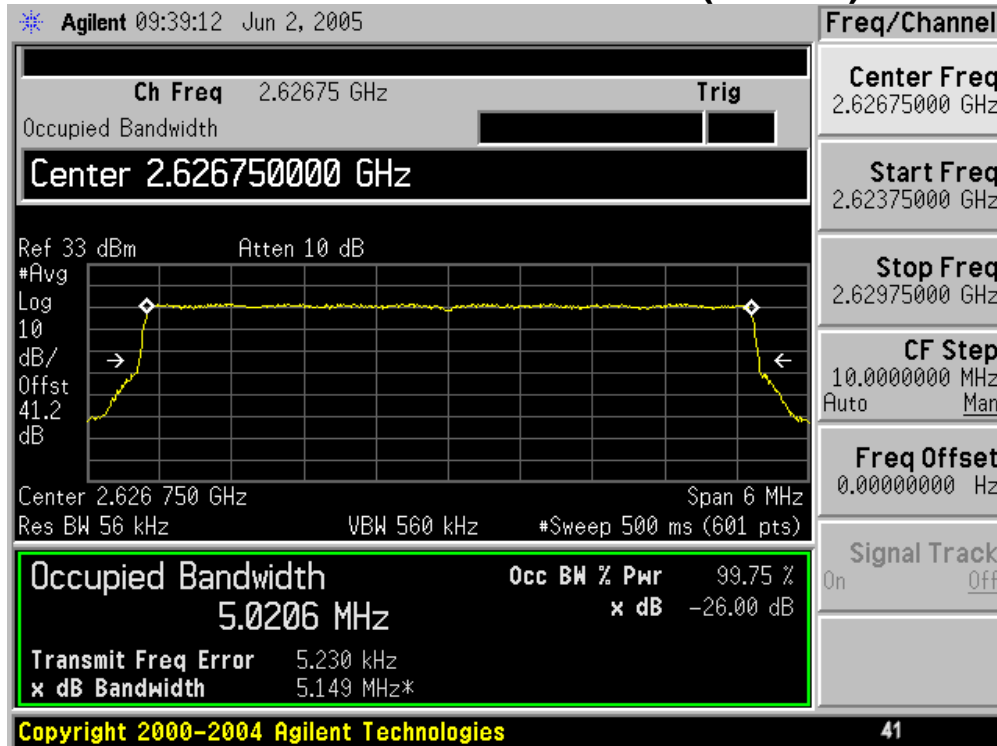

Emission Bandwidth 6.0 MHz Channels/4-QAM

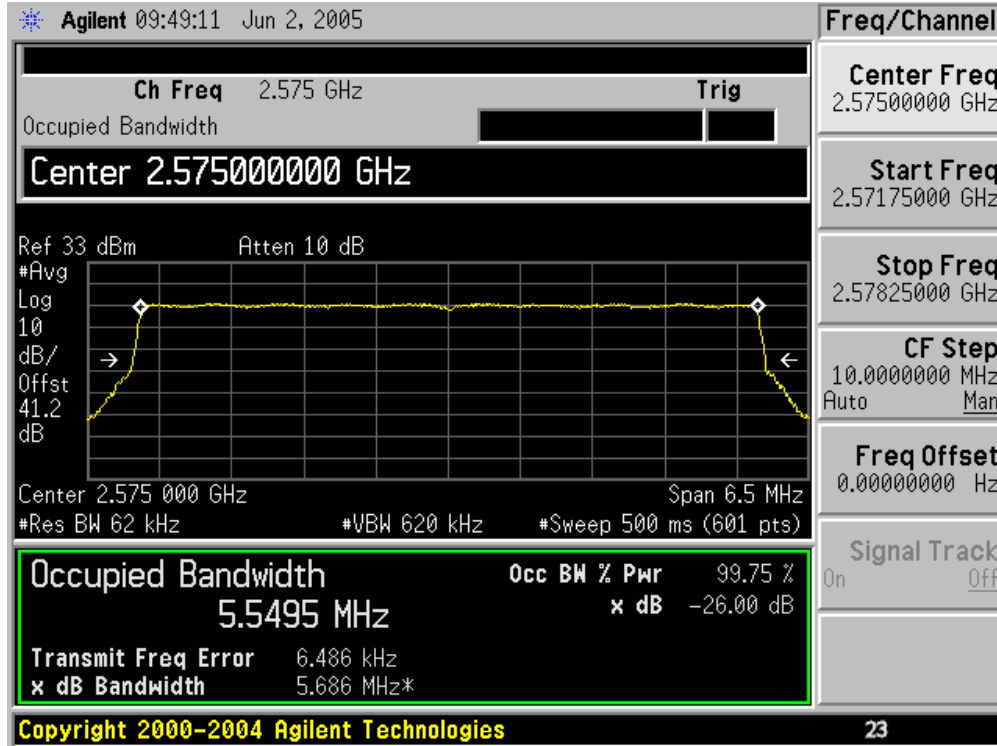
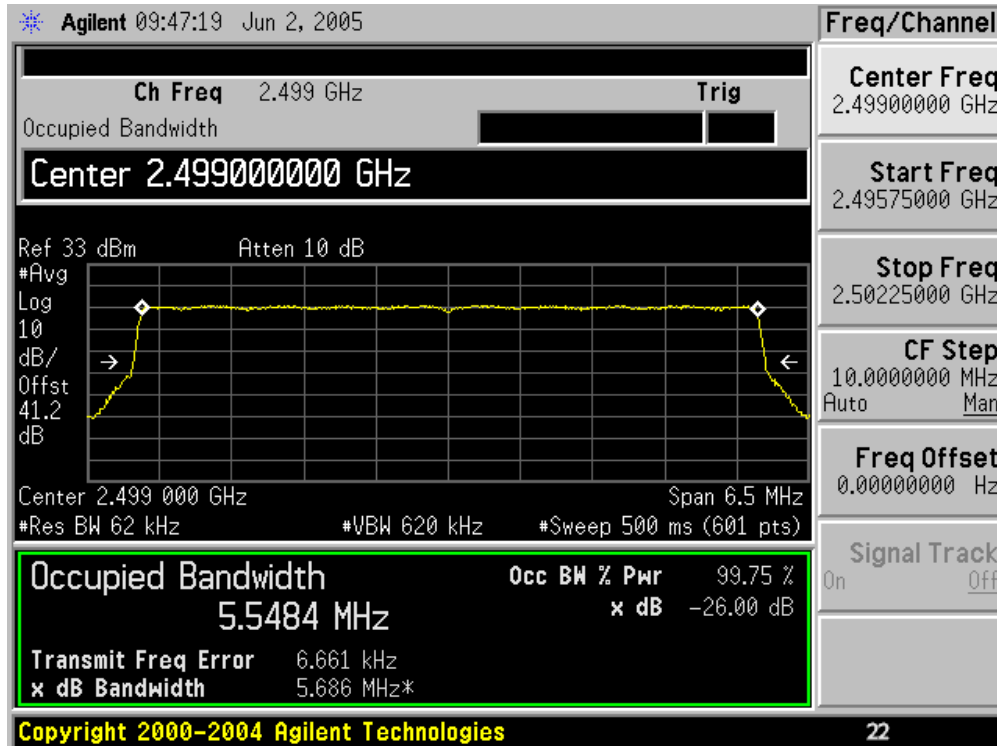

Emission Bandwidth 6.0 MHz Channels/4-QAM (Cont'd)

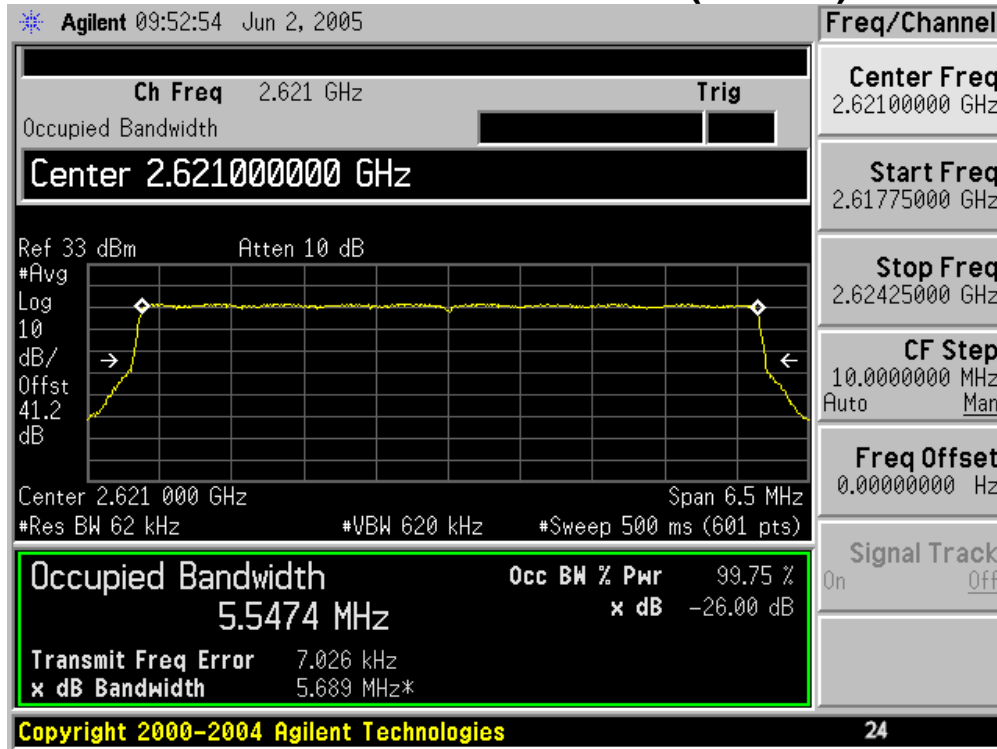

Emission Bandwidth 6.0 MHz Channels/16-QAM

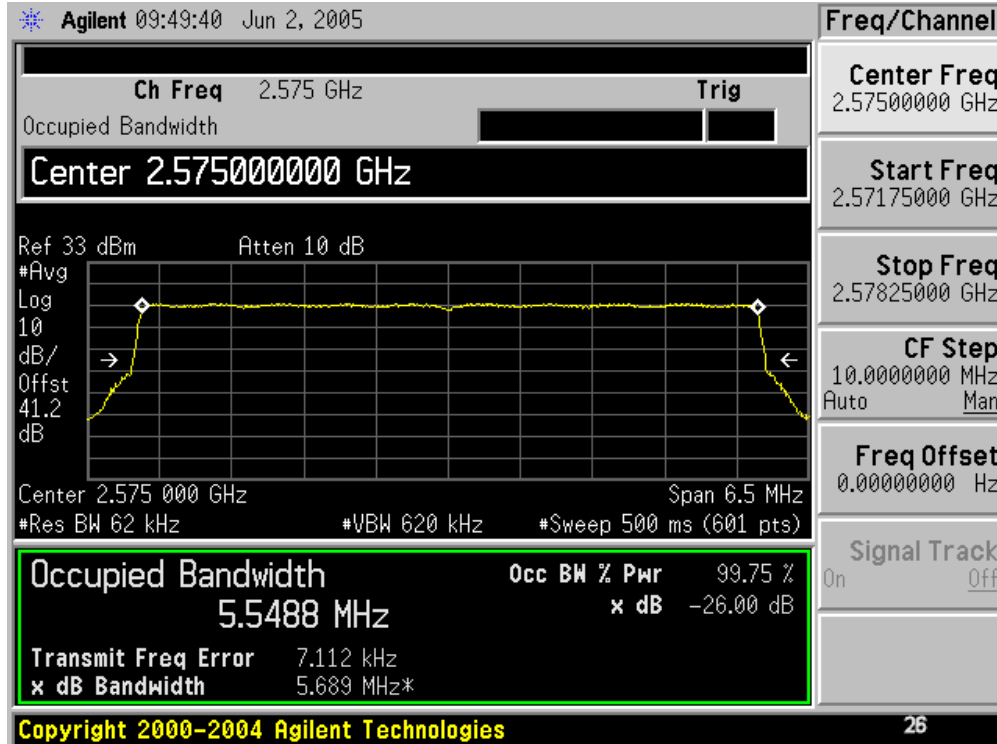
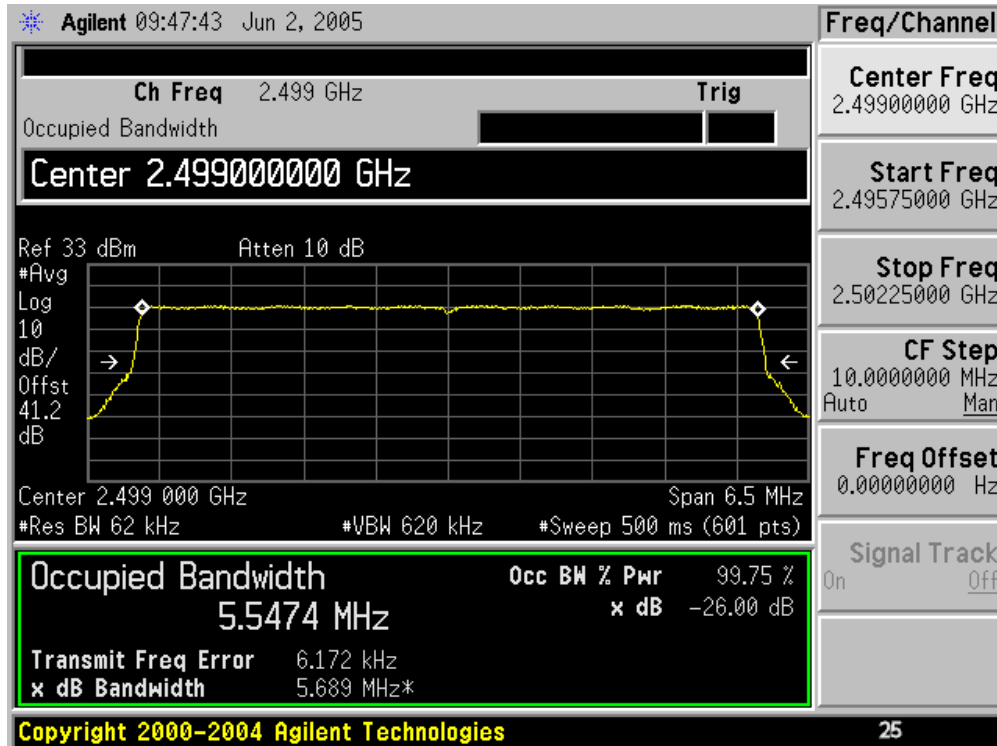

Emission Bandwidth 6.0 MHz Channels/16-QAM (Cont'd)

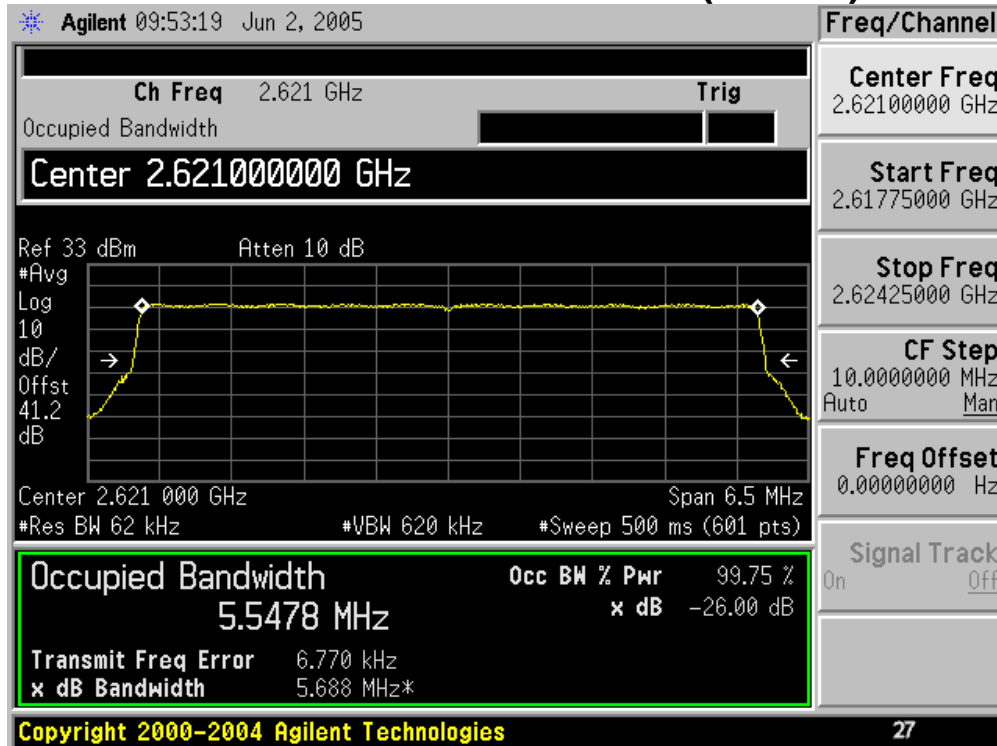

Emission Bandwidth 6.0 MHz Channels/64-QAM

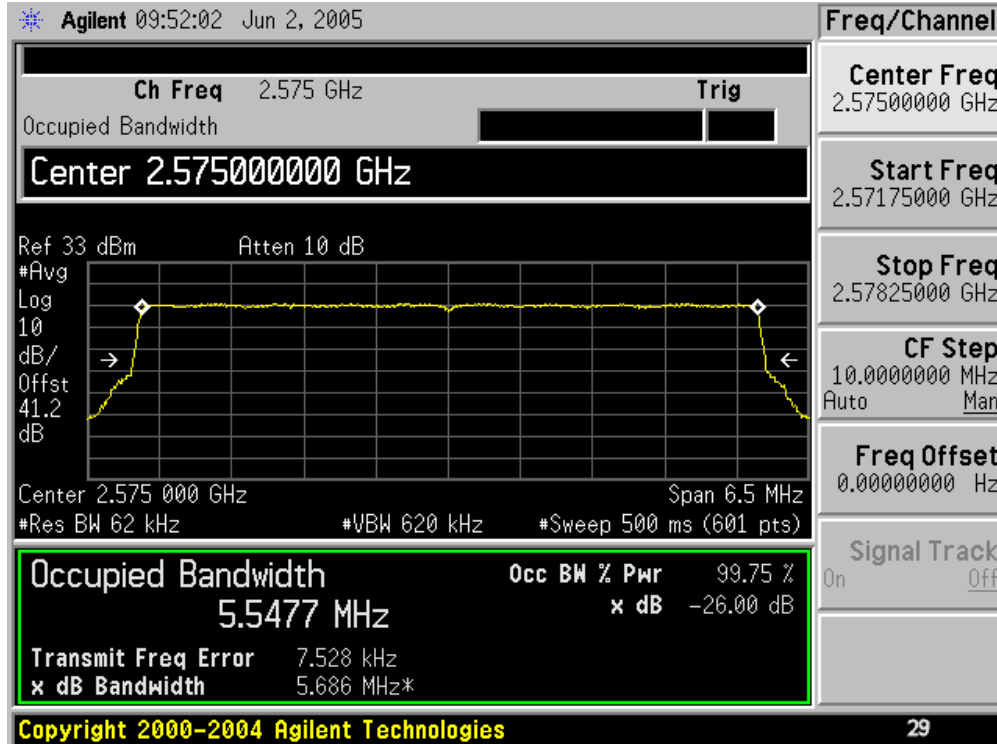
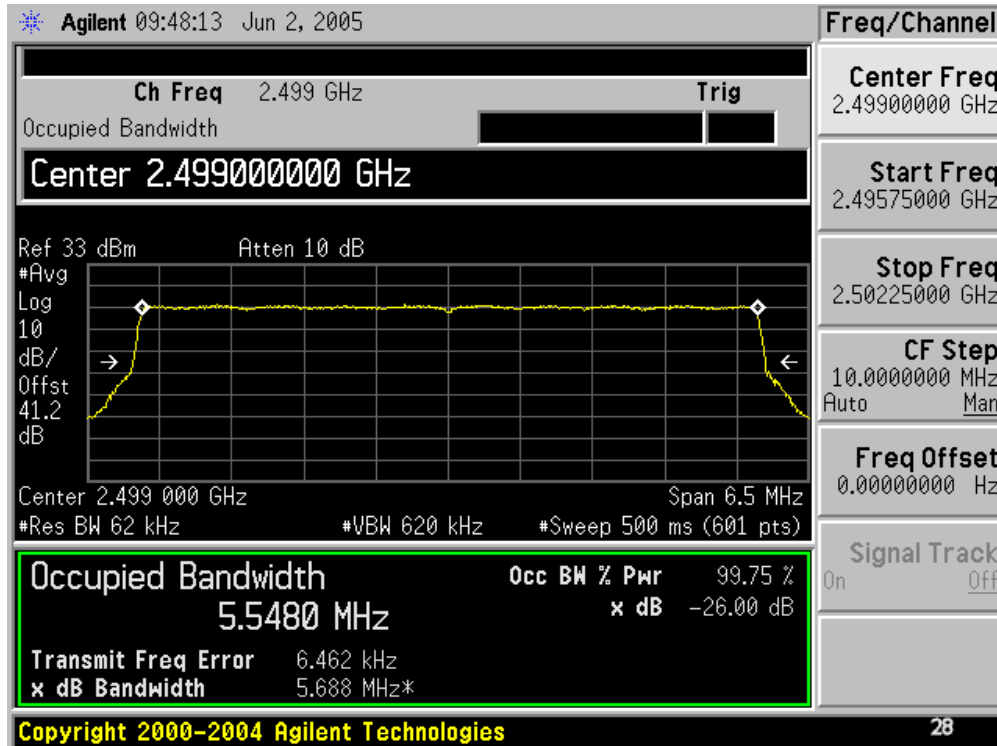

Emission Bandwidth 6.0 MHz Channels/64-QAM (Cont'd)

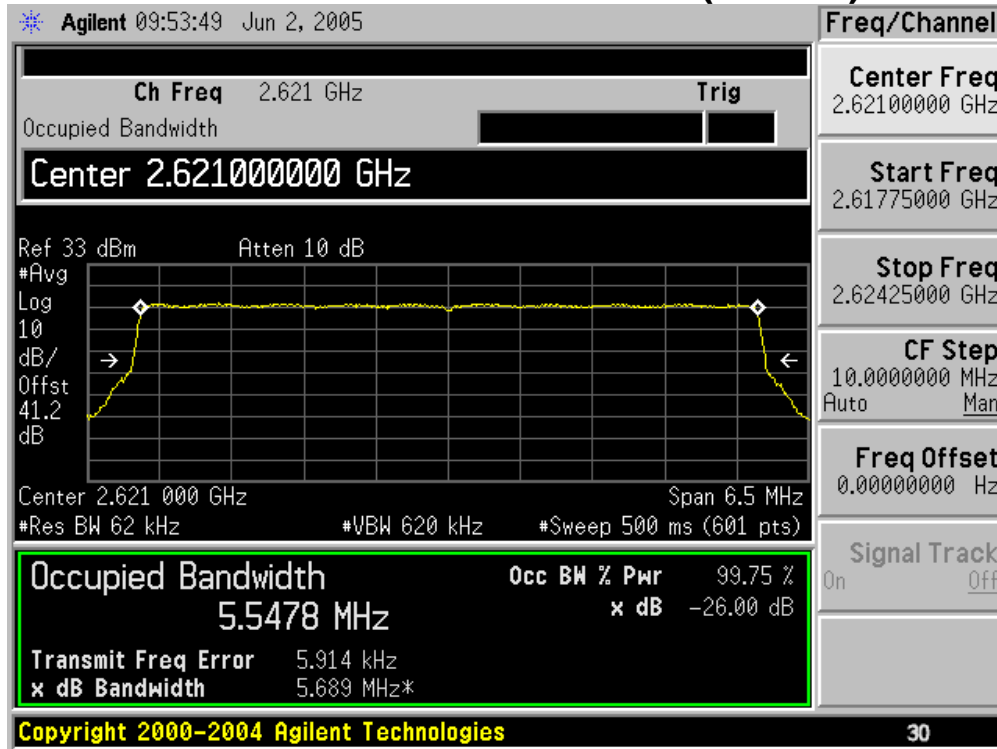

Spurious Emissions At Antenna Terminals

Rule Part Number: 2.1051, 2.1049, 2.1057

Frequency Range = 9 kHz to 26.50 GHz
Attenuation (dB) below the power (W) supplied to the antenna transmission line
Attenuation = $43 + 10 \log P$, or 70 dBc, whichever is less stringent
Attenuation = $43 + 10 \log(2) = 46$ dBc 2 watt transmit level
(equates to absolute level of -13 dBm)

Standard: TIA-603-B
TIA Standard, Land Mobile FM or PM Communications Equipment, Measurement and Performance Standards

Test Procedure: The Orthogonal Frequency Division Multiplexing (OFDM) modulated Time Division Duplex (TDD) RF transmission from the test unit is applied to a spectrum analyzer thru 41.2 dB of attenuation (coax and attenuators), or through an attenuator, notch filter and coax that was calibrated for RF loss at each harmonic frequency being tested. The transmission is recorded from 9 kHz to 26.5 GHz. The transmitter is enabled in test mode with the attached computer. The RF loss of the attenuators and coax was measured and is included in the spectrum analyzer offset level for the specific measurement being recorded. Measurements are performed at frequencies across the band and channel bandwidths (5.5 MHz and 6 MHz). All measurements utilized 4-QAM modulation. One data plot from each channel bandwidth is included for tests below the BRS/EBS frequency band. All channels measured had similar looking spectral plots. The second harmonic of each tested frequency is shown for emissions. The worst-case channel for second harmonic was chosen to show compliance for harmonics three thru ten. The other channels tested have similar or lower harmonic levels.

Test Conditions: Frequencies =
5.5 MHz channel: 2504.75, 2565.25, 2626.75, and 2687.25 MHz
6.0 MHz channel: 2499, 2575, and 2621 MHz
Second harmonic of all test frequencies included, 3rd thru 10th harmonics of 2504.75 MHz (worst case value) included at end. All other frequencies had similar results.
Temperature = 25 °C
Supply Voltage = 19.5 VDC nominal to DUT

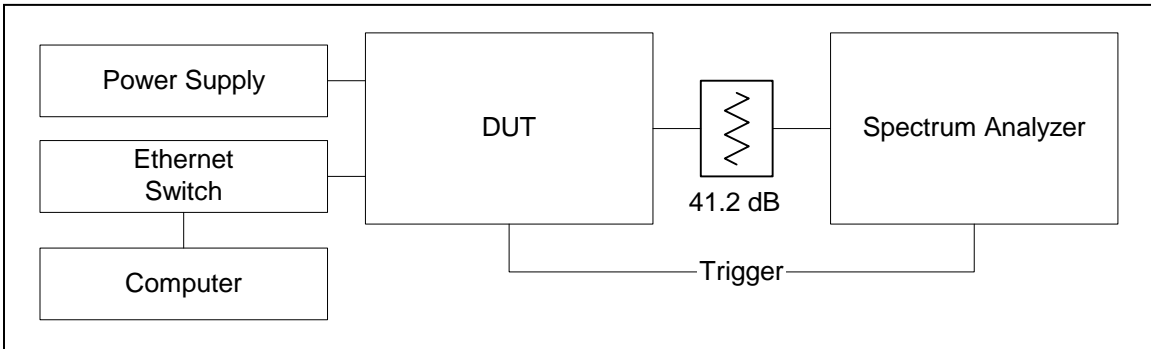

Spurious Emissions Test Setup

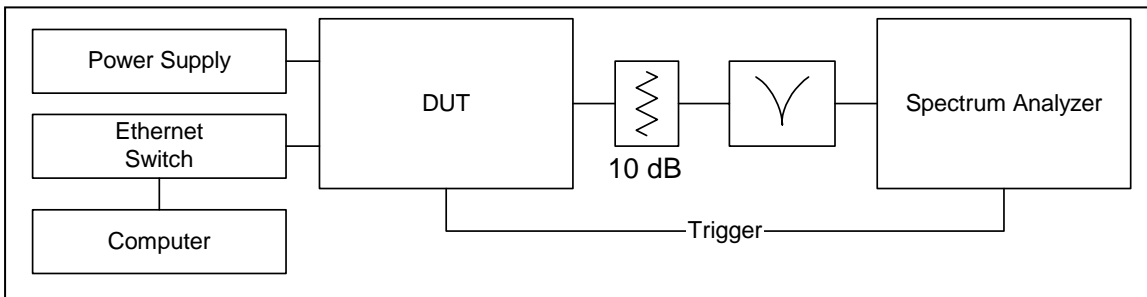

Harmonic Emissions Test Setup

Test Results: Passes conducted emissions from 9 kHz to 26.5 GHz.

Spurious Emissions At Antenna Terminals Spectrum Analyzer Plots

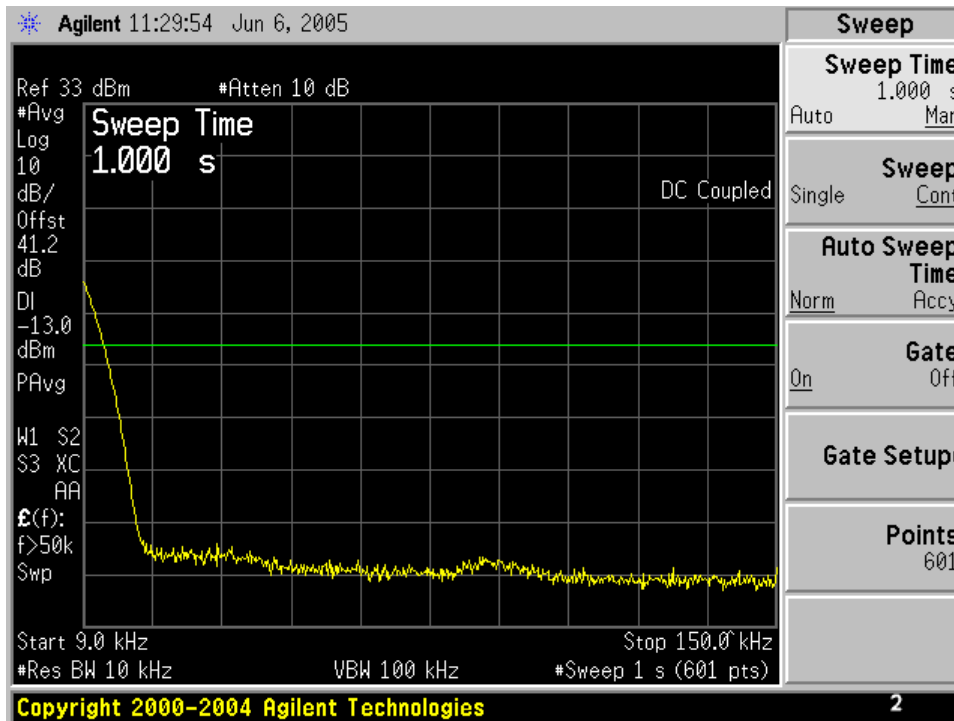

9 kHz – 150 kHz (2575 MHz / 6 MHz Channel)

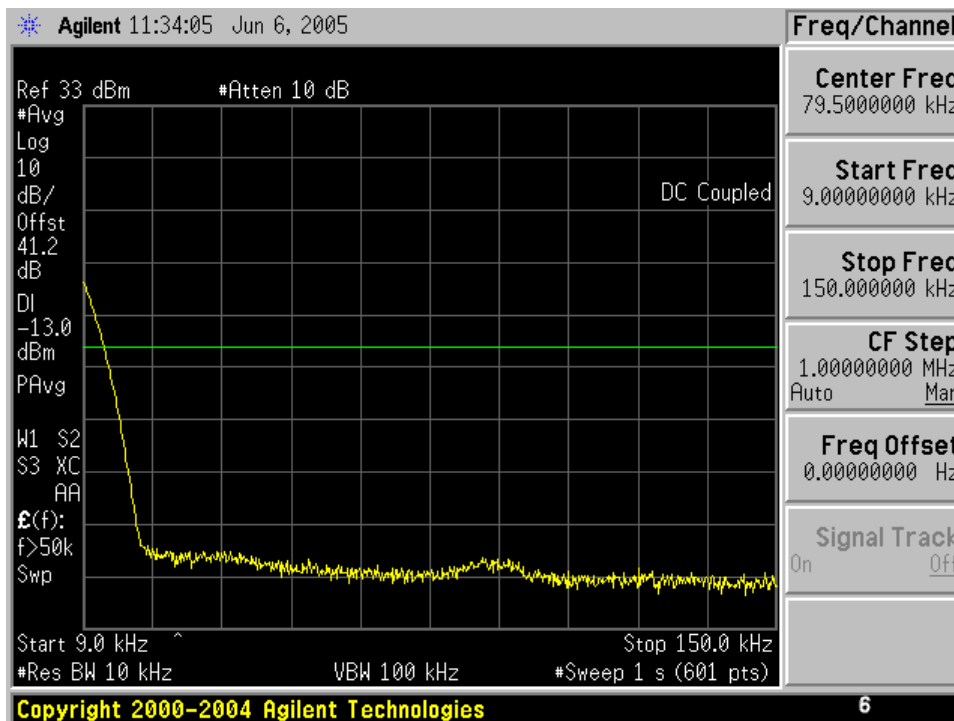

9 kHz – 150 kHz (2626.75 MHz / 5.5 MHz Channel)

Spurious Emissions Plots (Cont'd)

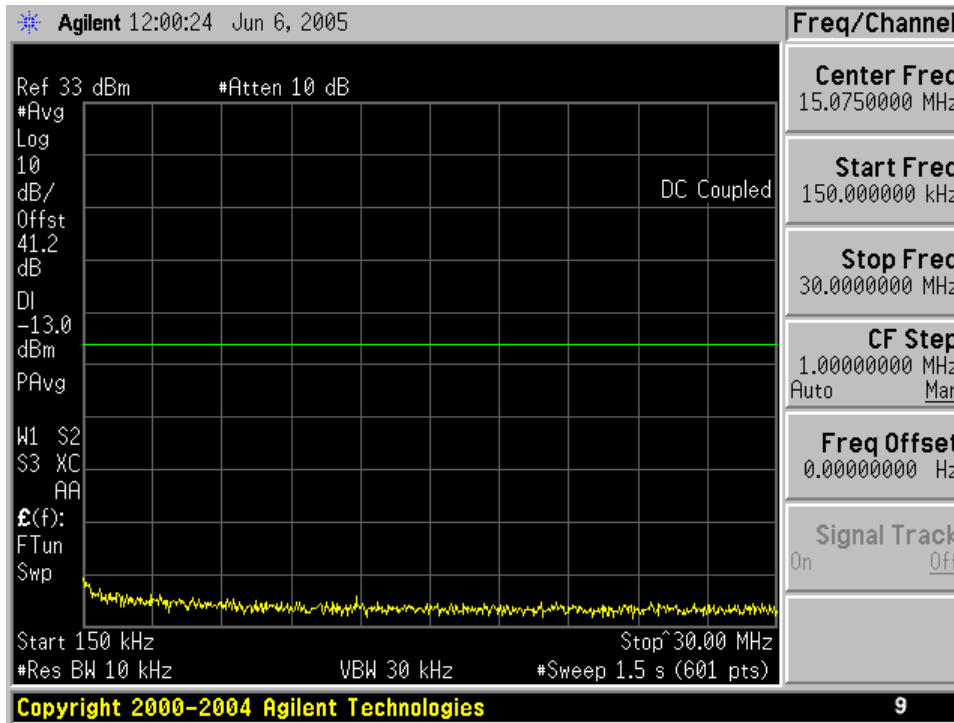

150 kHz – 30 MHz (2575 MHz / 6 MHz Channel)

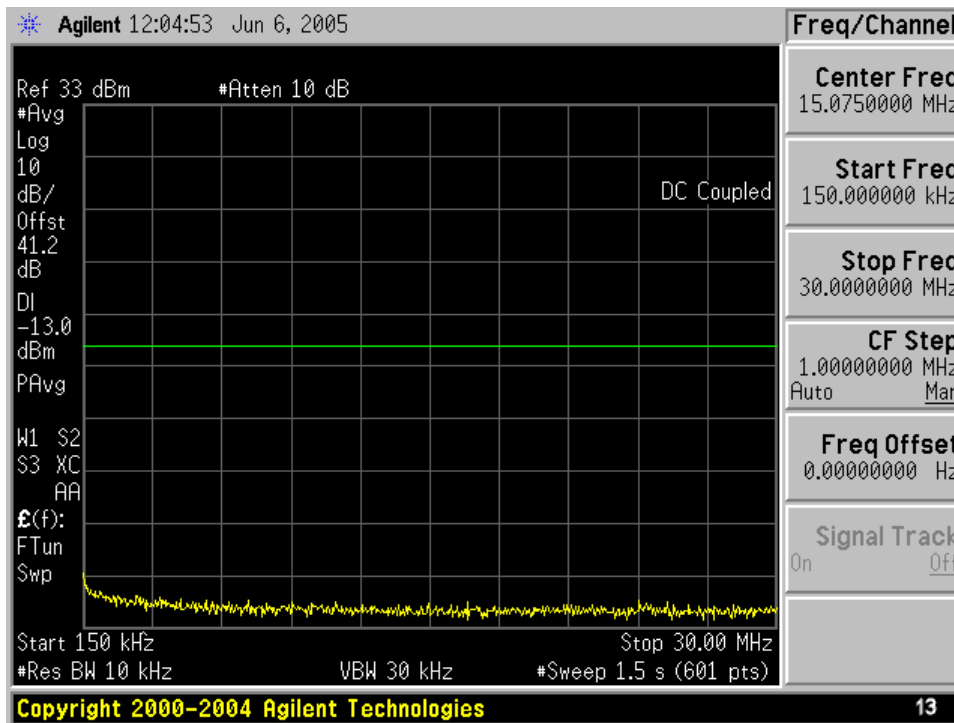

150 kHz – 30 MHz (2626.75 MHz / 5.5 MHz Channel)

Spurious Emissions Plots (Cont'd)

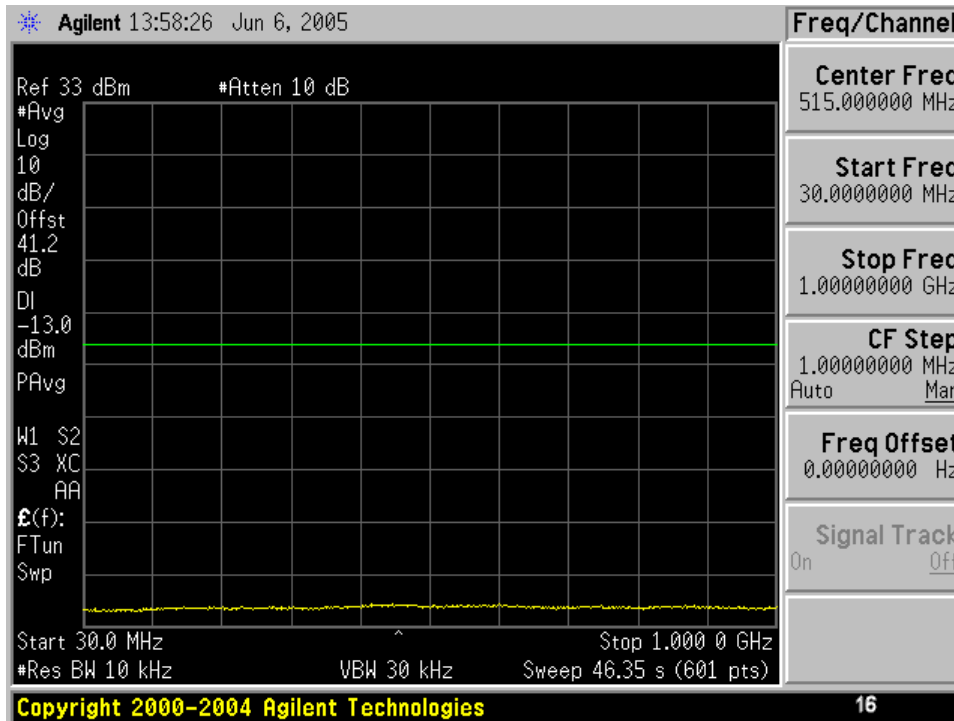

30 MHz – 1 GHz (2575 MHz / 6 MHz Channel)

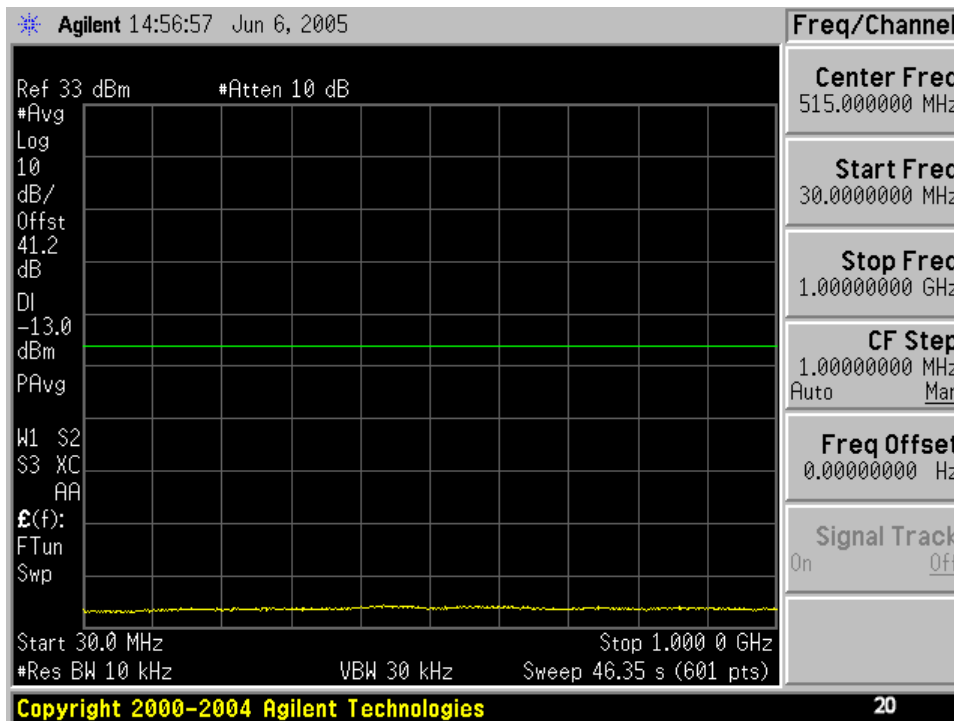

30 MHz – 1 GHz (2626.75 MHz / 5.5 MHz Channel)

Spurious Emissions Plots (Cont'd)

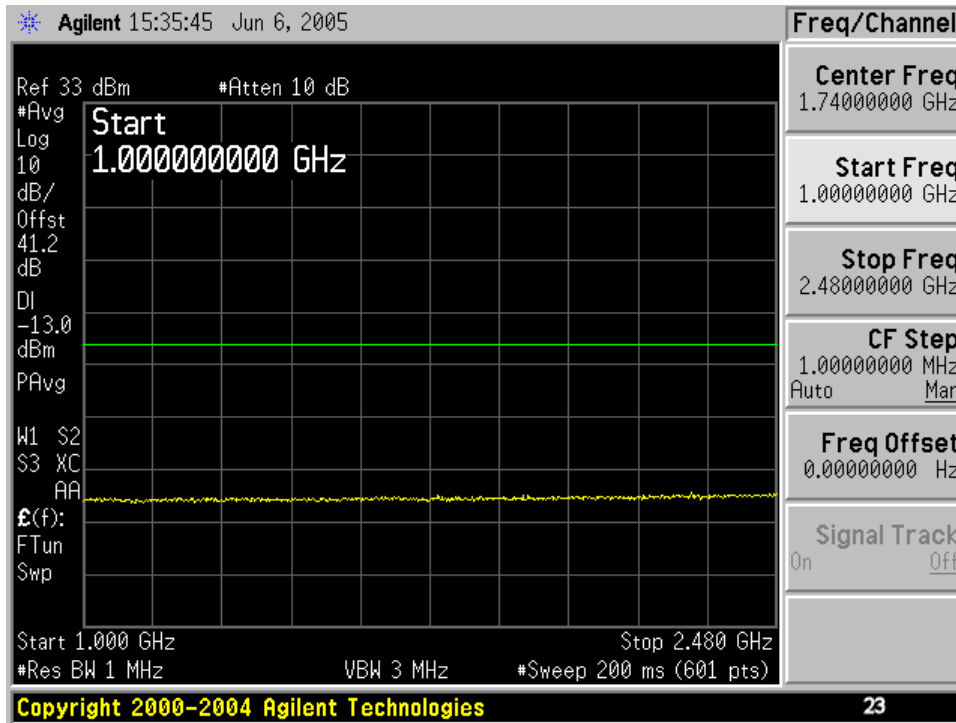

1 GHz – 2.48 GHz (2575 MHz / 6 MHz Channel)

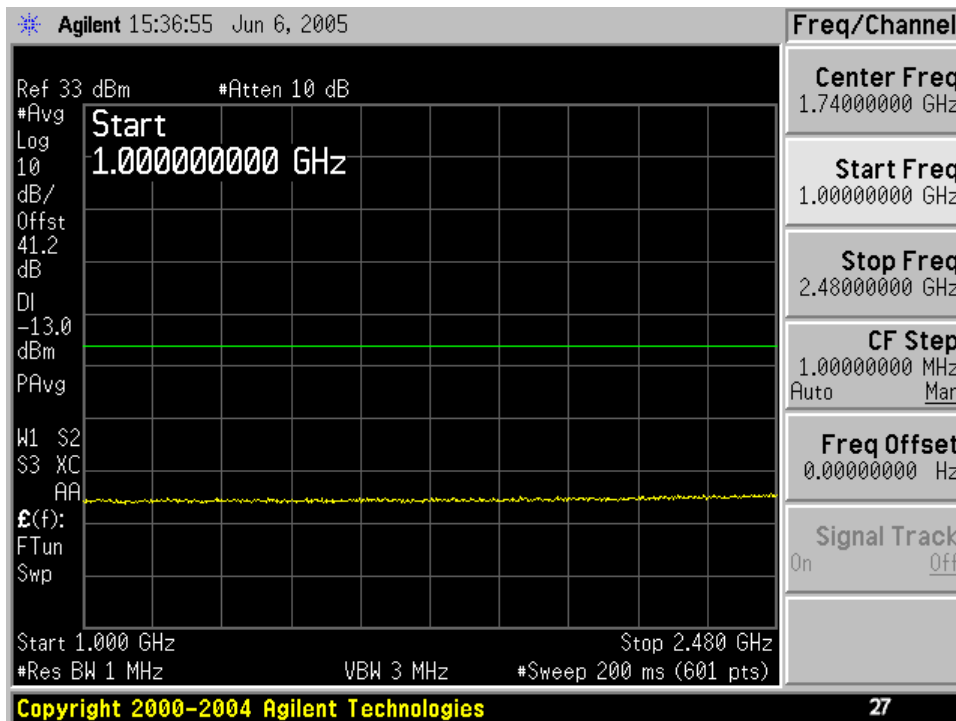

1 GHz – 2.48 GHz (2626.75 MHz / 5.5 MHz Channel)

Spurious Emissions Plots (Cont'd)

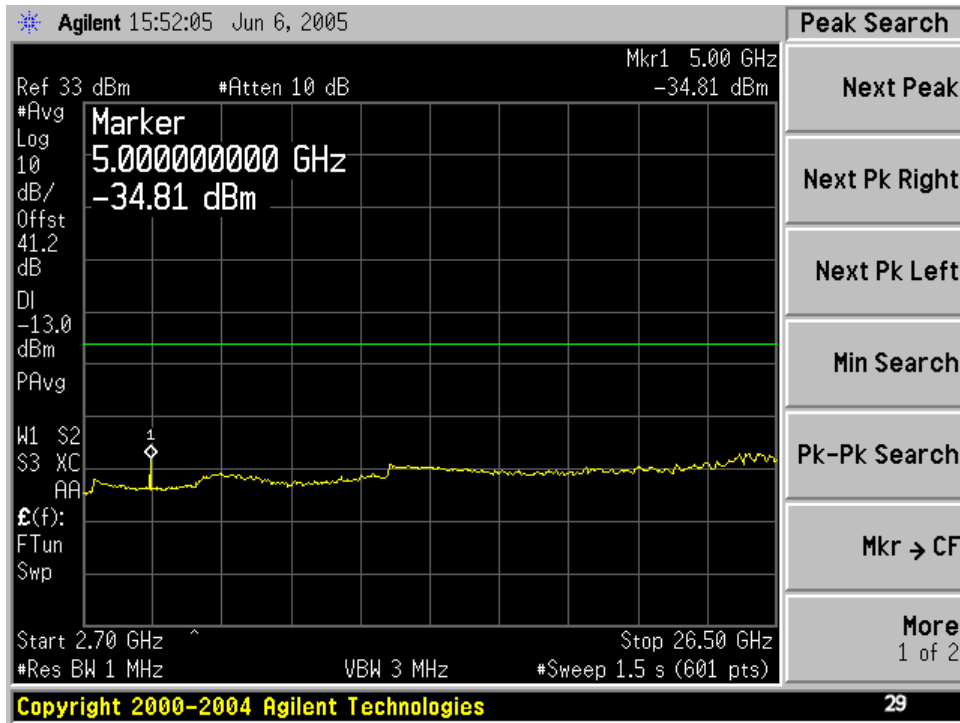

2.7 GHz – 26.5 GHz (2499 MHz / 6 MHz Channel)

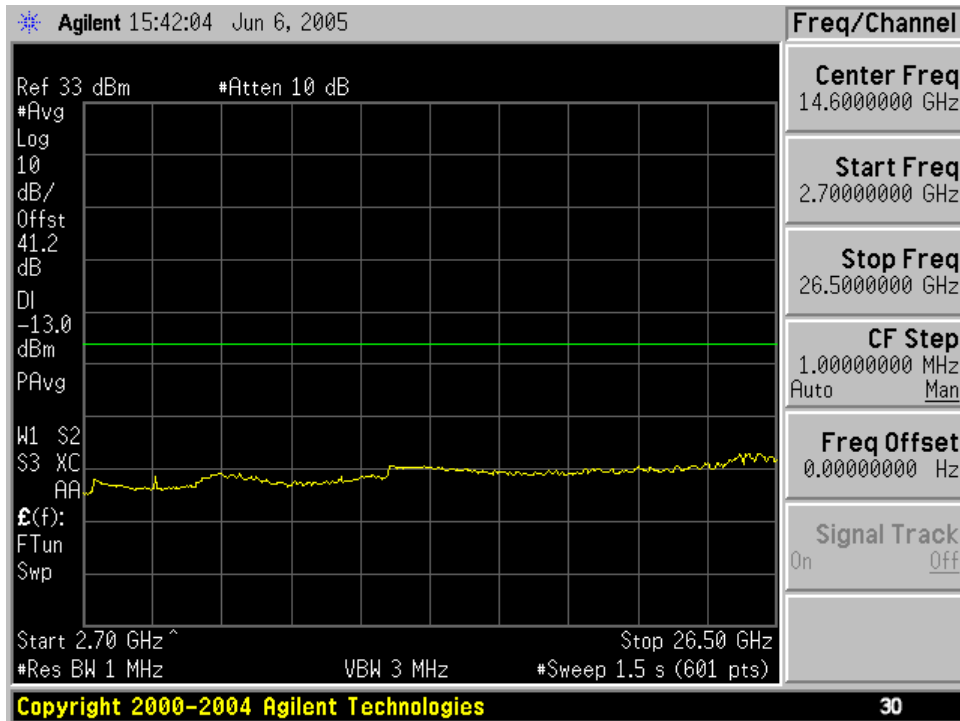

2.7 GHz – 26.5 GHz (2575 MHz / 6 MHz Channel)

Spurious Emissions Plots (Cont'd)

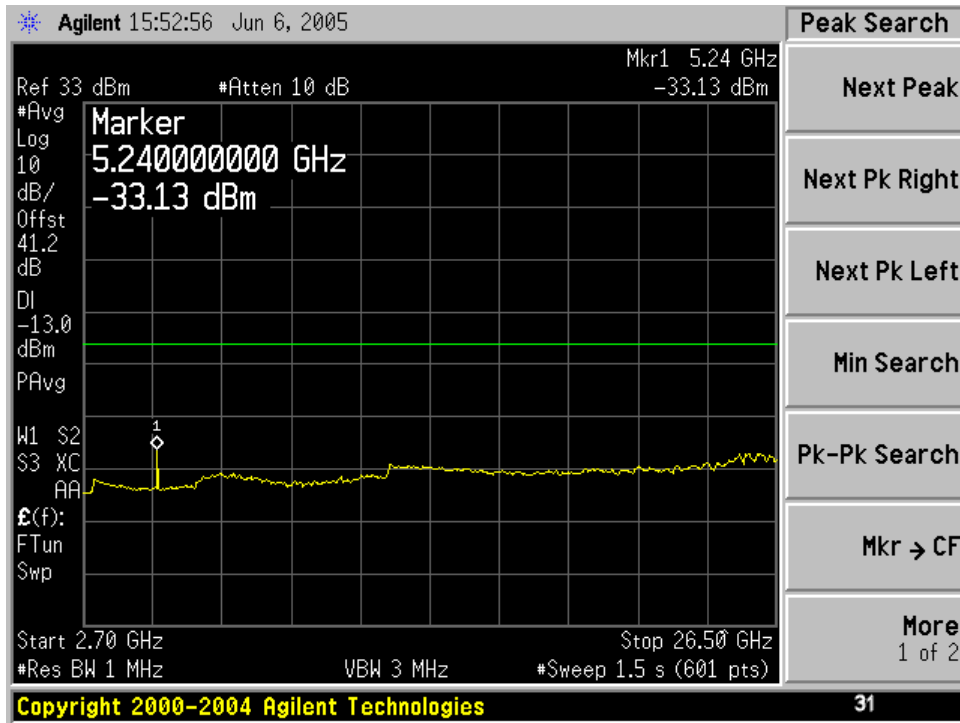

2.7 GHz – 26.5 GHz (2621 MHz / 6 MHz Channel)

Spurious Emissions Plots (Cont'd)

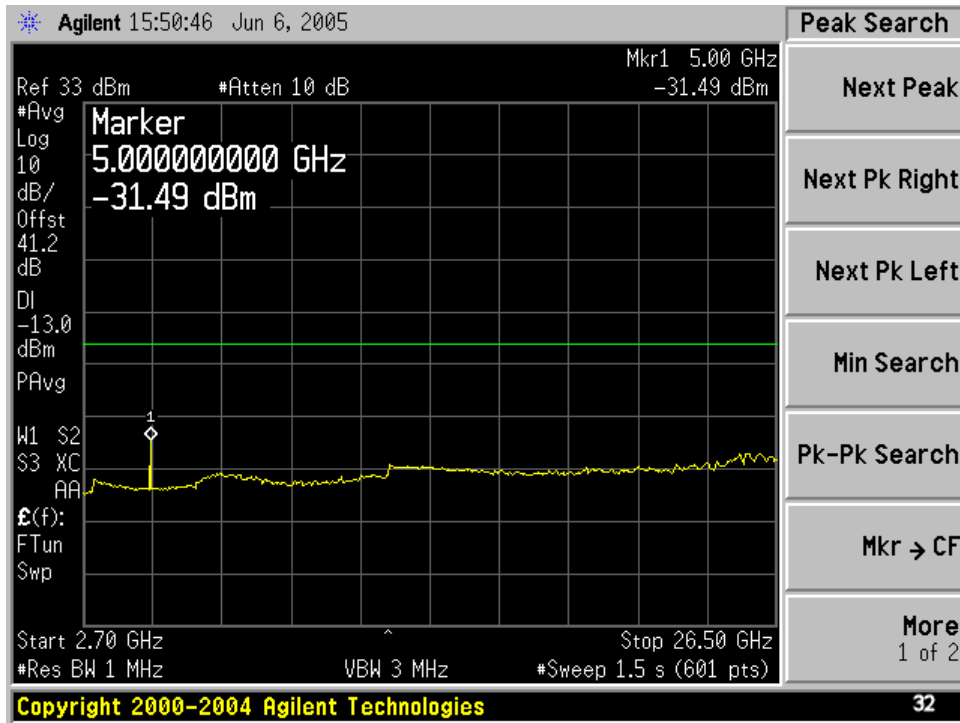

2.7 GHz – 26.5 GHz (2504.75 MHz / 5.5 MHz Channel)

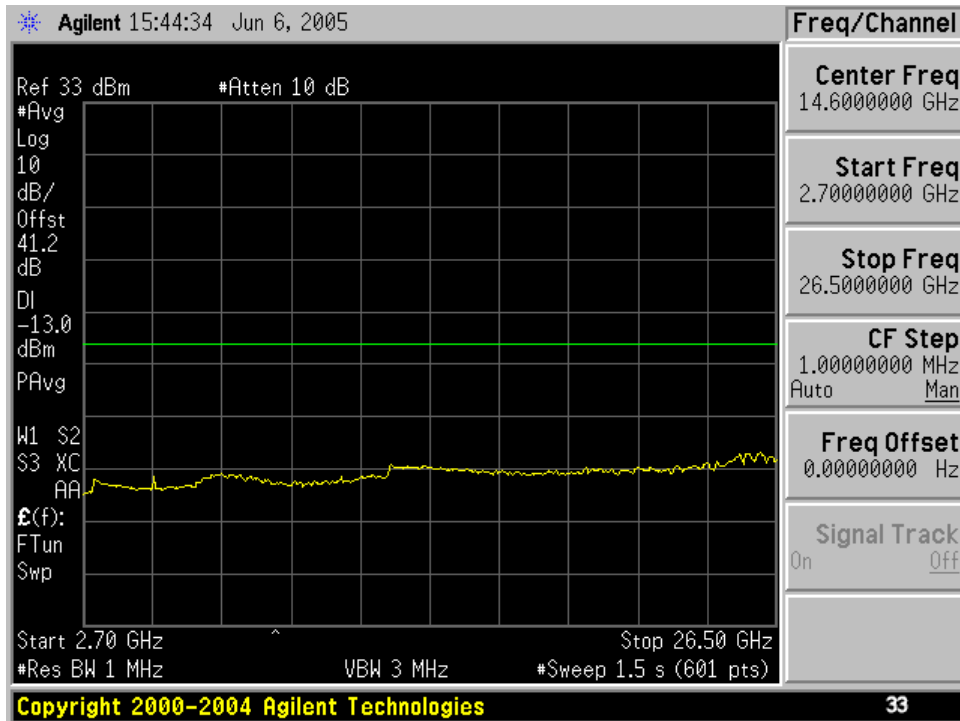

2.7 GHz – 26.5 GHz (2565.25 MHz / 5.5 MHz Channel)

Spurious Emissions Plots (Cont'd)

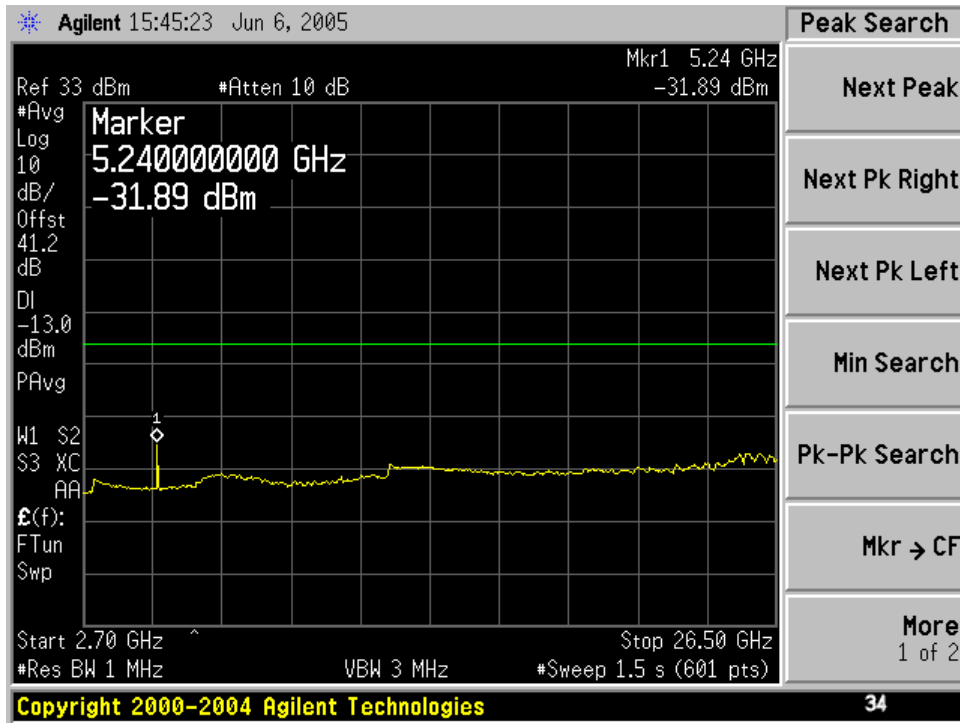

2.7 GHz – 26.5 GHz (2626.75 MHz / 5.5 MHz Channel)

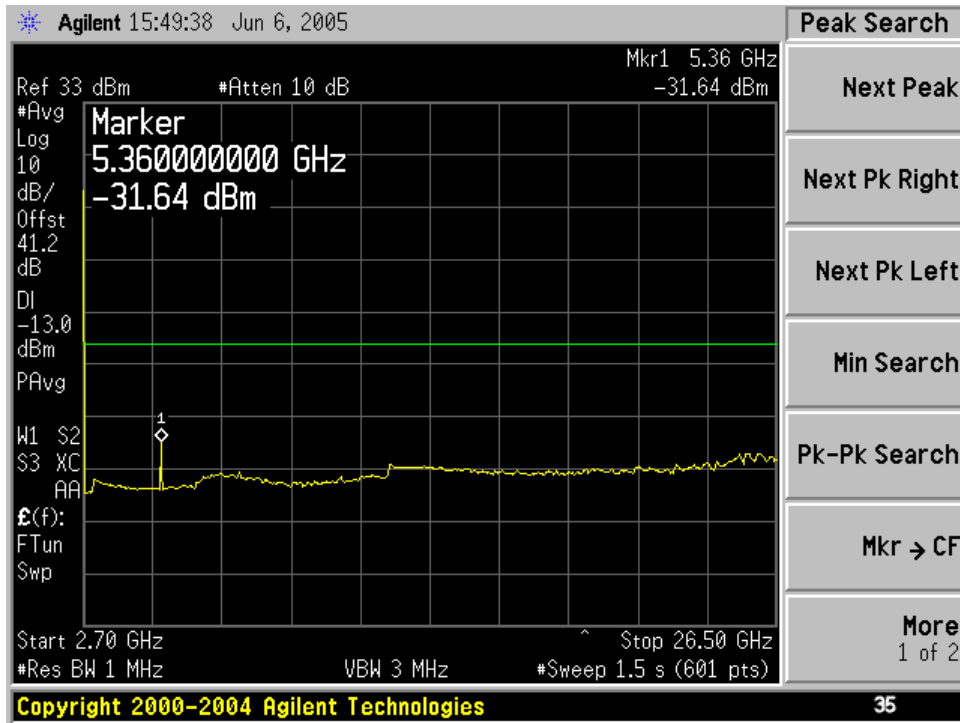

2.7 GHz – 26.5 GHz (2687.25 MHz / 5.5 MHz Channel)

Spurious Emissions Plots (Cont'd)

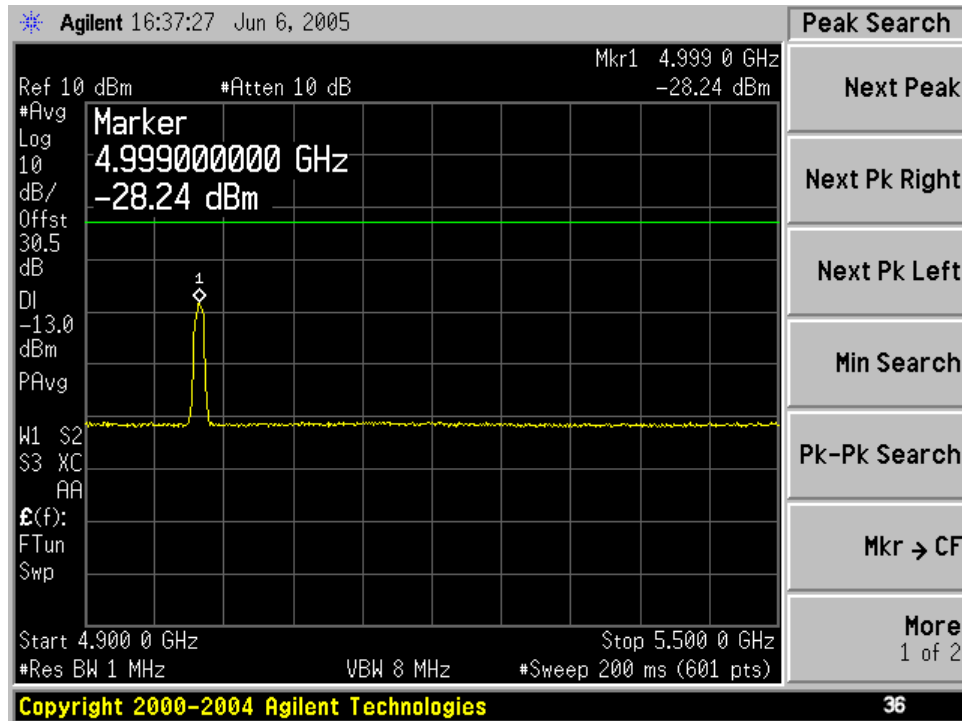

4.992 GHz – 5.38 GHz (2499 MHz / 6 MHz Channel / 2nd Harmonic)

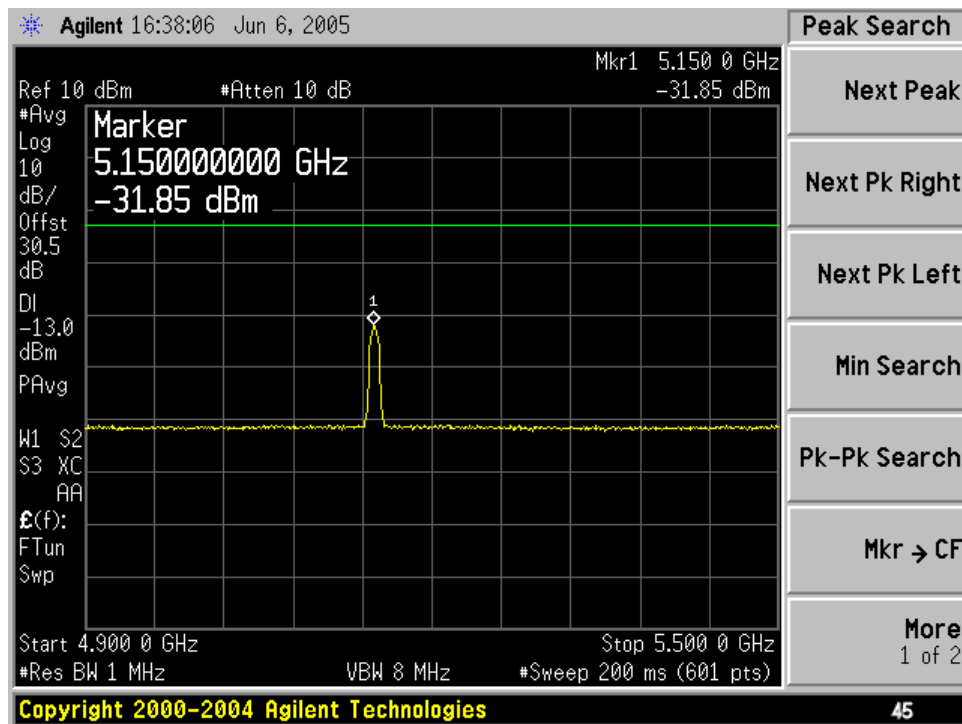

4.992 GHz – 5.38 GHz (2575 MHz / 6 MHz Channel / 2nd Harmonic)

Spurious Emissions Plots (Cont'd)

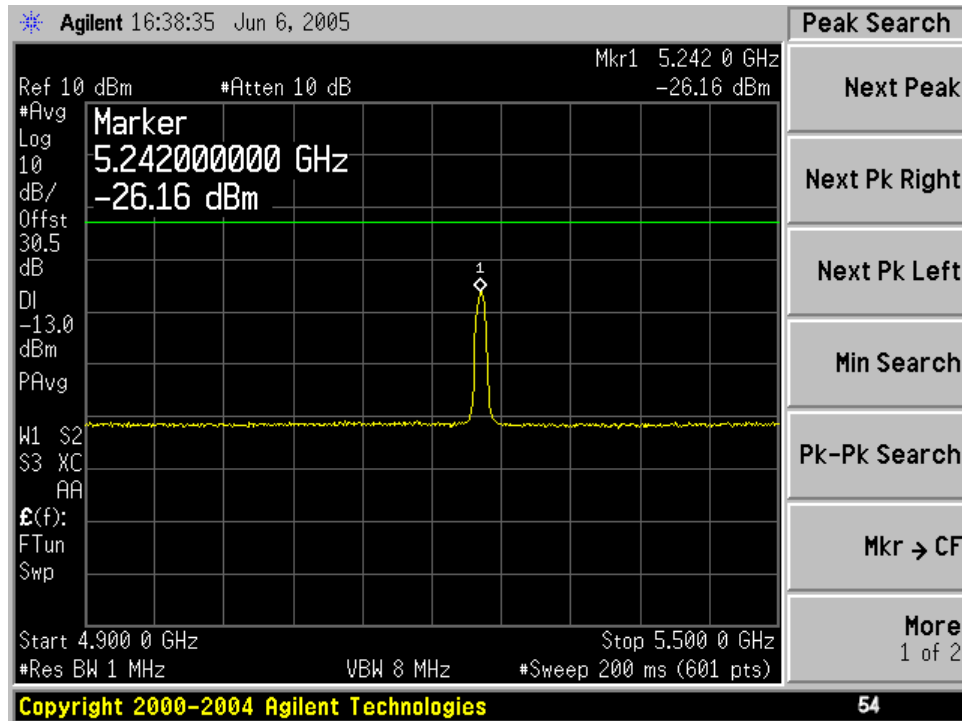

4.992 GHz – 5.38 GHz (2621 MHz / 6 MHz Channel / 2nd Harmonic)

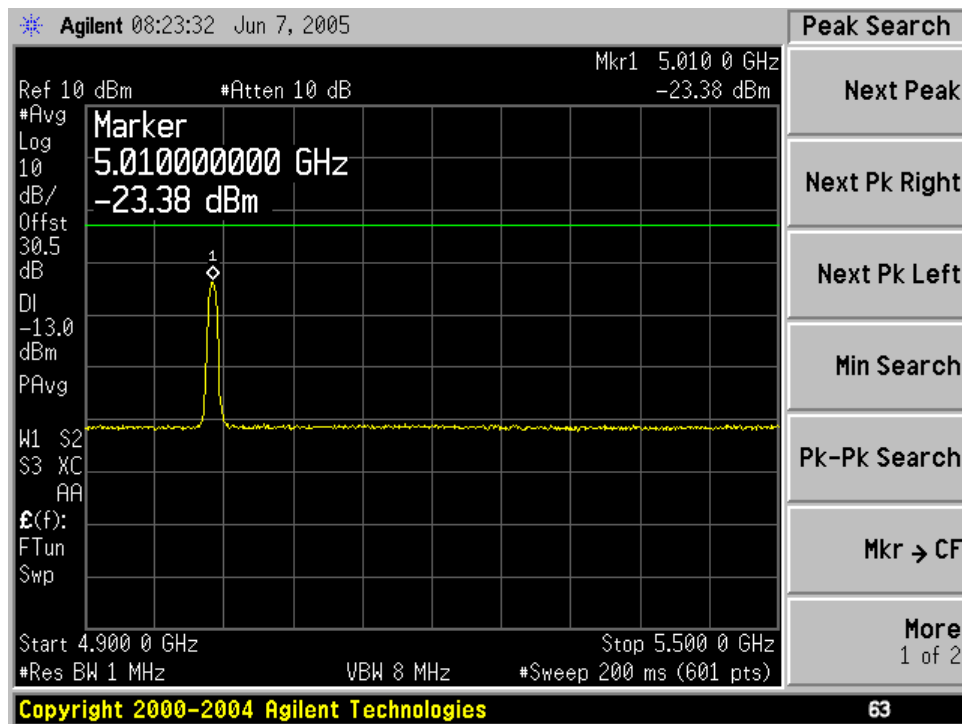

4.992 GHz – 5.38 GHz (2504.75 MHz / 5.5 MHz Channel / 2nd Harmonic)

Spurious Emissions Plots (Cont'd)

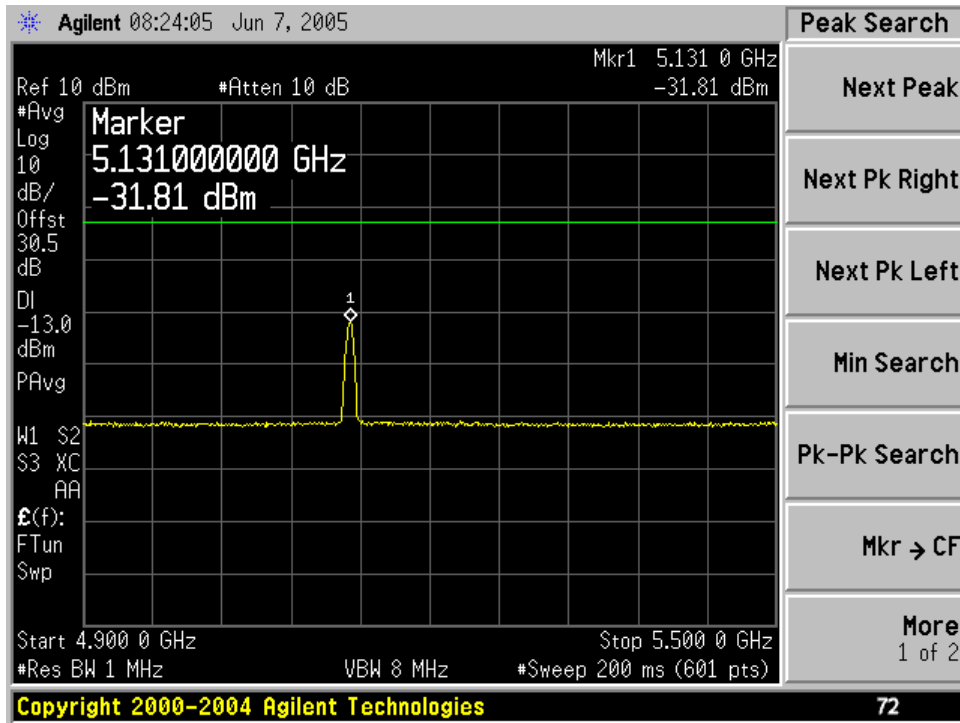

4.992 GHz – 5.38 GHz (2565.25 MHz / 5.5 MHz Channel / 2nd Harmonic)

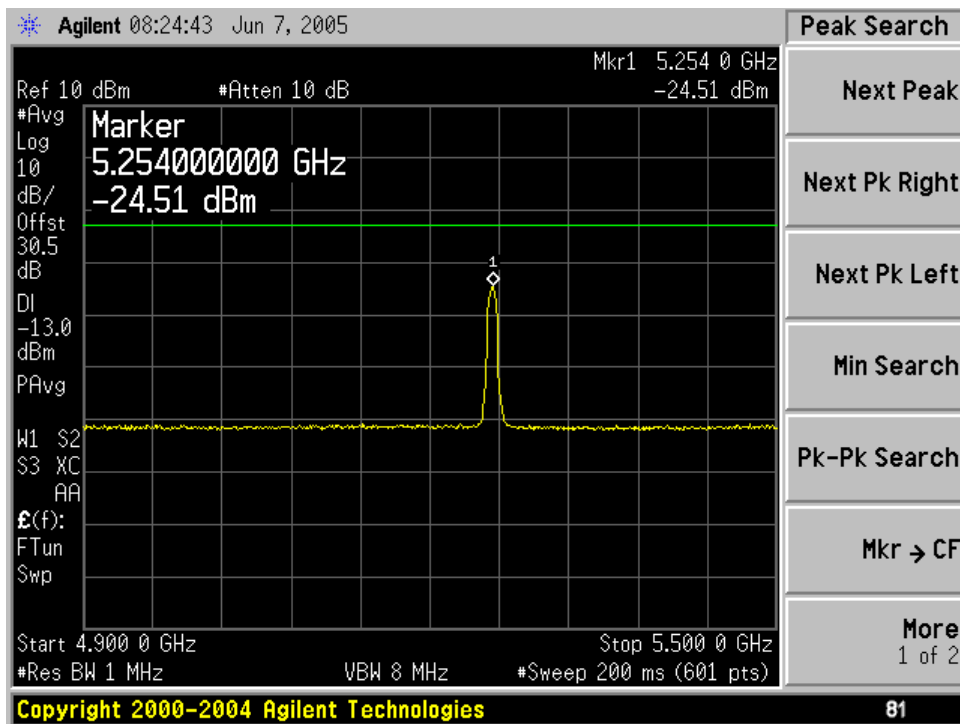

4.992 GHz – 5.38 GHz (2626.75 MHz / 5.5 MHz Channel / 2nd Harmonic)

Spurious Emissions Plots (Cont'd)

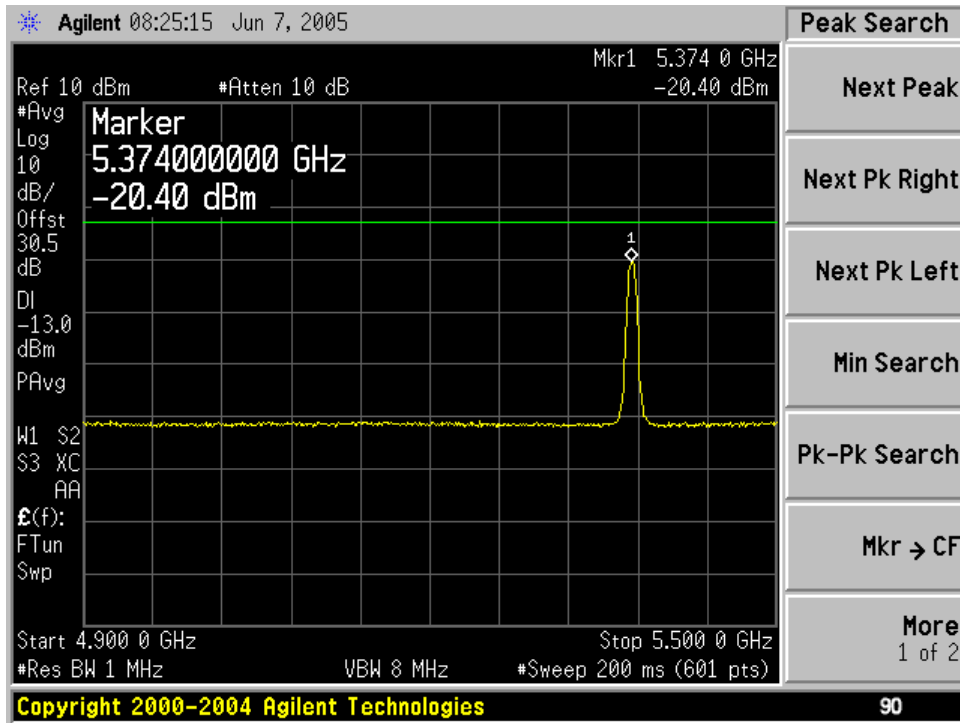

4.992 GHz – 5.38 GHz (2687.25 MHz / 5.5 MHz Channel / 2nd Harmonic)

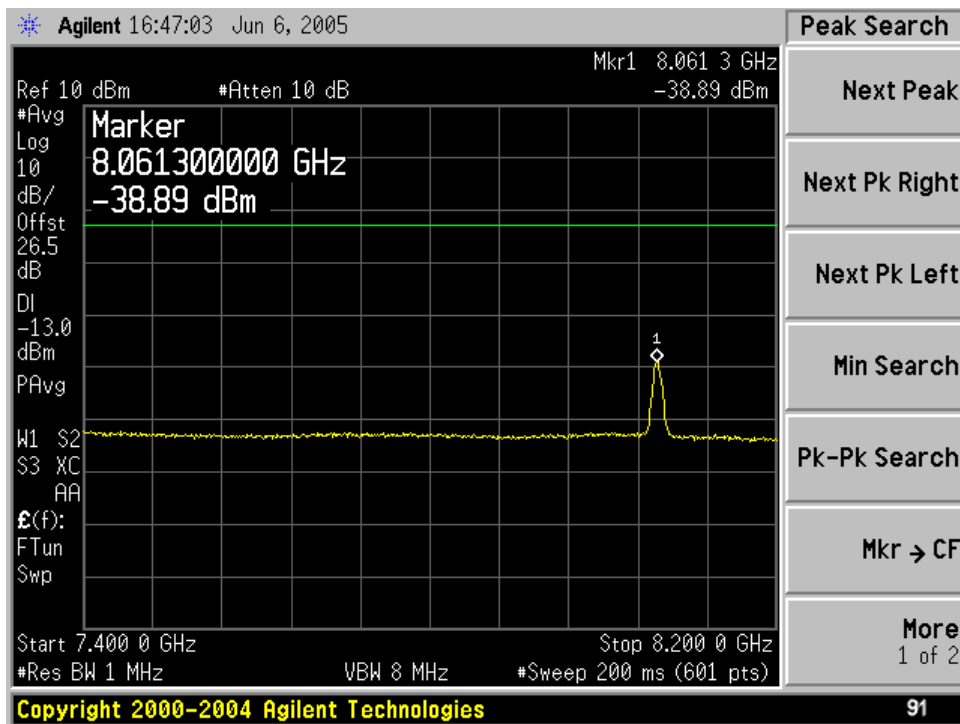

3rd Harmonic of 2687.25 MHz

Spurious Emissions Plots (Cont'd)

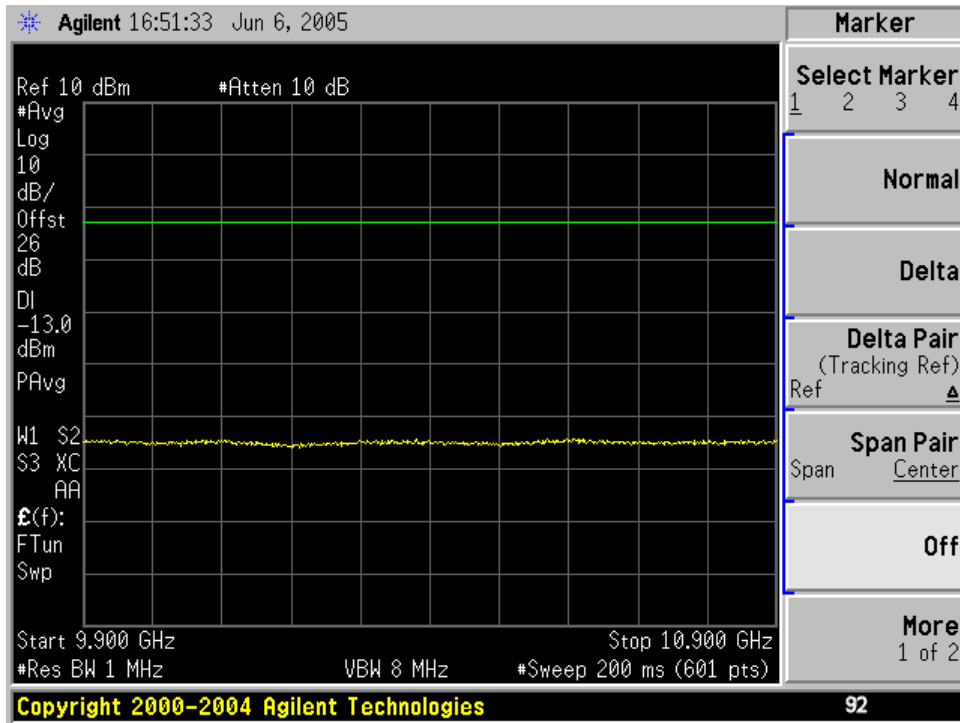

4th Harmonic of 2687.25 MHz

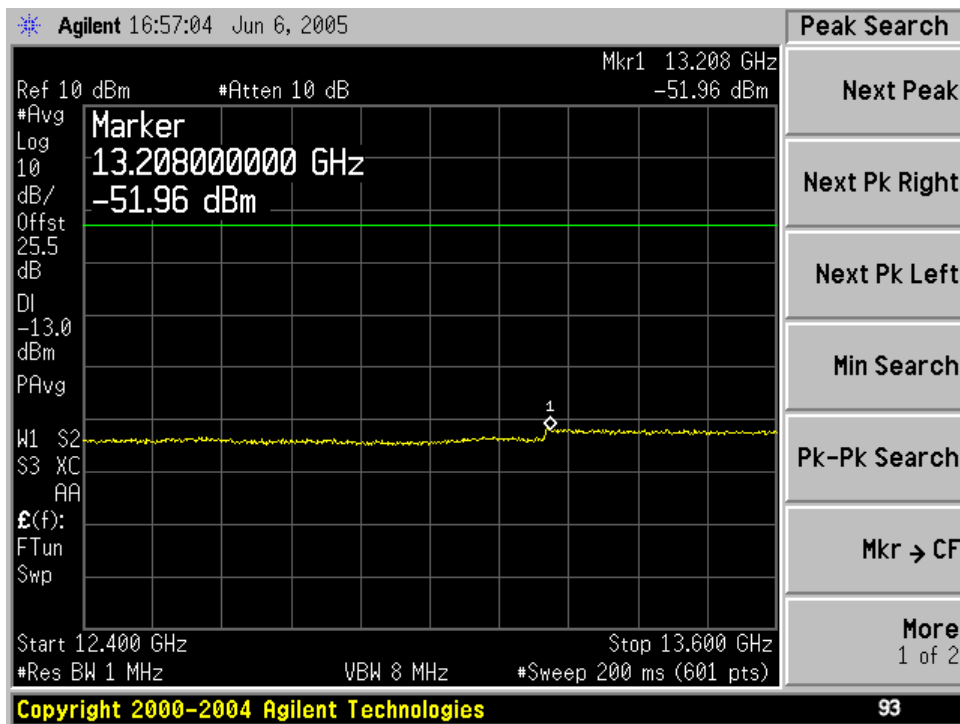

5th Harmonic of 2687.25 MHz

Spurious Emissions Plots (Cont'd)

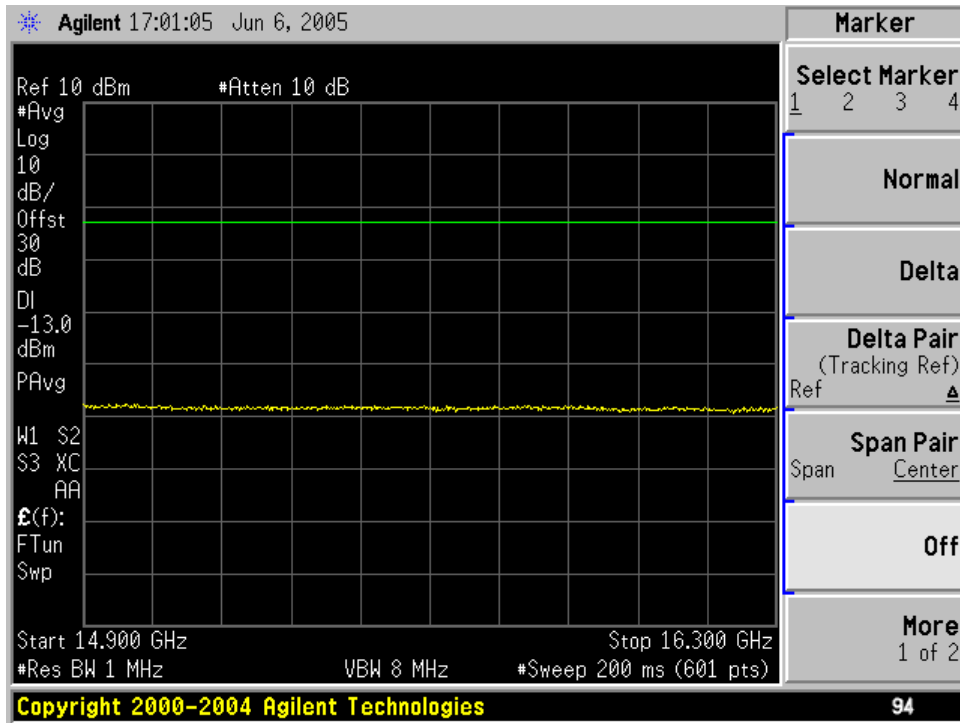

6th Harmonic of 2687.25 MHz

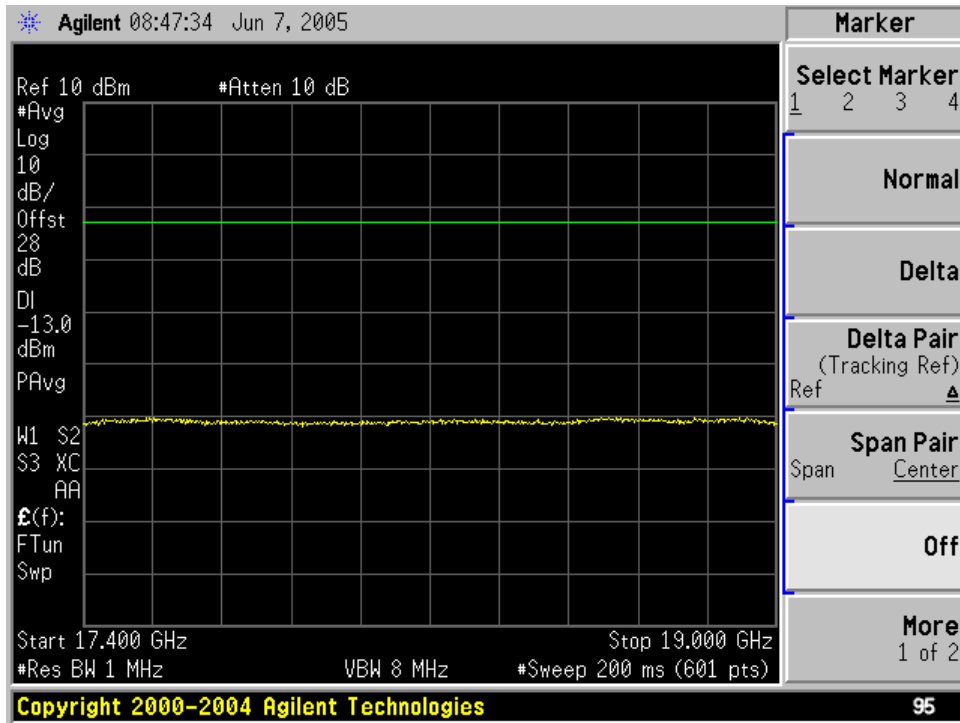

7th Harmonic of 2687.25 MHz

Spurious Emissions Plots (Cont'd)

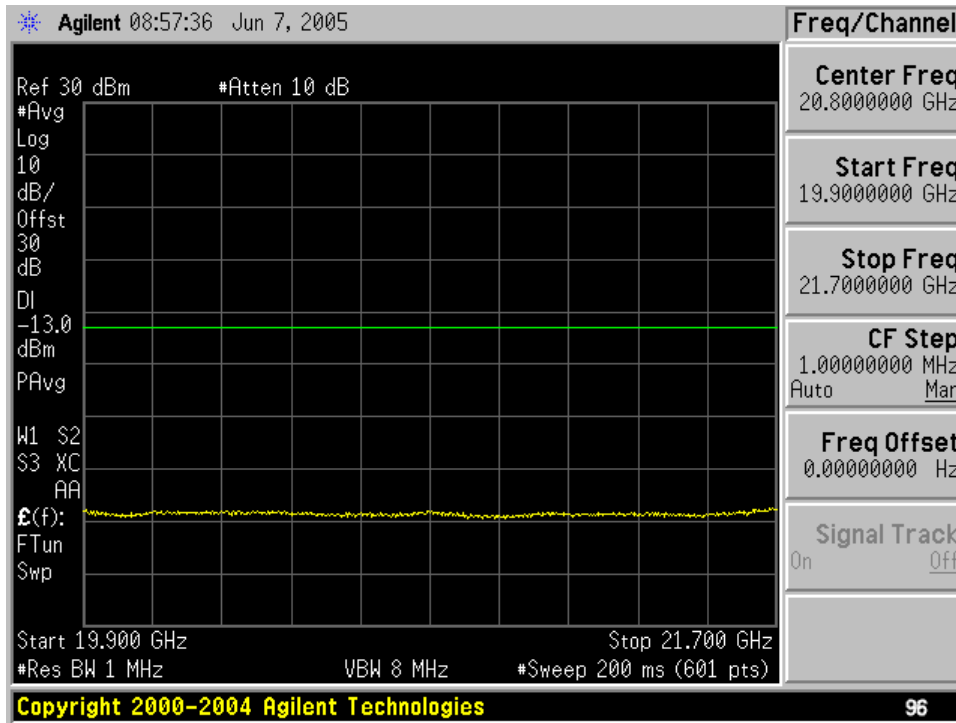

8th Harmonic of 2687.25 MHz

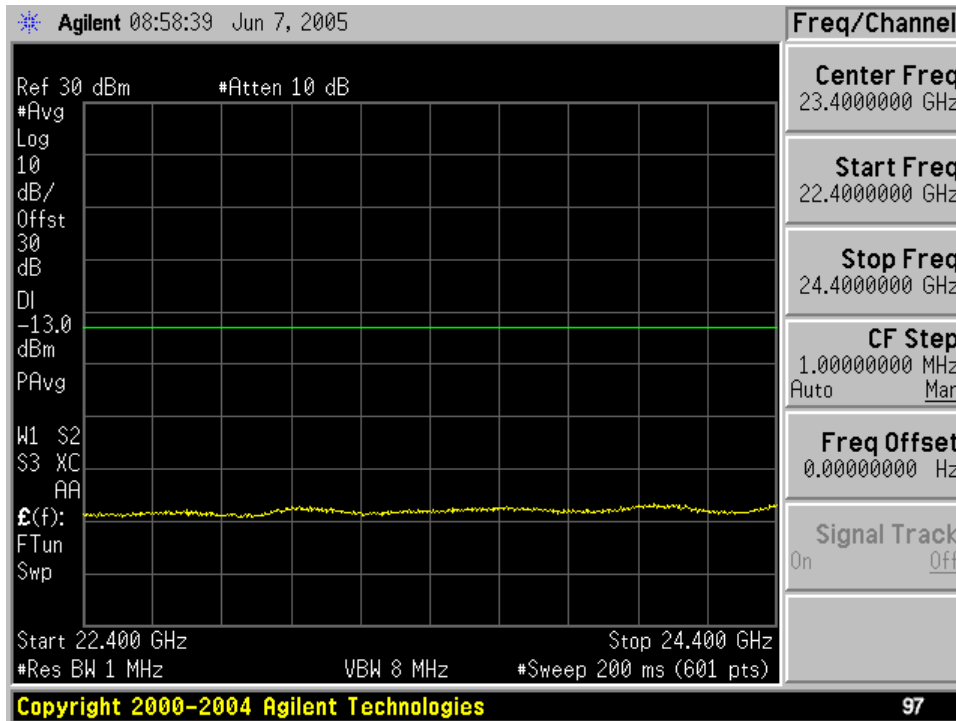

9th Harmonic of 2687.25 MHz

Spurious Emissions Plots (Cont'd)

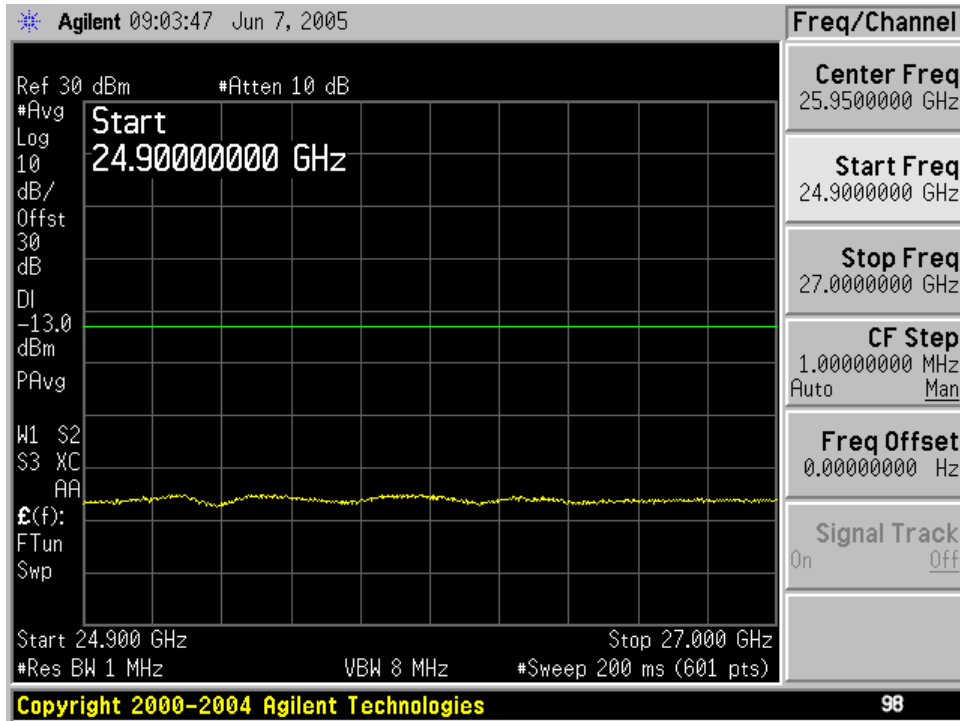

10th Harmonic of 2687.25 MHz

Frequency Stability Test

FCC Rule Part(s):

2.1055

Measurements required: Frequency stability:

(a) The frequency stability shall be measured with variation of ambient temperature as follows: (1) From -30° to $+50^{\circ}$ centigrade for all equipment except that specified in paragraphs (a) (2) and (3) of this section.

(b) Frequency measurements shall be made at the extremes of the specified temperature range and at intervals of not more than 10° centigrade through the range. A period of time sufficient to stabilize all of the components of the oscillator circuit at each temperature level shall be allowed prior to frequency measurement. The short term transient effects on the frequency of the transmitter due to keying (except for broadcast transmitters) and any heating element cycling normally occurring at each ambient temperature level also shall be shown.

(d) The frequency stability shall be measured with variation of primary supply voltage as follows: (1) Vary primary supply voltage from 85 to 115 percent of the nominal value for other than hand carried battery equipment. (3) The supply voltage shall be measured at the input to the cable normally provided with the equipment, or at the power supply terminals if cables are not normally provided. Effects on frequency of transmitter keying (except for broadcast transmitters) and any heating element cycling at the nominal supply voltage and at each extreme also shall be shown.

27.54

Frequency Stability:

The frequency stability shall be sufficient to ensure that the fundamental emissions stay within the authorized bands of operation.

Standard:

47CFR27.53(1)(3)

Test Procedure:

The frequency stability of the NextNet Wireless Outdoor Subscriber Unit fundamental oscillator is derived from the on board 20 MHz TCXO. Since each radio channel operating frequency is synthesized and referenced to the 20 MHz TCXO, only one channel will be reported for frequency stability as all channels will have the same frequency characteristics. The emissions 1 MHz above and below the channel band were recorded

to show compliance to the emission limit of 47CFR27.53(1)(3). The emission power 1 MHz above and below the channel edge was measured by utilizing the adjacent channel power function in the spectrum analyzer. The transmitted signal was recorded for frequency changes due to temperature variation and input voltage.

Test Set-Up:

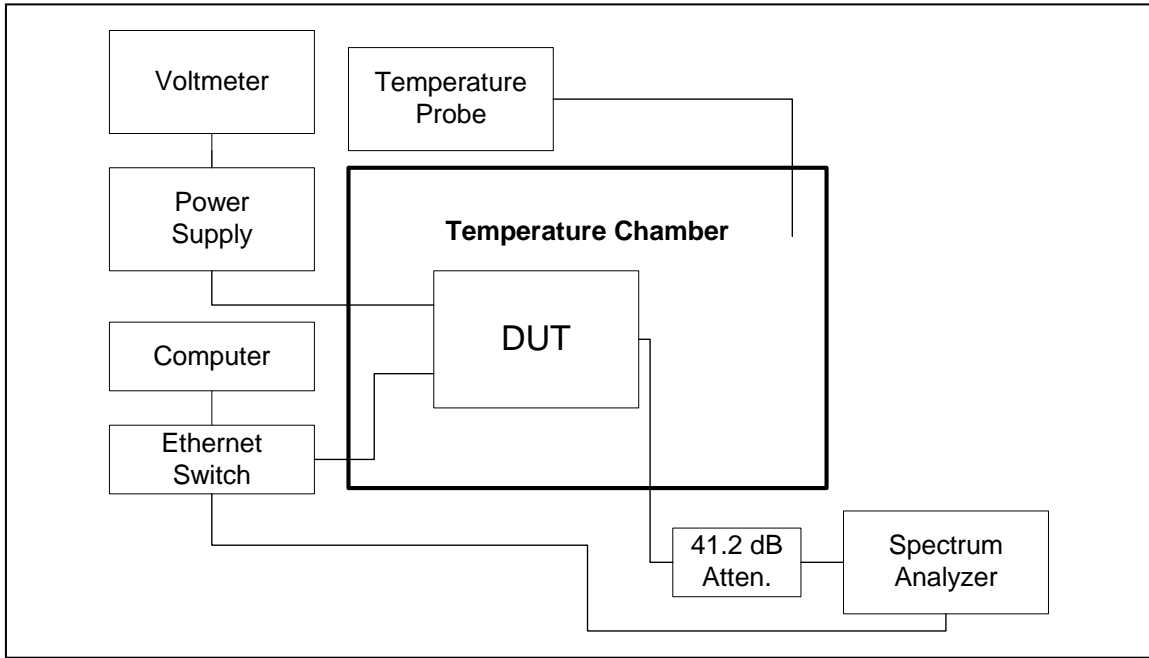

Frequency Stability Test Setup

Frequency Stability Temperature Variation Test Results

Test Conditions: Frequency = 2575 MHz (6.0 MHz BW)
 Supply Voltage: 19.5 VDC Nominal
 Temperature: -30° C to +50° C in 10° C increments

Adjacent Channel Power Method (2575 MHz/6 MHz BW)							
Temp ° C	Lower Adjacent 1 MHz Bin Power (dBm)	Upper Adjacent 1 MHz Bin Power (dBm)	Spec (dBm/MHz)	Lower Margin (dB)	Upper Margin (dB)	Result: Lower Adjacent 1 MHz Bin	Result: Upper Adjacent 1 MHz Bin
-30	-20.82	-20.58	-13	-7.82	-7.58	Complies	Complies
-20	-20.72	-20.31	-13	-7.72	-7.31	Complies	Complies
-10	-22.64	-22.15	-13	-9.64	-9.15	Complies	Complies
0	-21.39	-21.62	-13	-8.39	-8.62	Complies	Complies
10	-20.9	-21.29	-13	-7.9	-8.29	Complies	Complies
20	-21.19	-21.25	-13	-8.19	-8.25	Complies	Complies
30	-20.76	-20.78	-13	-7.76	-7.78	Complies	Complies
40	-22.13	-21.91	-13	-9.13	-8.91	Complies	Complies
50	-21.75	-21.72	-13	-8.75	-8.72	Complies	Complies

Test Results: Pass Frequency Stability - Temperature Variation

Temperature Variation Spectrum Analyzer Plots

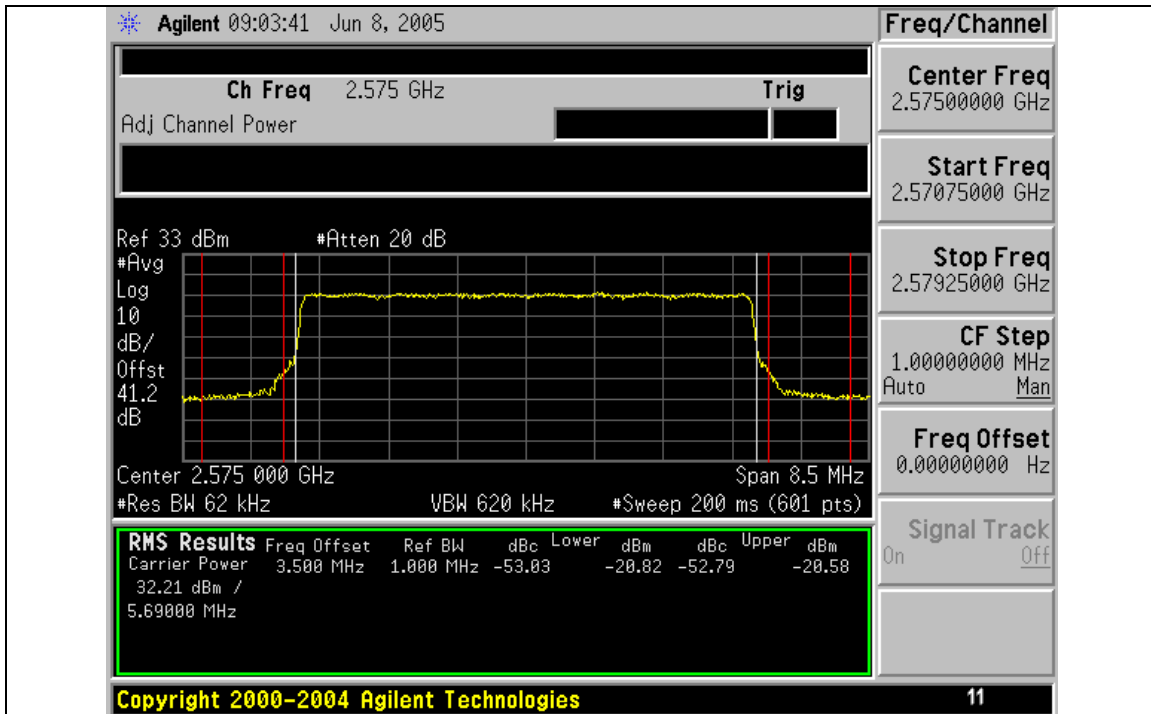

-30° C

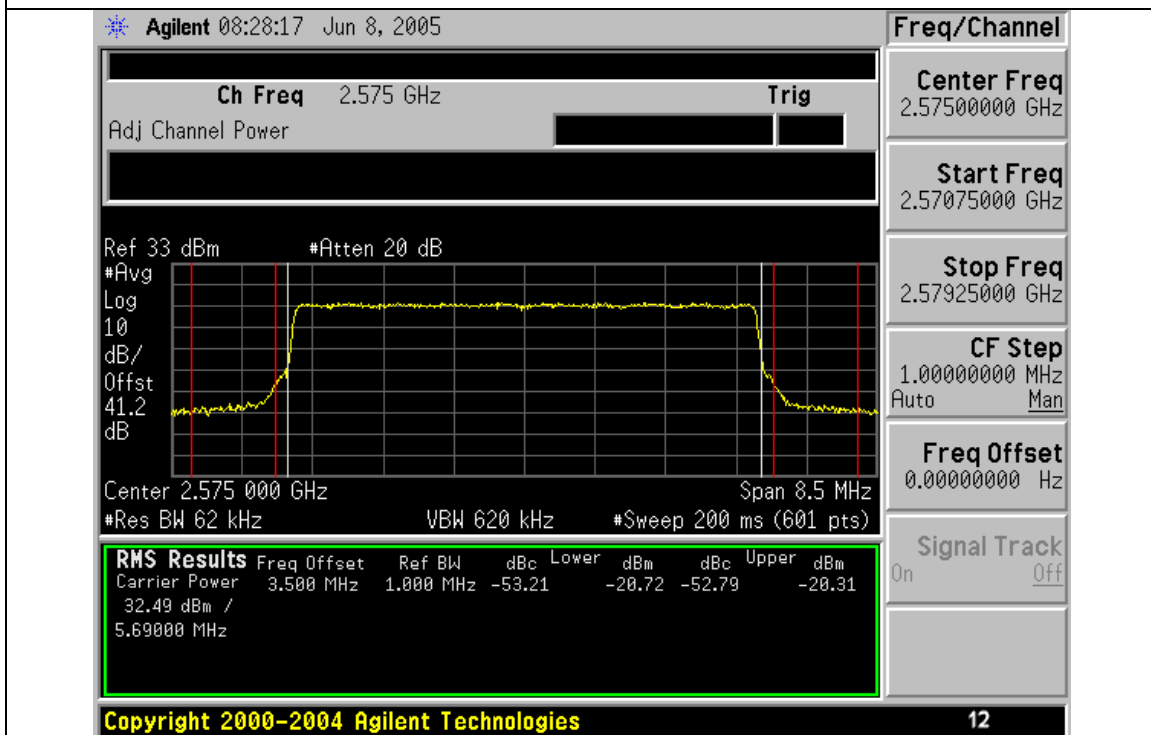

-20° C

Temperature Variation (Cont'd)

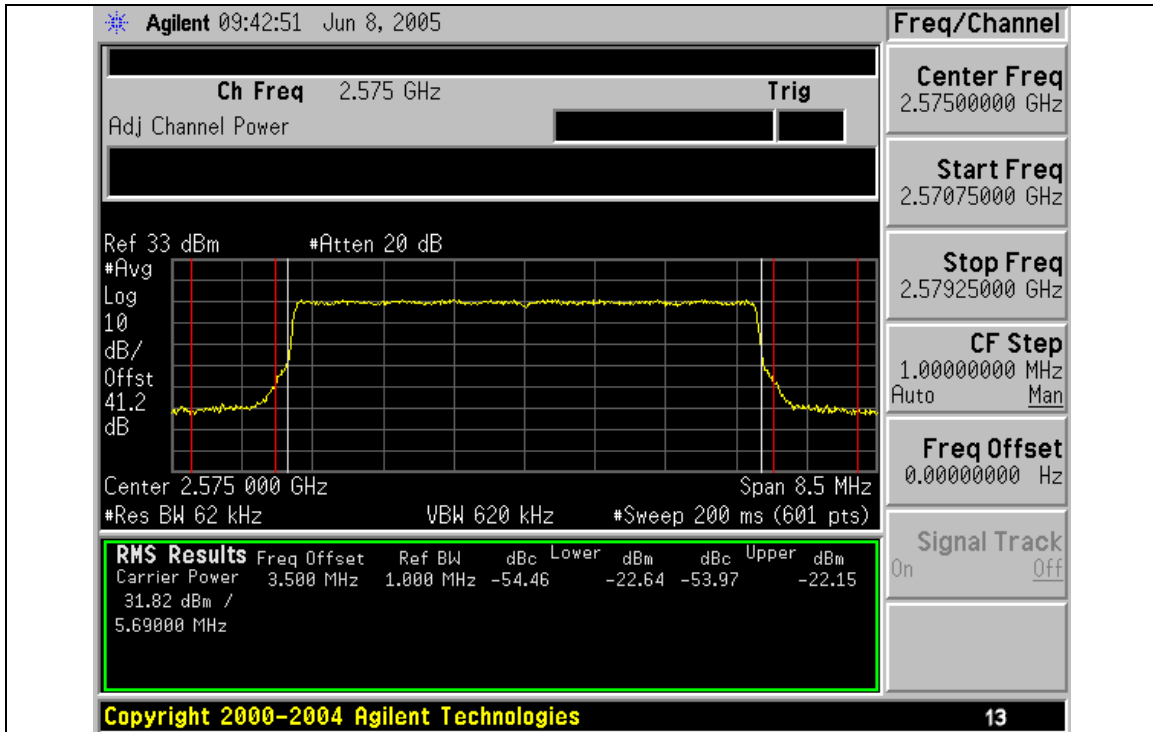

-10° C

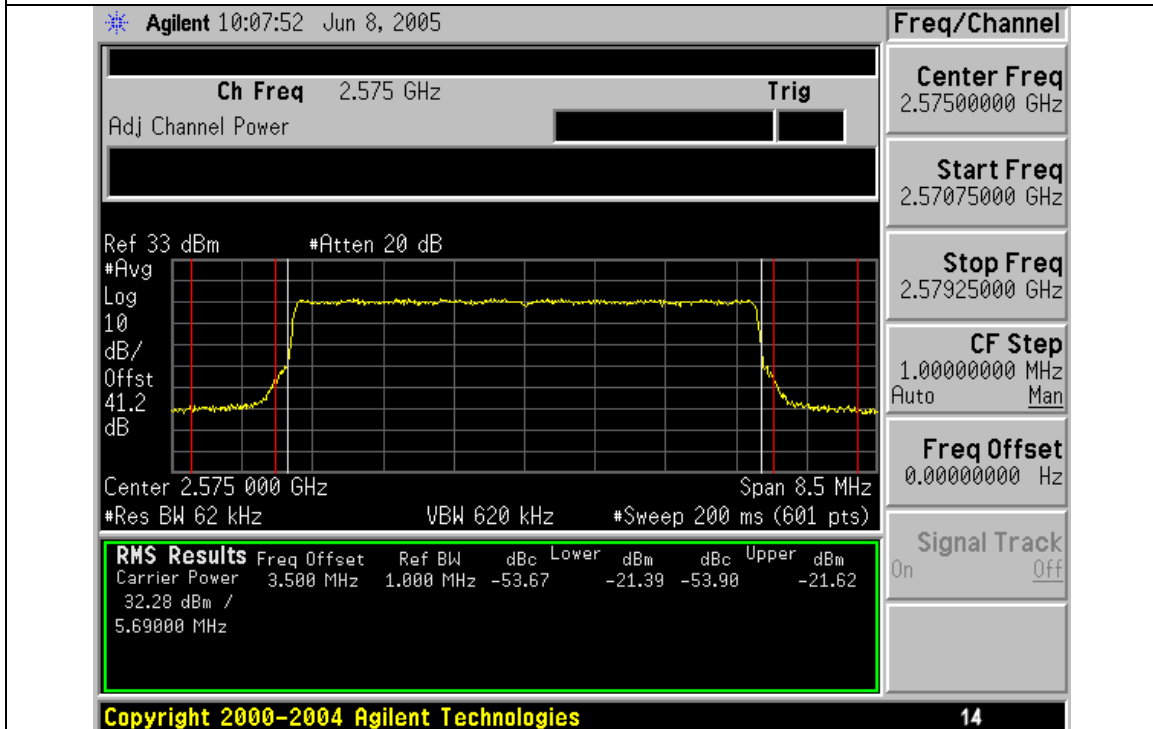

0° C

Temperature Variation (Cont'd)

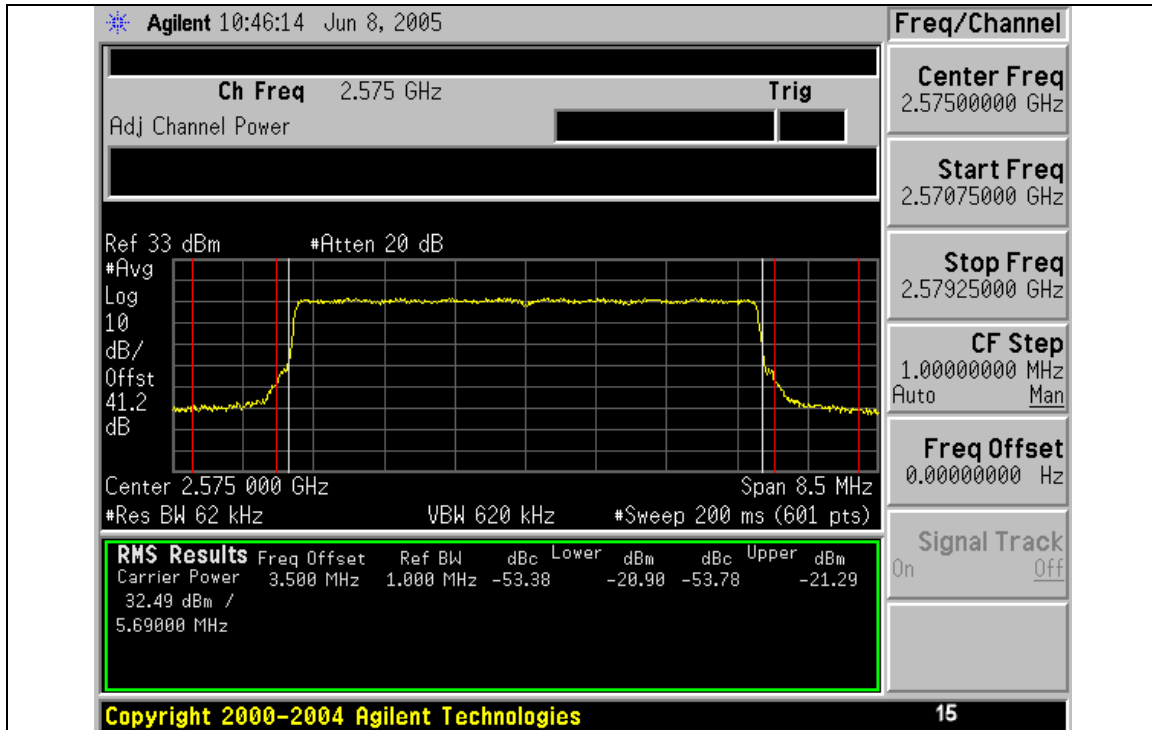

+10° C

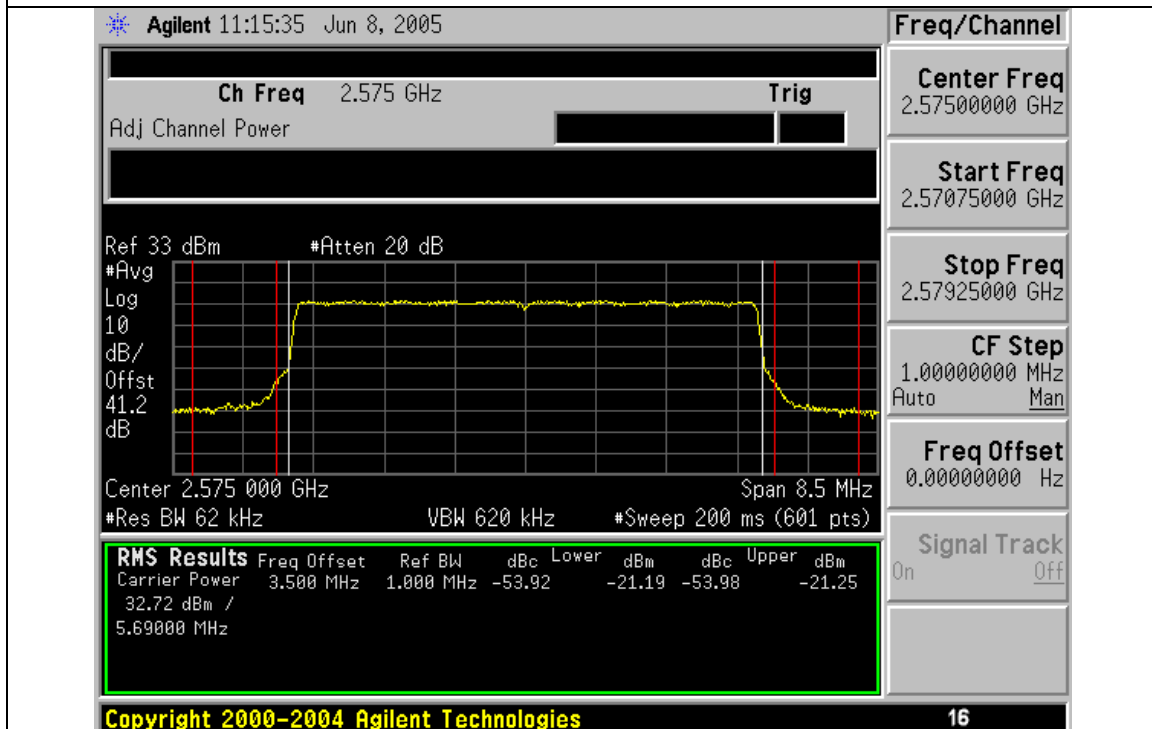

+20° C

Temperature Variation (Cont'd)

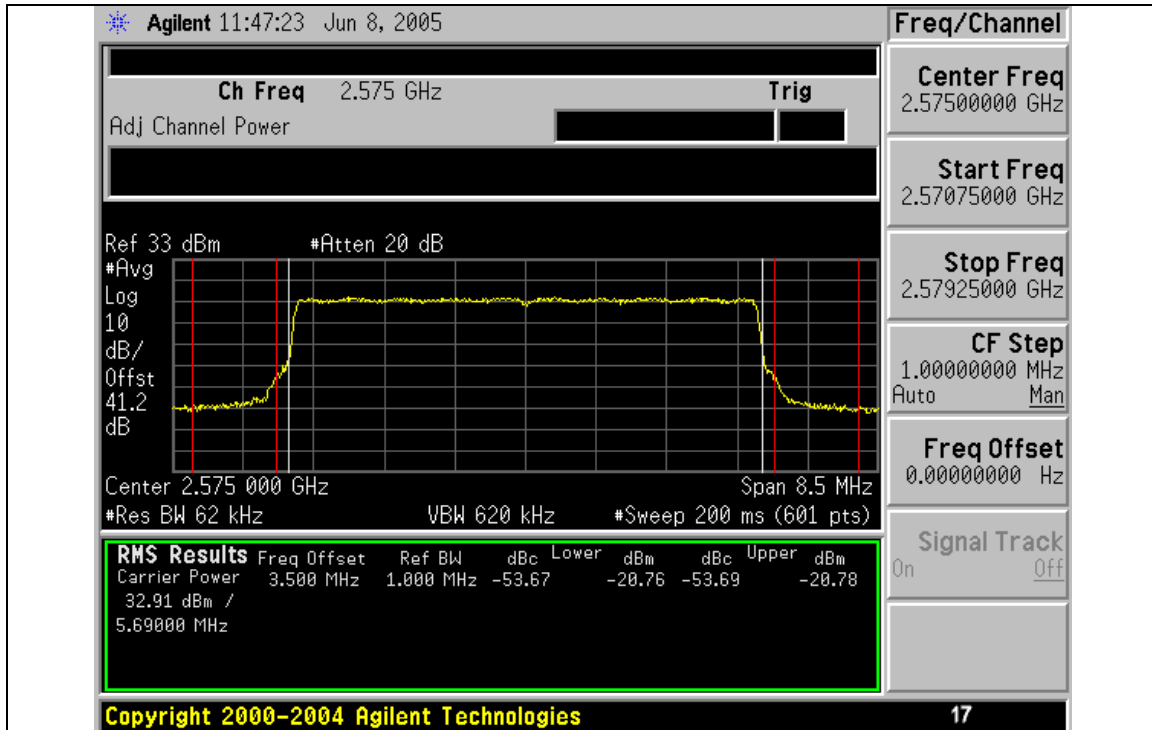

+30° C

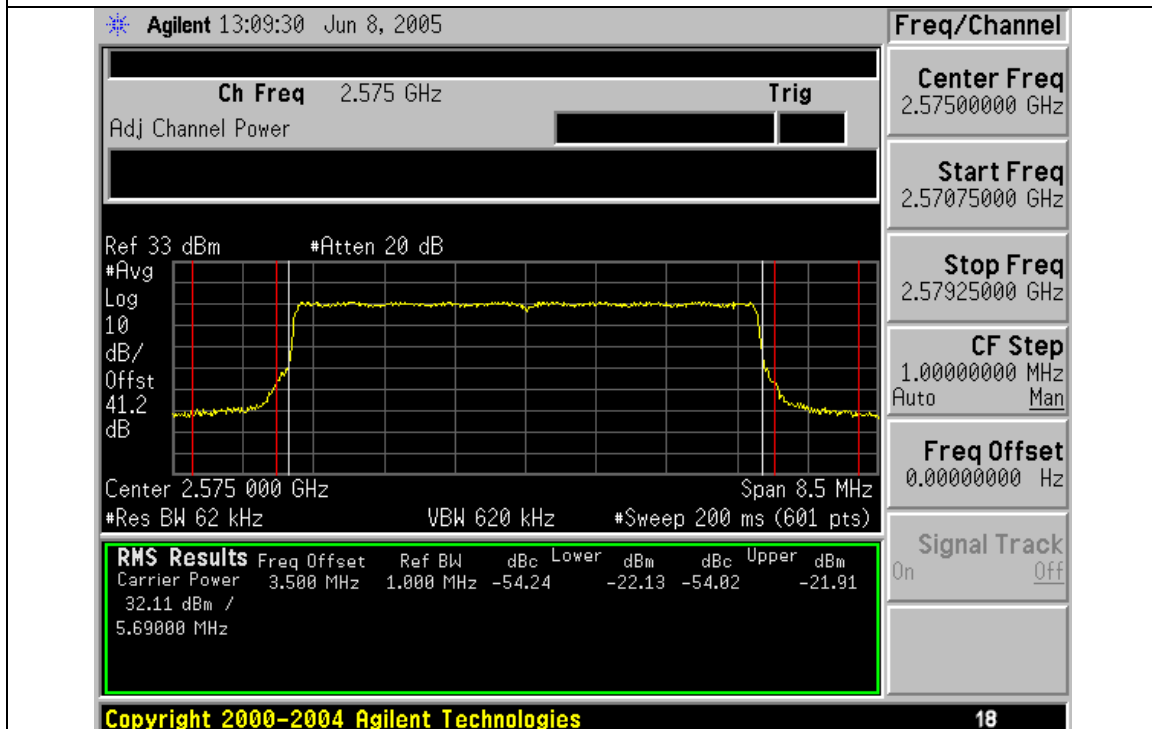

+40° C

Temperature Variation (Cont'd)

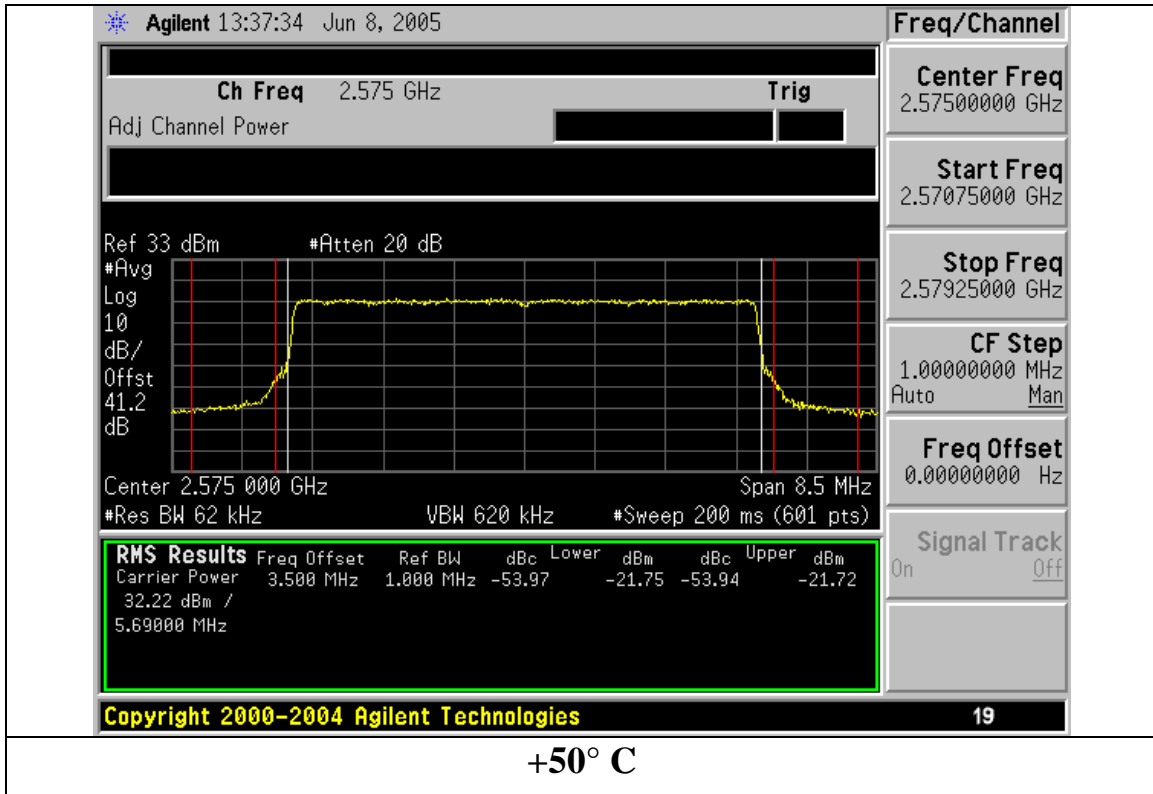

Frequency Stability Supply Voltage Variation Test Results

Test Conditions: Frequency = 2575 MHz, 6.0 MHz BW
Temperature = 20 °C

Source Input Voltage Specification: 19.5 VDC nominal
Test Voltage Range = $0.85 * 19.5 = 16.575$ VDC lower limit
 $1.15 * 19.5 = 22.425$ VDC upper limit

Adjacent Channel Power Method 20° C (2575 MHz/6.0 MHz BW)							
Source Voltage (Vdc)	Lower Adjacent 1 MHz Bin Power (dBm)	Upper Adjacent 1 MHz Bin Power (dBm)	Spec (dBm/MHz)	Lower Margin (dB)	Upper Margin (dB)	Result: Lower Adjacent 1 MHz Bin	Result: Upper Adjacent 1 MHz Bin
16.575	-20.97	-21.21	-13	-7.97	-8.21	Complies	Complies
19.5	-20.57	-20.64	-13	-7.57	-7.64	Complies	Complies
22.425	-21.57	-20.64	-13	-8.57	-7.64	Complies	Complies

Test Results: Pass Temperature Stability - Supply Voltage Variation

Frequency Stability Voltage Variation Spectrum Analyzer Plots

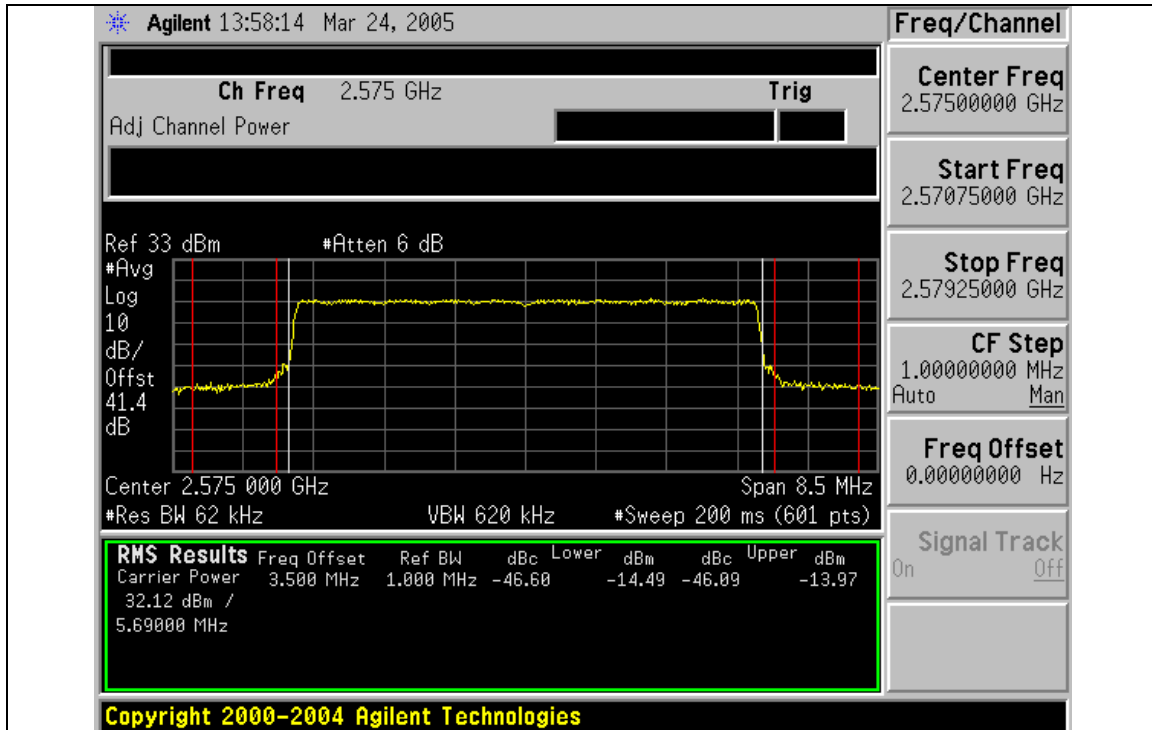

16.58 VDC/20° C

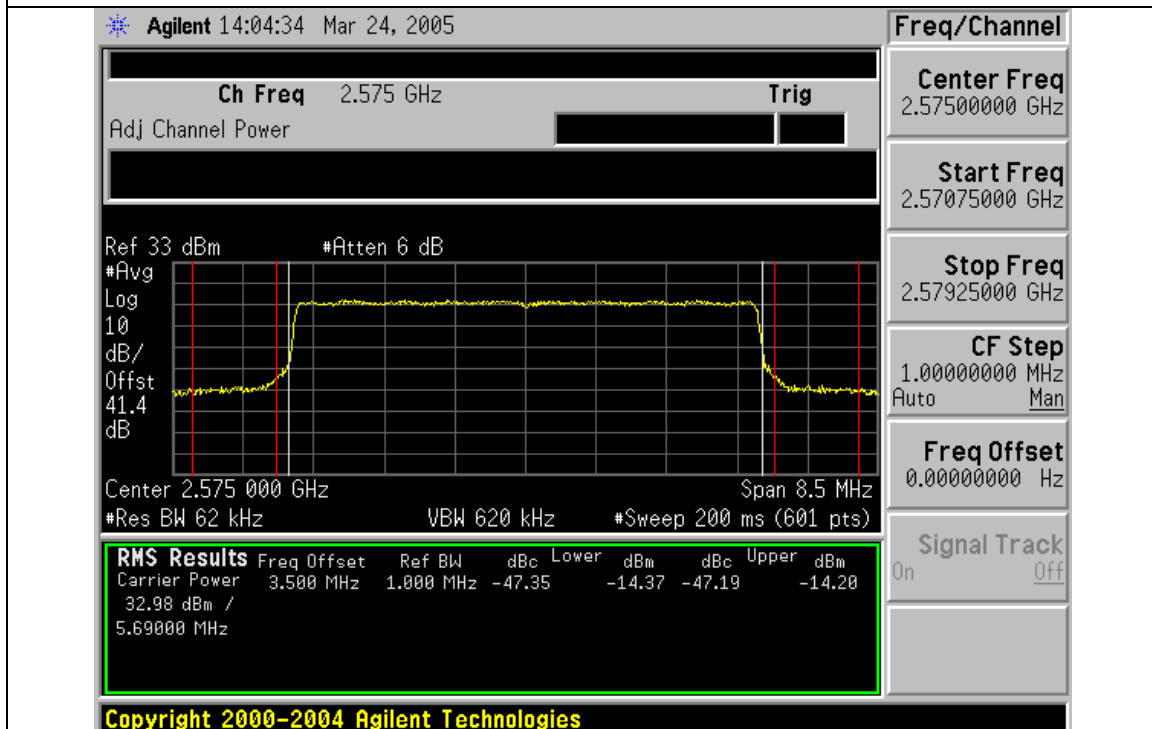

19.5 VDC/20° C

Voltage Variation (Cont'd)

