

Exhibit 6

Text Report

RF Power Output

Rule Part Number: 2.1046, 21.909(g)3, 74.939(g)3
EIRP = 33 dBW+10log(X/6) dBW
X = 6 for this filing
EIRP maximum = 33 dBiW = 1,995 W EIRP

Test Procedure: The RF output power is measured with a power meter. The RF output is applied to a 30 dB attenuator that is connected to the power sensor of the power meter. The transmitter is enabled in test mode with the attached computer.

Test Conditions: Frequency = 2503, 2593, 2683 MHz
Temperature = 25°C
Supply Voltage = 120 Vac / 60 Hz

Test Equipment:

DVM	Fluke 87 III Calibration not required
Spectrum Analyzer	Rohde&Schwarz Model: FSEA 20 S/N: DE14580 Cal Date: 01-04-2002 Cal Due: 01-04-2003
Directional Coupler	Dual Directional Coupler Model: HP 777D S/N: 01271
Attenuator	Pasternack Model: 30dB PE7016-30 Calibration not required
Attenuator	Inmet Model: 64671 6dB Calibration not required
Computer	Dell Inspiron 3500 Model: TS30T FCC ID: LNQUSA-25774-M5E S/N: 9021946BY11687A
Power Supply	GlobTek, Inc. Model: GT-21097-3013 S/N: 0111018712

RF Power Output

Test Set-Up:

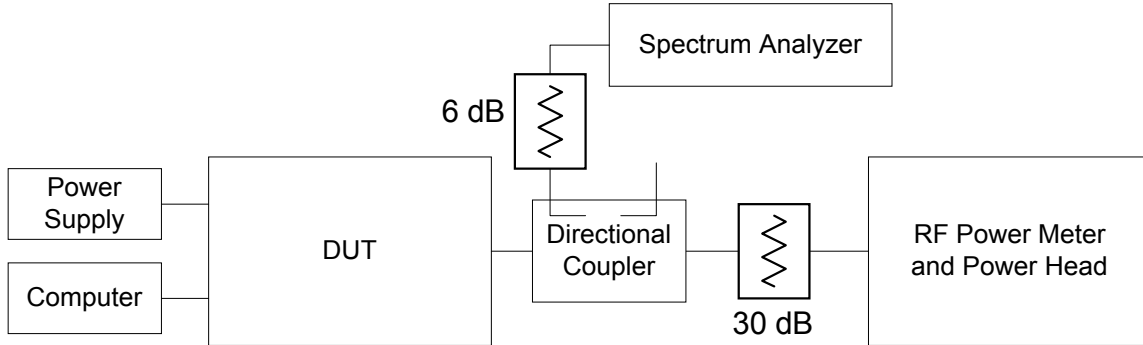

Test Results: 14.29 % transmit duty cycle

Minimum Power setting		
Freq (MHz)	(dBm)	(Watts)
2503	0.58	0.00114
2593	0.60	0.00115
2683	-0.02	0.00100

Maximum Power setting		
Freq (MHz)	(dBm)	(Watts)
2503	32.87	1.94
2593	32.47	1.77
2683	32.20	1.66

RF Power Output

Test Conclusions:

Vertically Polarized Antenna

RF Power Output = 33 dBm

Vertical Antenna Gain = 13 dBi

Transmitted Power = RF Power + Isotropic Antenna Gain

Transmitted Power = 33 + 13 = 46 dBm

Transmitted Power = 16 dBiW < 33 dBiW

Pass: Transmitted Power Output Requirement for Vertically Polarized Antenna

Horizontally Polarized Antenna

RF Power Output = 33 dBm

Horizontal Antenna Gain = 12.2 dBi

Transmitted Power = RF Power + Isotropic Antenna Gain

Transmitted Power = 33 + 12.2 = 45.2 dBm

Transmitted Power = 15.2 dBiW < 33 dBiW

Pass: Transmitted Power Output Requirement for Horizontally Polarized Antenna

Modulation Characteristics

Rule Parts:

2.1047(d), 21.905(b), 21.908(d), 21.908(e), 74.936(a), 74.936(f)

Modulation Characteristics = OFDM

21.905(b) Quadrature amplitude modulation (QAM), digital vestigial sideband modulation (VSB), quadrature phase shift key modulation (QPSK), code division multiple access (CDMA), and orthogonal frequency division multiplex (OFDM) emissions may be employed, subject to compliance with the policies set forth in the Declaratory Ruling and Order, 11 FCC Rcd 18839 (1996). Use of OFDM also is subject to the subsequent Declaratory Ruling and Order, DA 99-554 (Mass Med. Bur. rel. Mar. 19, 1999).

21.908(d) The maximum out-of-band power of an MDS response station using all or part of a 6 MHz channel, employing digital modulation and transmitting with an EIRP greater than -6 dBW per 6 MHz channel shall be attenuated (as measured in accordance with paragraph (e) of this section) at the 6 MHz channel edges at least 25 dB relative to the average 6 MHz channel power level, then attenuated along a linear slope to at least 40 dB at 250 kHz beyond the nearest channel edge, then attenuated along a linear slope from that level to at least 60 dB at 3 MHz above the upper and below the lower licensed channel edges, and attenuated at least 60 dB at all other frequencies.

21.908(e) In measuring compliance with the out-of-band emissions limitations, the licensee shall employ one of two methods in each instance: (1) absolute power measurement of the average signal power with one instrument, with measurement of the spectral attenuation on a separate instrument; or (2) relative measurement of both the average power and the spectral attenuation on a single instrument. The formula for absolute power measurements is to be used when the average signal power is found using a separate instrument, such as a power meter; the formula gives the amount by which the measured power value is to be attenuated to find the absolute power value to be used on the spectrum analyzer or equivalent instrument at the spectral point of concern. The formula for relative power measurements is to be used when the average signal power is found using the same instrument as used to measure the attenuation at the specified spectral points, and allows different resolution bandwidths to be applied to the two parts of the measurement; the formula gives the required amplitude separation (in dB) between the flat top of the (digital) signal and the point of concern.

Modulation Characteristics

For absolute power measurements:

Attenuation in dB (below channel power) = $A + 10\log(\text{CBW} / \text{RBW})$

For relative power measurements:

Attenuation in dB (below flat top) = $A + 10\log(\text{RBW1} / \text{RBW2})$

Where:

A = Attenuation specified for spectral point (e.g., 25, 35, 40, 60 dB)

CBW = Channel bandwidth (for absolute power measurements)

RBW = Resolution bandwidth (for absolute power measurements)

RBW1 = Resolution bandwidth for flat top measurement (relative)

RBW2 = Resolution bandwidth for spectral point measurement (relative)

74.936(a) An ITFS station may employ amplitude modulation (C3F) for the transmission of the visual signal and frequency modulation (F3E) or (G3E) for the transmission of the aural signal when transmitting a standard analog television signal. Quadrature amplitude modulation (QAM), digital vestigial sideband modulation (VSB), quadrature phase shift key modulation (QPSK), code division multiple access (CDMA) and orthogonal frequency division multiplex (OFDM) emissions may be employed, subject to compliance with the policies set forth in the *Declaratory Ruling and Order*, 11 FCC Rcd 18839 (1996). Use of OFDM also is subject to the subsequently *Digital Declaratory Ruling and Order*, DA 99-554 (Mass Med. Bur. rel. Mar. 19, 1999).

74.936(f) The maximum out-of-band power of an ITFS response station using all or part of a 6 MHz channel, employing digital modulation and transmitting with an EIRP greater than -6 dBW per 6 MHz channel shall be attenuated (as measured in accordance with §21.908(e)) at the 6 MHz channel edges at least 25 dB relative to the average 6 MHz channel power level, then attenuated along a linear slope to at least 40 dB at 250 kHz beyond the nearest channel edge, then attenuated along a linear slope from that level to at least 60 dB at 3 MHz above the upper and below the lower licensed channel edges, and attenuated at least 60 dB at all other frequencies. The maximum out-of-band power of an ITFS response station using all or part of a 6 MHz channel, employing digital modulation and transmitting with an EIRP no greater than -6 dBW per 6 MHz channel shall be attenuated (as measured in accordance with §21.908(e)) at the channel edges at least 25 dB relative to the average 6 MHz channel transmitter output power level (P), then attenuated along a linear slope to at least 40 dB or $33+10\log(P)$ dB, whichever is the lesser attenuation, at 250 kHz beyond the nearest channel edge, then attenuated along a linear slope from that level to at least 60 dB or $43+10\log(P)$ dB, whichever is the lesser attenuation, at 3 MHz above the upper and below the lower licensed channel edges, and attenuated at least 60 dB or $43+10\log(P)$ dB, whichever is the lesser attenuation, at all other frequencies.

Modulation Characteristics

Test Procedure:

The Orthogonal Frequency Division Multiplexing (OFDM) modulated Time Division Duplex (TDD) RF signal from the test unit is applied to a spectrum analyzer. The Spectrum Analyzer is time gated, with zero delay, to capture the transmission during the burst. An RMS detector is used to measure the average power of the transmission. The resolution bandwidth of the flat top measurement is equal to the resolution bandwidth of the spectral point measurement thereby setting the $10\log(RBW1 / RBW2) = 0$ for the relative power measurement method. The transmitter is enabled in test mode with the attached computer.

Test Conditions:

Frequencies = 2503, 2593, 2683 MHz

Temperature = 25°C

Supply Voltage = 120 Vac / 60 Hz

Modulation Characteristics

Test Set-Up:

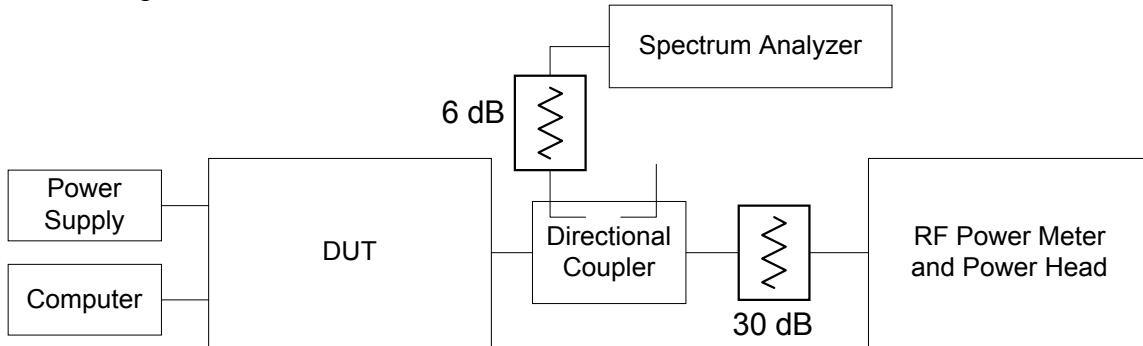

Test Equipment:

DVM	Fluke 87 III Calibration not required
Spectrum Analyzer	Rohde&Schwarz Model: FSEA 20 S/N: DE14580 Cal Date: 01-04-2002 Cal Due: 01-04-2003
Directional Coupler	Dual Directional Coupler Model: HP 777D S/N: 01271
Attenuator	Pasternack Model: 30dB PE7016-30 Calibration not required
Attenuator	Inmet Model: 64671 6dB Calibration not required
Computer	Dell Inspiron 3500 Model: TS30T FCC ID: LNQUSA-25774-M5E S/N: 9021946BY11687A
Power Supply	GlobTek, Inc. Model: GT-21097-3013 S/N: 0111018712

Modulation Characteristics

Test Results: Channel 1, 2503 MHz (33dBm / 2W)

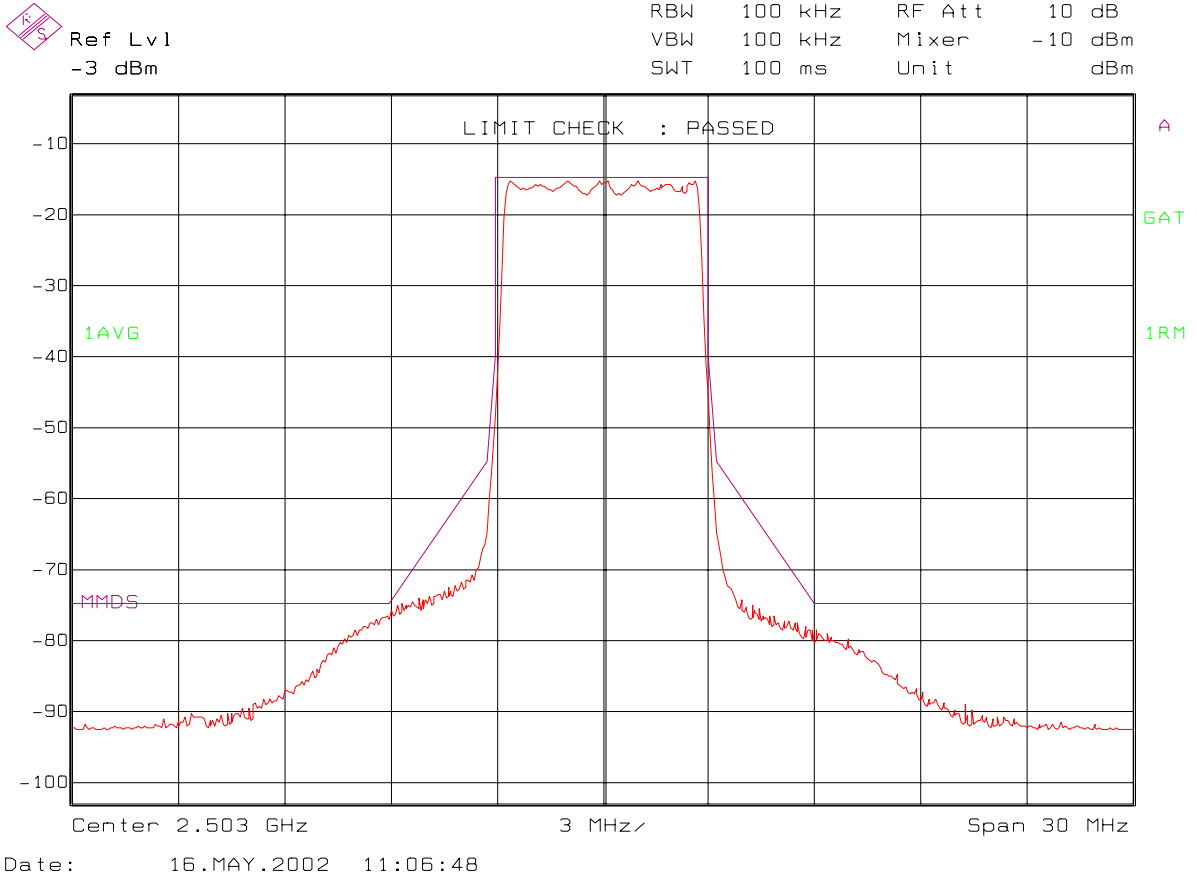

Modulation Characteristics

Test Results: Channel 16, 2593 MHz (33dBm / 2W)

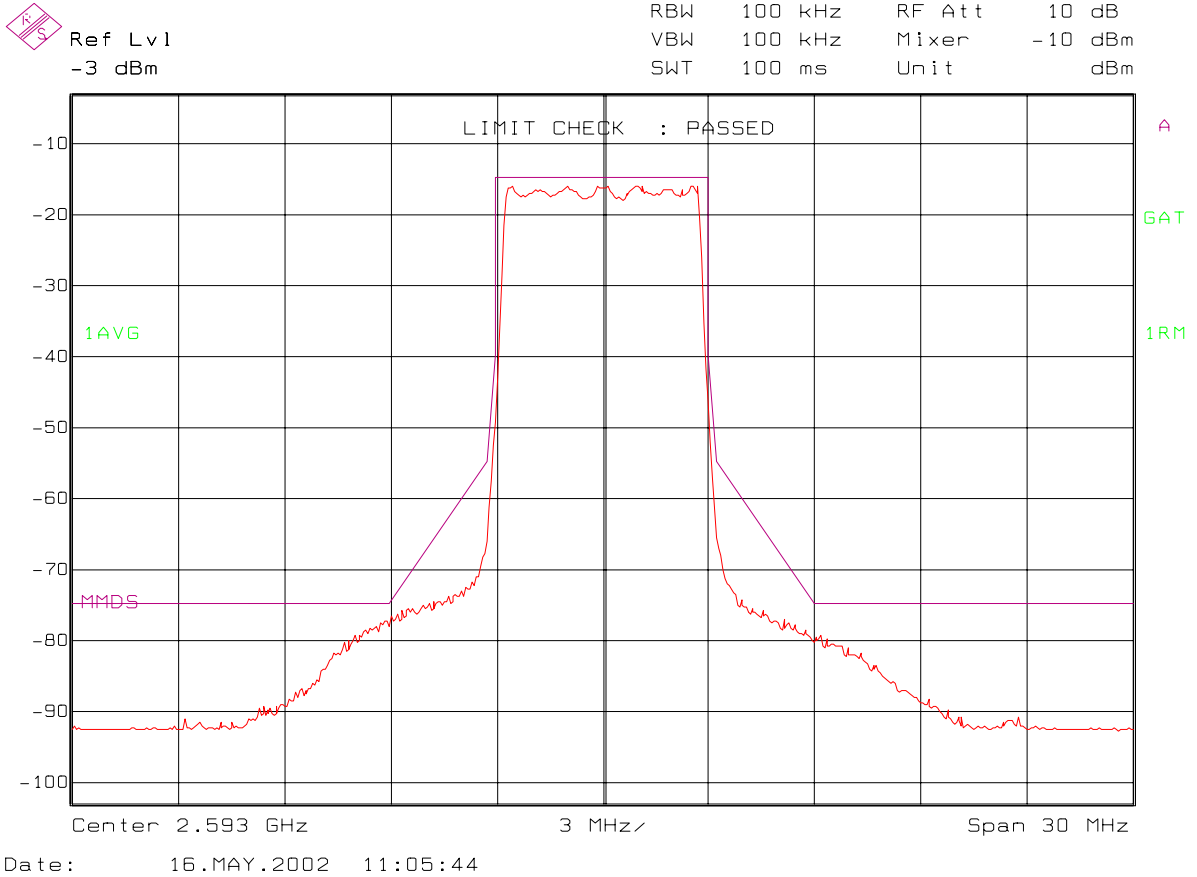

Modulation Characteristics

Test Results: Channel 31, 2683 MHz (33dBm / 2W)

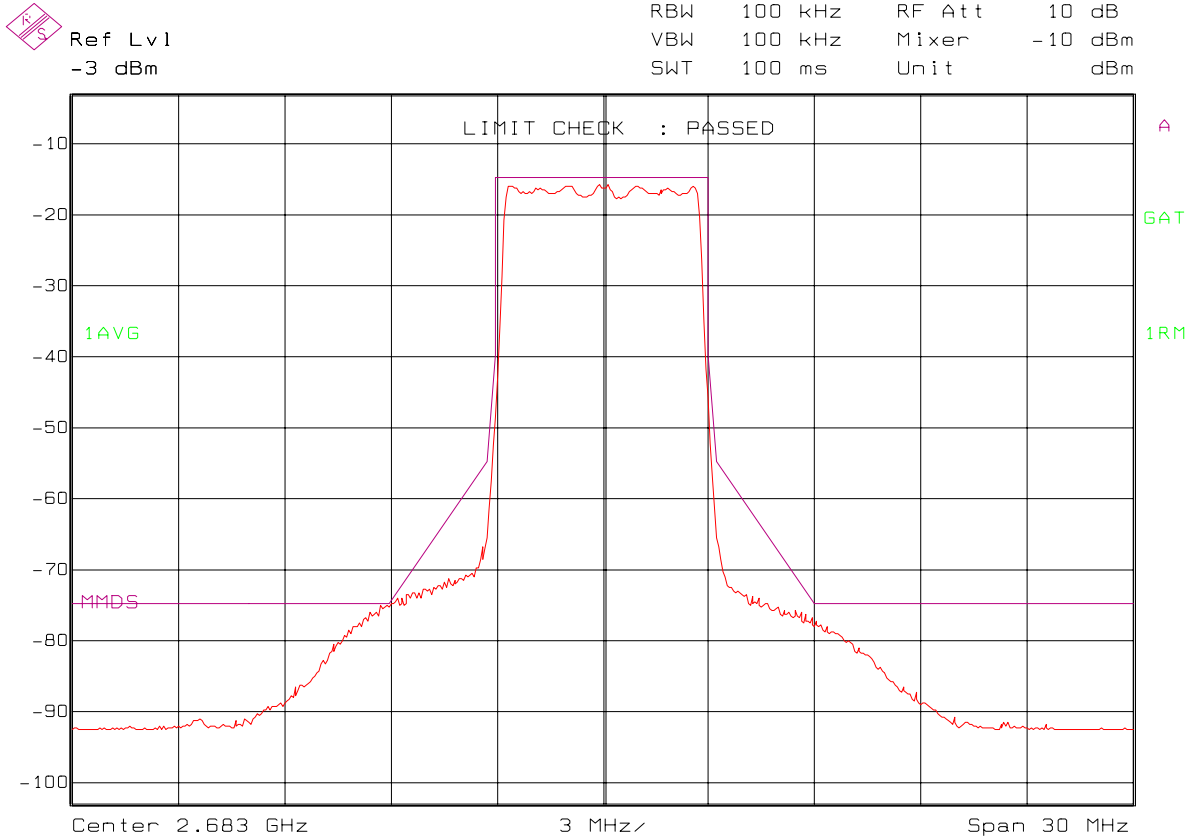

Date: 16.MAY.2002 11:04:15

Occupied Bandwidth

Rule Part Number: 2.1049(h), 21.105

Each authorization issued pursuant to these rules will show, as the emission designator, a symbol representing the class of emission which shall be prefixed by a number specifying the necessary bandwidth. This figure does not necessarily indicate the bandwidth actually occupied by the emission at any instant. In those cases where part 2 of this chapter does not provide a formula for the computation of the necessary bandwidth, the occupied bandwidth may be used in the emission designator.

Test Procedure: The Orthogonal Frequency Division Multiplexing (OFDM) modulated Time Division Duplex (TDD) RF signal from the test unit is applied to a spectrum analyzer. The Spectrum Analyzer is time gated, with zero delay, to capture the transmission during the burst. The occupied bandwidth of the test unit is recorded by measuring the modulation bandwidth at the 25 dB points. The transmitter is enabled in test mode with the attached computer.

Test Conditions: Frequency = 2503, 2593, 2683 MHz
Temperature = 25°C
Supply Voltage = 120 Vac / 60 Hz

Test Results Summary:

Channel 1

Occupied Bandwidth = 2.50584820 GHz – 2.50016683 GHz
Occupied Bandwidth = 5.68137 MHz

Channel 16

Occupied Bandwidth = 2.59586323 GHz – 2.59015180 GHz
Occupied Bandwidth = 5.71143 MHz

Channel 31

Occupied Bandwidth = 2.68586323 GHz – 2.68016683 GHz
Occupied Bandwidth = 5.6964 MHz

Occupied Bandwidth

Test Set-Up:

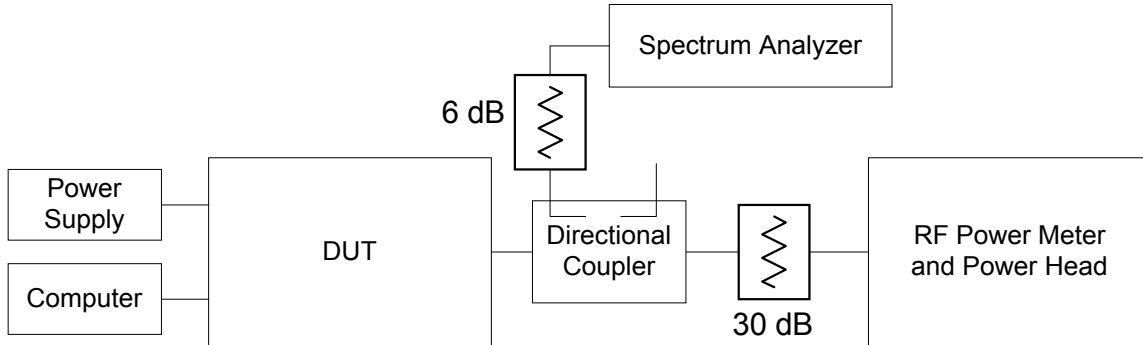

Test Equipment:

DVM	Fluke 87 III Calibration not required
Spectrum Analyzer	Rohde&Schwarz Model: FSEA 20 S/N: DE14580 Cal Date: 01-04-2002 Cal Due: 01-04-2003
Directional Coupler	Dual Directional Coupler Model: HP 777D S/N: 01271
Attenuator	Pasternack Model: 30dB PE7016-30 Calibration not required
Attenuator	Inmet Model: 64671 6dB Calibration not required
Computer	Dell Inspiron 3500 Model: TS30T FCC ID: LNQUSA-25774-M5E S/N: 9021946BY11687A
Power Supply	GlobTek, Inc. Model: GT-21097-3013 S/N: 0111018712

Occupied Bandwidth

Test Results: Channel 1

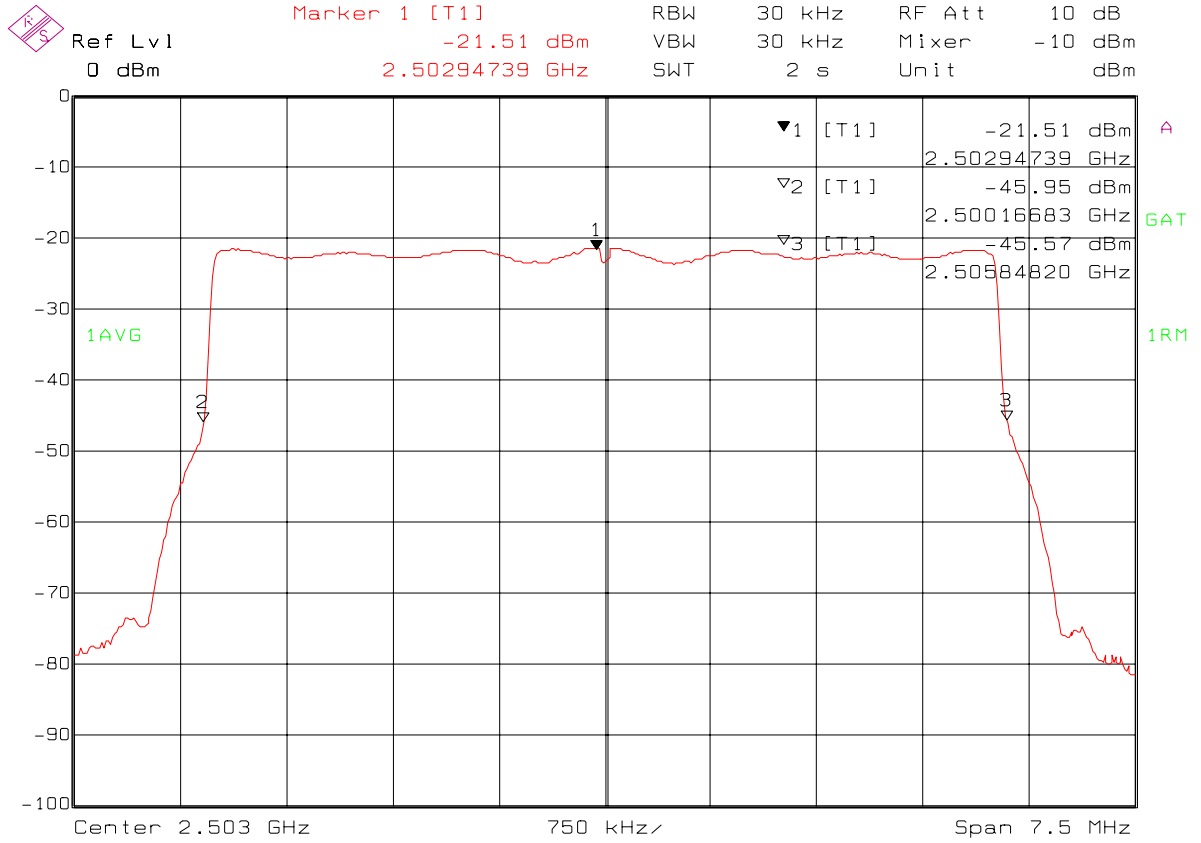

Date: 16.MAY.2002 11:10:34

Occupied Bandwidth

Test Results: Channel 16

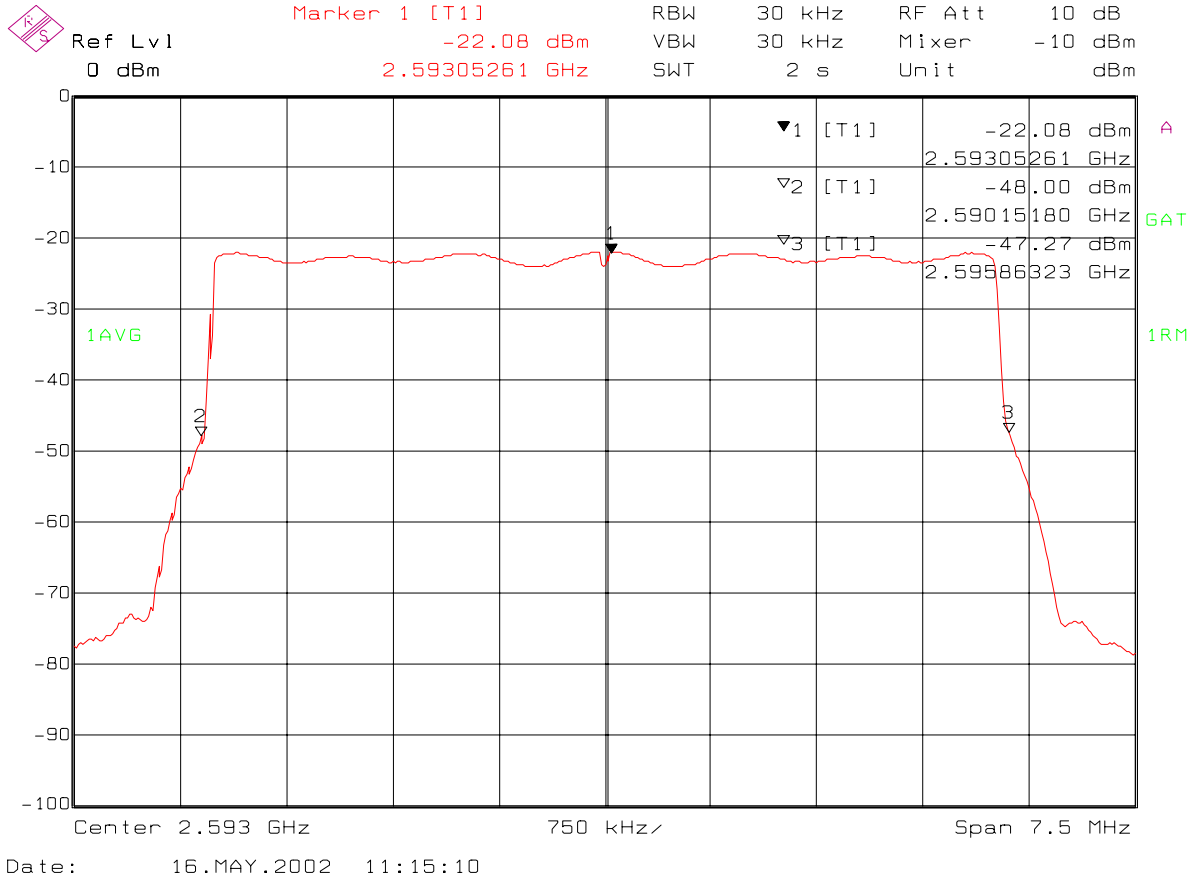

Occupied Bandwidth

Test Results: Channel 31

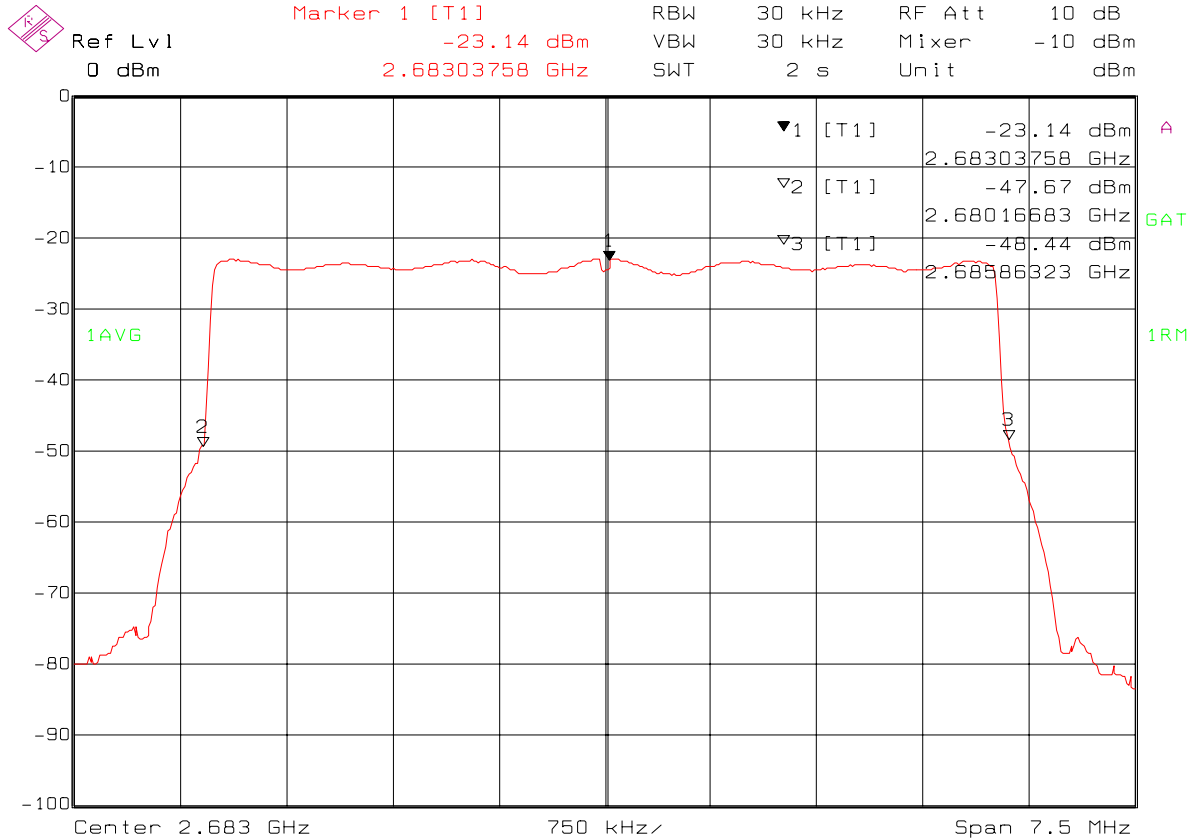

Date: 16.MAY.2002 11:16:35

Spurious emissions at antenna terminals

Rule Part Number: 2.1051, 2.1049, 2.1057

Frequency Range = 9 kHz to 26.86 GHz

Attenuation (dB) below the power (W) supplied to the antenna transmission line

Attenuation = $43 + 10 \log P$, or 70 dBc, whichever is less stringent

Attenuation = $43 + 10 \log(2) = 46$ dBc 2 watt transmit level

Test Procedure: The Orthogonal Frequency Division Multiplexing (OFDM) modulated Time Division Duplex (TDD) RF signal from the test unit is applied to a spectrum analyzer thru a 20 dB attenuator. The transmission is recorded from 9 kHz to 26.5 GHz. The transmitter is enabled in test mode with the attached computer.

Test Conditions: Frequency = 2593 MHz
Temperature = 25°C
Supply Voltage = 120 Vac / 60 Hz

Spurious emissions at antenna terminals

Test Equipment: CPE

DVM	Fluke 87 III Calibration not required
Attenuator	Inmet Corporation Model: 12B-20dB Calibration not required
Spectrum Analyzer	Hewlett Packard HP8563E S/N: 3221A00143 Cal Date: 2-12-2002 Cal Due: 2-12-2003
Computer	Dell Inspiron 3500 Model: TS30T FCC ID: LNQUSA-25774-M5E S/N: 9021946BY11687A
Power Supply	GlobTek, Inc. Model: GT-21097-3013 S/N: 0111018712

Test Setup

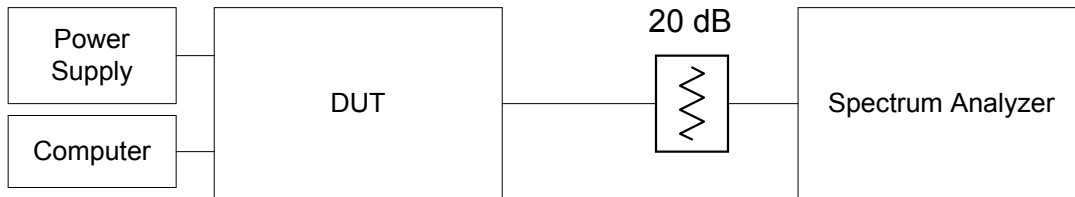

Spurious emissions at antenna terminals

Test Results: The spectral measurement from 9 kHz to 150 kHz resulted in one observed spurious signal that is internal to the spectrum analyzer.

Channel 16, 2593 MHz (33 dBm / 2 Watts)
9 KHz – 150 KHz

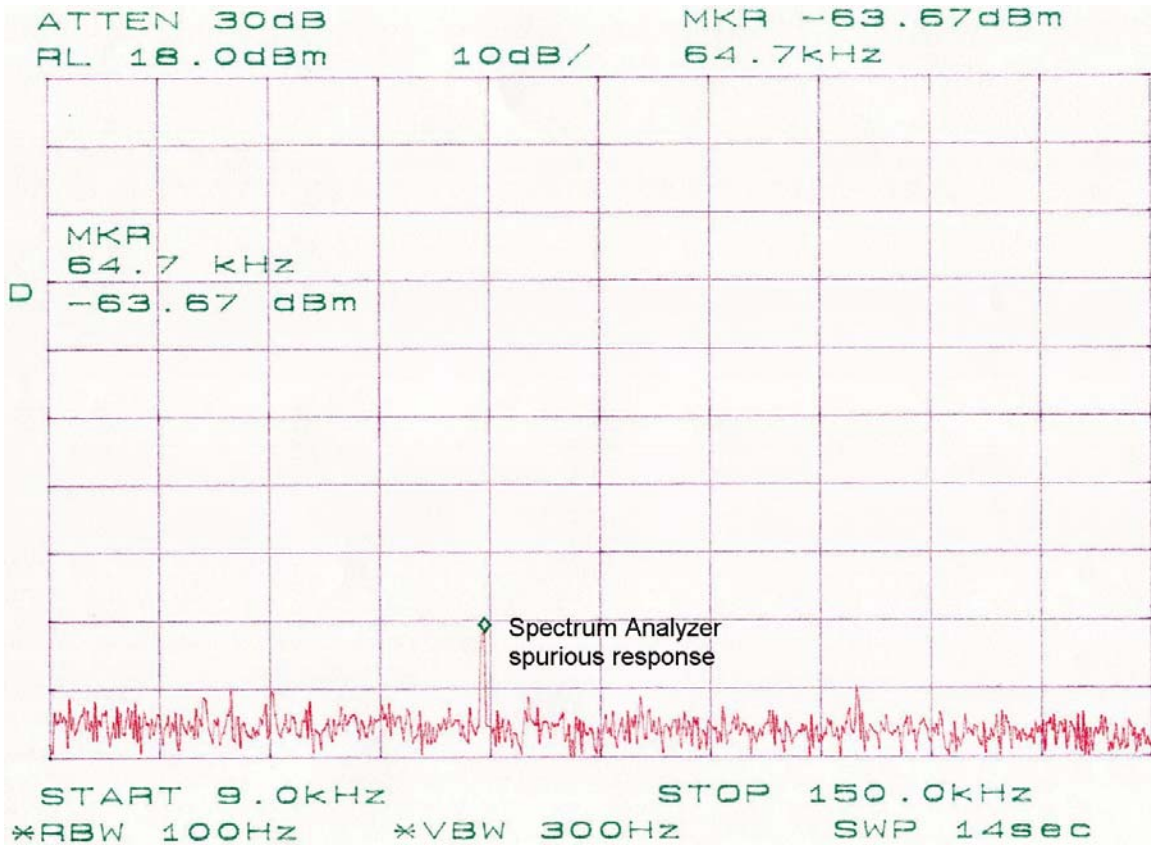

Spurious emissions at antenna terminals

Test Results: The spectral measurement from 150 kHz to 30 MHz resulted in no observed spurious signals.

Channel 16, 2593 MHz (33 dBm / 2 Watts)
150 KHz – 30 MHz

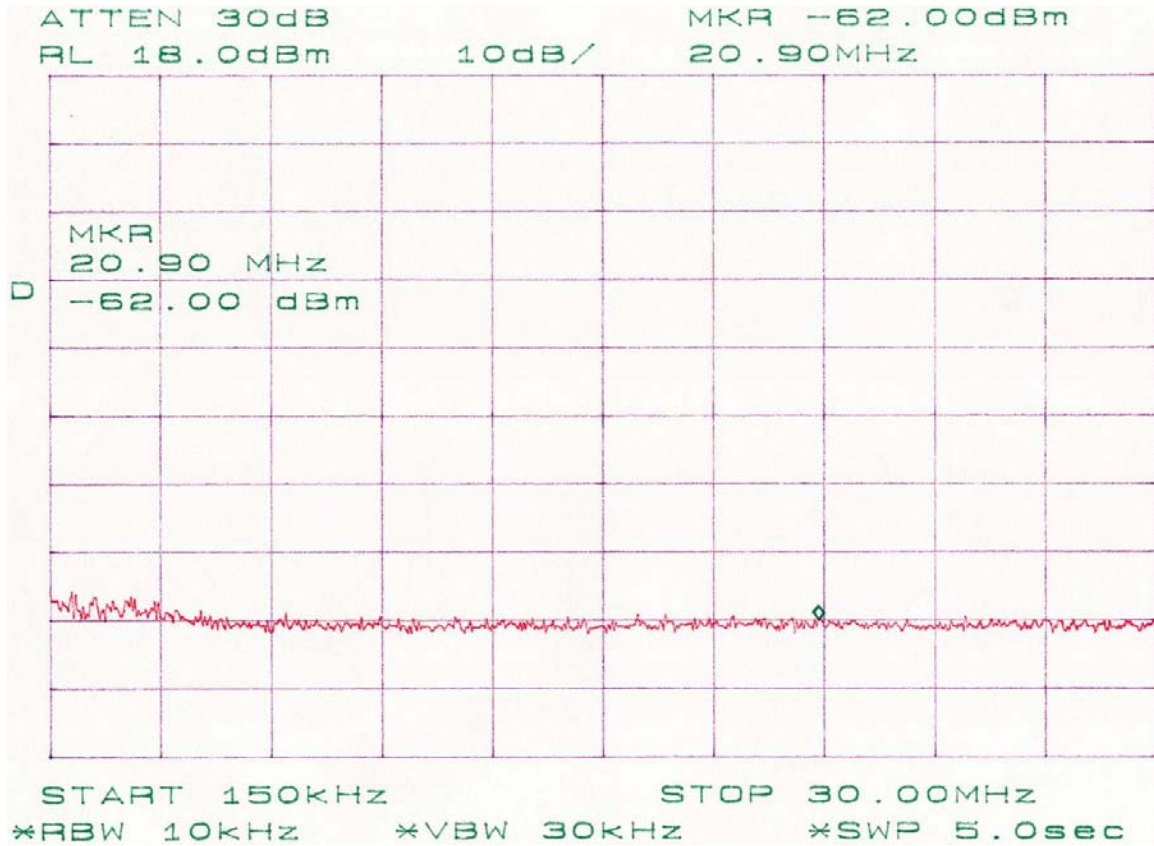

Spurious emissions at antenna terminals

Test Results: The spectral measurement from 30 MHz to 1 GHz resulted in no observed spurious signals.

Channel 16, 2593 MHz (33 dBm / 2 Watts)
30 MHz – 1 GHz

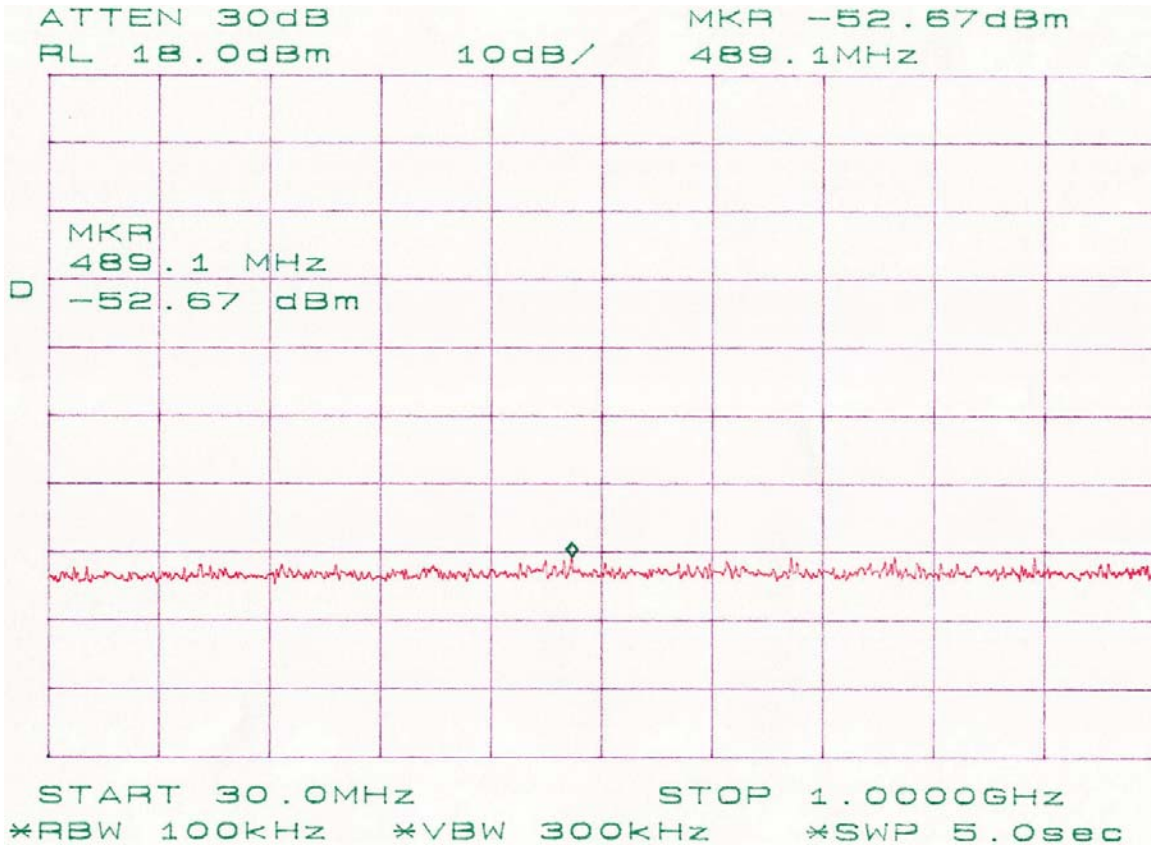

Spurious emissions at antenna terminals

Test Results: The spectral measurement from 1 GHz to 26.5 GHz resulted in no observed spurious signals.

Channel 16, 2593 MHz (33 dBm / 2 Watts)
1 GHz – 26.5 GHz

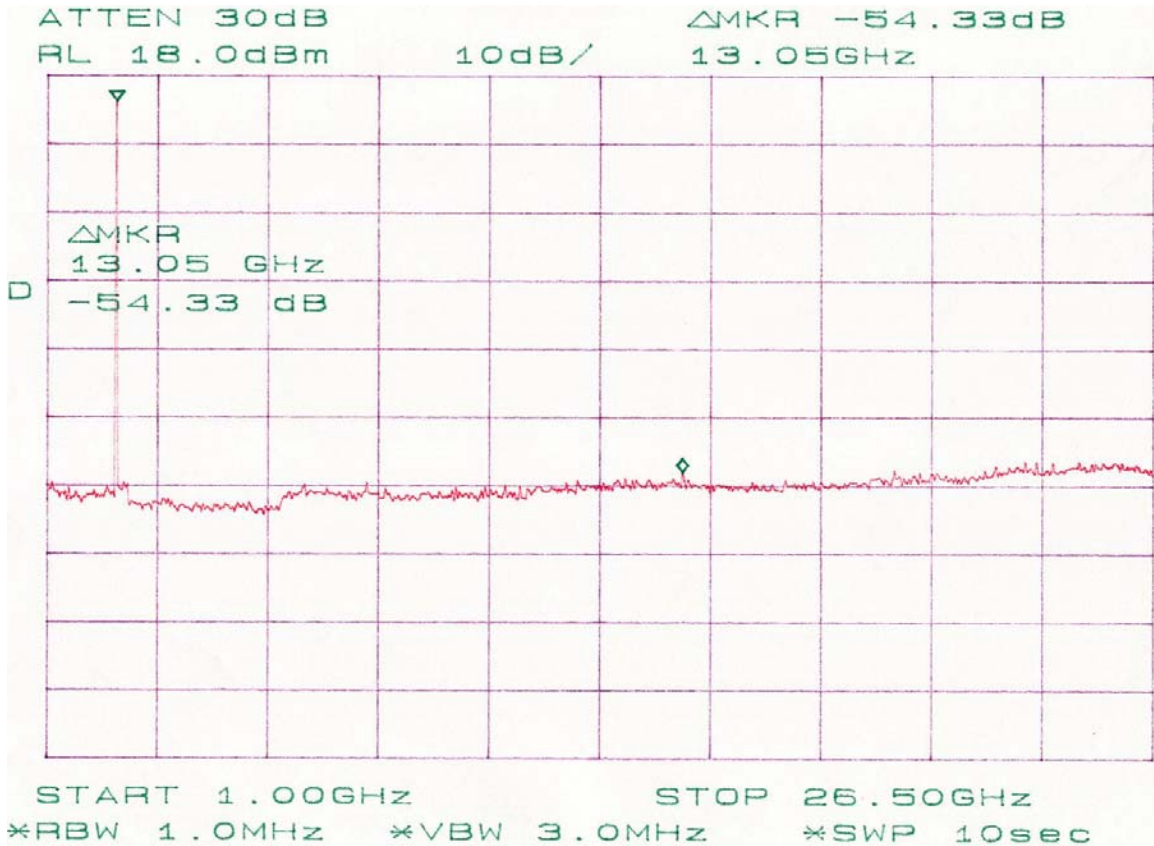

Field strength of spurious radiation

Rule Part Number: 2.1053, 2.1049, 2.1057

Frequency Range = 30 MHz to 26.86 GHz
Case Radiation Attenuation = $43+10\log P = -13$ dBm maximum

Test Procedure: The field strength of spurious radiation was measured at an open area test site with applicable measurement antennas, low noise amplifiers, and spectrum analyzers. Measurements were performed by TUV Product Service Inc – Taylors Falls on May 20, 2002. Spurious signals were maximized for peak level by rotation of the test unit and elevation of the measurement antenna. Antenna substitution was performed to verify compliance with the regulations. Identified spurious signals between 30 MHz and 1000 MHz are measured with a 120 kHz/6 dB bandwidth and quasi-peak detection. Spurious signals above 1000 MHz are measured with a 1 MHz/6 dB bandwidth and peak detection.

Test Conditions: Channel 16
Frequency = 2593 MHz
Temperature = 25°C
Supply Voltage = 120 Vac / 60 Hz

Field strength of spurious radiation

Test Equipment: NextNet Wireless, Inc.

Computer	Dell Inspiron 3500 Model: TS30T FCC ID: LNQUSA-25774-M5E S/N: 9021946BY11687A
Power Supply	GlobTek, Inc. Model: GT-21097-3013 S/N: 0111018712

Field strength of spurious radiation

Test Equipment: TUV Product Services



Emissions Test Conditions: RADIATED EMISSIONS (Electric Field)

The *RADIATED EMISSIONS (ELECTRIC FIELD)* measurements, in the frequency range of 30 MHz-1000 MHz, were tested in a horizontal and vertical polarization at the following test location :

- Test not applicable

- Wild River Lab Large Test Site (Open Area Test Site) – NSA measurements made 7-01, due 7-02
- Wild River Lab Small Test Site (Open Area Test Site)
- Oakwood Lab (Open Area Test Site)

at a test distance of :

- 3 meters
- 10 meters
- 30 meters

Test equipment used :

TUV ID	Model Number	Manufacturer	Description	Serial Number	Cal Due
■ - 2665	ZHL-1042J	Mini-Circuits	Preamplifier	32296	09-12-02
■ - 2690	8566B	Hewlett-Packard	Spectrum Analyzer (Unit F)	2430A00930	11-19-02
■ - 2678	85662A	Hewlett-Packard	Analyzer Display (Unit F)	2403A08134	11-19-02
■ - 2684	85650A	Hewlett-Packard	Quasi-Peak Adapter (Unit F)	2521A01006	11-19-02
■ - 3204	EM-6917B	Electro-Metrics	Biconicalog Periodic	102	09-24-02

All measurement instrumentation is traceable to the National Institute of Standards and Technology (NIST) and is calibrated annually.

Emissions Test Conditions: INTERFERENCE POWER

The *INTERFERENCE POWER* measurements were performed by using the absorbing clamp on the mains and interface cables in the frequency range 30 MHz - 300 MHz at the following test location :

- Test not applicable

- Wild River Lab Large Test Site (Open Area Test Site)
- Wild River Lab Small Test Site (Open Area Test Site)
- Oakwood Lab (Open Area Test Site)
- Wild River Lab Screen Room
- New Brighton Lab Shielded Room

Test equipment used :

Model Number	Manufacturer	Description	Serial Number
--------------	--------------	-------------	---------------

Field strength of spurious radiation

Test Equipment: TUV Product Services



Emissions Test Conditions: RADIATED EMISSIONS (Electric Field)

The EQUIVALENT RADIATED EMISSIONS measurements in the frequency range 1 GHz - 27 GHz were performed in a horizontal and vertical polarization at the following test location :

- Wild River Lab Large Test Site (Open Area Test Site)
- Wild River Lab Small Test Site (Open Area Test Site)
- Oakwood Lab (Open Area Test Site)
- Wild River Lab Screen Room

at a test distance of:

- 1 meters
- 3 meters
- 10 meters

- Test not applicable

Test equipment used :

TUV ID	Model Number	Manufacturer	Description	Serial Number	Cal Due
■ - 2075	3115	Electro-Mechanics (EMCO)	Ridge Guide Ant. 1-18 GHz	9001-3275	10-20-02
■ - 2665	ZHL-1042J	Mini-Circuits	Preamplifier	32296	09-12-02
■ - 2690	8566B	Hewlett-Packard	Spectrum Analyzer (Unit F)	2430A00930	11-19-02
■ - 2678	85662A	Hewlett-Packard	Analyzer Display (Unit F)	2403A08134	11-19-02
■ - 2684	85650A	Hewlett-Packard	Quasi-Peak Adapter (Unit F)	2521A01006	11-19-02
■ - 3204	EM-6917B	Electro-Metrics	Biconicalog Periodic	102	09-24-02
■ - 2396	2520	Wavetek	Signal Generator	6271013	06-05-03
■ - 2478	AWT-18037	Avantek	Preamplifier 8-18 GHz	1001-9226	03-18-03
■ - 2477	AFT-8434	Avantek	Preamplifier 4-8 GHz	2613A92801	03-18-03
■ -	VHAP	Schwarzbeck	Dipole Antenna 30-300	177	N/A
■ - 6717	3116	Electro-Mechanics (EMCO)	Ridge Guide Ant. 18-40 GHz	2005	N/A
■ - 2127	11975A	Hewlett-Packard	Amplifier	2738A01200	1-24-03
■ - 2662	11970K	Hewlett-Packard	External Mixer 18-26.5 GHz	2332A01170	1-17-03
■ - 2662	11970A	Hewlett-Packard	External Mixer 26.5-40 GHz	2332A01861	1-17-03

All measurement instrumentation is traceable to the National Institute of Standards and Technology (NIST) and is calibrated annually.

File No. NC202797, Page 7 of 12

TÜV PRODUCT SERVICE INC 19333 Wild Mountain Road Taylors Falls MN 55084-1758 Tel: 651 638 0297 Fax: 651 638 0298 Rev.No 1.0

Field strength of spurious radiation

Test Setup: TUV Product Services



TEST SETUP FOR EMISSIONS TESTING

WILD RIVER LAB
Large Test Site

Notes:

1. Items shown in dotted lines are located on the floor below the test area. It is 5 meters vertically from the ground floor to the test area.
2. 50 Hz, 60 Hz, and 400 Hz are power panels for alternating current.
3. The antenna may be positioned horizontally 3, 10 or 30 meters from the center of the turntable.
4. The circle is a 6.7 meter diameter turntable.
5. A ground plane is in the plane of this sheet.
6. The test sample is shown in the azimuthal position representing zero degrees.

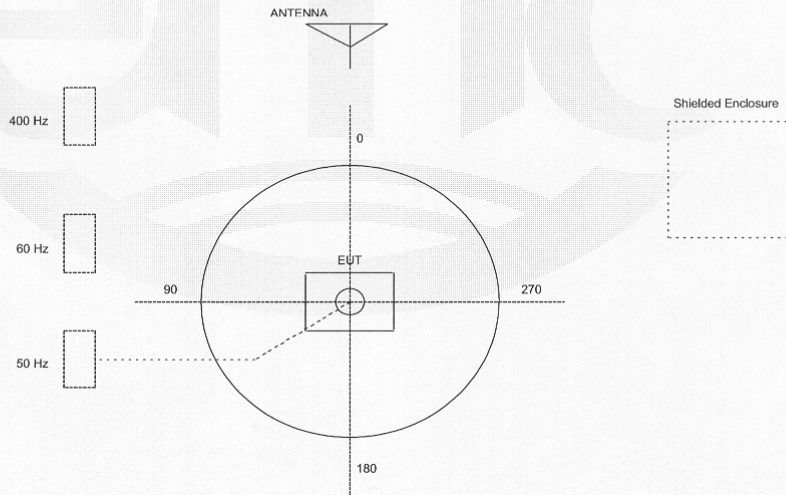

File No. NC202797, Page A3 of A9

TÜV PRODUCT SERVICE INC 19333 Wild Mountain Road Taylors Falls MN 55084-1758 Tel: 651 638 0297 Fax: 651 638 0298 Rev.No 1.0

Field strength of spurious radiation

Test Results: Pass

	Final	Substitution Final	Limit	Margin
Freq. MHz	dBuV/m	dBm	FCC Part 2.1053	dB
81.00	28.2	-66.0	-13 dBm	53.0
98.80	36.9	-57.3	-13 dBm	44.3
107.00	35.8	-58.4	-13 dBm	45.4
108.66	38.2	-56.0	-13 dBm	43.0
109.65	39.1	-55.1	-13 dBm	42.1
128.80	39.0	-55.2	-13 dBm	42.2
129.48	39.5	-54.7	-13 dBm	41.7
142.16	28.7	-65.5	-13 dBm	52.5
230.62	24.2	-70.0	-13 dBm	57.0
276.36	25.1	-69.1	-13 dBm	56.1
281.47	28.6	-65.6	-13 dBm	52.6
5186.00	56.1	-38.1	-13 dBm	25.1

Frequency Stability

Rule Part Number: 2.1055, 21.101(a), 74.961(a)

Stability Requirements: 0.001 % or 10 ppm

Test Procedure: The local oscillator signal that drives the transmit modulator was lightly coupled onto an RF probe and applied to a spectrum analyzer. The frequency of the RF VCO was monitored and recorded for changes due to temperature and input voltage

Test Conditions: Standard Test Conditions

Test Equipment: CPE

DVM	Fluke 87 III Calibration not required
Spectrum Analyzer	Hewlett Packard HP8563E S/N: 3221A00143 Cal Date: 2-12-2002 Cal Due: 2-12-2003
Temperature Chamber	Test Equity 1000 Series Calibration not required
Temperature Sensor	Fluke 89 IV True RMS Multimeter K-Type thermocouple Calibration not required
Computer	Dell Inspiron 3500 Model: TS30T FCC ID: LNQUSA-25774-M5E S/N: 9021946BY11687A
Power Supply	GlobTek, Inc. Model: GT-21097-3013 S/N: 0111018712
Variac	Ohmite Mfg. Co. Variable Transformer CAT. No. VT02F

Frequency Stability

Test Set-Up:

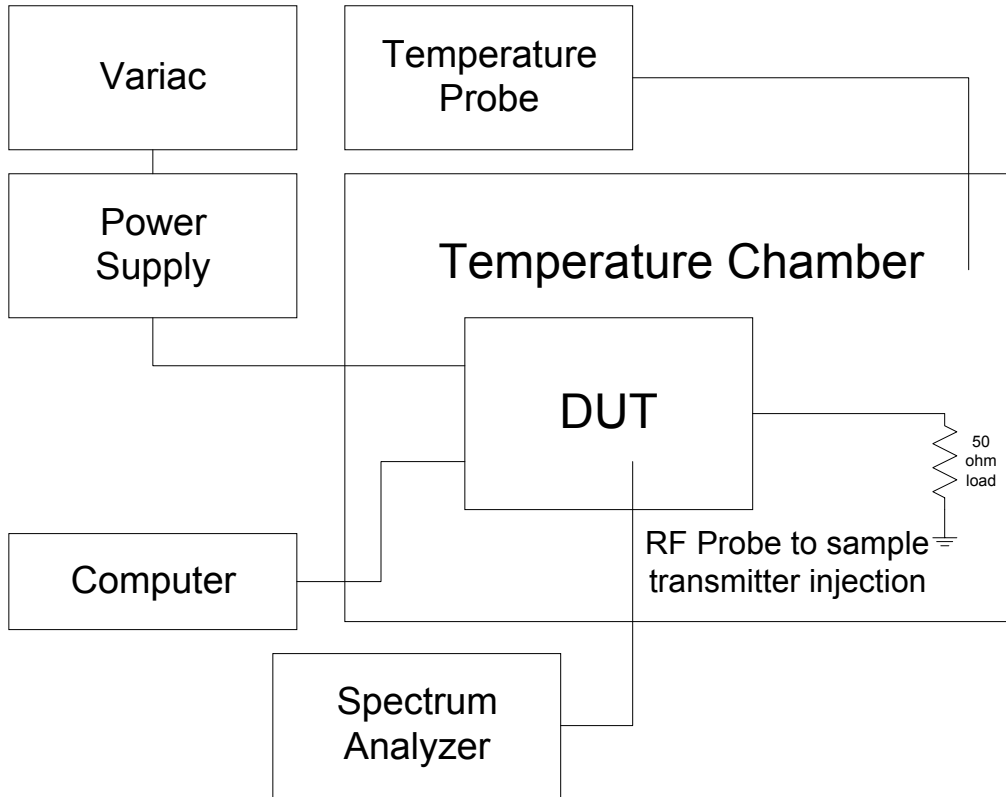

Frequency Stability

Test Conditions: Frequency = 2593 MHz
Supply Voltage = 120 Vac / 60 Hz

2.1055(a) The frequency stability shall be measured with variation of ambient temperature as follows:

(1) From -30° to $+50^{\circ}$ centigrade for all equipment except that specified in paragraphs (a) (2) and (3) of this section.

2.1055(b) Frequency measurements shall be made at the extremes of the specified temperature range and at intervals of not more than 10° centigrade through the range.

Test Results: Temperature Variation

Temperature (°C)	Frequency (Hz)	Frequency Error (Hz)	Frequency Error (%)	Frequency Error (ppm)
-30	2592993200	-6800	-0.000262	-2.622
-20	2592991630	-8370	-0.000323	-3.228
-10	2592993970	-6030	-0.000233	-2.325
0	2592998430	-1570	-0.000061	-0.605
10	2592999030	-970	-0.000037	-0.374
20	2592998570	-1430	-0.000055	-0.551
25	2592997070	-2930	-0.000113	-1.130
30	2592997130	-2870	-0.000111	-1.107
40	2592996200	-3800	-0.000147	-1.465
50	2592995370	-4630	-0.000179	-1.786

Frequency Stability

Test Conditions: Frequency = 2593 MHz
Temperature = 25°C

(d) The frequency stability shall be measured with variation of primary supply voltage as follows:

(1) Vary primary supply voltage from 85 to 115 percent of the nominal value for other than hand carried battery equipment.

Test Results: Supply Voltage Variation

Source Input
Voltage Specification: 120 Vac / 60 Hz

Source Voltage (VAC)	Frequency (Hz)	Frequency Error (Hz)	Frequency Error (%)	Frequency Error (ppm)
102.0	2592997670	-2330	-0.000090	-0.899
106.5	2592997670	-2330	-0.000090	-0.899
111.0	2592997670	-2330	-0.000090	-0.899
115.5	2592997670	-2330	-0.000090	-0.899
120.0	2592997670	-2330	-0.000090	-0.899
124.5	2592997670	-2330	-0.000090	-0.899
129.0	2592997670	-2330	-0.000090	-0.899
133.5	2592997670	-2330	-0.000090	-0.899
138.0	2592997670	-2330	-0.000090	-0.899