

**GREG BEST  
CONSULTING, INC**

5541 Vantage Vista Drive  
Colorado Springs, CO 80919  
719-592-9781

**TEST REPORT**

**TXUD3000A DTV TRANSMITTER TECHNICAL REPORT**

The following information is provided to support the technical performance of the ELETTRONIKA TXUD3000A DTV transmitter. The information is supplied for broadcast TV service according to applicable portions of Part 74.

The following information is provided in support of verification that the transmitter meets the appropriate requirements. Measurements were recorded of spectrum and other appropriate data to demonstrate compliance.

1. Power Output Measurements.
2. Frequency Stability tests versus AC input voltage and temperature
3. Adjacent channel, harmonic and spurious measurements to demonstrate the transmitter meets the DTV stringent emission mask and FCC rule 74.794.
4. Measurement of cabinet radiation for spurs and harmonics as specified in FCC Rule 2.1053 and 2.1057.

Measurements for these parameters were conducted at a power output level of 3000 watts and the range of power for which type certification is sought is 25% of that value (i.e. 750 watts) to the maximum value of 3000 watts.

All test equipment had been calibrated within nominal calibration periods prior to the use of the test equipment.

## RF POWER OUTPUT MEASUREMENTS

The equipment was configured as below shown in Figure 1. The loss through the RF output cable and directional coupler was calibrated at the channel center frequency of 575 MHz. Average power was read on the Rohde and Schwarz URV using the NRP-Z23 Power Sensor.

### Power Measure: block diagram

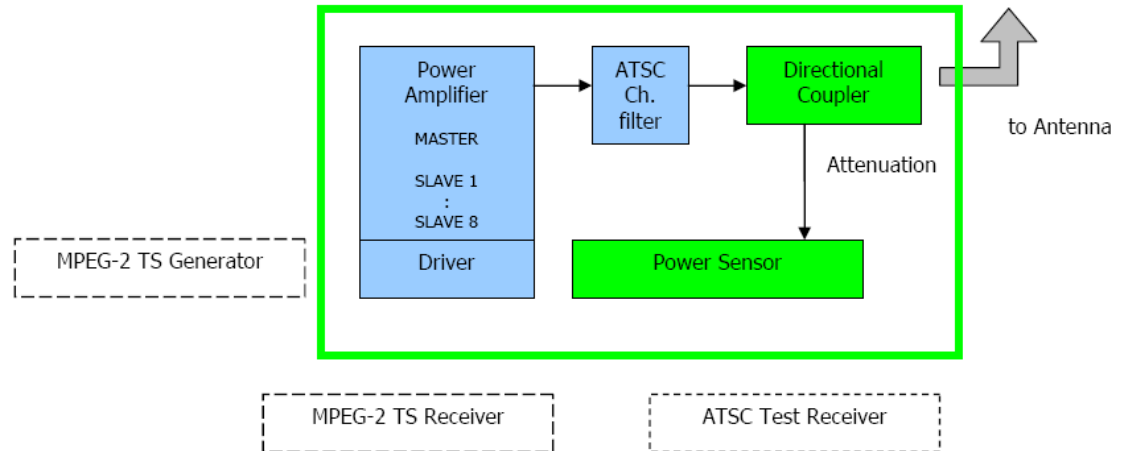

Attenuation: - 61.7 dB (Calibrated Coupler on CH A31)  
Power Sensor reading: 3.2 dBm

Figure 1

The directional coupler and interconnecting cable was taken into account when the power measurement was made.

### Calculation of Output Power.

The output power may be determined by adding the coupling value (including cable loss) to the indicated power read on the power meter.

In this case, 3.2 dBm (or 2.09 milliwatts) indicated reading + 61.7 dB coupling (from calibration of coupler) = 64.9 dBm = 3090 watts

### Frequency Stability versus Line Voltage

The equipment was configured as shown in Figure 1. A variac was inserted in the test configuration between the AC mains service and the TXUD3000A Transmitter exciter. The AC voltage was set-up at 240 volts and the transmitter was energized and adjusted to produce 3000 watts in the RF channel. The nominal frequency was recorded. The variac was adjusted to 85% and 115% of nominal voltage and the corresponding changes in pilot frequency measured on the R & S ETL that was connected to the directional coupler were recorded in the table below.

<b>Line Voltage (Volts)</b>	<b>Measured Pilot Frequency (MHz)</b>
204	572.309441
240 (nominal)	572.309444
276	572.309441

The measured frequency was within the +/- 10 kHz tolerance indicated in FCC rule 74.795.

#### Frequency Stability versus Temperature

The channel 31 transmitter was installed at a client facility and as such, there was no provision for the capability to place the exciter within a temperature chamber. This transmitter uses the exact same exciter as the TXUD2000A, TXUD1000A, and the type certificated TXUD500 transmitters. The data for the TXUD2000A is submitted for documentation of temperature stability purposes.

#### TXUD2000A Temperature Stability tests

For temperature stability measurements the exciter was placed inside the temperature chamber equipped with temperature controller as shown in Figure 1. The transmitter was energized at nominal power and the pilot frequency was measured on the Rhode and Schwarz ETL test set. The temperature was then raised to +50°C, allowed to stabilize for 15 minutes and then cycled to each colder temperature where it was allowed to stabilize for 10 minutes before recording the measured value. Then the measured values were compared against the reference pilot frequency for this channel of 590.309441 MHz.

<b>TEMPERATURE ° C</b>	<b>FREQUENCY (MHz)</b>
25	590.309453
50	590.309480
40	590.309467
30	590.309461
20	590.309440
10	590.309426
0	590.309195

The maximum deviation from the desired pilot frequency over the specified temperature range was -246 Hz which was well within the +/- 10 kHz tolerance identified in FCC rule 74.795.

## Emission Mask Compliance Measurement

To determine emission mask compliance the test equipment configuration shown in Figure 1 was used. The measurement procedure was performed according to IEEE Recommended Practice 1631-2008. The transmitter was tested for compliance with the stringent emission mask classification. The first part of the tests measured the adjacent channel emission and the second part of the tests measured the harmonic and spurious energy. The transmitter was energized at 3000 watts on channel 31 (center frequency of 575 MHz). A reference was established on the ETL spectrum analyzer (using the channel power measurement mode) taking into account the insertion loss of the directional coupler and the interconnecting cables. The minimum displayed average noise level (DANL) for the spectrum analyzer was determined to be -110 dBm in a 10 kHz bandwidth. In order to measure a signal equivalent to the emission mask, the RF sample level must be 93 dB above the DANL using the RBW of 10 kHz. That level will be -17 dBm. In this case, the RF sample level was +3.2 dBm as measured with the channel power measurement mode of the spectrum analyzer so there was ~20 dB of margin in the measurement capability. The bandstop filter frequency response was determined using a spectrum analyzer and tracking analyzer. The insertion loss at the center of each of the twelve 500 kHz segments either side of the main channel was tabulated. The bandstop filter tabulated values were taken into account once the bandstop filter was inserted in the path between the coupler and the spectrum analyzer.

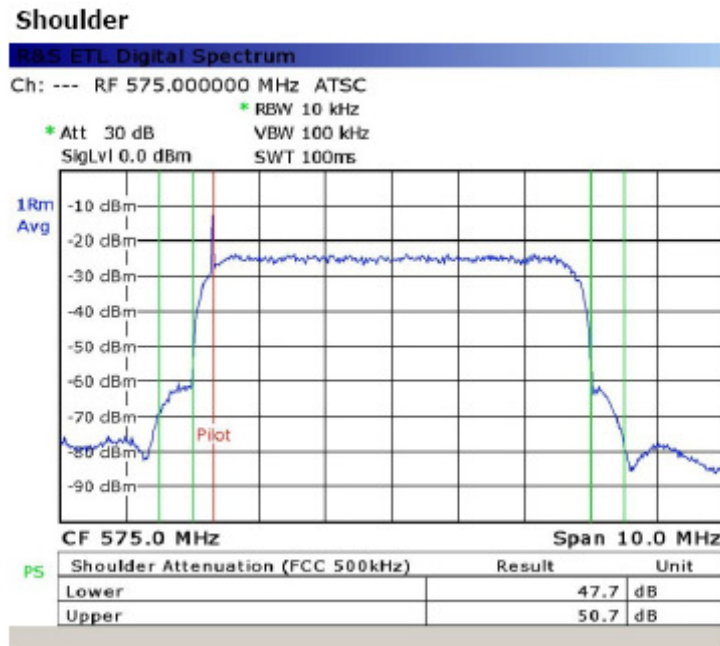

USB and LSB Shoulder Measurement of the desired channel

The next step was to measure the first four 500 kHz subbands on each side of the desired channel. For this part of the measurement, the stopband filter was not necessary. The attenuator on the spectrum analyzer was adjusted so that it was not being overloaded. Once the first four 500 kHz subbands were measured the signal was close to the noise floor for that attenuator setting.

The spectrum analyzer noise floor was subtracted from the measured values when the measured values were within 7 dB of the noise floor.

The next step was to install the bandstop filter in the path from the coupler to the spectrum analyzer and reduce the attenuation so that the emissions in the remaining 500 kHz subbands could be measured.

The attenuator setting of the spectrum analyzer ensured the noise floor was below the measured emissions. Once that was done, the spectrum analyzer attenuator was not changed and the channel power mode was engaged to measure each of the remaining 500 kHz segments (on both sides of the desired channel) using the center frequency of that segment.

The final step was to make any adjustments necessary for the proximity of the noise floor and to take into account the stopband filter loss in that order, and record the values in the table. Then those recorded power levels were subtracted from the total power in the desired channel to determine if they met the emission mask. The attached spreadsheet shows the raw measured values, any correction factors, the noise-floor-corrected measured amplitudes and the final measurement versus the FCC Stringent Emission Mask.

Spectr. Analyzer 10kHz RBW Noise Floor [dBm]	-110,0
Spectr. Analyzer 500kHz RBW Noise Floor [dBm]	-93,0
Noise floor proximity upper threshold [dBm]	-83,0
Noise floor proximity lower threshold [dBm]	-90,0

Min. Sample Level [dBm]	0,1
-------------------------	-----

## ATSC TRANSMISSION MASK COMPLIANCE TEST

### Stringent Mask

Channel Power [dBm]	3,2
Channel no.	31
Center Freq. [MHz]	575

Delta Frequency [MHz]	Frequency [MHz]	Measured Amplitude [dBm]	Noise floor correction	Bandstop Filter Loss [dB]	Corrected Amplitude [dBm]	Amplitude below Channel Power [dB]	FCC Limit [dB]	Pass/Fail
3,25	578,25	-48,0	-48,0	0,0	-48,0	51,2	47,0	Pass
3,75	578,75	-83,0	-83,0	0,0	-83,0	66,2	49,9	Pass
4,25	579,25	-82,0	-82,0	0,0	-82,0	65,2	55,8	Pass
4,75	579,75	-86,0	-86,0	0,0	-86,0	69,2	61,4	Pass
5,25	580,25	-77,0	-77,0	1,4	-75,6	78,8	67,1	Pass
5,75	580,75	-77,5	-77,5	1,2	-76,3	79,5	71,9	Pass
6,25	581,25	-78,0	-78,0	1,2	-76,9	80,1	76,0	Pass
6,75	581,75	-78,0	-78,0	1,1	-76,9	80,1	76,0	Pass
7,25	582,25	-86,0	-87,0	1,0	-86,0	89,2	76,0	Pass
7,75	582,75	-86,0	-87,0	1,0	-86,0	89,2	76,0	Pass
8,25	583,25	-85,0	-85,7	1,0	-84,7	87,9	76,0	Pass
8,75	583,75	-89,0	-91,2	1,0	-90,2	93,4	76,0	Pass
-3,25	571,75	-46,0	-46,0	0,0	-46,0	49,2	47,0	Pass
-3,75	571,25	-57,0	-57,0	0,0	-57,0	60,2	49,9	Pass
-4,25	570,75	-58,0	-58,0	0,0	-58,0	61,2	55,8	Pass
-4,75	570,25	-80,0	-80,0	0,0	-80,0	63,2	61,4	Pass
-5,25	569,75	-73,0	-73,0	1,4	-71,6	74,8	67,1	Pass
-5,75	569,25	-73,0	-73,0	1,2	-71,8	75,0	71,9	Pass
-6,25	568,75	-81,0	-81,0	1,1	-79,9	83,1	76,0	Pass
-6,75	568,25	-85,0	-85,7	1,1	-84,6	87,8	76,0	Pass
-7,25	567,75	-86,0	-87,0	1,0	-86,0	89,2	76,0	Pass
-7,75	567,25	-88,0	-89,7	1,0	-88,7	91,9	76,0	Pass
-8,25	566,75	-90,0	-93,0	1,0	-92,0	95,2	76,0	Pass
-8,75	566,25	-90,0	-93,0	1,0	-92,0	95,2	76,0	Pass

Testing Date:	04/11/2008
Tester:	Vincenzo Ingravallo

DTV Band-Stop Filter	
Manufacturer	Model or Serial Number
MFC	16560-31

## Conducted Harmonic and Spurious Measurements

The same test setup as in Figure 1 was used except that the bandstop filter was replaced with a highpass filter. First the highpass filter is characterized over the spectrum of investigation. The same amplitude reference of 3.2 dBm was obtained using the channel power measurement mode of the spectrum analyzer without the highpass filter in the system. Then the high pass filter was inserted into the path from the directional coupler to the spectrum analyzer. In this case, the highpass filter provided >40 dB attenuation to the main channel signal. The sensitivity of the spectrum analyzer was increased so that the noise floor of the spectrum analyzer was approximately -110 dBm measured using a marker and a 10 kHz resolution bandwidth (RBW). The spectrum from just above the upper adjacent channel to the 5<sup>th</sup> harmonic of the fundamental frequency was investigated to determine if any spurious or harmonic energy existed. The energy above the 5<sup>th</sup> harmonic was all at the noise floor of the spectrum analyzer so no further measurements were made. The highest amplitude measurement of each 500 kHz subband in each harmonic spectrum was taken using the 10 kHz RBW of the spectrum analyzer and the channel power mode (using a measurement bandwidth of 500 kHz) of the spectrum analyzer.

Using the directional coupler calibration factors up to the 5th harmonic, the energy was computed. This value of harmonic energy was compared to the total channel power and the resultant dB<sub>DTV</sub> value was calculated and compared to the -76dB FCC requirement. The results are shown in the table on the next page.

Spectr. Analyzer 10kHz RBW Noise Floor [dBm]	-110,0
Spectr. Analyzer 500kHz RBW Noise Floor [dBm]	-93,0
Noise floor proximity upper threshold [dBm]	-83,0
Noise floor proximity lower threshold [dBm]	-90,0

Min. Sample Level [dBm]	0,1
-------------------------	-----

ATSC TRANSMISSION MASK COMPLIANCE TEST								
Harmonic Emissions								
		Channel Power [dBm]		65,0				
		Channel no.		31				
		Center Freq. [MHz]		575				
Harmonic	Frequency [MHz]	Measured Level [dBm]	Noise floor Channel Power [dBm]	Cable & HPI Loss [dB]	Coupling factor [dBm]	Corrected level [dB]	FCC Required Limit [dB]	Pass/Fail
Xmit freq.	575,00							
2nd	1150,00	-78,0	-110,0	2,5	60,0	80,5	76,0	Pass
3rd	1725,00	-79,0	-110,0	2,3	59,0	82,7	76,0	Pass
4th	2300,00	-78,0	-110,0	2,4	58,0	82,6	76,0	Pass
5th	2875,00	-80,0	-110,0	5,0	55,0	85,0	76,0	Pass

### TXUD3000A HARMONIC AND SPURIOUS MEASUREMENTS

All results meet the -76 dB<sub>DTV</sub> FCC requirement for the stringent emission mask.

Filter attenuation provided at the RNSS bands

FCC rule 74.794 (b) (1) requires that all transmitters operating on channels 22-24, 32-36, 38, and 65-69 provide 85 dB of filtering in the frequency band of 1164-1240 MHz and 1559 to 1610 MHz. The TXUD3000A uses the combination of the bandpass filter supplied with every transmitter and additional low pass filter(s) for transmitters operating on the above mentioned channels. The bandpass filter provides a minimum of 70 dB attenuation at the specified frequencies and the lowpass filters provide an additional 70 dB of filtering. The combination of these two types of filters greatly exceeds the 85 dB required amount of filtering. The combined filter response of the bandstop filter and the lowpass filter is shown below.



## FILTER ATTENUATION FOR TXUD3000A

The test configuration for the response shown below consists of a network analyzer connected to the bandpass filter and two lowpass filters, one to each side of the bandpass filter. The combined emission mask filter was swept using the network analyzer and the out of band rejection at the requested frequencies is >90 dB as shown by the markers. The zero reference is shown as the top line on the network analyzer.

