



Test Report No.: RF121129N022-2



FCC TEST REPORT (PART 22)

REPORT NO.: RF121129N022-2
MODEL NO.: SP100
FCC ID: PH7SP100
RECEIVED: Nov. 29, 2012
TESTED: Nov. 29, 2012~ Jan. 06, 2013
ISSUED: Jan. 06, 2013

APPLICANT: Axesstel, Inc.

ADDRESS: 6815 Flanders Drive, Suite 210, San Diego, CA92121, USA

ISSUED BY: Bureau Veritas Shenzhen Co., Ltd. Dongguan Branch

LAB ADDRESS: No. 34, Chenwulu Section, Guantai Road, Houjie Town, Dongguan City, Guangdong 523942, China

TEST LOCATION: No. 34, Chenwulu Section, Guantai Road, Houjie Town, Dongguan City, Guangdong 523942, China

This report should not be used by the client to claim product certification, approval, or endorsement by A2LA or any government agencies.

This report is for your exclusive use. Any copying or replication of this report to or for any other person or entity, or use of our name or trademark, is permitted only with our prior written permission. This report sets forth our findings solely with respect to the test samples identified herein. The results set forth in this report are not indicative or representative of the quality or characteristics of the lot from which a test sample was taken or any similar or identical product unless specifically and expressly noted. Our report includes all of the tests requested by you and the results thereof based upon the information that you provided to us. You have 60 days from date of issuance of this report to notify us of any material error or omission caused by our negligence, provided, however, that such notice shall be in writing and shall specifically address the issue you wish to raise. A failure to raise such issue within the prescribed time shall constitute your unqualified acceptance of the completeness of this report, the tests conducted and the correctness of the report contents. Unless specific mention, the uncertainty of measurement has been explicitly taken into account to declare the compliance or non-compliance to the specification.

Bureau Veritas Shenzhen Co., Ltd.
Dongguan Branch

No. 34, Chenwulu Section, Guantai Rd.,
Houjie Town, Dongguan City,
Guangdong 523942, China

Tel: +86 769 8593 5656
Fax: +86 769 8593 1080
Email: customerservice.dg@cn.bureauveritas.com



TABLE OF CONTENTS

RELEASE CONTROL RECORD 4

1 CERTIFICATION..... 5

2 SUMMARY OF TEST RESULTS 6

2.1 MEASUREMENT UNCERTAINTY..... 6

3 GENERAL INFORMATION 8

3.1 GENERAL DESCRIPTION OF EUT 8

3.2 CONFIGURATION OF SYSTEM UNDER TEST 9

3.3 DESCRIPTION OF SUPPORT UNITS 9

3.4 TEST ITEM AND TEST CONFIGURATION..... 10

3.5 EUT OPERATING CONDITIONS 11

3.6 GENERAL DESCRIPTION OF APPLIED STANDARDS 11

4 TEST TYPES AND RESULTS 12

4.1 OUTPUT POWER MEASUREMENT 12

4.1.1 LIMITS OF OUTPUT POWER MEASUREMENT 12

4.1.2 TEST PROCEDURES..... 12

4.1.3 TEST SETUP 13

4.1.4 TEST RESULTS..... 14

4.2 FREQUENCY STABILITY MEASUREMENT 15

4.2.1 LIMITS OF FREQUENCY STABILITY MEASUREMENT 15

4.2.2 TEST PROCEDURE 15

4.2.3 TEST SETUP 15

4.2.4 TEST RESULTS..... 16

4.3 OCCUPIED BANDWIDTH MEASUREMENT 17

4.3.1 TEST PROCEDURES..... 17

4.3.2 TEST SETUP 17

4.3.3 TEST RESULTS..... 18

4.4 BAND EDGE MEASUREMENT..... 19

4.4.1 LIMITS OF BAND EDGE MEASUREMENT 19

4.4.2 TEST SETUP 19

4.4.3 TEST PROCEDURES..... 19

4.4.4 TEST RESULTS..... 20

4.5 CONDUCTED SPURIOUS EMISSIONS 21

4.5.1 LIMITS OF CONDUCTED SPURIOUS EMISSIONS MEASUREMENT..... 21

4.5.2 TEST PROCEDURE 21

4.5.3 TEST SETUP 21

4.6 RADIATED EMISSION MEASUREMENT 23

4.6.1 LIMITS OF RADIATED EMISSION MEASUREMENT..... 23

4.6.2 TEST PROCEDURES..... 23



**BUREAU
VERITAS**

Test Report No.: RF121129N022-2

4.6.3	DEVIATION FROM TEST STANDARD	23
4.6.4	TEST SETUP	24
4.6.5	TEST RESULTS.....	25
5	PHOTOGRAPHS OF THE TEST CONFIGURATION	26
6	INFORMATION ON THE TESTING LABORATORIES.....	27
7	APPENDIX A – MODIFICATIONS RECORDERS FOR ENGINEERING CHANGES TO THE EUT BY THE LAB	28



**BUREAU
VERITAS**

Test Report No.: RF121129N022-2

RELEASE CONTROL RECORD

ISSUE NO.	REASON FOR CHANGE	DATE ISSUED
RF121129N022-2	Original release	Jan. 06, 2013



1 CERTIFICATION

PRODUCT: SP100 Smart Phone
MODEL: SP100
BRAND: Axesstel
APPLICANT: Axesstel, Inc.
TESTED: Nov. 29, 2012~ Jan. 06, 2013
TEST SAMPLE: Production Unit
STANDARDS: FCC PART 22, Subpart H

The above equipment (model: SP100) has been tested by **Bureau Veritas Shenzhen Co., Ltd. Dongguan Branch**, and found compliance with the requirement of the above standards. The test record, data evaluation & Equipment Under Test (EUT) configurations represented herein are true and accurate accounts of the measurements of the sample's EMC characteristics under the conditions specified in this report.

TESTED BY :  , **DATE** : Jan. 06, 2013
Kent Liu / Project Engineer

APPROVED BY :  , **DATE** : Jan. 06, 2013
Sam Tung / Technical Manager



2 SUMMARY OF TEST RESULTS

The EUT has been tested according to the following specifications:

APPLIED STANDARD: FCC Part 22 & Part 2			
STANDARD SECTION	TEST TYPE	RESULT	REMARK
2.1046 22.913 (a)	Effective Radiated Power	PASS	Meet the requirement of limit.
2.1055 22.355	Frequency Stability	PASS	Meet the requirement of limit.
2.1049	Occupied Bandwidth	PASS	Meet the requirement of limit.
22.917	Band Edge Measurements	PASS	Meet the requirement of limit.
2.1051 22.917	Conducted Spurious Emissions	PASS	Meet the requirement of limit.
2.1053 22.917	Radiated Spurious Emissions	PASS	Meet the requirement of limit. Minimum passing margin is -30.53dB at 1672MHz.

2.1 MEASUREMENT UNCERTAINTY

Where relevant, the following measurement uncertainty levels have been estimated for tests performed on the EUT as specified in CISPR 16-4-2:

MEASUREMENT	FREQUENCY	UNCERTAINTY
Conducted emissions	9kHz~30MHz	2.94dB
Radiated emissions	30MHz ~ 1GHz	3.64dB
	1GHz ~ 18GHz	2.2dB
	18GHz ~ 40GHz	1.94dB

This uncertainty represents an expanded uncertainty expressed at approximately the 95% confidence level using a coverage factor of k=2.



2.2 TEST SITE AND INSTRUMENTS

DESCRIPTION & MANUFACTURER	MODEL NO.	SERIAL NO.	DATE OF CALIBRATION	DUE DATE OF CALIBRATION
Spectrum Analyzer Agilent	E4446A	MY46180622	May 02, 12	May 01, 13
Test Receiver ROHDE & SCHWARZ	ESVD	841431/004	May 15,12	May 14,13
Bilog Antenna TESEQ	CBL 6111D	27089	July 16,12	July 15,13
Horn Antenna EMCO	3117	00062558	Oct.18,12	Oct.17,13
10m Semi-anechoic Chamber ETS-LINDGREN	21.4m*12.1m*8.8m	NSEMC006	Mar. 24,12	Mar. 23,13
Signal Amplifier EMCI	EMC330	980095	Nov. 02,12	Nov. 01,13
Signal Amplifier SONOMA	310N	186955	Mar. 14,12	Mar. 13,13
Signal Amplifier HP	8449B	3008A00409	May 31,12	May 30,13
Spectrum Analyzer Agilent	E7405A	MY45118807	May 15,12	May 14,13
Digital Multimeter FLUKE	15B	A1220010DG	Jan. 14,12	Jan. 13,13
Power Meter Anritsu	ML2495A	1139001	Nov. 05,12	Nov. 04,13
Universal Radio Communication Tester Rohde & Schwarz	CMU 200	123259	Apr. 16,12	Apr. 15,13
Test software ADT	ADT_Radiated_V7. 6.15	N/A	N/A	N/A

- NOTE:**
1. The calibration interval of the above test instruments is 12 months and the calibrations are traceable to CEPREI/CHINA and NIM/CHINA.
 2. The test was performed in Dongguan Chamber 10m.
 3. The horn antenna are used only for the measurement of emission frequency above 1GHz if tested.



3 GENERAL INFORMATION

3.1 GENERAL DESCRIPTION OF EUT

EUT	SP100 Smart Phone
MODEL NO.	SP100
POWER SUPPLY	DC 5V (adapter or host equipment) DC 3.7V (Li-ion battery)
MODULATION TYPE	CDMA: QPSK, OQPSK, HPSK
FREQUENCY RANGE	CDMA: 824.7MHz ~ 848.31MHz
MAX. ERP POWER	0.46 Watts
ANTENNA TYPE	PIFA Antenna; 0dBi gain
I/O PORTS	Refer to user's manual
CABLE SUPPLIED	USB cable: Unshielded, Detachable, 0.95m Earphone cable: Unshielded, Detachable, 1.2m
ACCESSORY DEVICES	Refer to user's manual

NOTE:

1. Bluetooth, Wlan, CDMA technologies were used for the EUT.
2. The EUT was powered by the following adapter:

ADAPTER	
BRAND:	Axesstel
MODEL:	TXD-C01-5.0/650U
INPUT:	AC 100-240V, 0.15A
OUTPUT:	DC 5V, 650m A
DC LINE:	USB CABLE: UNSHIELDED, DETACHABLE, 1.0M

3. The above EUT information was declared by manufacturer and for more detailed feature description, please refer to the manufacturer's specifications or User's Manual.



3.2 CONFIGURATION OF SYSTEM UNDER TEST

FOR RADIATION EMISSION TEST

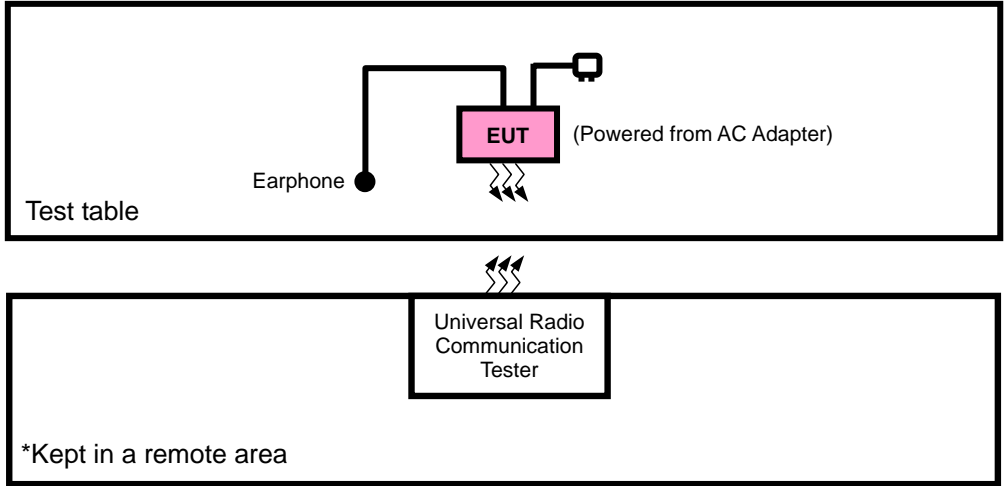

3.3 DESCRIPTION OF SUPPORT UNITS

The EUT has been tested as an independent unit together with other necessary accessories or support units. The following support units or accessories were used to form a representative test configuration during the tests.

NO.	PRODUCT	BRAND	MODEL NO.	SERIAL NO.	FCC ID
1	N/A				

NO.	SIGNAL CABLE DESCRIPTION OF THE ABOVE SUPPORT UNITS
1	N/A

NOTE: All power cords of the above support units are non shielded (1.8m).



3.4 TEST ITEM AND TEST CONFIGURATION

Pre-Scan has been conducted to determine the worst-case mode from all possible combinations between available modulations, data rates, XYZ axis and antenna ports. The worst case was found when positioned on X- axis for ERP and radiated emission. Following channel(s) was (were) selected for the final test as listed below:

EUT CONFIGURE MODE	DESCRIPTION
A	EUT + Adapter + Earphone with CDMA link
B	EUT + Battery + Earphone with CDMA link
C	EUT + USB Charger + Earphone with CDMA link

EUT CONFIGURE MODE	TEST ITEM	AVAILABLE CHANNEL	TESTED CHANNEL	MODE
A	ERP	1013 to 777	1013, 384, 777	RC3+SO55
A	FREQUENCY STABILITY	1013 to 777	384	RC3+SO55
A	OCCUPIED BANDWIDTH	1013 to 777	1013, 384, 777	RC3+SO55
A	BAND EDGE	1013 to 777	1013, 777	RC3+SO55
A	CONDCUDETED EMISSION	1013 to 777	384	RC3+SO55
A	RADIATED EMISSION	1013 to 777	384	RC3+SO55

TEST CONDITION:

TEST ITEM	ENVIRONMENTAL CONDITIONS	TEST VOLTAGE	TESTED BY
ERP	21deg. C, 62%RH	5Vdc from adapter	Venless Long
FREQUENCY STABILITY	21deg. C, 62%RH	5Vdc from adapter	Venless Long
OCCUPIED BANDWIDTH	21deg. C, 62%RH	5Vdc from adapter	Venless Long
BAND EDGE	21deg. C, 62%RH	5Vdc from adapter	Venless Long
CONDCUDETED EMISSION	21deg. C, 62%RH	5Vdc from adapter	Venless Long
RADIATED EMISSION	25deg. C, 60%RH	5Vdc from adapter	Venless Long



Test Report No.: RF121129N022-2

3.5 EUT OPERATING CONDITIONS

The EUT makes a call to the communication simulator. The communication simulator station system controlled a EUT to export maximum output power under transmission mode and specific channel frequency

3.6 GENERAL DESCRIPTION OF APPLIED STANDARDS

The EUT is a RF product. According to the specifications of the manufacturer, it must comply with the requirements of the following standards:

FCC 47 CFR Part 2

FCC 47 CFR Part 22

ANSI/TIA/EIA-603-C 2004

NOTE: All test items have been performed and recorded as per the above standards.

4 TEST TYPES AND RESULTS

4.1 OUTPUT POWER MEASUREMENT

4.1.1 LIMITS OF OUTPUT POWER MEASUREMENT

Mobile / Portable station are limited to 7 watts e.r.p.

4.1.2 TEST PROCEDURES

EIRP / ERP MEASUREMENT:

- a. All measurements were done at low, middle and high operational frequency range. RBW and VBW is 5MHz for CDMA mode.
- b. Substitution method is used for E.I.R.P measurement. In the semi-anechoic chamber, EUT placed on the 0.8m height of Turn Table, rotated the table around 360 degrees to search the maximum radiation power and receiver antenna shall be rotated vertical and horizontal polarization and moved height from 1m to 4m to find the maximum polar radiated power. The “Read Value” is the spectrum reading the maximum power value.
- c. The substitution horn antenna is substituted for EUT at the same position and signals generator export the CW signal to the substitution antenna via a tx cable. Rotated the Turn Table and moved receiving antenna to find the maximum radiation power. Adjust output power level of S.G to get a Value of spectrum reading equal to “Read Value “ of step b. Record the power level of S.G
- d. $EIRP = \text{Output power level of S.G} - \text{TX cable loss} + \text{Antenna gain of substitution horn.}$ E.R.P power can be calculated form E.I.R.P power by subtracting the gain of dipole, $E.R.P \text{ power} = E.I.R.P \text{ power} - 2.15\text{dBi.}$

CONDUCTED POWER MEASUREMENT:

The EUT was set up for the maximum power with CDMA link data modulation and link up with simulator. Set the EUT to transmit under low, middle and high channel and record the power level shown on simulator.

4.1.3 TEST SETUP

EIRP / ERP MEASUREMENT:

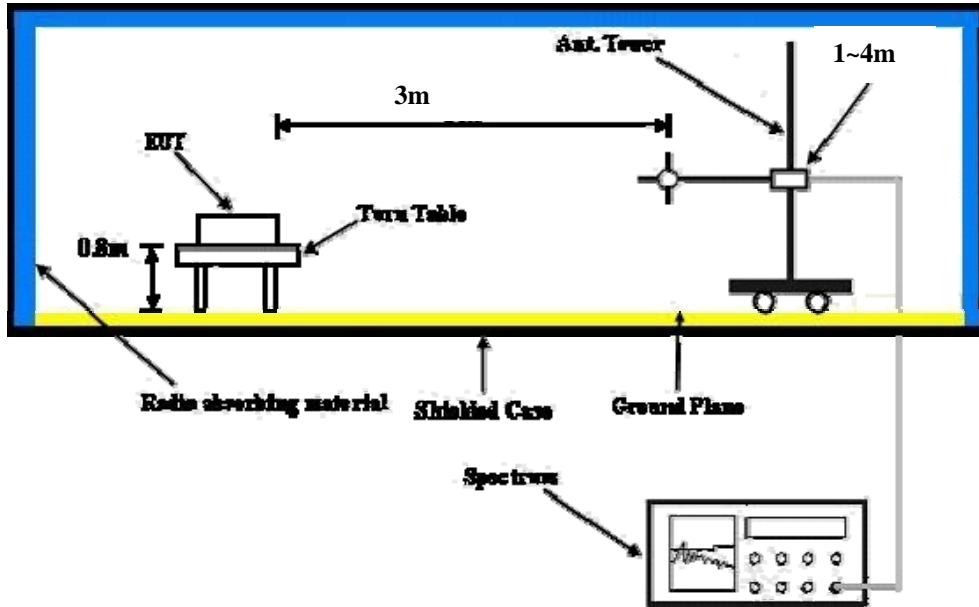

For the actual test configuration, please refer to the attached file (Test Setup Photo).

CONDUCTED POWER MEASUREMENT:

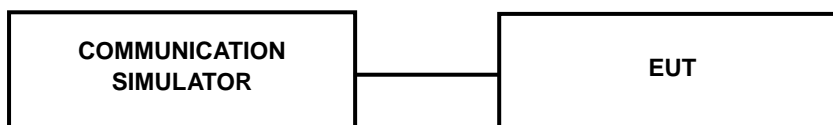

For the actual test configuration, please refer to the attached file (Test Setup Photo).



4.1.4 TEST RESULTS

CONDUCTED OUTPUT POWER (dBm)

Band	CDMA2000 BC0		
Channel	1013	384	777
Frequency (MHz)	824.7	836.52	848.31
RC1+SO55	23.49	23.22	23.36
RC3+SO55	23.72	23.49	23.67
RC3+SO32(+ F-SCH)	23.59	23.40	23.55
RC3+SO32(+SCH)	23.58	23.41	23.52
RTAP 153.6	23.59	23.27	23.45

ERP POWER (dBm)

FOR 1xRTT RC3+SO55 MODE

Channel	Frequency (MHz)	LVL (dBm)	Correction Factor(dB)	ERP(dBm)	ERP(W)	Polarization (H/V)
1013	824.7	-4.86	32.88	25.87	0.39	H
384	836.52	-5.27	33.73	26.31	0.43	H
777	848.31	-5.43	34.17	26.59	0.46	H
1013	824.7	-10.41	35.15	22.59	0.18	V
384	836.52	-10.91	35.27	22.21	0.17	V
777	848.31	-11.15	35.29	21.99	0.16	V

- REMARKS:** 1. ERP Output Power (dBm) = LVL (dBm) + Correction Factor (dB) -2.15 (dB)
 2. Correction factor (dB) = Free Space Loss + Antenna Factor + Cable Loss.

4.2 FREQUENCY STABILITY MEASUREMENT

4.2.1 LIMITS OF FREQUENCY STABILITY MEASUREMENT

1.5 ppm is for base and fixed station. 2.5 ppm is for mobile station.

4.2.2 TEST PROCEDURE

- a. Device is placed at the oven room. The oven room could control the temperatures and humidity. Power warm up is at least 15 min and power applied should perform before recording frequency error.
- b. EUT is connected the external power supply to control the DC input power. The test voltage range is from minimum to maximum working voltage. Each step shall be record the frequency error rate.
- c. The temperature range step is 10 degrees in this test items. All temperature levels shall be hold the $\pm 0.5^{\circ}\text{C}$ during the measurement testing. The each temperature step shall be at least 0.5 hours, consider the EUT could be test under the stability condition.

NOTE: The frequency error was recorded frequency error from the communication simulator.

4.2.3 TEST SETUP

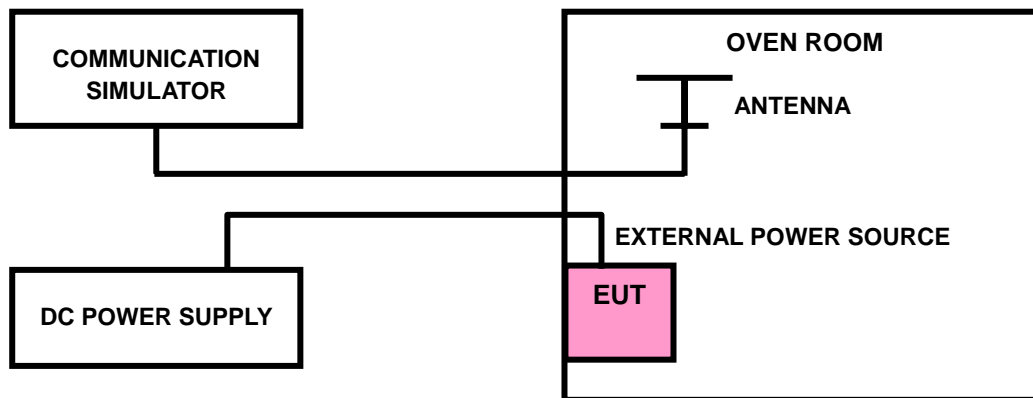



4.2.4 TEST RESULTS

FREQUENCY ERROR vs. VOLTAGE

VOLTAGE (Volts)	FREQUENCY ERROR (ppm)	LIMIT (ppm)
3.7	0.0021	2.5
3.5	0.0021	2.5
4.2	0.0031	2.5

NOTE: The applicant defined the normal working voltage of the battery is from 3.5Vdc to 4.2Vdc.

FREQUENCY ERROR vs. TEMPERATURE

TEMP. (°C)	FREQUENCY ERROR (ppm)	LIMIT (ppm)
-20	0.0019	2.5
-10	0.0024	2.5
0	0.0021	2.5
10	0.0026	2.5
20	0.0021	2.5
30	0.0018	2.5
40	0.0024	2.5
50	0.0021	2.5
55	0.0023	2.5

4.3 OCCUPIED BANDWIDTH MEASUREMENT

4.3.1 TEST PROCEDURES

The EUT makes a call to the communication simulator. All measurements were done at low, middle and high operational frequency range. The communication simulator station system controlled a EUT to export maximum output power under transmission mode and specific channel frequency. Use OBW measurement function of Spectrum analyzer to measure 99 % occupied bandwidth.

4.3.2 TEST SETUP

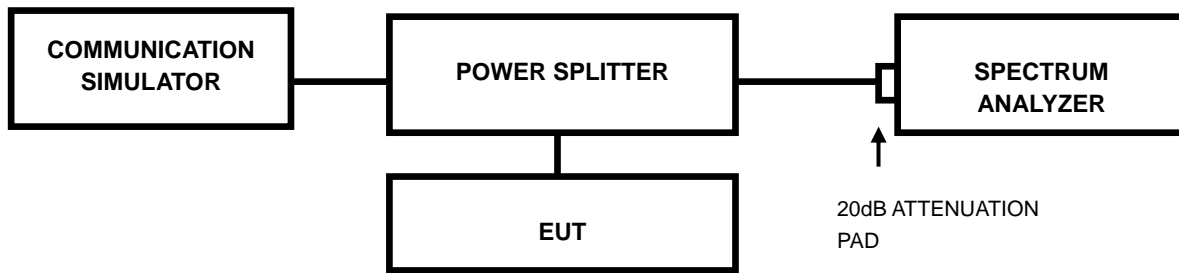



4.3.3 TEST RESULTS

1xRTT RC3+SO55 MODE

CHANNEL	FREQUENCY (MHz)	99% OCCUPIED BANDWIDTH (MHz)
1013	824.70	1.281
384	836.52	1.287
777	848.31	1.281

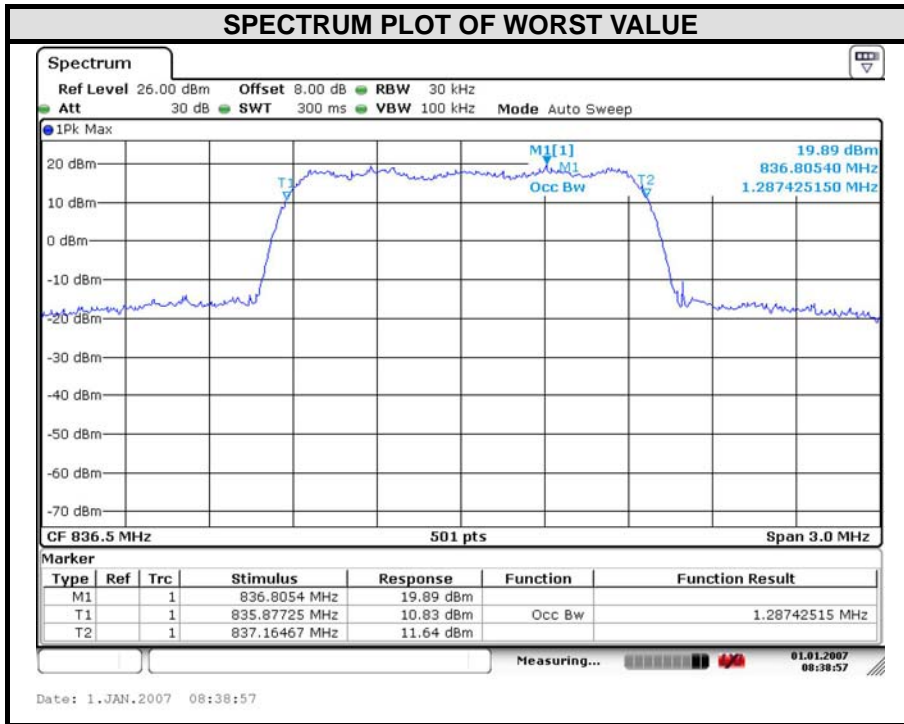

4.4 BAND EDGE MEASUREMENT

4.4.1 LIMITS OF BAND EDGE MEASUREMENT

Power of any emission outside of the authorized operating frequency ranges must be attenuated below the transmitting power (P) by a factor of at least $43 + 10 \log(P)$ dB. In the 1 MHz bands immediately outside and adjacent to the frequency block a resolution bandwidth of at least one percent of the emission bandwidth of the fundamental emission of the transmitter may be employed.

4.4.2 TEST SETUP

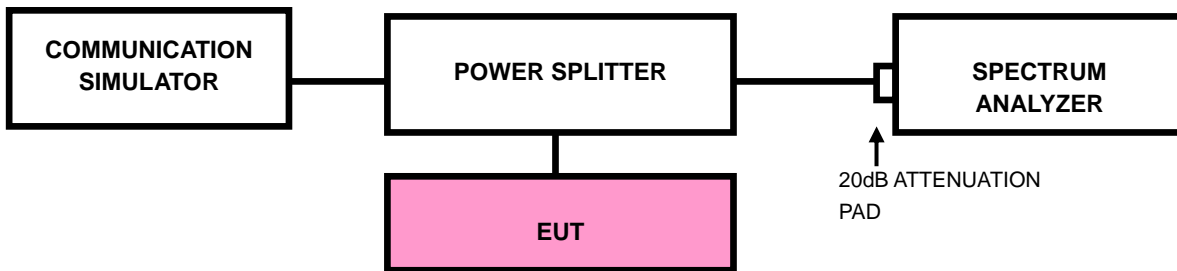

4.4.3 TEST PROCEDURES

- All measurements were done at low and high operational frequency range.
- The center frequency of spectrum is the band edge frequency and span is 1 MHz. The RBW was replaced by 10 kHz, due to the spectrum analyzer IF-Filter including an excess of the limit. A worst case correction factor of $10 \log (1\% \text{ BW/measurement RBW})$ was implemented.
- Record the max trace plot into the test report.



BUREAU VERITAS

Test Report No.: RF121129N022-2

4.4.4 TEST RESULTS

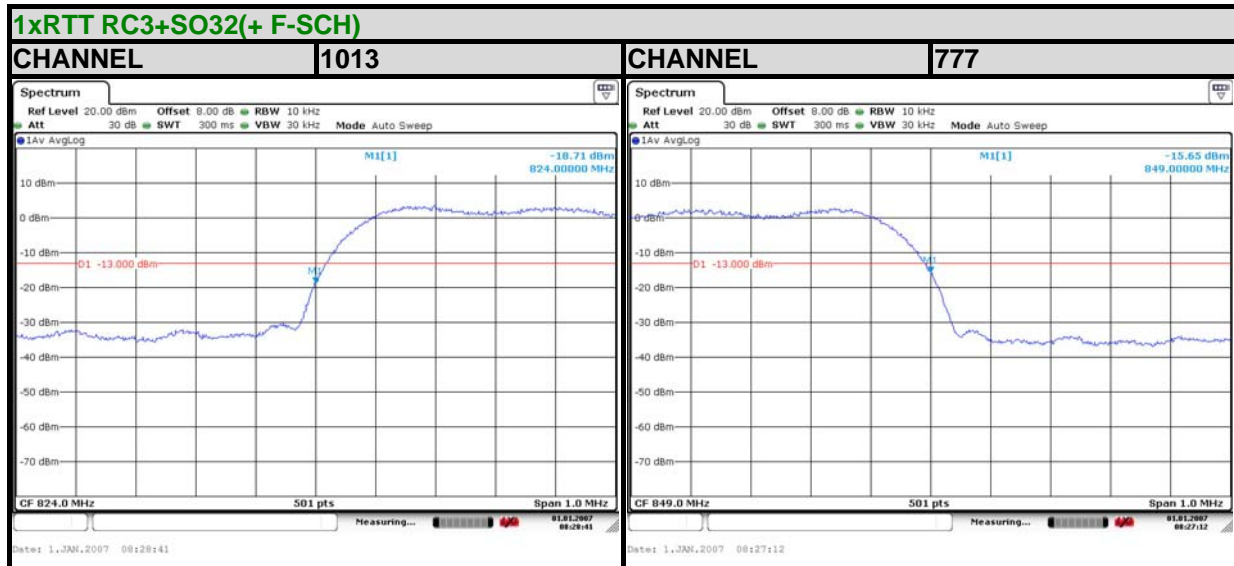

Bureau Veritas Shenzhen Co., Ltd.
Dongguan Branch

No. 34, Chenwulu Section, Guantai Rd.,
Houjie Town, Dongguan City,
Guangdong 523942, China

Tel: +86 769 8593 5656
Fax: +86 769 8593 1080
Email: customerservice.dg@cn.bureauveritas.com

4.5 CONDUCTED SPURIOUS EMISSIONS

4.5.1 LIMITS OF CONDUCTED SPURIOUS EMISSIONS MEASUREMENT

The power of any emission outside of the authorized operating frequency ranges must be attenuated below the transmitting power (P) by a factor of at least $43 + 10 \log(P)$ dB. The emission limit equal to -13dBm .

4.5.2 TEST PROCEDURE

- a. The EUT makes a phone call to the communication simulator. All measurements were done at low, middle and high operational frequency range.
- b. Measuring frequency range is from 9 kHz to 9GHz. 20dB attenuation pad is connected with spectrum. RBW=1MHz and VBW=3MHz is used for conducted emission measurement.

4.5.3 TEST SETUP

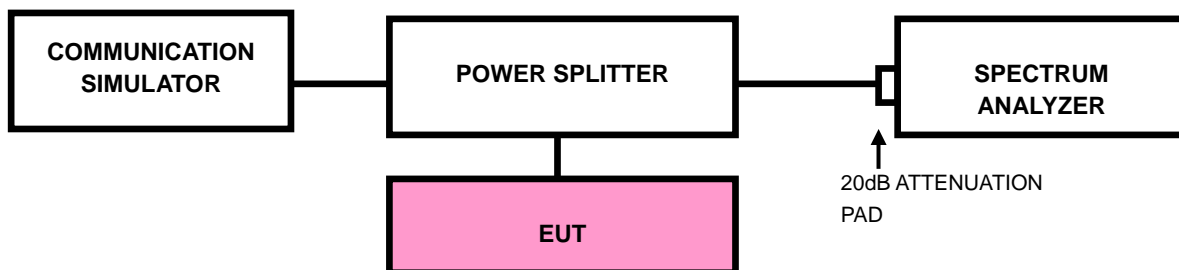



4.5.4 TEST RESULTS

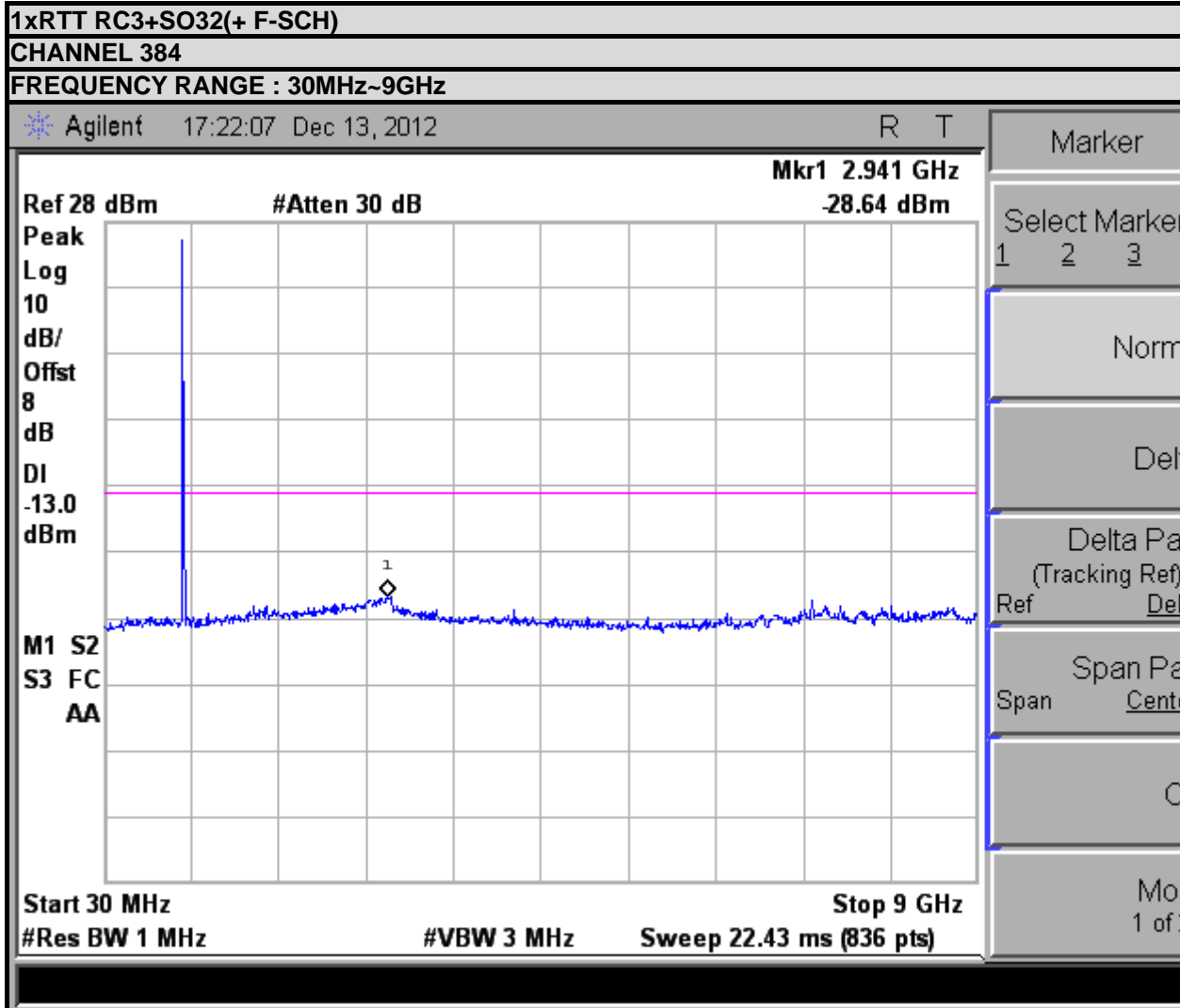

4.6 RADIATED EMISSION MEASUREMENT

4.6.1 LIMITS OF RADIATED EMISSION MEASUREMENT

The power of any emission outside of the authorized operating frequency ranges must be attenuated below the transmitting power (P) by a factor of at least $43 + 10 \log(P)$ dB. The emission limit equal to -13dBm .

4.6.2 TEST PROCEDURES

- a. Substitution method is used for E.I.R.P measurement. In the semi-anechoic chamber, EUT placed on the 0.8m height of Turn Table, rotated the table around 360 degrees to search the maximum radiation power and receiver antenna shall be rotated vertical and horizontal polarization and moved height from 1m to 4m to find the maximum polar radiated power. The “Read Value” is the spectrum reading the maximum power value.
- b. The substitution horn antenna is substituted for EUT at the same position and signals generator export the CW signal to the substitution antenna via a TX cable. Rotated the Turn Table and moved receiving antenna to find the maximum radiation power. Adjust output power level of S.G to get a Value of spectrum reading equal to “Read Value “ of step a. Record the power level of S.G
- c. $\text{EIRP} = \text{Output power level of S.G} - \text{TX cable loss} + \text{Antenna gain of substitution horn}$.
- d. E.R.P power can be calculated form E.I.R.P power by subtracting the gain of dipole, $\text{E.R.P power} = \text{E.I.R.P power} - 2.15\text{dBi}$.

NOTE: The resolution bandwidth and video bandwidth of test receiver/spectrum analyzer is 1MHz/3MHz.

4.6.3 DEVIATION FROM TEST STANDARD

No deviation



4.6.4 TEST SETUP

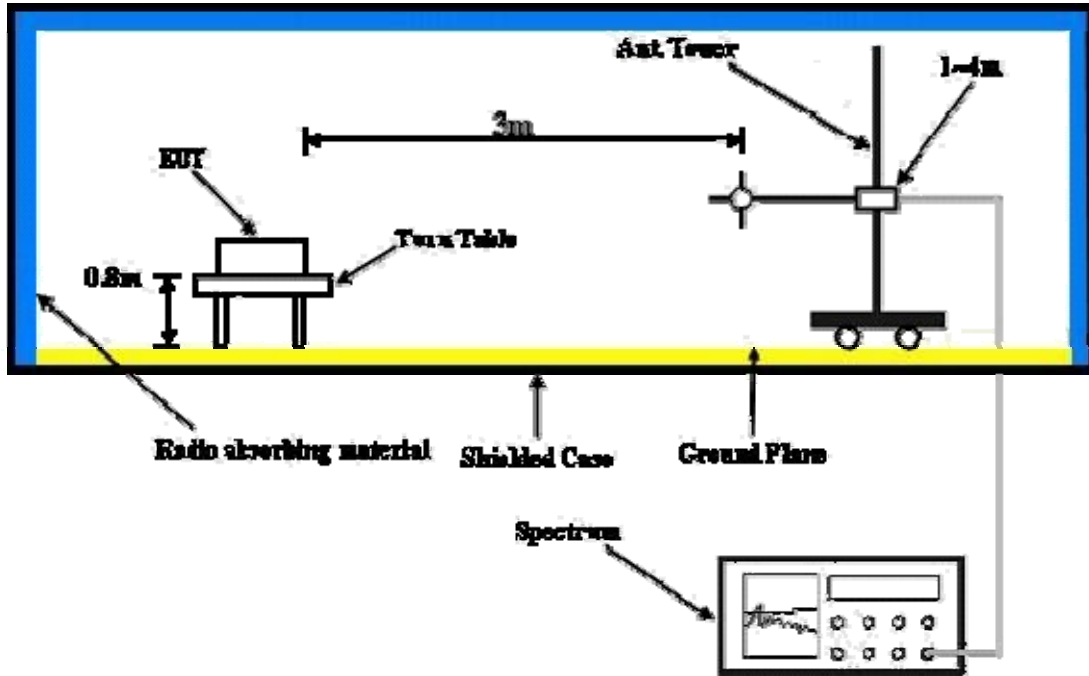

For the actual test configuration, please refer to the attached file (Test Setup Photo).



4.6.5 TEST RESULTS

1xRTT RC3+SO32(+ F-SCH)

FREQUENCY RANGE	Above 1000MHz	TEST VOLTAGE	DC 5V from adapter input AC120V, 60Hz
ENVIRONMENTAL CONDITIONS	26deg. C, 65%RH	TESTED BY	Venless Long

ANTENNA POLARITY & TEST DISTANCE: HORIZONTAL AT 3 M						
No.	Freq. (MHz)	SPA READING (dBm)	Limit (dBm)	S.G Power Value (dBm)	Correction Factor (dB)	ERP (dBm)
1	1672	-41.23	-13	-36.34	0.46	-35.88
2	2509	-51.21	-13	-42.64	0.17	-42.47
3	3345	-63.57	-13	-63.53	1.49	-62.04
ANTENNA POLARITY & TEST DISTANCE: VERTICAL AT 3 M						
No.	Freq. (MHz)	SPA READING (dBm)	Limit (dBm)	S.G Power Value (dBm)	Correction Factor (dB)	ERP (dBm)
1	1672	-39.1	-13	-30.99	0.46	-30.53
2	2509	-53.3	-13	-45.03	0.17	-44.86
3	3345	-59.9	-13	-50.63	1.449	-49.14

REMARKS:

1. ERP (dBm) = S.G Value (dBm) + Correction Factor (dB).
2. Correction Factor (dB) = Substitution Antenna Gain (dB) + Cable Loss (dB) - 2.15 (dB)



**BUREAU
VERITAS**

Test Report No.: RF121129N022-2

5 PHOTOGRAPHS OF THE TEST CONFIGURATION

Please refer to the attached file (Test Setup Photo).



Test Report No.: RF121129N022-2

6 INFORMATION ON THE TESTING LABORATORIES

We, Bureau Veritas Shenzhen Co., Ltd. Dongguan Branch, were founded in 2002 to provide our best service in EMC, Radio, Telecom and Safety consultation. Our laboratories are accredited and approved according to ISO/IEC 17025.

If you have any comments, please feel free to contact us at the following:

Dongguan EMC/RF Lab:

Tel: +86-769-85935656

Fax: +86-769-85931080

Email: customerservice.dg@cn.bureauveritas.com

Web Site: www.adt.com.tw

The address and road map of all our labs can be found in our web site also.



**BUREAU
VERITAS**

Test Report No.: RF121129N022-2

7 APPENDIX A – MODIFICATIONS RECORDERS FOR ENGINEERING CHANGES TO THE EUT BY THE LAB

No any modifications are made to the EUT by the lab during the test.

---END---