



47 CFR PART 22 SUBPART H

TEST REPORT

Fixed Wireless Phone on CDMA 800MHz

Model Name: PXA20
Trade Name: Axesstel Inc
Report No.: SH09110036R02
FCC ID: PH7PXA20

prepared for

Axesstel Inc

6815 Flanders Drive, #210, San Diego, CA 92121, USA

Shenzhen Electronic Product Quality Testing Center

Morlab Laboratory

3/F, Electronic Testing Building, Shahe Road, Xili,

Nanshan District, Shenzhen, 518055 P. R. China

Tel: +86 755 86130398

Fax: +86 755 86130218



NOTE: This test report can be duplicated completely for the legal use with the approval of the applicant, it shall not be reproduced except in full, without the written approval of Shenzhen Morlab Communications Technology Co., Ltd. Any objections should be raised to us within thirty workdays since the date of issue.



TABLE OF CONTENTS

1. TEST RESULT CERTIFICATION4

2. GENERAL INFORMATION5

2.1 Equipment under Test (EUT) Description5

2.2 Test Standards and Results6

2.3 Facilities and Accreditations7

2.3.1 Facilities7

2.3.2 Test Equipments7

2.3.3 Test Environment Conditions7

2.4 47 CFR Part 2, Part 22H Requirements8

2.4.1 Conducted Related Tests8

2.4.2 Radiated Power and Spurious Emission Tests9

2.4.3 Frequency Stability Test10

2.5 Frequencies11

2.5.1 Requirement11

2.5.2 Procedure11

2.5.3 Test modes12

2.5.4 Test result12

2.6 Conducted RF Output Power17

2.6.1 Requirement17

2.6.2 Test Procedure17

2.6.3 Test Result17

2.7 Occupied Bandwidth24

2.7.1 Occupied Bandwidth Definition24

2.7.2 Test Procedure24

2.7.3 Test Result25

2.8 Plot for Band-edge32

2.8.1 Test modes32

2.8.2 Test result34

2.9 Conducted Spurious Emission36

2.9.1 Requirement36



2.9.2 Test Procedure	37
2.9.3 Test modes	38
2.9.4 Test result	39
2.10 Transmitter Radiated Power (EIRP/ERP).....	45
2.10.1 Requirement	45
2.10.2 Test Procedure	45
2.10.3 Test Result	46
2.11 Radiated Spurious Emission.....	48
2.11.1 Requirement	48
2.11.2 Test Procedure	48
2.11.3 Test modes	49
2.11.4 Test plots.....	50
2.12 Frequency Stability	53
2.12.1 Frequency Stability Requirement.....	53
2.12.2 Test Procedure	53
2.12.3 Test modes	54
2.12.4 Test Result	55



1. Test Result Certification

Equipment under Test: Fixed Wireless Phone on CDMA 800MHz
 Trade Name: Axesstel Inc
 Model Name: PXA20
 FCC ID: PH7PXA20
 Applicant: Axesstel Inc
 6815 Flanders Drive, #210, San Diego, CA 92121, USA
 Manufacturer: Asiatelco Technologies Co.
 #289 Bisheng Rd, Bld-8, 3F, Zhangjiang Hi-Tech Park, Pudong,
 Shanghai, China
 Test Standards: 47 CFR Part 2
 47 CFR Part 22 Subpart H
 Test Result: PASS

*** We Hereby Certify That:**

The equipment under test was tested by Shenzhen Morlab Communications Technology Co., Ltd. The test data, data evaluation, test procedures and equipment configurations shown in this report were made in accordance with the requirement of related FCC rules.

The test results of this report only apply for the tested sample equipment identified above. The test report shall be invalid without all the signatures of the test engineer, the reviewer and the approver.

Tested by:	<i>Bao Yinquan</i> Bao Yinquan	Dated:	<i>2009.12.15</i> 2009/12/15
Reviewed by:	<i>Zhang Jun</i> Zhang Jun	Dated:	<i>2009.12.15</i> 2009/12/15
Approved by:	<i>Su Feng</i> Su Feng	Dated:	<i>2009.12.15</i> 2009/12/15



2. General Information

2.1 Equipment under Test (EUT) Description

EUT1	
Description:	CDMA 1X digital mobile phone
Model No.:	PXA20
Modulation:	CDMA1X
Frequency:	Tx: 824 MHz -849MHz; Rx: 869 MHz-894 MHz;
Serial No.:	N/A
Hardware Version:	466D CCB-S P3
Software Version:	CCBS_1.84.54T
EUT2	
Description:	Battery
Model No.:	ABN-1500A
Serial No.:	N/A
Manufacturer:	Shenzhen EPT Battery Co., Ltd.
Capacitance:	1500mAh
Rated Voltage:	3.6V
Charge Limit:	4.5V
EUT3	
Description:	AC Adapter (Charger for Battery)
Model No.:	DYS051-066080-7824B
Serial No.:	N/A
Manufacturer:	De-Yu Electronics Co., Ltd. Fuzhou
Rated Input:	~ 120-240V, 150mA Max 8 W, 63Hz
Rated Output:	≡ 6.6 V, 800mA, Max 5.28W
Length DC cable:	N/A

NOTE:

1. The EUT is a CDMA Cellular Wireless Phone operating in Cellular 800MHz band. And the device doesn't support TDSO and EVDO.
2. The normal configuration for the EUT is the CDMA Cellular Wireless Phone associated with ancillary equipments e.g. the Battery and/or the AC Adapter (Charger).
3. For detailed features about the EUT, please see user manual supplied by the applicant.



2.2 Test Standards and Results

The objective of the report is to perform tests according to 47 CFR Part 2, Part 22 for FCC ID Certification:

No.	Identity	Document Title
1	47 CFR Part 2 (10-1-05 Edition)	Frequency Allocations and Radio Treaty Matters; General Rules and Regulations
2	47 CFR Part 22 (10-1-05 Edition)	Public Mobile Services

Test detailed items and the results are as below:

No.	Rules	Test Type	Result	Date of Test
FCC Part 22 Requirement				
1	§2.106 §22.905	Frequencies	PASS	2009-12-1/15
2	§2.1046	Conducted RF Output Power at Antenna Terminal	PASS	2009-12-1/15
3	§2.1049 §22.917	Occupied Bandwidth	PASS	2009-12-2/15
4	§2.1051 §2.1057 §22.917	Band edge	PASS	2009-12-2/15
5	§2.1051 §2.1057 §22.917	Conducted Spurious Emission at Antenna Terminal	PASS	2009-12-2/15
6	§22.913	Transmitter Radiated Power (EIRP/ERP)	PASS	2009-12-3/15
7	§2.1053 §2.1057 §22.917	Radiated Spurious Emission	PASS	2009-12-4/15
8	§2.1055 §22.355	Frequency Stability	PASS	2009-12-4/15

2.3 Facilities and Accreditations

2.3.1 Facilities

Shenzhen Electronic Product Quality Testing Center (Morlab) is a testing organization accredited by China National Accreditation Board for Laboratories (CNAL) according to ISO/IEC 17025. The accreditation certificate number is L1659.

All measurement facilities used to collect the measurement data are located at Electronic Testing Building, Shahe Road, Xili, Nanshan District, Shenzhen, P. R. China. The site was constructed in conformance with the requirements of ANSI C63.7, ANSI C63.4 and CISPR Publication 22, the FCC registration number is 741109.

2.3.2 Test Equipments

Description	Manufacturer	Model	Serial No.	Cal. Date	Cal. Due
System Simulator	Rohde&Schwarz	CMU200	105571	2009.11	1year
System Simulator	Anritsu	MT8820A	BE07218	2009.10	1year
Spectrum Analyzer	Rohde&Schwarz	FSP30	101020	2009.11	1year
Power Splitter	Weinschel	1506A	NW521	(n.a.)	(n.a.)
Attenuator 1	Resnet	20dB	(n.a.)	(n.a.)	(n.a.)
Attenuator 2	Resnet	3dB	(n.a.)	(n.a.)	(n.a.)

NOTE:

Equipments listed above have been calibrated and are in the period of validation.

2.3.3 Test Environment Conditions

During the measurement, the environmental conditions were within the listed ranges:

Temperature:	20 - 25°C
Relative Humidity:	40 - 50%
Atmospheric Pressure:	96kPa

2.4 47 CFR Part 2, Part 22H Requirements

2.4.1 Conducted Related Tests

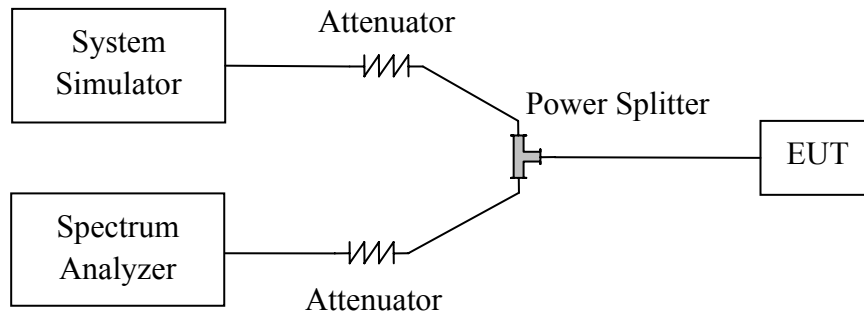

1. The EUT is coupled to the Spectrum Analyzer and the System Simulator with the suitable Attenuators through the Power Splitter; the path loss is calibrated to correct the reading.
2. The EUT is configured here as EUT + Battery + Charger.
3. The EUT is commanded via the System Simulator (SS) to operate at the maximum output power. A communication link is established between the EUT and the SS.
4. The Spectrum Analyzer is set to max-peak detector function and maximum hold mode.

2.4.2 Radiated Power and Spurious Emission Tests

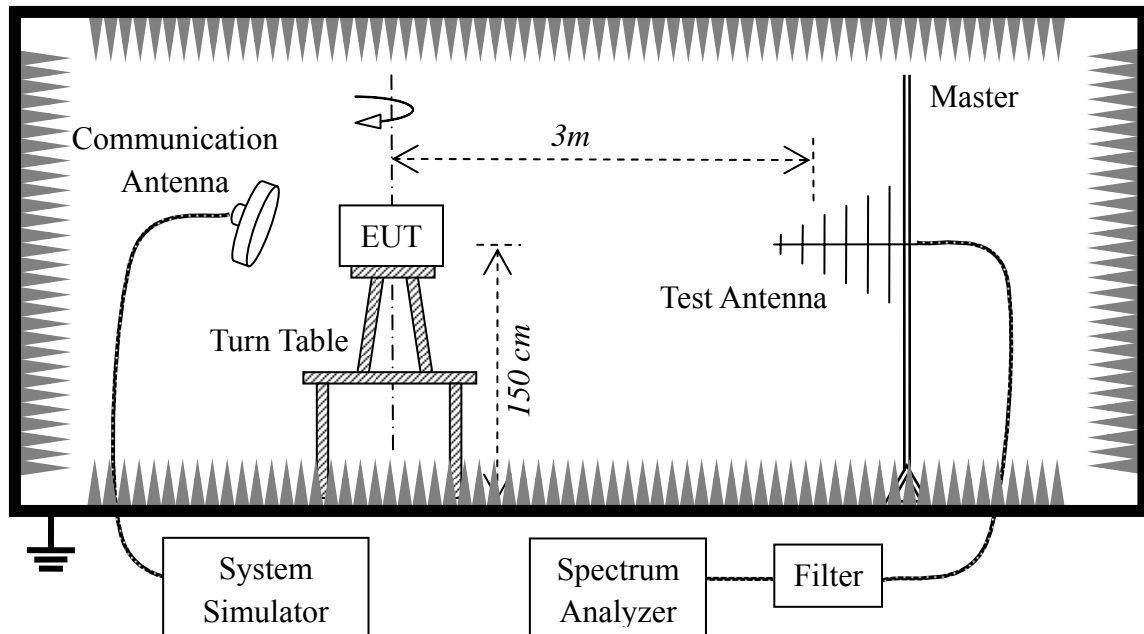

1. The test is performed in a full-Anechoic Chamber; the air loss of the site and the factors of the test system are pre-calibrated using the substitution method.
2. The EUT is configured as EUT + Battery + Charger.
3. The EUT is placed on the vertical axis of a Turn Table 1.5 meters above the ground.
4. The Test Antenna is a bi-log one or a horn one, and the Test Antenna is at the same height as the EUT.
5. The EUT is commanded via the System Simulator (SS) to operate at the maximum output power. A communication link is established between the EUT and the SS.
6. The Spectrum Analyzer is set to max-peak detector function and maximum hold mode.

2.4.3 Frequency Stability Test

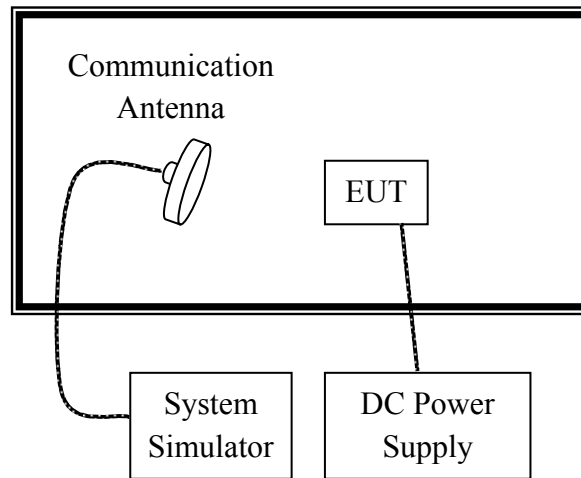

1. The test is performed in a Temperature Chamber.
2. The EUT is configured as MS + DC Power Supply.

2.5 Frequencies

2.5.1 Requirement

According to FCC §22.905, the frequencies blocks assignment for the Cellular Radiotelephone Service are listed as below.

- (a) Channel Block A:
 - Mobile 824 - 835MHz, Base 869 - 880MHz;
 - Mobile 845 - 846.5MHz, Base 890 - 891.5MHz
- (b) Channel Block B:
 - Mobile 835 - 845 MHz, Base 880 - 890MHz;
 - Mobile 846.5 - 849 MHz, Base 891.5 - 894MHz

2.5.2 Procedure

1. Perform test system setup as section 2.4.1.
2. The resolution bandwidth (RBW) of the Spectrum Analyzer was set to at least 1% of the emission bandwidth of the fundamental emission of the transmitter, e.g. for GSM modulated signal (here used): $RBW=VBW=3\text{kHz}$, for CDMA modulated signal: $RBW=VBW=30\text{kHz}$.
3. The lowest and the highest channel were selected to perform tests respectively. Channel No.1013(lowest) and 777(highest) for cellular band;
4. The MS operated at the maximum output power. Set the Spectrum Analyzer suitably to capture the waveform, search peak and mark, and then record the plot.

2.5.3 Test modes

Test status	Channel	Test plot
SO2 RC1/REV1	1013(Low)	1
	777(High)	2
SO2 RC3/REV3	1013(Low)	3
	777(High)	4
SO55 RC1/REV1	1013(Low)	5
	777(High)	6
SO55 RC3/REV3	1013(Low)	7
	777(High)	8

Note: The frequencies of the lowest channel and the highest channel are as the following figures.

2.5.4 Test result

1. CDMA MODE (SO2 RC1/REV1 1013 CH.)

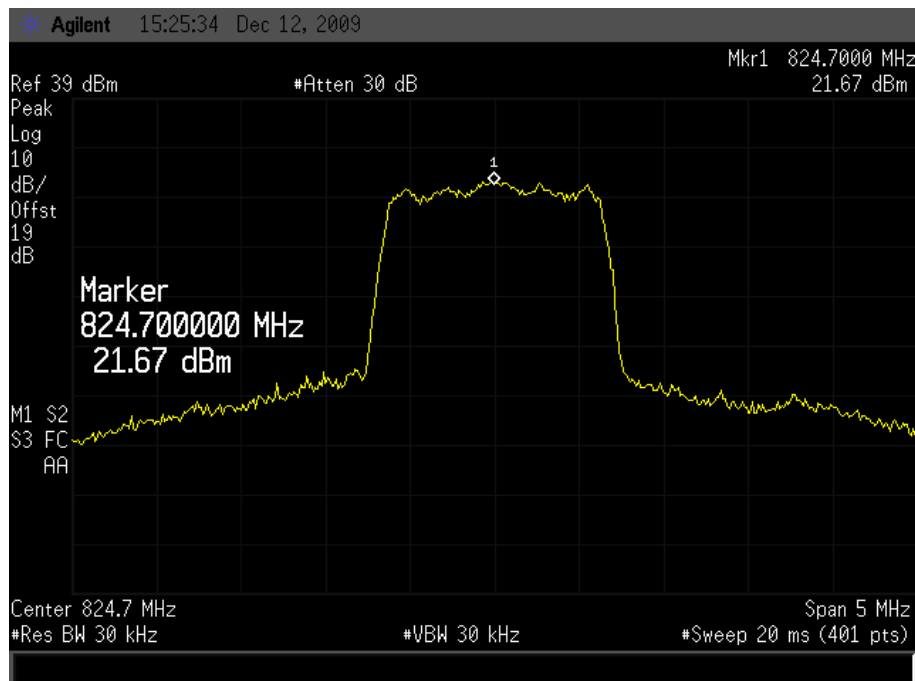

2. CDMA MODE (SO2 RC1/REV1 777 CH.)

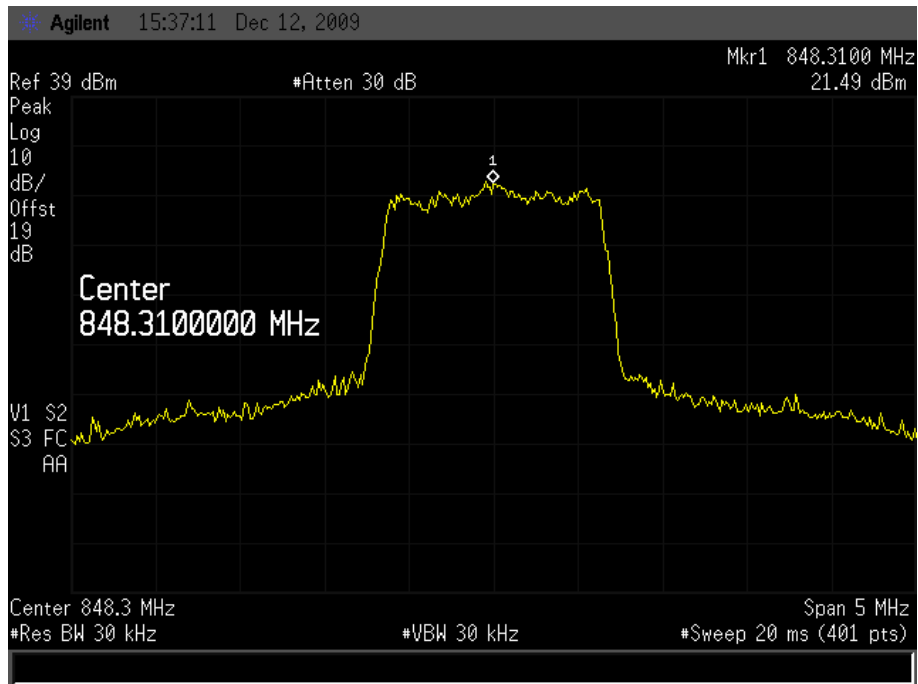

3. CDMA MODE (SO2 RC3/REV3 1013 CH.)

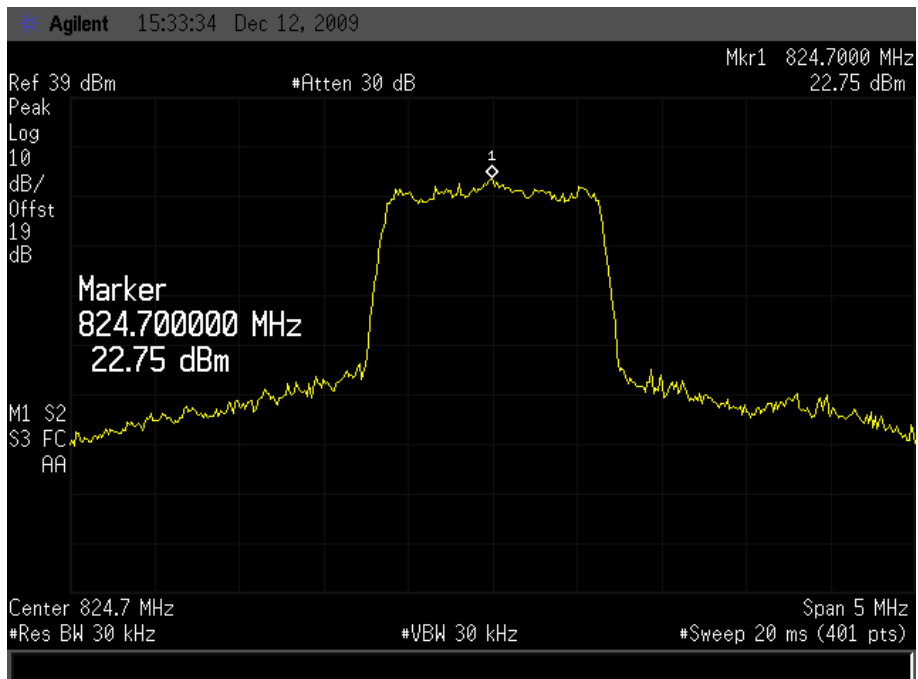

4. CDMA MODE (SO2 RC3/REV3 777 CH.)

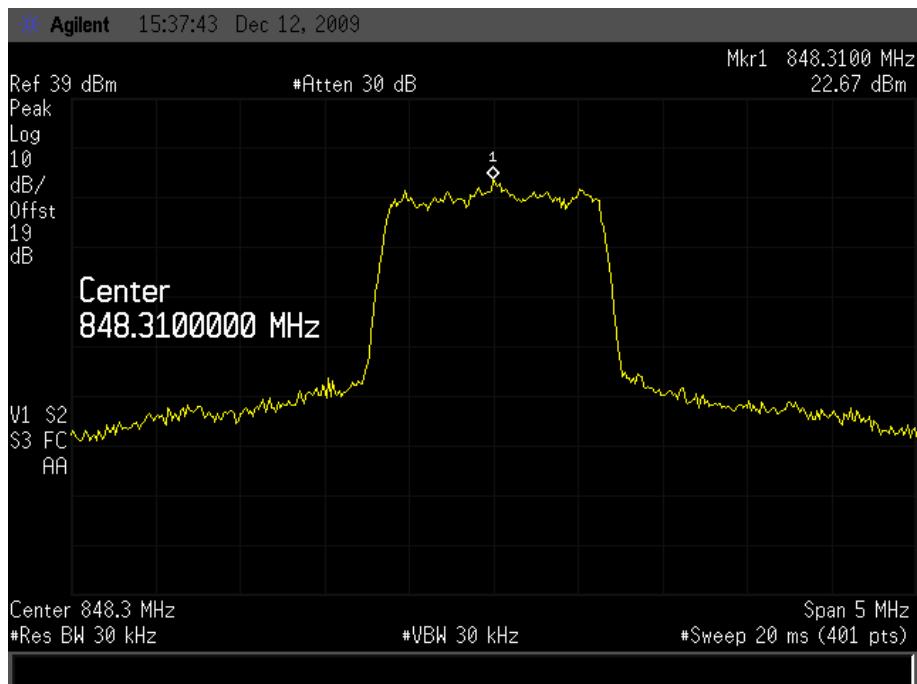

5. CDMA MODE (SO55 RC1/REV1 1013 CH.)

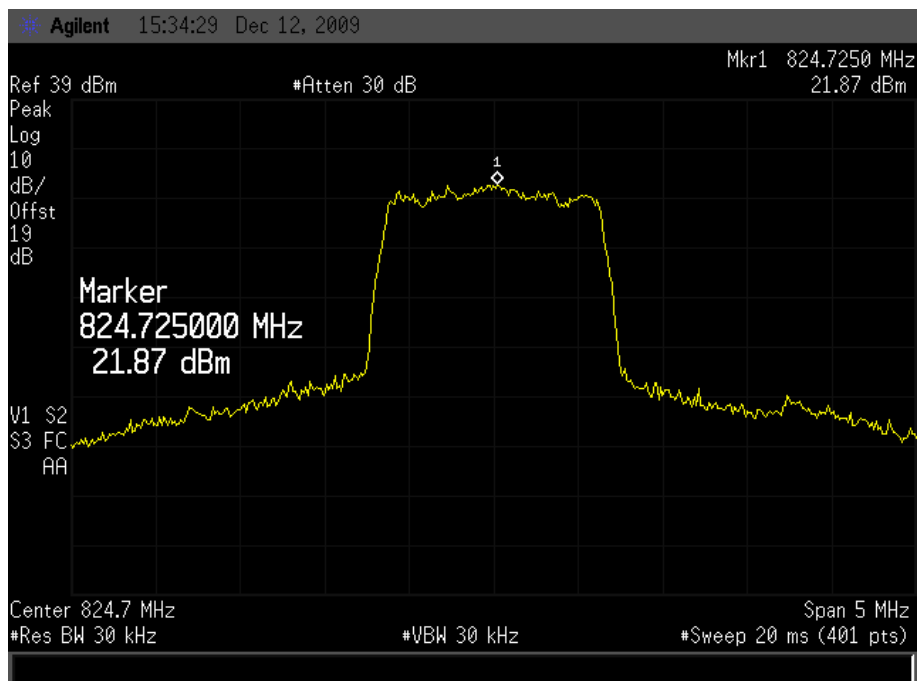

6. CDMA MODE (SO55 RC1/REV1 777CH.)

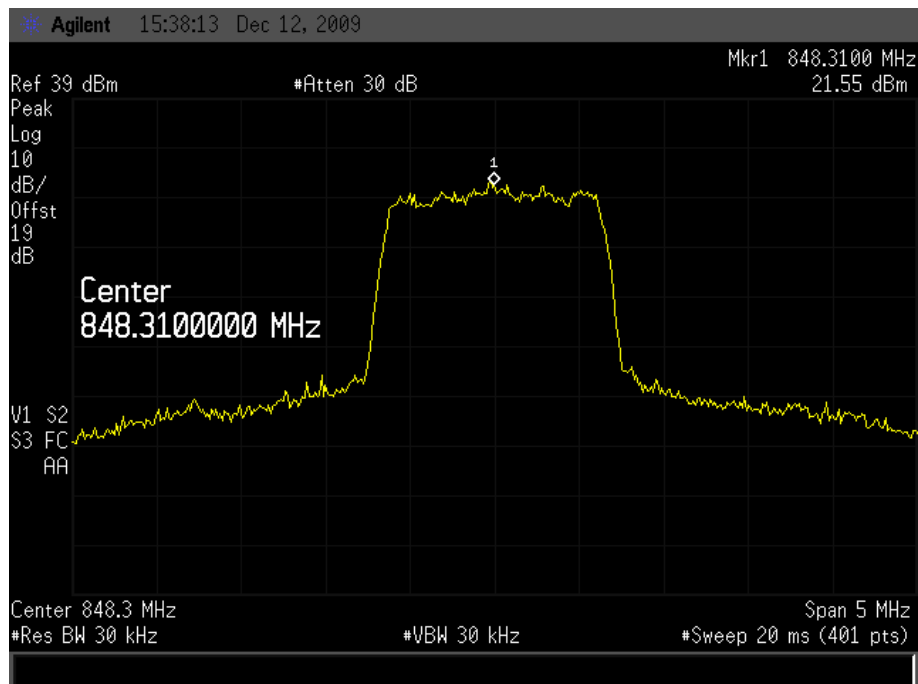

7. CDMA MODE (SO55 RC3/REV3 1013 CH.)

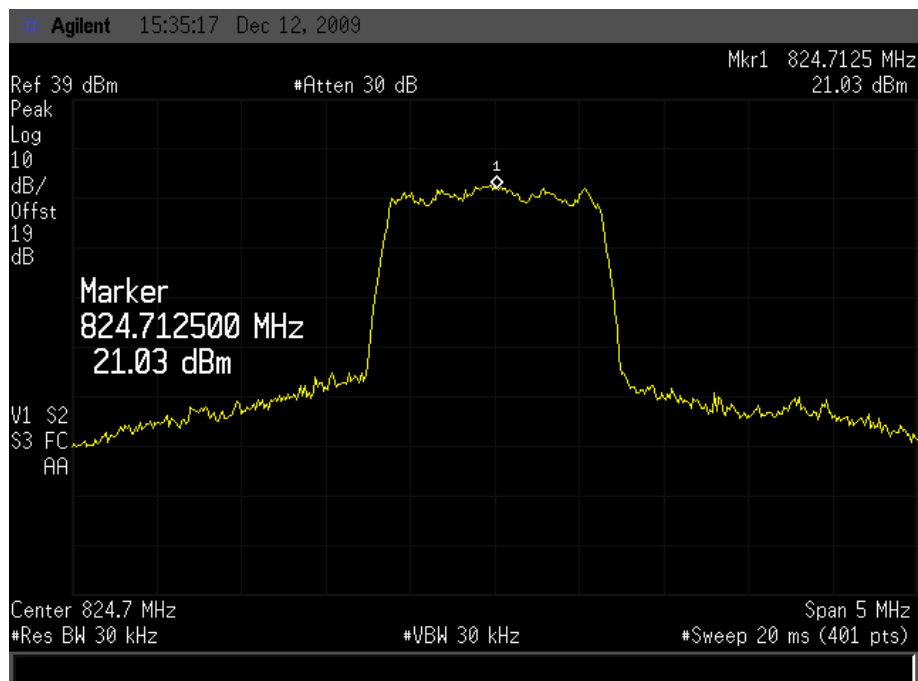

8. CDMA MODE (SO55 RC3/REV3 777 CH.)

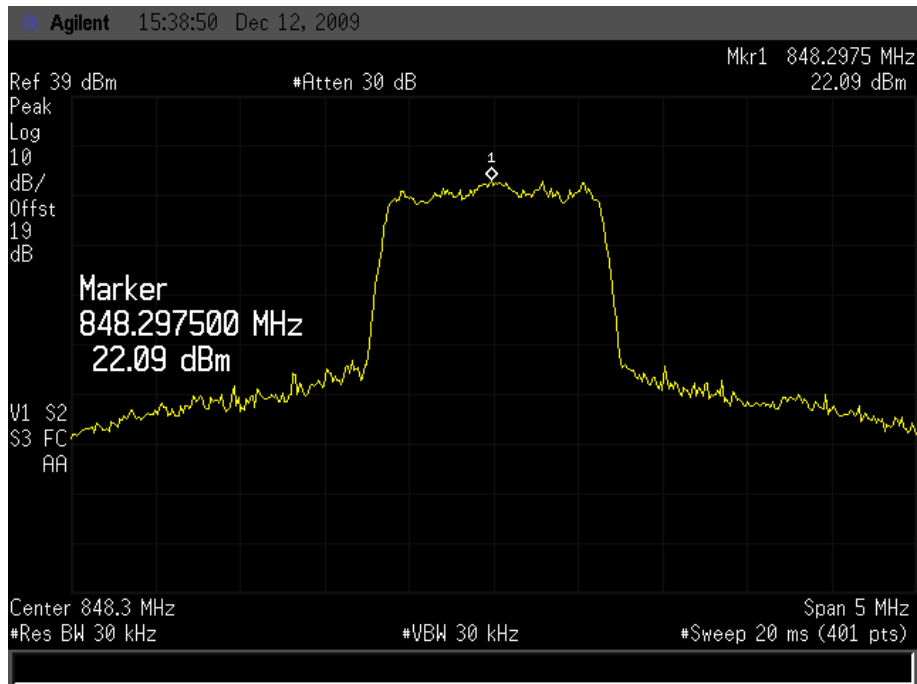

2.6 Conducted RF Output Power

2.6.1 Requirement

According to FCC §2.1046 (a), for transmitters other than single sideband, independent sideband and controlled carrier radiotelephone, power output shall be measured at the RF output terminals when the transmitter is adjusted in accordance with the tune-up procedure to give the values of current and voltage on the circuit elements specified in §2.1033 (c)(8). The electrical characteristics of the radio frequency load attached to the output terminals when this test is made shall be stated.

2.6.2 Test Procedure

1. Perform test system setup as section 2.4.1 (the radio frequency load attached to the EUT antenna terminal is 50Ω).
2. The resolution bandwidth of the Spectrum Analyzer is set to be comparable to the emission bandwidth of the transmitter, e.g. for GSM modulated signal (here used): RBW=VBW=1MHz, for CDMA modulated signal: RBW=VBW=3MHz.
3. The lowest and the highest channel were selected to perform tests respectively. Channel No.1013(lowest) 384(middle)and 777(highest) for cellular band;
4. Set the frequency range of the Spectrum Analyzer suitably to capture the waveform; search peak and mark it; finally record the peak and the plot.

2.6.3 Test Result

Test status	Channel	Frequency (MHz)	Measured Power		Rated Power		Test plot.
			dBm	W	dBm	W	
SO2 RC1/REV1	1013(Low)	824.69	30.43	1.104	33	7	1
	384(Mid)	836.77	30.22	1.052	33	7	2
	777(High)	848.58	30.11	1.026	33	7	3
SO2 RC3/REV3	1013(Low)	824.69	29.86	0.968	33	7	4
	384(Mid)	836.90	29.31	0.853	33	7	5
	777(High)	848.45	29.75	0.944	33	7	6
SO55 RC1/REV1	1013(Low)	824.56	29.87	0.971	33	7	7
	384(Mid)	836.50	29.62	0.916	33	7	8
	777(High)	848.71	29.54	0.899	33	7	9
SO55 RC3/REV3	1013(Low)	824.96	30.02	1.005	33	7	10
	384(Mid)	836.64	29.64	0.920	33	7	11
	777(High)	848.32	29.48	0.887	33	7	12

1 CDMA MODE (SO2 RC1/REV1 1013 CH.)

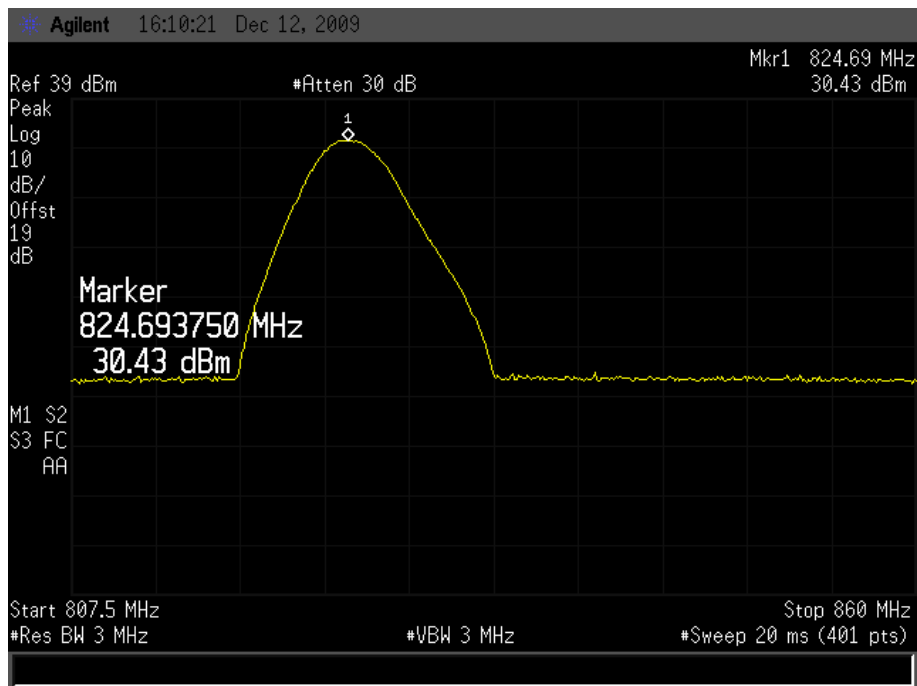

2 CDMA MODE (SO2 RC1/REV1 384 CH.)

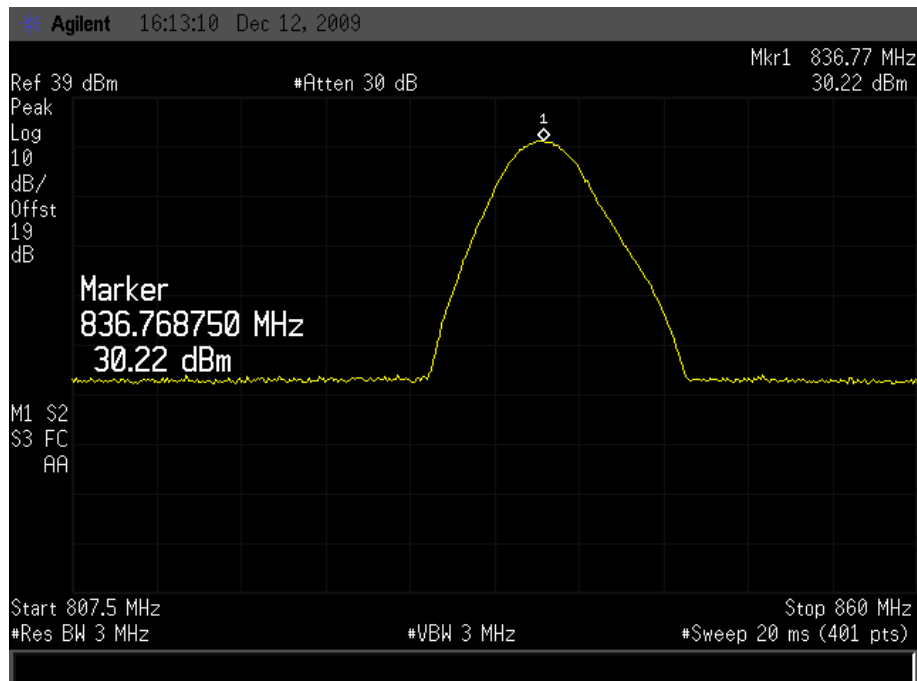

3 CDMA MODE (SO2 RC1/REV1 777 CH.)

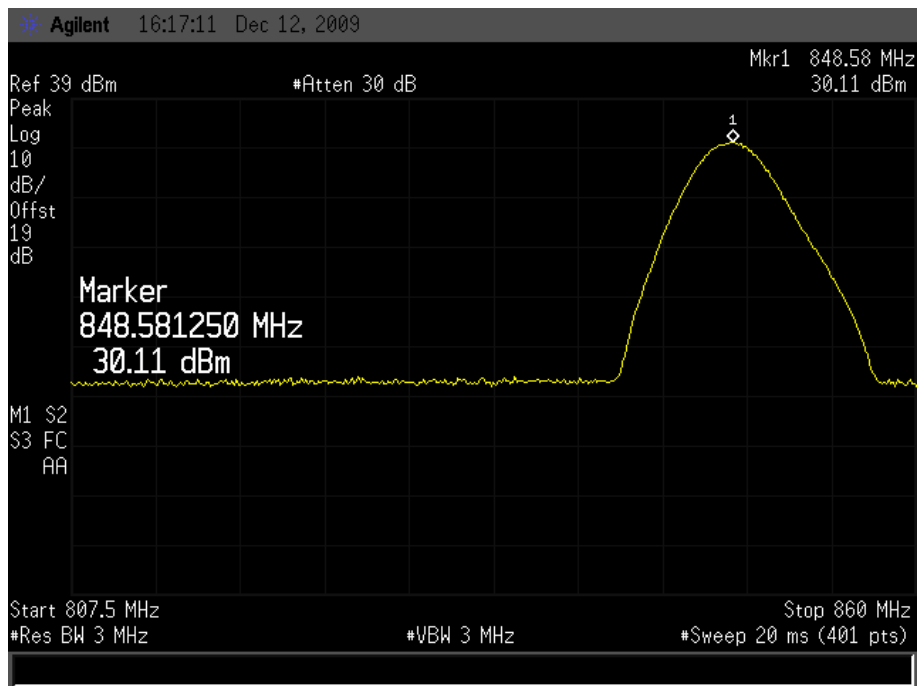

4 CDMA MODE (SO2 RC3/REV3 1013 CH.)

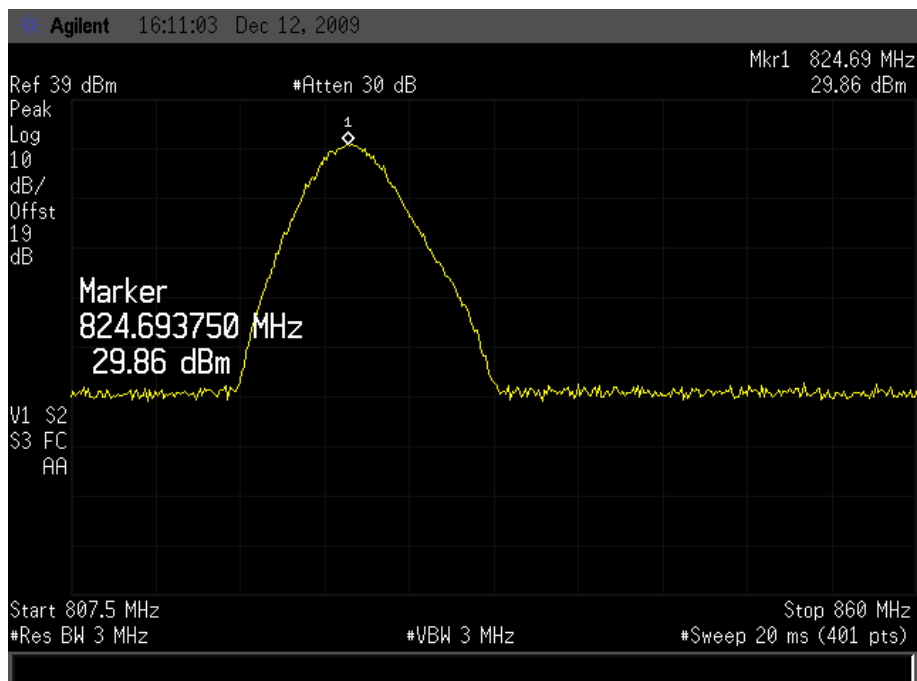

5 CDMA MODE (SO2 RC3/REV3 384 CH.)

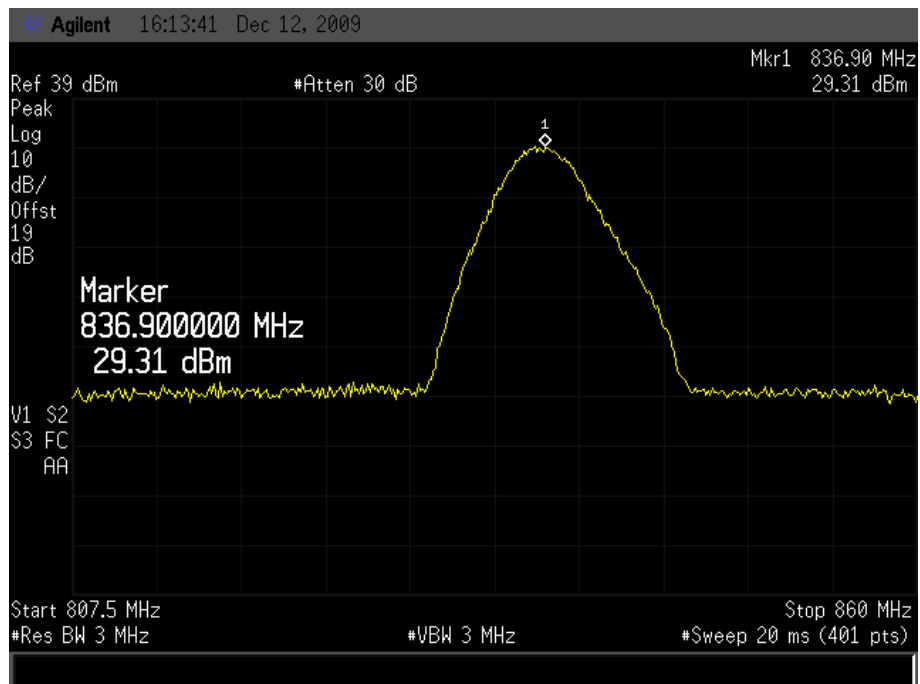

6 CDMA MODE (SO2 RC3/REV3 777 CH.)

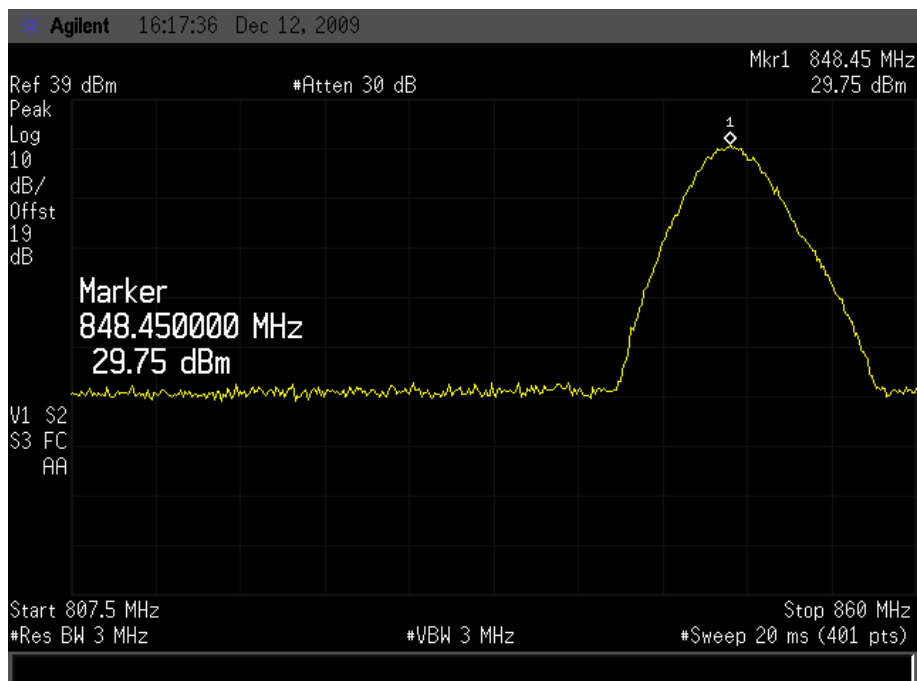

7 CDMA MODE (SO55 RC1/REV1 1013 CH.)

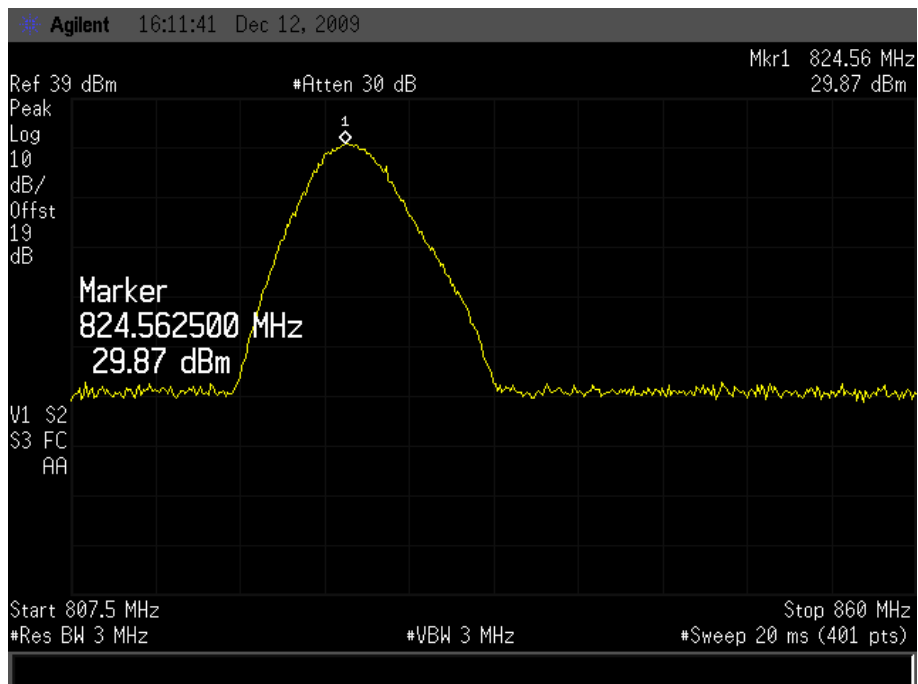

8 CDMA MODE (SO55 RC1/REV1 384 CH.)

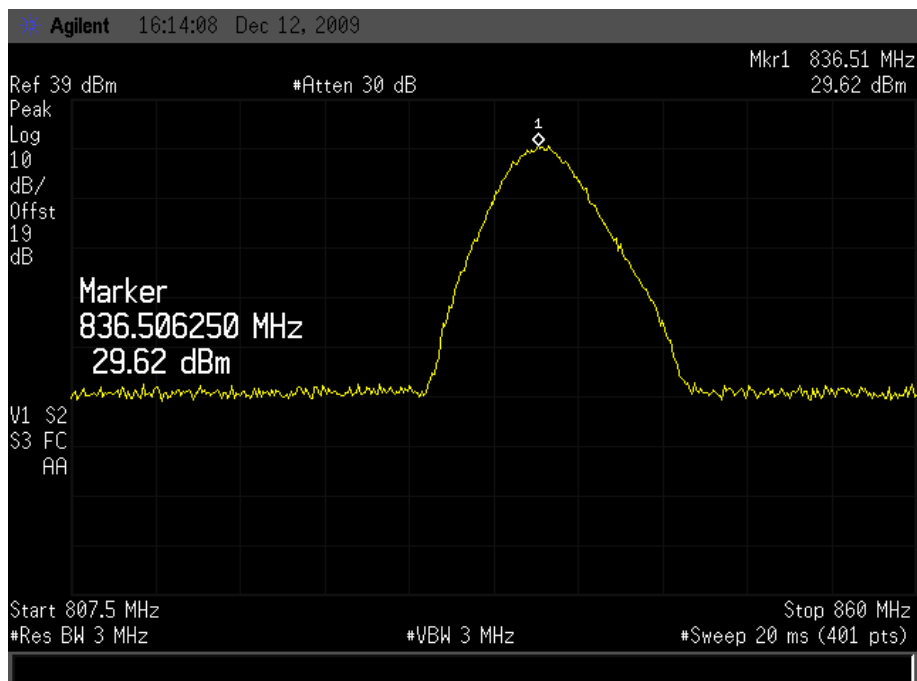

9 CDMA MODE (SO55 RC1/REV1 777CH.)

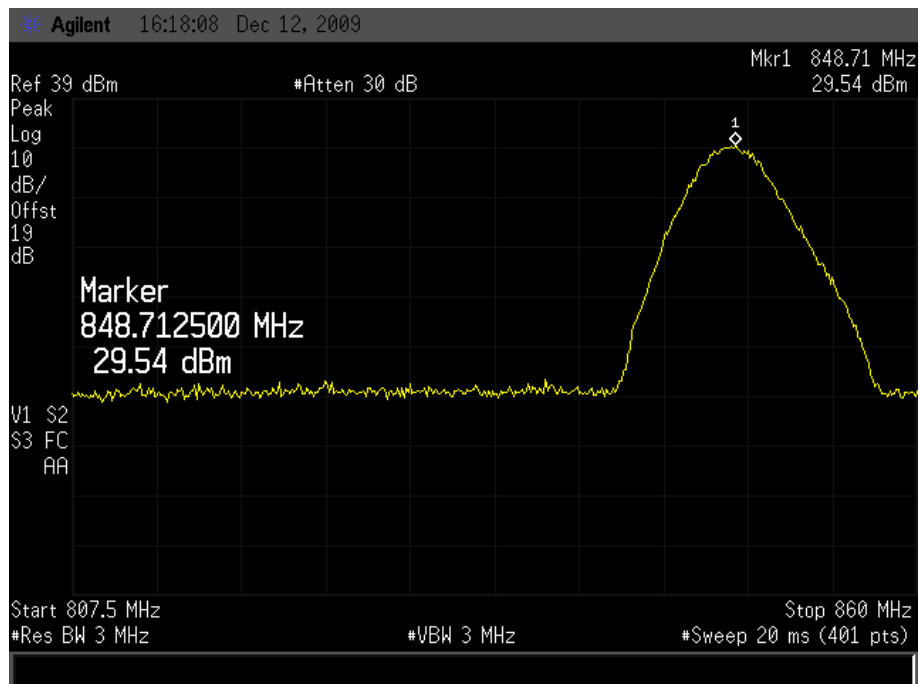

10 CDMA MODE (SO55 RC3/REV3 1013 CH.)

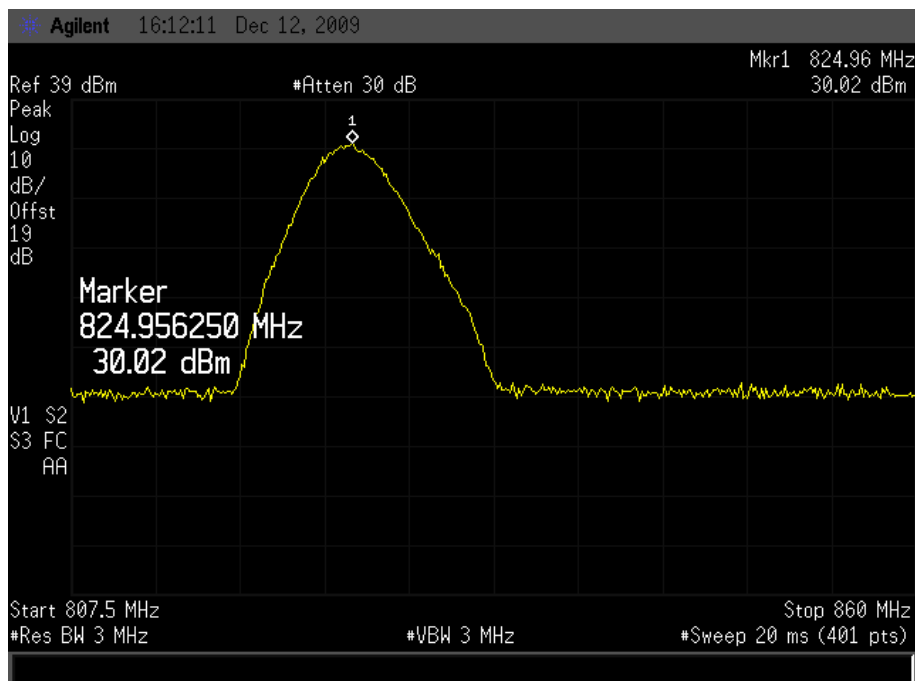

11 CDMA MODE (SO55 RC3/REV3 384 CH.)

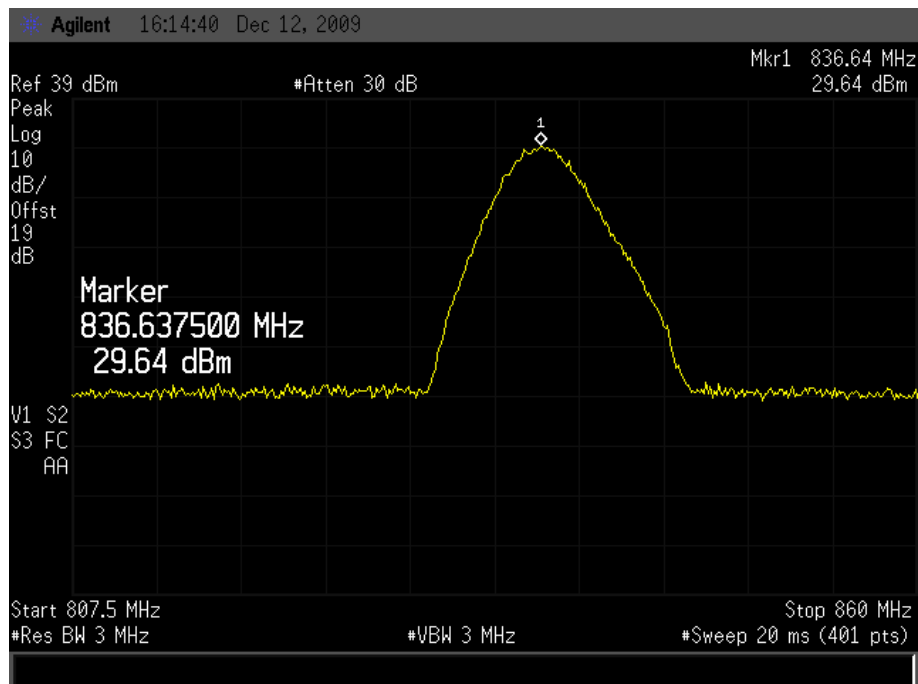

12 CDMA MODE (SO55 RC3/REV3 777 CH.)

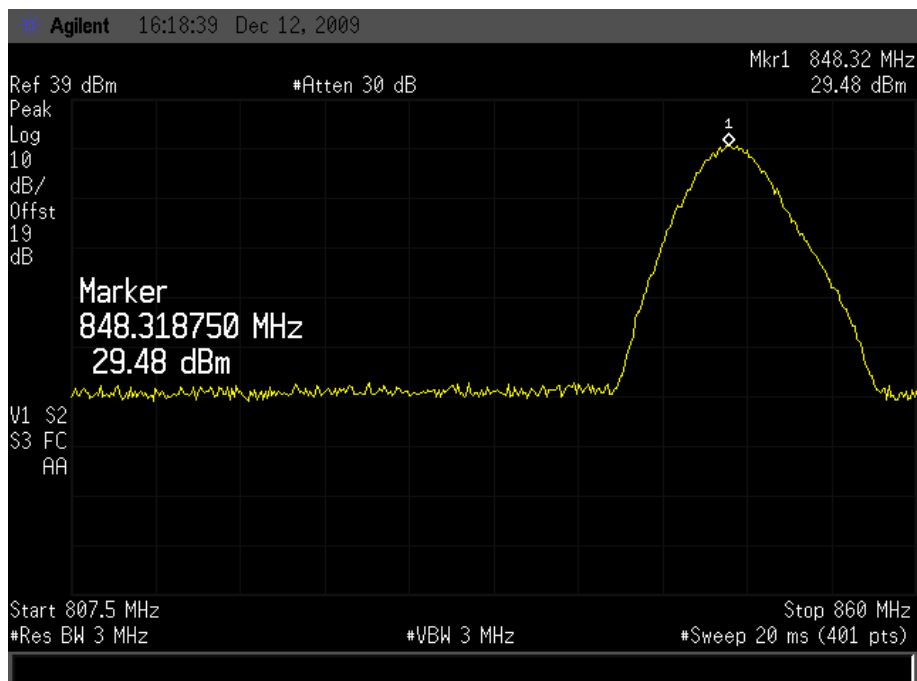

2.7 Occupied Bandwidth

2.7.1 Occupied Bandwidth Definition

According to FCC §2.1049, the occupied bandwidth is the frequency bandwidth such that, below its lower and above its upper frequency limits, the mean powers radiated are each equal to 0.5 percent of the total mean power radiated by a given emission.

Occupied bandwidth is also known as the 99% emission bandwidth. The emission bandwidth is defined as the width of the signal between two points, one below the carrier center frequency and one above the carrier center frequency, outside of which all emissions are attenuated at least 26dB below the transmitter power.

2.7.2 Test Procedure

- 1 Perform test system setup as section 2.4.1 (the radio frequency load attached to the EUT antenna terminal is 50Ω).
- 2 The resolution bandwidth of the Spectrum Analyzer is set to be comparable to the emission bandwidth of the transmitter, for CDMA modulated signal: $RBW=VBW=30\text{KHz}$.
- 3 The lowest and the highest channel were selected to perform tests respectively. Channel No.1013(lowest) 384(middle)and 777(highest) for cellular band;.
- 4 Set the frequency range of the Spectrum Analyzer suitably to capture the waveform; search peak and mark it; finally record the peak and the plot.

2.7.3 Test Result

Test status	Channel	Measured Occupied Bandwidth (MHz)	Test result	Test plot
SO2 RC1/REV1	1013(Low)	1.2725	PASS	1
	384(Mid)	1.2679	PASS	2
	777(High)	1.2848	PASS	3
SO2 RC3/REV3	1013(Low)	1.2724	PASS	4
	384(Mid)	1.2688	PASS	5
	777(High)	1.2710	PASS	6
SO55 RC1/REV1	1013(Low)	1.2723	PASS	7
	384(Mid)	1.2665	PASS	8
	777(High)	1.2669	PASS	9
SO55 RC3/REV3	1013(Low)	1.2682	PASS	10
	384(Mid)	1.2733	PASS	11
	777(High)	1.2780	PASS	12

1 CDMA MODE (SO2 RC1/REV1 1013 CH.)

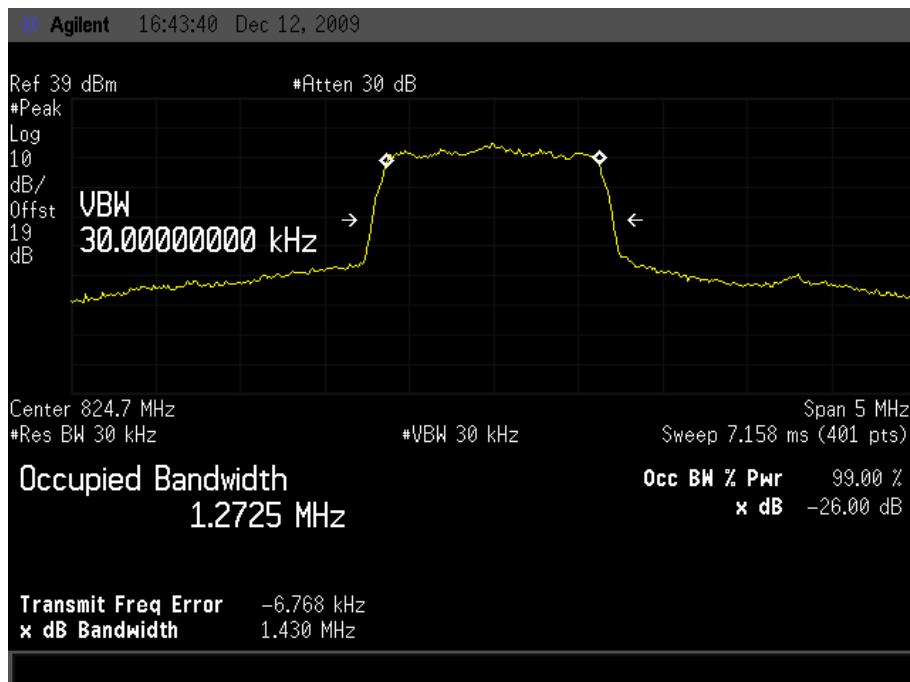

2 CDMA MODE (SO2 RC1/REV1 384 CH.)

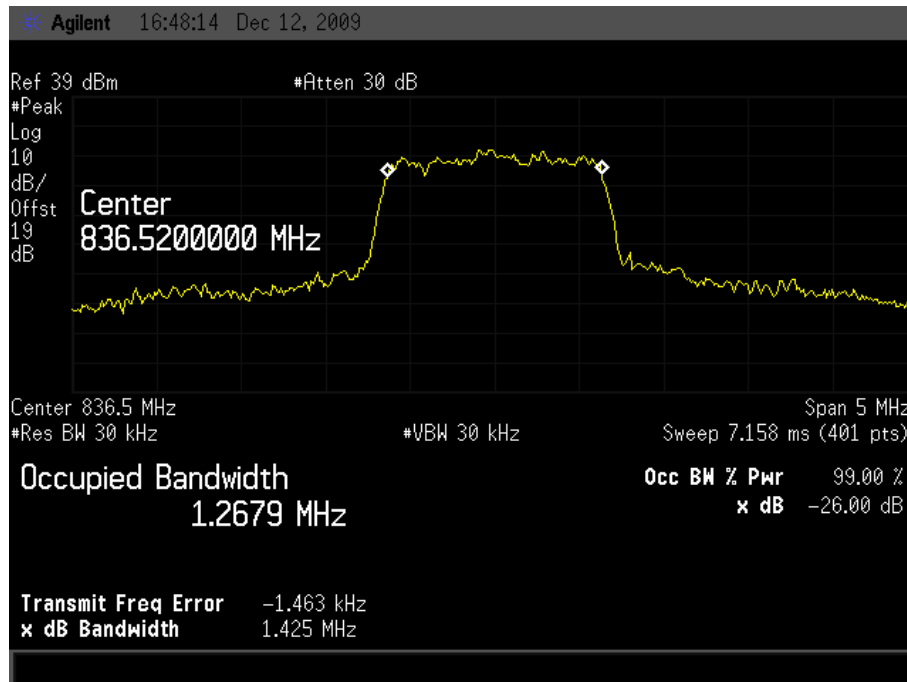

3 CDMA MODE (SO2 RC1/REV1 777 CH.)

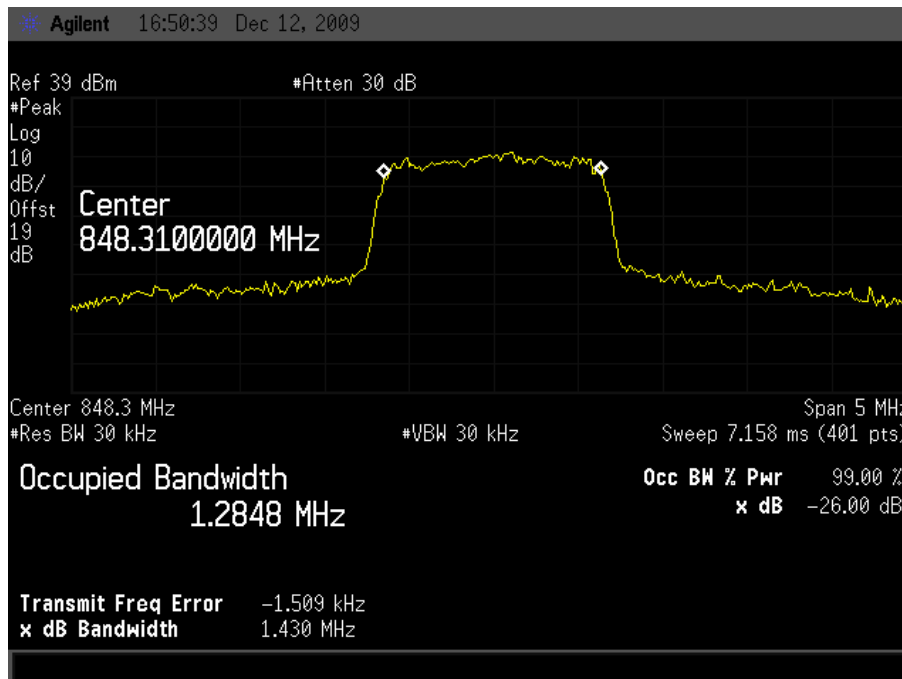

4 CDMA MODE (SO2 RC3/REV3 1013 CH.)

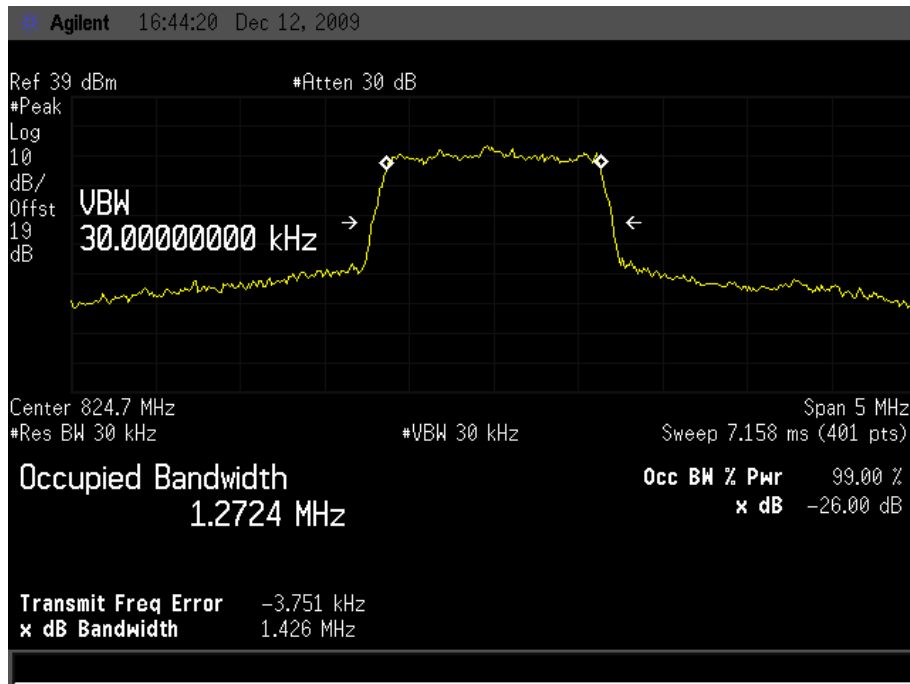

5 CDMA MODE (SO2 RC3/REV3 384 CH.)

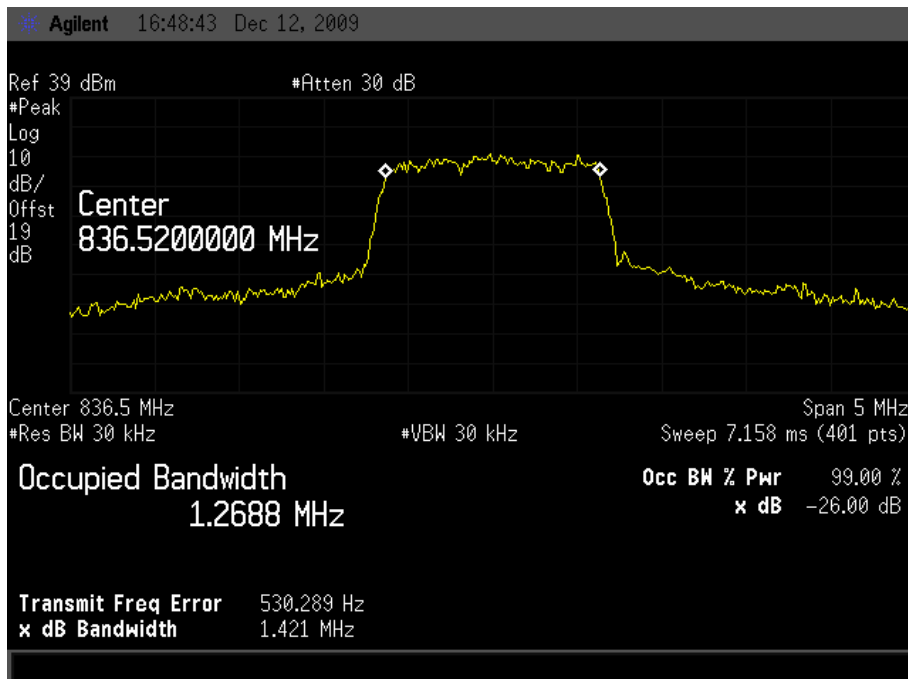

6 CDMA MODE (SO2 RC3/REV3 777 CH.)

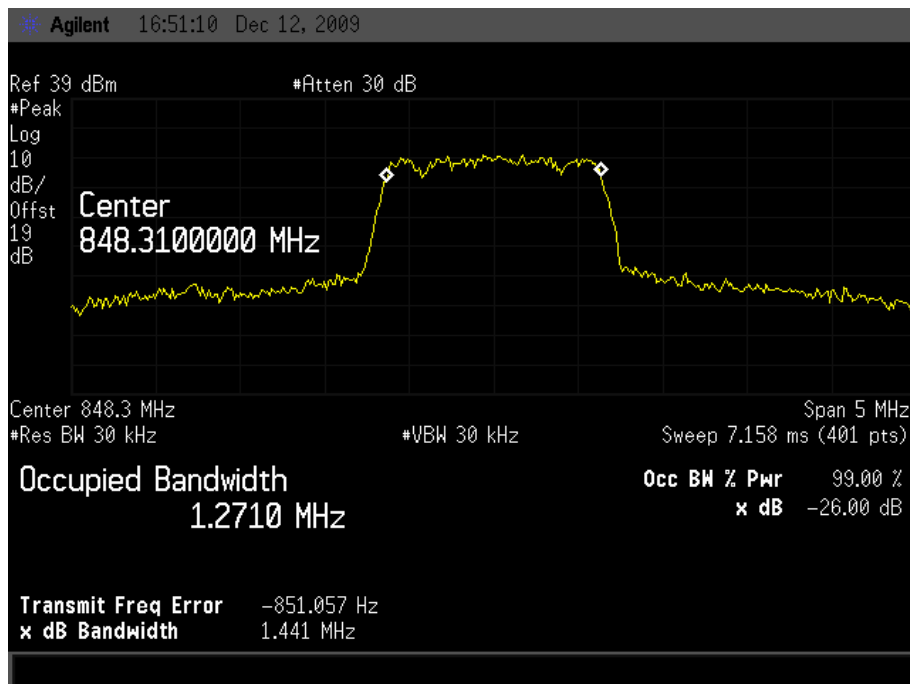

7 CDMA MODE (SO55 RC1/REV1 1013 CH.)

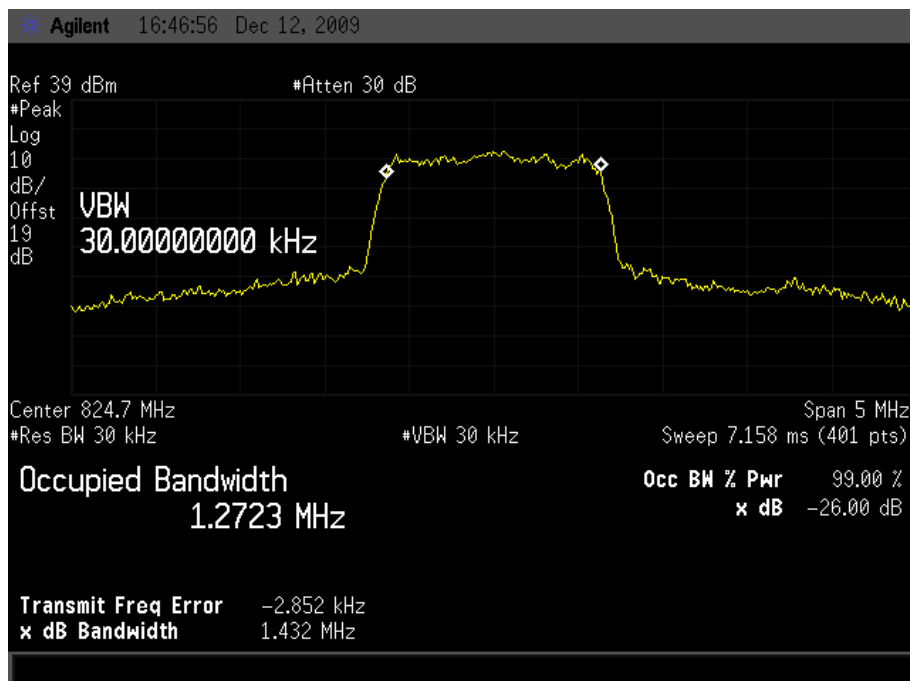

8 CDMA MODE (SO55 RC1/REV1 384 CH.)

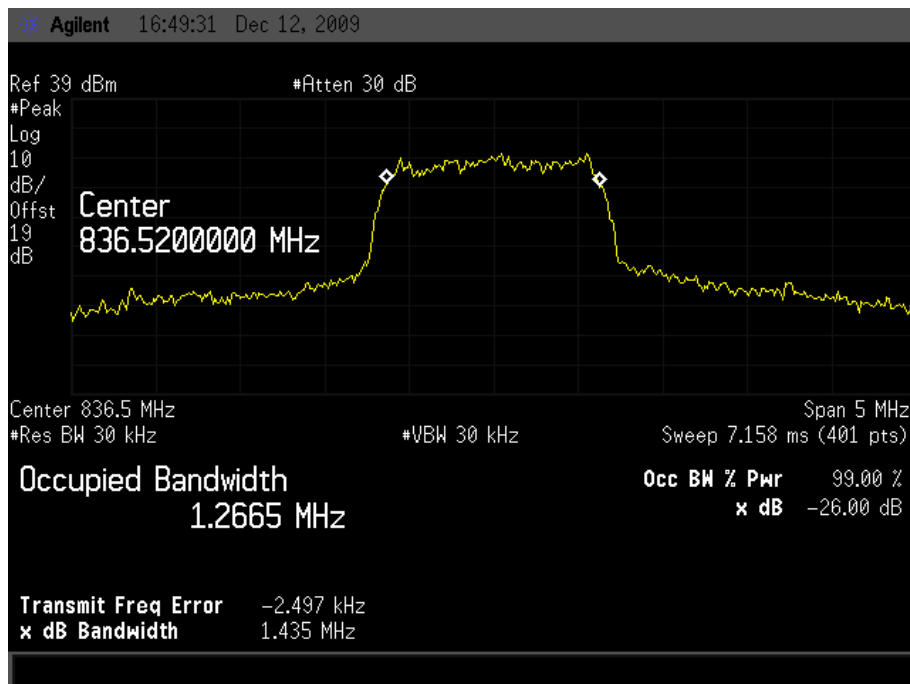

9 CDMA MODE (SO55 RC1/REV1 777CH.)

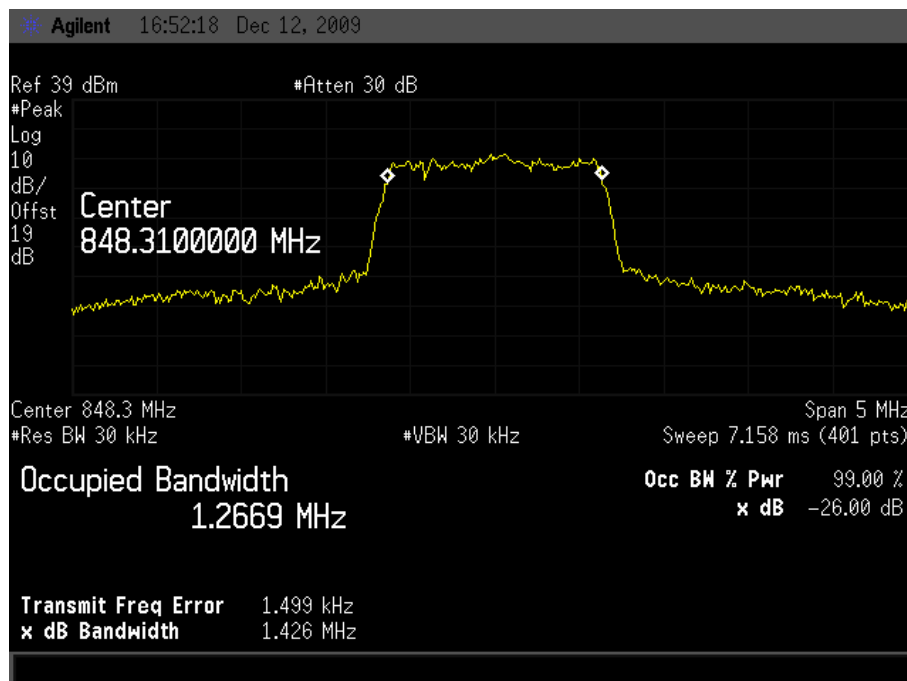

10 CDMA MODE (SO55 RC3/REV3 1013 CH.)

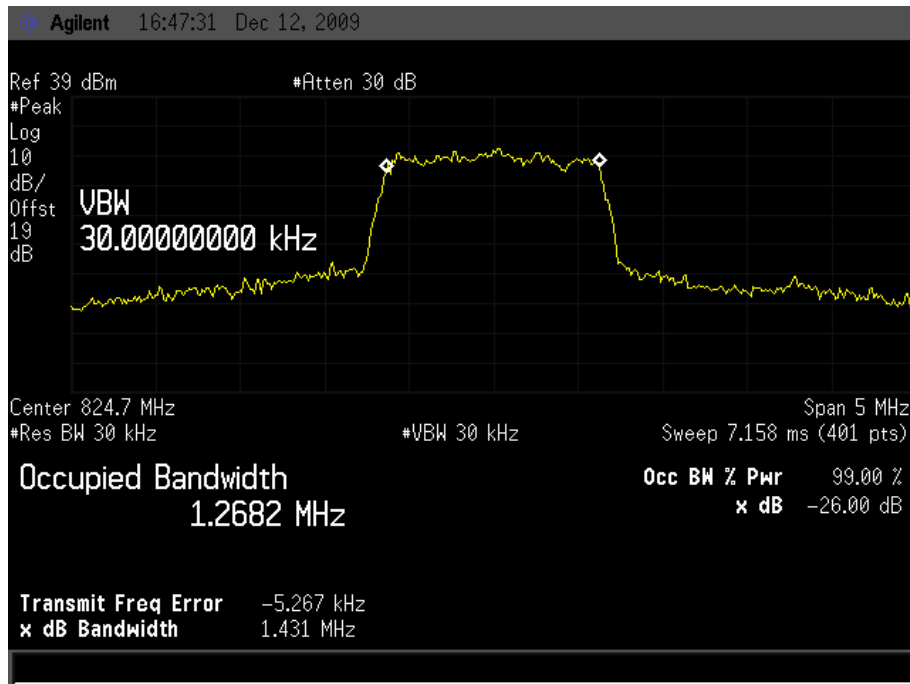

11 CDMA MODE (SO55 RC3/REV3 384 CH.)

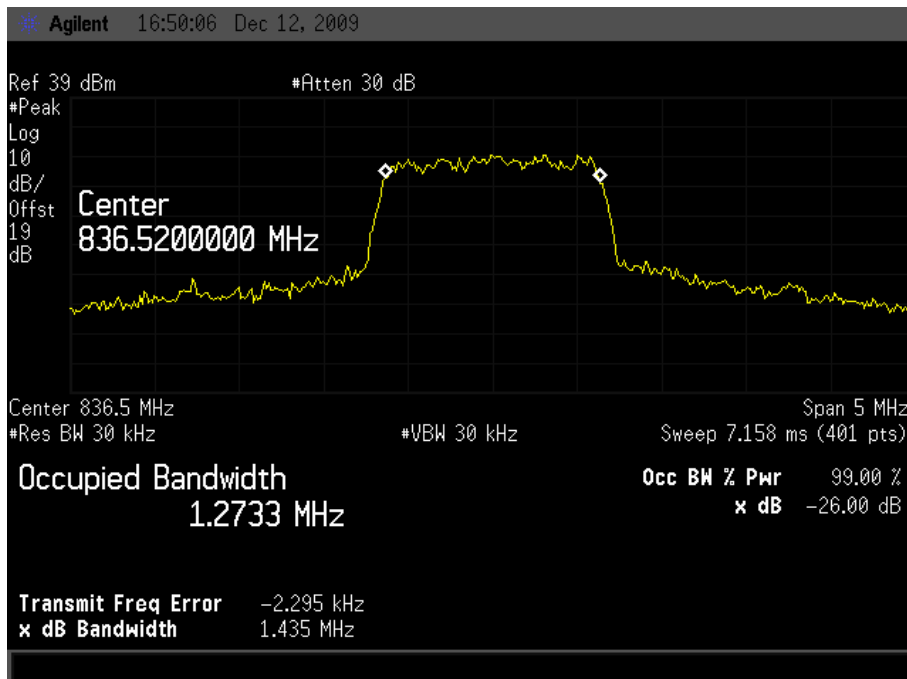

12 CDMA MODE (SO55 RC3/REV3 777 CH.)

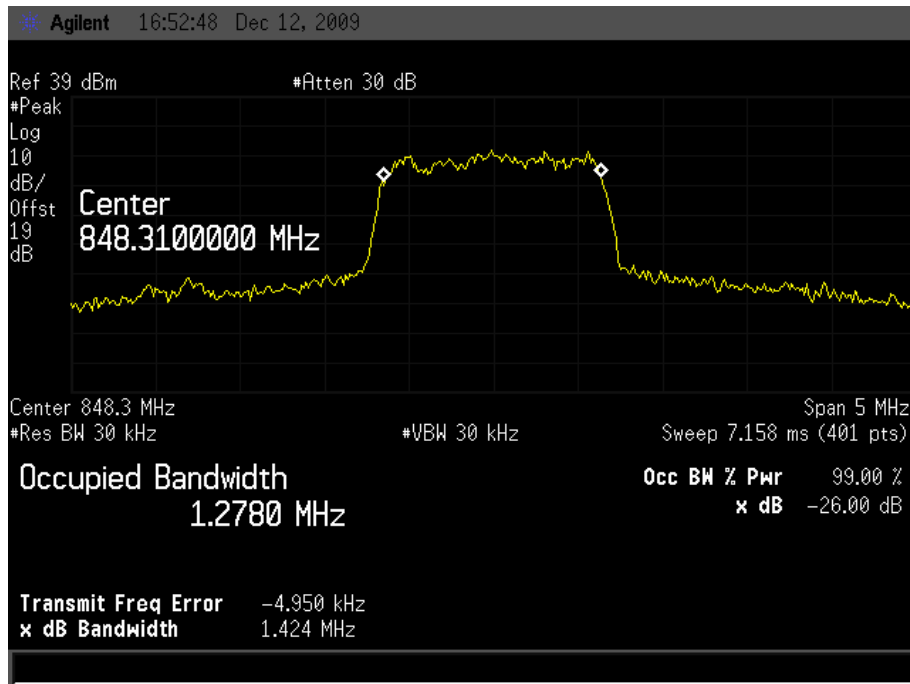

2.8 Plot for Band-edge

2.8.1 Test modes

Test status	Channel	Measured Band-edge(MHz)	Test result
SO2 RC1/REV1	1013(Low)	824	PASS
	777(High)	849	PASS
SO2 RC3/REV3	1013(Low)	824	PASS
	777(High)	849	PASS
SO55 RC1/REV1	1013(Low)	824	PASS
	777(High)	849	PASS
SO55 RC3/REV3	1013(Low)	824	PASS
	777(High)	849	PASS



Note: The Band-edge of the lowest channel and the highest channel are as the following figures.
The worst case(SO55 RC1/REV1)only recorded in this report.

2.8.2 Test result

1 CDMA MODE (SO55 RC1/REV1 1013 CH.)

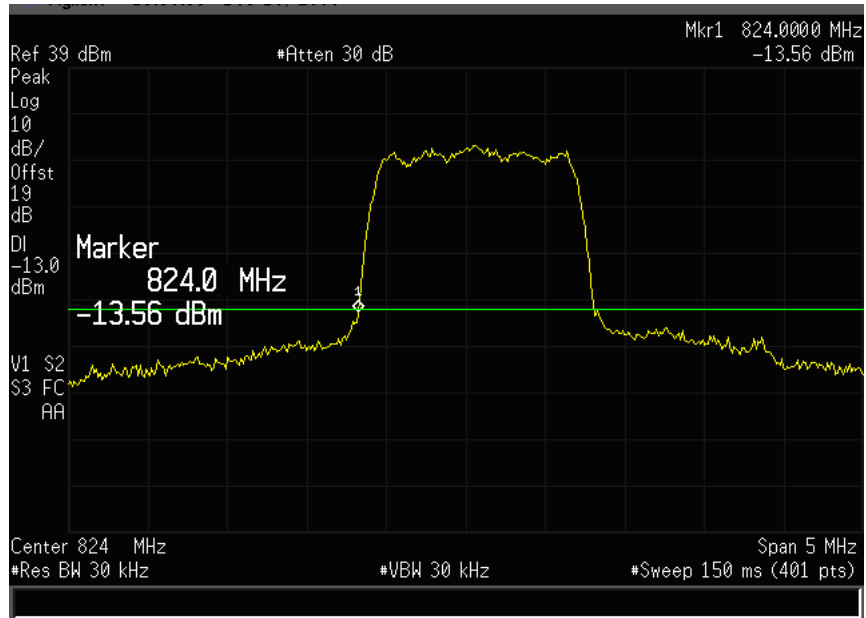

2 CDMA MODE (SO55 RC1/REV1 777 CH.)

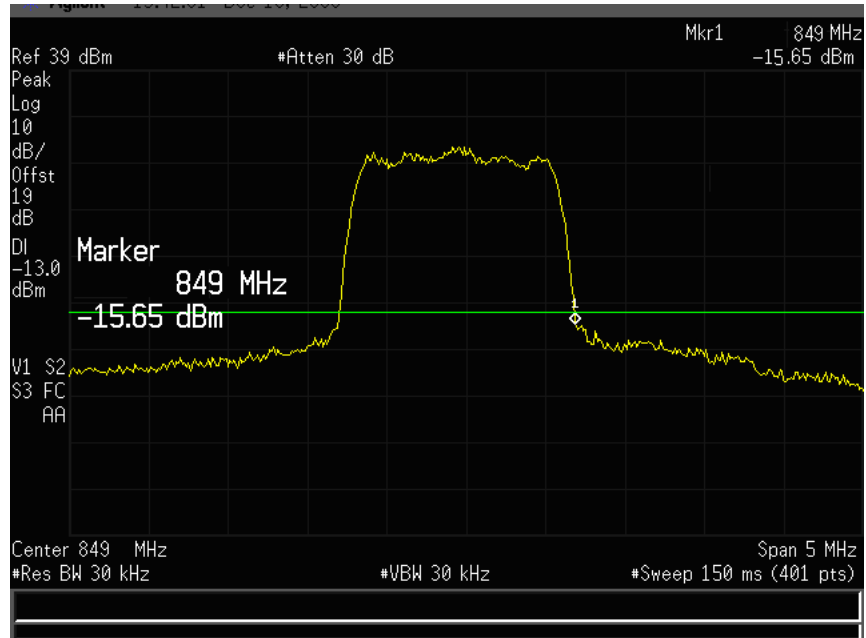



The setting of spectrum analyzer
Center frequency in CH1013 is 824M
Center frequency in CH777 is 849M
RBW=VBW=30kHz,SPAN=5MHz

2.9 Conducted Spurious Emission

2.9.1 Requirement

According to FCC §22.917(a) and §24.238(a), the power of any emission outside of the authorized operating frequency ranges must be attenuated below the transmitting power (P) by a factor of at least $43+10*\log(P)$ dB. This calculated to be -13dBm.

According to FCC §22.917 (b) and §24.238(b), in the 1MHz bands immediately outside and adjacent to the frequency block a resolution bandwidth of at least one percent of the emission bandwidth of the fundamental emission of the transmitter may be employed. Thus the 26dB emission bandwidth is measurement for showing compliance at the band-edge.

2.9.2 Test Procedure

1. Perform test system setup as section 2.4.1.
2. Make a limit line whose value is -13dBm on the Spectrum Analyzer.
3. The lowest and the highest channel were selected to perform tests respectively. Channel No.1013(lowest) 384(middle)and 777(highest) for cellular band;
4. Set the RBW of the Spectrum Analyzer to 1MHz, and the measuring frequency range from 9kHz to 1^{0th} harmonic of the fundamental frequency (here used 26.5GHz); mark the fundamental frequency and the harmonics thereof; finally record the harmonics and the plot. Note, the measuring frequency range can be divided into several parts to perform tests.
5. In the 1MHz bands immediately outside and adjacent to the frequency black, the RBW of the Spectrum Analyzer was set to at least one percent of the emission bandwidth of the fundamental emission of the transmitter, e.g. for GSM modulated signal (here used): RBW=3kHz, for CDMA modulated signal: RBW=1MHz.
6. Set the frequency range of the Spectrum Analyzer suitably to capture the waveform; search peak and mark it; finally record the peak and the plot.

2.9.3 Test modes

Test status	Channel	Test plot
SO2 RC1/REV1	1013(Low)	1
	384(Mid)	2
	777(High)	3
SO2 RC3/REV3	1013(Low)	4
	384(Mid)	5
	777(High)	6
SO55 RC1/REV1	1013(Low)	7
	384(Mid)	8
	777(High)	9
SO55 RC3/REV3	1013(Low)	10
	384(Mid)	11
	777(High)	12

2.9.4 Test result

1 Plots for Conducted Spurious Emission

The measuring frequency range was from 9kHz to 10GHz.

1 CDMA MODE (SO2 RC1/REV1 1013 CH.)

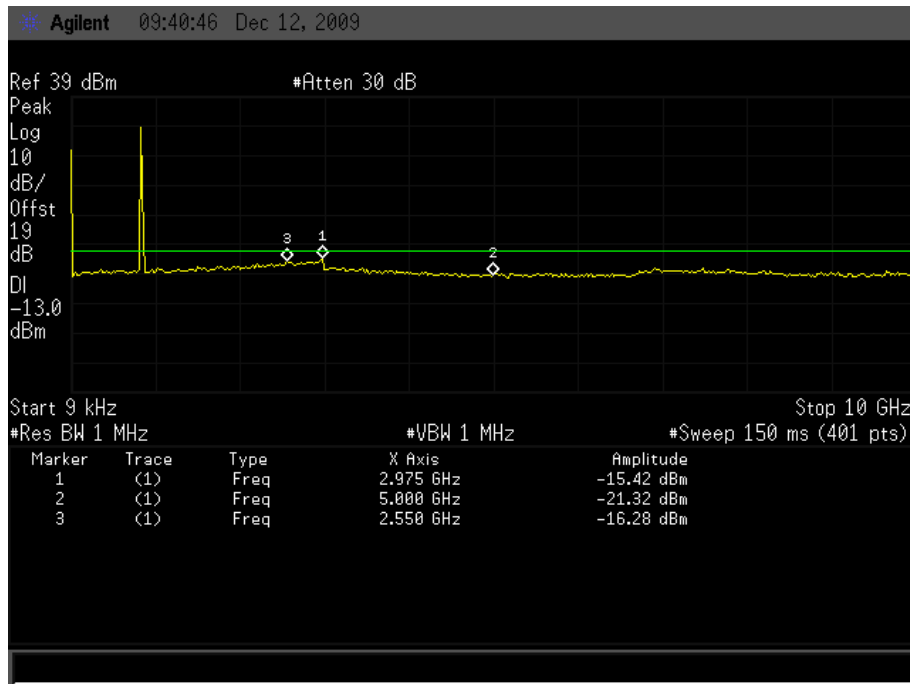

2 CDMA MODE (SO2 RC1/REV1 384 CH.)

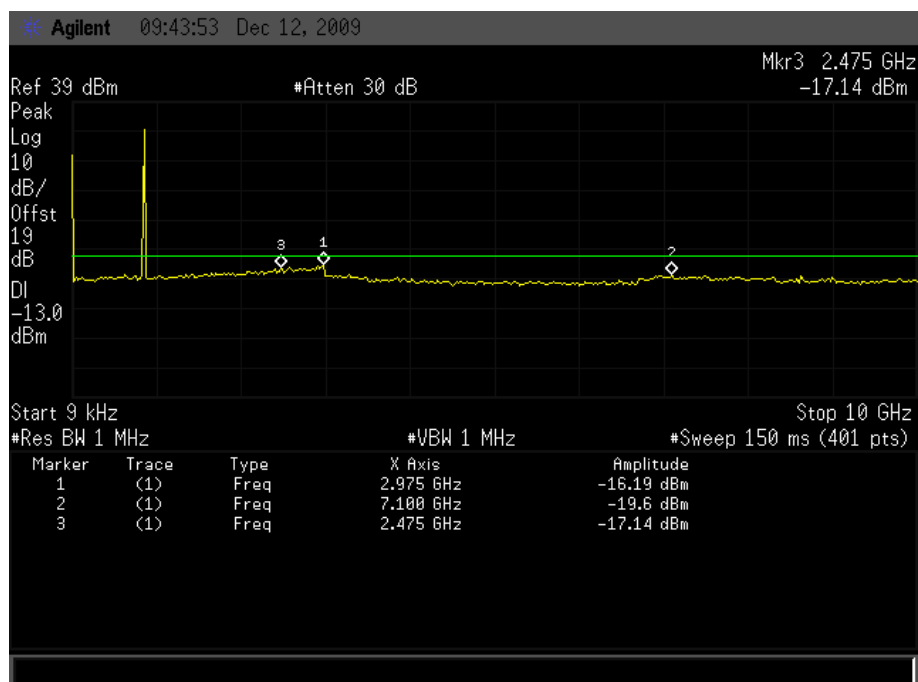

3 CDMA MODE (SO2 RC1/REV1 777 CH.)

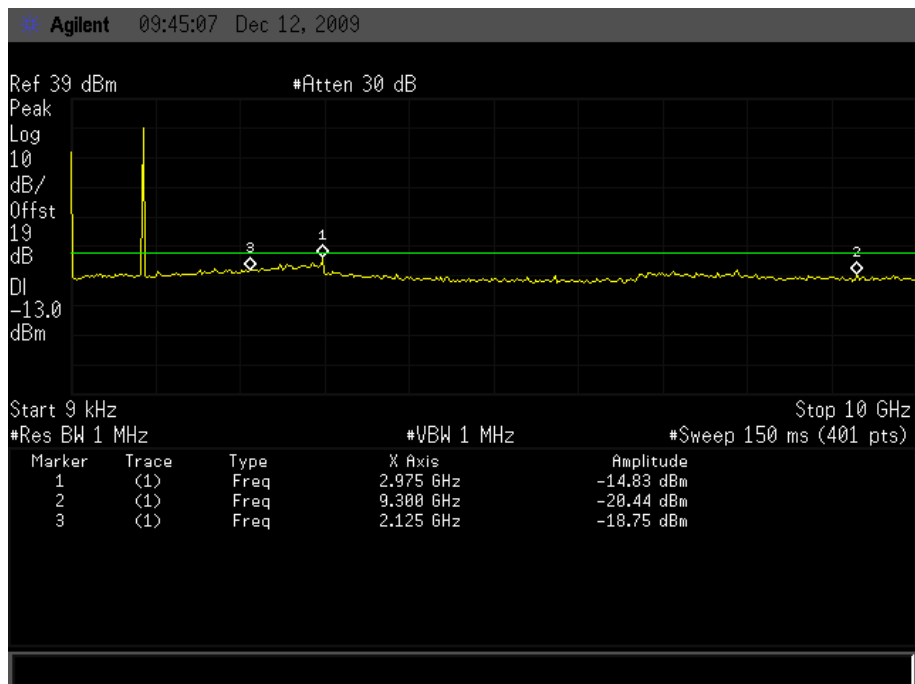

4 CDMA MODE (SO2 RC3/REV3 1013 CH.)

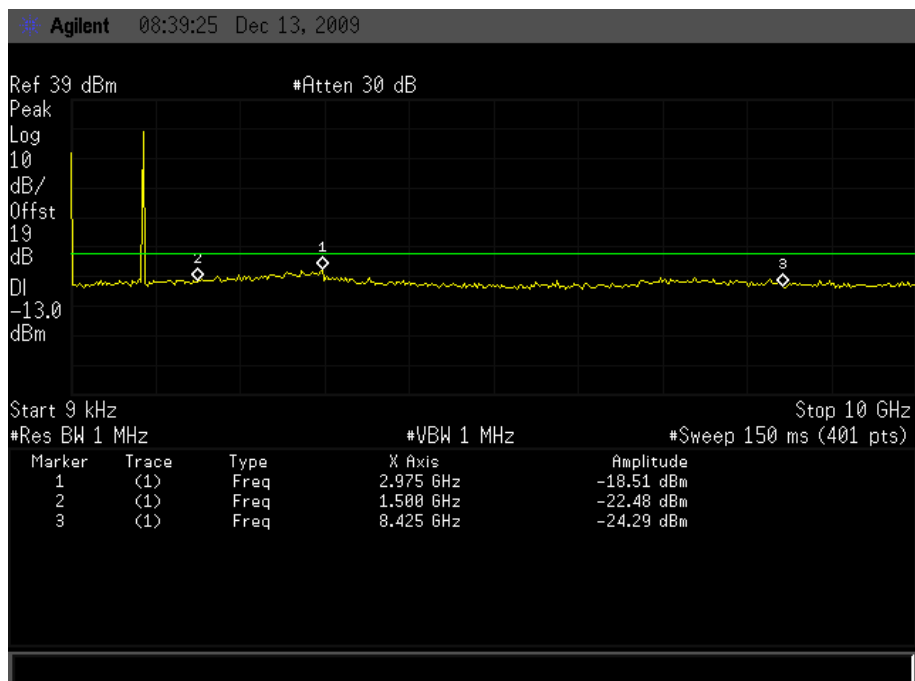

5 CDMA MODE (SO2 RC3/REV3 384 CH.)

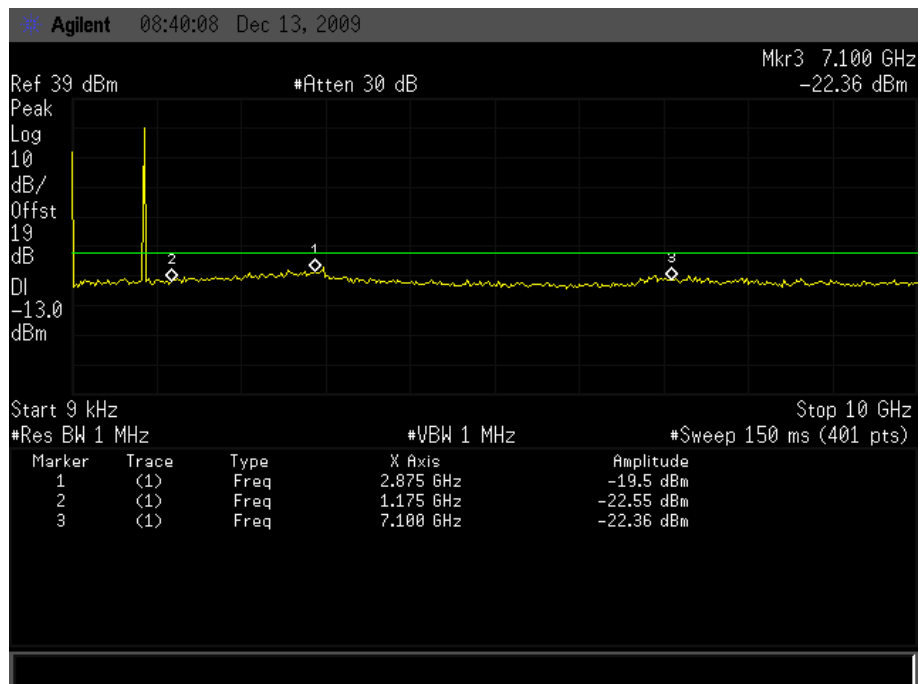

6 CDMA MODE (SO2 RC3/REV3 777 CH.)

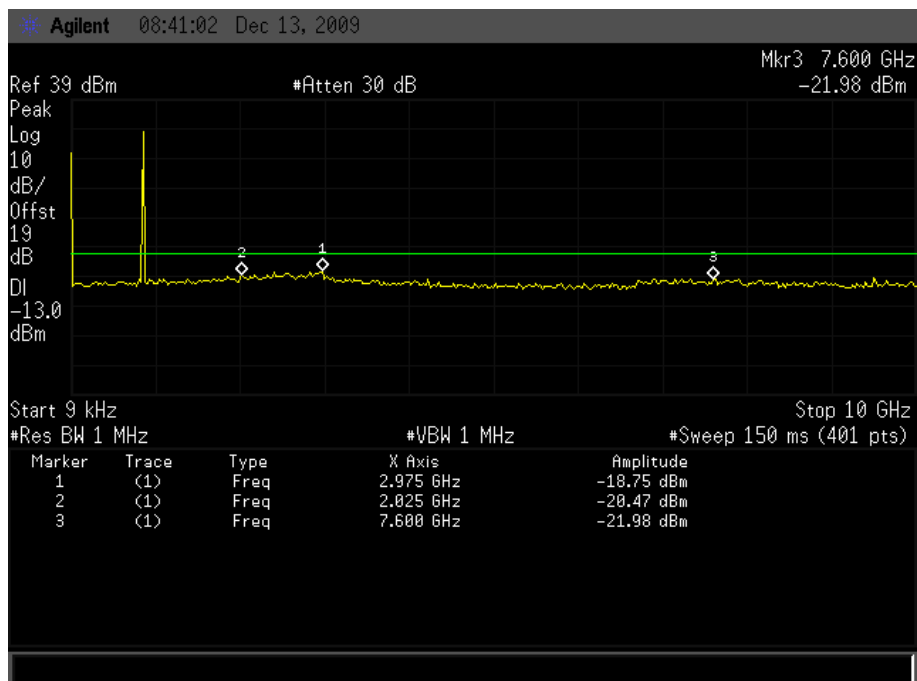

7 CDMA MODE (SO55 RC1/REV1 1013 CH.)

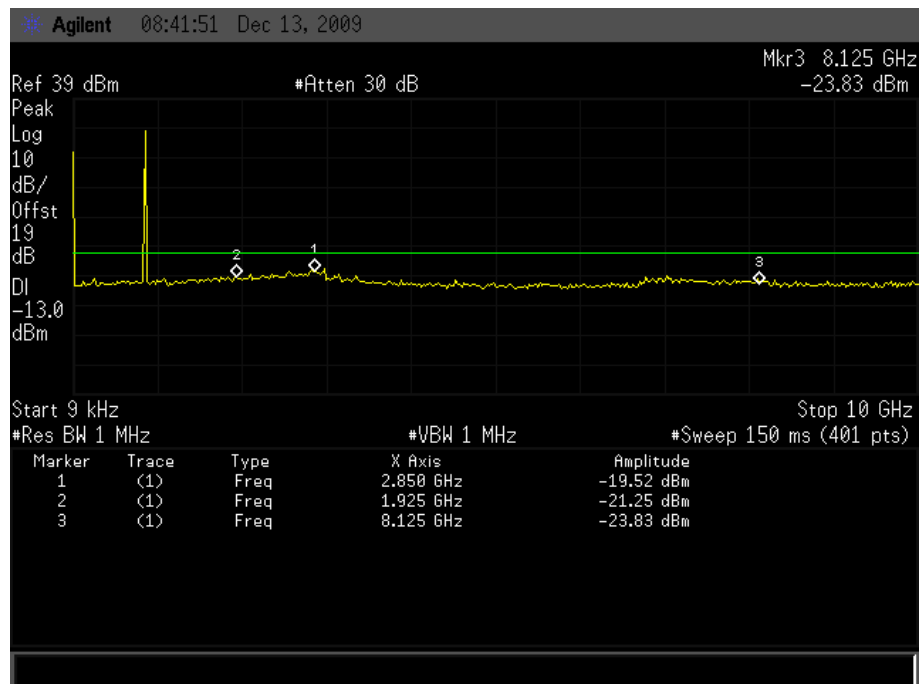

8 CDMA MODE (SO55 RC1/REV1 384 CH.)

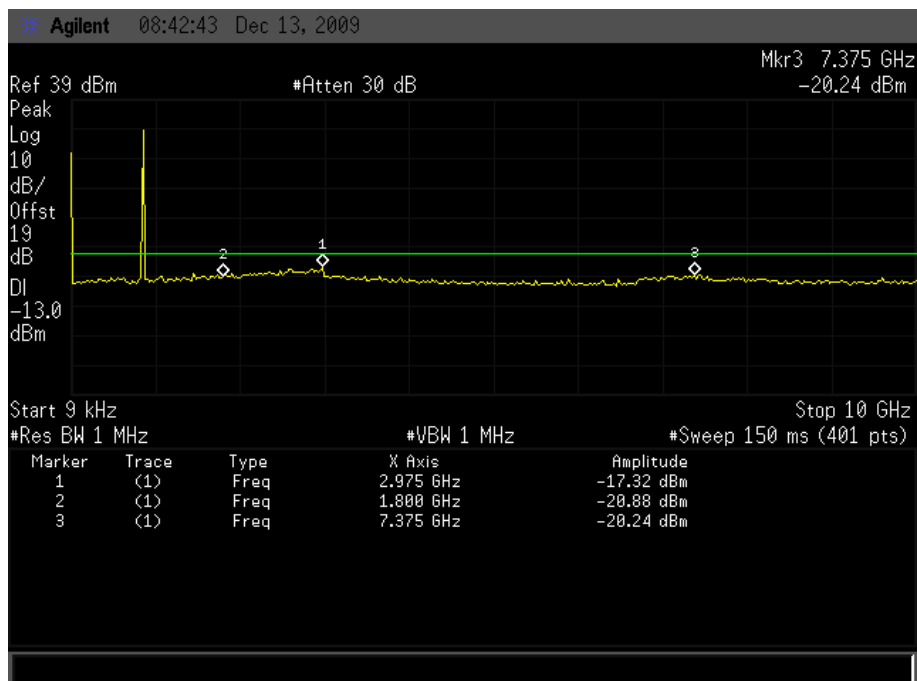

9 CDMA MODE (SO55 RC1/REV1 777CH.)

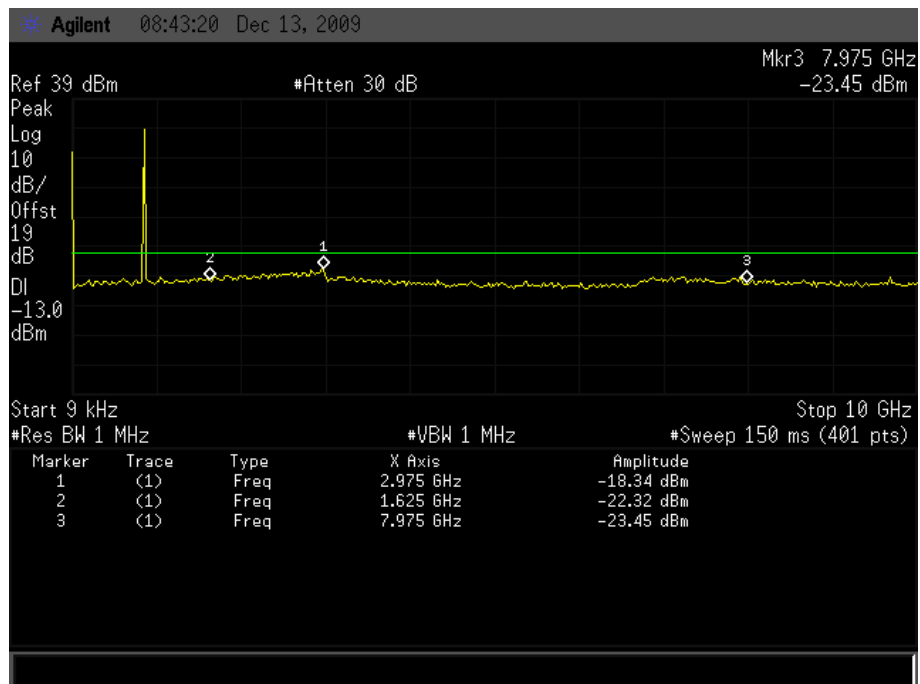

10 CDMA MODE (SO55 RC3/REV3 1013 CH.)

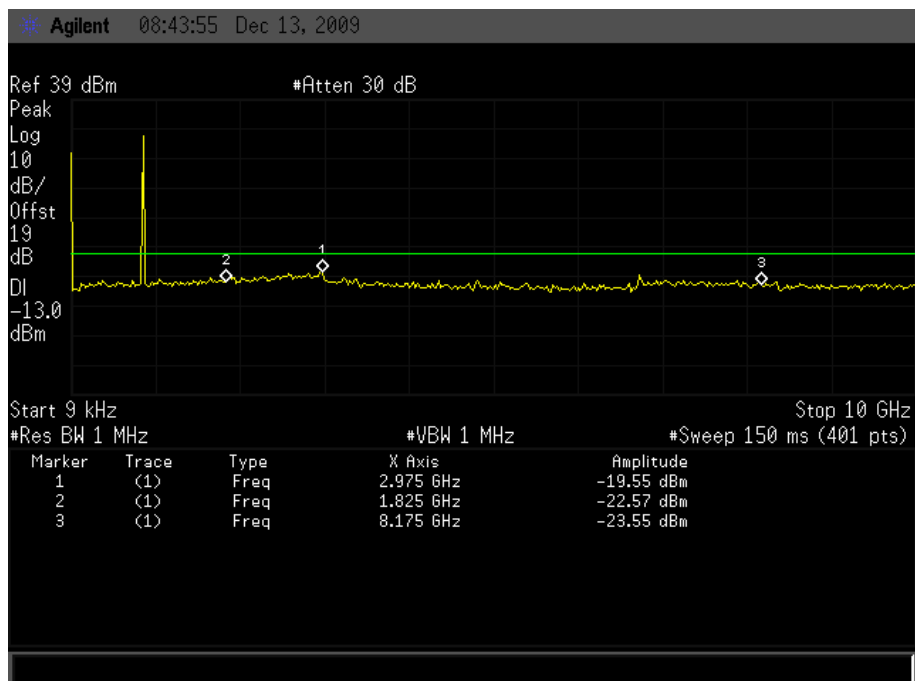

11 CDMA MODE (SO55 RC3/REV3 384 CH.)

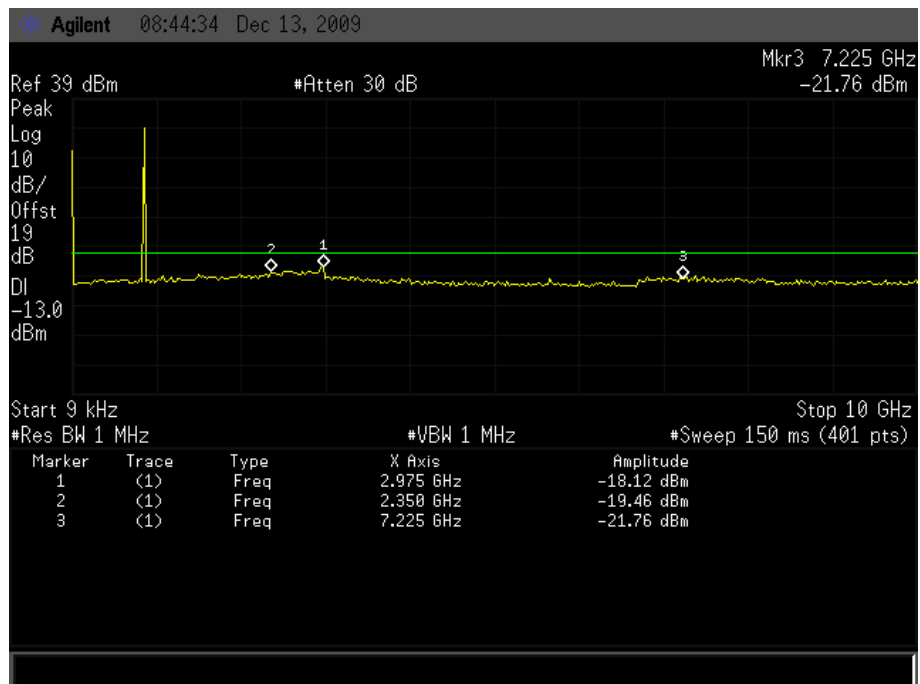

12 CDMA MODE (SO55 RC3/REV3 777 CH.)

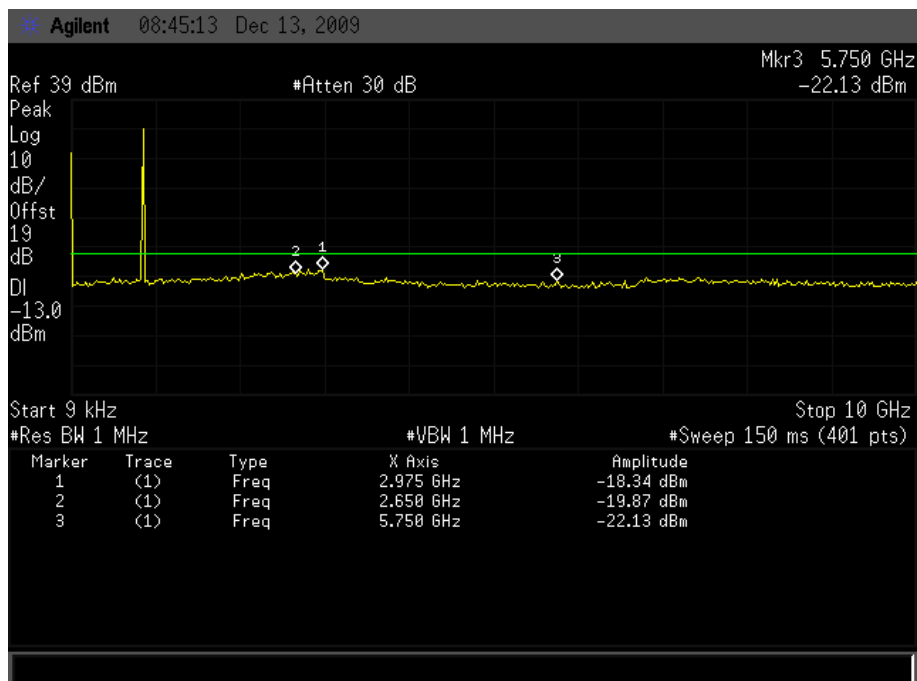

2.10 Transmitter Radiated Power (EIRP/ERP)

2.10.1 Requirement

According to FCC §22.913, the ERP of Cellular mobile transmitters must not exceed 7 Watts (38.5dBm).

2.10.2 Test Procedure

1. Perform test system setup as section 2.4.2.
2. The resolution bandwidth of the Spectrum Analyzer is set to be comparable to the emission bandwidth of the transmitter, e.g. for GSM modulated signal (here used): RBW=VBW=1MHz, for CDMA modulated signal: RBW=VBW=3MHz.
3. The lowest and the highest channel were selected to perform tests respectively. Channel No.1013(lowest) 384(middle)and 777(highest) for cellular band;
4. Employ the bi-log Test Antenna as the test system receiving antenna; set the polarization of the Test Antenna to be the same as that of the EUT transmitting antenna.
5. Set the frequency range of the Spectrum Analyzer suitably to capture the waveform; actuate the Turn Table to turn from 0 degrees to 360 degrees to find the maximum reading via the Spectrum Analyzer, mark the peak; finally record the peak and the plot.
6. Set the frequency range of the Spectrum Analyzer suitably to capture the waveform; search peak and mark it; finally record the peak and the plot.

2.10.3 Test Result

Test status	Channel	Frequency (MHz)	Measured ERP		Limit ERP		Test plots
			dBm	W	dBm	W	
SO2 RC1/REV1	1013(Low)	824.705	27.42	0.552	< 38.5	< 7	1
	384(Mid)	836.875	27.31	0.538	< 38.5	< 7	2
	777(High)	848.625	26.86	0.738	< 38.5	< 7	3
SO2 RC3/REV3	1013(Low)	824.625	27.26	0.532	< 38.5	< 7	4
	384(Mid)	836.575	26.99	0.500	< 38.5	< 7	5
	777(High)	848.325	26.96	0.497	< 38.5	< 7	6
SO55 RC1/REV1	1013(Low)	824.735	26.56	0.453	< 38.5	< 7	7
	384(Mid)	836.565	25.90	0.389	< 38.5	< 7	8
	777(High)	848.335	26.16	0.413	< 38.5	< 7	9
SO55 RC3/REV3	1013(Low)	824.625	26.42	0.439	< 38.5	< 7	10
	384(Mid)	836.875	25.87	0.386	< 38.5	< 7	11
	777(High)	848.625	26.31	0.428	< 38.5	< 7	12

Note: The worst case (SO2 RC1/REV1) only recorded in this report.

1. Plot when the channel number set to 1013

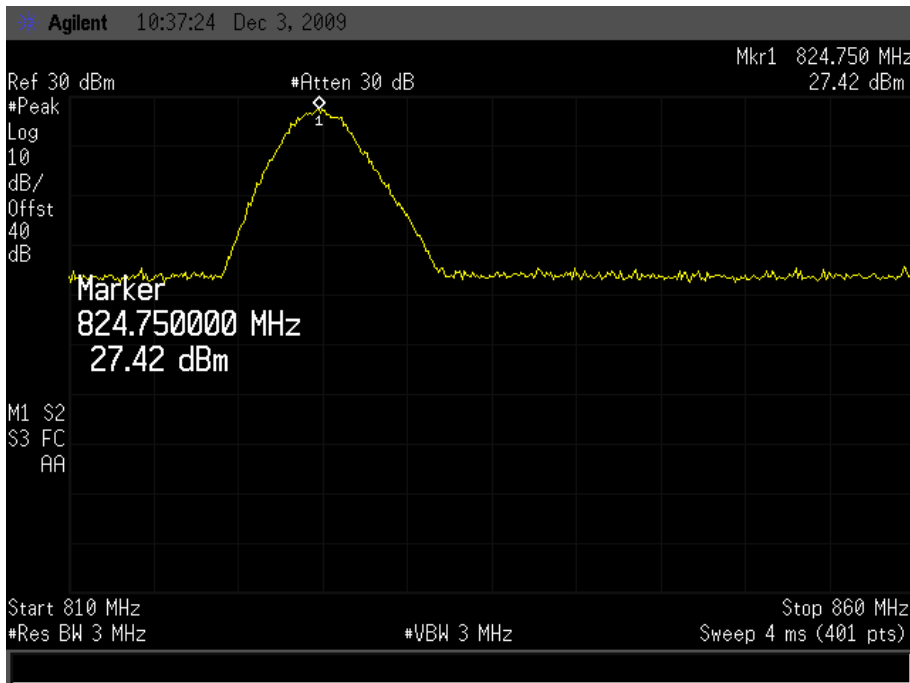

2. Plot when the channel number set to 384:

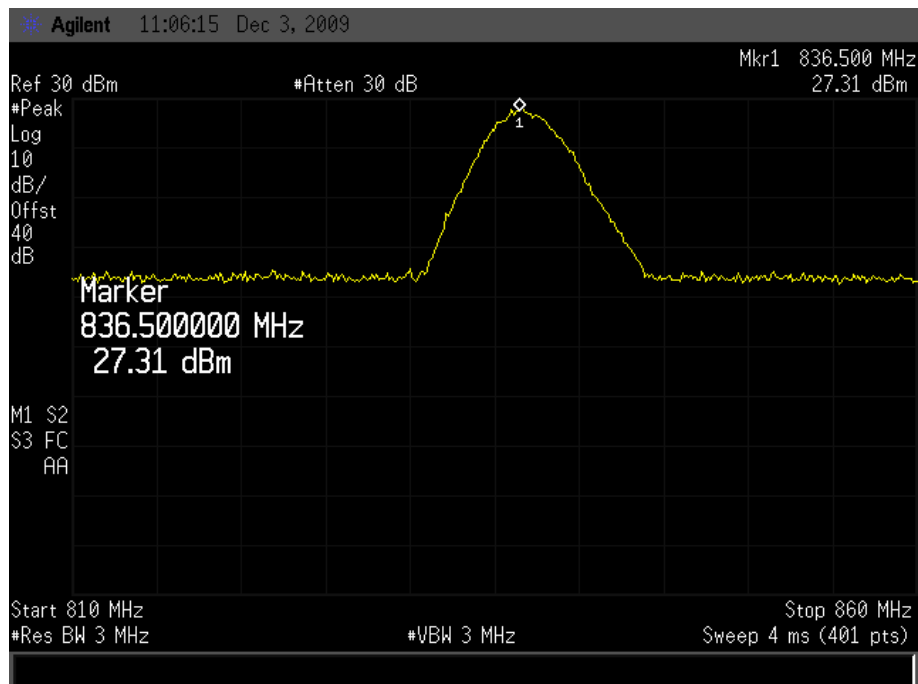

3. Plot when the channel number set to 777:

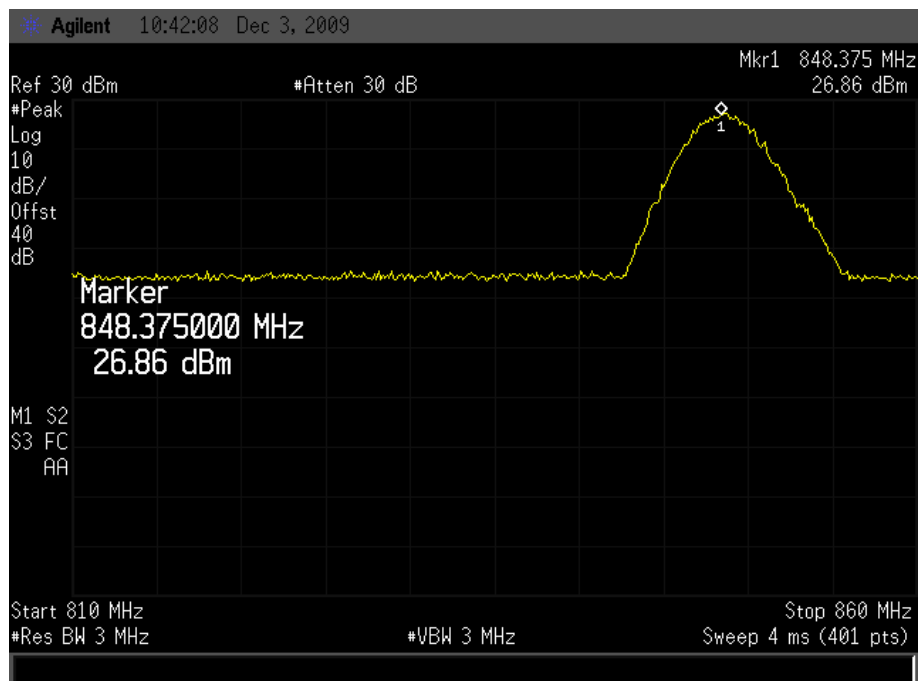

2.11 Radiated Spurious Emission

2.11.1 Requirement

According to FCC §22.917(a) and §24.238(a), the power of any emission outside of the authorized operating frequency ranges must be attenuated below the transmitting power (P) by a factor of at least $43+10*\log(P)$ dB. This calculated to be -13dBm.

2.11.2 Test Procedure

1. Perform test system setup as section 2.4.2
2. Make a limit line whose value is -13dBm on the Spectrum Analyzer, and set the RBW of the Spectrum Analyzer to 1MHz.
3. The lowest and the highest channel were selected to perform tests respectively. Channel No.1013(lowest) 384(middle)and 777(highest) for cellular band;
4. Employ the bi-log Test Antenna as the test system receiving antenna and set the frequency range of the Spectrum Analyzer from 30MHz to 3GHz.
5. The measurement is performed with the Test Antenna at both horizontal and vertical polarization respectively. Set the polarization of the Test Antenna to be horizontal.
6. Actuate the Turn Table to turn from 0 degrees to 360 degrees to find the maximum reading via the Spectrum Analyzer, mark the fundamental frequency and the harmonics thereof, after then record the harmonics and the plot.
7. Set the polarization of the Test Antenna to be vertical, then repeat step 6.
8. Employ the horn Test Antenna as the test system receiving antenna and set the frequency range of the Spectrum Analyzer from 30MHz to 10th harmonic of the fundamental frequency (here used 10GHz), then repeat step 5 to 7.
9. Set the frequency range of the Spectrum Analyzer suitably to capture the waveform; search peak and mark it; finally record the peak and the plot.

2.11.3 Test modes

Test status	Channel	Test plots
SO2 RC1/REV1	1013(Low)	1
	384(Mid)	2
	777(High)	3
SO2 RC3/REV3	1013(Low)	4
	384(Mid)	5
	777(High)	6
SO55 RC1/REV1	1013(Low)	7
	384(Mid)	8
	777(High)	9
SO55 RC3/REV3	1013(Low)	10
	384(Mid)	11
	777(High)	12

Note: The worst case (SO55 RC3/REV3) only recorded in this report

2.11.4 Test plots

TCH number set to 1013 (824.7MHz) Test Antenna Vertical

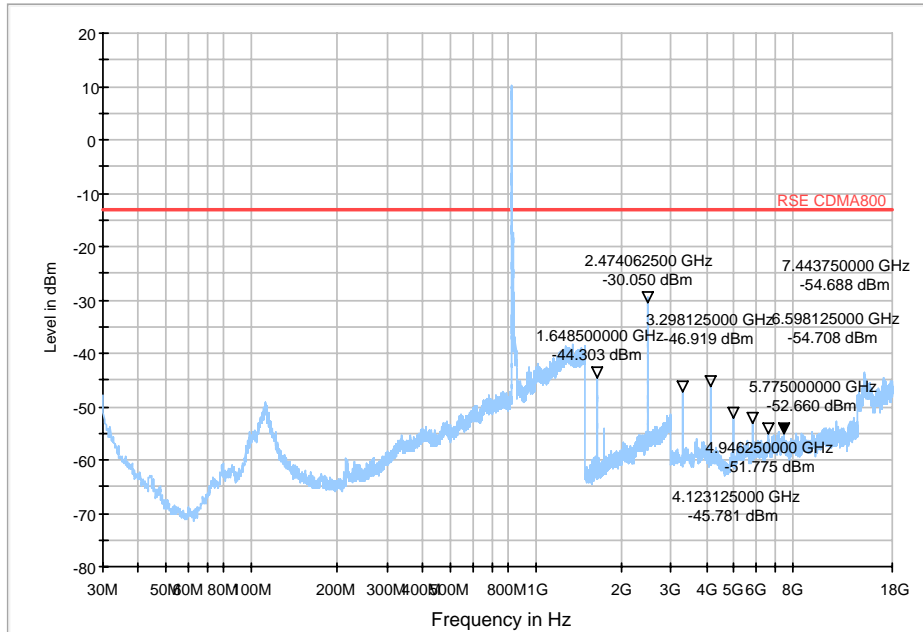

TCH number set to 1013 (824.7MHz) Test Antenna Horizontal

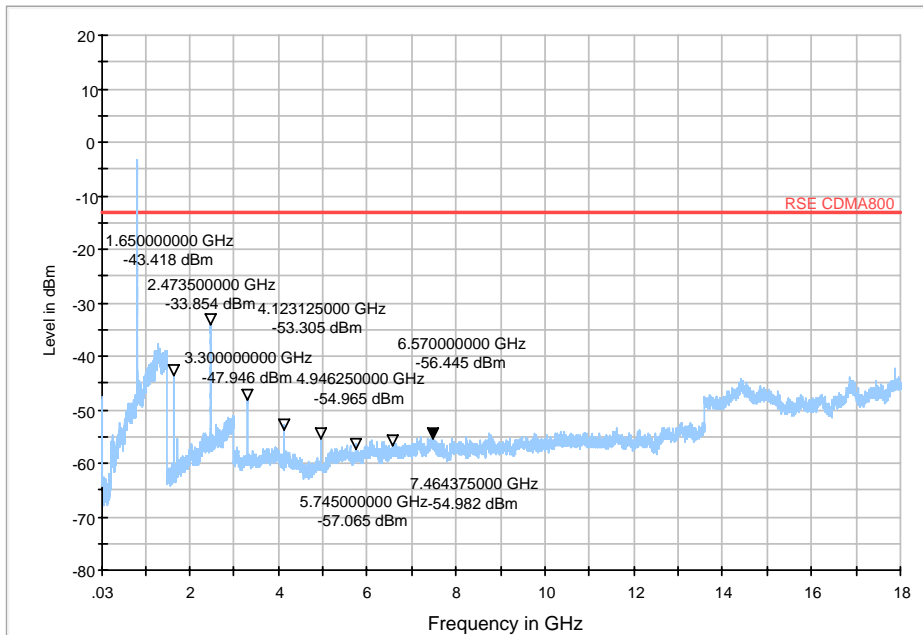

TCH number set to 384 (836.52MHz) Test Antenna Vertical

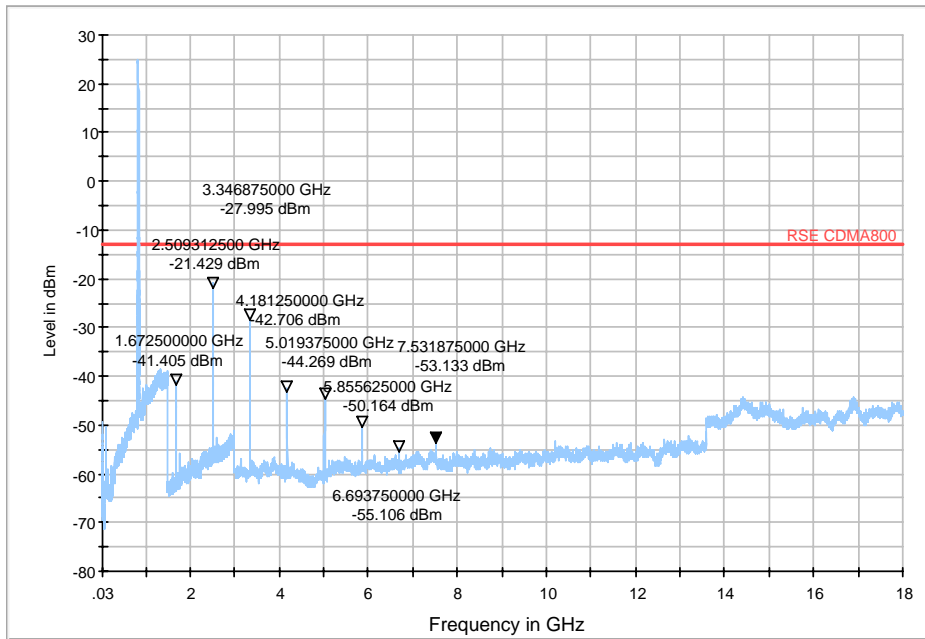

TCH number set to 384 (836.52MHz) Test Antenna Horizontal

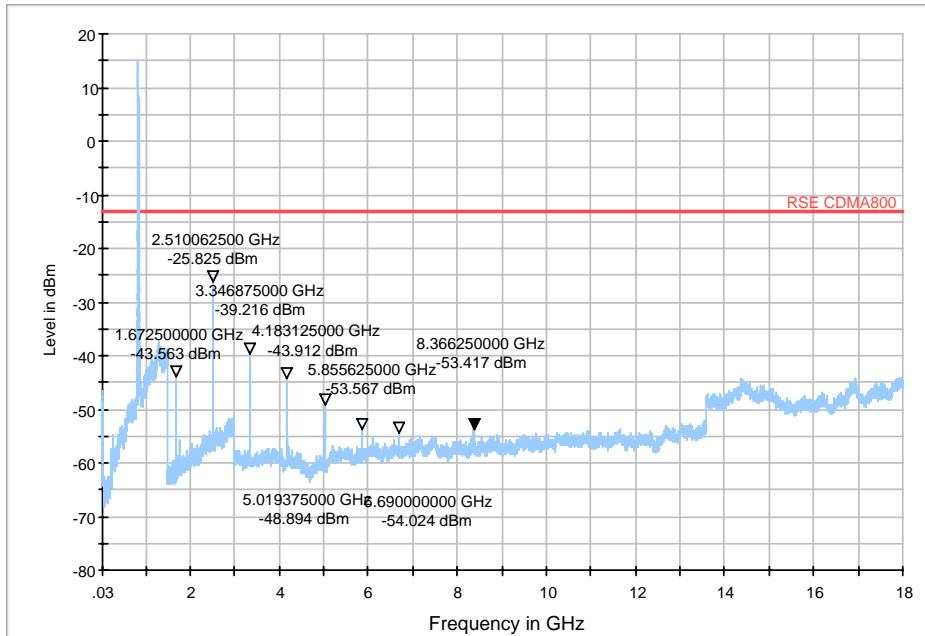

TCH number set to 777 (848.31MHz) Test Antenna Vertical

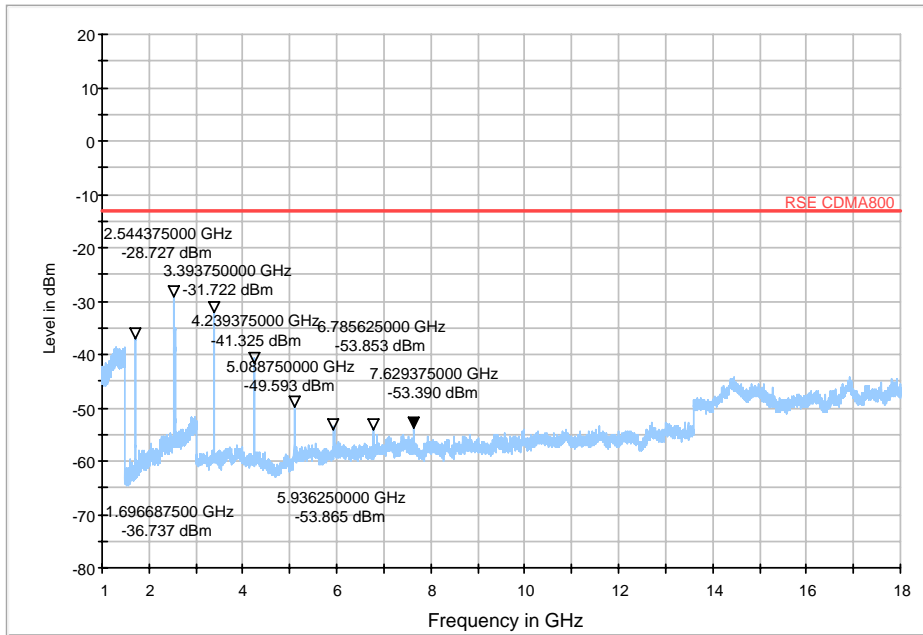

TCH number set to 777 (848.31MHz) Test Antenna Horizontal

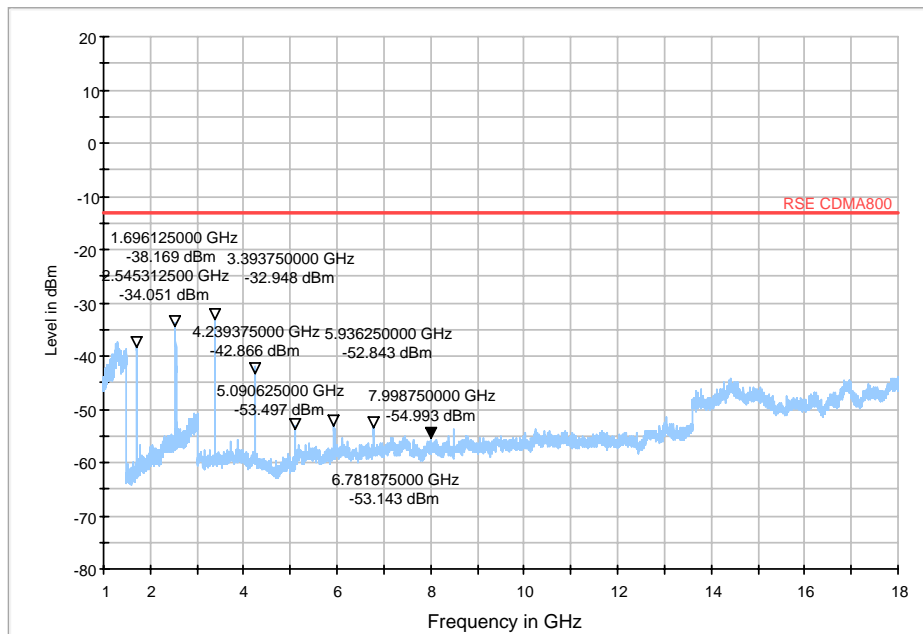

2.12 Frequency Stability

2.12.1 Frequency Stability Requirement

According to FCC §22.355, the frequency stability shall be sufficient to ensure that the fundamental emission stays within the authorized frequency block.

According to FCC §2.1055, the test conditions are:

(a) Temperature:

The temperature is varied from -30°C to $+50^{\circ}\text{C}$ at intervals of not more than 10°C .

(b) Primary Supply Voltage:

For hand carried battery powered equipment, the primary supply voltage is reduced to the battery operating end point which shall be specified by the manufacture. The supply voltage shall be measured at the input to the cable normally provided with the equipment, or at the power supply terminals if cables are not normally provided.

2.12.2 Test Procedure

1. Perform test system setup as section 2.4.3.
2. Set the voltage of the DC Power Supply to normal supply voltage (here used 4.0V) and the temperature of the Temperature Chamber to vary from -30°C to $+50^{\circ}\text{C}$ at intervals of 10°C .
3. At each temperature level, the EUT is powered off and kept in the Temperature Chamber for two hours. After sufficient stabilization, turn on the EUT, command it via the System Simulator (SS) to operate at the maximum output power i.e. A communication link is established between the EUT and the SS.
4. The frequency deviation is measured (directly read from the SS, which can report the parameter) within three minutes.
5. Set the frequency range of the Spectrum Analyzer suitably to capture the waveform; search peak and mark it; finally record the peak and the plot.
6. Adjust the temperature of the Temperature Chamber as specified in step 2, then repeat step 3 to 7.
7. Set the voltage of the DC Power Supply to high extreme supply voltage (here used 4.5V) and the temperature of the Temperature Chamber to normal (here used $+22^{\circ}\text{C}$), then repeat step 3 to 8.
8. Set the voltage of the DC Power Supply to low extreme supply voltage (here used 3.4V) and the temperature of the Temperature Chamber to normal (here used $+22^{\circ}\text{C}$), then repeat step 3 to 8.

2.12.3 Test modes

Test status	Channel	Test plots
SO2 RC1/REV1	1013(Low)	1
	384(Mid)	2
	777(High)	3
SO2 RC3/REV3	1013(Low)	4
	384(Mid)	5
	777(High)	6
SO55 RC1/REV1	1013(Low)	7
	384(Mid)	8
	777(High)	9
SO55 RC3/REV3	1013(Low)	10
	384(Mid)	11
	777(High)	12

2.12.4 Test Result

Test Conditions		Frequency Deviation (Hz) at Channels Used				
Voltage	Temperature	Test status	1013	384	777	Limit
4.0V	-30°C	SO2 RC1/REV1	-9.37	8.26	7.21	1013CH±2061.75Hz 384CH±2091.30Hz 777CH±2120.775Hz
		SO2 RC3/REV3	-9.12	8.96	7.01	
		SO55 RC1/REV1	-9.25	8.06	7.81	
		SO55 RC3/REV3	-9.36	8.06	7.21	
	-20°C	SO2 RC1/REV1	-9.03	-6.32	7.56	
		SO2 RC3/REV3	-9.23	-6.92	7.06	
		SO55 RC1/REV1	-9.53	-6.12	7.56	
		SO55 RC3/REV3	-9.28	-6.32	7.56	
	-10°C	SO2 RC1/REV1	-9.69	8.29	8.36	
		SO2 RC3/REV3	-9.19	8.09	6.06	
		SO55 RC1/REV1	-9.69	8.29	6.86	
		SO55 RC3/REV3	-9.89	8.29	6.36	
	0°C	SO2 RC1/REV1	9.02	5.13	6.05	
		SO2 RC3/REV3	9.32	6.63	6.35	
		SO55 RC1/REV1	9.02	6.23	6.05	
		SO55 RC3/REV3	9.32	6.03	6.15	
	+10°C	SO2 RC1/REV1	5.10	8.26	5.07	
		SO2 RC3/REV3	5.20	8.06	5.87	
		SO55 RC1/REV1	5.00	7.96	5.57	
		SO55 RC3/REV3	5.20	8.26	5.87	
	+20°C	SO2 RC1/REV1	10.02	5.47	2.56	
		SO2 RC3/REV3	10.42	6.27	246	
		SO55 RC1/REV1	10.02	5.27	2.56	
		SO55 RC3/REV3	10.20	5.07	2.56	
	+30°C	SO2 RC1/REV1	9.32	6.98	2.02	
		SO2 RC3/REV3	9.36	6.08	2.02	
		SO55 RC1/REV1	10.42	6.98	2.02	
		SO55 RC3/REV3	9.32	6.08	2.72	
	+40°C	SO2 RC1/REV1	11.21	-5.21	3.24	
		SO2 RC3/REV3	11.99	-5.81	3.74	
		SO55 RC1/REV1	10.01	-5.01	1.94	
		SO55 RC3/REV3	11.91	-5.21	2.24	
	+50°C	SO2 RC1/REV1	10.25	6.78	3.39	
		SO2 RC3/REV3	10.36	5.18	2.02	
		SO55 RC1/REV1	10.99	5.08	2.05	
		SO55 RC3/REV3	10.05	6.79	2.08	
SO55 RC1/REV1		8.12	4.29	2.01		
SO55 RC3/REV3		8.10	4.89	2.87		
Result: PASS						



Test Conditions		Frequency Deviation (Hz) at Channels Used				
Voltage	Temperature	Test status	1013	384	777	Limit
4.5V	+22°C	SO2 RC1/REV1	9.38	8.14	2.65	1013CH±2061.75Hz 384CH±2091.30Hz 777CH±2120.775Hz
		SO2 RC3/REV3	10.08	8.84	2.25	
		SO55 RC1/REV1	9.08	8.17	4.85	
		SO55 RC3/REV3	9.30	8.10	2.59	
3.4V	+22°C	SO2 RC1/REV1	8.65	4.96	3.54	
		SO2 RC3/REV3	8.36	4.17	2.59	
		SO55 RC1/REV1	8.12	4.29	2.01	
		SO55 RC3/REV3	8.10	4.89	2.87	
Result: PASS						

** END OF REPORT **