

**HYUNDAI CALIBRATION & CERTIFICATION TECH. CO., LTD.**



PRODUCT COMPLIANCE DIVISION  
SAN 136-1, AMI-RI , BUBAL-EUP, ICHEON-SI, KYOUNGKI-DO, 467-701, KOREA  
TEL: +82 31 639 8518 FAX: +82 31 639 8525 [www.hct.co.kr](http://www.hct.co.kr)



**CERTIFICATE OF COMPLIANCE**

**FCC Part 22 Certification**

**AXESSTEL INC.**

6305 LUSK BLVD  
SAN DIEGO, CA 92121

FRN: 0008827313

Date of Issue: August 23, 2006

Test Report No.: HCT-SAR06-0806

Test Site: HYUNDAI CALIBRATION & CERTIFICATION  
TECHNOLOGIES CO., LTD.

FRN: 0005866421

**FCC ID** :

**PH7PX220**

**APPLICANT** :

**AXESSTEL INC.**

EUT Type:	Fixed WLL Telephone (CDMA) - Prototype
Tx Frequency:	824.70 — 848.31 MHz (CDMA)
Rx Frequency:	869.70 — 893.31 MHz (CDMA)
Max. RF Output Power:	0.293W ERP CDMA (24.7dBm)
Trade Name/Model(s):	AXESSTEL / PX220
FCC Classification:	Licensed Non-Broadcast station Transmitter - TNB
Application Type:	Certification
FCC Rule Part(s):	§22(H), §2
Maximum SAR:	1.02W/kg CDMA Body SAR
Antenna Specifications:	Manufacturer: HANKOOK ANTENNA CO., LTD. PN: TB4-800T1(B) (Length= 226± 2.0mm)
Emission Designator(s):	1M28F9W

This equipment has been shown to be capable of compliance with the applicable technical standards as indicated in the measurement report and was tested in accordance with the measurement procedures specified in § 2.947.

I attest to the accuracy of data. All measurements reported herein were performed by me or were made under my supervision and are correct to the best of my knowledge and belief. I assume full responsibility for the completeness of these measurements and vouch for the qualifications of all persons taking them.

Hyundai C-Tech Co., Ltd. Certifies that no party to this application has been denied FCC benefits pursuant to section 5301 of the Anti- Drug Abuse Act of 1998, 21 U.S. C. 853(a)

**Report prepared by : Ki-Soo Kim**

**Manager of Product Compliance Team**

This report only responds to the tested sample and may not be reproduced, except in full, without written approval of the HCT Co., Ltd.

---

## Table of Contents

---

<b>ATTACHMENT A: COVER LETTER(S)</b>	
<b>ATTACHMENT B: ATTESTATION STATEMENT(S)</b>	
<b>ATTACHMENT C: TEST REPORT</b>	
1.1 SCOPE -----	3
2.1 INTRODUCTION -----	4
3.1 INSERTS PER §2.1033(d)-----	5
4.1 DESCRIPTION OF TESTS-----	6-17
5.1 EFFECTIVE RADIATED POWER OUTPUT -----	18
6.1 RADIATED MEASUREMENTS-----	19-20
7.1 FREQUENCY STABILITY -----	21
8.1 PLOTS OF EMISSIONS-----	22
9.1 LIST OF TEST EQUIPMENT -----	23
10.1 SAMPLE CALCULATIONS -----	24
11.1 CONCLUSION-----	25
<b>ATTACHMENT D: TEST PLOTS</b>	
<b>ATTACHMENT E: FCC ID LABEL &amp; LOCATION</b>	
<b>ATTACHMENT F: TEST SETUP PHOTOGRAPHS</b>	
<b>ATTACHMENT G: EXTERNAL PHOTOGRAPHS</b>	
<b>ATTACHMENT H: INTERNAL PHOTOGRAPHS</b>	
<b>ATTACHMENT I: BLOCK DIAGRAM (S)</b>	
<b>ATTACHMENT J: CIRCUIT DIAGRAMS &amp; DESCRIPTION</b>	
<b>ATTACHMENT K: PARTS LIST</b>	
<b>ATTACHMENT L: OPERATIONAL DESCRIPTION</b>	
<b>ATTACHMENT M: USER'S MANUAL</b>	
<b>ATTACHMENT N: SAR MEASUREMENT REPORT</b>	
<b>ATTACHMENT O: SAR TEST DATA</b>	
<b>ATTACHMENT P: SAR TEST SETUP PHOTOGRAPHS</b>	
<b>ATTACHMENT Q: DIPOLE VALIDATION</b>	
<b>ATTACHMENT R: PROBE CALIBRATION</b>	
<b>ATTACHMENT S: DIPOLE CALIBRATION</b>	
<b>ATTACHMENT T: EMI MEASUREMENT REPORT</b>	

# MEASUREMENT REPORT

## 1.1 SCOPE

Measurement and determination of electromagnetic emissions (EME) of radio frequency devices including intentional and/or unintentional radiators for compliance with the technical rules and regulations of the Federal Communications Commission.

### General Information

<b>Company Name:</b>	<b>AXESSTEL INC.</b>
<b>Address:</b>	<b>6305 LUSK BLVD. SAN DIEGO, CA 92121, U.S.A</b>
<b>Attention:</b>	<b>Mr. David Kim</b>
<b>Tel. / Fax :</b>	<b>858- 625-2100 / 858- 625- 2110</b>
<b>E-Mail :</b>	<b>dskim@axesstel.com</b>

- FCC ID: PH7 PX220
- Quantity: Quantity production is planned
- EUT Type: Fixed WLL Telephone (CDMA) - Prototype
- Trade Name: AXESSTEL
- Model(s): PX220
- Serial Number(s): PH7PX220-20060601
- Emission Designator(s): 1M28F9W
- Tx Frequency: 824.70 – 848.31 MHz (CDMA)
- Rx Frequency: 869.70 – 893.31 MHz (CDMA)
- Application Type: Certification
- FCC Classification: Licensed Non-Broadcast station Transmitter - TNB
- FCC Rule Part(s): §22(H), §2
- Modulation(s): CDMA
- Antenna Type: Fixed
- Max RF. Output Power: 0.293W ERP CDMA (24.7dBm)
- Date(s) of Tests: August 22, 2006
- Place of Tests: Hyundai C-Tech. EMC Lab.  
Icheon, Kyounki-Do, KOREA
- Report Serial No.: HCT-SAR06-0806

## 2.1 INTRODUCTION

---

### EUT DESCRIPTION

The AXESSTEL INC. PX220 Fixed WLL Telephone (CDMA). Its basic purpose is used for communications. It transmits from CDMA(824.70~848.31)MHz and receives from CDMA(869.70~893.31)MHz. The RF power is rated at CDMA (0.293W)

### MEASURING INSTRUMENT CALIBRATION

The measuring equipment, which was utilized in performing the tests documented herein, has been calibrated in accordance with the manufacturer's recommendations for utilizing calibration equipment, which is traceable to recognized national standards.

### Test Facility

The open area test site and conducted measurement facility used to collect the radiated data are located at the 254-1, Maekok-Ri, Hobup-Myun, Ichon-Si, Kyoungki-Do, 467-701, KOREA. The site is constructed in conformance with the requirements of ANSI C63.4 and CISPR Publication 22. Detailed description of test facility was submitted to the Commission and accepted dated July 6, 2006 (Confirmation Number: 90661)

## **3.1 INSERTS**

---

### **Function of Active Devices (Confidential)**

The Function of active devices are shown in Attachment K.

### **Block/Circuit Diagrams & Description (Confidential)**

The circuit diagrams & description are shown in Attachment J, and the block diagrams are shown in Attachment I.

### **Operating Instructions**

The instruction manual is shown in Attachment M.

### **Parts List & Tune-Up Procedure (Confidential)**

The parts list & tune-up procedure are shown in Attachment L.

### **Description of Freq. Stabilization Circuit (Confidential)**

The description of frequency stabilization circuit is shown in Attachment K.

### **Description for Suppression of Spurious Radiation, for Limiting Modulation, and Harmonic Suppresion Circuits (Confidential)**

The description of suppression stabilization circuits are shown in Attachment K

## 4.1 DESCRIPTION OF TESTS

### Out power Variation

#### Test condition to measure the Output power

This device was tested under all R.C.s and worst case is reported with RC3/SO55, with “All Up” power control bits.

The following procedures were followed according to FCC "SAR Measurement Procedures for 3G Devices", May 2006

1. If the mobile station supports Reverse TCH RC 1 and Forward TCH RC 1, set up a call using Fundamental Channel Test Mode 1 (RC=1/1) with 9600 bps data rate only.
2. Under RC1, C.S0011 Table 4.4.5.2-1 (Table 1) parameters were applied.
3. If the MS supports the RC 3 Reverse FCH, RC3 Reverse SCH0 and demodulation of RC 3, 4, or 5, set up a call using Supplemental Channel Test Mode 3 (RC 3/3) with 9600 bps Fundamental Channel and 9600 bps SCH0 data rate Channel and 9600 bps SCH0 data rate.
4. Under RC3, C.S0011 Table 4.4.5.2-2(Table 2) was applied.
5. FCHs were configured at full rate for maximum SAR with “All Up” power control bits.

**Parameters for Max. Power for RC1**

Parameter	Units	Value
$I_{or}$	dBm/1.23 MHz	-104
$\frac{Pilot E_c}{I_{or}}$	dB	-7
$\frac{Traffic E_c}{I_{or}}$	dB	-7.4

Table. 1

**Parameters for Max. Power for RC3**

Parameter	Units	Value
$I_{or}$	dBm/1.23 MHz	-86
$\frac{Pilot E_c}{I_{or}}$	dB	-7
$\frac{Traffic E_c}{I_{or}}$	dB	-7.4

Table. 2

### Maximum Power Output table for PX220

Band	Channel	SO2	SO2	SO55	SO55	TDSOSO32
		RC1/1	RC3/3	RC1/1	RC3/3	RC3/3
CDMA	1013	24.05	24.01	24.02	24.02	24.01
	363	24.02	24.06	24.01	24.00	24.04
	777	24.04	24.05	23.99	24.02	23.98

Table. 3

## 4.2 RF Power output.

### Test Set-up

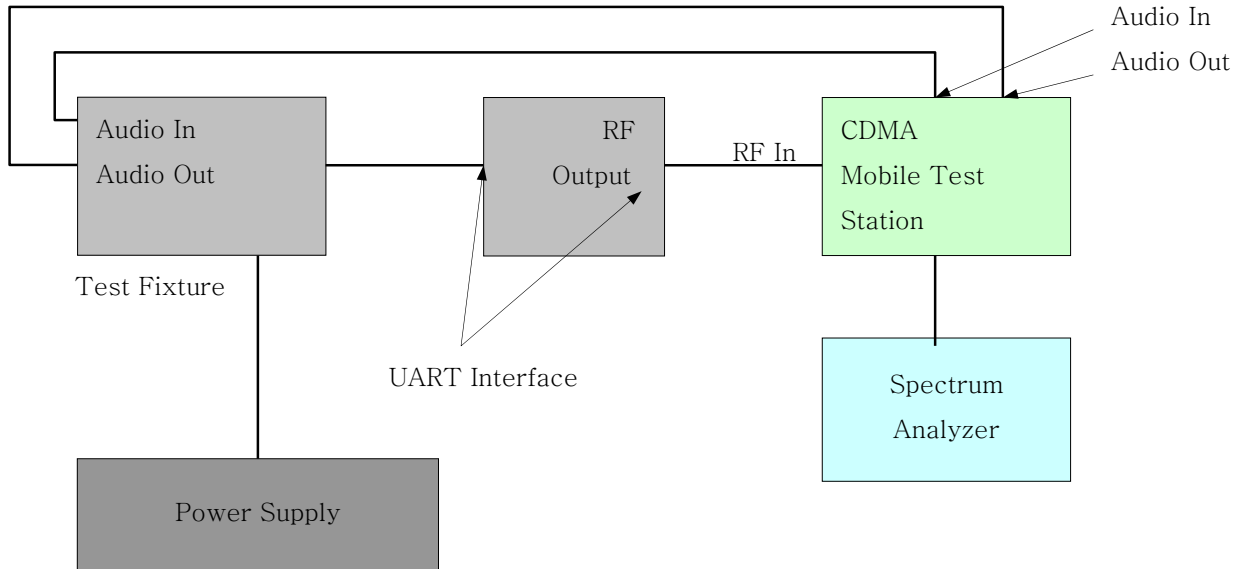

UART Interface: The UART Interface has a serial communication link and RF Interface port that can be used to test , debug or upgrade the phone's functions and characteristics.

EUT : Equipment Under Test

### Test Procedure

The power is read at the specturm anlalyzer through the duplex port of CDMA mobile test station.

RF power output is measured at the RF output terminal (UART Interface) on the bottom side of the EUT.

### 4.3 Effective Radiated Power.

#### Test Set-up

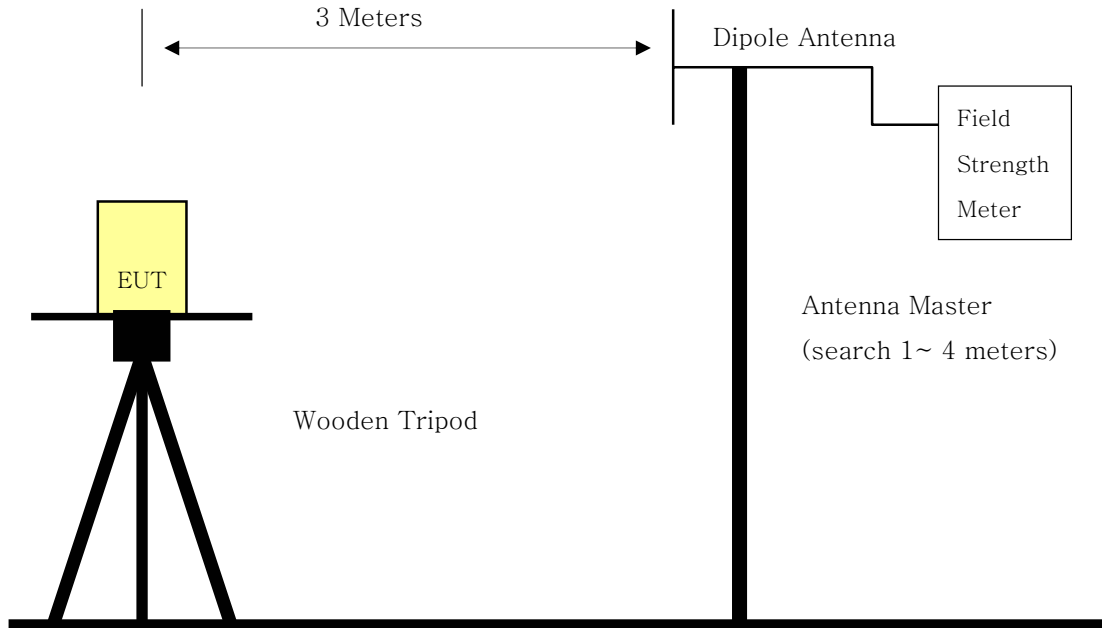

Open Field Test Site

#### Test Procedure

The measurement facilities used for this test have been documented in previous filings with the commission pursuant to section 2.948.

The open field test site is situated in open field with ground screen whose site attenuation characteristics meet ANSI C63.4 –1992. A mast capable of lifting the receiving antenna from a height of one to four meters is used together with a rotatable wooden platform mounted at three from the antenna mast.

- 1) The EUT mounted on a wooden tripod is 0.8 meter above test site ground level.
- 2) During the test , the turn table is rotated and the antenna height is also varied from 1 to 4 meters until the maximum signal is found.
- 3) Record the field strength meter's level.
- 4) Replace the EUT with  $\lambda/2$  dipole antenna that is connected to a calibrated signal generator.
- 5) Increase the signal generator output till the field strength meter's level is equal to the item(4).
- 6) The signal generator output level is the rating of effective radiated power(ERP).
- 7) The instrument settings used (RBW/ VBW) during ERP/ EIRP output power measurement are as Belows ;
  - Below 1GHz : RBW 3MHz, VBW 3MHz
  - Above 1GHz : RBW 3MHz, VBW 3MHz



## 4.4 Modulation Requirements.

### 4.4.1 Frequency response of the audio modulation circuit.

#### Test Set-up

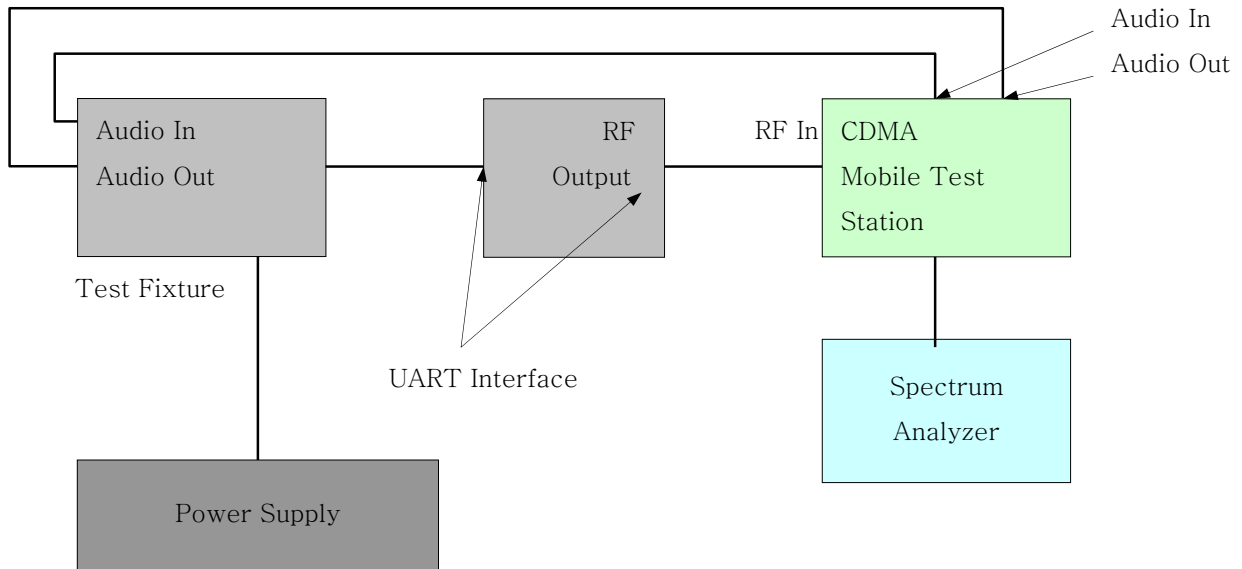

UART Interface: The UART Interface has a serial communication link that can be used to test , debug or upgrade the phone's functions and characteristics.

#### Test Procedure

- 1) Set the frequency deviation  $\pm 2.9\text{KHz}$  at the audio tone by adjusting the audio generator and record the demod out level at 1KHz.
- 2) Change the frequency of audio generator from 300KHz to 3000Hz and record the demod out level relative to the level at 1KHz.
- 3) Adjust the audio input frequency to 1000KHz and adjust the input level to 20dB greater than that required to produce  $\pm 8\text{KHz}$  deviation.
- 4) Change the frequency of audio generator from 3000Hz to 30,000Hz and record the demod out level relative to the level at 1KHz.

## 4.4.2 Modulation levels and response of modulation limiting circuitry.

### Test Set-up

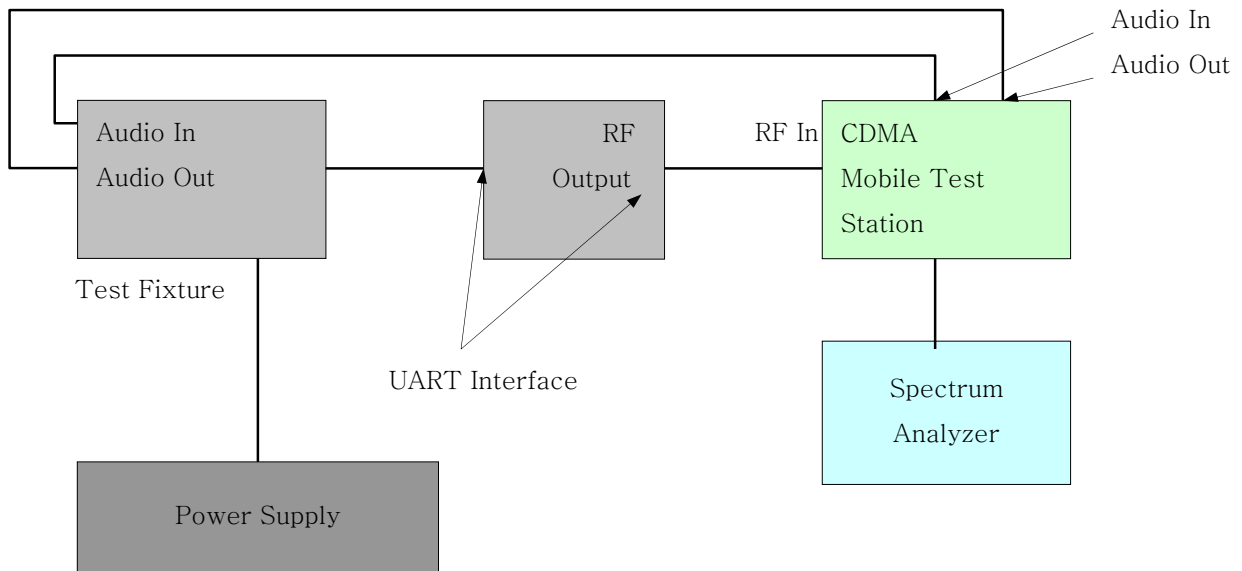

UART Interface: The UART Interface has a serial communication link that can be used to test , debug or upgrade the phone's functions and characteristics.

### Test Procedure

- 1) Set the frequency deviation  $\pm 7.2\text{KHz}$  at the audio tone by adjusting the audio generator. This level will be the 0 dB reference.
- 2) Increase the audio level from 0 dB reference to 30 dB in increments of 5 dB and record the frequency deviation.
- 3) This measurement is then repeated at 300Hz, 500Hz, 2000Hz and 3000Hz audio tone.

### 4.4.3 Levels of modulating signals.

#### Test Set-up

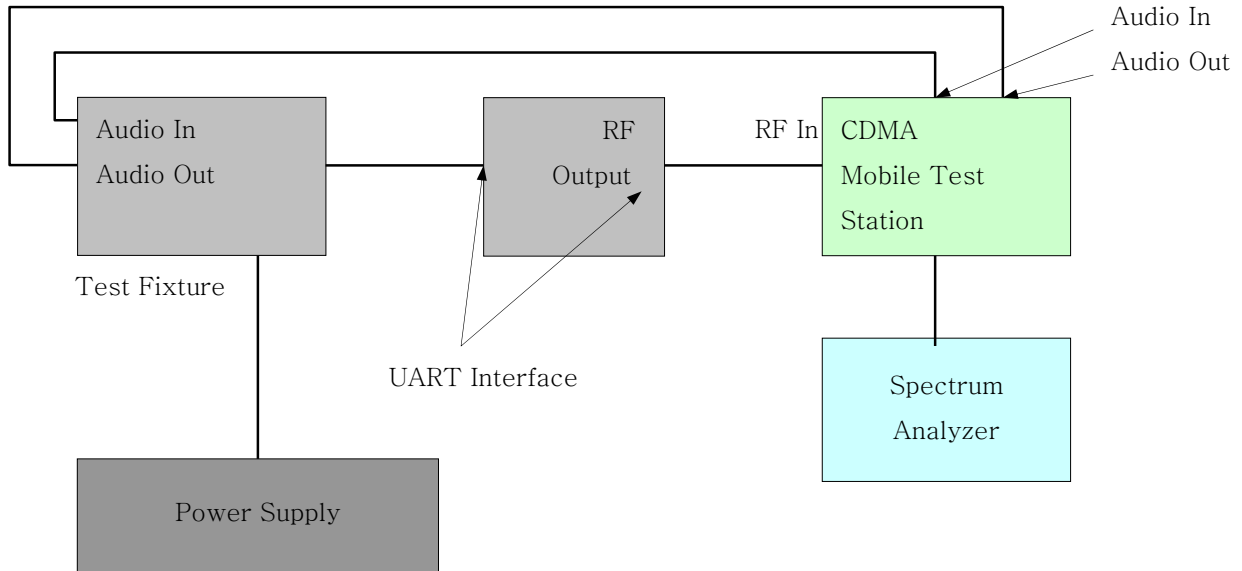

UART Interface: The UART Interface has a serial communication link that can be used to test , debug or upgrade the phone's functions and characteristics.

#### Test Procedure

- 1) Select the supervisory audio tone test mode pursuant to "Tune – up procedure" and record the frequency deviation on the modulation analyzer.
- 2) Select the signalling tone test mode pursuant to "Tune – up procedure" and record the frequency deviation on the modulation analyzer.
- 3) Select the TX data test mode pursuant to "Tune – up procedure" and record the frequency deviation on the modulation analyzer .

#### 4.4.4 Occupied bandwidth.

##### Test Set-up

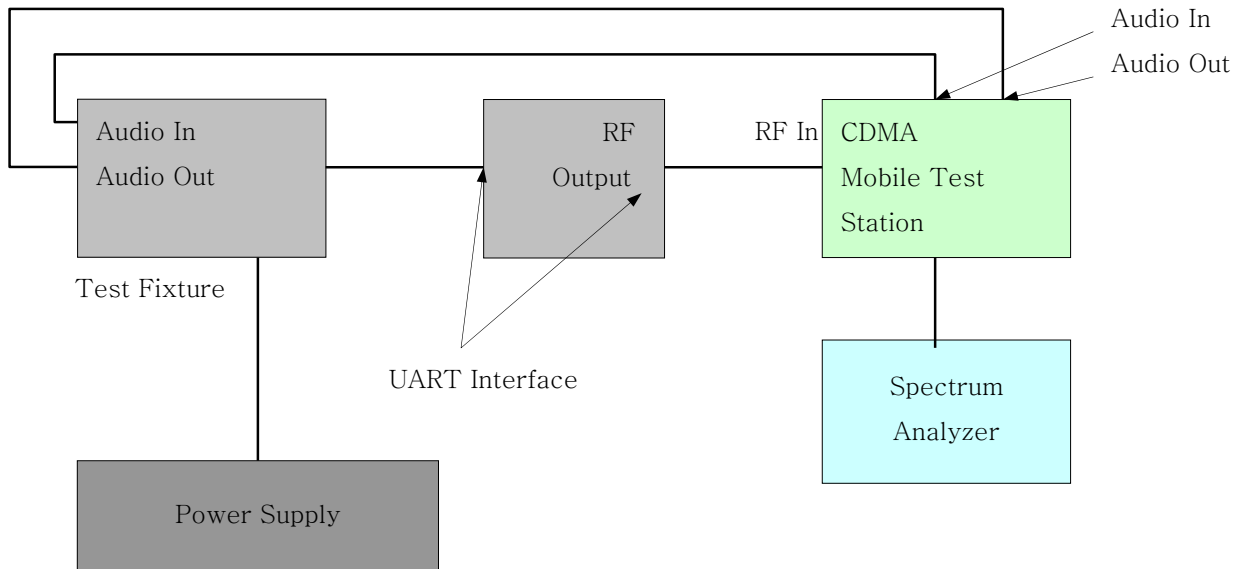

UART Interface: The UART Interface has a serial communication link that can be used to test , debug or upgrade the phone's functions and characteristics.

##### Test Procedure

1. F3E radiotelephony mode.
  - 1) The audio generator is set on the frequency of maximum audio response of the audio modulating circuit and its level adjusted for 50% modulation.
  - 2) Increase the audio level 16 dB greater than that necessary to produce 50 percent modulation and change the audio frequency to 2,500 Hz tone.
  - 3) The occupied bandwidth is drawn from the spectrum analyzer display.
2. F1D wideband data mode.
  - 1) Select the TX data test mode pursuant to "Tune-up procedure ".
  - 2) The occupied bandwidth is drawn from the spectrum analyzer display.
3. F3D supervisory audio tone mode.
  - 1) Select the supervisory tone test mode pursuant to "Tune-up procedure ".
  - 2) The occupied bandwidth is drawn from the spectrum analyzer display.
4. F3D signalling tone mode.
  - 1) Select the signalling audio tone test mode pursuant to "Tune-up procedure ".
  - 2) The occupied bandwidth is drawn from the spectrum analyzer display.

#### 4.4.5 Spurious and Harmonic Emissions at Antenna Terminal.

##### Test Set-up

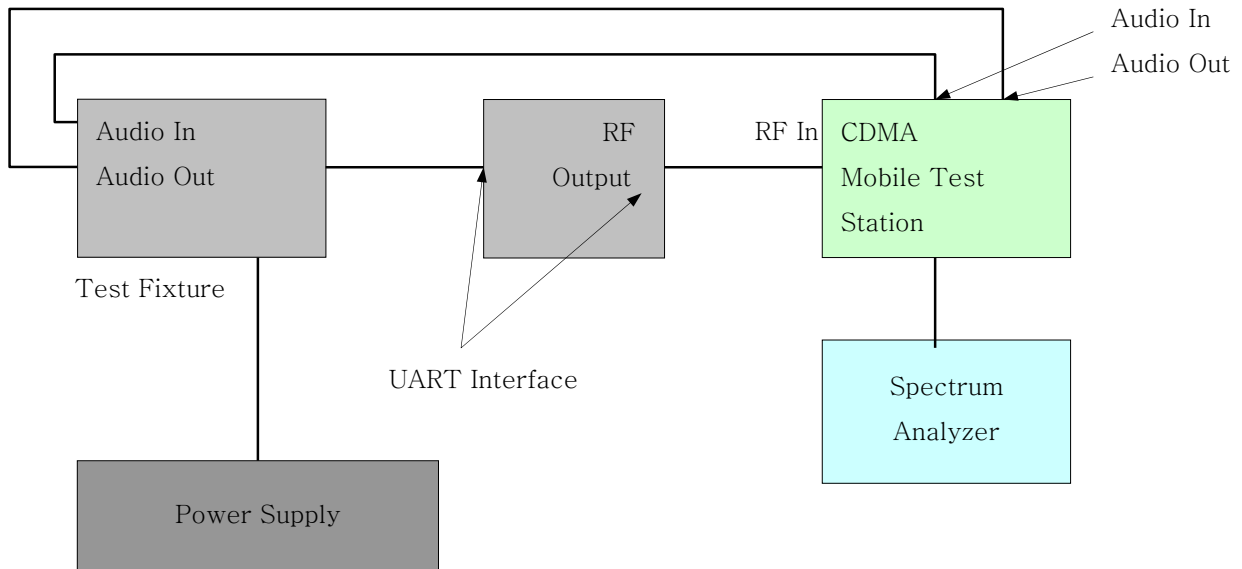

##### Test Procedure

The level of the carrier and the various conducted spurious and harmonic frequencies is measured by means of a calibrated spectrum analyzer. The spectrum is scanned from the lowest frequency generated in the equipment up to 10 GHz. The transmitter is modulated with a 2500Hz tone at a level of 16dB greater than that required to provide 50% modulation. At the input terminals of the spectrum analyzer, an isolator (RF circulator with one port terminated with 50 ohms) and an 870 MHz to 890 MHz bandpass filter is connected between the test transceiver (for conducted tests) or the receive antenna (for radiated tests) and the analyzer. The rejection of the bandpass filter to signals in the 825 — 845 MHz range is adequate to limit the transmit energy from the test transceiver which appears to a level which will allow the analyzer to measure signals less than —90dBm. Calibration of the test receiver is performed in the 870 — 890 MHz range to insure accuracy to allow variation in the bandpass filter insertion loss to be calibrated.

## 4.4.6 Field strength of spurious radiation .

### Test Set-up

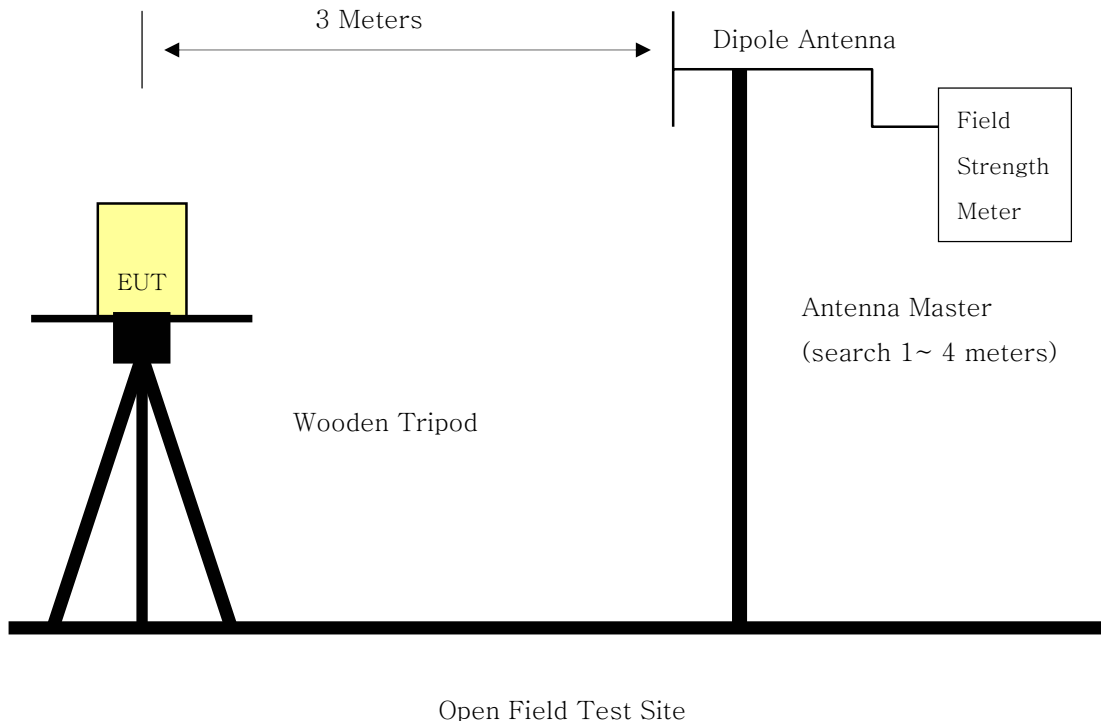

### Test Procedure

The measurement facilities used for this test have been documented in previous filings with the commission pursuant to section 2.948.

The open field test site is situated in open field with ground screen whose site attenuation characteristics meet ANSI C63.4 –1992. A mast capable of lifting the receiving antenna from a height of one to four meters is used together with a rotatable wooden platform mounted at three from the antenna mast.

- 1) The unit mounted on a wooden table  $1.5\text{m} \times 1.0\text{m} \times 0.80$  is 0.8 meter above test site ground level.
- 2) During the emission test , the turntable is rotated and the EUT is manipulated to find the configuration resulting in maximum emission under normal condition of installation and operation.
- 3) The antenna height and polarization are also varied from 1 to 4 meters until the maximum signal is found.
- 4) The spectrum shall be scanned up to the 10<sup>th</sup> harmonic of the fundamental frequency.
- 5) The instrument settings used (RBW/ VBW) during ERP/ EIRP output power measurement are as follows ;
  - Below 1GHz : RBW 100KHz, VBW 300KHz
  - Above 1GHz : RBW 3MHz, VBW 3MHz

## 4.4.7 Frequency stability .

### 4.4.7.1 Frequency stability with variation of ambient temperature.

#### Test Set-up

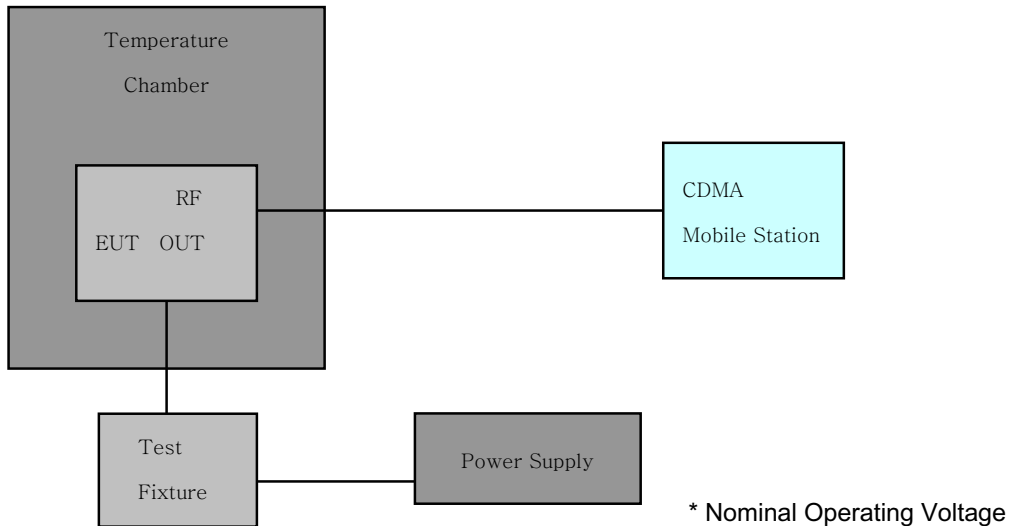

#### Test Procedure

The frequency stability of the transmitter is measured by:

- Temperature:** The temperature is varied from -30 °C to +60 °C using an environmental chamber.
- Primary Supply Voltage:** The primary supply voltage is varied from 85% to 115% of the voltage normally at the input to the device or at the power supply terminals if cables are not normally supplied.

Specification — The frequency stability shall be sufficient to ensure that the fundamental emission stays within the authorized frequency block. The frequency stability of the transmitter shall be maintained within  $\pm 0.0001$  ( $\pm 1$  ppm) of the center frequency.

#### Time Period and Procedure:

- The carrier frequency of the transmitter and the individual oscillators is measured at room temperature (25 °C to 27 °C to provide a reference).
- The equipment is subjected to an overnight "soak" at -30 °C without any power applied.
- After the overnight "soak" at 30 °C (usually 14-16 hours), the equipment is turned on in a "standby" condition for one minute before applying power to the transmitter. Measurement of the carrier frequency of the transmitter and the individual oscillators is made within a three minute interval after applying power to the transmitter.
- Frequency measurements are made at 10 °C interval up to room temperature. At least a period of one and one half-hour is provided to allow stabilization of the equipment at each temperature level.
- Again the transmitter carrier frequency and the individual oscillators is measured at room temperature to begin measurement of the upper temperature levels.
- Frequency were made at 10 intervals starting at 30 °C up to +50 °C allowing at least two hours at each temperature for stabilization. In all measurements the frequency is measured within three minutes after applying power to the transmitter.
- The artificial load is mounted external to the temperature chamber.

**NOTE: The EUT is tested down to the battery endpoint.**

#### 4.4.7.2 Frequency stability with variation of primary supply voltage.

##### Test Set-up

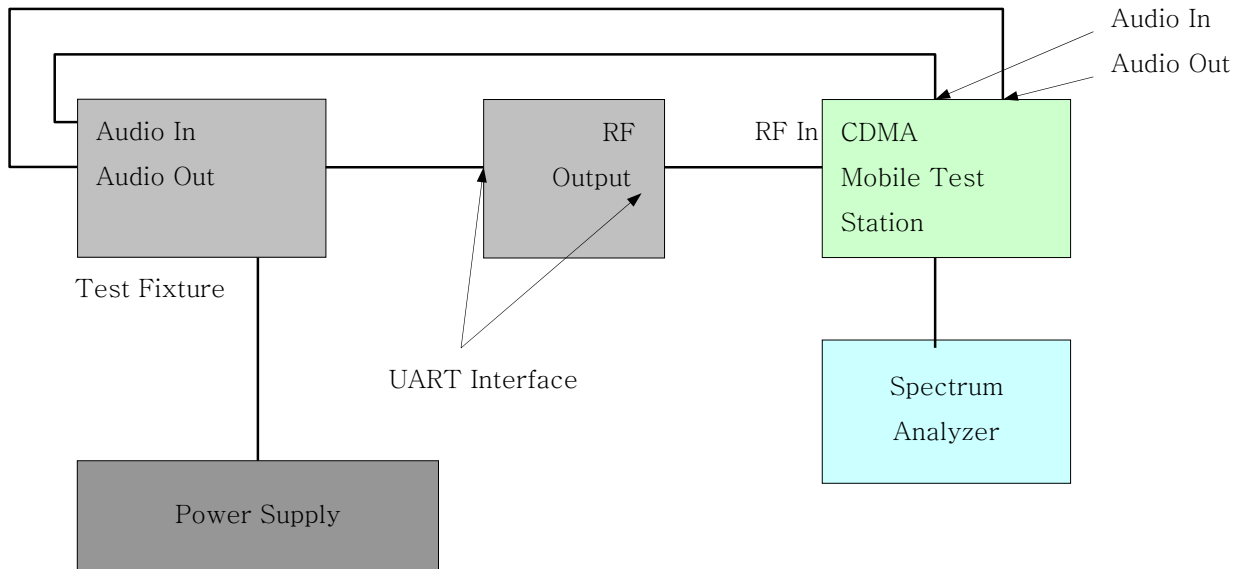

##### Test Procedure

- 1) The primary supply is varied in steps of 5% from 85 to 115% of the nominal supply voltage, or reduce primary supply voltage to the battery operating end point.
- 2) The frequency is recorded each 5% step.



## 5.1 Test Data (Continued)

## 5.2 Effective Radiated Power Output (CDMA)

### Radiated measurements at 3 meters

Modulation: CDMA

Freq. Tuned (MHz)	REF. LEVEL (dBm)	POL (H/V)	ERP (W)	ERP (dBm)	BATTERY
824.70	-22.6	V	0.282	24.5	Standard
835.89	-22.5	V	0.293	24.7	Standard
848.31	-22.8	V	0.274	24.4	Standard

Note: Standard batteries are the only options for this phone

#### NOTES:

Effective Radiated Power Output Measurements by Substitution Method  
according to ANSI/TIA/EIA-603-A-2001, Aug. 15, 2001:

The EUT was placed on a wooden turn table 3-meters from the receive antenna. The receive antenna height and turntable rotation was adjusted for the highest reading on the receive spectrum analyzer. For CDMA signals, a peak detector is used, with RBW=VBW=3MHz. For AMPS, GSM, and NADC TDMA signals, a peak detector is used, with RBW=VBW=1MHz. A Horn antenna was substituted in place of the EUT. This Horn antenna was driven by a signal generator and the level of the signal generator was adjusted to obtain the same receive spectrum analyzer reading. The conducted power at the terminals of the Horn antenna is measured. The difference between the gain of the horn and an isotropic antenna is taken into consideration and the EIRP is recorded.

## 6.1 Test Data (Continued)

### 6.1.1 CELLULAR CDMA Radiated Measurements

#### Field Strength of SPURIOUS Radiation

▣ OPERATING FREQUENCY:	_____	824.70 MHz
▣ CHANNEL:	_____	1013 (Low)
▣ MEASURED OUTPUT POWER:	_____	24.7dBm = 0.293 W
▣ MODULATION SIGNAL:	_____	CDMA (Internal)
▣ DISTANCE:	_____	3 meters
▣ LIMIT: $-(43 + 10 \log_{10} (W)) =$	_____	-37.67dBc

Freq. (MHz)	LEVEL@ ANTENNA TERMINALS (dBm)	SUBSTITUTE ANTENNA GAIN (dBd)	CORRECT GENERATOR LEVEL (dBm)	POL (H/V)	(dBc)
1649.40	-50.8	7.3	-43.5	V	-62.9
2474.10	-62.9	8.3	-54.6	V	-73.5
3298.80	-66.5	9.7	-56.8	V	-74.8

**NOTES:**

Radiated Spurious Emission Measurements by Substitution Method

according to ANSI/TIA/EIA-603-A-2001, Aug. 15, 2001:

The EUT was placed on a wooden turn table 3-meters from the receive antenna. The receive antenna height and turntable rotation was adjusted for the highest reading on the receive spectrum analyzer. For CDMA signals, a peak detector is used, with RBW=VBW=3MHz. For AMPS, GSM, and NADC TDMA signals, a peak detector is used, with RBW=VBW=1MHz. A half-wave dipole was substituted in place of the EUT. This dipole antenna was driven by a signal generator and the level of the signal generator was adjusted to obtain the same receive spectrum analyzer reading. This spurious level is recorded. For readings above 1GHz, the above procedure is repeated using horn antennas and the difference between the gain of the horn and an isotropic or dipole antenna are taken into consideration.

## 6.1 Test Data (Continued)

### 6.1.2 CELLULAR CDMA Radiated Measurements

#### Field Strength of SPURIOUS Radiation

▣ OPERATING FREQUENCY:	_____	835.89 MHz
▣ CHANNEL:	_____	0363 (Mid)
▣ MEASURED OUTPUT POWER:	_____	24.7dBm = 0.293 W
▣ MODULATION SIGNAL:	_____	CDMA (Internal)
▣ DISTANCE:	_____	3 meters
▣ LIMIT: $-(43 + 10 \log_{10} (W)) =$	_____	-37.67dBc

Freq. (MHz)	LEVEL@ ANTENNA TERMINALS (dBm)	SUBSTITUTE ANTENNA GAIN (dBd)	CORRECT GENERATOR LEVEL (dBm)	POL (H/V)	(dBc)
1671.78	-52.9	7.3	-45.6	V	-65.0
2507.67	-62.1	8.3	-53.8	V	-72.7
3343.56	-66.9	9.7	-57.2	V	-75.2

**NOTES:**

Radiated Spurious Emission Measurements by Substitution Method

according to ANSI/TIA/EIA-603-A-2001, Aug. 15, 2001:

The EUT was placed on a wooden turn table 3-meters from the receive antenna. The receive antenna height and turntable rotation was adjusted for the highest reading on the receive spectrum analyzer. For CDMA signals, a peak detector is used, with RBW=VBW=3MHz. For AMPS, GSM, and NADC TDMA signals, a peak detector is used, with RBW=VBW=1MHz. A half-wave dipole was substituted in place of the EUT. This dipole antenna was driven by a signal generator and the level of the signal generator was adjusted to obtain the same receive spectrum analyzer reading. This spurious level is recorded. For readings above 1GHz, the above procedure is repeated using horn antennas and the difference between the gain of the horn and an isotropic or dipole antenna are taken into consideration.

## 6.1 Test Data (Continued)

### 6.1.3 CELLULAR CDMA Radiated Measurements

#### Field Strength of SPURIOUS Radiation

- ▣ OPERATING FREQUENCY: 848.31 MHz
- ▣ CHANNEL: 0777 (High)
- ▣ MEASURED OUTPUT POWER: 24.7dBm = 0.293 W
- ▣ MODULATION SIGNAL: CDMA (Internal)
- ▣ DISTANCE: 3 meters
- ▣ LIMIT:  $-(43 + 10 \log_{10} (W)) =$  -37.67dBc

Freq. (MHz)	LEVEL@ ANTENNA TERMINALS (dBm)	SUBSTITUTE ANTENNA GAIN (dBd)	CORRECT GENERATOR LEVEL (dBm)	POL (H/V)	(dBc)
1696.62	-51.6	7.3	-44.3	V	-63.7
2544.93	-61.0	8.3	-52.7	V	-71.6
3393.24	-67.3	9.7	-57.6	V	-75.6

**NOTES:**

Radiated Spurious Emission Measurements by Substitution Method

according to ANSI/TIA/EIA-603-A-2001, Aug. 15, 2001:

The EUT was placed on a wooden turn table 3-meters from the receive antenna. The receive antenna height and turntable rotation was adjusted for the highest reading on the receive spectrum analyzer. For CDMA signals, a peak detector is used, with RBW=VBW=3MHz. For AMPS, GSM, and NADC TDMA signals, a peak detector is used, with RBW=VBW=1MHz. A half-wave dipole was substituted in place of the EUT. This dipole antenna was driven by a signal generator and the level of the signal generator was adjusted to obtain the same receive spectrum analyzer reading. This spurious level is recorded. For readings above 1GHz, the above procedure is repeated using horn antennas and the difference between the gain of the horn and an isotropic or dipole antenna are taken into consideration.

## 7.1 Test Data

### 7.1 FREQUENCY STABILITY (CDMA)

OPERATING FREQUENCY: 835.890.043 Hz  
 CHANNEL: 363  
 REFERENCE VOLTAGE: 115 VAC  
 DEVIATION LIM IT: ± 0.00025 % or 2.5 ppm

Voltage (%)	Power (VDC)	Temp. (°C)	Frequency (Hz)	Deviation (%)	Deviation (ppm)
100	115	+20 (Ref)	835,890,043	0.000000	0.00000
100		-30	835,890,029	0.000002	0.01675
100		-20	835,890,034	0.000001	0.01077
100		-10	835,890,021	0.000003	0.02632
100		0	835,890,036	0.000001	0.00837
100		+10	835,890,021	0.000003	0.02632
100		+20	835,890,028	0.000002	0.01794
100		+30	835,890,024	0.000002	0.02273
100		+40	835,890,042	0.000000	0.00120
100		+50	835,890,019	0.000003	0.02871
100		+60	835,890,022	0.000003	0.02512
85		97.75	+20	835,890,024	0.000002
115	132.25	+20	835,890,038	0.000001	0.00598
BATT.END POINT	N/A	+20	835,890,036	0.000001	0.00837

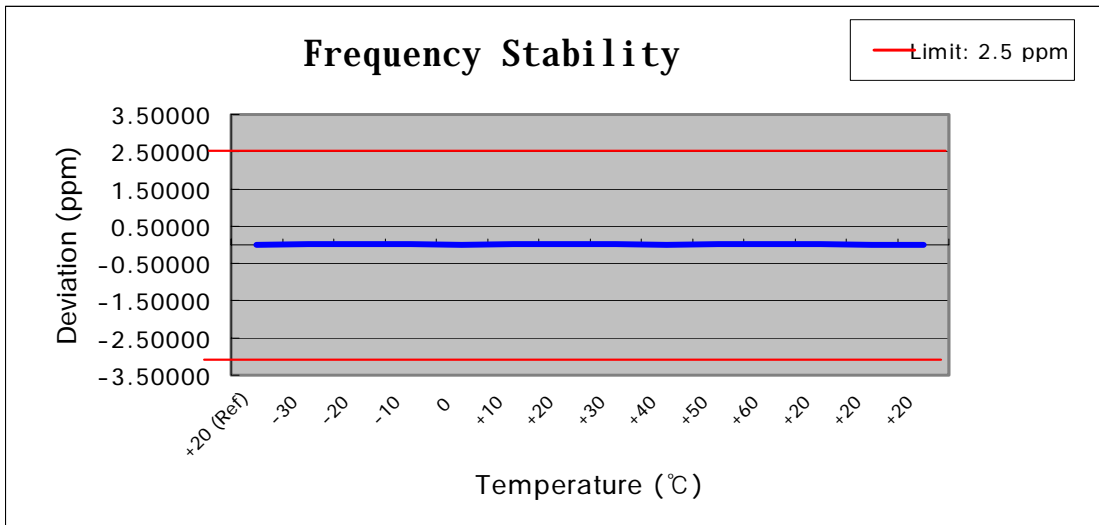

## 8.1 PLOT(S) OF EMISSION

---

(SEE ATTACHMENT D)

## 9.1 LIST OF TEST EQUIPMENT

Type / Model	Calib. Date	S/N
Spectrum Analyzer (20Hz~40GHz) R&S ESI40	Dec. 05	1088.7410
Spectrum Analyzer(100Hz~26.5GHz) R3273	April 06	J04821
Signal Generator HP8373ED (10MHz ~ 20GHz)	July 06	US8710152
Signal Generator MARCONI(10kHz ~ 2.7GHz)	Sep. 05	119331
Power Meter(A) HP 438A	July 06	2822A05909
Power Sensor(A) HP8481B	July 06	3318A08777
Power Meter(B) HP 438A	Nov. 05	2427A00963
Power Sensor(B) HP8481A	Oct. 05	2349A37617
Power Amp A0825-4343-R(800~2.5GHz) +43dB	Sep. 05	A00450
Network Analyzer HP-8753D (30kHz ~ 3GHz)	Sep. 05	3401J02111
Modulation Analyzer HP8901A	June 06	3438A05231
Dipole Antenna UHAP	June 06	557
Dipole Antenna UHAP	June 06	558
AMF-4D-001180-26-10P(0.1~18GHz)	Feb.06	671009
AMF-4D-001180-26-10P(18~26.5GHz)	Feb.06	667624
AMF-4D-001180-26-10P(26~40GHz)	Feb.06	671314
Audio Analyzer HP 8903A	Feb.06	2433A04322
Function Generator HP 8116A	Feb.06	3001A08285
Horn Antenna BBHA 9120D(1~18GHz)	June 06	1099
Horn Antenna BBHA 9120D(1~18GHz)	March 06	1201
Horn Antenna BBHA 9170(15~40GHz)	Feb.06	BBHA9170124
CDMA Mobile Station Test Set HP8924C	June 06	US39063847
PCS Interface HP83236B 1.7 ~ 2.0GHz	June 06	3711J04841
EMI Test Receiver Rohde & Schwarz ESH3	June 06	335.8017
EMI Test Receiver Rohde & Schwarz ESVP	Feb. 06	354.3000
EMI Test Receiver Rohde & Schwarz ESVS30	June 06	826006/013
Spectrum Analyzer HP 8591EM	July 06	3509A00155
LISN EMCO 3825/2	July 06	9706-1070
LISN Rohde & Schwarz ESH2-Z5	July 06	9706-1071
Amplifier Hewlett-Packard 8447E	March 06	2805A03141
Biconical Antenna BBA-9106(30~1000MHz)	June 06	D6901
Log-Periodic Antenna UHALP-9107(300~1000MHz)	June 06	91071107
Antenna VULB9160 (25MHz~1800MHz)	June 06	91071107
Antenna Position Tower HD240	N.A	3241
Turn Table EMCO 1060-06	N.A	1253A
AC Power Source PACIFIC Magnetic Module	N.A	45321
AC Power Source PACIFIC 360AMX	N.A	22B87

## 10.1 SAMPLE CALCULATIONS

### A. ERP Sample Calculation

Freq. Tuned (MHz)	LEVEL(1) (dBm)	POL (H/V)	ERP (W)	ERP(2) (dBm)	BATTERY
824.70	-29.73	H	0.346	25.393	Standard

- 1) The EUT mounted on a wooden tripod is 0.8 meter above test site ground level.
- 2) During the test , the turn table is rotated and the antenna height is also varied from 1 to 4 meters until the maximum signal is found.
- 3) Record the field strength meter's level.(LEVEL)
- 4) Replace the EUT with dipole antenna that is connected to a calibrated signal generator.
- 5) Increase the signal generator output till the field strength meter's level is equal to the item(3).
- 6) The signal generator output level with cable loss is the rating of effective radiated power(ERP).  
(Cable loss means the factor between Signal Generator and Transmitting Antenna.)

For more details, please refer to the test set-up procedure.

### B. Emission Designator

**Emission Designator = 1M25F9W**

CDMA BW = 1.25 MHz

F = Frequency Modulation

9 = Composite Digital Info

W = Combination (Audio/Data)

(Measured at the 99.75% power bandwidth)



## 11.1 CONCLUSION

---

The data collected shows that the Fixed WLL Telephone (CDMA) **FCC ID: PH7PX220** complies with all the requirements of Parts 2 and 22 of the FCC rules.

**Maximum Power Output table for PX220**

Band	Channel	S02	S02	S055	S055	TDSOS032
		RC1/1	RC3/3	RC1/1	RC3/3	RC3/3
CDMA	1013	24.05	24.01	24.02	24.02	24.01
	363	24.02	24.06	24.01	24.00	24.04
	777	24.04	24.05	23.99	24.02	23.98