



SAR TEST REPORT

HCT CO., LTD

EUT Type:	Cellular CDMA Wireless Gateway with WLAN		
FCC ID:	PH7MV420A		
Model:	MV420A	Trade Name	AXESSTEL
Date of Issue:	July 17, 2008		
Test report No.:	HCT-SAR08-0703		
Test Laboratory:	HCT CO., LTD. SAN 136-1, AMI-RI, BUBAL-EUP, ICHEON-SI, KYOUNGKI-DO, 467-701, KOREA TEL: +82 31 639 8565 FAX: +82 31 639 8525		
Applicant :	AXESSTEL INC. 6815 Flanders Drive Ste.210, San Diego, CA 92121 Tel: 858- 625-2100 Fax: 858- 625- 2110 E-Mail: dskim@axesstel.com		
Testing has been carried out in accordance with:	47CFR §2.1093 FCC OET Bulletin 65(Edition 97-01), Supplement C (Edition 01-01) ANSI/ IEEE C95.1 – 2005 IEEE 1528-2003		
Test result:	The tested device complies with the requirements in respect of all parameters subject to the test. The test results and statements relate only to the items tested. The test report shall not be reproduced except in full, without written approval of the laboratory.		
Signature	 _____ Report prepared by : Sun-Hee Kim Test Engineer of SAR Part	 _____ Approved by : Nam-Wook Kang Manager of SAR Part	

Table of Contents

<u>1. INTRODUCTION</u>	3
<u>2. DESCRIPTION OF DEVICE</u>	4
<u>3. DESCRIPTION OF TEST EQUIPMENT</u>	5
<u>3.1 SAR MEASUREMENT SETUP</u>	5
<u>3.2 DASY E-FIELD PROBE SYSTEM</u>	6
<u>3.3 PROBE CALIBRATION PROCESS</u>	7
<u>3.4 SAM Phantom</u>	9
<u>3.5 Device Holder for Transmitters</u>	9
<u>3.6 Brain & Muscle Simulating Mixture Characterization</u>	10
<u>3.7 SAR TEST EQUIPMENT</u>	11
<u>4. SAR MEASUREMENT PROCEDURE</u>	12
<u>5. DESCRIPTION OF TEST POSITION</u>	13
<u>5.1 HEAD POSITION</u>	13
<u>5.2 Body Holster/Belt Clip Configurations</u>	14
<u>6. MEASUREMENT UNCERTAINTY</u>	15
<u>7. ANSI/ IEEE C95.1 - 2005 RF EXPOSURE LIMITS</u>	16
<u>8. SYSTEM VERIFICATION</u>	17
<u>8.1 Tissue Verification</u>	17
<u>8.2 System Validation</u>	17
<u>9. TEST CONFIGURATION</u>	18
<u>9.1 General Device Setup</u>	18
<u>9.2 Frequency Channel Configurations</u>	18
<u>10. 3G MEASUREMENT PROCEDURES</u>	19
<u>10.1 Procedures Used To Establish Test Signal</u>	19
<u>10.2 SAR Measurement Conditions for CDMA2000 1x</u>	19
<u>11. SAR Evaluation Considerations for Handsets with Multiple Transmitters and Antennas</u>	21
<u>11.1 SAR Evaluation Considerations</u>	21
<u>12. SAR TEST DATA SUMMARY</u>	21
<u>12.1 Measurement Results (EVDO CDMA Body SAR)</u>	22
<u>12.2 Measurement Results (802.11b/g Module Body SAR)</u>	23
<u>13. CONCLUSION</u>	24
<u>14. REFERENCES</u>	25
Attachment 1. – SAR Test Plots	26
Attachment 2. – Dipole Validation Plots	41
Attachment 3. – Probe Calibration Data	50
Attachment 4. – Dipole Calibration Da	60

1. INTRODUCTION

The FCC has adopted the guidelines for evaluating the environmental effects of radio frequency radiation in ET Docket 93-62 on Aug. 6, 1996 to protect the public and workers from the potential hazards of RF emissions due to FCC-regulated portable devices.

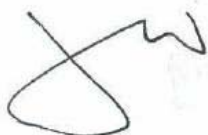
The safety limits used for the environmental evaluation measurements are based on the criteria published by the American National Standards Institute (ANSI) for localized specific absorption rate (SAR) in IEEE/ANSI C95.1-2005 Standard for Safety Levels with Respect to Human Exposure to Radio Frequency Electromagnetic Fields, 3 kHz to 300 GHz. 1992 by the Institute of Electrical and Electronics Engineers, Inc., New York, New York 10017. The measurement procedure described in IEEE/ANSI C95.3-1992 Recommended Practice for the Measurement of Potentially Hazardous Electromagnetic Fields - RF and Microwave is used for guidance in measuring SAR due to the RF radiation exposure from the Equipment Under Test (EUT). These criteria for SAR evaluation are similar to those recommended by the National Council on Radiation Protection and Measurements (NCRP) in Biological Effects and Exposure Criteria for Radio frequency Electromagnetic Fields," NCRP Report No. 86 NCRP, 1986, Bethesda, MD 20814. SAR is a measure of the rate of energy absorption due to exposure to an RF transmitting source. SAR values have been related to threshold levels for potential biological hazards.

SAR Definition

Specific Absorption Rate (SAR) is defined as the time derivative of the incremental electromagnetic energy (dW) absorbed by (dissipated in) an incremental mass (dm) contained in a volume element (dV) of a given density (r). It is also defined as the rate of RF energy absorption per unit mass at a point in an absorbing body.

$$SAR = \frac{d}{dt} \left(\frac{dU}{dm} \right) = \frac{d}{dt} \left(\frac{dU}{\rho dV} \right)$$

Figure 2. SAR Mathematical Equation

SAR is expressed in units of Watts per Kilogram (W/kg).

$$SAR = \sigma E^2 / \rho$$

where:

- σ = conductivity of the tissue-simulant material (S/m)
- ρ = mass density of the tissue-simulant material (kg/m³)
- E = Total RMS electric field strength (V/m)

NOTE: The primary factors that control rate of energy absorption were found to be the wavelength of the incident field in relations to the dimensions and geometry of the irradiated organism, the orientation of the organism in relation to the polarity of field vectors, the presence of reflecting surfaces, and whether conductive contact is made by the organism with a ground plane.

2. DESCRIPTION OF DEVICE

Environmental evaluation measurements of specific absorption rate (SAR) distributions in emulated human head and body tissues exposed to radio frequency (RF) radiation from wireless portable devices for compliance with the rules and regulations of the U.S. Federal Communications Commission (FCC).

EUT Type	Cellular CDMA Wireless Gateway with WLAN
FCC ID	PH7MV420A
Model(s)	MV420A
Trade Name	AXESSTEL
Serial Number(s)	#1
Application Type	Certification
Modulation(s)	CDMA/DSSS/OFDM
Tx Frequency	824.70 - 848.31 MHz (CDMA) 2 412- 2 462 MHz (DSSS/ OFDM)
Rx Frequency	869.70 - 893.31 MHz (CDMA) 2 412- 2 462 MHz (DSSS/ OFDM)
FCC Classification	Licensed Non-Broadcast station Transmitter - TNB
Production Unit or Identical Prototype	Prototype
Max SAR	0.731 W/kg CDMA Body SAR (EVDO) 0.444 W/kg Wi-Fi 802.11b 0.246 W/kg Wi-Fi 802.11g
Date(s) of Tests	July 14~16, 2008
Antenna Type	Removable

3. DESCRIPTION OF TEST EQUIPMENT

3.1 SAR MEASUREMENT SETUP

These measurements are performed using the DASY4 automated dosimetric assessment system. It is made by Schmid & Partner Engineering AG (SPEAG) in Zurich, Switzerland. It consists of high precision robotics system (Staubli), robot controller, Pentium III computer, near-field probe, probe alignment sensor, and the generic twin phantom containing the brain equivalent material. The robot is a six-axis industrial robot performing precise movements to position the probe to the location (points) of maximum electromagnetic field (EMF) (see Figure.3.1).

A cell controller system contains the power supply, robot controller, teach pendant (Joystick), and remote control, is used to drive the robot motors. The PC consists of the HP Pentium IV 3.0 GHz computer with Windows XP system and SAR Measurement Software DASY4, A/D interface card, monitor, mouse, and keyboard. The Staubli Robot is connected to the cell controller to allow software manipulation of the robot. A data acquisition electronic (DAE) circuit performs the signal amplification, signal multiplexing, AD-conversion, offset measurements, mechanical surface detection, collision detection, etc. is connected to the Electro-optical coupler (EOC). The EOC performs the conversion from the optical into digital electric signal of the DAE and transfers data to the PC plug-in card.

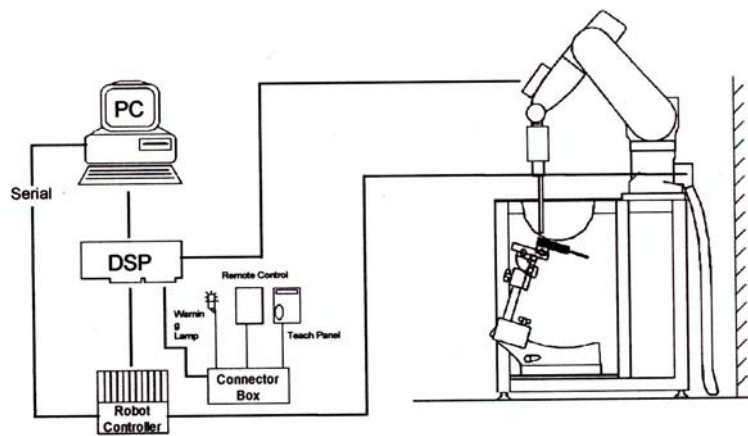

Figure 3.1 HCT SAR Lab. Test Measurement Set-up

The DAE4 consists of a highly sensitive electrometer-grade preamplifier with auto-zeroing, a channel and gain-switching multiplexer, a fast 16 bit AD-converter and a command decoder and control logic unit. Transmission to the PC-card is accomplished through an optical downlink for data and status information and an optical uplink for commands and clock lines. The mechanical probe mounting device includes two different sensor systems for frontal and sidewise probe contacts. They are also used for mechanical surface detection and probe collision detection. The robot uses its own controller with a built in VME-bus computer. The system is described in detail in.

3.2 DASY E-FIELD PROBE SYSTEM

3.2.1 ET3DV6 Probe Specification

Construction	Symmetrical design with triangular core Built-in optical fiber for surface detection System Built-in shielding against static charges
Calibration	In air from 10 MHz to 2.3 GHz In brain and muscle simulating tissue at Frequencies of 450 MHz, 900 MHz and 1.8 GHz (accuracy: 8 %)
Frequency	10 MHz to > 2.3 GHz; Linearity: ± 0.2 dB (30 MHz to 3 GHz)
Directivity	± 0.2 dB in brain tissue (rotation around probe axis) ± 0.4 dB in brain tissue (rotation normal probe axis)
Dynamic Range	5 μ W/g to > 100 mW/g; Linearity : ± 0.2 dB
Optical Surface Detection	± 0.2 mm repeatability in air and clear liquids over diffuse reflecting surfaces.
Dimensions	Overall length: 330 mm Tip length: 16 mm Body diameter: 12 mm Tip diameter: 6.8 mm Distance from probe tip to dipole centers: 2.7 mm
Application	General dissymmetry up to 3 GHz Compliance tests of mobile phones Fast automatic scanning in arbitrary phantoms

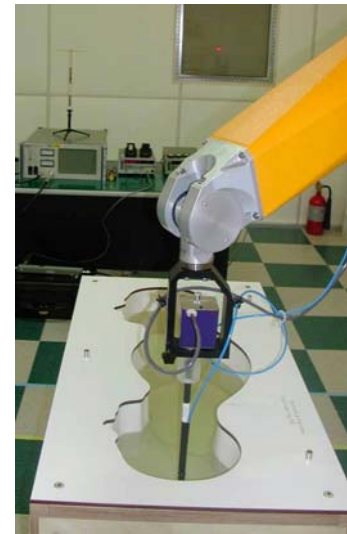

Figure 3.2 Photograph of the probe and the Phantom



Figure 3.3 ET3DV6 E-field Probe

The SAR measurements were conducted with the dosimetric probe ET3DV6, designed in the classical triangular configuration and optimized for dosimetric evaluation. The probe is constructed using the thick film technique; with printed resistive lines on ceramic substrates. The probe is equipped with an optical multifiber line ending at the front of the probe tip. It is connected to the EOC box on the robot arm and provides an automatic detection of the phantom surface. Half of the fibers are connected to a pulsed infrared transmitter, the other half to a synchronized receiver. As the probe approaches the surface, the reflection from the surface produces a coupling from the transmitting to the receiving fibers. This reflection increases first during the approach, reaches a maximum and then decreases. If the probe is flatly touching the surface, the coupling is zero. The distance of the coupling maximum to the surface is independent of the surface reflectivity and largely independent of the surface to probe angle. The DASY4 software reads the reflection during a software approach and looks for the maximum using a 2nd order fitting. The approach is stopped at reaching the maximum.

3.3 PROBE CALIBRATION PROCESS

3.3.1 E-Probe Calibration

Each probe is calibrated according to a dosimetric assessment procedure with an accuracy better than ± 10 %. The spherical isotropy was evaluated with the proper procedure and found to be better than ± 0.25 dB. The sensitivity parameters (NormX, NormY, NormZ), the diode compression parameter (DCP) and the conversion factor (ConvF) of the probe is tested.

The free space E-field from amplified probe outputs is determined in a test chamber. This is performed in a TEM cell for frequencies below 1 GHz, and in a waveguide above 1 GHz for free space. For the free space calibration, the probe is placed in the volumetric center of the cavity and at the proper orientation with the field. The probe is then rotated 360 degrees.

E-field temperature correlation calibration is performed in a flat phantom filled with the appropriate simulated brain tissue. The measured free space E-field in the medium correlates to temperature rise in a dielectric medium. For temperature correlation calibration a RF transparent thermistor-based temperature probe is used in conjunction with the E-field probe.

$$SAR = C \frac{\Delta T}{\Delta t}$$

where:

- Δt = exposure time (30 seconds),
- C = heat capacity of tissue (brain or muscle),
- ΔT = temperature increase due to RF exposure.

SAR is proportional to $\Delta T / \Delta t$, the initial rate of tissue heating, before thermal diffusion takes place. Now it's possible to quantify the electric field in the simulated tissue by equating the thermally derived SAR to the E- field;

$$SAR = \frac{|E|^2 \cdot \sigma}{\rho}$$

where:

- σ = simulated tissue conductivity,
- ρ = Tissue density (1.25 g/cm³ for brain tissue)

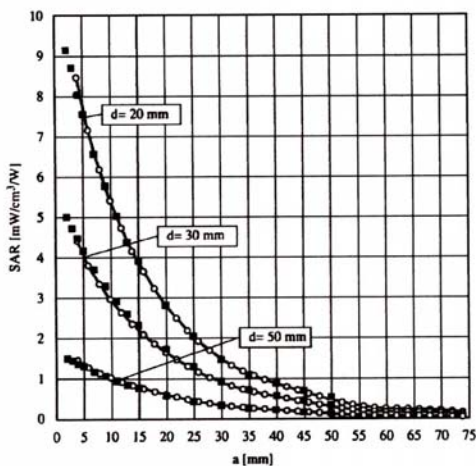

Figure 3.4 E-Field and Temperature measurements at 900 MHz

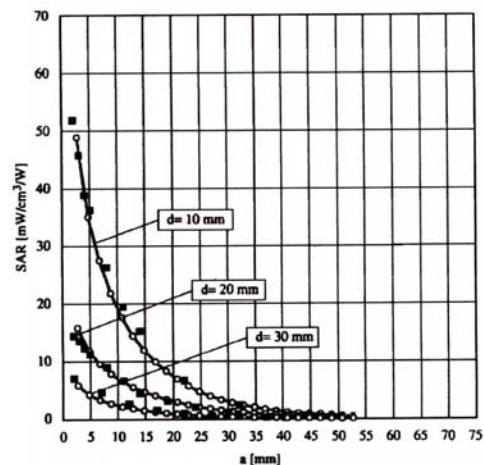

Figure 3.5 E-Field and temperature measurements at 1.8 GHz

3.3.2 Data Extrapolation

The DASY4 software automatically executes the following procedures to calculate the field units from the microvolt readings at the probe connector. The first step of the evaluation is a linearization of the filtered input signal to account for the compression characteristics of the detector diode. The compensation depends on the input signal, the diode type and the DC-transmission factor from the diode to the evaluation electronics. If the exciting field is pulsed, the crest factor of the signal must be known to correctly compensate for peak power. The formula for each channel can be given like below;

$$V_i = U_i + U_i^2 \cdot \frac{cf}{dcp_i}$$

with V_i = compensated signal of channel i (i=x,y,z)
 U_i = input signal of channel i (i=x,y,z)
 cf = crest factor of exciting field (DASY parameter)
 dcp_i = diode compression point (DASY parameter)

From the compensated input signals the primary field data for each channel can be evaluated:

E-field probes:

$$E_i = \sqrt{\frac{V_i}{Norm_i \cdot ConvF}}$$

with V_i = compensated signal of channel i (i = x,y,z)
 $Norm_i$ = sensor sensitivity of channel i (i = x,y,z)
 $\mu V/(V/m)^2$ for E-field probes
 $ConvF$ = sensitivity of enhancement in solution
 E_i = electric field strength of channel i in V/m

The RSS value of the field components gives the total field strength (Hermetian magnitude):

$$E_{tot} = \sqrt{E_x^2 + E_y^2 + E_z^2}$$

The primary field data are used to calculate the derived field units.

$$SAR = E_{tot}^2 \cdot \frac{\sigma}{\rho \cdot 1000}$$

with SAR = local specific absorption rate in W/g
 E_{tot} = total field strength in V/m
 σ = conductivity in [mho/m] or [Siemens/m]
 ρ = equivalent tissue density in g/cm³

The power flow density is calculated assuming the excitation field to be a free space field.

$$P_{pwe} = \frac{E_{tot}^2}{3770}$$

with P_{pwe} = equivalent power density of a plane wave in W/cm²
 E_{tot} = total electric field strength in V/m

3.4 SAM Phantom

The SAM Phantom is constructed of a fiberglass shell integrated in a wooden table. The shape of the shell is based on data from an anatomical study designed to determine the maximum exposure in at least 90 % of all users. It enables the dosimetric evaluation of left and right hand phone usage as well as body mounted usage at the flat phantom region. A cover prevents the evaporation of the liquid. Reference markings on the Phantom allow the complete setup of all predefined phantom positions and measurement grids by manually teaching three points in the robot.

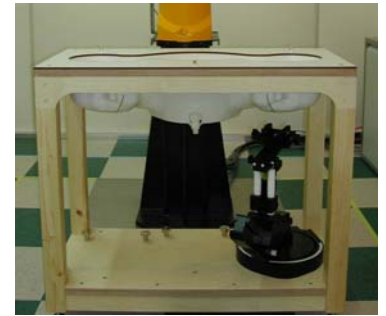

Figure 3.6 SAM Phantom

Shell Thickness	2.0 mm
Filling Volume	about 30 L
Dimensions	810 mm x 1 000 mm x 500 mm (H x L x W)

3.5 Device Holder for Transmitters

In combination with the SAM Phantom V 4.0, the Mounting Device (POM) enables the rotation of the mounted transmitter in spherical coordinates whereby the rotation points is the ear opening. The devices can be easily, accurately, and repeatably positioned according to the FCC and CENELEC specifications. The device holder can be locked at different phantom locations (left head, right head, flat phantom).

Note: A simulating human hand is not used due to the complex anatomical and geometrical structure of the hand that may produce an infinite number of configurations. To produce the Worst-case condition (the hand absorbs antenna output power), the hand is omitted during the tests.



Figure 3.7 Device Holder

3.6 Brain & Muscle Simulating Mixture Characterization

The brain and muscle mixtures consist of a viscous gel using hydrox-ethyl cellulose (HEC) gelling agent and saline solution (see Table 3.1). Preservation with a bactericide is added and visual inspection is made to make sure air bubbles are not trapped during the mixing process. The mixture is calibrated to obtain proper dielectric constant (permittivity) and conductivity of the desired tissue. The mixture characterizations used for the brain and muscle tissue simulating liquids are according to the data by C. Gabriel and G. Hartsgrove.

Ingredients (% by weight)	Frequency (MHz)									
	450		835		915		1 900		2 450	
Tissue Type	Head	Body	Head	Body	Head	Body	Head	Body	Head	Body
Water	38.56	51.16	41.45	52.4	41.05	56.0	54.9	40.4	62.7	73.2
Salt (NaCl)	3.95	1.49	1.45	1.4	1.35	0.76	0.18	0.5	0.5	0.04
Sugar	56.32	46.78	56.0	45.0	56.5	41.76	0.0	58.0	0.0	0.0
HEC	0.98	0.52	1.0	1.0	1.0	1.21	0.0	1.0	0.0	0.0
Bactericide	0.19	0.05	0.1	0.1	0.1	0.27	0.0	0.1	0.0	0.0
Triton X-100	0.0	0.0	0.0	0.0	0.0	0.0	0.0	0.0	36.8	0.0
DGBE	0.0	0.0	0.0	0.0	0.0	0.0	44.92	0.0	0.0	26.7

Salt:	99 % Pure Sodium Chloride	Sugar:	98 % Pure Sucrose
Water:	De-ionized, 16M resistivity	HEC:	Hydroxyethyl Cellulose
DGBE:	99 % Di(ethylene glycol) butyl ether,[2-(2-butoxyethoxy) ethanol]		
Triton X-100(ultra pure):	Polyethylene glycol mono[4-(1,1,3,3-tetramethylbutyl)phenyl] ether		

Table 3.1 Composition of the Tissue Equivalent Matter

3.7 SAR TEST EQUIPMENT

Manufacturer	Type / Model	S/N	Calib. Date	Calib.Interval	Calib.Due
SPEAG	SAM Phantom	-	N/A	N/A	N/A
Staubli	Robot RX90L	F01/5K09A1/A/01	N/A	N/A	N/A
Staubli	Robot ControllerCS7MB	F99/5A82A1/C/01	N/A	N/A	N/A
HP	Pavilion t000_puffer	KRJ51201TV	N/A	N/A	N/A
SPEAG	Light Alignment Sensor	265	N/A	N/A	N/A
Staubli	Teach Pendant (Joystick)	D221340.01	N/A	N/A	N/A
SPEAG	DAE4V1	447	Sep.13, 2007	Annual	Sep.13, 2008
SPEAG	E-Field Probe ET3DV6	1609	Aug.30, 2007	Annual	Aug.30, 2008
SPEAG	E-Field Probe ET3DV6	1798	Mar. 20, 2008	Annual	Mar. 20, 2009
SPEAG	Validation Dipole D835V2	441	May 19, 2008	Annual	May 19, 2009
SPEAG	Validation Dipole D1900V2	5d038	Nov.20, 2007	Annual	Nov.20, 2008
SPEAG	Validation Dipole D2450V2	734	Aug.20,2007	Annual	Aug.20,2008
Agilent	Power Meter(F) E4419B	MY41291386	Nov.05, 2007	Annual	Nov.05, 2008
Agilent	Power Sensor(G) 8481	MY41090870	Nov.05, 2007	Annual	Nov.05, 2008
HP	Dielectric Probe Kit 85070C	00721521	N/A	N/A	N/A
HP	Dual Directional Coupler	16072	Nov. 05, 2007	Annual	Nov. 05, 2008
R&S	Base Station CMU200	838207/050	Nov. 05, 2007	Annual	Nov. 05, 2008
Agilent	Base Station E5515C	GB44400269	Feb.10, 2008	Annual	Feb.10, 2009
HP	Signal Generator E4438C	MY42082646	Dec.24, 2007	Annual	Dec.24, 2008
HP	Network Analyzer 8753ES	JP39240221	Apr.11, 2008	Annual	Apr.11, 2009
EM POWER	Power Amp BBS3Q7ELU	1013-D/C-0127	Apr.12, 2008	Annual	Apr.12, 2009
Tescom	TC-3000/ Bluetooth	3000A4900112	Jan.11,2008	Annual	Jan.11,2009

NOTE:

The E-field probe was calibrated by SPEAG, by the waveguide technique procedure. Dipole Validation measurement is performed by HCT Lab. before each test. The brain simulating material is calibrated by HCT using the dielectric probe system and network analyzer to determine the conductivity and permittivity (dielectric constant) of the brain-equivalent material.

4. SAR MEASUREMENT PROCEDURE

The evaluation was performed with the following procedure:

1. The SAR value at a fixed location above the ear point was measured and was used as a reference value for assessing the power drop.
2. The SAR distribution at the exposed side of the head was measured at a distance of 3.9 mm from the inner surface of the shell. The area covered the entire dimension of the head and the horizontal grid spacing was 20 mm x 20 mm. Based on this data, the area of the maximum absorption was determined by spline interpolation.
3. Around this point, a volume of 32 mm x 32 mm x 34 mm was assessed by measuring 5 x 5 x 7 points. On this basis of this data set, the spatial peak SAR value was evaluated with the following procedure:
 - a. The data at the surface were extrapolated, since the center of the dipoles is 2.7 mm away from the tip of the probe and the distance between the surface and the lowest measuring point is 1.2 mm. The extrapolation was based on a least square algorithm. A polynomial of the fourth order was calculated through the points in z-axes. This polynomial was then used to evaluate the points between the surface and the probe tip.
 - b. The maximum interpolated value was searched with a straight-forward algorithm. Around this maximum the SAR values averaged over the spatial volumes (1 g or 10 g) were computed using the 3D-Spline interpolation algorithm. The 3D-spline is composed of three one-dimensional splines with the "Not a knot" condition (in x, y, and z directions. The volume was integrated with the trapezoidal algorithm. One thousand points (10 x 10 x 10) were interpolated to calculate the average.
 - c. All neighboring volumes were evaluated until no neighboring volume with a higher average value was found.
4. The SAR value, at the same location as procedure #1, was re-measured. If the value changed by more than 5 %, the evaluation is repeated.

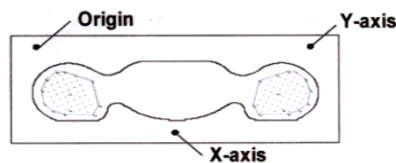

Figure 4.1 SAR Measurement Point in Area Scan

5. DESCRIPTION OF TEST POSITION

5.1 HEAD POSITION

The device was placed in a normal operating position with the Point A on the device, as illustrated in following drawing, aligned with the location of the RE(ERP) on the phantom. With the ear-piece pressed against the head, the vertical center line of the body of the handset was aligned with an imaginary plane consisting of the RE, LE and M. While maintaining these alignments, the body of the handset was gradually moved towards the cheek until any point on the mouth-piece or keypad contacted the cheek. This is a cheek/touch position. For ear/tilt position, while maintain the device aligned with the BM and FN lines, the device was pivot against ERP back for 15° or until the device antenna touch the phantom. Please refer to IEEE 1528-2003 illustration below.

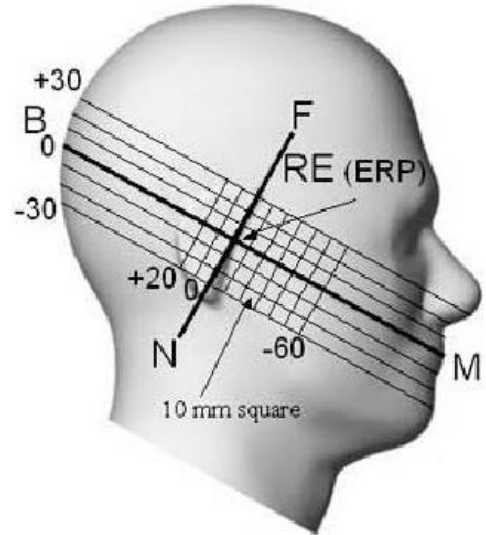

Figure 5.1 Side view of the phantom

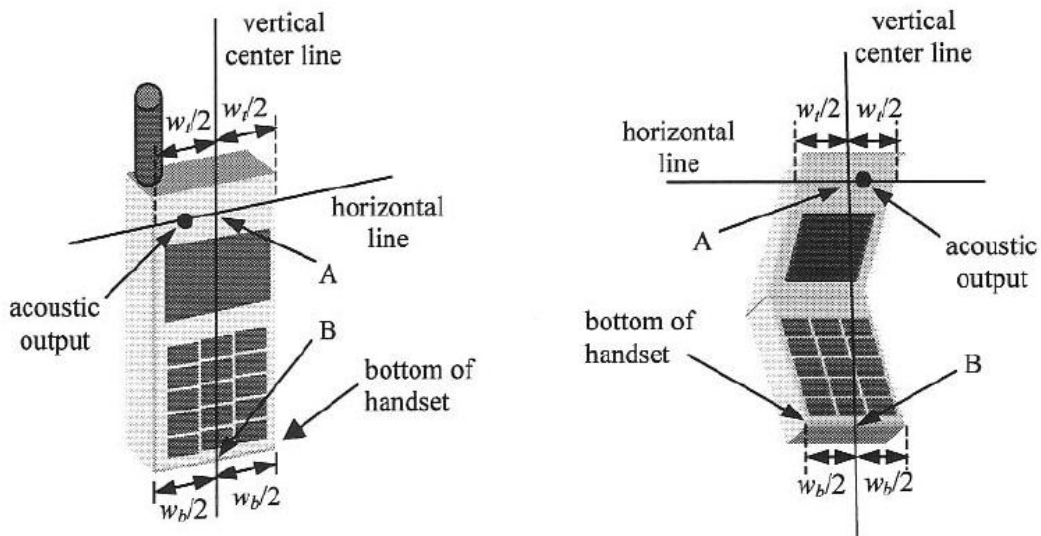

Figure 5.2 Handset vertical and horizontal reference lines

5.2 Body Holster/Belt Clip Configurations

Body-worn operating configurations are tested with the belt-clips and holsters attached to the device and positioned against a flat phantom in a normal use configuration. A device with a headset output is tested with a headset connected to the device. Body dielectric parameters are used.

Accessories for Body-worn operation configurations are divided into two categories: those that do not contain metallic components and those that contain metallic components. When multiple accessories that do not contain metallic components are supplied with the device, the device is tested with only the accessory that dictates the closest spacing to the body. Then multiple accessories that contain metallic components are tested with each accessory. If multiple accessory share an identical metallic component (i.e. the same metallic belt-clip used with different holsters with no other metallic components) only the accessory that dictates the closest spacing to the body is tested.

Body-worn accessories may not always be supplied or available as options for some Devices intended to be authorized for body-worn use. In this case, a test configuration with a separation distance between the back of the device and the flat phantom is used.

Since this EUT does not supply any body worn accessory to the end user a distance of 2.0 cm from the EUT back surface to the liquid interface is configured for the generic test.

"See the Test SET-UP Photo"

Transmitters that are designed to operate in front of a person's face, as in push-to-talk configurations, are tested for SAR compliance with the front of the device positioned to face the flat phantom. For devices that are carried next to the body such as a shoulder, waist or chest-worn transmitters, SAR compliance is tested with the accessory(ies), including headsets and microphones, attached to the device and positioned against a flat phantom in a normal use configuration.

In all cases SAR measurements are performed to investigate the worst-case positioning. Worstcase positioning is then documented and used to perform Body SAR testing.

6. MEASUREMENT UNCERTAINTY

Measurement uncertainties in SAR measurements are difficult to quantify due to several variables including biological, physiological, and environmental. However, we estimate the measurement uncertainties in SAR to be less than 15 % - 25 %.

According to ANSI/IEEE C95.3, the overall uncertainties are difficult to assess and will vary with the type of meter and usage situation. However, accuracy's of 1 dB to ± 3 dB can be expected in practice, with greater uncertainties in near-field situations and at higher frequencies (shorter wavelengths), or areas where large reflecting objects are present. Under optimum measurement conditions, SAR measurement uncertainties of at least ± 2 dB can be expected.

According to CENELEC, typical worst-case uncertainty of field measurements is 5 dB. For well-defined modulation characteristics the uncertainty can be reduced to ± 3 dB.

Error Description	Uncertainty value [%]	Probability Distribution	Divisor	ci	ci^2	Standard Uncertainty [%]	Stand Uncert^2	(Stand Uncert^2) X (ci^2)	Vi & Ve//
1. Measurement System									
Probe Calibration	5.5	Normal	1.00	1	1	5.50	30.25	30.25	∞
Axial Isotropy	4.7	Rectangular	1.73	0.7	0.49	2.71	7.36	3.61	∞
Hemispherical Isotropy	9.6	Rectangular	1.73	0.7	0.49	5.54	30.72	15.05	∞
Linearity	4.7	Rectangular	1.73	1	1	2.71	7.36	7.36	∞
System Detection limits	1.0	Rectangular	1.73	1	1	0.58	0.33	0.33	∞
Boundary effect	1.0	Rectangular	1.73	1	1	0.58	0.33	0.33	∞
Response time	0.8	Rectangular	1.73	1	1	0.46	0.21	0.21	∞
RF Ambient conditions	3.0	Rectangular	1.73	1	1	1.73	3.00	3.00	∞
Readout Electronics	0.3	Normal	1.00	1	1	0.30	0.09	0.09	∞
Integration time	2.6	Rectangular	1.73	1	1	1.50	2.25	2.25	∞
Probe positioner	0.4	Rectangular	1.73	1	1	0.23	0.05	0.05	∞
Probe positioning	2.9	Rectangular	1.73	1	1	1.67	2.80	2.80	∞
Maximum SAR evaluation	1.0	Rectangular	1.73	1	1	0.58	0.33	0.33	∞
Sub Total								65.69	
2. Test Sample Related									
Device Positioning	1.8	Normal	1.00	1	1	1.81	3.28	3.28	9
Device Holder	3.6	Normal	1.00	1	1	3.60	12.96	12.96	∞
Power Drift	5.0	Rectangular	1.73	1	1	2.89	8.33	8.33	∞
Sub Total								24.57	
3. Phantom and Setup									
Phantom Uncertainty	4.0	Rectangular	1.73	1	1	2.31	5.33	5.33	∞
Liquid conductivity (target)	5.0	Rectangular	1.73	0.5	0.25	2.89	8.33	2.08	∞
Liquid conductivity (measurement error)	2.5	Normal	1.00	0.5	0.25	2.50	6.25	1.56	∞
Liquid permittivity (target)	5.0	Rectangular	1.73	0.5	0.25	2.89	8.33	2.08	∞
Liquid permittivity (measurement error)	2.5	Normal	1.00	0.5	0.25	2.50	6.25	1.56	∞
Sub Total								12.63	
Combined standard SAR uncertainty [%]						10.14		102.88	-
Expanded uncertainty [k=2, approximately confidence level 95 %]						± 20.28 %			

Table 6.1 Breakdown of Errors

7. ANSI/ IEEE C95.1 - 2005 RF EXPOSURE LIMITS

HUMAN EXPOSURE	UNCONTROLLED ENVIRONMENT General Population (W/kg) or (mW/g)	CONTROLLED ENVIRONMENT Occupational (W/kg) or (mW/g)
SPATIAL PEAK SAR * (Brain)	1.60	8.00
SPATIAL AVERAGE SAR ** (Whole Body)	0.08	0.40
SPATIAL PEAK SAR *** (Hands / Feet / Ankle / Wrist)	4.00	20.00

Table 7.1 Safety Limits for Partial Body Exposure

NOTES:

* The Spatial Peak value of the SAR averaged over any 1 g of tissue (defined as a tissue volume in the shape of a cube) and over the appropriate averaging time.

** The Spatial Average value of the SAR averaged over the whole-body.

*** The Spatial Peak value of the SAR averaged over any 10 g of tissue (defined as a tissue volume in the shape of a cube) and over the appropriate averaging time.

Uncontrolled Environments are defined as locations where there is the exposure of individuals who have no knowledge or control of their exposure.

Controlled Environments are defined as locations where there is exposure that may be incurred by persons who are aware of the potential for exposure, (i.e.as a result of employment or occupation).

8. SYSTEM VERIFICATION

8.1 Tissue Verification

Freq. [MHz]	Date	Liquid	Liquid Temp.[°C]	Parameters	Target Value	Measured Value	Deviation [%]	Limit [%]
835	July 14, 2008	Head	21.2	ϵr	41.5	41.4	- 0.24	± 5
				σ	0.90	0.883	- 1.89	± 5
835	July 14, 2008	Body	21.2	ϵr	55.2	55.7	+ 0.91	± 5
				σ	0.97	0.99	+ 2.06	± 5
2 450	July 16, 2008	Head	21.2	ϵr	39.2	38.71	- 1.25	± 5
				σ	1.80	1.81	+ 0.55	± 5
2 450	July 16, 2008	Body	21.2	ϵr	52.7	50.94	- 3.33	± 5
				σ	1.95	2.03	+ 4.10	± 5

8.2 System Validation

Prior to assessment, the system is verified to the $\pm 10\%$ of the specifications at 835 MHz/ 2 450 MHz by using the system validation kit. (Graphic Plots Attached)

* Input Power: 1 W

Freq. [MHz]	Date	Liquid	Liquid Temp. [°C]	SAR Average	Target Value (SPEAG) (mW/g)	Measured Value (mW/g)	Deviation [%]	Limit [%]
835	July 14, 2008	Head	21.2	1 g	9.17	9.49	+ 3.49	± 10
2 450	July 16, 2008	Head	21.2	1 g	52.8	54.2	+ 2.65	± 10

9. TEST CONFIGURATIONS

SAR Testing with IEEE 802.11 a/b/g Transmitters

Normal Network operating configurations are not suitable for measuring the SAR of 802.11 a/b/g transmitters. Unpredictable fluctuations in network traffic and antenna diversity conditions can introduce undesirable variations in SAR results. The SAR for these devices should be measured using chipset based test mode software to ensure the results are consistent and reliable.

9.1 General Device Setup

Chipset based test mode software is hardware dependent and generally varies among manufacturers. The device operating parameters established in test mode for SAR measurements must be identical to those programmed in production units, including output power levels, amplifier gain settings and other RF performance tuning parameters. The test frequencies should correspond to actual channel frequencies defined for domestic use. SAR for devices with switched diversity should be measured with only one antenna transmitting at a time during each SAR measurement, according to a fixed modulation and data rate. The same data pattern should be used for all measurements.

9.2 Frequency Channel Configurations

80.11 a/b/g and 4.9 GHz operating modes are tested independently according to the service requirements in each frequency band. 80.211 b/g modes are tested on channels 1, 6 and 11. 802.11a is tested for UNII operations on channels 36 and 48 in the 5.15-5.25 GHz band; channels 52 and 64 in the 5.25-5.35 GHz band; Channels 104, 116, 124 and 136 in the 5.470-5.725 GHz band; and channels 149 and 161 in the 5.8 GHz band. When 5.8 GHz § 15.247 is also available, channels 149, 157 and 165 should be tested instead of the UNII channels. 4.9 GHz is tested on channels 1, 10 and 5 or 6, whichever has the higher output power, for 5 MHz channels; channels 11, 15 and 19 for 10 MHz channels; and channels 21 and 25 for 20 MHz channels.

These are referred to as the "default test channels". 802.11g mode was evaluated only if the output power was 0.25 dB higher than the 802.11b mode.

Mode	GHz	Channel	Turbo Channel	"Default Test Channels"			
				§15.247		UNII	
				802.11b	802.11g		
802.11 b/g	2.412	1		√	▽		
	2.437	6	6	√	▽		
	2.462	11		√	▽		
802.11a	5.18	36				√	
	5.20	40	42 (5.21 GHz)			*	
	5.22	44				*	
	5.24	48				√	
	5.26	52	50 (5.25 GHz)			√	
	5.28	56	58 (5.29 GHz)			*	
	5.30	60				*	
	5.32	64				√	
	5.500	100	Unknown				*
	5.520	104					√
	5.540	108					*
	5.560	112					*
	5.580	116					√
	5.600	120					*
	5.620	124					√
	5.640	128					*
	5.660	132					*
	5.680	136					√
	5.700	140				*	
	UNII or §15.247	5.745	149		√		√
5.765		153	152 (5.76 GHz)		*	*	
5.785		157		√		*	
5.805		161	160 (5.80 GHz)		*	√	
§15.247	5.825	165		√			

802.11 Test Channels per FCC Requirements

10. 3G MEASUREMENT PROCEDURES

10.1 Procedures Used To Establish Test Signal

The handset was placed into a simulated call using a base station simulator in a shielded chamber. Such test signals offer a consistent means for testing SAR and are recommended for evaluating SAR. SAR measurements were taken with a fully charged battery. In order to verify that the device was tested and maintained at full power, this was configured with the base station simulator. The SAR measurement software calculates a reference point at the start and end of the test to check for power drifts. If conducted power deviations of more than 5% occurred, the tests were repeated.

10.2 SAR Measurement Conditions for CDMA2000 1x

These procedures were followed according to FCC "SAR Measurement Procedures for 3G Devices", May 2006.

10.2.1 Output Power Verification

See 3GPP2 C.S0011/TIA-98-E as recommended by "SAR Measurement Procedures for 3G Devices", May 2006. Maximum output power is verified on the High, Middle and Low channels according to procedures defined in section 4.4.5.2 of 3GPP2 C.S0011/TIA-98-E. SO55 tests were measured with power control bits in "All Up" condition.

1. If the mobile station supports Reverse TCH RC 1 and Forward TCH RC 1, set up a call using Fundamental Channel Test Mode 1 (RC=1/1) with 9 600 bps data rate only.
2. Under RC1, C.S0011 Table 4.4.5.2-1 (Table 9.1) parameters were applied.
3. If the MS supports the RC 3 Reverse FCH, RC3 Reverse SCH0 and demodulation of RC 3, 4, or 5, set up a call using Supplemental Channel Test Mode 3 (RC 3/3) with 9 600 bps Fundamental Channel and 9 600 bps SCH0 data rate Channel and 9 600 bps SCH0 data rate.
4. Under RC3, C.S0011 Table 4.4.5.2-2 (Table 9.2) was applied.
5. FCHs were configured at full rate for maximum SAR with "All Up" power control bits.

Parameters for Max. Power for RC1

Parameter	Units	Value
\bar{I}_{or}	dBm/1.23 MHz	-104
$\frac{\text{Pilot } E_c}{\bar{I}_{or}}$	dB	-7
$\frac{\text{Traffic } E_c}{\bar{I}_{or}}$	dB	-7.4

Table. 10.1

Parameters for Max. Power for RC3

Parameter	Units	Value
\bar{I}_{or}	dBm/1.23 MHz	-86
$\frac{\text{Pilot } E_c}{\bar{I}_{or}}$	dB	-7
$\frac{\text{Traffic } E_c}{\bar{I}_{or}}$	dB	-7.4

Table. 10.2

10.2.2 Head SAR Measurement

SAR for head exposure configurations is measured in RC3 with the DUT configured to transmit at full rate using Loopback Service Option SO55. SAR for RC1 is not required when the maximum average output of each channel is less than ¼ dB higher than that measured in RC3. Otherwise, SAR is measured on the maximum output channel in RC1 using the exposure configuration that results in the highest SAR for that channel in RC3.

10.2.3 Body SAR Measurement

SAR for body exposure configurations is measured in RC3 with the DUT configured to transmit at full rate on FCH with all other code channels disabled using TDSO / SO32. SAR for multiple code channels (FCH + SCHn) is not required when the maximum average output of each RF channel is less than ¼ dB higher than that measured with FCH only. Otherwise, SAR is measured on the maximum output channel (FCH + SCHn) with FCH at full rate and SCH0 enabled at 9 600 bps using the exposure configuration that results in the highest SAR for that channel with FCH only. When multiple code channels are enabled, the DUT output may shift by more than 0.5 dB and lead to higher SAR drifts and SCH dropouts.

Body SAR in RC1 is not required when the maximum average output of each channel is less than ¼ dB higher than that measured in RC3. Otherwise, SAR is measured on the maximum output channel in RC1; with Loopback Service Option SO55, at full rate, using the body exposure configuration that results in the highest SAR for that channel in RC3.

10.2.4 Handsets with EV-DO

For handsets with Ev-Do capabilities, when the maximum average output of each channel in Rev. 0 is less than ¼ dB higher than that measured in RC3 (1x RTT), body SAR for Ev-Do is not required. Otherwise, SAR for Rev. 0 is measured on the maximum output channel at 153.6 kbps using the body exposure configuration that results in the highest SAR for that channel in RC3. SAR for Rev. A is not required when the maximum average output of each channel is less than that measured in Rev. 0 or less than ¼ dB higher than that measured in RC3. Otherwise, SAR is measured on the maximum output channel for Rev. A using a Reverse Data Channel payload size of 4 096 bits and a Termination Target of 16 slots defined for Subtype 2 Physical Layer configurations. A Forward Traffic Channel data rate corresponding to the 2-slot version of 307.2 kbps with the ACK Channel transmitting in all slots should be configured in the downlink for both Rev. 0 and Rev. A.

Average Output Power Measurement for FCC ID: PH7MV420A

Band	Channel	SO2	SO2	SO55	SO55	TDSO	1xEvDO	1xEvDO	1xEvDO	1xEvDO
		RC1/1	RC3/3	RC1/1	RC3/3	SO32	Rev.0	Rev.0	Rev.A	Rev.A
							(FTAP)	(RTAP)	(FETAP)	(RETAP)
CDMA	1013	23.36	23.32	23.35	23.32	23.30	23.85	23.83	23.84	23.78
	384	23.40	23.32	23.35	23.29	23.30	23.95	23.96	23.91	23.86
	777	23.30	23.21	23.32	23.21	23.20	23.75	23.75	23.85	23.78

11. SAR Evaluation Considerations for Handsets with Multiple Transmitters and Antennas

11.1 SAR Evaluation Considerations

These procedures were followed according to FCC "SAR Evaluation Considerations for Handsets with Multiple Transmitters and Antennas", February 2008. The procedures are applicable to phones with built-in unlicensed transmitters, such as 802.11 a/b/g and Bluetooth devices.

	2.45	5.15 - 5.35	5.47 - 5.85	GHz
P_{Ref}	12	6	5	mW
Device output power should be rounded to the nearest mW to compare with values specified in this				

Table. 11.1 Output Power Thresholds for Unlicensed Transmitters

	Individual Transmitter	Simultaneous Transmission
Licensed Transmitters	<u>Routine evaluation required</u>	SAR not required: <u>Unlicensed only</u>
Unlicensed Transmitters	<u>When there is no simultaneous transmission-</u> * output < 60/f: SAR not required * output < 60/f: stand-alone SAR required <u>When there is simultaneous transmission-</u> <u>Stand-alone SAR not required when</u> * output ≤ 2 · P _{Ref} and antenna is > 5.0 cm from other antennas * output ≤ P _{Ref} and antenna is > 2.5 cm from other antennas <u>Otherwise stand-alone SAR is required</u> <u>When stand-alone SAR is required</u> * test SAR on highest output channel For each wireless mode and exposure Condition * if SAR for highest output channel is > 50 % of SAR limit, evaluate all channels According to normal procedures	* when stand-alone 1-g SAR is not Required and antenna is > 5 cm From other antennas <u>Licensed & Unlicensed</u> * when the sum of the l-g SAR is < 1.6 W/kg for all simultaneous transmitting antenna pair is < 0.3 SAR Required: <u>Licensed & Unlicensed</u> Antenna pairs with SAR to antenna separation ratio test is only required for the configuration that highest SAR in stand-alone configuration for each wireless Note : simultaneous transmission Exposure head and bodycon be different for different style phone therefore, different test requirements may apply

Table. 11.2 SAR Evaluation Requirements for Cellphones with Multiple Transmitters

FCC ID: PH7MV420A

WLAN Max. RF output power: 802.11b; 24.50 dBm, 802.11g; 20.87 dBm
 Antenna separation distance on the PCB: 7.5 cm
 Distance between External Transmitting Antennas: 5.1 cm

Because the conducted output power level of the WLAN transmitter is more than 2*P_{ref}, although the WLAN antenna is more than 5.0 cm from the CDMA antenna, stand-alone WLAN SAR are required for the EUT. The device is capable of simultaneous transmission between CDMA and WLAN, but the Cell-to-WLAN ratio is (0.731 + 0.444)/ 5.1 = 0.230 < 0.3. Therefore a simultaneous SAR evaluation is not required.

12. SAR TEST DATA SUMMARY

12.1 Measurement Results (CDMA Body SAR)

Frequency		Modulation	Conducted Power (dBm)		Battery	Separation Distance	Ant. Position	SAR(mW/g)
MHz	Channel.		Begin	End				
824.70	1013 (Low)	EVDO	23.83	23.81	With Charger	2.0 cm	90 degree upright	0.727
836.52	384 (Mid)	EVDO	23.96	24.06	With Charger	2.0 cm	90 degree upright	0.731
848.31	777 (High)	EVDO	23.75	23.86	With Charger	2.0 cm	90 degree upright	0.679
824.70	1013 (Low)	CDMA835	23.30	23.16	With Charger	2.0 cm	90 degree upright	0.702
836.52	384 (Mid)	CDMA835	23.30	23.33	With Charger	2.0 cm	90 degree upright	0.677
848.31	777 (High)	CDMA835	23.20	23.17	With Charger	2.0 cm	90 degree upright	0.664
836.52	384 (Mid)	EVDO	23.96	23.95	Standard	2.0 cm	90 degree upright	0.581
ANSI/ IEEE C95.1 2005 – Safety Limit Spatial Peak Uncontrolled Exposure/ General Population						Body 1.6 W/kg (mW/g) Averaged over 1 gram		

NOTES:

- The test data reported are the worst-case SAR value with the antenna-head position set in a typical configuration. Test procedures used are according to FCC/OET Bulletin 65, Supplement C [July 2001].
- All modes of operation were investigated and the worst-case are reported.
- Measured Depth of Simulating Tissue is 15.0 cm ± 0.2 cm.
- Tissue parameters and temperatures are listed on the SAR plot.
- Battery Type Standard with Charger Extended Slim
Batteries are fully charged for all readings.
- Test Signal Call Mode Manual Test code Base Station Simulator
- EVDO Body SAR was tested under Rev.0 RTAP mode.

13. CONCLUSION

The SAR measurement indicates that the EUT complies with the RF radiation exposure limits of the ANSI/IEEE C95.1 2005.

These measurements are taken to simulate the RF effects exposure under worst-case conditions. Precise laboratory measures were taken to assure repeatability of the tests.

14. REFERENCES

- [1] Federal Communications Commission, OET Bulletin 65 (Edition 97-01), Supplement C (Edition 01-01), Evaluating Compliance with FCC Guidelines for Human Exposure to Radio frequency Electromagnetic Fields, July 2001.
- [2] IEEE Standards Coordinating Committee 34 – IEEE Std. 1528-2003, IEEE Recommended Practice for Determining the Peak Spatial-Average Specific Absorption Rate (SAR) in the Human Body from Wireless Communications Devices.
- [3] Federal Communications Commission, ET Docket 93-62, Guidelines for Evaluating the Environmental Effects of Radio frequency Radiation, Aug. 1996.
- [4] ANSI/IEEE C95.1 - 1991, American National Standard safety levels with respect to human exposure to radio frequency electromagnetic fields, 300 kHz to 100 GHz, New York: IEEE, Aug. 1992
- [5] ANSI/IEEE C95.3 - 1991, IEEE Recommended Practice for the Measurement of Potentially Hazardous Electromagnetic Fields - RF and Microwave, New York: IEEE, 1992.
- [6] NCRP, National Council on Radiation Protection and Measurements, Biological Effects and Exposure Criteria for Radio Frequency Electromagnetic Fields, NCRP Report No. 86, 1986. Reprinted Feb. 1995.
- [7] T. Schmid, O. Egger, N. Kuster, Automated E-field scanning system for dosimetric assessments, IEEE Transaction on Microwave Theory and Techniques, vol. 44, Jan. 1996, pp. 105-113.
- [8] K. Pokovic, T. Schmid, N. Kuster, Robust setup for precise calibration of E-field probes in tissue simulating liquids at mobile communications frequencies, ICECOM97, Oct. 1997, pp. 120-124.
- [9] K. Pokovic, T. Schmid, and N. Kuster, E-field Probe with improved isotropy in brain simulating liquids, Proceedings of the ELMAR, Zadar, Croatia, June 23-25, 1996, pp. 172-175.
- [10] Schmid & Partner Engineering AG, Application Note: Data Storage and Evaluation, June 1998, p2.
- [11] V. Hombach, K. Meier, M. Burkhardt, E. Kuhn, N. Kuster, The Dependence of EM Energy Absorption upon Human Head Modeling at 900 MHz, IEEE Transaction on Microwave Theory and Techniques, vol. 44 no. 10, Oct. 1996, pp. 1865-1873.
- [12] N. Kuster and Q. Balzano, Energy absorption mechanism by biological bodies in the near field of dipole antennas above 300 MHz, IEEE Transaction on Vehicular Technology, vol. 41, no. 1, Feb. 1992, pp. 17-23.
- [13] G. Hartsgrove, A. Kraszewski, A. Surowiec, Simulated Biological Materials for Electromagnetic Radiation Absorption Studies, University of Ottawa, Bioelectromagnetics, Canada: 1987, pp. 29-36.
- [14] Q. Balzano, O. Garay, T. Manning Jr., Electromagnetic Energy Exposure of Simulated Users of Portable Cellular Telephones, IEEE Transactions on Vehicular Technology, vol. 44, no.3, Aug. 1995.
- [15] W. Gander, Computer mathematick, Birkhaeuser, Basel, 1992.
- [16] W.H. Press, S.A. Teukolsky, W.T. Vetterling, and B.P. Flannery, Numerical Recipes in C, The Art of Scientific Computing, Second edition, Cambridge University Press, 1992.
- [17] Federal Communications Commission, OET Bulletin 65, Evaluating Compliance with FCC Guidelines for Human Exposure to Radiofrequency Electromagnetic Fields. Supplement C, Dec. 1997.
- [18] N. Kuster, R. Kastle, T. Schmid, Dosimetric evaluation of mobile communications equipment with known precision, IEEE Transaction on Communications, vol. E80-B, no. 5, May 1997, pp. 645-652.
- [19] CENELEC CLC/SC111B, European Prestandard (prENV 50166-2), Human Exposure to Electromagnetic Fields High-frequency: 10 kHz-300 GHz, Jan. 1995.
- [20] Prof. Dr. Niels Kuster, ETH, Eidgenössische Technische Hochschule Zürich, Dosimetric Evaluation of the Cellular Phone.
- [21] FCC SAR Considerations for Cell Phones with Multiple Transmitters #648474, February 2008.

Attachment 1. – SAR Test Plots

Test Laboratory: HCT CO., LTD
EUT Type: Cellular CDMA Wireless Gateway with WLAN
Liquid Temperature: 21.2 °C
Ambient Temperature: 21.4 °C
Test Date: July 14, 2008
Option: EVDO

DUT: MV420A; Type: CDMA WLL Phone; Serial:#1

Communication System: CDMA 835MHz FCC; Frequency: 824.7 MHz; Duty Cycle: 1:1
Medium parameters used: $f = 825$ MHz; $\sigma = 0.98$ mho/m; $\epsilon_r = 55.9$; $\rho = 1000$ kg/m³
Phantom section: Flat Section ; Measurement SW: DASY4, V4.6 Build 23; Postprocessing SW: SEMCAD, V1.8 Build 176

DASY4 Configuration:

- Probe: ET3DV6 - SN1798; ConvF(6.29, 6.29, 6.29); Calibrated: 2008-03-20
- Sensor-Surface: 4mm (Mechanical Surface Detection)
- Electronics: DAE4 Sn447; Calibrated: 2007-09-13
- Phantom: 835/900 Phantom ; Type: SAM

Body CDMA 1013/Area Scan (101x111x1): Measurement grid: dx=15mm, dy=15mm

Maximum value of SAR (interpolated) = 0.779 mW/g

Body CDMA 1013/Zoom Scan (5x5x7)/Cube 0: Measurement grid: dx=8mm, dy=8mm, dz=5mm

Reference Value = 28.3 V/m; Power Drift = -0.021 dB

Peak SAR (extrapolated) = 0.953 W/kg

SAR(1 g) = 0.727 mW/g; SAR(10 g) = 0.520 mW/g

Maximum value of SAR (measured) = 0.768 mW/g

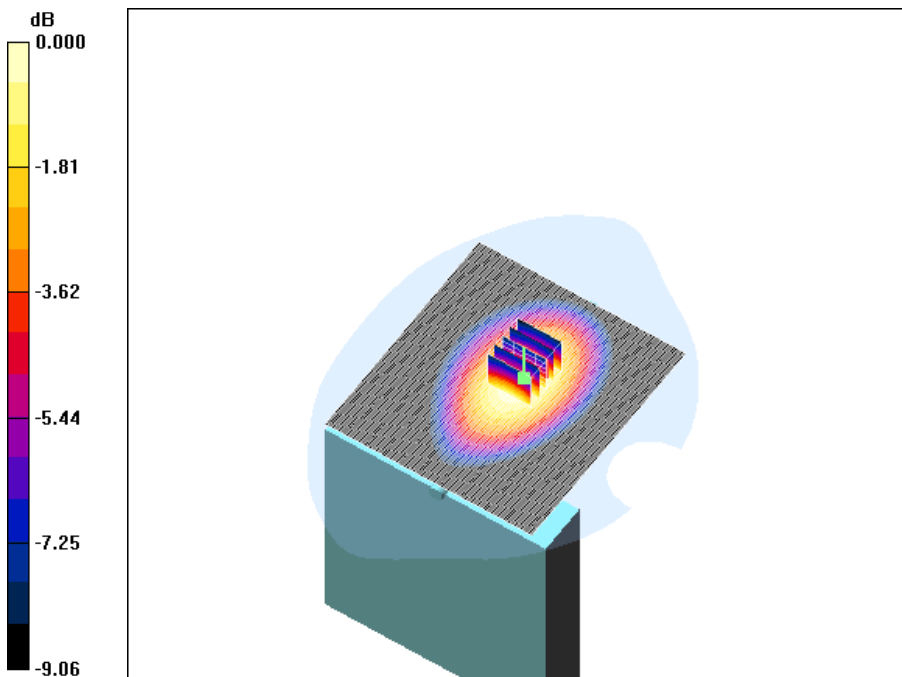

0 dB = 0.768mW/g

Test Laboratory: HCT CO., LTD
EUT Type: Cellular CDMA Wireless Gateway with WLAN
Liquid Temperature: 21.2 °C
Ambient Temperature: 21.4 °C
Test Date: July 14, 2008
Option: EVDO

DUT: MV420A; Type: CDMA WLL Phone; Serial:#1

Communication System: CDMA 835MHz FCC; Frequency: 836.52 MHz; Duty Cycle: 1:1
Medium parameters used (interpolated): $f = 836.52$ MHz; $\sigma = 0.992$ mho/m; $\epsilon_r = 55.7$; $\rho = 1000$ kg/m³
Phantom section: Flat Section ; Measurement SW: DASY4, V4.6 Build 23; Postprocessing SW: SEMCAD, V1.8 Build 176

DASY4 Configuration:

- Probe: ET3DV6 - SN1798; ConvF(6.29, 6.29, 6.29); Calibrated: 2008-03-20
- Sensor-Surface: 4mm (Mechanical Surface Detection)
- Electronics: DAE4 Sn447; Calibrated: 2007-09-13
- Phantom: 835/900 Phantom ; Type: SAM

Body CDMA 384/Area Scan (101x111x1): Measurement grid: dx=15mm, dy=15mm

[Info: Interpolated medium parameters used for SAR evaluation.](#)

Maximum value of SAR (interpolated) = 0.768 mW/g

Body CDMA 384/Zoom Scan (5x5x7)/Cube 0: Measurement grid: dx=8mm, dy=8mm, dz=5mm

Reference Value = 27.6 V/m; Power Drift = 0.097 dB

Peak SAR (extrapolated) = 0.956 W/kg

SAR(1 g) = 0.731 mW/g; SAR(10 g) = 0.522 mW/g

[Info: Interpolated medium parameters used for SAR evaluation.](#)

Maximum value of SAR (measured) = 0.775 mW/g

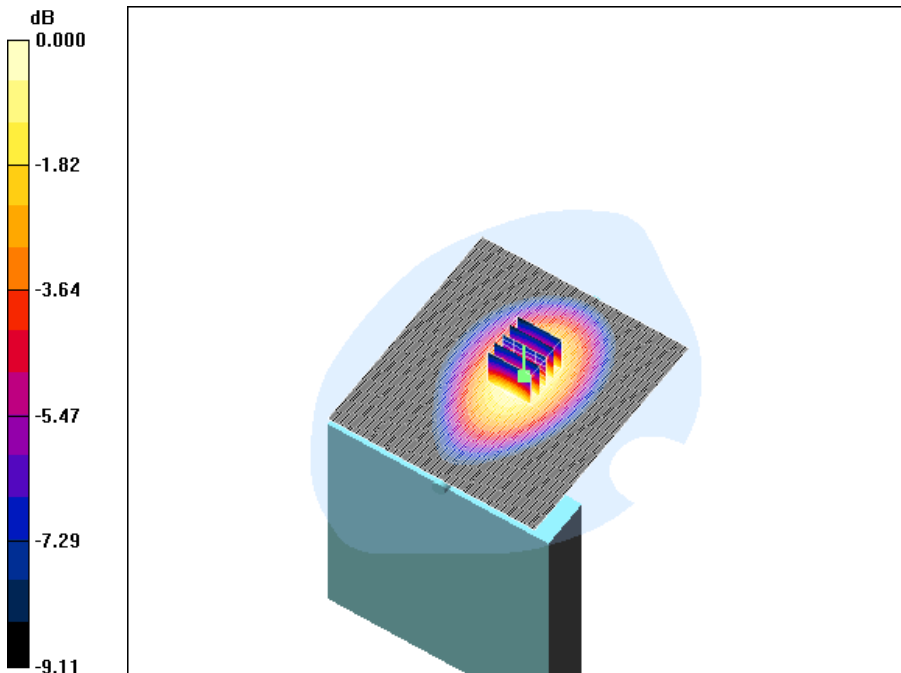

0 dB = 0.775mW/g

Test Laboratory: HCT CO., LTD
 EUT Type: Cellular CDMA Wireless Gateway with WLAN
 Liquid Temperature: 21.2 °C
 Ambient Temperature: 21.4 °C
 Test Date: July 14, 2008
 Option: EVDO

DUT: MV420A; Type: CDMA WLL Phone; Serial:#1

Communication System: CDMA 835MHz FCC; Frequency: 848.31 MHz; Duty Cycle: 1:1
 Medium parameters used (interpolated): $f = 848.31 \text{ MHz}$; $\sigma = 1 \text{ mho/m}$; $\epsilon_r = 55.6$; $\rho = 1000 \text{ kg/m}^3$
 Phantom section: Flat Section ; Measurement SW: DASY4, V4.6 Build 23; Postprocessing SW: SEMCAD, V1.8 Build 176

DASY4 Configuration:

- Probe: ET3DV6 - SN1798; ConvF(6.29, 6.29, 6.29); Calibrated: 2008-03-20
- Sensor-Surface: 4mm (Mechanical Surface Detection)
- Electronics: DAE4 Sn447; Calibrated: 2007-09-13
- Phantom: 835/900 Phantom ; Type: SAM

Body CDMA 777/Area Scan (101x111x1): Measurement grid: dx=15mm, dy=15mm

[Info: Interpolated medium parameters used for SAR evaluation.](#)

Maximum value of SAR (interpolated) = 0.721 mW/g

Body CDMA 777/Zoom Scan (5x5x7)/Cube 0: Measurement grid: dx=8mm, dy=8mm, dz=5mm

Reference Value = 26.9 V/m; Power Drift = 0.105 dB

Peak SAR (extrapolated) = 0.884 W/kg

SAR(1 g) = 0.679 mW/g; SAR(10 g) = 0.484 mW/g

[Info: Interpolated medium parameters used for SAR evaluation.](#)

Maximum value of SAR (measured) = 0.719 mW/g

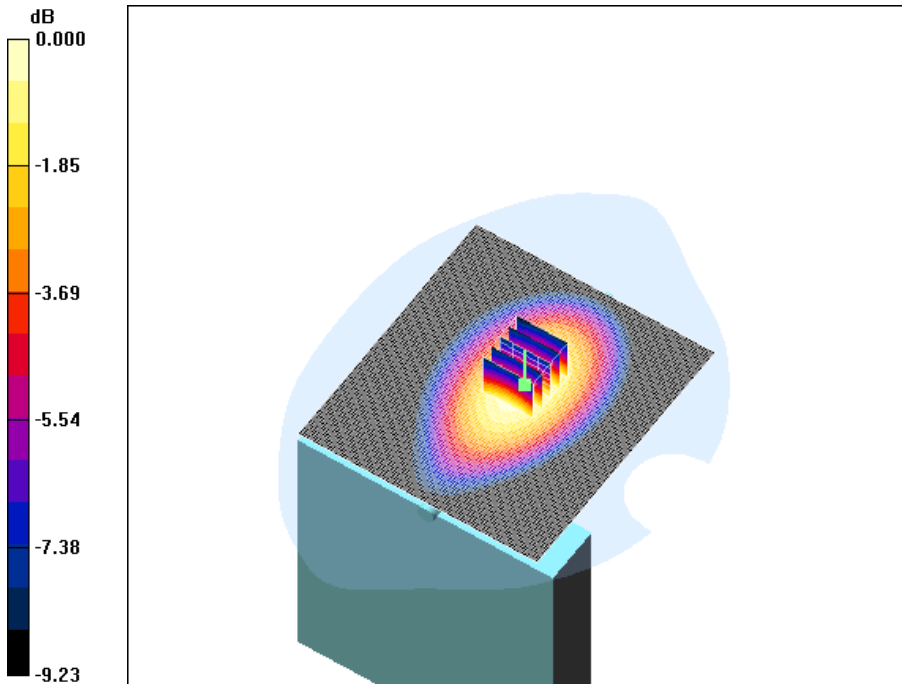

0 dB = 0.719mW/g

Test Laboratory: HCT CO., LTD
EUT Type: Cellular CDMA Wireless Gateway with WLAN
Liquid Temperature: 21.2 °C
Ambient Temperature: 21.4 °C
Test Date: July 14, 2008

DUT: MV420A; Type: CDMA WLL Phone; Serial:#1

Communication System: CDMA 835MHz FCC; Frequency: 824.7 MHz;Duty Cycle: 1:1
Medium parameters used: $f = 825$ MHz; $\sigma = 0.98$ mho/m; $\epsilon_r = 55.9$; $\rho = 1000$ kg/m³
Phantom section: Flat Section ; Measurement SW: DASY4, V4.6 Build 23; Postprocessing SW: SEMCAD, V1.8 Build 176

DASY4 Configuration:

- Probe: ET3DV6 - SN1798; ConvF(6.29, 6.29, 6.29); Calibrated: 2008-03-20
- Sensor-Surface: 4mm (Mechanical Surface Detection)
- Electronics: DAE4 Sn447; Calibrated: 2007-09-13
- Phantom: 835/900 Phantom ; Type: SAM

Body CDMA 1013/Area Scan (101x111x1): Measurement grid: dx=15mm, dy=15mm
Maximum value of SAR (interpolated) = 0.758 mW/g

Body CDMA 1013/Zoom Scan (5x5x7)/Cube 0: Measurement grid: dx=8mm, dy=8mm, dz=5mm
Reference Value = 27.8 V/m; Power Drift = -0.144 dB
Peak SAR (extrapolated) = 0.909 W/kg
SAR(1 g) = 0.702 mW/g; SAR(10 g) = 0.502 mW/g
Maximum value of SAR (measured) = 0.741 mW/g

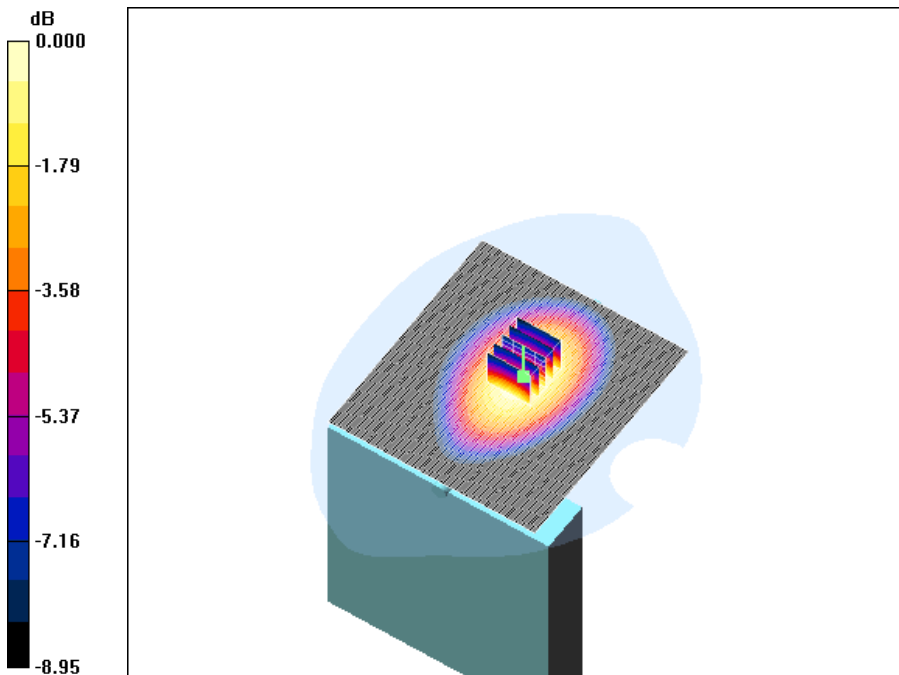

0 dB = 0.741mW/g

Test Laboratory: HCT CO., LTD
EUT Type: Cellular CDMA Wireless Gateway with WLAN
Liquid Temperature: 21.2 °C
Ambient Temperature: 21.4 °C
Test Date: July 14, 2008

DUT: MV420A; Type: CDMA WLL Phone; Serial:#1

Communication System: CDMA 835MHz FCC; Frequency: 836.52 MHz; Duty Cycle: 1:1
Medium parameters used (interpolated): $f = 836.52$ MHz; $\sigma = 0.992$ mho/m; $\epsilon_r = 55.7$; $\rho = 1000$ kg/m³
Phantom section: Flat Section ; Measurement SW: DASY4, V4.6 Build 23; Postprocessing SW: SEMCAD, V1.8 Build 176

DASY4 Configuration:

- Probe: ET3DV6 - SN1798; ConvF(6.29, 6.29, 6.29); Calibrated: 2008-03-20
- Sensor-Surface: 4mm (Mechanical Surface Detection)
- Electronics: DAE4 Sn447; Calibrated: 2007-09-13
- Phantom: 835/900 Phantom ; Type: SAM

Body CDMA 384/Area Scan (101x111x1): Measurement grid: dx=15mm, dy=15mm

[Info: Interpolated medium parameters used for SAR evaluation.](#)

Maximum value of SAR (interpolated) = 0.730 mW/g

Body CDMA 384/Zoom Scan (5x5x7)/Cube 0: Measurement grid: dx=8mm, dy=8mm, dz=5mm

Reference Value = 27.0 V/m; Power Drift = 0.031 dB

Peak SAR (extrapolated) = 0.867 W/kg

SAR(1 g) = 0.677 mW/g; SAR(10 g) = 0.484 mW/g

[Info: Interpolated medium parameters used for SAR evaluation.](#)

Maximum value of SAR (measured) = 0.719 mW/g

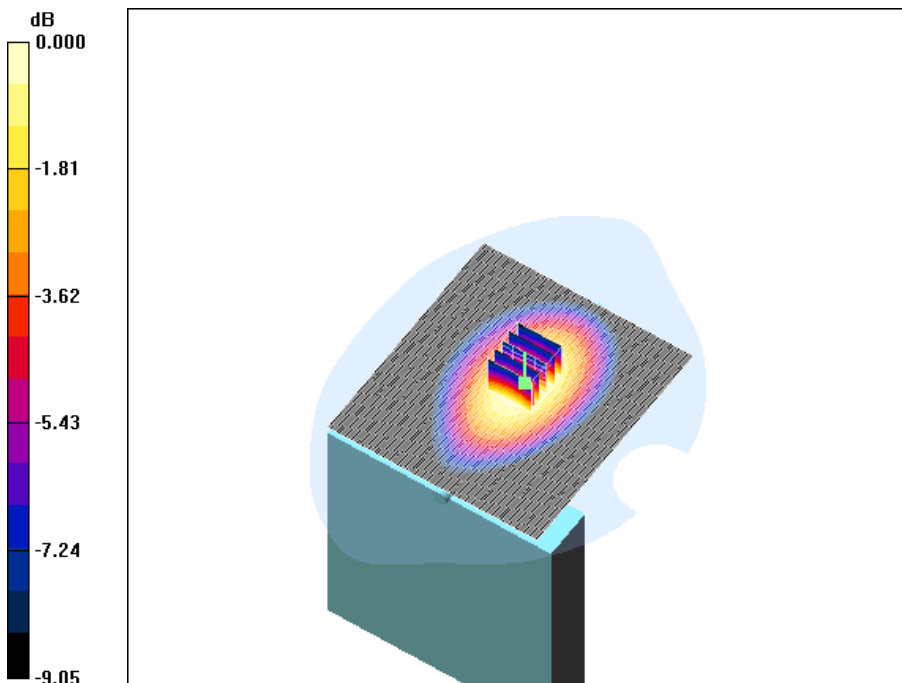

0 dB = 0.719mW/g

Test Laboratory: HCT CO., LTD
EUT Type: Cellular CDMA Wireless Gateway with WLAN
Liquid Temperature: 21.2 °C
Ambient Temperature: 21.4 °C
Test Date: July 14, 2008

DUT: MV420A; Type: CDMA WLL Phone; Serial:#1

Communication System: CDMA 835MHz FCC; Frequency: 848.31 MHz; Duty Cycle: 1:1
Medium parameters used (interpolated): $f = 848.31$ MHz; $\sigma = 1$ mho/m; $\epsilon_r = 55.6$; $\rho = 1000$ kg/m³
Phantom section: Flat Section ; Measurement SW: DASY4, V4.6 Build 23; Postprocessing SW: SEMCAD, V1.8 Build 176

DASY4 Configuration:

- Probe: ET3DV6 - SN1798; ConvF(6.29, 6.29, 6.29); Calibrated: 2008-03-20
- Sensor-Surface: 4mm (Mechanical Surface Detection)
- Electronics: DAE4 Sn447; Calibrated: 2007-09-13
- Phantom: 835/900 Phantom ; Type: SAM

Body CDMA 777/Area Scan (101x111x1): Measurement grid: dx=15mm, dy=15mm

[Info: Interpolated medium parameters used for SAR evaluation.](#)

Maximum value of SAR (interpolated) = 0.699 mW/g

Body CDMA 777/Zoom Scan (5x5x7)/Cube 0: Measurement grid: dx=8mm, dy=8mm, dz=5mm

Reference Value = 26.7 V/m; Power Drift = -0.033 dB

Peak SAR (extrapolated) = 0.869 W/kg

SAR(1 g) = 0.664 mW/g; SAR(10 g) = 0.471 mW/g

[Info: Interpolated medium parameters used for SAR evaluation.](#)

Maximum value of SAR (measured) = 0.711 mW/g

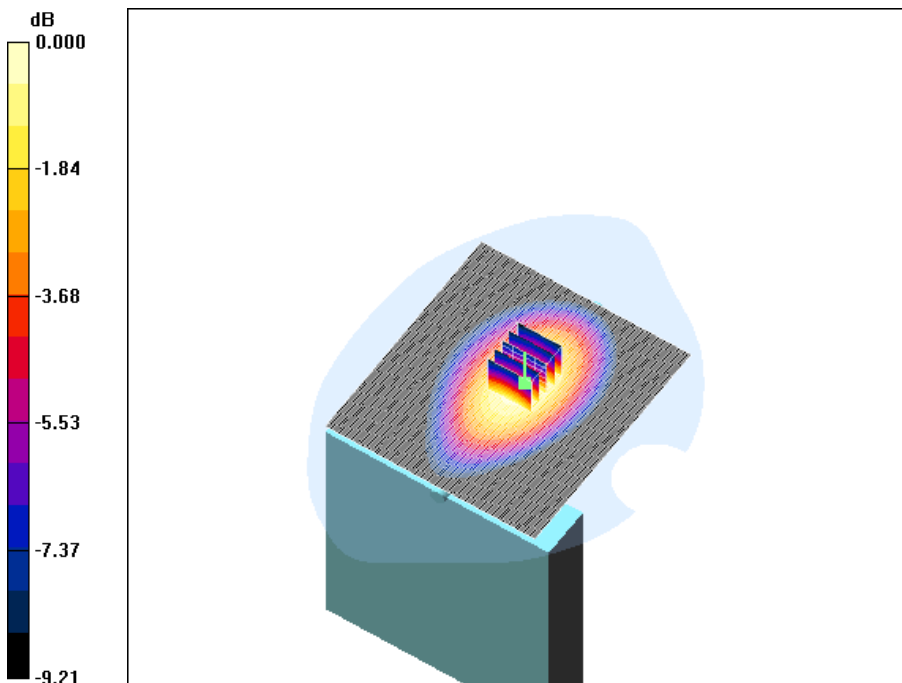

0 dB = 0.711mW/g

Test Laboratory: HCT CO., LTD
EUT Type: Cellular CDMA Wireless Gateway with WLAN
Liquid Temperature: 21.2 °C
Ambient Temperature: 21.4 °C
Test Date: July 14, 2008
Option: Standard Battery

DUT: MV420A; Type: CDMA WLL Phone; Serial:#1

Communication System: CDMA 835MHz FCC; Frequency: 836.52 MHz; Duty Cycle: 1:1
Medium parameters used (interpolated): $f = 836.52$ MHz; $\sigma = 0.992$ mho/m; $\epsilon_r = 55.7$; $\rho = 1000$ kg/m³
Phantom section: Flat Section ; Measurement SW: DASY4, V4.6 Build 23; Postprocessing SW: SEMCAD, V1.8 Build 176

DASY4 Configuration:

- Probe: ET3DV6 - SN1798; ConvF(6.29, 6.29, 6.29); Calibrated: 2008-03-20
- Sensor-Surface: 4mm (Mechanical Surface Detection)
- Electronics: DAE4 Sn447; Calibrated: 2007-09-13
- Phantom: 835/900 Phantom ; Type: SAM

Body CDMA 384/Area Scan (101x111x1): Measurement grid: dx=15mm, dy=15mm

[Info: Interpolated medium parameters used for SAR evaluation.](#)

Maximum value of SAR (interpolated) = 0.624 mW/g

Body CDMA 384/Zoom Scan (5x5x7)/Cube 0: Measurement grid: dx=8mm, dy=8mm, dz=5mm

Reference Value = 24.3 V/m; Power Drift = 0.010 dB

Peak SAR (extrapolated) = 0.756 W/kg

SAR(1 g) = 0.581 mW/g; SAR(10 g) = 0.413 mW/g

[Info: Interpolated medium parameters used for SAR evaluation.](#)

Maximum value of SAR (measured) = 0.621 mW/g

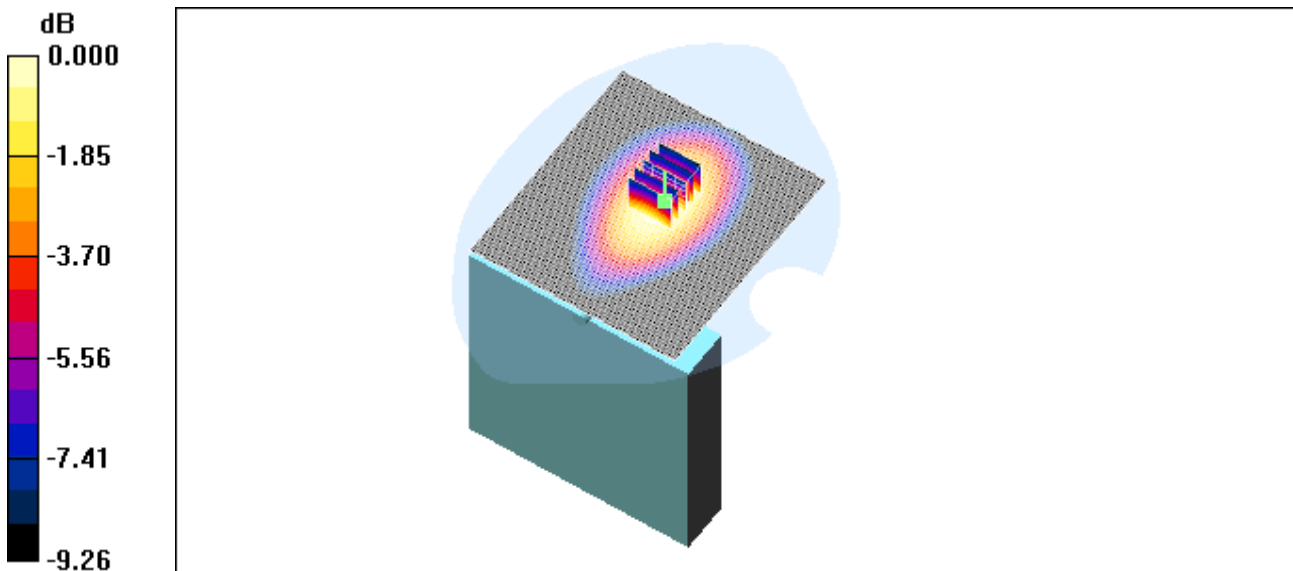

0 dB = 0.621mW/g

Test Laboratory: HCT CO., LTD
EUT Type: Cellular CDMA Wireless Gateway with WLAN
Liquid Temperature: 21.2 °C
Ambient Temperature: 21.4 °C
Test Date: July 16, 2008

DUT: MV420A; Type: CDMA WLL Phone; Serial:#1

Communication System: 2450MHz FCC; Frequency: 2412 MHz; Duty Cycle: 1:1
Medium parameters used (interpolated): $f = 2412$ MHz; $\sigma = 1.96$ mho/m; $\epsilon_r = 51.2$; $\rho = 1000$ kg/m³
Phantom section: Flat Section ; Measurement SW: DASY4, V4.6 Build 23; Postprocessing SW: SEMCAD, V1.8 Build 176

DASY4 Configuration:

- Probe: ET3DV6 - SN1798; ConvF(4.32, 4.32, 4.32); Calibrated: 2008-03-20
- Sensor-Surface: 4mm (Mechanical Surface Detection)
- Electronics: DAE4 Sn447; Calibrated: 2007-09-13
- Phantom: 1800/1900 Phantom; Type: SAM

WIFI 801.11b 1/Area Scan (101x111x1): Measurement grid: dx=15mm, dy=15mm[Info: Interpolated medium parameters used for SAR evaluation.](#)

Maximum value of SAR (interpolated) = 0.474 mW/g

WIFI 801.11b 1/Zoom Scan (5x5x7)/Cube 0: Measurement grid: dx=8mm, dy=8mm, dz=5mm

Reference Value = 6.50 V/m; Power Drift = -0.126 dB

Peak SAR (extrapolated) = 0.937 W/kg

SAR(1 g) = 0.444 mW/g; SAR(10 g) = 0.235 mW/g[Info: Interpolated medium parameters used for SAR evaluation.](#)

Maximum value of SAR (measured) = 0.476 mW/g

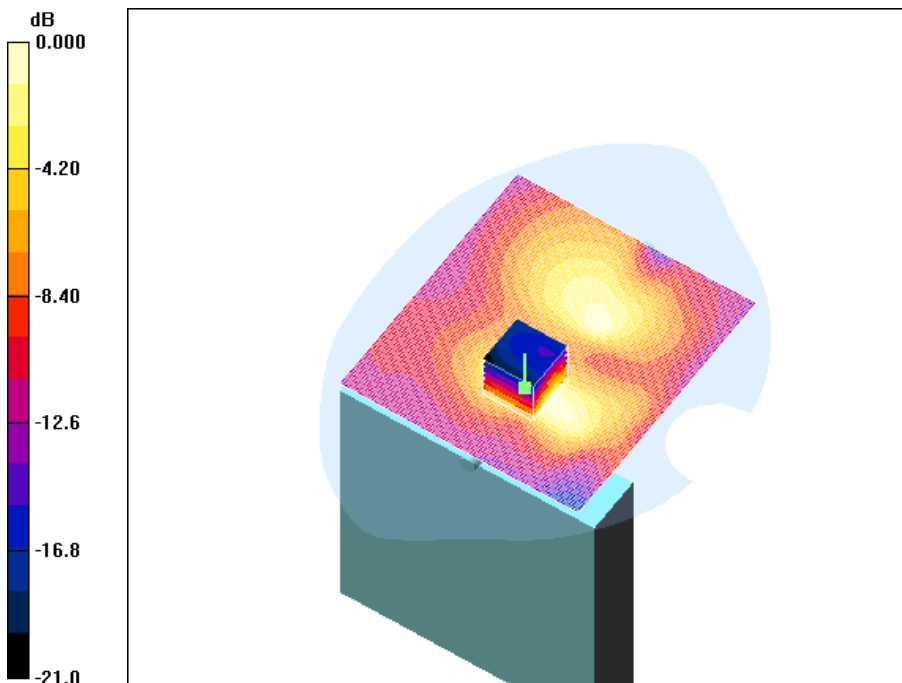

0 dB = 0.476mW/g

Test Laboratory: HCT CO., LTD
EUT Type: Cellular CDMA Wireless Gateway with WLAN
Liquid Temperature: 21.2 °C
Ambient Temperature: 21.4 °C
Test Date: July 16, 2008

DUT: MV420A; Type: CDMA WLL Phone; Serial:#1

Communication System: 2450MHz FCC; Frequency: 2437 MHz; Duty Cycle: 1:1
Medium parameters used (interpolated): $f = 2437$ MHz; $\sigma = 2.01$ mho/m; $\epsilon_r = 51$; $\rho = 1000$ kg/m³
Phantom section: Flat Section ; Measurement SW: DASY4, V4.6 Build 23; Postprocessing SW: SEMCAD, V1.8 Build 176

DASY4 Configuration:

- Probe: ET3DV6 - SN1798; ConvF(4.32, 4.32, 4.32); Calibrated: 2008-03-20
- Sensor-Surface: 4mm (Mechanical Surface Detection)
- Electronics: DAE4 Sn447; Calibrated: 2007-09-13
- Phantom: 1800/1900 Phantom; Type: SAM

WIFI 801.11b 6/Area Scan (101x111x1): Measurement grid: dx=15mm, dy=15mm[Info: Interpolated medium parameters used for SAR evaluation.](#)

Maximum value of SAR (interpolated) = 0.410 mW/g

WIFI 801.11b 6/Zoom Scan (5x5x7)/Cube 0: Measurement grid: dx=8mm, dy=8mm, dz=5mm

Reference Value = 5.64 V/m; Power Drift = -0.050 dB

Peak SAR (extrapolated) = 0.792 W/kg

SAR(1 g) = 0.384 mW/g; SAR(10 g) = 0.219 mW/g[Info: Interpolated medium parameters used for SAR evaluation.](#)

Maximum value of SAR (measured) = 0.396 mW/g

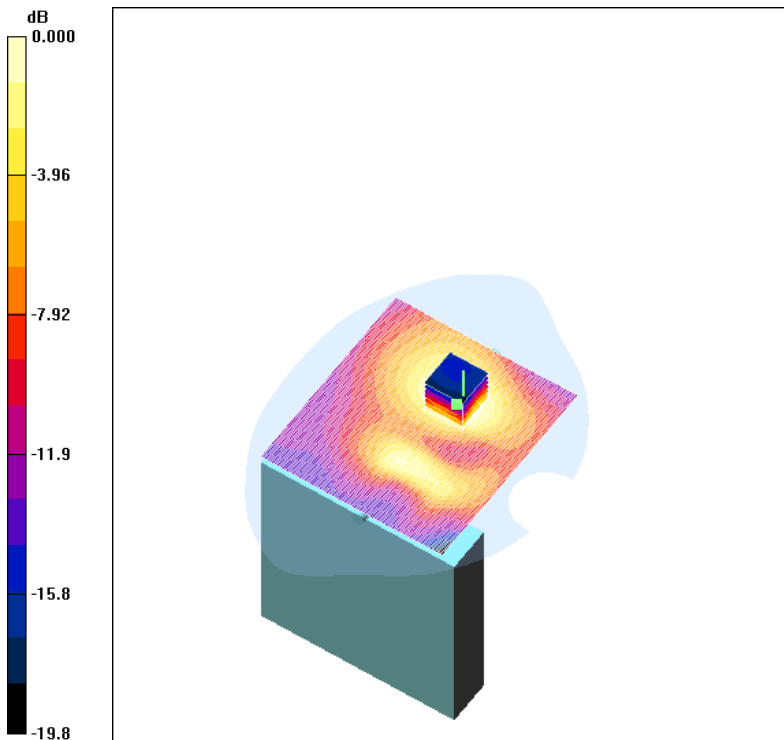

0 dB = 0.396mW/g

Test Laboratory: HCT CO., LTD
EUT Type: Cellular CDMA Wireless Gateway with WLAN
Liquid Temperature: 21.2 °C
Ambient Temperature: 21.4 °C
Test Date: July 16, 2008

DUT: MV420A; Type: CDMA WLL Phone; Serial:#1

Communication System: 2450MHz FCC; Frequency: 2462 MHz; Duty Cycle: 1:1
Medium parameters used (interpolated): $f = 2462$ MHz; $\sigma = 2.04$ mho/m; $\epsilon_r = 50.9$; $\rho = 1000$ kg/m³
Phantom section: Flat Section ; Measurement SW: DASY4, V4.6 Build 23; Postprocessing SW: SEMCAD, V1.8 Build 176

DASY4 Configuration:

- Probe: ET3DV6 - SN1798; ConvF(4.32, 4.32, 4.32); Calibrated: 2008-03-20
- Sensor-Surface: 4mm (Mechanical Surface Detection)
- Electronics: DAE4 Sn447; Calibrated: 2007-09-13
- Phantom: 1800/1900 Phantom; Type: SAM

WIFI 801.11b 11/Area Scan (101x111x1): Measurement grid: dx=15mm, dy=15mm

[Info: Interpolated medium parameters used for SAR evaluation.](#)

Maximum value of SAR (interpolated) = 0.405 mW/g

WIFI 801.11b 11/Zoom Scan (5x5x7)/Cube 0: Measurement grid: dx=8mm, dy=8mm, dz=5mm

Reference Value = 5.49 V/m; Power Drift = 0.059 dB

Peak SAR (extrapolated) = 0.812 W/kg

SAR(1 g) = 0.388 mW/g; SAR(10 g) = 0.220 mW/g

[Info: Interpolated medium parameters used for SAR evaluation.](#)

Maximum value of SAR (measured) = 0.398 mW/g

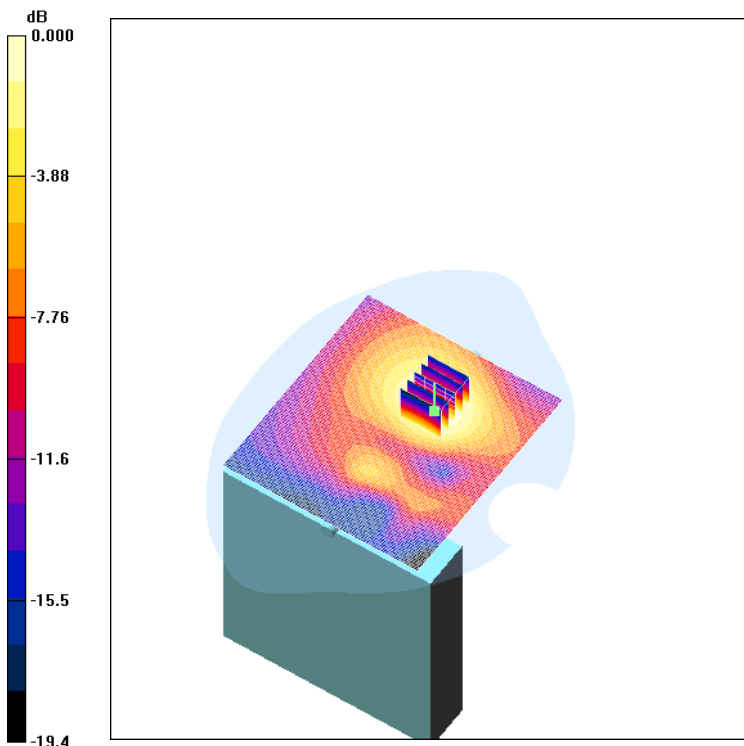

0 dB = 0.398mW/g

Test Laboratory: HCT CO., LTD
EUT Type: Cellular CDMA Wireless Gateway with WLAN
Liquid Temperature: 21.2 °C
Ambient Temperature: 21.4 °C
Test Date: July 16, 2008

DUT: MV420A; Type: CDMA WLL Phone; Serial:#1

Communication System: 2450MHz FCC; Frequency: 2412 MHz; Duty Cycle: 1:1
Medium parameters used (interpolated): $f = 2412$ MHz; $\sigma = 1.96$ mho/m; $\epsilon_r = 51.2$; $\rho = 1000$ kg/m³
Phantom section: Flat Section ; Measurement SW: DASY4, V4.6 Build 23; Postprocessing SW: SEMCAD, V1.8 Build 176

DASY4 Configuration:

- Probe: ET3DV6 - SN1798; ConvF(4.32, 4.32, 4.32); Calibrated: 2008-03-20
- Sensor-Surface: 4mm (Mechanical Surface Detection)
- Electronics: DAE4 Sn447; Calibrated: 2007-09-13
- Phantom: 1800/1900 Phantom; Type: SAM

WIFI 801.11g 1/Area Scan (101x111x1): Measurement grid: dx=15mm, dy=15mm

[Info: Interpolated medium parameters used for SAR evaluation.](#)

Maximum value of SAR (interpolated) = 0.223 mW/g

WIFI 801.11g 1/Zoom Scan (5x5x7)/Cube 0: Measurement grid: dx=8mm, dy=8mm, dz=5mm

Reference Value = 9.59 V/m; Power Drift = 0.019 dB

Peak SAR (extrapolated) = 0.439 W/kg

SAR(1 g) = 0.219 mW/g; SAR(10 g) = 0.119 mW/g

[Info: Interpolated medium parameters used for SAR evaluation.](#)

Maximum value of SAR (measured) = 0.236 mW/g

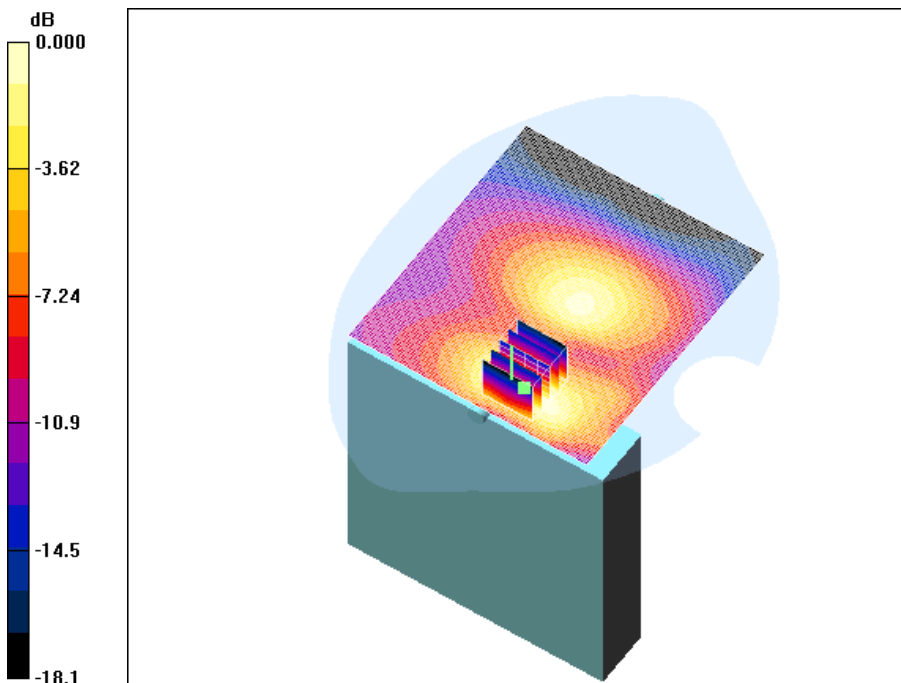

0 dB = 0.236mW/g

Test Laboratory: HCT CO., LTD
 EUT Type: Cellular CDMA Wireless Gateway with WLAN
 Liquid Temperature: 21.2 °C
 Ambient Temperature: 21.4 °C
 Test Date: July 14, 2008

DUT: MV420A; Type: CDMA WLL Phone; Serial:#1

Communication System: 2450MHz FCC; Frequency: 2437 MHz; Duty Cycle: 1:1
 Medium parameters used (interpolated): $f = 2437$ MHz; $\sigma = 2.01$ mho/m; $\epsilon_r = 51$; $\rho = 1000$ kg/m³
 Phantom section: Flat Section ; Measurement SW: DASY4, V4.6 Build 23; Postprocessing SW: SEMCAD, V1.8 Build 176

DASY4 Configuration:

- Probe: ET3DV6 - SN1798; ConvF(4.32, 4.32, 4.32); Calibrated: 2008-03-20
- Sensor-Surface: 4mm (Mechanical Surface Detection)
- Electronics: DAE4 Sn447; Calibrated: 2007-09-13
- Phantom: 1800/1900 Phantom; Type: SAM

WIFI 801.11g 6/Area Scan (101x111x1): Measurement grid: dx=15mm, dy=15mm

[Info: Interpolated medium parameters used for SAR evaluation.](#)

Maximum value of SAR (interpolated) = 0.266 mW/g

WIFI 801.11g 6/Zoom Scan (5x5x7)/Cube 0: Measurement grid: dx=8mm, dy=8mm, dz=5mm

Reference Value = 11.7 V/m; Power Drift = 0.031 dB

Peak SAR (extrapolated) = 0.489 W/kg

SAR(1 g) = 0.246 mW/g; SAR(10 g) = 0.143 mW/g

[Info: Interpolated medium parameters used for SAR evaluation.](#)

Maximum value of SAR (measured) = 0.253 mW/g

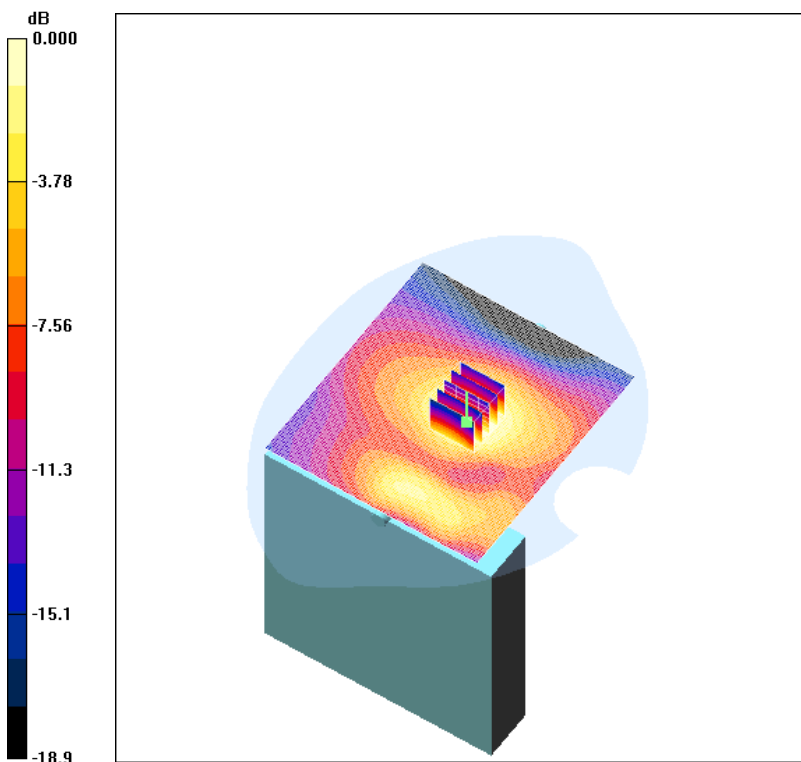

0 dB = 0.253mW/g

Test Laboratory: HCT CO., LTD
EUT Type: Cellular CDMA Wireless Gateway with WLAN
Liquid Temperature: 21.2 °C
Ambient Temperature: 21.4 °C
Test Date: July 16, 2008

DUT: MV420A; Type: CDMA WLL Phone; Serial:#1

Communication System: 2450MHz FCC; Frequency: 2462 MHz; Duty Cycle: 1:1
Medium parameters used (interpolated): $f = 2462$ MHz; $\sigma = 2.04$ mho/m; $\epsilon_r = 50.9$; $\rho = 1000$ kg/m³
Phantom section: Flat Section ; Measurement SW: DASY4, V4.6 Build 23; Postprocessing SW: SEMCAD, V1.8 Build 176

DASY4 Configuration:

- Probe: ET3DV6 - SN1798; ConvF(4.32, 4.32, 4.32); Calibrated: 2008-03-20
- Sensor-Surface: 4mm (Mechanical Surface Detection)
- Electronics: DAE4 Sn447; Calibrated: 2007-09-13
- Phantom: 1800/1900 Phantom; Type: SAM

WIFI 801.11g 11/Area Scan (101x111x1): Measurement grid: dx=15mm, dy=15mm[Info: Interpolated medium parameters used for SAR evaluation.](#)

Maximum value of SAR (interpolated) = 0.220 mW/g

WIFI 801.11g 11/Zoom Scan (5x5x7)/Cube 0: Measurement grid: dx=8mm, dy=8mm, dz=5mm

Reference Value = 4.07 V/m; Power Drift = 0.112 dB

Peak SAR (extrapolated) = 0.443 W/kg

SAR(1 g) = 0.210 mW/g; SAR(10 g) = 0.119 mW/g[Info: Interpolated medium parameters used for SAR evaluation.](#)

Maximum value of SAR (measured) = 0.219 mW/g

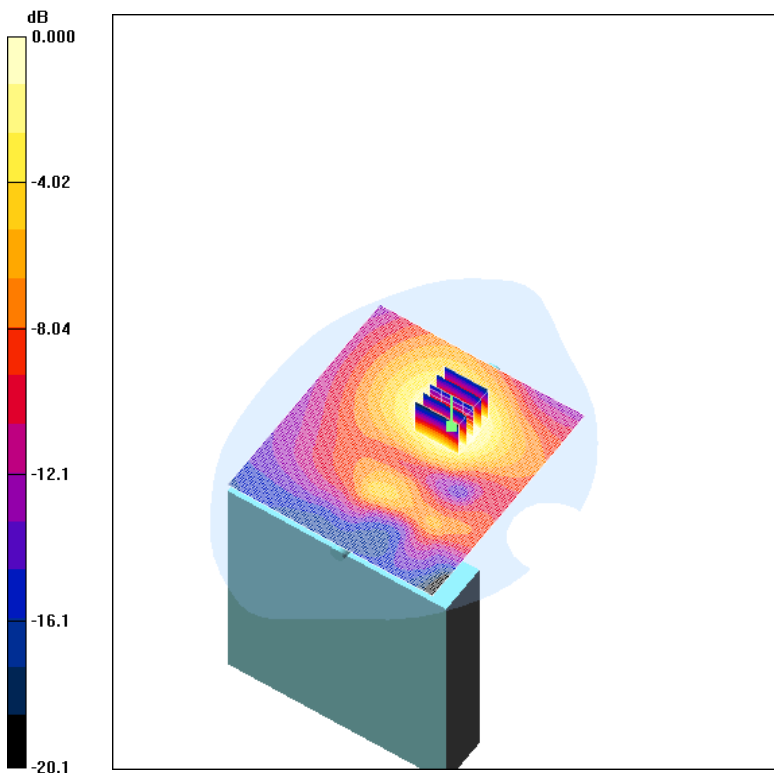

0 dB = 0.219mW/g

Test Laboratory: HCT CO., LTD
EUT Type: Cellular CDMA Wireless Gateway with WLAN
Liquid Temperature: 21.2 °C
Ambient Temperature: 21.4 °C
Test Date: July 16, 2008
Option: Standard Battery

DUT: MV420A; Type: CDMA WLL Phone; Serial:#1

Communication System: 2450MHz FCC; Frequency: 2412 MHz; Duty Cycle: 1:1
Medium parameters used (interpolated): $f = 2412$ MHz; $\sigma = 1.96$ mho/m; $\epsilon_r = 51.2$; $\rho = 1000$ kg/m³
Phantom section: Flat Section ; Measurement SW: DASY4, V4.6 Build 23; Postprocessing SW: SEMCAD, V1.8 Build 176

DASY4 Configuration:

- Probe: ET3DV6 - SN1798; ConvF(4.32, 4.32, 4.32); Calibrated: 2008-03-20
- Sensor-Surface: 4mm (Mechanical Surface Detection)
- Electronics: DAE4 Sn447; Calibrated: 2007-09-13
- Phantom: 835/900 Phantom ; Type: SAM

WIFI 802.11b 1/Area Scan (101x111x1): Measurement grid: dx=15mm, dy=15mm

[Info: Interpolated medium parameters used for SAR evaluation.](#)

Maximum value of SAR (interpolated) = 0.276 mW/g

WIFI 802.11b 1/Zoom Scan (5x5x7)/Cube 0: Measurement grid: dx=8mm, dy=8mm, dz=5mm

Reference Value = 10.5 V/m; Power Drift = 0.144 dB

Peak SAR (extrapolated) = 0.536 W/kg

SAR(1 g) = 0.249 mW/g; SAR(10 g) = 0.138 mW/g

[Info: Interpolated medium parameters used for SAR evaluation.](#)

Maximum value of SAR (measured) = 0.257 mW/g

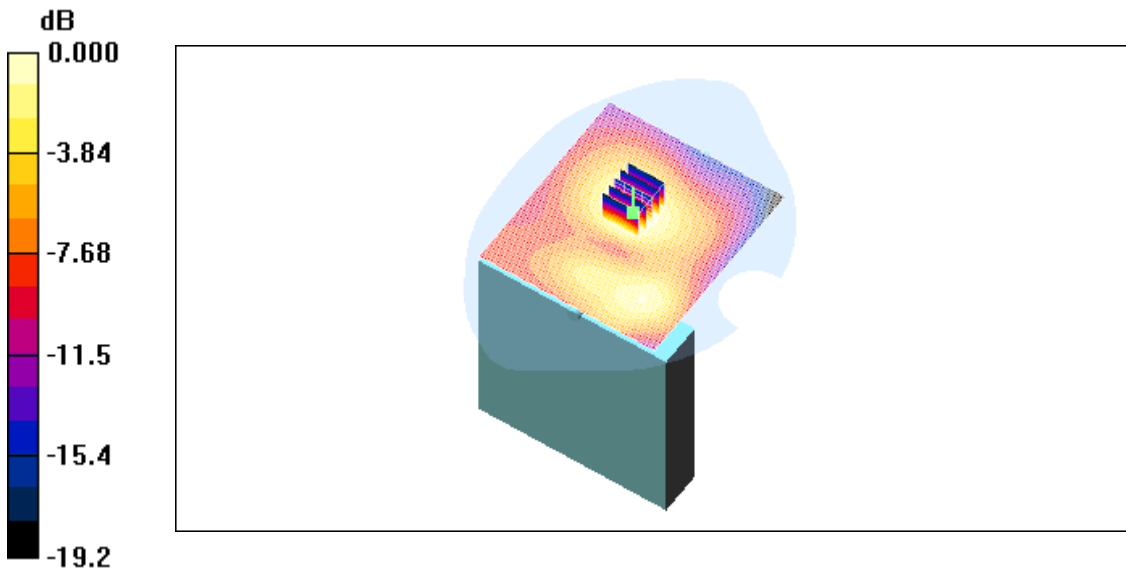

0 dB = 0.257mW/g

Test Laboratory: HCT CO., LTD
 EUT Type: Cellular CDMA Wireless Gateway with WLAN
 Liquid Temperature: 21.2 °C
 Ambient Temperature: 21.4 °C
 Test Date: July 14, 2008
 Option: EVDO

DUT: MV420A; Type: CDMA WLL Phone; Serial:#1

Communication System: CDMA 835MHz FCC; Frequency: 836.52 MHz; Duty Cycle: 1:1
 Medium parameters used (interpolated): $f = 836.52 \text{ MHz}$; $\sigma = 0.992 \text{ mho/m}$; $\epsilon_r = 55.7$; $\rho = 1000 \text{ kg/m}^3$
 Phantom section: Flat Section ; Measurement SW: DASY4, V4.6 Build 23; Postprocessing SW: SEMCAD, V1.8 Build 176

DASY4 Configuration:

- Probe: ET3DV6 - SN1798; ConvF(6.29, 6.29, 6.29); Calibrated: 2008-03-20
- Sensor-Surface: 4mm (Mechanical Surface Detection)
- Electronics: DAE4 Sn447; Calibrated: 2007-09-13
- Phantom: 835/900 Phantom ; Type: SAM

Body CDMA 384/Area Scan (101x111x1): Measurement grid: dx=15mm, dy=15mm

[Info: Interpolated medium parameters used for SAR evaluation.](#)

Maximum value of SAR (interpolated) = 0.768 mW/g

Body CDMA 384/Zoom Scan (5x5x7)/Cube 0: Measurement grid: dx=8mm, dy=8mm, dz=5mm

Reference Value = 27.6 V/m; Power Drift = 0.097 dB

Peak SAR (extrapolated) = 0.956 W/kg

SAR(1 g) = 0.731 mW/g; SAR(10 g) = 0.522 mW/g

[Info: Interpolated medium parameters used for SAR evaluation.](#)

Maximum value of SAR (measured) = 0.775 mW/g

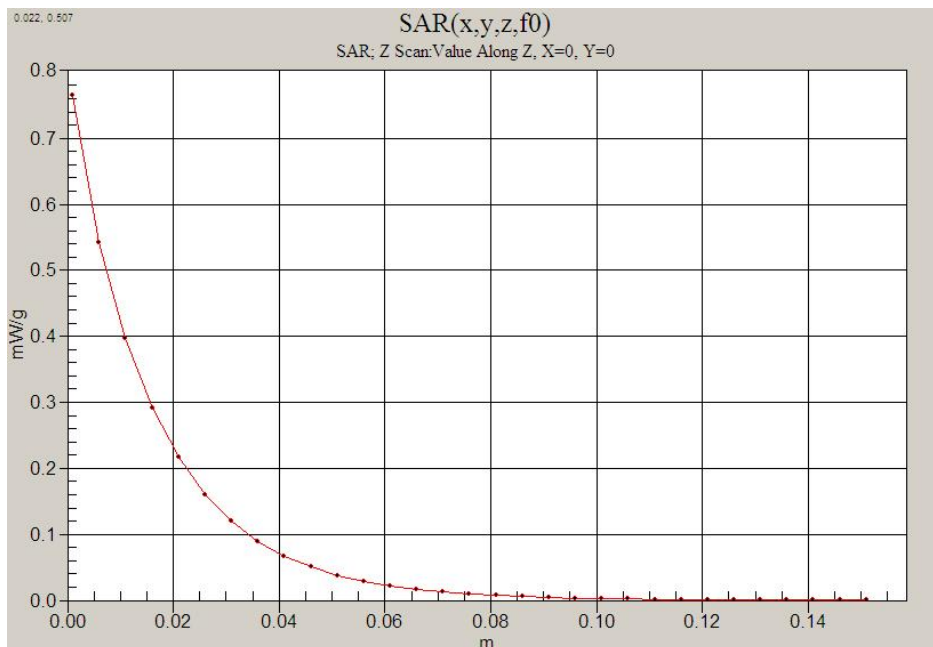

Test Laboratory: HCT CO., LTD
EUT Type: Cellular CDMA Wireless Gateway with WLAN
Liquid Temperature: 21.2 °C
Ambient Temperature: 21.4 °C
Test Date: July 16, 2008

DUT: MV420A; Type: CDMA WLL Phone; Serial:#1

Communication System: 2450MHz FCC; Frequency: 2412 MHz; Duty Cycle: 1:1
Medium parameters used (interpolated): $f = 2412$ MHz; $\sigma = 1.96$ mho/m; $\epsilon_r = 51.2$; $\rho = 1000$ kg/m³
Phantom section: Flat Section ; Measurement SW: DASY4, V4.6 Build 23; Postprocessing SW: SEMCAD, V1.8 Build 176

DASY4 Configuration:

- Probe: ET3DV6 - SN1798; ConvF(4.32, 4.32, 4.32); Calibrated: 2008-03-20
- Sensor-Surface: 4mm (Mechanical Surface Detection)
- Electronics: DAE4 Sn447; Calibrated: 2007-09-13
- Phantom: 1800/1900 Phantom; Type: SAM

WIFI 801.11b 1/Area Scan (101x111x1): Measurement grid: dx=15mm, dy=15mm

[Info: Interpolated medium parameters used for SAR evaluation.](#)

Maximum value of SAR (interpolated) = 0.474 mW/g

WIFI 801.11b 1/Zoom Scan (5x5x7)/Cube 0: Measurement grid: dx=8mm, dy=8mm, dz=5mm

Reference Value = 6.50 V/m; Power Drift = -0.126 dB

Peak SAR (extrapolated) = 0.937 W/kg

SAR(1 g) = 0.444 mW/g; SAR(10 g) = 0.235 mW/g

[Info: Interpolated medium parameters used for SAR evaluation.](#)

Maximum value of SAR (measured) = 0.476 mW/g

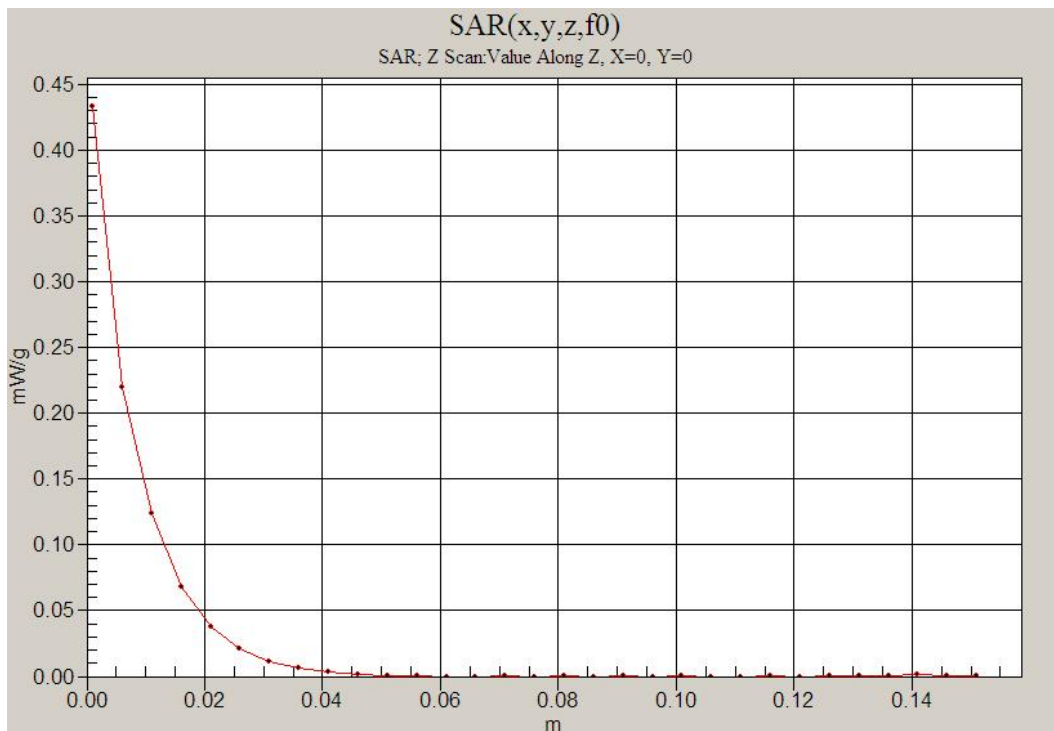

Attachment 2. – Dipole Validation Plots

■ Validation Data (835 MHz Head)

Test Laboratory: HCT CO., LTD
Input Power 1W (30dBm)
Liquid Temp: 21.2 °C
Test Date: July 14, 2008

DUT: Dipole 835 MHz; Serial: D835V2 – SN:441

Communication System: CW; Frequency: 835 MHz; Duty Cycle: 1:1
Medium parameters used: $f = 835$ MHz; $\sigma = 0.883$ mho/m; $\epsilon_r = 41.4$; $\rho = 1000$ kg/m³
Phantom section: Flat Section ; Measurement SW: DASY4, V4.6 Build 23; Postprocessing SW: SEMCAD, V1.8 Build 176

DASY4 Configuration:

- Probe: ET3DV6 – SN1798; ConvF(6.79, 6.79, 6.79); Calibrated: 2008-03-20
- Sensor-Surface: 4mm (Mechanical Surface Detection)
- Electronics: DAE4 Sn447; Calibrated: 2007-09-13
- Phantom: 835/900 Phantom ; Type: SAM

Validation 835 MHz/Area Scan (61x81x1): Measurement grid: dx=15mm, dy=15mm

Maximum value of SAR (interpolated) = 10.3 mW/g

Validation 835 MHz/Zoom Scan (5x5x7)/Cube 0: Measurement grid: dx=8mm, dy=8mm, dz=5mm

Reference Value = 110.3 V/m; Power Drift = -0.005 dB

Peak SAR (extrapolated) = 13.9 W/kg

SAR(1 g) = 9.49 mW/g; SAR(10 g) = 6.22 mW/g

Maximum value of SAR (measured) = 10.3 mW/g

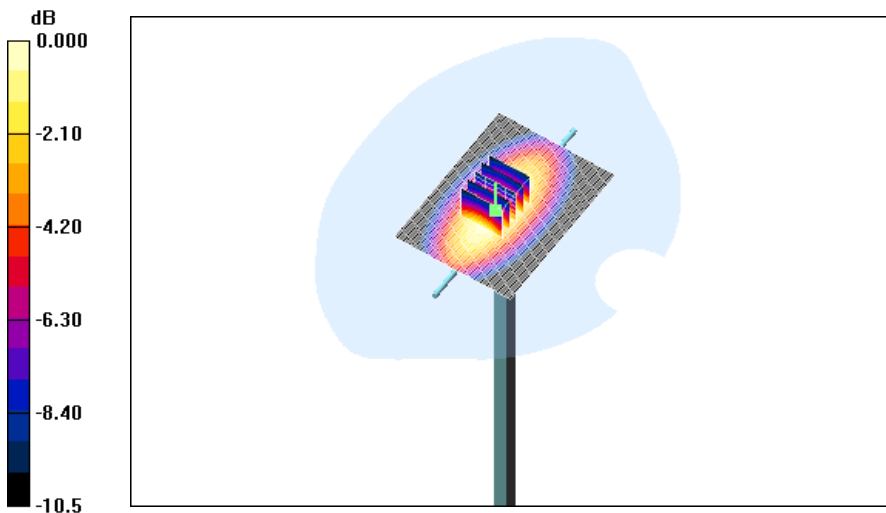

0 dB = 10.3mW/g

■ Validation Data (2450 MHz Head)

Test Laboratory: HCT CO., LTD
Input Power 1W (30dBm)
Liquid Temp: 21.2 °C
Test Date: July 16, 2008

DUT: Dipole 2450 MHz; Serial: D2450V2 - SN:734

Communication System: CW; Frequency: 2450 MHz; Duty Cycle: 1:1
Medium parameters used: $f = 2450$ MHz; $\sigma = 1.81$ mho/m; $\epsilon_r = 38.7$; $\rho = 1000$ kg/m³
Phantom section: Flat Section ; Measurement SW: DASY4, V4.6 Build 23; Postprocessing SW: SEMCAD, V1.8 Build 176

DASY4 Configuration:

- Probe: ET3DV6 - SN1798; ConvF(4.81, 4.81, 4.81); Calibrated: 2008-03-20
- Sensor-Surface: 4mm (Mechanical Surface Detection)
- Electronics: DAE4 Sn447; Calibrated: 2007-09-13
- Phantom: 1800/1900 Phantom; Type: SAM

Validation 2450MHz/Area Scan (61x61x1): Measurement grid: dx=15mm, dy=15mm
Maximum value of SAR (interpolated) = 65.9 mW/g

Validation 2450MHz/Zoom Scan (5x5x7)/Cube 0: Measurement grid: dx=8mm, dy=8mm, dz=5mm
Reference Value = 176.9 V/m; Power Drift = -0.036 dB
Peak SAR (extrapolated) = 135.9 W/kg
SAR(1 g) = 54.2 mW/g; SAR(10 g) = 23.9 mW/g
Maximum value of SAR (measured) = 58.5 mW/g

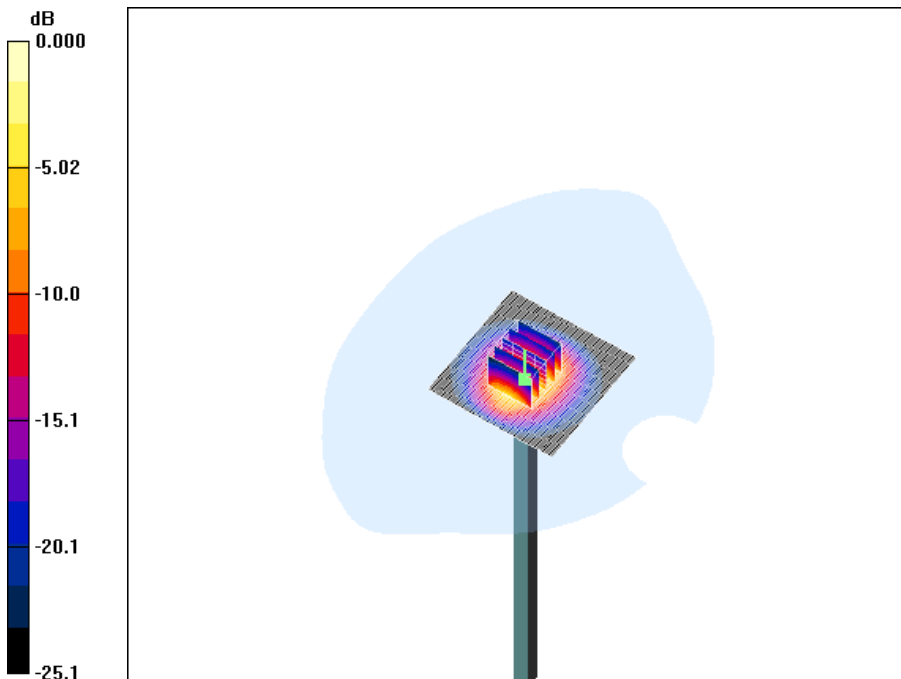

0 dB = 58.5mW/g

■ Dielectric Parameter (835 MHz Head)

Title MV420A
SubTitle CDMA835(Head)
Test Date July 14, 2008

Frequency	e'	e''
800000000	41.7245	19.0205
805000000	41.6896	19.0139
810000000	41.6254	19.0153
815000000	41.5497	19.0093
820000000	41.5092	18.9726
825000000	41.4858	18.9951
830000000	41.4737	18.9985
835000000	41.4357	19.0195
840000000	41.3632	19.0447
845000000	41.3719	18.9846
850000000	41.3875	18.9851
855000000	41.3482	18.9906
860000000	41.2887	18.9763
865000000	41.2591	18.9741
870000000	41.1966	18.9611
875000000	41.1716	18.9173
880000000	41.1035	18.8965
885000000	41.0759	18.8743
890000000	40.9944	18.8532
895000000	40.9223	18.8099
900000000	40.8555	18.8151

■ Dielectric Parameter (835 MHz Body)

Title MV420A
SubTitle CDMA835(Body)
Test Date July 14, 2008

Frequency	e'	e''
800000000	56.2579	21.4418
805000000	56.2188	21.4561
810000000	56.1236	21.4227
815000000	56.0616	21.3833
820000000	55.9551	21.3272
825000000	55.8949	21.3612
830000000	55.8146	21.3524
835000000	55.7417	21.3300
840000000	55.6683	21.3028
845000000	55.6226	21.2874
850000000	55.5816	21.2813
855000000	55.5069	21.2556
860000000	55.4661	21.2444
865000000	55.3934	21.2457
870000000	55.3072	21.2364
875000000	55.2615	21.1900
880000000	55.2700	21.1976
885000000	55.1752	21.1446
890000000	55.1705	21.1413
895000000	55.0597	21.0695
900000000	55.0321	21.0705

■ Dielectric Parameter (2450 MHz Head)

Title MV420A
SubTitle PCS 1900(Head)
Test Date July 16, 2008

Frequency	e'	e''
2400000000	39.0025	13.1157
2405000000	38.9873	13.1009
2410000000	38.9643	13.1065
2415000000	38.9221	13.1254
2420000000	38.8556	13.1149
2425000000	38.6423	13.0835
2430000000	38.6012	13.0661
2435000000	38.6265	13.1315
2440000000	38.7139	13.1918
2445000000	38.7563	13.2373
2450000000	38.7186	13.2726
2455000000	38.6868	13.2948
2460000000	38.6859	13.3434
2465000000	38.6965	13.3464
2470000000	38.6537	13.4003
2475000000	38.6230	13.3997
2480000000	38.6218	13.4238
2485000000	38.5967	13.4325
2490000000	38.5458	13.4495
2495000000	38.5415	13.4433
2500000000	38.5912	13.4516

■ Dielectric Parameter (2450 MHz Body)

Title MV420A
SubTitle PCS 1900(Body)
Test Date July 16, 2008

Frequency	e'	e''
2400000000	51.2918	14.6605
2405000000	51.2540	14.6530
2410000000	51.2401	14.5981
2415000000	51.1946	14.6595
2420000000	51.1331	14.7256
2425000000	51.0681	14.7372
2430000000	51.0796	14.7444
2435000000	51.0300	14.7860
2440000000	51.0113	14.8193
2445000000	50.9774	14.8790
2450000000	50.9430	14.8988
2455000000	50.9469	14.9014
2460000000	50.9267	14.8932
2465000000	50.9106	14.9208
2470000000	50.8950	14.9516
2475000000	50.8625	15.0073
2480000000	50.8408	15.0385
2485000000	50.8111	15.0837
2490000000	50.7886	15.1165
2495000000	50.7877	15.1336
2500000000	50.7892	15.1553

Attachment 3. – Probe Calibration Data

**Calibration Laboratory of
Schmid & Partner
Engineering AG**
Zeughausstrasse 43, 8004 Zurich, Switzerland



S Schweizerischer Kalibrierdienst
C Service suisse d'étalonnage
S Servizio svizzero di taratura
S Swiss Calibration Service

Accredited by the Swiss Accreditation Service (SAS)
The Swiss Accreditation Service is one of the signatories to the EA
Multilateral Agreement for the recognition of calibration certificates

Accreditation No.: **SCS 108**

Client **HCT (Dymstec)**

Certificate No: **ET3-1798_Mar08**

CALIBRATION CERTIFICATE

Object **ET3DV6 - SN:1798**

Calibration procedure(s) **QA CAL-01.v6
Calibration procedure for dosimetric E-field probes**

Calibration date: **March 20, 2008**

Condition of the calibrated item **In Tolerance**

This calibration certificate documents the traceability to national standards, which realize the physical units of measurements (SI).
The measurements and the uncertainties with confidence probability are given on the following pages and are part of the certificate.

All calibrations have been conducted in the closed laboratory facility: environment temperature (22 ± 3)°C and humidity < 70%.

Calibration Equipment used (M&TE critical for calibration)

Primary Standards	ID #	Cal Date (Calibrated by, Certificate No.)	Scheduled Calibration
Power meter E4419B	GB41293874	29-Mar-07 (METAS, No. 217-00670)	Mar-08
Power sensor E4412A	MY41495277	29-Mar-07 (METAS, No. 217-00670)	Mar-08
Power sensor E4412A	MY41498087	29-Mar-07 (METAS, No. 217-00670)	Mar-08
Reference 3 dB Attenuator	SN: S5054 (3c)	8-Aug-07 (METAS, No. 217-00719)	Aug-08
Reference 20 dB Attenuator	SN: S5086 (20b)	29-Mar-07 (METAS, No. 217-00671)	Mar-08
Reference 30 dB Attenuator	SN: S5129 (30b)	8-Aug-07 (METAS, No. 217-00720)	Aug-08
Reference Probe ES3DV2	SN: 3013	2-Jan-08 (SPEAG, No. ES3-3013_Jan08)	Jan-09
DAE4	SN: 654	20-Apr-07 (SPEAG, No. DAE4-654_Apr07)	Apr-08
Secondary Standards	ID #	Check Date (In house)	Scheduled Check
RF generator HP 8648C	US3642U01700	4-Aug-99 (SPEAG, in house check Oct-07)	In house check: Oct-09
Network Analyzer HP 8753E	US37390585	18-Oct-01 (SPEAG, in house check Oct-07)	In house check: Oct-08

	Name	Function	Signature
Calibrated by:	Katja Pokovic	Technical Manager	
Approved by:	Niels Kuster	Quality Manager	

Issued: March 21, 2008

This calibration certificate shall not be reproduced except in full without written approval of the laboratory.

**Calibration Laboratory of
Schmid & Partner
Engineering AG**
Zeughausstrasse 43, 8004 Zurich, Switzerland



S Schweizerischer Kalibrierdienst
C Service suisse d'étalonnage
S Servizio svizzero di taratura
S Swiss Calibration Service

Accredited by the Swiss Accreditation Service (SAS)
The Swiss Accreditation Service is one of the signatories to the EA
Multilateral Agreement for the recognition of calibration certificates

Accreditation No.: **SCS 108**

Glossary:

TSL	tissue simulating liquid
NORM _{x,y,z}	sensitivity in free space
ConvF	sensitivity in TSL / NORM _{x,y,z}
DCP	diode compression point
Polarization φ	φ rotation around probe axis
Polarization ϑ	ϑ rotation around an axis that is in the plane normal to probe axis (at measurement center), i.e., $\vartheta = 0$ is normal to probe axis

Calibration is Performed According to the Following Standards:

- IEEE Std 1528-2003, "IEEE Recommended Practice for Determining the Peak Spatial-Averaged Specific Absorption Rate (SAR) in the Human Head from Wireless Communications Devices: Measurement Techniques", December 2003
- IEC 62209-1, "Procedure to measure the Specific Absorption Rate (SAR) for hand-held devices used in close proximity to the ear (frequency range of 300 MHz to 3 GHz)", February 2005

Methods Applied and Interpretation of Parameters:

- NORM_{x,y,z}:** Assessed for E-field polarization $\vartheta = 0$ ($f \leq 900$ MHz in TEM-cell; $f > 1800$ MHz: R22 waveguide). NORM_{x,y,z} are only intermediate values, i.e., the uncertainties of NORM_{x,y,z} does not effect the E²-field uncertainty inside TSL (see below ConvF).
- NORM(f)_{x,y,z} = NORM_{x,y,z} * frequency_response** (see Frequency Response Chart). This linearization is implemented in DASY4 software versions later than 4.2. The uncertainty of the frequency response is included in the stated uncertainty of ConvF.
- DCP_{x,y,z}:** DCP are numerical linearization parameters assessed based on the data of power sweep (no uncertainty required). DCP does not depend on frequency nor media.
- ConvF and Boundary Effect Parameters:** Assessed in flat phantom using E-field (or Temperature Transfer Standard for $f \leq 800$ MHz) and inside waveguide using analytical field distributions based on power measurements for $f > 800$ MHz. The same setups are used for assessment of the parameters applied for boundary compensation (alpha, depth) of which typical uncertainty values are given. These parameters are used in DASY4 software to improve probe accuracy close to the boundary. The sensitivity in TSL corresponds to NORM_{x,y,z} * ConvF whereby the uncertainty corresponds to that given for ConvF. A frequency dependent ConvF is used in DASY version 4.4 and higher which allows extending the validity from ± 50 MHz to ± 100 MHz.
- Spherical isotropy (3D deviation from isotropy):** in a field of low gradients realized using a flat phantom exposed by a patch antenna.
- Sensor Offset:** The sensor offset corresponds to the offset of virtual measurement center from the probe tip (on probe axis). No tolerance required.

ET3DV6 SN:1798

March 20, 2008

Probe ET3DV6

SN:1798

Manufactured:	August 14, 2003
Last calibrated:	August 25, 2006
Recalibrated:	March 20, 2008

Calibrated for DASY Systems

(Note: non-compatible with DASY2 system!)

ET3DV6 SN:1798

March 20, 2008

DASY - Parameters of Probe: ET3DV6 SN:1798

Sensitivity in Free Space^A

Diode Compression^B

NormX	1.97 ± 10.1%	μV/(V/m) ²	DCP X	93 mV
NormY	1.84 ± 10.1%	μV/(V/m) ²	DCP Y	93 mV
NormZ	2.00 ± 10.1%	μV/(V/m) ²	DCP Z	94 mV

Sensitivity in Tissue Simulating Liquid (Conversion Factors)

Please see Page 8.

Boundary Effect

TSL 900 MHz Typical SAR gradient: 5 % per mm

Sensor Center to Phantom Surface Distance		3.7 mm	4.7 mm
SAR _{iso} [%]	Without Correction Algorithm	9.5	5.7
SAR _{iso} [%]	With Correction Algorithm	0.8	0.7

TSL 1810 MHz Typical SAR gradient: 10 % per mm

Sensor Center to Phantom Surface Distance		3.7 mm	4.7 mm
SAR _{iso} [%]	Without Correction Algorithm	12.4	7.8
SAR _{iso} [%]	With Correction Algorithm	0.9	0.8

Sensor Offset

Probe Tip to Sensor Center 2.7 mm

The reported uncertainty of measurement is stated as the standard uncertainty of measurement multiplied by the coverage factor k=2, which for a normal distribution corresponds to a coverage probability of approximately 95%.

^A The uncertainties of NormX,Y,Z do not affect the E²-field uncertainty inside TSL (see Page 8).

^B Numerical linearization parameter: uncertainty not required.

ET3DV6 SN:1798

March 20, 2008

Frequency Response of E-Field

(TEM-Cell:ifi110 EXX, Waveguide: R22)

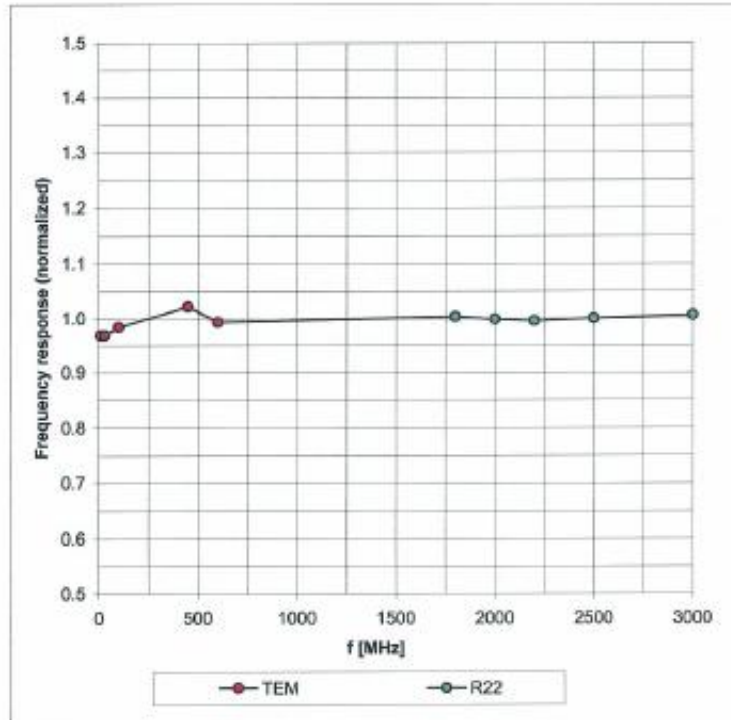

Uncertainty of Frequency Response of E-field: $\pm 6.3\%$ ($k=2$)

ET3DV6 SN:1798

March 20, 2008

Receiving Pattern (ϕ), $\theta = 0^\circ$

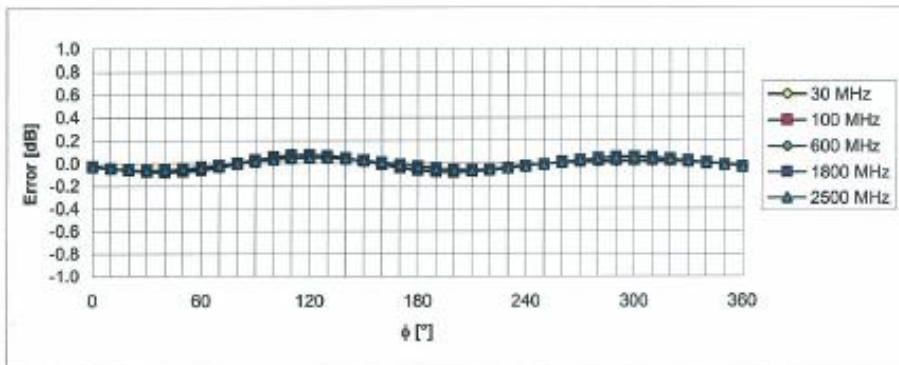
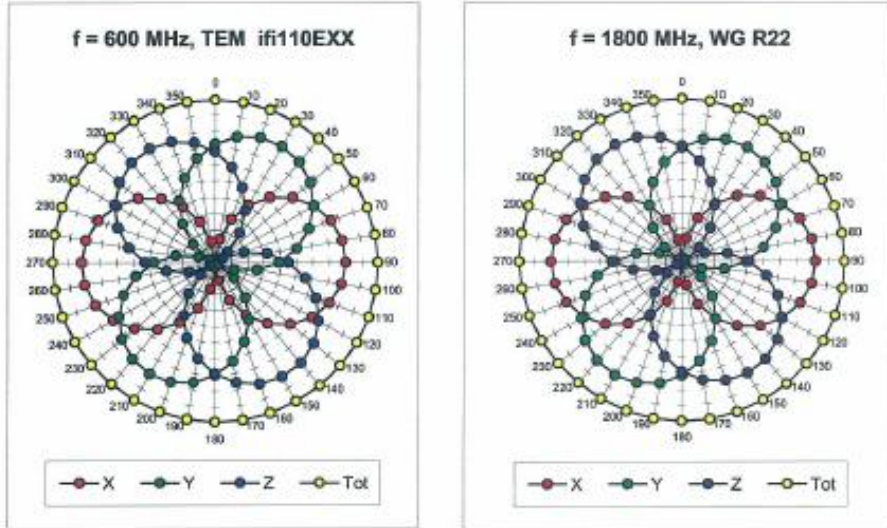

Uncertainty of Axial Isotropy Assessment: $\pm 0.5\%$ (k=2)

ET3DV6 SN:1798

March 20, 2008

Dynamic Range f(SAR_{head})
(Waveguide R22, f = 1800 MHz)

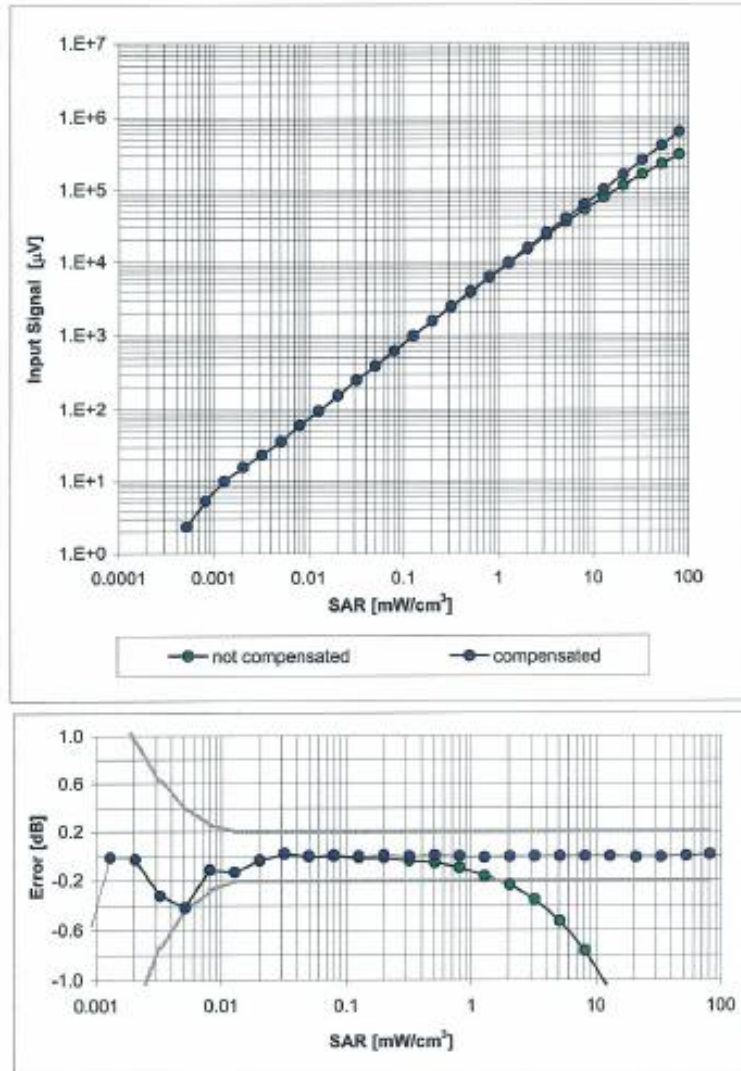

Uncertainty of Linearity Assessment: ± 0.6% (k=2)

ET3DV6 SN:1798

March 20, 2008

Conversion Factor Assessment

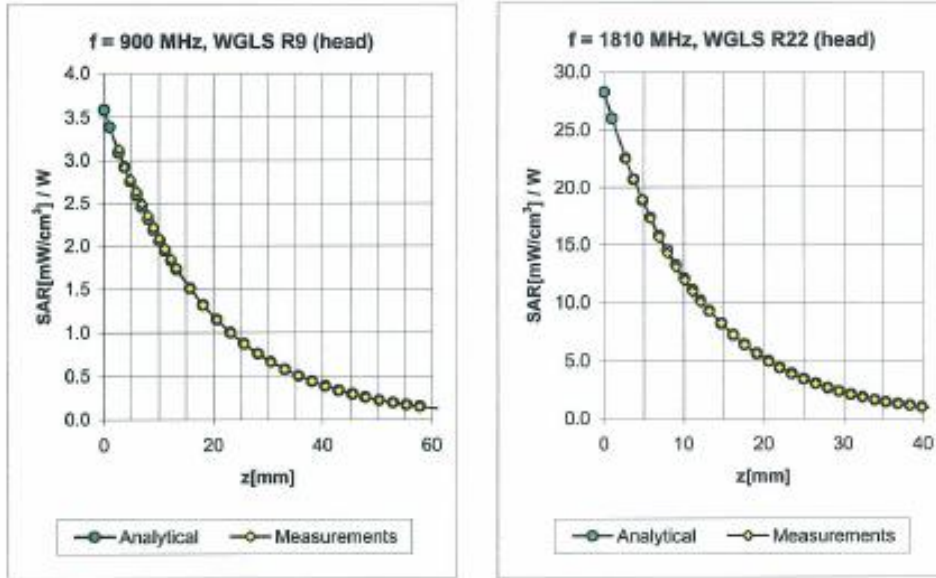

f [MHz]	Validity [MHz] ^c	TSL	Permittivity	Conductivity	Alpha	Depth	ConvF Uncertainty
900	± 50 / ± 100	Head	41.5 ± 5%	0.97 ± 5%	0.78	1.68	6.79 ± 11.0% (k=2)
1810	± 50 / ± 100	Head	40.0 ± 5%	1.40 ± 5%	0.50	2.40	5.58 ± 11.0% (k=2)
1950	± 50 / ± 100	Head	40.0 ± 5%	1.40 ± 5%	0.48	2.50	5.24 ± 11.0% (k=2)
2450	± 50 / ± 100	Head	39.2 ± 5%	1.80 ± 5%	0.95	1.40	4.81 ± 11.8% (k=2)
835	± 50 / ± 100	Body	55.2 ± 5%	0.97 ± 5%	0.92	1.59	6.29 ± 11.0% (k=2)
1810	± 50 / ± 100	Body	53.3 ± 5%	1.52 ± 5%	0.53	2.31	5.38 ± 11.0% (k=2)
2450	± 50 / ± 100	Body	52.7 ± 5%	1.95 ± 5%	0.73	1.76	4.32 ± 11.8% (k=2)

^c The validity of ± 100 MHz only applies for DASY v4.4 and higher (see Page 2). The uncertainty is the RSS of the ConvF uncertainty at calibration frequency and the uncertainty for the indicated frequency band.

ET3DV6 SN:1798

March 20, 2008

Deviation from Isotropy in HSL Error (ϕ , θ), $f = 900$ MHz

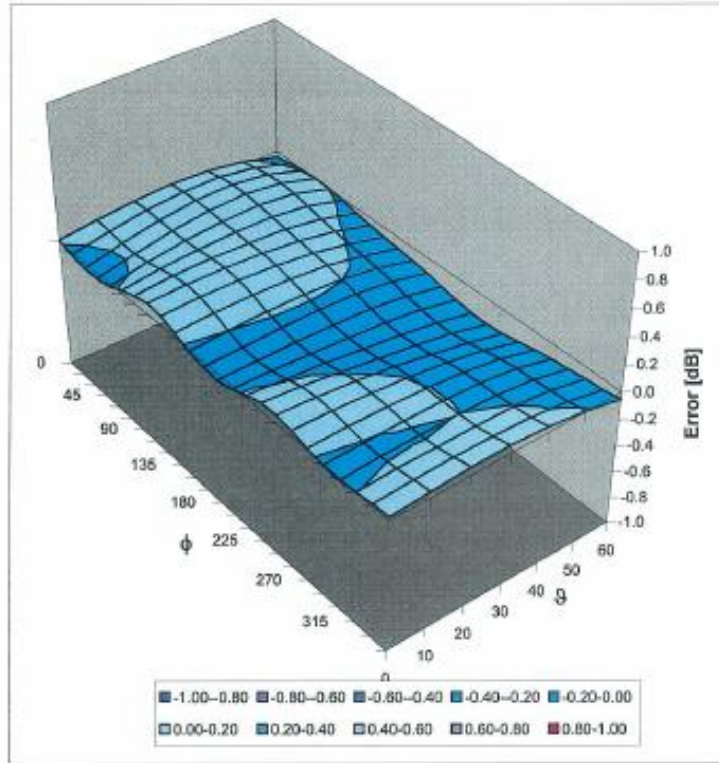

Uncertainty of Spherical Isotropy Assessment: $\pm 2.6\%$ ($k=2$)

Attachment 4. – Dipole Calibration Data

**Calibration Laboratory of
Schmid & Partner
Engineering AG**
Zeughausstrasse 43, 8004 Zurich, Switzerland



S Schweizerischer Kalibrierdienst
C Service suisse d'étalonnage
S Servizio svizzero di taratura
S Swiss Calibration Service

Accredited by the Swiss Accreditation Service (SAS)
The Swiss Accreditation Service is one of the signatories to the EA
Multilateral Agreement for the recognition of calibration certificates

Accreditation No.: **SCS 108**

Client **HCT (Dymstec)**

Certificate No: **D835V2-441_May08**

CALIBRATION CERTIFICATE

Object: **D835V2 - SN: 441**

Calibration procedure(s): **QA CAL-05.v7
Calibration procedure for dipole validation kits**

Calibration date: **May 19, 2008**

Condition of the calibrated item: **In Tolerance**

This calibration certificate documents the traceability to national standards, which realize the physical units of measurements (SI).
The measurements and the uncertainties with confidence probability are given on the following pages and are part of the certificate.

All calibrations have been conducted in the closed laboratory facility: environment temperature (22 ± 3)°C and humidity < 70%.

Calibration Equipment used (M&TE critical for calibration)

Primary Standards	ID #	Cal Date (Calibrated by, Certificate No.)	Scheduled Calibration
Power meter EPM-442A	GB37480704	04-Oct-07 (METAS, No. 217-00736)	Oct-08
Power sensor HP 8481A	US37292783	04-Oct-07 (METAS, No. 217-00736)	Oct-08
Reference 20 dB Attenuator	SN: 5086 (20g)	07-Aug-07 (METAS, No 217-00718)	Aug-08
Type-N mismatch combination	SN: 5047.2 / 06327	08-Aug-07 (No. 217-00721)	Aug-08
Reference Probe ES3DV2	SN: 3025	28-Apr-08 (No. ES3-3025_Apr08)	Apr-09
DAE4	SN: 601	14-Mar-08 (No. DAE4-601_Mar08)	Mar-09
Secondary Standards	ID #	Check Date (in house)	Scheduled Check
Power sensor HP 8481A	MY41092317	18-Oct-02 (SPEAG, in house check Oct-07)	In house check: Oct-09
RF generator R&S SMT-06	100005	04-Aug-99 (SPEAG, in house check Oct-07)	In house check: Oct-09
Network Analyzer HP 8753E	US37390585 S4206	18-Oct-01 (SPEAG, in house check Oct-07)	In house check: Oct-08

	Name	Function	Signature
Calibrated by:	Claudio Leubler	Laboratory Technician	
Approved by:	Katja Pokovic	Technical Manager	

Issued: May 20, 2008

This calibration certificate shall not be reproduced except in full without written approval of the laboratory.

Calibration Laboratory of
Schmid & Partner
Engineering AG
Zeughausstrasse 43, 8004 Zurich, Switzerland



S Schweizerischer Kalibrierdienst
C Service suisse d'étalonnage
S Servizio svizzero di taratura
S Swiss Calibration Service

Accredited by the Swiss Accreditation Service (SAS)
The Swiss Accreditation Service is one of the signatories to the EA
Multilateral Agreement for the recognition of calibration certificates

Accreditation No.: **SCS 108**

Glossary:

TSL tissue simulating liquid
ConvF sensitivity in TSL / NORM x,y,z
N/A not applicable or not measured

Calibration is Performed According to the Following Standards:

- a) IEEE Std 1528-2003, "IEEE Recommended Practice for Determining the Peak Spatial-Averaged Specific Absorption Rate (SAR) in the Human Head from Wireless Communications Devices: Measurement Techniques", December 2003
- b) IEC 62209-1, "Procedure to measure the Specific Absorption Rate (SAR) for hand-held devices used in close proximity to the ear (frequency range of 300 MHz to 3 GHz)", February 2005
- c) Federal Communications Commission Office of Engineering & Technology (FCC OET), "Evaluating Compliance with FCC Guidelines for Human Exposure to Radiofrequency Electromagnetic Fields; Additional Information for Evaluating Compliance of Mobile and Portable Devices with FCC Limits for Human Exposure to Radiofrequency Emissions", Supplement C (Edition 01-01) to Bulletin 65

Additional Documentation:

- d) DASY4/5 System Handbook

Methods Applied and Interpretation of Parameters:

- *Measurement Conditions:* Further details are available from the Validation Report at the end of the certificate. All figures stated in the certificate are valid at the frequency indicated.
- *Antenna Parameters with TSL:* The dipole is mounted with the spacer to position its feed point exactly below the center marking of the flat phantom section, with the arms oriented parallel to the body axis.
- *Feed Point Impedance and Return Loss:* These parameters are measured with the dipole positioned under the liquid filled phantom. The impedance stated is transformed from the measurement at the SMA connector to the feed point. The Return Loss ensures low reflected power. No uncertainty required.
- *Electrical Delay:* One-way delay between the SMA connector and the antenna feed point. No uncertainty required.
- *SAR measured:* SAR measured at the stated antenna input power.
- *SAR normalized:* SAR as measured, normalized to an input power of 1 W at the antenna connector.
- *SAR for nominal TSL parameters:* The measured TSL parameters are used to calculate the nominal SAR result..

Measurement Conditions

DASY system configuration, as far as not given on page 1.

DASY Version	DASY4	V4.7
Extrapolation	Advanced Extrapolation	
Phantom	Modular Flat Phantom V4.9	
Distance Dipole Center - TSL	15 mm	with Spacer
Zoom Scan Resolution	dx, dy, dz = 5 mm	
Frequency	835 MHz \pm 1 MHz	

Head TSL parameters

The following parameters and calculations were applied.

	Temperature	Permittivity	Conductivity
Nominal Head TSL parameters	22.0 °C	41.5	0.90 mho/m
Measured Head TSL parameters	(22.0 \pm 0.2) °C	41.1 \pm 6 %	0.91 mho/m \pm 6 %
Head TSL temperature during test	(21.5 \pm 0.2) °C	---	---

SAR result with Head TSL

SAR averaged over 1 cm ³ (1 g) of Head TSL	Condition	
SAR measured	250 mW input power	2.32 mW / g
SAR normalized	normalized to 1W	9.28 mW / g
SAR for nominal Head TSL parameters ¹	normalized to 1W	9.17 mW / g \pm 17.0 % (k=2)

SAR averaged over 10 cm ³ (10 g) of Head TSL	condition	
SAR measured	250 mW input power	1.53 mW / g
SAR normalized	normalized to 1W	6.12 mW / g
SAR for nominal Head TSL parameters ¹	normalized to 1W	6.07 mW / g \pm 16.5 % (k=2)

¹ Correction to nominal TSL parameters according to d), chapter "SAR Sensitivities"

Appendix**Antenna Parameters with Head TSL**

Impedance, transformed to feed point	50.4 Ω - 7.6 $j\Omega$
Return Loss	-22.4 dB

General Antenna Parameters and Design

Electrical Delay (one direction)	1.377 ns
----------------------------------	----------

After long term use with 100W radiated power, only a slight warming of the dipole near the feedpoint can be measured.

The dipole is made of standard semirigid coaxial cable. The center conductor of the feeding line is directly connected to the second arm of the dipole. The antenna is therefore short-circuited for DC-signals.

No excessive force must be applied to the dipole arms, because they might bend or the soldered connections near the feedpoint may be damaged.

Additional EUT Data

Manufactured by	SPEAG
Manufactured on	March 09, 2001

DASY4 Validation Report for Head TSL

Date/Time: 19.05.2008 12:17:50

Test Laboratory: SPEAG, Zurich, Switzerland

DUT: Dipole 835 MHz; Type: D835V2; Serial: D835V2 - SN:441

Communication System: CW-835; Frequency: 835 MHz; Duty Cycle: 1:1

Medium: HSL 900 MHz;

Medium parameters used: $f = 835$ MHz; $\sigma = 0.909$ mho/m; $\epsilon_r = 41.9$; $\rho = 1000$ kg/m³

Phantom section: Flat Section

Measurement Standard: DASY4 (High Precision Assessment)

DASY4 Configuration:

- Probe: ES3DV2 - SN3025; ConvF(5.97, 5.97, 5.97); Calibrated: 28.04.2008
- Sensor-Surface: 3.4mm (Mechanical Surface Detection)
- Electronics: DAE4 Sn601; Calibrated: 14.03.2008
- Phantom: Flat Phantom 4.9L; Type: QD000P49AA; ;
- Measurement SW: DASY4, V4.7 Build 71; Postprocessing SW: SEMCAD, V1.8 Build 184

Pin=250mW; dip=15mm; dist=3.4mm/Zoom Scan (7x7x7)/Cube 0:

Measurement grid: dx=5mm, dy=5mm, dz=5mm

Reference Value = 55.1 V/m; Power Drift = -0.008 dB

Peak SAR (extrapolated) = 3.38 W/kg

SAR(1 g) = 2.32 mW/g; SAR(10 g) = 1.53 mW/g

Maximum value of SAR (measured) = 2.62 mW/g

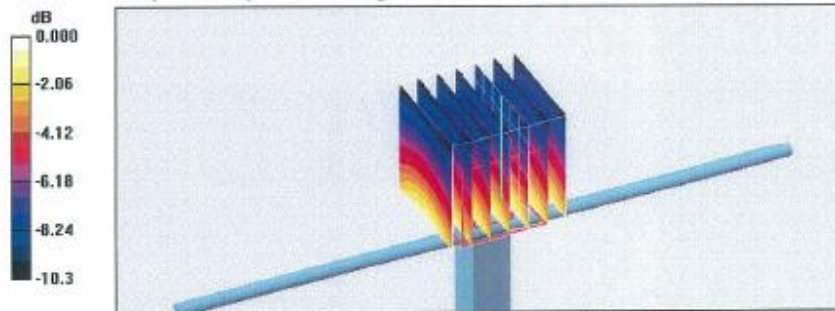

Impedance Measurement Plot for Head TSL

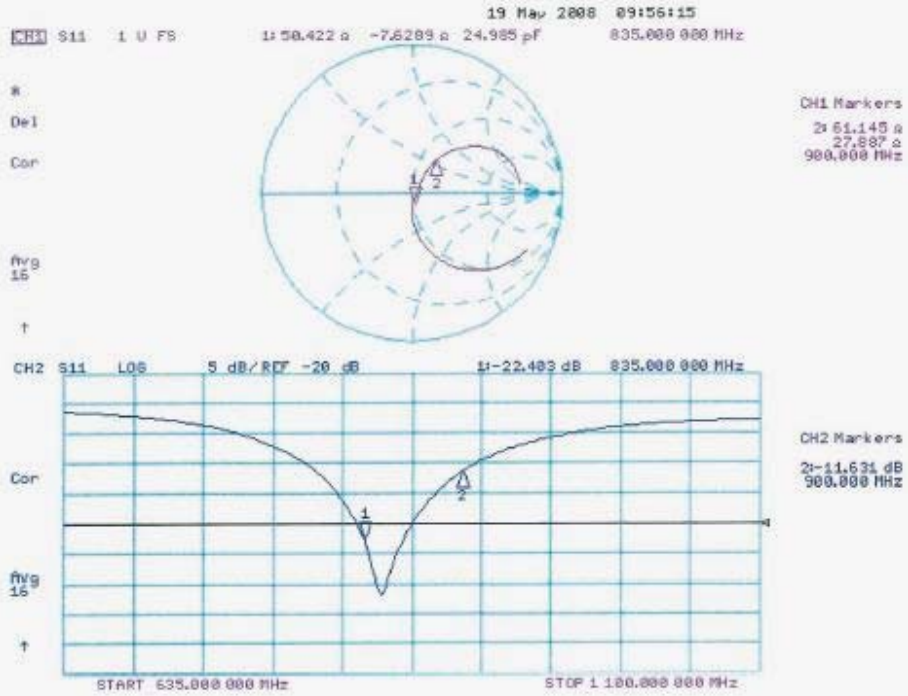

**Calibration Laboratory of
Schmid & Partner
Engineering AG**
Zeughausstrasse 43, 8004 Zurich, Switzerland



S Schweizerischer Kalibrierdienst
C Service suisse d'étalonnage
S Servizio svizzero di taratura
S Swiss Calibration Service

Accredited by the Swiss Federal Office of Metrology and Accreditation
The Swiss Accreditation Service is one of the signatories to the EA
Multilateral Agreement for the recognition of calibration certificates

Accreditation No.: **SCS 108**

Client **SGS KES (Dymstec)**

Certificate No: **D2450V2-734_Aug07**

CALIBRATION CERTIFICATE

Object **D2450V2 - SN: 734**

Calibration procedure(s) **QA CAL-05.v6
Calibration procedure for dipole validation kits**

Calibration date: **August 20, 2007**

Condition of the calibrated item **In Tolerance**

This calibration certificate documents the traceability to national standards, which realize the physical units of measurements (SI).
The measurements and the uncertainties with confidence probability are given on the following pages and are part of the certificate.

All calibrations have been conducted in the closed laboratory facility: environment temperature (22 ± 3)°C and humidity < 70%.

Calibration Equipment used (M&TE critical for calibration)

Primary Standards	ID #	Cal Date (Calibrated by, Certificate No.)	Scheduled Calibration
Power meter EPM-442A	GB37480704	03-Oct-06 (METAS, No. 217-00608)	Oct-07
Power sensor HP 8481A	US37292783	03-Oct-06 (METAS, No. 217-00608)	Oct-07
Reference 20 dB Attenuator	SN: 5086 (20g)	07-Aug-07 (METAS, No 217-00718)	Aug-08
Reference 10 dB Attenuator	SN: 5047.2 (10r)	07-Aug-07 (METAS, No 217-00718)	Aug-08
Reference Probe ES3DV3	SN 3025	19-Oct-06 (SPEAG, No. ES3-3025_Oct06)	Oct-07
DAE4	SN 801	30-Jan-07 (SPEAG, No. DAE4-801_Jan07)	Jan-08
Secondary Standards	ID #	Check Date (in house)	Scheduled Check
Power sensor HP 8481A	MY41092317	18-Oct-02 (SPEAG, in house check Oct-05)	In house check: Oct-07
RF generator Agilent E4421B	MY41000875	11-May-05 (SPEAG, in house check Nov-05)	In house check: Nov-07
Network Analyzer HP 8753E	US37390585 94206	18-Oct-01 (SPEAG, in house check Oct-06)	In house check: Oct-07

Calibrated by: **Name** Mike Meili **Function** Laboratory Technician **Signature** *M. Meili*

Approved by: **Name** Katja Pokovic **Function** Technical Manager **Signature** *Katja Pokovic*

Issued: August 21, 2007

This calibration certificate shall not be reproduced except in full without written approval of the laboratory.

**Calibration Laboratory of
Schmid & Partner
Engineering AG**
Zeughausstrasse 43, 8004 Zurich, Switzerland



S Schweizerischer Kalibrierdienst
C Service suisse d'étalonnage
S Servizio svizzero di taratura
S Swiss Calibration Service

Accredited by the Swiss Federal Office of Metrology and Accreditation
The Swiss Accreditation Service is one of the signatories to the EA
Multilateral Agreement for the recognition of calibration certificates

Accreditation No.: **SCS 108**

Glossary:

TSL	tissue simulating liquid
ConvF	sensitivity in TSL / NORM x,y,z
N/A	not applicable or not measured

Calibration is Performed According to the Following Standards:

- IEEE Std 1528-2003, "IEEE Recommended Practice for Determining the Peak Spatial-Averaged Specific Absorption Rate (SAR) in the Human Head from Wireless Communications Devices: Measurement Techniques", December 2003
- IEC 62209-1, "Procedure to measure the Specific Absorption Rate (SAR) for hand-held devices used in close proximity to the ear (frequency range of 300 MHz to 3 GHz)", February 2005
- Federal Communications Commission Office of Engineering & Technology (FCC OET), "Evaluating Compliance with FCC Guidelines for Human Exposure to Radiofrequency Electromagnetic Fields; Additional Information for Evaluating Compliance of Mobile and Portable Devices with FCC Limits for Human Exposure to Radiofrequency Emissions", Supplement C (Edition 01-01) to Bulletin 65

Additional Documentation:

- DASY4 System Handbook

Methods Applied and Interpretation of Parameters:

- Measurement Conditions:** Further details are available from the Validation Report at the end of the certificate. All figures stated in the certificate are valid at the frequency indicated.
- Antenna Parameters with TSL:** The dipole is mounted with the spacer to position its feed point exactly below the center marking of the flat phantom section, with the arms oriented parallel to the body axis.
- Feed Point Impedance and Return Loss:** These parameters are measured with the dipole positioned under the liquid filled phantom. The impedance stated is transformed from the measurement at the SMA connector to the feed point. The Return Loss ensures low reflected power. No uncertainty required.
- Electrical Delay:** One-way delay between the SMA connector and the antenna feed point. No uncertainty required.
- SAR measured:** SAR measured at the stated antenna input power.
- SAR normalized:** SAR as measured, normalized to an input power of 1 W at the antenna connector.
- SAR for nominal TSL parameters:** The measured TSL parameters are used to calculate the nominal SAR result.

Measurement Conditions

DASY system configuration, as far as not given on page 1.

DASY Version	DASY4	V4.7
Extrapolation	Advanced Extrapolation	
Phantom	Modular Flat Phantom V5.0	
Distance Dipole Center - TSL	10 mm	with Spacer
Zoom Scan Resolution	dx, dy, dz = 5 mm	
Frequency	2450 MHz ± 1 MHz	

Head TSL parameters

The following parameters and calculations were applied.

	Temperature	Permittivity	Conductivity
Nominal Head TSL parameters	22.0 °C	39.2	1.80 mho/m
Measured Head TSL parameters	(22.0 ± 0.2) °C	38.7 ± 6 %	1.81 mho/m ± 6 %
Head TSL temperature during test	(22.0 ± 0.2) °C	—	—

SAR result with Head TSL

SAR averaged over 1 cm ³ (1 g) of Head TSL	condition	
SAR measured	250 mW input power	13.3 mW / g
SAR normalized	normalized to 1W	53.2 mW / g
SAR for nominal Head TSL parameters ¹	normalized to 1W	52.8 mW / g ± 17.0 % (k=2)

SAR averaged over 10 cm ³ (10 g) of Head TSL	condition	
SAR measured	250 mW input power	6.16 mW / g
SAR normalized	normalized to 1W	24.6 mW / g
SAR for nominal Head TSL parameters ¹	normalized to 1W	24.5 mW / g ± 16.5 % (k=2)

¹ Correction to nominal TSL parameters according to d), chapter "SAR Sensitivities"

Appendix**Antenna Parameters with Head TSL**

Impedance, transformed to feed point	52.3 Ω + 4.7 j Ω
Return Loss	- 25.9 dB

General Antenna Parameters and Design

Electrical Delay (one direction)	1.153 ns
----------------------------------	----------

After long term use with 100W radiated power, only a slight warming of the dipole near the feedpoint can be measured.

The dipole is made of standard semirigid coaxial cable. The center conductor of the feeding line is directly connected to the second arm of the dipole. The antenna is therefore short-circuited for DC-signals.

No excessive force must be applied to the dipole arms, because they might bend or the soldered connections near the feedpoint may be damaged.

Additional EUT Data

Manufactured by	SPEAG
Manufactured on	May 07, 2003

DASY4 Validation Report for Head TSL

Date/Time: 20.08.2007 13:22:31

Test Laboratory: SPEAG, Zurich, Switzerland

DUT: Dipole 2450 MHz; Type: D2450V2; Serial: D2450V2 - SN734

Communication System: CW-2450; Frequency: 2450 MHz; Duty Cycle: 1:1

Medium: HSL U10 BB;

Medium parameters used: $f = 2450$ MHz; $\sigma = 1.81$ mho/m; $\epsilon_r = 38.7$; $\rho = 1000$ kg/m³

Phantom section: Flat Section

Measurement Standard: DASY4 (High Precision Assessment)

DASY4 Configuration:

- Probe: ES3DV2 - SN3025 (HF); CoefV(4.5, 4.5, 4.5); Calibrated: 19.10.2006
- Sensor-Surface: 4mm (Mechanical Surface Detection)
- Electronics: DAE4 Sa601; Calibrated: 30.01.2007
- Phantom: Flat Phantom 5.0 (front); Type: QD000P50AA
- Measurement SW: DASY4, V4.7 Build 53; Postprocessing SW: SEMCAD, V1.8 Build 172

Pin = 250 mW; d = 10 mm/Zoom Scan (7x7x7)/Cube 0:

Measurement grid: dx=5mm, dy=5mm, dz=5mm

Reference Value = 91.5 V/m; Power Drift = 0.037 dB

Peak SAR (extrapolated) = 27.8 W/kg

SAR(1 g) = 13.3 mW/g; SAR(10 g) = 6.16 mW/g

Maximum value of SAR (measured) = 14.6 mW/g

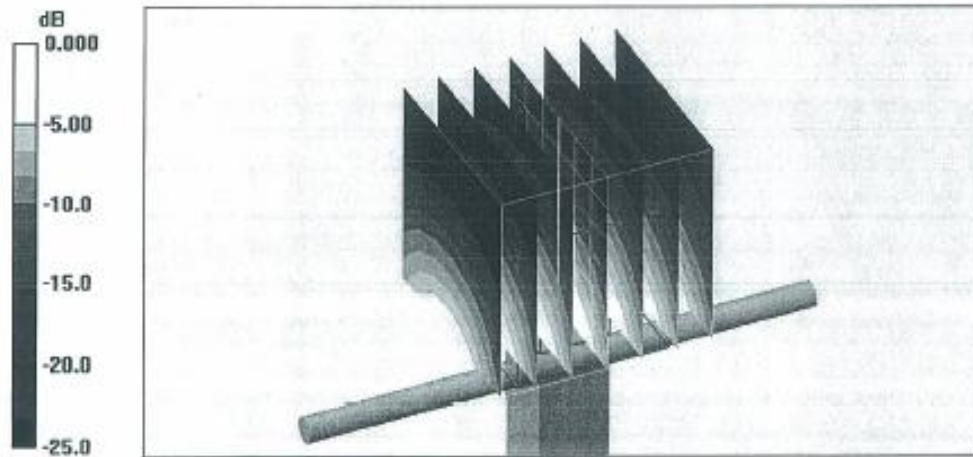

0 dB = 14.6mW/g

Impedance Measurement Plot for Head TSL

