

ATTACHMENT O – SAR TEST PLOTS

Test Laboratory: HCT

Company : AXESSTEL INC.
Mode : CDMA835 / Channel : 1013(EVDO)
Position : Body / Antenna : Intenna
Liquid Temperature : 21.6°C
Date Tested : February 2, 2007

DUT: MV140

Communication System: CDMA 835MHz FCC; Frequency: 824.7 MHz;Duty Cycle: 1:1
Medium parameters used: $f = 825 \text{ MHz}$; $\sigma = 0.977 \text{ mho/m}$; $\epsilon_r = 53.3$; $\rho = 1000 \text{ kg/m}^3$
Phantom section: Flat Section ;Measurement SW: DASY4, V4.7 Build 53

DASY4 Configuration:

- Probe: ET3DV6 - SN1798; ConvF(6.71, 6.71, 6.71); Calibrated: 2006-08-25
- Sensor-Surface: 4mm (Mechanical Surface Detection)
- Electronics: DAE4 Sn447; Calibrated: 2006-11-17
- Phantom: SAM 835/900 MHz; Type: SAM

EVDO BOTTOM 1013ch/Area Scan (51x81x1): Measurement grid: $dx=15\text{mm}$, $dy=15\text{mm}$
Maximum value of SAR (interpolated) = 1.02 mW/g

EVDO BOTTOM 1013ch/Zoom Scan (5x5x7)/Cube 0: Measurement grid: $dx=8\text{mm}$, $dy=8\text{mm}$,
 $dz=5\text{mm}$

Reference Value = 31.7 V/m; Power Drift = 0.196 dB
Peak SAR (extrapolated) = 1.29 W/kg
SAR(1 g) = 0.991 mW/g; SAR(10 g) = 0.717 mW/g
Maximum value of SAR (measured) = 1.06 mW/g

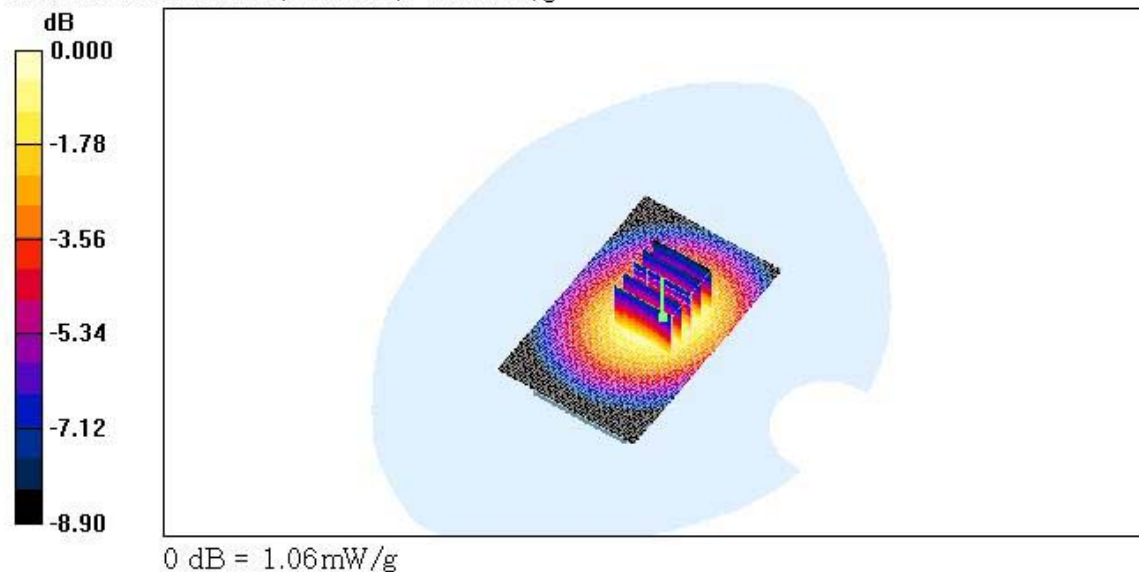

Test Laboratory: HCT

Company : AXESSTEL INC.
Mode : CDMA835 / Channel : 384(EVDO)
Position : Body / Antenna : Intenna
Liquid Temperature : 21.6°C
Date Tested : February 2, 2007

DUT: MV140

Communication System: CDMA 835MHz FCC; Frequency: 836.52 MHz; Duty Cycle: 1:1
Medium parameters used (interpolated): $f = 836.52$ MHz; $\sigma = 0.99$ mho/m; $\epsilon_r = 53.2$; $\rho = 1000$ kg/m³
Phantom section: Flat Section ; Measurement SW: DASY4, V4.7 Build 53

DASY4 Configuration:

- Probe: ET3DV6 - SN1798; ConvF(6.71, 6.71, 6.71); Calibrated: 2006-08-25
- Sensor-Surface: 4mm (Mechanical Surface Detection)
- Electronics: DAE4 Sn447; Calibrated: 2006-11-17
- Phantom: SAM 835/900 MHz; Type: SAM

EVDO BOTTOM 384ch/Area Scan (51x81x1): Measurement grid: $\Delta x = 15$ mm, $\Delta y = 15$ mm

Info: Interpolated medium parameters used for SAR evaluation.
Maximum value of SAR (interpolated) = 0.976 mW/g

EVDO BOTTOM 384ch/Zoom Scan (5x5x7)/Cube 0: Measurement grid: $\Delta x = 8$ mm, $\Delta y = 8$ mm, $\Delta z = 5$ mm

Reference Value = 31.7 V/m; Power Drift = -0.035 dB
Peak SAR (extrapolated) = 1.28 W/kg

SAR(1 g) = 0.948 mW/g; SAR(10 g) = 0.679 mW/g

Info: Interpolated medium parameters used for SAR evaluation.
Maximum value of SAR (measured) = 1.01 mW/g

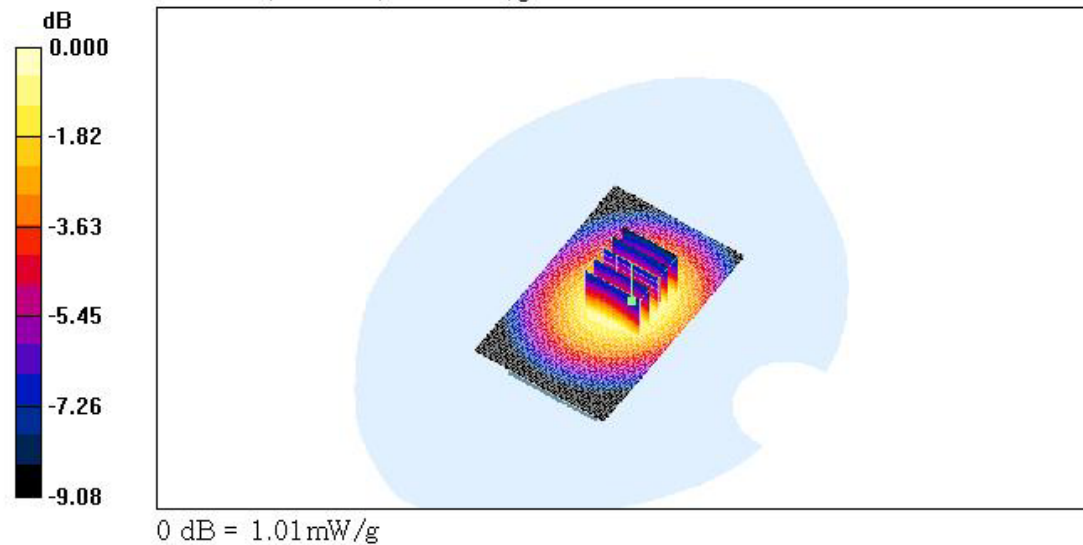

Test Laboratory: HCT

Company : AXESSTEL INC.
Mode : CDMA835 / Channel : 777 (EVDO)
Position : Body / Antenna : Intenna
Liquid Temperature : 21.6°C
Date Tested : February 2, 2007

DUT: MVI40

Communication System: CDMA 835MHz FCC; Frequency: 848.31 MHz; Duty Cycle: 1:1
Medium parameters used (interpolated): $f = 848.31$ MHz; $\sigma = 1$ mho/m; $\epsilon_r = 53.2$; $\rho = 1000$ kg/m³
Phantom section: Flat Section ; Measurement SW: DASY4, V4.7 Build 53

DASY4 Configuration:

- Probe: ET3DV6 - SN1798; ConvF(6.71, 6.71, 6.71); Calibrated: 2006-08-25
- Sensor-Surface: 4mm (Mechanical Surface Detection)
- Electronics: DAE4 Sn447; Calibrated: 2006-11-17
- Phantom: SAM 835/900 MHz; Type: SAM

EVDO BOTTOM 777ch/Area Scan (51x81x1): Measurement grid: dx=15mm, dy=15mm

Info: Interpolated medium parameters used for SAR evaluation.
Maximum value of SAR (interpolated) = 1.04 mW/g

EVDO BOTTOM 777ch/Zoom Scan (5x5x7)/Cube 0: Measurement grid: dx=8mm, dy=8mm, dz=5mm

Reference Value = 32.5 V/m; Power Drift = -0.065 dB

Peak SAR (extrapolated) = 1.31 W/kg

SAR(1 g) = 0.997 mW/g; SAR(10 g) = 0.714 mW/g

Info: Interpolated medium parameters used for SAR evaluation.

Maximum value of SAR (measured) = 1.06 mW/g

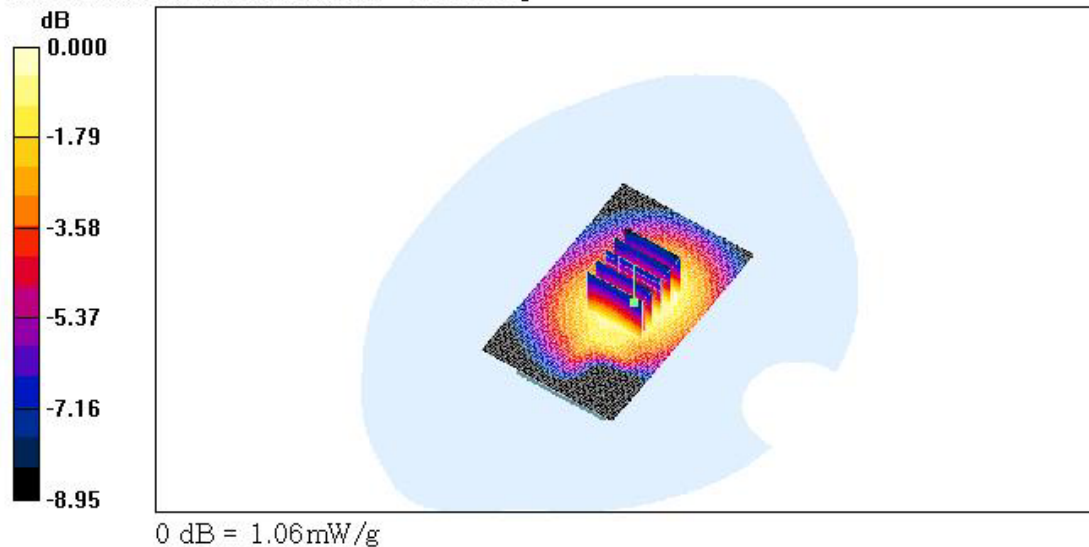

Test Laboratory: HCT

Company : AXESSTEL INC.
Mode : CDMA835 / Channel : 777 (EVDO)
Position : Body / Antenna : Intenna
Liquid Temperature : 21.6 °C
Date Tested : February 2, 2007

DUT: MV140

Communication System: CDMA 835MHz FCC; Frequency: 848.31 MHz; Duty Cycle: 1:1
Medium parameters used (interpolated): $f = 848.31$ MHz; $\sigma = 1$ mho/m; $\epsilon_r = 53.2$; $\rho = 1000$ kg/m³
Phantom section: Flat Section, Measurement SW: DASY4, V4.7 Build 53

DASY4 Configuration:

- Probe: ET3DV6 - SN1798; ConvF(6.71, 6.71, 6.71); Calibrated: 2006-08-25
- Sensor-Surface: 4mm (Mechanical Surface Detection)
- Electronics: DAE4 Sn447; Calibrated: 2006-11-17
- Phantom: SAM 835/900 MHz; Type: SAM

EDVO TOP 777 ch/Area Scan (51x81x1): Measurement grid: $dx=15$ mm, $dy=15$ mm

Info: Interpolated medium parameters used for SAR evaluation.
Maximum value of SAR (interpolated) = 0.983 mW/g

EDVO TOP 777 ch/Zoom Scan (5x5x7)/Cube 0: Measurement grid: $dx=8$ mm, $dy=8$ mm, $dz=5$ mm
Reference Value = 30.2 V/m; Power Drift = 0.195 dB
Peak SAR (extrapolated) = 1.28 W/kg
SAR(1 g) = 0.940 mW/g; SAR(10 g) = 0.678 mW/g

Info: Interpolated medium parameters used for SAR evaluation.
Maximum value of SAR (measured) = 0.999 mW/g

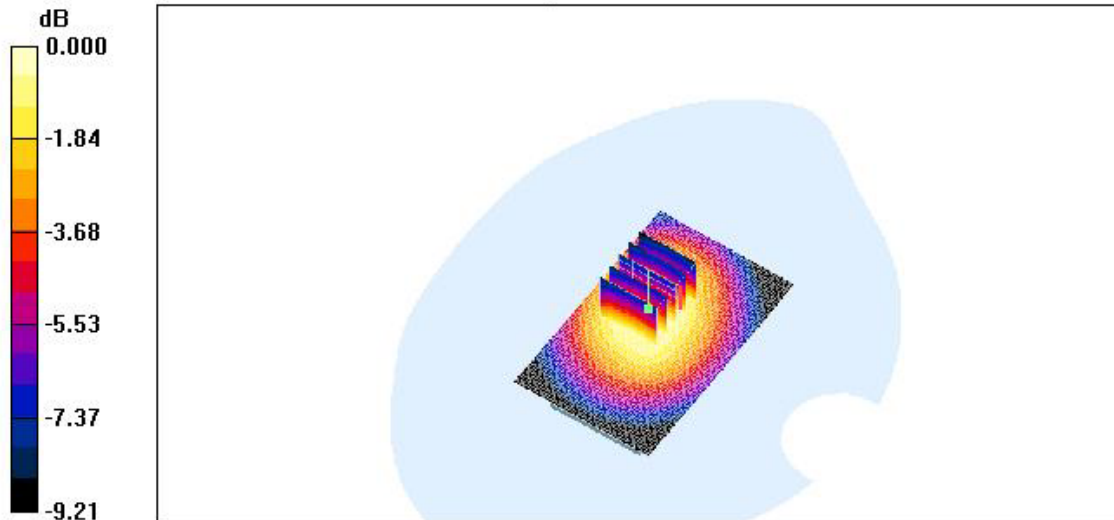

0 dB = 0.999mW/g

Test Laboratory: HCT

Company : AXESSTEL INC.
Mode : CDMA835 / Channel : 777
Position : Body / Antenna : Intenna
Liquid Temperature : 21.6°C
Date Tested : February 2, 2007

DUT: MV140

Communication System: CDMA 835MHz FCC; Frequency: 848.31 MHz; Duty Cycle: 1:1
Medium parameters used (interpolated): $f = 848.31$ MHz; $\sigma = 1$ mho/m; $\epsilon_r = 53.2$; $\rho = 1000$ kg/m³
Phantom section: Flat Section ; Measurement SW: DASY4, V4.7 Build 53

DASY4 Configuration:

- Probe: ET3DV6 - SN1798; ConvF(6.71, 6.71, 6.71); Calibrated: 2006-08-25
- Sensor-Surface: 4mm (Mechanical Surface Detection)
- Electronics: DAE4 Sn447; Calibrated: 2006-11-17
- Phantom: SAM 835/900 MHz; Type: SAM

CDMA BOTTOM 777ch/Area Scan (51x81x1): Measurement grid: $dx=15$ mm, $dy=15$ mm

Info: Interpolated medium parameters used for SAR evaluation.
Maximum value of SAR (interpolated) = 0.543 mW/g

CDMA BOTTOM 777ch/Zoom Scan (5x5x7)/Cube 0: Measurement grid: $dx=8$ mm, $dy=8$ mm, $dz=5$ mm
Reference Value = 22.5 V/m; Power Drift = -0.024 dB
Peak SAR (extrapolated) = 0.718 W/kg
SAR(1 g) = 0.549 mW/g; SAR(10 g) = 0.394 mW/g

Info: Interpolated medium parameters used for SAR evaluation.
Maximum value of SAR (measured) = 0.581 mW/g

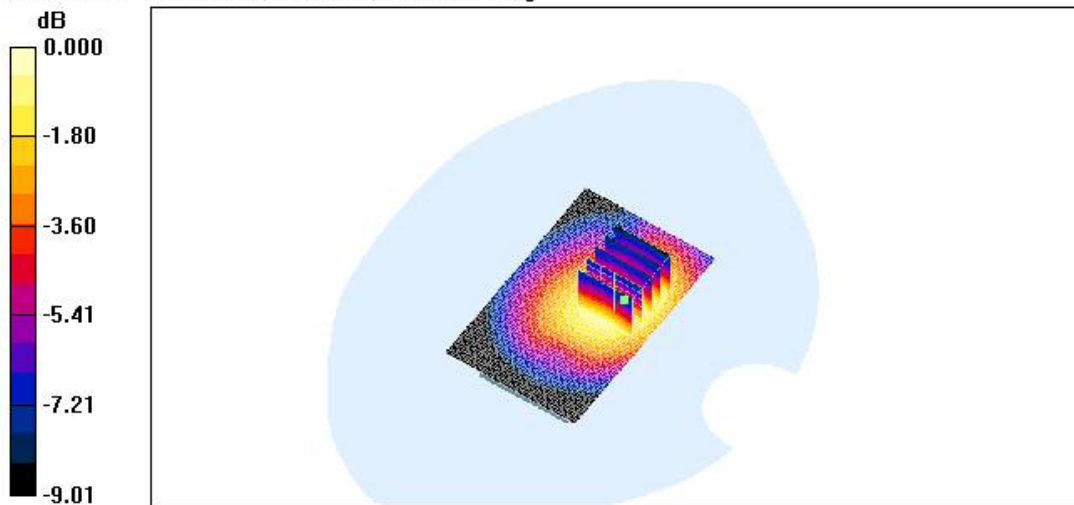

0 dB = 0.581mW/g

Test Laboratory: HCT

Company : AXESSTEL INC.
Mode : CDMA835 / Channel : 777 (EVDO)
Position : Body / Antenna : Intenna
Liquid Temperature : 21.6 °C
Date Tested : February 2, 2007

DUT: MV140

Communication System: CDMA 835MHz FCC; Frequency: 848.31 MHz; Duty Cycle: 1:1
Medium parameters used (interpolated): $f = 848.31$ MHz; $\sigma = 1$ mho/m; $\epsilon_r = 53.2$; $\rho = 1000$ kg/m³
Phantom section: Flat Section ; Measurement SW: DASY4, V4.7 Build 53

DASY4 Configuration:

- Probe: ET3DV6 - SN1798; ConvF(6.71, 6.71, 6.71); Calibrated: 2006-08-25
- Sensor-Surface: 0mm (Fix Surface)
- Electronics: DAE4 Sn447; Calibrated: 2006-11-17
- Phantom: SAM 835/900 MHz; Type: SAM

EVDO BOTTOM 777ch/Z Scan (1x1x31): Measurement grid: dx=20mm, dy=20mm, dz=5mm

Info: Interpolated medium parameters used for SAR evaluation.
Maximum value of SAR (measured) = 1.02 mW/g

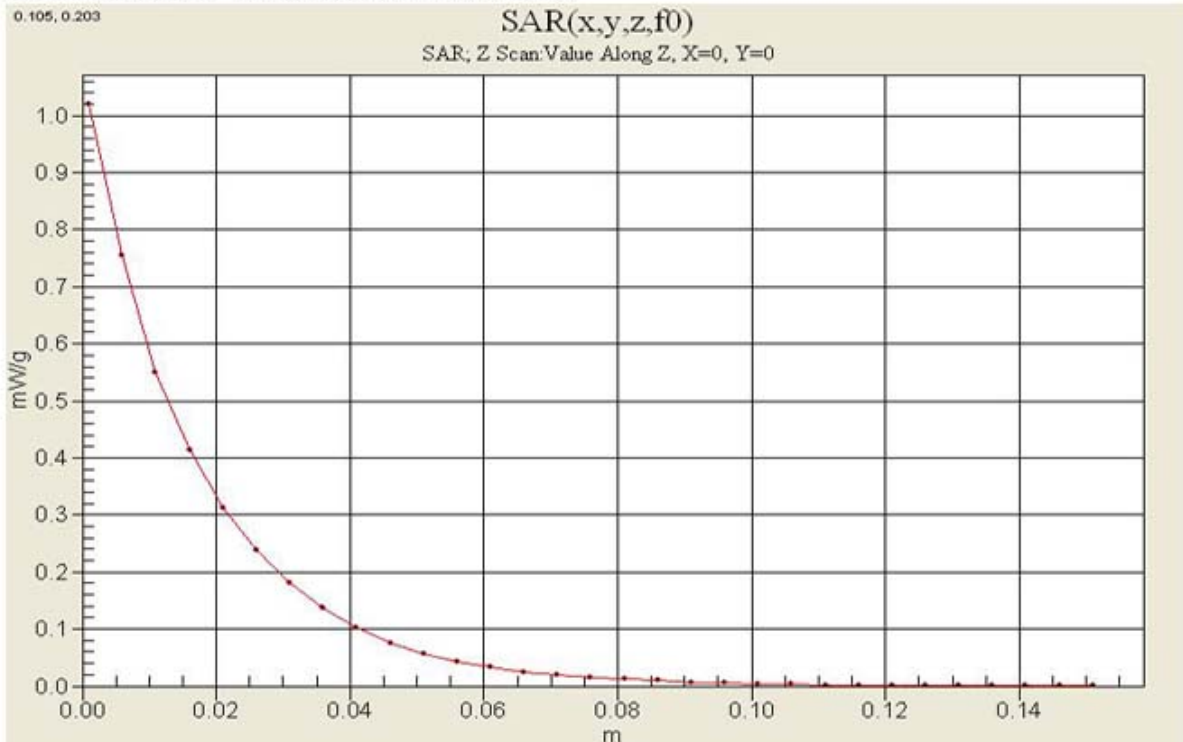

Test Laboratory: HCT

Company : AXESSTEL INC.
Mode : CDMA835 / Channel : 777
Position : Body / Antenna : Intenna
Liquid Temperature : 22.1 °C
Date Tested : April 30, 2007

DUT: MV140

Communication System: CDMA 835MHz FCC; Frequency: 848.31 MHz; Duty Cycle: 1:1
Medium parameters used (interpolated): $f = 848.31$ MHz; $\sigma = 0.994$ mho/m; $\epsilon_r = 54.7$; $\rho = 1000$ kg/m³

Phantom section: Flat Section ; Measurement SW: DASY4, V4.7 Build 53

DASY4 Configuration:

- Probe: ET3DV6 - SN1607; ConvF(6.58, 6.58, 6.58); Calibrated: 2007-02-21
- Sensor-Surface: 4mm (Mechanical Surface Detection)
- Electronics: DAE3 Sn446; Calibrated: 2006-11-15
- Phantom: SAM 835/900 MHz; Type: SAM

CDMA TOP 777ch/Area Scan (51x81x1): Measurement grid: dx=15mm, dy=15mm

Info: Interpolated medium parameters used for SAR evaluation.
Maximum value of SAR (interpolated) = 0.753 mW/g

CDMA TOP 777ch/Zoom Scan (5x5x7)/Cube 0: Measurement grid: dx=8mm, dy=8mm, dz=5mm
Reference Value = 27.8 V/m; Power Drift = 0.058 dB
Peak SAR (extrapolated) = 0.991 W/kg
SAR(1 g) = 0.743 mW/g; SAR(10 g) = 0.531 mW/g

Info: Interpolated medium parameters used for SAR evaluation.
Maximum value of SAR (measured) = 0.796 mW/g

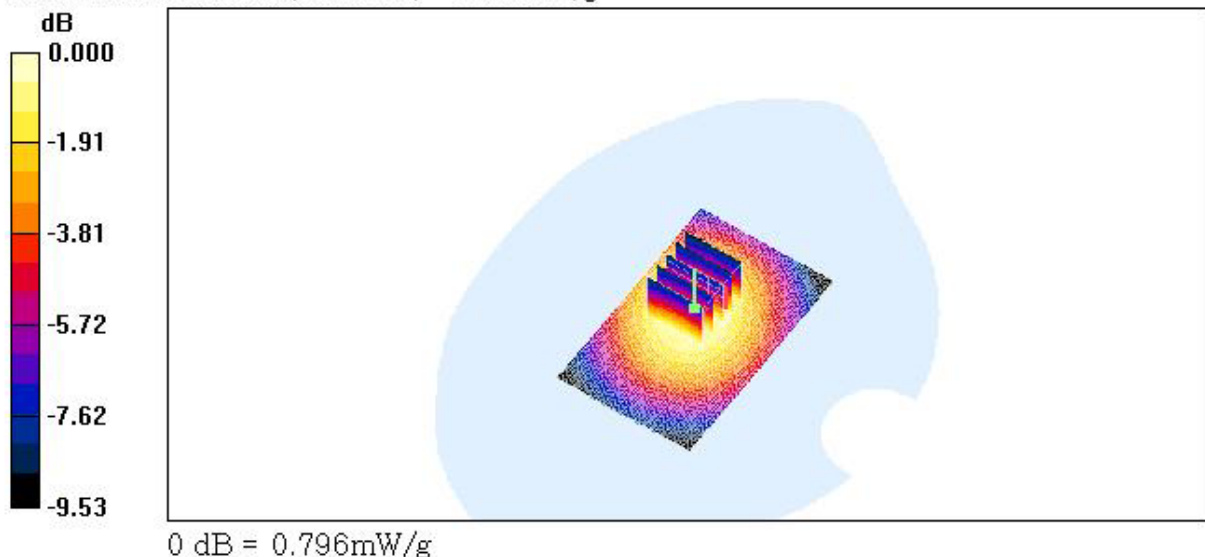

Test Laboratory: HCT

Company : AXESSTEL INC.
Mode : CDMA835 / Channel : 777 (EVDO)
Position : Body / Antenna : Intenna
Liquid Temperature : 22.1 °C
Date Tested : April 30, 2007

DUT: MVI40

Communication System: CDMA 835MHz FCC; Frequency: 848.31 MHz; Duty Cycle: 1:1
Medium parameters used (interpolated): $f = 848.31$ MHz, $\sigma = 0.994$ mho/m, $\epsilon_r = 54.7$; $\rho = 1000$

kg/m³

Phantom section: Flat Section ; Measurement SW: DASY4, V4.7 Build 53

DASY4 Configuration:

- Probe: ET3DV6 - SN1607; ConvF(6.58, 6.58, 6.58); Calibrated: 2007-02-21
- Sensor-Surface: 4mm (Mechanical Surface Detection)
- Electronics: DAE3 Sn446; Calibrated: 2006-11-15
- Phantom: SAM 835/900 MHz; Type: SAM

EVDO Bottom 777ch/Area Scan (51x81x1): Measurement grid: dx=15mm, dy=15mm

Info: Interpolated medium parameters used for SAR evaluation.
Maximum value of SAR (interpolated) = 0.802 mW/g

EVDO Bottom 777ch/Zoom Scan (5x5x7)/Cube 0: Measurement grid: dx=8mm, dy=8mm, dz=5mm

Reference Value = 28.3 V/m; Power Drift = -0.072 dB
Peak SAR (extrapolated) = 1.05 W/kg

SAR(1 g) = 0.782 mW/g; SAR(10 g) = 0.561 mW/g

Info: Interpolated medium parameters used for SAR evaluation.
Maximum value of SAR (measured) = 0.824 mW/g

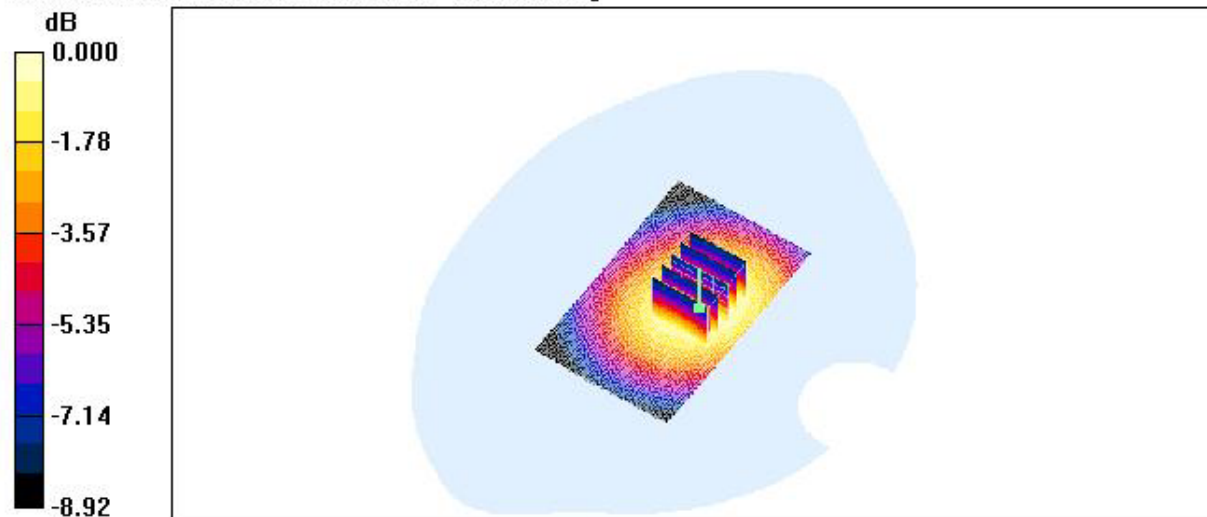

Test Laboratory: HCT

Company : AXESSTEL INC.
Mode : CDMAB35 / Channel : 777 (EVDO)
Position : Body / Antenna : Intenna
Liquid Temperature : 22.1 °C
Date Tested : April 30, 2007

DUT: MV140

Communication System: CDMA 835MHz FCC, Frequency: 848.31 MHz, Duty Cycle: 1:1
Medium parameters used (interpolated): $f = 848.31$ MHz; $\sigma = 0.994$ mho/m; $\epsilon_r = 54.7$; $\rho = 1000$

kg/m³

Phantom section: Flat Section ; Measurement SW: DASY4, V4.7 Build 53

DASY4 Configuration:

- Probe: ET3DV6 - SN1607; ConvF(6.58, 6.58, 6.58); Calibrated: 2007-02-21
- Sensor-Surface: 4mm (Mechanical Surface Detection)
- Electronics: DAE3 Sn446; Calibrated: 2006-11-15
- Phantom: SAM 835/900 MHz; Type: SAM

EVDO TOP 777ch/Area Scan (51x81x1): Measurement grid: $dx=15$ mm, $dy=15$ mm

Info: Interpolated medium parameters used for SAR evaluation.
Maximum value of SAR (interpolated) = 0.905 mW/g

EVDO TOP 777ch/Zoom Scan (5x5x7)/Cube 0: Measurement grid: $dx=8$ mm, $dy=8$ mm, $dz=5$ mm

Reference Value = 30.3 V/m; Power Drift = 0.009 dB

Peak SAR (extrapolated) = 1.14 W/kg

SAR(1 g) = 0.858 mW/g; SAR(10 g) = 0.610 mW/g

Info: Interpolated medium parameters used for SAR evaluation.
Maximum value of SAR (measured) = 0.912 mW/g

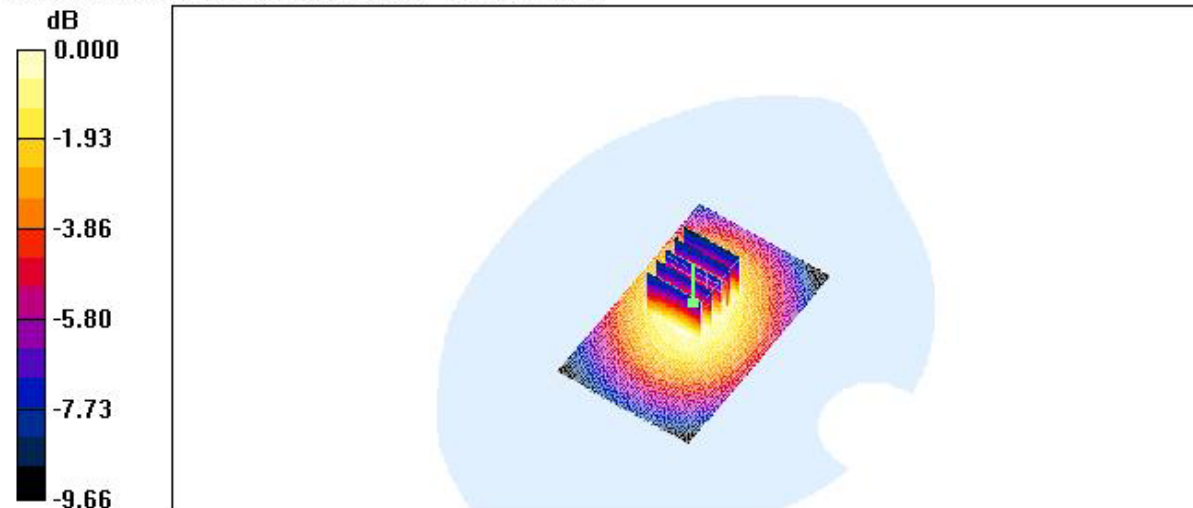

0 dB = 0.912mW/g