

HYUNDAI CALIBRATION & CERTIFICATION TECH. CO., LTD.



PRODUCT COMPLIANCE DIVISION
SAN 136-1, AMI-RI, BUBAL-EUP, ICHEON-SI, KYOUNGKI-DO, 467-701, KOREA
TEL : +82 31 639 8518 FAX : +82 31 639 8525 www.hctec.co.kr



CERTIFICATE OF COMPLIANCE

FCC Part 24 Certification

AXESSTEL INC
6305 LUSK BLVD
SAN DIEGO, CA 92121
U.S.A

Date of Issue : October 17, 2003
Test Report No.: HCT-SAR03-1004
Test Site: HYUNDAI CALIBRATION & CERTIFICATION
TECHNOLOGIES CO., LTD.
FRN: 0005-8642- 21

FCC ID : PH7AXWP1900
APPLICANT : AXESSTEL INC.

EUT Type: Fixed WLL Telephone (CDMA)
Tx Frequency: 1851.25 — 1908.75 MHz (PCS CDMA)
Rx Frequency: 1931.25 — 1988.75 MHz (PCS CDMA)
Max. RF Output Power: 0.357W ERP CDMA (25.531 dBm)
Trade Name/Model(s): AXESSTEL / AXW-P1900
FCC Classification: PCS Licensed Transmitter (PCB)
Application Type: Certification
FCC Rule Part(s): §24(H), §2
Maximum SAR: 0.542W/kg CDMA Body SAR
Antenna Specifications: Manufacturer: HANKOOK ANTENNA CO., LTD.
PN: TB4-1900T (Length= 171± 3.0mm)
Emission Designator(s): 1M27F9W

This equipment has been shown to be capable of compliance with the applicable technical standards as indicated in the measurement report and was tested in accordance with the measurement procedures specified in ?2.947.

I attest to the accuracy of data. All measurements reported herein were performed by me or were made under my supervision and are correct to the best of my knowledge and belief. I assume full responsibility for the completeness of these measurements and vouch for the qualifications of all personstaking them.

Hyundai C-Tech Co., Ltd. Certifies that no party to this application has been denied FCC benefits pursuant to section 5301 of the Anti- Drug Abuse Act of 1998, 21 U.S. C. 853(a)

Handwritten signature of Ki-Soo Kim

Report prepared by : Ki-Soo Kim
Manager of Product Compliance Team



This report only responds to the tested sample and may not be reproduced, except in full, without written approval of the HCT Co., Ltd.

Table of Contents

ATTACHMENT A: COVER LETTER(S)	
ATTACHMENT B: ATTESTATION STATEMENT(S)	
ATTACHMENT C: TEST REPORT	
1.1 SCOPE -----	3
2.1 INTRODUCTION -----	4
3.1 INSERTS PER §2.1033(d)-----	5
4.1 DESCRIPTION OF TESTS-----	6-15
5.1 EFFECTIVE RADIATED POWER OUTPUT -----	16
6.1 RADIATED MEASUREMENTS-----	17-19
7.1 FREQUENCY STABILITY -----	20
8.1 PLOTS OF EMISSIONS-----	21
9.1 LIST OF TEST EQUIPMENT -----	22
10.1 SAMPLE CALCULATIONS-----	23
11.1 CONCLUSION-----	24
ATTACHMENT D: TEST PLOTS	
ATTACHMENT E: FCC ID LABEL & LOCATION	
ATTACHMENT F: TEST SETUP PHOTOGRAPHS	
ATTACHMENT G: EXTERNAL PHOTOGRAPHS	
ATTACHMENT H: INTERNAL PHOTOGRAPHS	
ATTACHMENT I: BLOCK DIAGRAM (S)	
ATTACHMENT J: CIRCUIT DIAGRAMS & DESCRIPTION	
ATTACHMENT K: PARTS LIST	
ATTACHMENT L: OPERATIONAL DESCRIPTION	
ATTACHMENT M: USER'S MANUAL	
ATTACHMENT N: SAR MEASUREMENT REPORT	
ATTACHMENT O: SAR TEST DATA	
ATTACHMENT P: SAR TEST SETUP PHOTOGRAPHS	
ATTACHMENT Q: DIPOLE VALIDATION	
ATTACHMENT R: PROBE CALIBRATION	
ATTACHMENT S: DIPOLE CALIBRATION	
ATTACHMENT T: EMI MEASUREMENT REPORT	

MEASUREMENT REPORT

1.1 SCOPE

Measurement and determination of electromagnetic emissions (EME) of radio frequency devices including intentional and/or unintentional radiators for compliance with the technical rules and regulations of the Federal Communications Commission.

General Information

Company Name:	AXESSTEL INC.
Address:	6305 LUSK BLVD. SAN DIEGO, CA 92121, U.S.A
Attention:	Mr. David Kim
Tel. / Fax :	858- 625-2100 / 858- 625- 2110
E-Mail :	dskim@axesstel.com

- FCC ID: PH7AXWP1900
- Quantity: Quantity production is planned
- EUT Type: Fixed WLL Telephone (CDMA)
- Trade Name: AXESSTEL
- Model(s): AXW -P1900
- Serial Number(s): AXW20031000002
- Emission Designator(s): 1M27F9W
- Tx Frequency: 1851.25 — 1908.75 MHz (PCS CDMA)
- Rx Frequency: 1931.25 — 1988.75 MHz (PCS CDMA)
- Application Type: Certification
- FCC Classification: PCS Licensed Transmitter (PCB)
- FCC Rule Part(s): §24(H), §2
- Modulation(s): CDMA
- Antenna Type: Fixed
- Max RF. Output Power: 0.357W ERP CDMA (25.531 dBm)
- Date(s) of Tests: October 14, 2003 – October 15, 2003
- Place of Tests: Hyundai G-Tech. EMC Lab.
Icheon, Kyounki-Do, KOREA
- Report Serial No.: HCT-SAR03-1004

2.1 INTRODUCTION

EUT DESCRIPTION

The AXESSTEL INC. AXW-P1900 Fixed WLL Telephone (CDMA). Its basic purpose is used for communications. It transmits from CDMA(1851.25 — 1908.75)MHz and receives from CDMA(1931.25 — 1988.75)MHz. The RF power is rated at CDMA (0.357W)

MEASURING INSTRUMENT CALIBRATION

The measuring equipment, which was utilized in performing the tests documented herein, has been calibrated in accordance with the manufacturer's recommendations for utilizing calibration equipment, which is traceable to recognized national standards.

Test Facility

The open area test site and conducted measurement facility used to collect the radiated data are located at the 254 -1, Maekok-Ri, Hobup-Myun, Ichon-Si, Kyoungki-Do, 467 -701, KOREA. The site is constructed in conformance with the requirements of ANSI C63.4 and CISPR Publication 22. Detailed description of test facility was submitted to the Commission and accepted dated July 23, 2003(Confirmation Number: 90661)

3.1 INSERTS

Function of Active Devices (Confidential)

The Function of active devices are shown in Attachment K.

Block/Circuit Diagrams & Description (Confidential)

The circuit diagrams & description are shown in Attachment J, and the block diagrams are shown in Attachment I.

Operating Instructions

The instruction manual is shown in Attachment M.

Parts List & Tune-Up Procedure (Confidential)

The parts list & tune-up procedure are shown in Attachment L.

Description of Freq. Stabilization Circuit (Confidential)

The description of frequency stabilization circuit is shown in Attachment K.

Description for Suppression of Spurious Radiation, for Limiting Modulation, and Harmonic Suppression Circuits (Confidential)

The description of suppression stabilization circuits are shown in Attachment K

4.1 DESCRIPTION OF TESTS

4.1 RF Power output.

Test Set-up

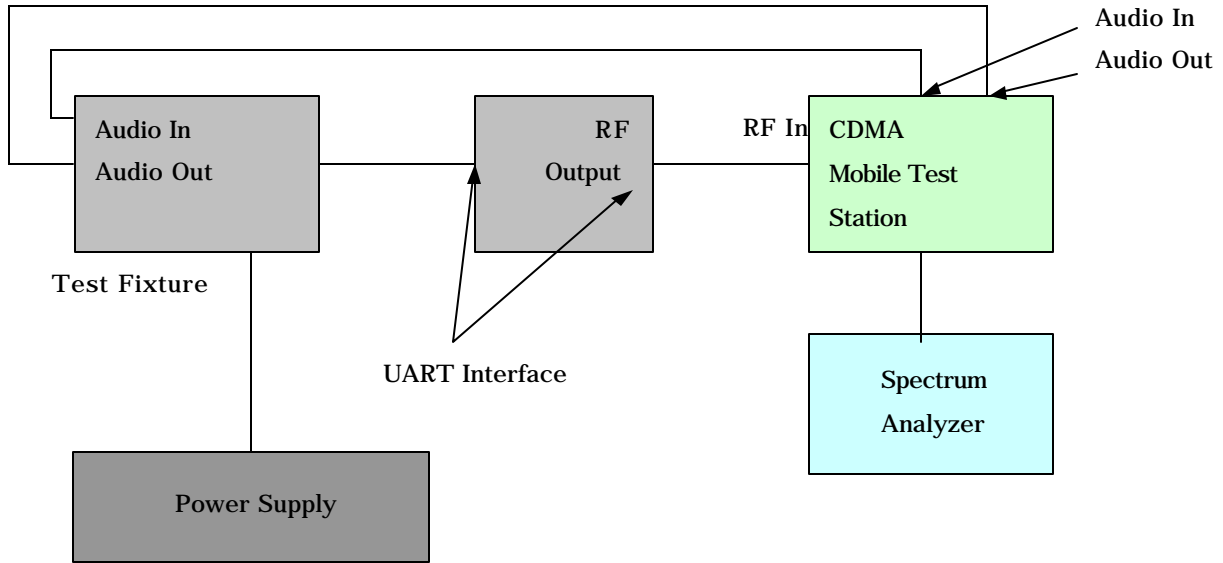

UART Interface: The UART Interface has a serial communication link and RF Interface port that can be used to test , debug or upgrade the phone's functions and characteristics.

EUT : Equipment Under Test

Test Procedure

The power is read at the spectrum analyzer through the duplex port of CDMA mobile test station.

RF power output is measured at the RF output terminal(UART Interface) on the bottom side of the EUT.

4.2 Effective Radiated Power.

Test Set-up

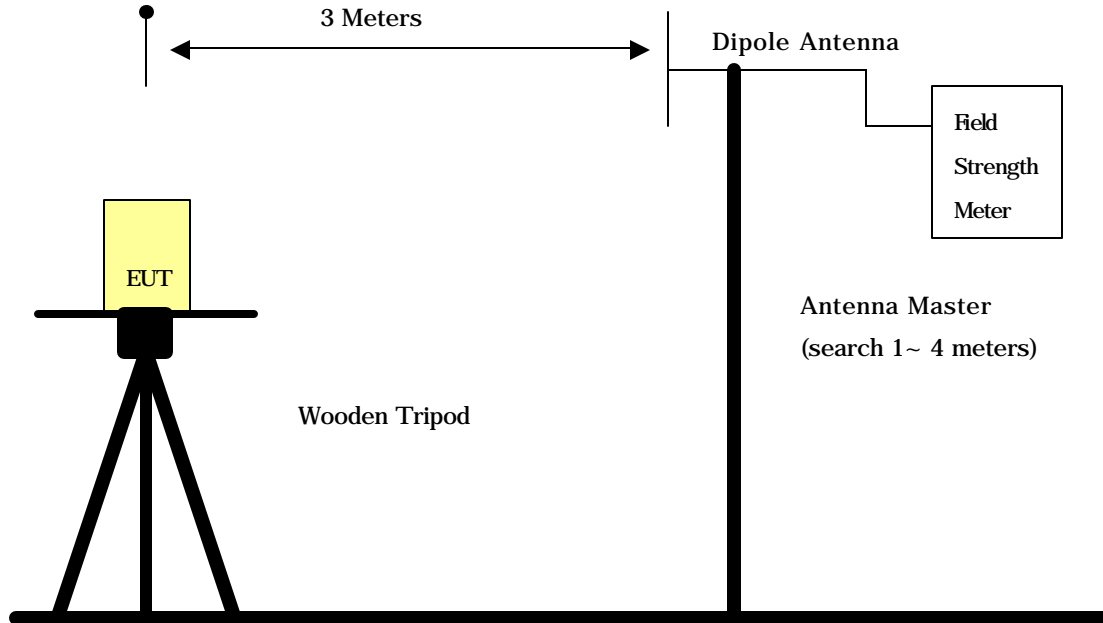

Open Field Test Site

Test Procedure

The measurement facilities used for this test have been documented in previous filings with the commission pursuant to section 2.948.

The open field test site is situated in open field with ground screen whose site attenuation characteristics meet ANSI C63.4 – 1992. A mast capable of lifting the receiving antenna from a height of one to four meters is used together with a rotatable wooden platform mounted at three from the antenna mast.

- 1) The EUT mounted on a wooden tripod is 0.8 meter above test site ground level.
- 2) During the test , the turn table is rotated and the antenna height is also varied from 1 to 4 meters until the maximum signal is found.
- 3) Record the field strength meter's level.
- 4) Replace the EUT with $\lambda/2$ dipole antenna that is connected to a calibrated signal generator.
- 5) Increase the signal generator output till the field strength meter's level is equal to the item(4).
- 6) The signal generator output level is the rating of effective radiated power(ERP).
- 7) The instrument settings used (RBW/ VBW) during ERP/ EIRP output power measurement are as Belows ;
 - Below 1GHz : RBW 3MHz, VBW 3 MHz
 - Above 1GHz : RBW 3MHz, VBW 3MHz

4.3 Modulation Requirements.

4.3.1 Frequency response of the audio modulation circuit.

Test Set-up

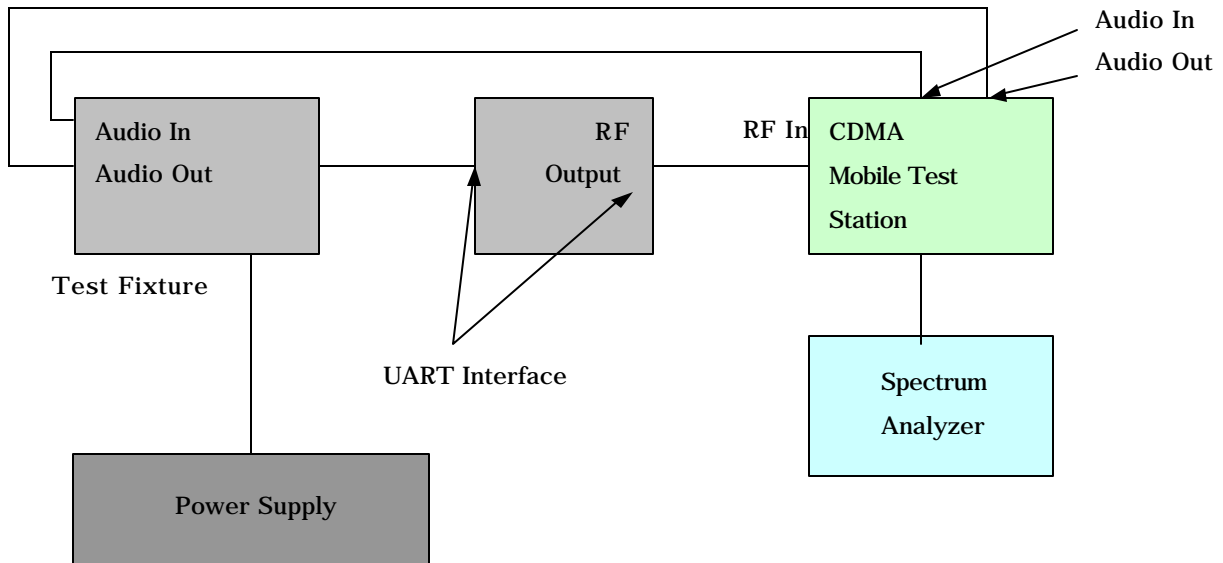

UART Interface: The UART Interface has a serial communication link that can be used to test , debug or upgrade the phone's functions and characteristics.

Test Procedure

- 1) Set the frequency deviation $\pm 2.9\text{KHz}$ at the audio tone by adjusting the audio generator and record the demod out level at 1KHz.
- 2) Change the frequency of audio generator from 300KHz to 3000Hz and record the demod out level relative to the level at 1KHz.
- 3) Adjust the audio input frequency to 1000KHz and adjust the input level to 20dB greater than that required to produce $\pm 8\text{KHz}$ deviation.
- 4) Change the frequency of audio generator from 3000Hz to 30,000Hz and record the demod out level relative to the level at 1KHz.

4.3.2 Modulation levels and response of modulation limiting circuitry.

Test Set-up

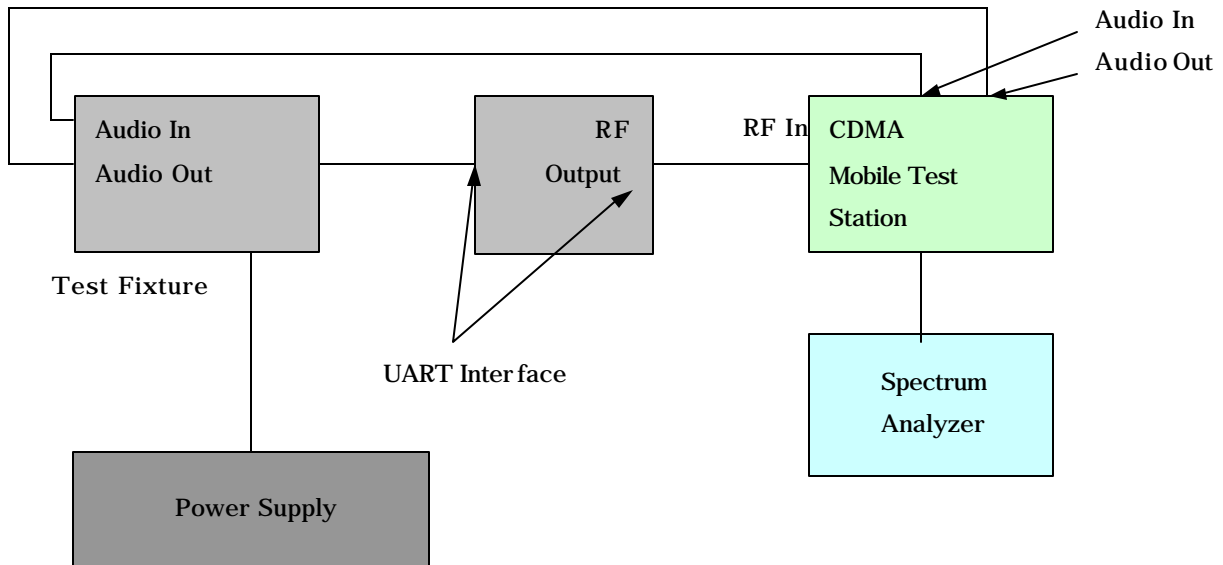

UART Interface: The UART Interface has a serial communication link that can be used to test , debug or upgrade the phone's functions and characteristics.

Test Procedure

- 1) Set the frequency deviation $\pm 7.2\text{KHz}$ at the audio tone by adjusting the audio generator. This level will be the 0 dB reference.
- 2) Increase the audio level from 0 dB reference to 30 dB in increments of 5 dB and record the frequency deviation.
- 3) This measurement is then repeated at 300Hz, 500Hz, 2000Hz and 3000Hz audio tone.

4.3.3 Levels of modulating signals.

Test Set-up

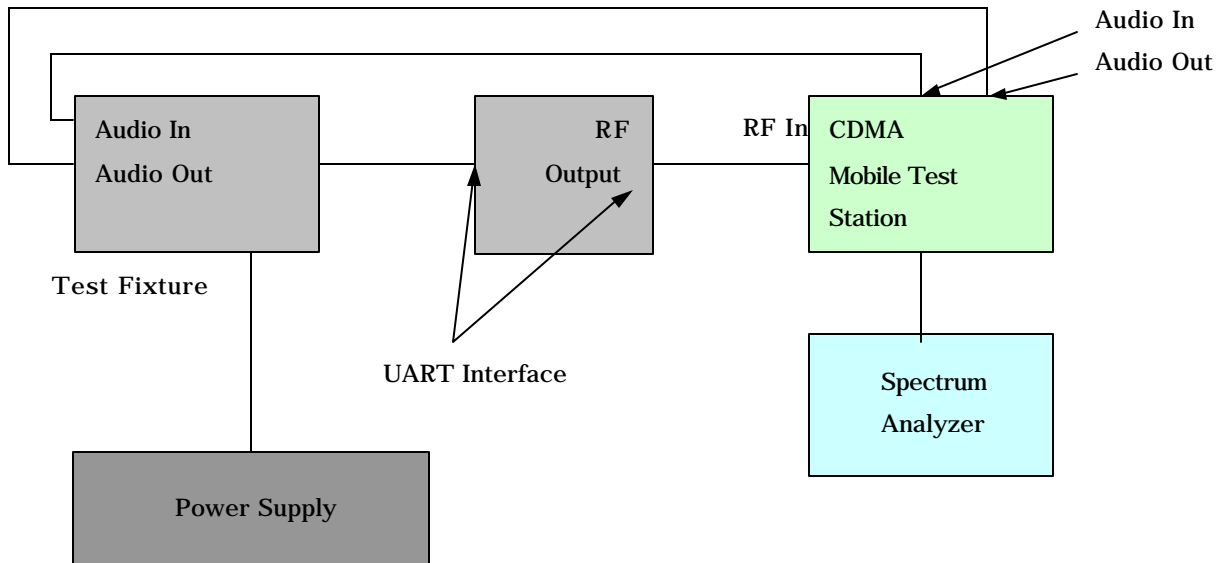

UART Interface: The UART Interface has a serial communication link that can be used to test , debug or upgrade the phone's functions and characteristics.

Test Procedure

- 1) Select the supervisory audio tone test mode pursuant to "Tune – up procedure" and record the frequency deviation on the modulation analyzer.
- 2) Select the signalling tone test mode pursuant to "Tune – up procedure" and record the frequency deviation on the modulation analyzer.
- 3) Select the TX data test mode pursuant to "Tune – up procedure" and record the frequency deviation on the modulation analyzer .

4.3.4 Occupied bandwidth.

Test Set-up

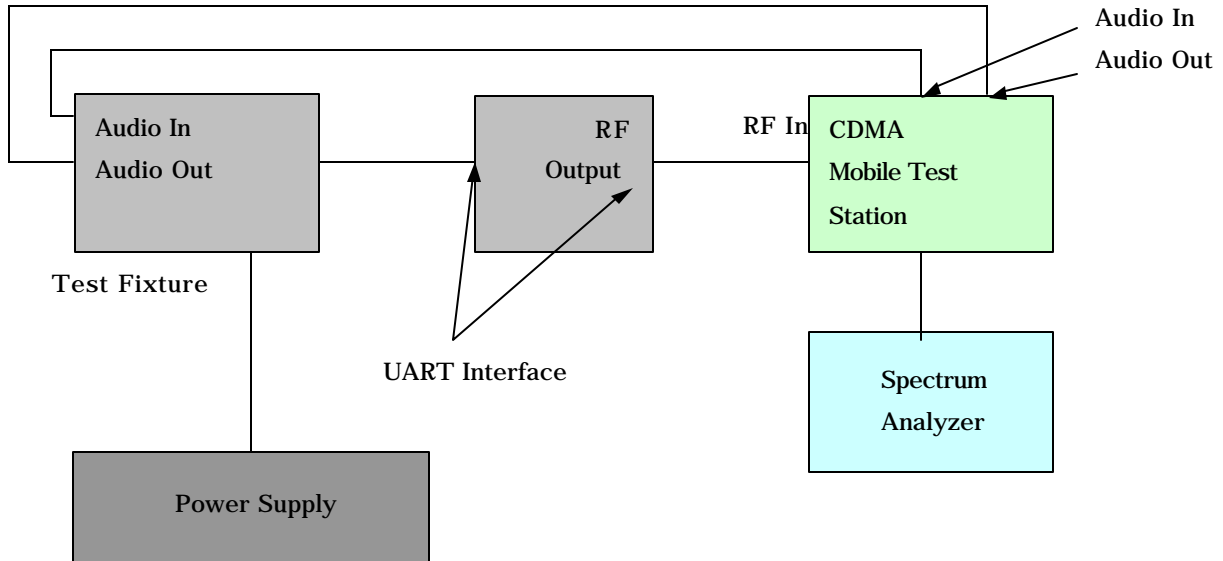

UART Interface: The UART Interface has a serial communication link that can be used to test , debug or upgrade the phone's functions and characteristics.

Test Procedure

1. F3E radiotelephony mode.
 - 1) The audio generator is set on the frequency of maximum audio response of the audio modulating circuit and its level adjusted for 50% modulation.
 - 2) Increase the audio level 16 dB greater than that necessary to produce 50 percent modulation and change the audio frequency to 2,500 Hz tone.
 - 3) The occupied bandwidth is drawn from the spectrum analyzer display.
2. F1D wideband data mode.
 - 1) Select the TX data test mode pursuant to "Tune-up procedure".
 - 2) The occupied bandwidth is drawn from the spectrum analyzer display.
3. F3D supervisory audio tone mode.
 - 1) Select the supervisory tone test mode pursuant to "Tune-up procedure".
 - 2) The occupied bandwidth is drawn from the spectrum analyzer display.
4. F3D signalling tone mode.
 - 1) Select the signalling audio tone test mode pursuant to "Tune-up procedure".
 - 2) The occupied bandwidth is drawn from the spectrum analyzer display.

4.3.5 Spurious and Harmonic Emissions at Antenna Terminal.

Test Set-up

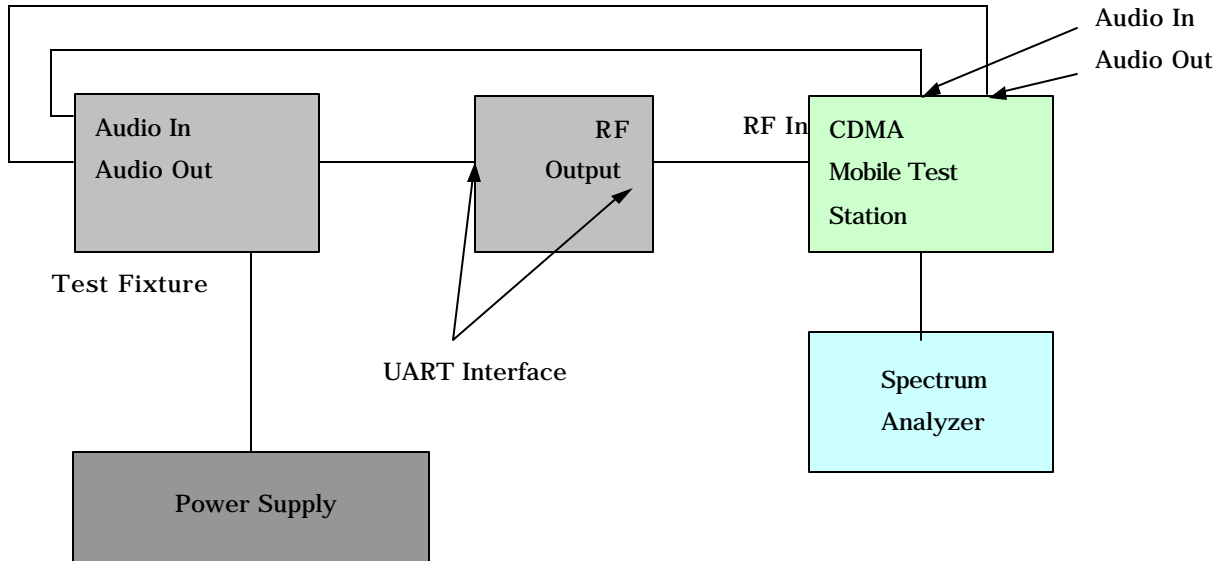

Test Procedure

The level of the carrier and the various conducted spurious and harmonic frequencies is measured by means of a calibrated spectrum analyzer. The spectrum is scanned from the lowest frequency generated in the equipment up to 10 GHz. The transmitter is modulated with a 2500Hz tone at a level of 16dB greater than that required to provide 50% modulation. At the input terminals of the spectrum analyzer, an isolator (RF circulator with one port terminated with 50 ohms) and an 870 MHz to 890 MHz bandpass filter is connected between the test transceiver (for conducted tests) or the receive antenna (for radiated tests) and the analyzer. The rejection of the bandpass filter to signals in the 825 — 845 MHz range is adequate to limit the transmit energy from the test transceiver which appears to a level which will allow the analyzer to measure signals less than —90dBm. Calibration of the test receiver is performed in the 870 — 890 MHz range to insure accuracy to allow variation in the bandpass filter insertion loss to be calibrated.

4.3.6 Field strength of spurious radiation .

Test Set-up

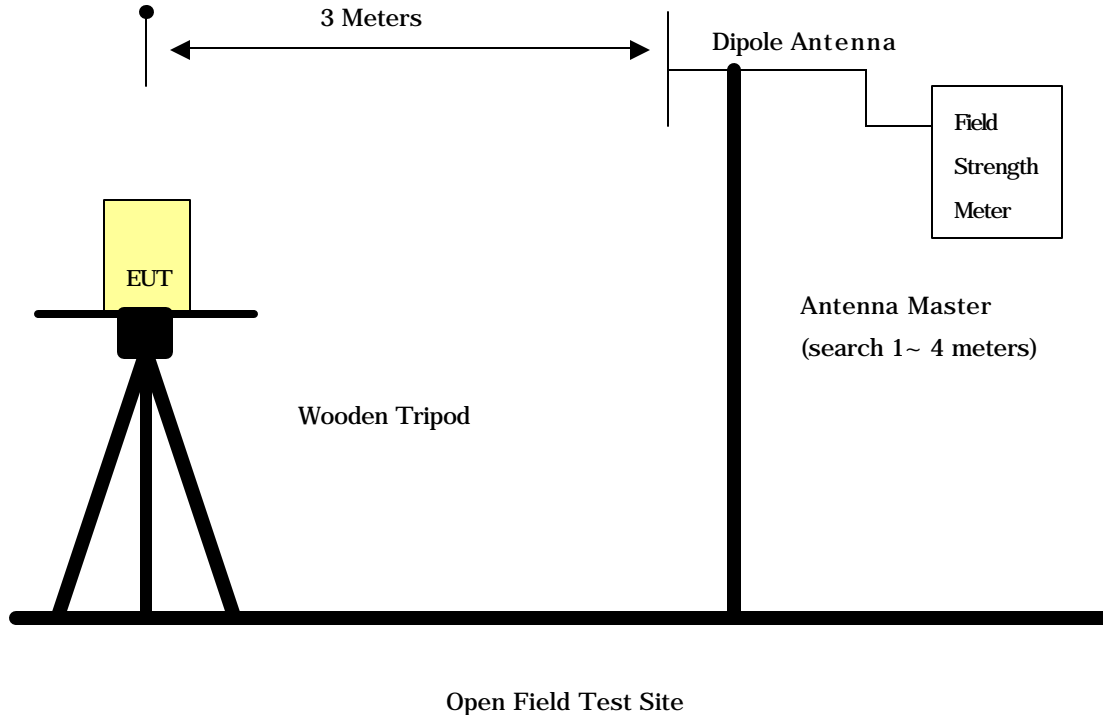

Test Procedure

The measurement facilities used for this test have been documented in previous filings with the commission pursuant to section 2.948.

The open field test site is situated in open field with ground screen whose site attenuation characteristics meet ANSI C63.4 – 1992. A mast capable of lifting the receiving antenna from a height of one to four meters is used together with a rotatable wooden platform mounted at three from the antenna mast.

- 1) The unit mounted on a wooden table 1.5m × 1.0m × 0.80 is 0.8 meter above test site ground level.
- 2) During the emission test , the turntable is rotated and the EUT is manipulated to find the configuration resulting in maximum emission under normal condition of installation and operation.
- 3) The antenna height and polarization are also varied from 1 to 4 meters until the maximum signal is found.
- 4) The spectrum shall be scanned up to the 10th harmonic of the fundamental frequency.
- 5) The instrument settings used (RBW/ VBW) during ERP/ EIRP output power measurement are as follows ;
 - Below 1GHz : RBW 100KHz, VBW 300KHz
 - Above 1GHz : RBW 1MHz, VBW 1MHz

4.3.7 Frequency stability .

4.3.7.1 Frequency stability with variation of ambient temperature.

Test Set-up

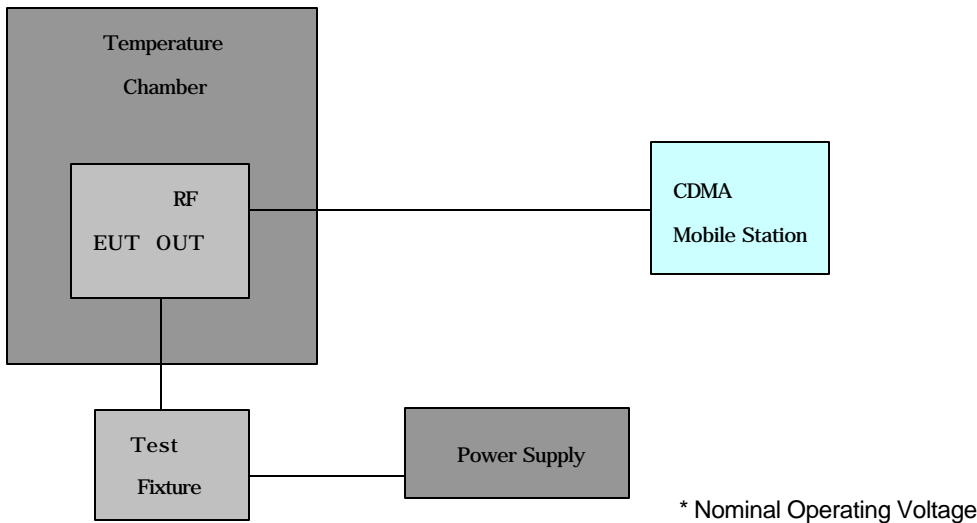

Test Procedure

The frequency stability of the transmitter is measured by:

- Temperature:** The temperature is varied from -30 °C to +60 °C using an environmental chamber.
- Primary Supply Voltage:** The primary supply voltage is varied from 85% to 115% of the voltage normally at the input to the device or at the power supply terminals if cables are not normally supplied.

Specification — The frequency stability shall be sufficient to ensure that the fundamental emission stays within the authorized frequency block. The frequency stability of the transmitter shall be maintained within ± 0.0001 (± 1 ppm) of the center frequency.

Time Period and Procedure:

- The carrier frequency of the transmitter and the individual oscillators is measured at room temperature (25 °C to 27 °C to provide a reference).
- The equipment is subjected to an overnight “soak” at -30 °C without any power applied.
- After the overnight “soak” at 30 °C (usually 14-16 hours), the equipment is turned on in a “standby” condition for one minute before applying power to the transmitter. Measurement of the carrier frequency of the transmitter and the individual oscillators is made within a three minute interval after applying power to the transmitter.
- Frequency measurements are made at 10 °C interval up to room temperature. At least a period of one and one half-hour is provided to allow stabilization of the equipment at each temperature level.
- Again the transmitter carrier frequency and the individual oscillators is measured at room temperature to begin measurement of the upper temperature levels.
- Frequency were made at 10 intervals starting at 30 °C up to +50 °C allowing at least two hours at each temperature for stabilization. In all measurements the frequency is measured within three minutes after applying power to the transmitter.
- The artificial load is mounted external to the temperature chamber.

NOTE: The EUT is tested down to the battery endpoint.

4.3.7.2 Frequency stability with variation of primary supply voltage.

Test Set-up

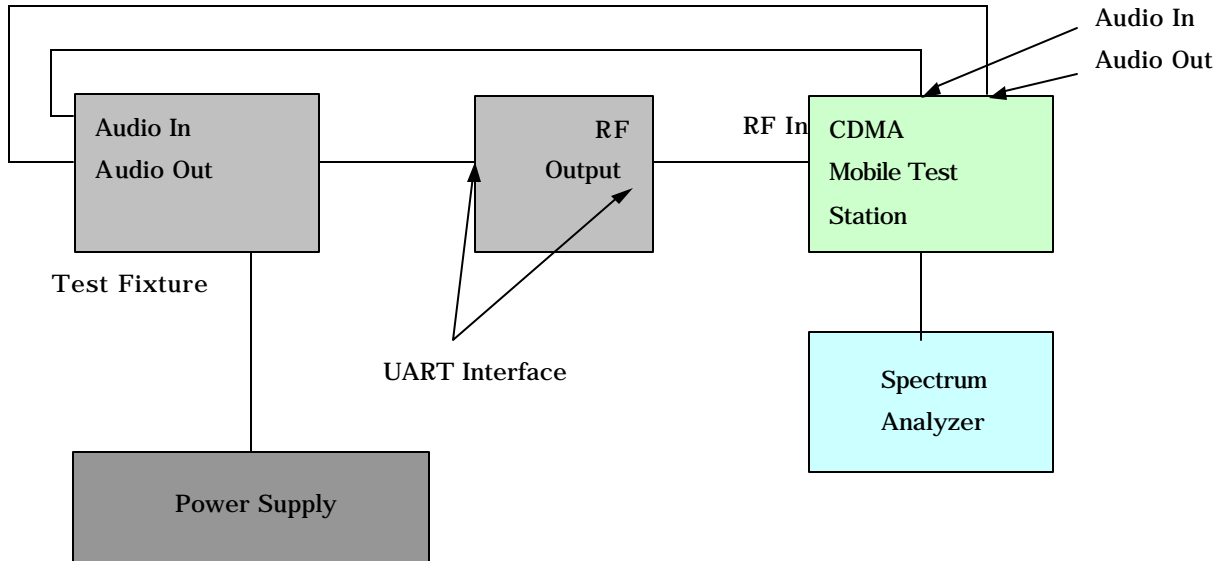

Test Procedure

- 1) The primary supply is varied in steps of 5% from 85 to 115% of the nominal supply voltage, or reduce primary supply voltage to the battery operating end point.
- 2) The frequency is recorded each 5% step.

5.1 Test Data (Continued)

5.1 Equivalent Isotropic Radiated Power (E.I.R.P.) PCS CDMA

Radiated measurements at 3 meters

Modulation: PCS CDMA

Freq. Tuned (MHz)	RFF. LEVEL (dBm)	POL (H/V)	Azimuth (0 angle)	BRP (W)	EIRP (dBm)	BATTERY
1851.25	-9.84	V	70	0.357	25.531	Standard
1880.00	-9.92	V	70	0.351	25.451	Standard
1908.75	-10.15	V	70	0.333	25.221	Standard

Note: Standard batteries are the only options for this phone

NOTES:

Equivalent Isotropic Radiated Power Measurements by Substitution Method
according to ANSI/TIA/EIA-603-A-2001, Aug. 15, 2001:

The EUT was placed on a wooden turn table 3-meters from the receive antenna. The receive antenna height and turntable rotation was adjusted for the highest reading on the receive spectrum analyzer. A Horn antenna was substituted in place of the EUT. This Horn antenna was driven by a signal generator and the level of the signal generator was adjusted to obtain the same receive spectrum analyzer reading. The conducted power at the terminals of the Horn antenna is measured. The difference between the gain of the horn and an isotropic antenna is taken into consideration and the EIRP is recorded.

6.1 Test Data (Continued)

6.2 CELLULAR PCS CDMA Radiated Measurements

Field Strength of SPURIOUS Radiation

? OPERATING FREQUENCY: _____ 1851.25 MHz _____
 ? CHANNEL: _____ 0025 (Low) _____
 ? MEASURED OUTPUT POWER: _____ 25.531 dBm = 0.357 W _____
 ? MODULATION SIGNAL: _____ CDMA (Internal) _____
 ? DISTANCE: _____ 3 meters _____
 ? LIMIT: $43 + 10 \log_{10} (W) =$ _____ 38.53 dBc _____

Freq. (MHz)	LEVEL @ ANTENNA TERMINALS (dBm)	SUBSTITUTE ANTENNA GAIN (dBi)	CORRECT GENERATOR LEVEL (dBm)	POL (H/V)	(dBc)
3702.50	-34.63	12.4	-22.229	V	47.76

NOTES:

Radiated Spurious Emission Measurements by Substitution Method

according to ANSI/TIA/EIA -603-A-2001, Aug. 15, 2001:

The EUT was placed on a wooden turn table 3-meters from the receive antenna. The receive antenna height and turntable rotation was adjusted for the highest reading on the receive spectrum analyzer. A half-wave dipole was substituted in place of the EUT. This dipole antenna was driven by a signal generator and the level of the signal generator was adjusted to obtain the same receive spectrum analyzer reading. This spurious level is recorded. For readings above 1GHz, the above procedure is repeated using horn antennas and the difference between the gain of the horn and an isotropic or dipole antenna are taken into consideration.

6.1 Test Data (Continued)

6.3 CELLULAR PCS CDMA Radiated Measurements

Field Strength of SPURIOUS Radiation

? OPERATING FREQUENCY: _____ 1880.00 MHz _____
 ? CHANNEL: _____ 0600 (Middle) _____
 ? MEASURED OUTPUT POWER: _____ 25.531 dBm = 0.357 W _____
 ? MODULATION SIGNAL: _____ CDMA (Internal) _____
 ? DISTANCE: _____ 3 meters _____
 ? LIMIT: $43 + 10 \log_{10} (W) =$ _____ 38.53 dBc _____

Freq. (MHz)	LEVEL @ ANTENNA TERMINALS (dBm)	SUBSTITUTE ANTENNA GAIN (dBi)	CORRECT GENERATOR LEVEL (dBm)	POL (H/V)	(dBc)
3760.00	-33.33	12.4	-20.929	V	46.46

NOTES:

Radiated Spurious Emission Measurements by Substitution Method

according to ANSI/TIA/EIA -603-A-2001, Aug. 15, 2001:

The EUT was placed on a wooden turn table 3-meters from the receive antenna. The receive antenna height and turntable rotation was adjusted for the highest reading on the receive spectrum analyzer. A half-wave dipole was substituted in place of the EUT. This dipole antenna was driven by a signal generator and the level of the signal generator was adjusted to obtain the same receive spectrum analyzer reading. This spurious level is recorded. For readings above 1GHz, the above procedure is repeated using horn antennas and the difference between the gain of the horn and an isotropic or dipole antenna are taken into consideration.

6.1 Test Data (Continued)

6.4 CELLULAR PCS CDMA Radiated Measurements

Field Strength of SPURIOUS Radiation

? OPERATING FREQUENCY: _____ 1908.75 MHz _____
 ? CHANNEL: _____ 1175 (High) _____
 ? MEASURED OUTPUT POWER: _____ 25.531 dBm = 0.357 W _____
 ? MODULATION SIGNAL: _____ CDMA (Internal) _____
 ? DISTANCE: _____ 3 meters _____
 ? LIMIT: $43 + 10 \log_{10} (W) =$ _____ 38.53 dBc _____

Freq. (MHz)	LEVEL @ ANTENNA TERMINALS (dBm)	SUBSTITUTE ANTENNA GAIN (dBi)	CORRECT GENERATOR LEVEL (dBm)	POL (H/V)	(dBc)
3817.50	-35.13	12.4	-22.729	V	48.26

NOTES:

Radiated Spurious Emission Measurements by Substitution Method

according to ANSI/TIA/EIA-603-A-2001, Aug. 15, 2001:

The EUT was placed on a wooden turn table 3-meters from the receive antenna. The receive antenna height and turntable rotation was adjusted for the highest reading on the receive spectrum analyzer. A half-wave dipole was substituted in place of the EUT. This dipole antenna was driven by a signal generator and the level of the signal generator was adjusted to obtain the same receive spectrum analyzer reading. This spurious level is recorded. For readings above 1GHz, the above procedure is repeated using horn antennas and the difference between the gain of the horn and an isotropic or dipole antenna are taken into consideration.

7.1 Test Data

7.2 FREQUENCY STABILITY (PCS CDMA)

OPERATING FREQUENCY: 1,880,000.421Hz
 CHANNEL: 0600
 REFERENCE VOLTAGE: 3.7 VDC
 DEVIATION LIM IT: ± 0.00025 % or 2.5 ppm

Voltage (%)	Power (VDC)	Tem p. (?)	Frequency (Hz)	Deviation (%)	Deviation (ppm)
100	115	+20 (Ref)	1,880,000,421	0.000000	0.00000
100		-30	1,880,000,374	0.000002	0.02500
100		-20	1,880,000,543	-0.000006	-0.06489
100		-10	1,880,000,486	-0.000003	-0.03457
100		0	1,880,000,374	0.000002	0.02500
100		+10	1,880,000,462	-0.000002	-0.02181
100		+20	1,880,000,574	-0.000008	-0.08138
100		+30	1,880,000,389	0.000002	0.01702
100		+40	1,880,000,472	-0.000003	-0.02713
100		+50	1,880,000,394	0.000001	0.01436
100		+60	1,880,000,270	0.000008	0.08032
85		97.75	+20	1,880,000,394	0.000001
115	132.25	+20	1,880,000,442	-0.000001	-0.01117
BATT. END POINT	N/A	+20	1,880,000,394	0.000001	0.01436

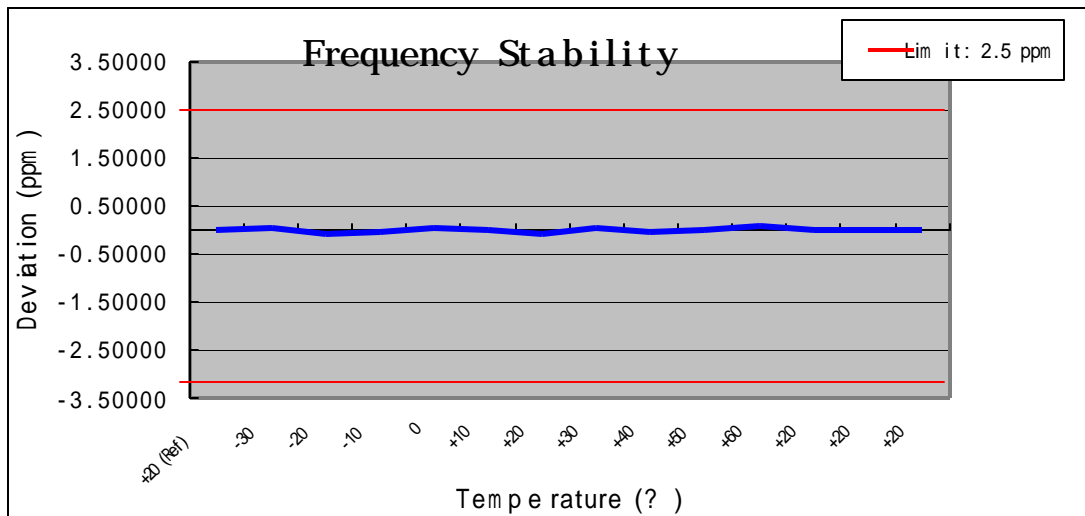

8.1 PLOT(S) OF EMISSION

(SEE ATTACHMENT D)

9.1 LIST OF TEST EQUIPMENT

Type / Model	Calib. Date	S/N
Spectrum Analyzer (20Hz~40GHz) R&S ESI40	Dec. 02	1088.7410
Spectrum Analyzer(100Hz~26.5GHz) R3273	April 03	J04821
Signal Generator HP8373ED (10MHz ~ 20GHz)	July 03	US8710152
Signal Generator MARCONI(10kHz ~ 2.7GHz)	Sep. 03	119331
Power Meter(A) HP 438A	July 03	2822A05909
Power Sensor(A) HP8481B	July 03	3318A08777
Power Meter(B) HP 438A	Nov. 02	2427A00963
Power Sensor(B) HP8481A	Oct. 03	2349A37617
Power Amp A0825-4343-R(800~2.5GHz) +43dB	Sep. 03	A00450
Network Analyzer HP-8753D (30kHz ~ 3GHz)	Sep. 03	3401J02111
Modulation Analyzer HP8901A	June 03	3438A05231
Dipole Antenna UHAP	June 03	557
Dipole Antenna UHAP	June 03	558
AMF-4D-001180-26-10P(0.1~18GHz)	Feb.03	671009
AMF-4D-001180-26-10P(18~26.5GHz)	Feb.03	667624
AMF-4D-001180-26-10P(26~40GHz)	Feb.03	671314
Audio Analyzer HP 8903A	Feb.03	2433A04322
Function Generator HP 8116A	Feb.03	3001A08285
Horn Antenna BBHA 9120D(1~18GHz)	June 03	1099
Horn Antenna BBHA 9120D(1~18GHz)	March 03	1201
Horn Antenna BBHA 9170(15~40GHz)	Feb.03	BBHA9170124
CDMA Mobile Station Test Set HP8924C	June 03	US39063847
PCS Interface HP83236B 1.7 ~ 2.0GHz	June 03	3711J04841
EMI Test Receiver Rohde & Schwarz ESH3	June 03	335.8017
EMI Test Receiver Rohde & Schwarz ESVP	Feb. 03	354.3000
EMI Test Receiver Rohde & Schwarz ESVS30	June 03	826006/013
Spectrum Analyzer HP 8591EM	July 03	3509A00155
LISN EMCO 3825/2	July 03	9706-1070
LISN Rohde & Schwarz ESH2-Z5	July 03	9706-1071
Amplifier Hewlett-Packard 8447E	March 03	2805A03141
Biconical Antenna BBA-9106(30~1000MHz)	June 03	D6901
Log-Periodic Antenna UHALP-9107(300~1000MHz)	June 03	91071107
Antenna VULB 9160 (25MHz~1800MHz)	June 03	91071107
Antenna Position Tower HD240	N.A	3241
Turn Table EMCO 1060-06	N.A	1253A
AC Power Source PACIFIC Magnetic Module	N.A	45321
AC Power Source PACIFIC 360AMX	N.A	22B87

10.1 SAMPLE CALCULATIONS

A. ERP Sample Calculation

Freq. Tuned (MHz)	LEVEL(1) (dBm)	POL (H/V)	ERP (W)	ERP(2) (dBm)	BATTERY
824.70	-29.73	H	0.346	25.393	Standard

- 1) The EUT mounted on a wooden tripod is 0.8 meter above test site ground level.
- 2) During the test , the turn table is rotated and the antenna height is also varied from 1 to 4 meters until the maximum signal is found.
- 3) Record the field strength meter's level.(LEVEL)
- 4) Replace the EUT with dipole antenna that is connected to a calibrated signal generator.
- 5) Increase the signal generator output till the field strength meter's level is equal to the item(3).
- 6) The signal generator output level with cable loss is the rating of effective radiated power(ERP).
(Cable loss means the factor between Signal Generator and Transmitting Antenna.)

For more details, please refer to the test set-up procedure.

B. Emission Designator

Emission Designator = 1M25F9W

CDMA BW = 1.25 MHz

F = Frequency Modulation

9 = Composite Digital Info

W = Combination (Audio/Data)

(Measured at the 99.75% power bandwidth)

11.1 CONCLUSION

The data collected shows that the Fixed WLL Telephone (CDMA) **FCC ID: PH7AXWP1900** complies with all the requirements of Parts 2 and 24 of the FCC rules.