

ALINCO

DR-735T(2)

Instruction Manual

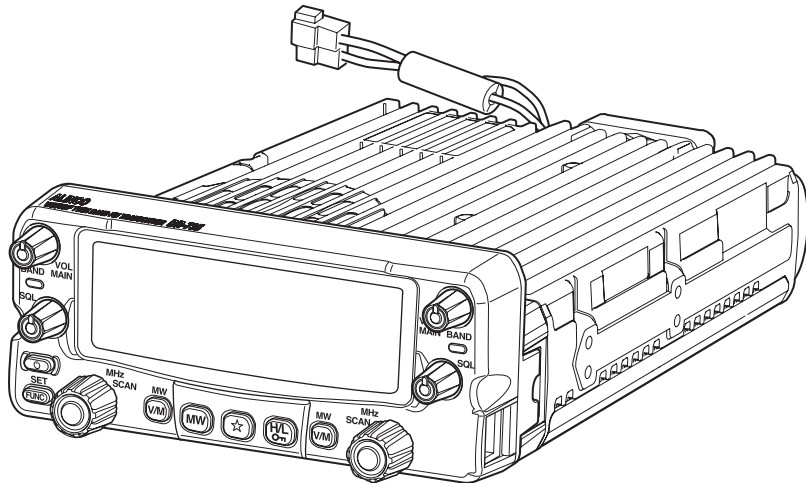

Thank you for purchasing your new Alinco transceiver.
This Instruction manual contains important safety and operating instructions. Please read this manual carefully before using the product and keep it for future reference.

NOTICE / Compliance Information Statement

This equipment has been tested and found to comply with the limits for a Class B digital device, pursuant to part 15 of the FCC Rules.

These limits are designed to provide reasonable protection against harmful interference in a residential installation. This equipment generates, uses, and can radiate radio frequency energy and, if not installed and used in accordance with the instruction manual, may cause harmful interference to radio communications. However, there is no guarantee that interference will not occur in a particular installation. If this equipment does cause harmful interference to radio or television reception, which can be determined by turning the equipment off and on, the user is encouraged to try to correct the interference by one or more of the following measures:

- *Reorient or relocate the receiving antenna.*
- *Increase the separation between the equipment and receiver.*
- *Connect the equipment into an outlet on a circuit different from that to which the receiver is connected.*
- *Consult the dealer or an experienced radio/TV technician for help.*

Changes or modifications not expressly approved by the party responsible for compliance could void the user's authority to operate the equipment.

VHF/UHF FM Transceiver DR-735T(2)

This device complies with Part 15 of the FCC Rules. Operation is subject to the two conditions: (1) This device may not cause harmful interference, and (2) this device must accept any interference received, including interference that may cause undesired operation.

Manufacturer: Alinco Incorporated Electronics Division

Yodoyabashi-Dai building 13th Floor 4-9, 5-Chome, Koraibashi, Chio-ku, Osaka 541-0043, JAPAN



Conformity Information

In case the unit you have purchased is marked with a CE symbol, a copy of relative conformity certificate or document can be reviewed at <http://www.alinco.com/usa.html>. Please see the back-cover for more details.

Copyright © 2016 All right reserved. No part of this document may be reproduced, copied, translated or transcribed in any form or by any means without the prior written permission of Alinco. Inc., Osaka, Japan. English Edition
Printed in Japan.

This device complies with Industry Canada licence-exempt RSS standard(s). Operation is subject to the following two conditions:



- (1) this device may not cause interference, and
- (2) this device must accept any interference, including interference that may cause undesired operation of the device.



Le présent appareil est conforme aux CNR d'Industrie Canada applicables aux appareils radio exempts de licence. L'exploitation est autorisée aux deux conditions suivantes :

- (1) l'appareil ne doit pas produire de brouillage, et
- (2) l'utilisateur de l'appareil doit accepter tout brouillage radioélectrique subi, même si le brouillage est susceptible d'en compromettre le fonctionnement.

WARNING











To prevent any hazard during operation of Alinco's radio product, in this manual and on the product you may find symbols shown below. Please read and understand the meanings of these symbols before starting to use the product.

 Danger	This symbol is intended to alert the user to an immediate danger that may cause loss of life and property if the user disregards the warning.
 Alert	This symbol is intended to alert the user to a possible hazard that may cause loss of life and property if the user disregards the warning.
 Caution	This symbol is intended to alert the user a possible hazard that may cause loss of property or injure the user if the warning is disregarded.

	Alert symbol. An explanation is given.
	Warning symbol. An explanation is given.
	Instruction symbol. An explanation is given.

ALERT

■ Environment and condition of use:

-  Do not drive while handling the radio for your safety. It is recommended that you check local traffic regulations regarding the use of radio equipment while driving. Some countries prohibit the operation of transceiver while driving.
-  Do not use this product in close proximity to other electronics devices, especially medical ones. It may cause interference to those devices.
-  Keep the radio out of the reach of children.
-  In case a liquid leaks from the product, do not touch it. It may damage your skin. Rinse with plenty of cold water if the liquid contacted your skin.
-  Never operate this product in facilities where radio products are prohibited for use such as aboard aircraft, in airports, in ports, within or near the operating area of business wireless stations or their relay stations.
-  Use of this product may be prohibited or illegal outside of your country. Be informed in advance when you travel.
-  The manufacturer declines any responsibilities against loss of life and/or property due to a failure of this product when used to perform important tasks like life-guarding, surveillance, and rescue.
-  Do not use multiple radios in very close proximity. It may cause interference and/or damage to the product(s).
-  Risk of explosion if battery is replaced with an incorrect type. Dispose of, or recycle used batteries according to your local regulations.
-  The manufacturer declines any responsibilities against loss of life and property due to a failure of this product when used with or as a part of a device made by third parties.
-  Use of third party accessory may result in damage to this product. It will void our warranty for repair.

■ **Handling this product:**

- ⚠ Be sure to reduce the audio output level to minimum before using an earphone or a headset. Excessive audio may damage hearing.
- ⊘ Do not open the unit without permission or instruction from the manufacturer.
- ⊘ Unauthorized modification or repair may result in electric shock, fire and/or malfunction.
- ⊘ Do not operate this product in a wet place such as shower room. It may result in electric shock, fire and/or malfunction.
- ⊘ Do not place conductive materials, such as water or metal in close proximity to the product. A short-circuit to the product may result in electric shock, fire and/or malfunction.
- ⊘ Do not touch the heatsink (on/around the unit mostly found on mobile-base units) as it may become very hot during/after the operation that may risk burn your skin.

■ **About power-supply:**

- ⚠ Use only appropriate, reliable and certified power supply of correct voltage and capacity.
- ⊘ Do not connect cables in reverse polarity. It may result in electric shock, fire and/or malfunction.
- ⊘ Do not plug multiple devices including the power-supply into a single wall outlet. It may result in overheating and/or fire.
- ⊘ Do not handle a power-supply with a wet hand. It may result in electric shock.
- ⚠ Securely plug the power-supply to the wall outlet. Insecure installation may result in short-circuit, electronic shock and/or fire.
- ⊘ Do not plug the power-supply into the wall outlet if the contacts are dirty and/or dusty.
- ⊘ Shortcircuiting and/or overheating may result in fire, electric shock and/or damage to the product.
- ⊘ Do not modify or remove fuse-assembly from the DC-cable. It may result in fire, electric shock and/or damage to the product.

■ **In case of emergency:**

In case of the following situation(s), please turn off the product, switch off the source of power, then remove or unplug the power-cord. Please contact your local dealer of this product for service and assistance. Do not use the product until the trouble is resolved. Do not try to troubleshoot the problem by yourself.

- When a strange sound, smoke and or strange odor comes out of the product.
- When the product is dropped or the case is broken or cracked.
- When a liquid penetrated inside.
- When a power-cord (including DC-cables, AC-cables and adapters) is damaged.





- ⚠ For your safety, turn off then remove all related AC-lines to the product and its accessories including the antenna if a thunderstorm is likely.
- ⚠ Turn off the unit, remove the mobile antenna from its base and keep it in the vehicle if a thunderstorm is likely.
Please read cautions regarding the lightning-protection on page 9 also.

■ Maintenance

-  Do not open the unit and its accessories. Please consult with your local dealer of this product for service and assistance.

CAUTION





■ Environment and condition of use:

-  Do not use the product in proximity to a TV or a radio. It may cause interference or receive interference.
-  Do not install in a humid, dusty or insufficiently ventilated place. It may result in electric shock, fire and/or malfunction.
-  Do not install in an unstable or vibrating position. It may result in electric shock, fire and/or malfunction when/if the product falls to the ground.
-  Do not install the product in proximity to a source of heat and humidity such as a heater or a stove. Avoid placing the unit in direct sunlight.





 Do not modify, dismantle, incinerate, or immerse the batteries. That may be used in accessories you use with this product.

Please check your local regulations for details on recycling option or disposal of the batteries in your area.

■ About transceiver

-  Do not connect devices other than specified ones to the jacks and ports on the product. It may result in damage to the devices.
-  Turn off and remove the power-source (AC cable, DC cable, battery, cigar-cable, charger adapter etc) from the product when the product is not in use for extended period of time or in case of maintenance.
-  Never pull the cord alone when you unplug AC cable from the wall outlet.
-  Use a clean, dry cloth to wipe off dirt and condensation from the surface of the product. Never use thinner or benzene for cleaning.

■ About power-supply

-  Use only reliable power supply of specific DC output range and be mindful of the polarity of the cables and DC jack.
-  Always turn off the power supply when connecting or disconnecting the cables.
-  When using an external antenna, make sure that the antenna ground is not common with the ground of the power supply.
-  European users: When a transceiver is powered from an external DC power source (adapter, power supply, cigar-plug etc), make sure that this power supply has approval to the level of IEC/EN 60950-1.

Before Operating the Transceiver

Attention

- Do not remove the case or touch the interior components. Tampering can cause equipment trouble.
- Do not use or keep the transceiver where it is exposed to direct sunlight, dusty places, or near sources of heat.
- When transmitting for long periods of time at high power, the transceiver might overheat. This product is NOT a 100%-duty transmitter.
- Turn the power off immediately if the transceiver emits smoke or strange odors. Ensure the transceiver is safe, then bring it to the nearest Alinco service center.
- An operator's license is required for this device.

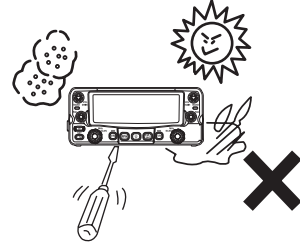

Notice to California resident users

The product that comes with this manual is free from dangerous material such as lead and cadmium as per RoHS order of EU.

The transceiver has no protection against lightning.

The user is responsible for providing adequate protection if he/she uses the device at home and installs the antenna outdoor. Be aware that any outdoor antenna creates a direct path for lightning current (more than 10kA) to the transceiver. This path exists whether the device is turned ON or OFF.

Any vehicle does not present a safe environment during lightning. This environment becomes much more dangerous if an outdoor antenna is installed on the car. Move the antenna and its cable into the car at the first sight of forthcoming thunderstorm and lightning.

Introduction

Thank you very much for purchasing this excellent Alinco transceiver. Our products are ranked among the finest in the world. This radio has been manufactured with state of the art technology and it has been tested carefully at our factory. It is designed to operate to your satisfaction for many years under normal use.

PLEASE READ THIS MANUAL COMPLETELY TO LEARN ALL THE FUNCTIONS THE PRODUCT OFFERS. WE MADE EVERY ATTEMPT TO WRITE THIS MANUAL TO BE AS COMPREHENSIVE AND EASY TO UNDERSTAND AS POSSIBLE. IT IS IMPORTANT TO NOTE THAT SOME OF THE OPERATIONS MAY BE EXPLAINED IN RELATION TO INFORMATION IN PREVIOUS CHAPTERS. BY READING JUST ONE PART OF THE MANUAL, YOU RISK NOT UNDERSTANDING THE COMPLETE EXPLANATION OF THE FUNCTION.

Before operating the transceiver

Introduction

Thank you very much for purchasing this excellent Alinco transceiver. Our products are ranked among the finest in the world. This radio has been manufactured with state of the art technology and it has been tested carefully at our factory. It is designed to operate to your satisfaction for many years under normal use.

PLEASE READ THIS MANUAL COMPLETELY TO LEARN ALL THE FUNCTIONS THE PRODUCT OFFERS. WE MADE EVERY ATTEMPT TO WRITE THIS MANUAL TO BE AS COMPREHENSIVE AND EASY TO UNDERSTAND AS POSSIBLE. IT IS IMPORTANT TO NOTE THAT SOME OF THE OPERATIONS MAY BE EXPLAINED IN RELATION TO INFORMATION IN PREVIOUS CHAPTERS. BY READING JUST ONE PART OF THE MANUAL, YOU RISK NOT UNDERSTANDING THE COMPLETE EXPLANATION OF THE FUNCTION.

Standard Accessories

Carefully unpack to make sure the following items are found in the package in addition to this manual.

■ Transceiver

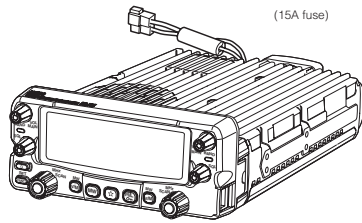

■ EMS79 (with DTMF keypad)

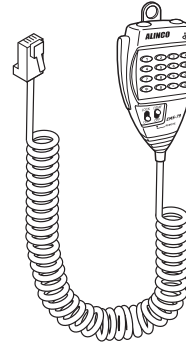

■ DC power cable including 15A fuse and holder

UA0038Y

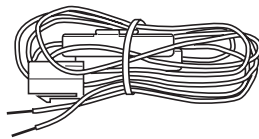

■ Mobile Mounting bracket

FM0078Z

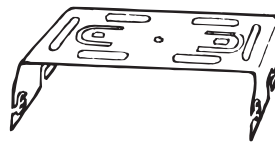

■ Hardware kit for bracket

Bracket screws
AE0012
(M4 x 8mm) x 4



Tapping screws
(M5 x 20mm) x 4



Screws
(M5 x 20mm) x 4



Hexagonal nut
(M5) x 5



■ Small (spanner) wrench



■ Instruction manual

The standard accessories may vary slightly depending on the version you have purchased.

Please contact your local authorized Alinco dealer should you have any questions.

Standard accessories may change without notice.

■ Warranty Policy

Please refer to any enclosed warranty information or contact your authorized Alinco dealer/distributor for the warranty policy before purchase.

Initial Installation

Microphone connection

Connect the microphone plug into microphone terminal on the right side of control panel or into other microphone terminal in front of MAIN unit. Insert the plug until hearing a click.

IMPORTANT When connecting, take care to the modular plug direction.

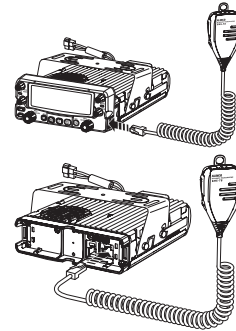

Antenna Connection

Connect antenna port to 50Ω antenna that covers 2m/70cm bands, using good quality 50Ω coaxial cable.

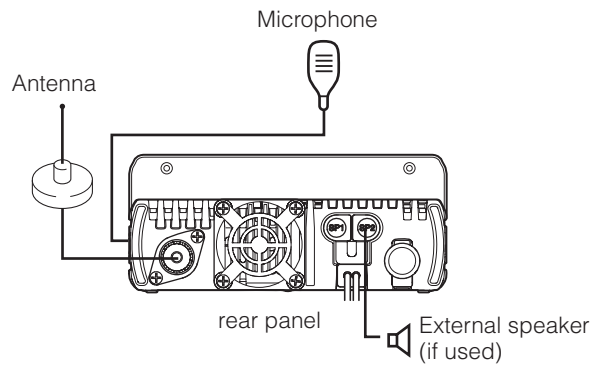

IMPORTANT Coupling the antenna to the transceiver via feed-lines having impedance other than 50Ω reduces the efficiency of the antenna system and can cause interference to nearby televisions, radio receivers and other electronic equipment.

For a base station set up

IMPORTANT

- Before connecting, be sure to turn off the transceiver and DC power supply.
- Be certain to use DC cable provided with unit.

The transceiver requires 13.8V DC negative grounded power supply. Use a regulated power supply capable of providing continuous current of 12A or more. Power supplies that do not meet these specifications may cause malfunction and/or damage to the radio and will void the warranty. Alinco offers excellent communication-grade power supplies as optional accessories. Please contact your local authorized Alinco dealer.

DC voltage range for operating this transceiver is DC 11.7V to 15.8V.

IMPORTANT Transceiver will not operate out of this range. Inspect cable and connection regularly to be sure there is not any damage or burning.

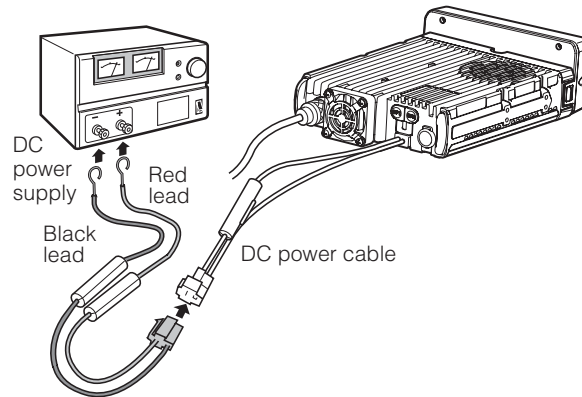

For mobile station set up

Location

The transceiver may be installed in any position in your vehicle, where the controls and microphones are easily accessible and it does not interfere with the safe operation of the vehicle or the performance of the set. If your vehicle is equipped with air bag, be certain your radio will not interfere with their deployment. If you are uncertain about where to mount the unit, contact your vehicle's manufacture.

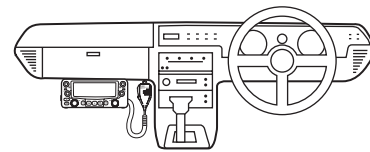

Front Panel

The main unit can be set with either side facing up. This can facilitate your ability to hear the speaker's audio clearly. Position the front panel as you prefer.

1. **Slide the front panel while pulling the tab toward yourself.**
2. **Turn the front panel, being careful to keep the cable free from kinks.**
3. **Match the catch in the main unit with the slot in the front panel and fit the front panel into the main unit.**
4. **Slide the front panel unit until it locks securely in place.**

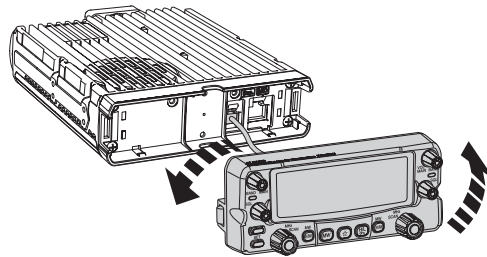
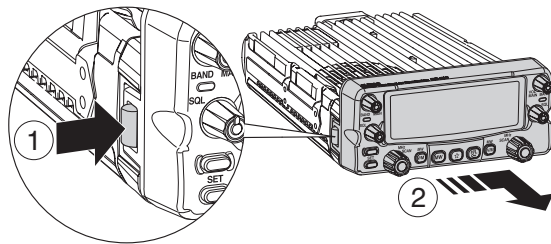

④ Match the catch in the main unit with the slot in the front panel and fit the front panel into the main unit.

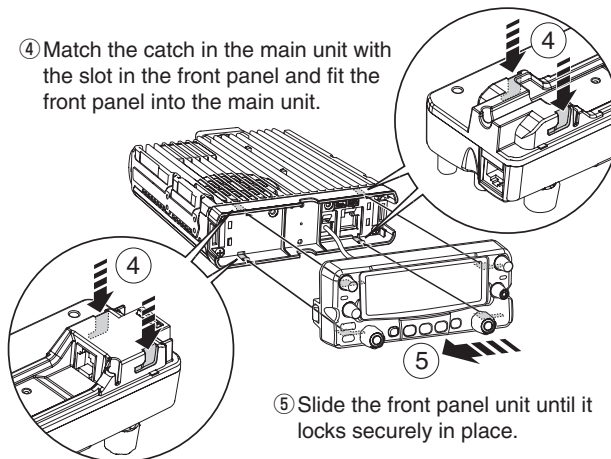

⑤ Slide the front panel unit until it locks securely in place.



NOTE

By using the optional separation kit EDS-30, you can use the control and the main unit in separate positions. The length of separation cable is 5m. See page 75 for details.

Installing a Mobile Antenna

Use a 50Ω coaxial cable to connect the antenna. Mobile antennas require an appropriate mounting base for proper installation and operation. For more information, see the documentation for your antenna.

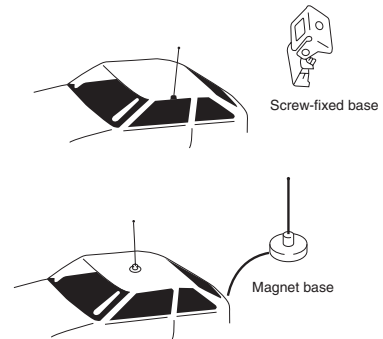

IMPORTANT

After installing your antenna, ensure that you have the best possible SWR reading. High RF environments can cause severe damage to your unit. Ensure that you are not in a high RF environment when operating the transceiver.

Using the mounting bracket

1. **Drill 4 holes where the mounting bracket is to be installed.**

. Approx. 5.5-6mm (1/4") when using nuts; approx. 2-3 mm (1/8") when using self-tapping screws.

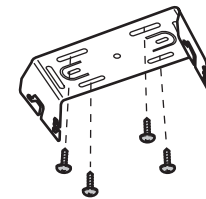

<For making 4+/-0.2mm hole in globe box bottom>

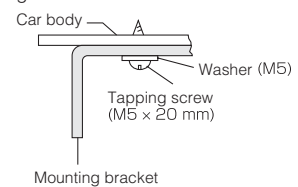

2. **Insert the supplied screws, nuts and washers through the mounting bracket and tighten.**
3. **Adjust the angle for your suitable position.**

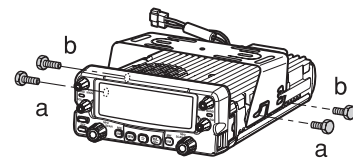

Controls, Connectors, and Display

Control Keys Operation Methods

There are 3 types of key operations; simply press, press after pressing [FUNC] key while FUNC appears on the display, or press and hold.

- [Press] refers to one time quick press and remove finger.
- [FUNC + this Key] refers to one time press [FUNC] key and then pressing this key while FUNC appears on the display.
- [Press and hold] refers to press key and hold it. Hold timing is adjustable in set mode; however factory default is 2 sec.

To confirm a parameter, [press any keys other than these keys] or [press microphone's PTT switch] are mentioned in this instruction manual. Quickest way to confirm parameters is pressing microphone's PTT switch.

Front Panel

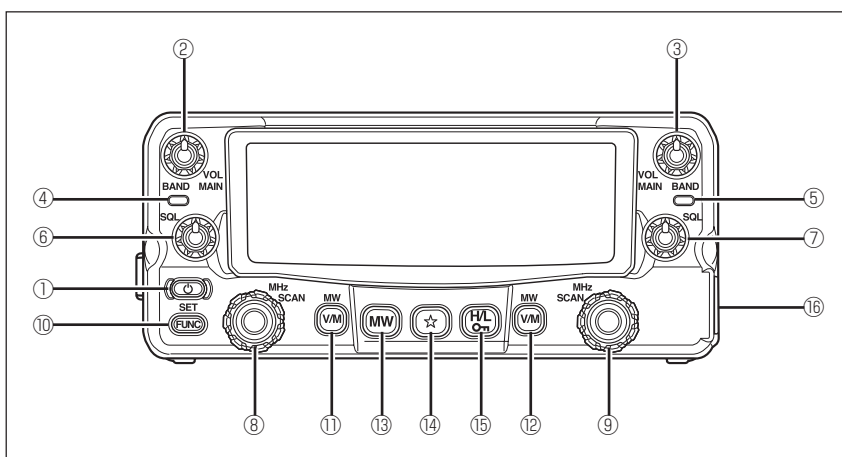

■ Primary Functions

No.	Key	Function
①	Power Key	Turns the power on/off. (P.19)
②	Left band [VOL] knob	Rotate to adjust audio sound level on the left band. (P.19)
③	Right band [VOL] knob	Rotate to adjust audio sound level on the right band. (P.19)
④	Left band TX/RX indicator	Indicates transmission (Red) or reception (Green) on the left band.
⑤	Right band TX/RX indicator	Indicates transmission (Red) or reception (Green) on the right band.
⑥	Left band [SQL] knob	Rotate to adjust squelch level on the left band. (P.20)
⑦	Right band [SQL] knob	Rotate to adjust squelch level on the right band. (P.20)
⑧	Left band dial	Rotate to select frequency, memory channel and various settings on the left band.
⑨	Right band dial	Rotate to select frequency, memory channel and various settings on the right band.
⑩	[FUNC] key	Sets functions.
⑪	Left band [V/M] key	Switches between VFO mode and memory mode on the left band.
⑫	Right band [V/M] key	Switches between VFO mode and memory mode on the right band.
⑬	[MW] key	Press to select dual Memory mode.
⑭	★ key	Programmable function key.(P.63)
⑮	[H/L] key	Press to select Hi/Mid and Low output power. (P.33)
⑯	Microphone connector	For connecting microphone.

■ Functions that requires press and holding to be activated

No.	Key	Function
②	Left band [VOL] knob	Switches between VHF/Air-Band and UHF on the left band (P.19)
③	Right band [VOL] Knob	Switches between UHF/VHF and Air-Band on the right band (P.19)
⑧	Left band dial	Switches between VFO and memory scan on the left band. (P.58)
⑨	Right band dial	Switches between VFO and memory scan on the right band. (P.58)
⑩	[FUNC] key	Sets mode. (P.34)
⑪	Left-Band [V/M] key	Switches to Call channel on the Left-Band. (P.30)
⑫	Right-Band [V/M] key	Switches to Call channel on the Right-Band. (P.30)
⑬	[MW] key	Simple Memory writing. (P.24)
⑮	[H/L] key	Key lock. (P.62)

* Hold timing is adjustable in set mode

■ Functions which can be activated while [FUNC] appears, after pressing [FUNC] key

No.	Key	Function
②	Left band [VOL] knob	Switches to the single band mode on the left band. (P.57)
③	Right band [VOL] knob	Switches to the single band mode on the right band. (P.57)
⑧	Left band dial	Program scan on the left band. (P.60)
⑨	Right band dial	Program scan on the right band. (P.60)
⑪	Left band [V/M] key	Write frequency to selected memory on the left band. (P.23)
⑫	Right-Band [V/M] key	Write frequency to selected memory on the right band. (P.23)
⑬	[MW] key	Sets monitor function. (Reverse function when shift activated). (P.31)
⑭	★ key	Selects Tone-squelch (CTCSS) or DCS. (P.64)
⑮	[H/L] key	Accesses the digital voice communication mode (required optional unit) (P.66)

■ Functions which can be activated while pressing the [FUNC] key

No.	Key	Function
①	⏻ Power key	Normal Reset when turns the power on. (P.73)
②	Left band [VOL] knob	Selects shift or offset frequency on the left band. (P.22)
③	Right band [VOL] knob	Selects shift or offset frequency on the right band. (P.22)
⑧	Left band dial	Sets priority scan on the left band. (P.60)
⑨	Right band dial	Sets priority scan on the right band. (P.60)
⑪	Left band [V/M] key	Erase the memory while memory mode is selected on the left band. (P.25)
⑫	Right band [V/M] key	Erase the memory while memory mode is selected on the right band. (P.25)
⑬	[MW] key	Sets auto-dialer memory. (P.74)
⑭	★ key	Sets RGB backlight color. (P.63)
⑮	[H/L] key	Sets the channel name while Memory mode selected. (P.28)

Rear Panel

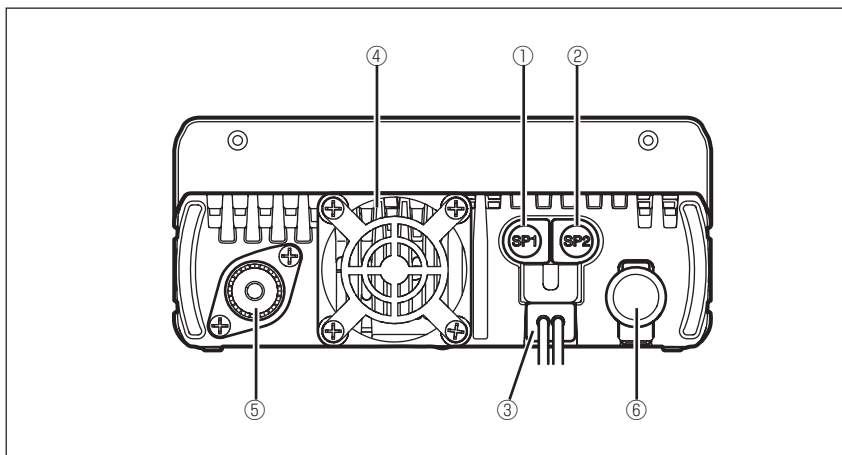

No.	Key	Function
①	External Speaker Jack 1 [SP1]	Connects an external 8Ω speaker. Output audio from right band. When another speaker is not connected to [SP2], left band audio hear through internal speaker. Also [SP1] used for connecting clone or PC cables.
②	External Speaker Jack 2 [SP2]	Connects an external 8Ω speaker. Output audio from left band. When another speaker is not connected to [SP1], right band audio hear through internal speaker.
③	DC Power cable	Connects to the 13.8V DC power supply.
④	Air-cooling fan	Cools the unit during transmission or when radio is holding high temperature.
⑤	Antenna connector	Connects to antenna with 50Ω impedance matched with operation frequency.
⑥	DIN connector (6 PIN)	Connects to external TNC unit for Packet communications.

Antenna Connection

Before operating, install an efficient, well-tuned antenna. The success of your installation will depend on the type of antenna and its correct installation. Use a 50Ω impedance antenna and low-loss coaxial feed-line that has a characteristic impedance of 50Ω, to match the transceiver input impedance. Coupling the antenna to the transceiver via feed-lines having impedance other than 50Ω reduces the efficiency of the antenna system and can cause interference to nearby televisions, radio receivers and other electronic equipment.



Transmitting without first connecting an antenna or other matched load may damage the transceiver. Always connect the antenna to the transceiver before transmitting. All fixed stations should be equipped with a lightning protection to reduce the risk of fire, electric shock, and transceiver damage.

External Speaker Connection

- If you plan to use an external speaker, choose a speaker with an impedance of 8Ω. Each external speaker jacks accept a 3.5mm (1/8") mono (2-conductor) plug.
- External speaker adopt double port BTL, please care about the connection. Do not use the speaker that requires grounding.
- Carefully insert plug into jack. Do not twist the plug and do not apply stress on speaker jack.
- When jacks are not in use, keep the [SP] cap (speaker jack cover) closed to keep contacts clean and avoid entering dust and other objects into the radio.
- Insert plug into jack completely until end to prevent damaging the jack or plug.

Display

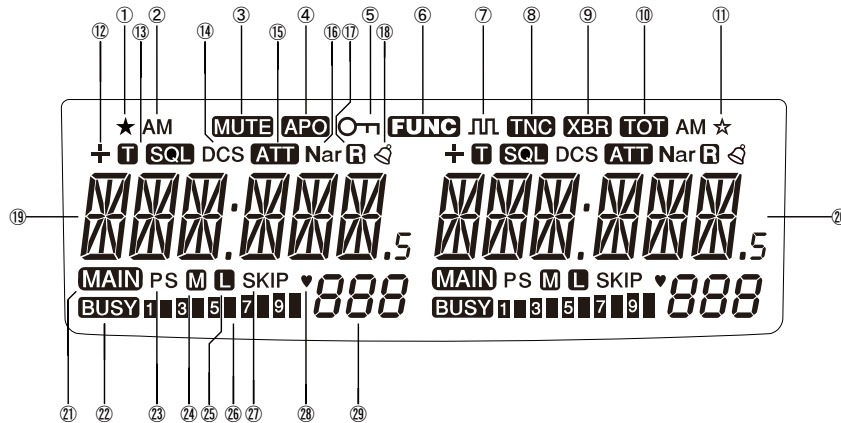

No.	Key	Function
①	★	Appears when advanced set mode is available. (P.48)
②	AM	Appears during AM reception. (P.36)
③	MUTE	Appears during transmission when other band is set for mute. (P.52)
④	APO	Appears when APO function is activated. (P.49)
⑤	🔒	Appears when setting the key lock. (P.62)
⑥	FUNC	Appears when [FUNC] key is pressed. (P.17)
⑦	⏏	Appears when in the digital voice communication mode. (P.66)
⑧	TNC	Appears when in packet mode. (P.55)
⑨	XBR	Appears when cross-band repeater mode is available.
⑩	TOT	Appears during time out timer setting. (P.49)
⑪	★	Appears during short cut setting. (P.63)
⑫	+ -	Appears when setting the shift. (P.22)
⑬	T SQL	Appears when setting the tone squelch. (P.64)
⑭	DCS	Appears when setting the DCS. (P.65)
⑮	ATT	Appears when attenuator function is activated. (P.44)
⑯	Nar	Appears when in narrow band reception mode. (P.36)
⑰	R	Appears when reverse mode is activated. (P.32)
⑱	📶	Appears when Bell function is activated. (P.39)
⑲	123.456.5	Indicates the VHF/UHF frequency or memory name on the left band side. (P.20, 31)
⑳	123.456.5	Indicates the VHF/UHF frequency or memory name on the right band side. (P.20, 31)
㉑	MAIN	Appears on the band with transmitting ability. (P.19)
㉒	BUSY	Appears when a signal is being received. (P.31)
㉓	PS	[S] Flashes during scan and [PS] flashes during program scan. (P.58)
㉔	M	Appears when transmission power is set to MID. (P.33)
㉕	L	Appears when transmission power is set to LOW. (P.33)
㉖	S meter	Indicates received or transmitted signal level. (P.31, 32)
㉗	SKIP	Appears during scan for skip channels. (P.59)
㉘	♥	Appears when favorite channel is selected. (P.59)
㉙	888	Indicates memory numbers in the memory mode. (P.23)

Microphone EMS-79

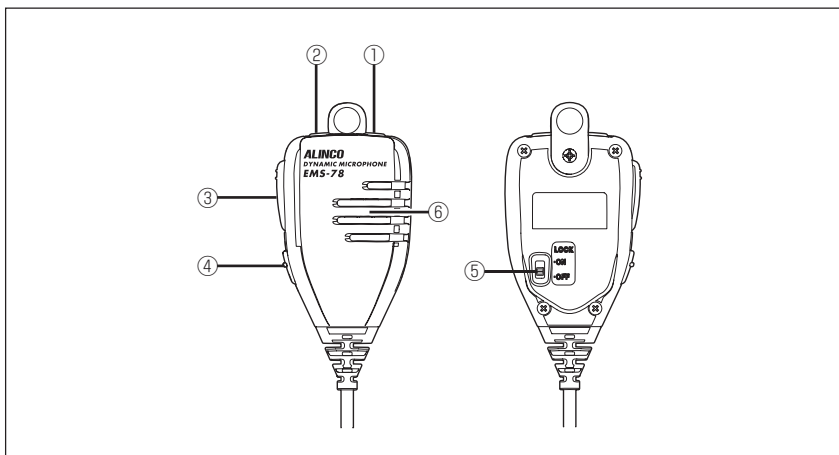

No.	Key	Function
①	UP	Increase the frequency, memory channel number, or setting value.
②	DOWN	Decrease the frequency, memory channel number, or setting value.
③	MAIN PTT	Press the PTT (Push-To-Talk) key to transmit. Also press this key to confirm your selection.
④	SUB PTT	Press the PTT (Push-To-Talk) key to transmit on sub band. Also used for other functions depends on setting in set mode. (P.45)
⑤	LOCK SWITCH	Locks out the UP and DOWN keys.
⑥	MIC	Speak here during transmission.

■ Microphone Connector pin Assignment (Viewed from front of unit)

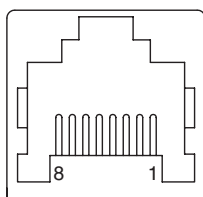

- 1.DC5V
- 2.DOWN
- 3.REMOTE
- 4.PTT
- 5.MIC GND
- 6.MIC
- 7.GND
- 8.UP

IMPORTANT

- Connect the microphone modular plug provided with the unit into microphone jack.
- Insert the plug until hearing a click. When connecting, take care to the modular plug direction.
- When removing microphone from unit, press the lock on connector then pull the plug out. Do not pull the microphone's cable to remove the microphone from radio.
- When using optional EDS-8 (8 pin to modular convertor), fix EDS-8 cable on the bracket to avoid stress on modular socket.
- Be careful to not mis-connecting separation cable to microphone's modular socket.

Basic Operations

Turning the unit on and off

By press and holding the PWR key the power is turned on. By press and holding the PWR key again, the power is turned off. To avoid accidentally turn on/off, PWR key operation is designed for press and hold.

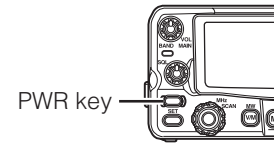

Switching the MAIN band

In this instruction manual the MAIN band refers to the band which selected for transmitting with MAIN icon on the display. To select MAIN band press left or right volume knob. Press main PTT switch on microphone to transmit on the MAIN band.



For transmit on sub band without switching MAIN, set SUB-PTT switch on EMS-78 microphone for TX in set mode. (P.45)
During memory scan (P.59), receiving band becomes MAIN band automatically.

Switching operation band

Press and hold VOL knob for changing band (frequency). By press and holding VOL knob, VHF->Air-Band VHF->UHF appears on the display.

Also selecting same band for left and right is possible. (V-V or U-U reception)

[AM] appears on the display when Air-band selected as factory default setting.

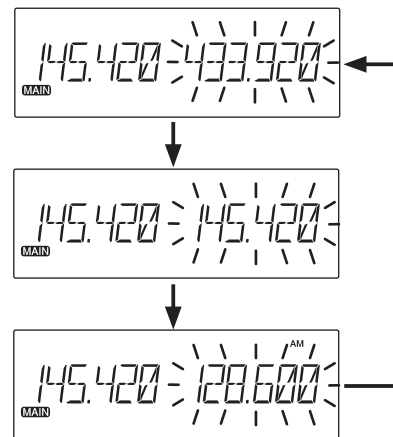

IMPORTANT

When V-V/U-U/V-Air-band is selected, during transmission on main band reception on sub band becomes mute.

Audio Volume level setting

The volume of the left band is adjusted by the left VOL knob and the volume of the right band by the right VOL knob.

Rotate the VOL knob clockwise to increase the audio level, counterclockwise to decrease.

Low Volume High Volume Low Volume High Volume

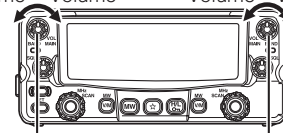

VOL knob for left band

VOL knob for right band

Squelch level setting

Adjust threshold level of the squelch. A squelch eliminates the background noise when a signal is not received.

Turn the SQL knob clockwise until white-noise (the background noise when a signal is not received) and [BUSY] icon on the display disappears.

The SQL should be turned fully counterclockwise when receiving weak or unstable signals. The [BUSY] icon appears on the display while the squelch is opened (unmuted).

When you set it to a higher level, weak signals would be interrupted while monitoring or would not be monitored at all.

Generally, you should set the squelch to the lowest level where noise would be eliminated. Depending on the monitored frequencies and the conditions of the circumstances around you, the squelch level may need to be adjusted

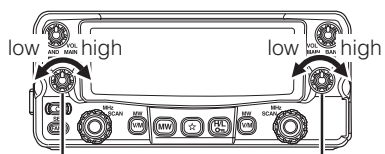

SQL knob for left band

VOL knob for Right band



NOTE

Attenuator function is available for SQL knob. (P.44)

To receive signals

1. **Be sure to have the unit connected to the appropriate antenna, powered on, set the audio volume and squelch level properly on both the MAIN and SUB bands.**
2. **Select the desired band and browse frequencies or select desired frequency to listen to ongoing communications. The S-meter shows relative signal strength when the transceiver detects an incoming signal, and the RX indicator lamp (green) turns on.**
3. **If the S-meter indicates an incoming signal but nothing is heard from the speaker, check the audio level, squelch level, and CTCSS/DCS decoding status, which are explained elsewhere in this manual.**

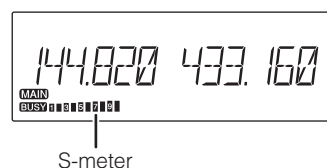

Monitor Function

This function is used to listen to weak signals. The monitor function operates irrespective of Tone squelch / DCS functions setting.

Select desired band as MAIN. Press FUNC key then press MW key while [FUNC] appears on the display.

Regardless of the level setting of the squelch, it will be opened; BUSY icon flash and RX lamp will turn on.

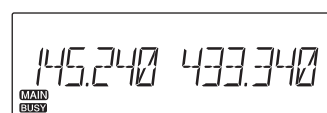

4. **Press any key on the front panel to exit.**

IMPORTANT The Monitor function only operates on the MAIN band.

Reverse Function

This function is for monitoring the transmission frequency instead of reception frequency in repeater operation. This technique is commonly used to check if it is possible to communicate without using repeater by monitoring the accessing station's signal strength.

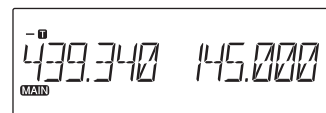

Auto repeater setting

1. **Set SHIFT first. Press FUNC key then press MW key while [FUNC] appears on display.**

[] icon illuminates on the display to indicate that the reverse function is activated and the squelch opens.

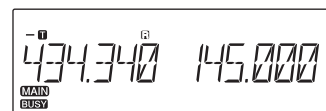

2. **Pressing any key on the front panel will cancel the operation.**

IMPORTANT The Reverse function only operates on the MAIN band. Without SHIFT setting Monitor function will operate instead of Reverse function.

 **NOTE** Rotate squelch knob to monitor repeater's down link.

To Transmit

1. **Set the transmission band to the MAIN side.**
2. **Be sure that you are authorized to operate on the selected frequency. Check the system and monitor the frequency to make sure that you are not going to disturb any ongoing communications.**
3. **Press the PTT key on the microphone.**
The TX lamp (red) illuminates to show the unit is transmitting.

4. **Speak into the microphone in a normal tone while keeping the PTT key pressed.**
Hold the microphone approximately 5cm away from your mouth. Speaking too close or too loud may result in poor transmitted audio. Adjust microphone gain in set mode (Menu 03)

TX lamp

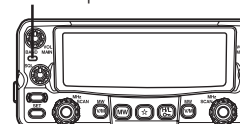

5. **Releasing the PTT key will complete the transmission and the unit will return to the receive mode.**



Pressing the DOWN key together with the PTT key will transmit the CALL tone signal. DR-735T(2) will transmit the Tone Burst signal.

IMPORTANT

If you press the PTT key while out of the transmission frequency range, the [OFF] icon will appear on the display and no transmission will occur.

Selecting Transmission Power

1. **Press H/L key. The transmission power switches from high to middle to low and then low to high.**

At middle power, the [M], and at low power, the [L] illuminates. Nothing appears on the display at high power. The default is high power.

The RF meter shows 119 when transmitting at low power, and 11315 at middle power, and 116151719 at high power.

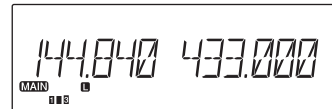

at low power

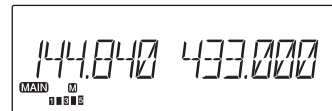

at middle power

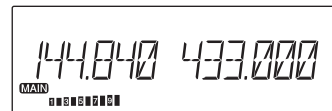

at high power

Transmission Power	VHF	UHF
HI	50W	50W
MID	20W	20W

IMPORTANT

- The output power level cannot be changed during transmission.
- The output power level cannot be changed during scanning.



M power output level is adjustable in set mode (P.54); however RF meter will not change.

Set mode

IMPORTANT

Please read the following pages thoroughly prior to changing any parameters. The parameters in set mode cannot be set without entering the set mode. By entering the set mode, some of the radio's operating parameters can be changed to suit your application. The following is the selectable parameters menu.

A list of setting mode parameters

Copy or cut the following list of the setting mode parameters for your convenience.

Menu	Default Display	Function	Default Value
01	AUTO AUTO	Channel Steps setting	AUTO AUTO
02	AUTO AUTO	Operating mode selection	AUTO AUTO
03	MCGAIN 0dB	Microphone gain Adjusting	0dB
04	BUSY BUSY	Scan type selection	BUSY BUSY
05	SKIP SKIP	Memory cancel mode selection	SKIP SKIP
06	BEEP 2	Beep level selection	2
07	VFO - BP ON	Incoming call display...	ON
08	BEL - OF BEL - OF	Incoming call display	OFF OFF
09	CLMODE ALL	Color mode function selection	ALL
10	SB CL0 SB CL0	Illumination color switching during the waiting time	CL0 CL0
11	RX CL0 RX CL0	Illumination color switching when receiving signal	CL0 CL0
12	TX CL0 TX CL0	Illumination color switching when transmitting	CL0 CL0
13	DIMMER 10	Dimmer	10
14	LAMP OFF	Back light timer	OFF
15	CN TRST 3	Contrast setting	3
16	ATT - OF ATT - OF	Attenuator selecting	OFF OFF
17	MPRTCT OFF	Memory protection	OFF
18	SUBPTT OFF	Sub PTT allocation function	OFF
19	KEY 2	Key push and hold time selecting	2
20	AUTRPT ON	Auto repeater	ON
21	RESTOR OFF	Restore function	OFF

To use the set mode parameters setting mode

1. **Press and hold FUNC key to enter the Set mode. Menu number and parameter will appear on the display.**
2. **Select a menu by pressing left dial knob to decrease menu number or right dial knob to increase menu number, or UP/DOWN keys on the microphone. Push and hold dial for parameters slide show.**
3. **Rotate the dial to change settings.**
Rotate left dial to change parameters on left side and right dial for right side.
4. **Pressing dial or UP/DOWN keys on the microphone will complete the setting and enter the next menu.**
5. **Pressing any key other than the dial knob or the UP/DOWN keys will complete the setting and the unit will exit the parameter setting mode.**

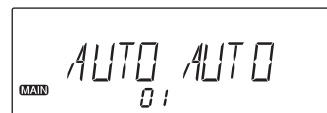

Default display

IMPORTANT Some parameters are assigned to only left or right band and some parameters are not changeable. For details please refer to explanation for each menu.

Set mode menu

Menu 01. Channel Steps setting

This is to select the channel step to be used in the VFO mode. Refer to the P.21 for the sequence of the actual steps and how they are displayed.

Menu 02. Operating mode selection

Operating modes are determined by the modulation of the radio signals. The transceiver has total 5 operating modes (AUTO, FM, NFM, AM, NAM modes). The mode selection is stored independently for each band and memory channel. Typically, AM mode is used for the air band (118–136.995 MHz), and receive is only available.

1. **Press and hold FUNC key to enter the parameter set mode. Press dial to select menu 02. Factory default setting is [Auto].**
2. **Rotate the dial to select FM, NFM, AM or NAM. When NFM or NAM selected Nar will appear on the display.**
3. **Pressing any key other than the dial knob or the UP/DOWN keys will complete the setting and the unit will exit the parameter setting mode.**

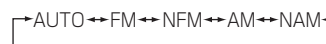
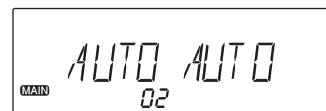

Menu 03. Microphone gain Adjusting

1. **Press and hold FUNC key to enter the parameter set mode. Press dial to select menu 03. Factory default setting is [0dB]. This setting is individual regardless of the band or VFO.**
2. **Rotate the right dial to select a value between -23dB to +23dB. Selecting (-) will decrease and (+) will increase microphone's gain. Also microphone gain can be adjusted during transmission.**

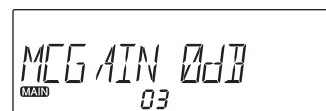

- Pressing any key other than the dial knob or the UP/DOWN keys will complete the setting and the unit will exit the parameter setting mode.

IMPORTANT Pressing PTT switch will not exit the set mode setting.

Menu 04. Scan type selection

This is to select the scan resume condition. The BUSY setting resumes scanning when received signal is gone and TIME setting allows the radio to resume scanning after 5, 10, 20,30 or 60 seconds. This parameter can be selected for both left and right sides in VFO mode and cannot be selected for each band.

- Press and hold FUNC key to enter the parameter set mode. Press dial to select menu 04. Factory default setting is [BUSY].
- By rotating the dial, the display changes as shown and the scan type will be changed.
- Select a desired item.
- Pressing any key other than the dial knob or the UP/DOWN keys will complete the setting and the unit will exit the parameter setting mode.

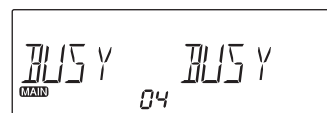

Menu 05. Memory scan mode selection

Use this function to select memory scan conditions. (P.59)

This parameter can be selected for both left and right sides in VFO mode and cannot be selected for each band.

- Press and hold FUNC key to enter the parameter set mode. Press dial to select menu 05. Factory default setting is [SKIP].

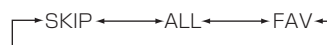
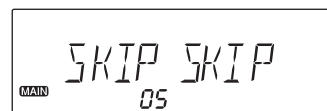

2. **Rotate the dial to select a desired item.**
SKIP : Skips unwanted channels that inconveniently stop scanning.
ALL : Repeatedly scans all frequencies over the entire band regardless of the SKIP or FAV channels.
FAV : Scans only favorite channels.
3. **Pressing any key other than the dial knob or the UP/DOWN keys will complete the setting and the unit will exit the parameter setting mode.**

Menu 06. Beep level selection

This is to change the volume of a beep sound during operation.

1. **Press and hold FUNC key to enter the parameter set mode. Press dial to select menu 06. Factory default setting is [2].**
2. **By rotating the right dial, the display changes as shown and the volume of the beep sound will be changed. This setting is individual regardless of the band or VFO.**
3. **Pressing any key other than the dial knob or the UP/DOWN keys will complete the setting and the unit will exit the parameter setting mode.**

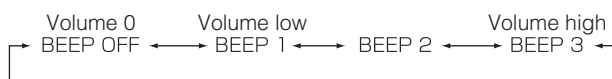
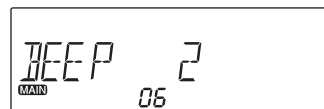

Menu 07. VFO Beep selection

1. Press and hold FUNC key to enter the parameter set mode. Press dial to select menu 07. Factory default setting is [OFF].
2. Rotate the right dial to select a desired item. This setting is individual regardless of the band or VFO.
3. Pressing any key other than the dial knob or the UP/DOWN keys will complete the setting and the unit will exit the parameter setting mode.

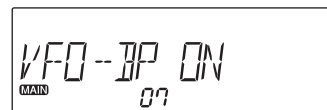

Menu 08. Incoming call selection (Bell)

Incoming call function informs you that you are being called by sounding a bell, and flashing the bell icon on the display.

1. Press and hold FUNC key to enter the parameter set mode. Press dial to select menu 08. Factory default setting is [OFF]. This parameter can be selected for both left and right sides in VFO mode and cannot be selected for each band.
2. By rotating the dial, the display changes as shown and the bell function setting is changed.
3. Pressing any key other than the dial knob or the UP/DOWN keys will complete the setting and the unit will exit the parameter setting mode.

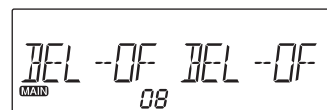

When bell is on:

- Bell icon appears on the display.
- When squelch becomes open, bell icon will flash and beep sound will be heard.
- No beep sound during communications.

Menu 09. Color mode selection

This is the mode to select color mode for various conditions.

1. **Press and hold FUNC key to enter the parameter set mode. Press dial to select menu 09.**

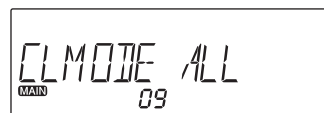

2. **By rotating the right dial, the display changes as shown and the color mode function selection is changed.**

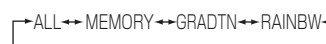

3. **Pressing any key other than the dial knob or the UP/DOWN keys will complete the setting and the unit will exit the parameter setting mode.**

ALL : The color on the left and right sides of the display can be adjusted regardless of the main band, sub band, VFO or memory channels. This is to set color on the left and right side for each waiting, transmitting and receiving conditions. (Green, Yellow and Purple on the left side and Blue, Red and White on the right side regardless of the band)

MEMORY : Select one color for VHF and another color for UHF regardless of the left or right side of display. 6 colors are assigned for 3 bands, left and right sides. Also each memory channel can be programmed for these colors.

GRADTN : Gradation mode. Color on the display changes automatically.

RAINBW : Rainbow colors will move from left to right.



GRADTN and RAINBW mods are fixed and not available for setting or memory channel.

Menu 10. Illumination color selection during the waiting time

1. Press and hold FUNC key to enter the parameter set mode. Press dial to select menu 10.

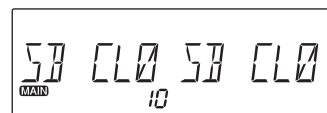

2. By rotating the dial, the display changes as shown and the illumination color selection during the waiting time is changed.

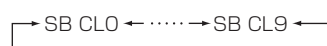

3. Pressing any key other than the dial knob or the UP/DOWN keys will complete the setting and the unit will exit the parameter setting mode.

CL0: White	CL5: Purple
CL1: Red	CL6: Light Blue
CL2: Green	CL7: Orange
CL3: Blue	CL8: Pink
CL4: Yellow	CL9: Light Green

Menu 11. Illumination color selection during receiving signal

1. Press and hold FUNC key to enter the parameter set mode. Press dial to select menu 11.

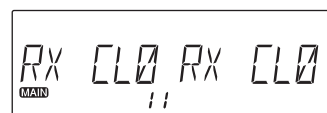

2. By rotating the dial, the display changes as shown and the illumination color selection during receiving signal is changed.

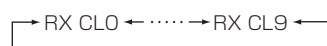

3. Pressing any key other than the dial knob or the UP/DOWN keys will complete the setting and the unit will exit the parameter setting mode.

CL0: White	CL5: Purple
CL1: Red	CL6: Light Blue
CL2: Green	CL7: Orange
CL3: Blue	CL8: Pink
CL4: Yellow	CL9: Light Green

Menu 12. Illumination color selection during transmitting

1. Press and hold FUNC key to enter the parameter set mode. Press dial to select menu 12.

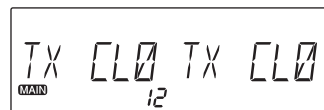

2. By rotating the dial, the display changes as shown and the illumination color selection during transmitting is changed.

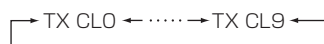

3. Pressing any key other than the dial knob or the UP/DOWN keys will complete the setting and the unit will exit the parameter setting mode.

CL0: White	CL5: Purple
CL1: Red	CL6: Light Blue
CL2: Green	CL7: Orange
CL3: Blue	CL8: Pink
CL4: Yellow	CL9: Light Green

Menu 13. Dimmer

1. Press and hold FUNC key to enter the parameter set mode. Press dial to select menu 13.

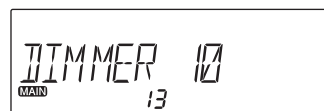

2. By rotating the right dial, the display changes as shown and the dimmer is changed.

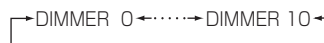

3. Pressing any key other than the dial knob or the UP/DOWN keys will complete the setting and the unit will exit the parameter setting mode.

Menu 14. Back light timer

This is back light timer setting when radio is operated refers to dimmer setting on menu 13.

1. **Press and hold FUNC key to enter the parameter set mode. Press dial to select menu 14.**

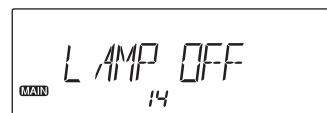

2. **By rotating the right dial, the display changes as shown and the back light timer is changed.**
3. **Pressing any key other than the dial knob or the UP/DOWN keys will complete the setting and the unit will exit the parameter setting mode.**



NOTE

Use this setting when dimmer is set on OFF to have backlight only when radio is operated.

Menu 15. Contrast setting

1. **Press and hold FUNC key to enter the parameter set mode. Press dial to select menu 15. Factory default setting is [3].**

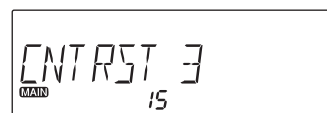

2. **By rotating the right dial, the display changes as shown and the contrast setting is changed. This setting is individual regardless of the band or VFO.**
3. **Pressing any key other than the dial knob or the UP/DOWN keys will complete the setting and the unit will exit the parameter setting mode.**



NOTE

contrast setting has a little effect on some display colors.

Menu 16. Attenuator selecting

The attenuator prevents distortion of a desired signal by very strong RF signals near the desired frequency or when very strong electric fields, such as from a broadcasting station, are present at your location.

1. **Press and hold FUNC key to enter the parameter set mode. Press dial to select menu 16.**
2. **By rotating the dial, the display changes as shown and the Attenuator selecting is changed. Attenuator can be selected for left and right sides and VFO mode but cannot be selected for each band.**
3. **Pressing any key other than the dial knob or the UP/DOWN keys will complete the setting and the unit will exit the parameter setting mode.**



- OFF : Attenuator function is disabled.
- SQ : The transceiver has an RF attenuator related to the squelch level setting. Approx. 10dB attenuation is obtained at maximum setting. The squelch attenuator allows you to set the minimum signal level needed to open the squelch.
- ON : 10dB attenuation is activated on all bands. When attenuator is ON, ATT appears on the display.

Menu 17. Memory protection

This is to prevent important data from being deleted or rewritten accidentally.

1. **Press and hold FUNC key to enter the parameter set mode. Press dial to select menu 17. Factory default setting is [OFF].**
2. **Rotate the right dial to select ON or OFF. This setting is individual regardless of the band or VFO.**
3. **Pressing any key other than the dial knob or the UP/DOWN keys will complete the setting and the unit will exit the parameter setting mode.**





Memory reset (P.73) will delete memory channels data even when memory protection is set ON.

Channel's data can be changed temporarily even when memory protection is set ON; however change will not restore.

Menu 18. Sub PTT allocation function

This is to allocate desired function to the sub PTT switch on EMS-79 microphone.

1. **Press and hold FUNC key to enter the parameter set mode. Press dial to select menu 18.**



2. **By rotating the right dial, the display changes as shown and the sub PTT allocation function is changed.**
3. **Pressing any key other than the dial knob or the UP/DOWN keys will complete the setting and the unit will exit the parameter setting mode.**

OFF : deactivated.

SUB TX : To transmit on the SUB band.

MID TX : To transmit same as MAIN band with MID output power.

LOW TX : To transmit same as MAIN band with LOW output power.

MAIN TX : To transmit same as main PTT switch.

M MONI : To monitor MAIN band.

M BAND : To switch MAIN band.

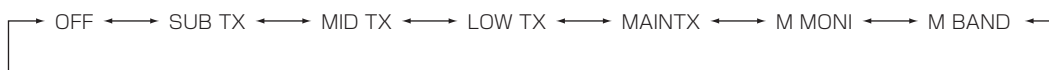

Menu 19. Key push and hold time selecting

This is to change the time for push and holding key for switching band, scan, set mode, key lock, CALL, recalling channel, programming memory in easy mode, etc.

1. **Press and hold FUNC key to enter the parameter set mode. Press dial to select menu 19. Factory default setting is [2] seconds.**
2. **By rotating the right dial, the display changes and the key push and hold time will be changed. This setting is individual regardless of the band or VFO.**
3. **Pressing any key other than the dial knob or the UP/DOWN keys will complete the setting and the unit will exit the parameter setting mode.**

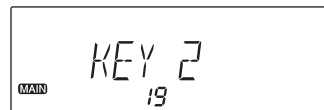

Menu 20. Auto repeater

The USA and Korean versions automatically use standard repeater settings (duplex ON/OFF, duplex direction, tone encoder ON/OFF) when the operating frequency falls within or outside of the general repeater output frequency range. The offset and repeater tone frequencies are not changed by the auto repeater function. Reset these frequencies, if necessary.

1. **Press and hold FUNC key to enter the parameter set mode. Press dial to select menu 20.**
2. **By rotating the right dial, the Auto repeater setting will be changed.**
3. **Pressing any key other than the dial knob or the UP/DOWN keys will complete the setting and the unit will exit the parameter setting mode.**

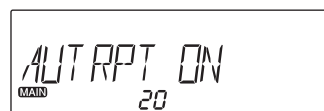

Use VFO auto program to customize auto repeater setting (See page 57)

Menu 21. Restore setting

This is to restore set mode settings. This function is useful to restore settings after resetting the radio. After Adjusting parameters in set mode use this function to restore the settings.

IMPORTANT Color setting and some other setting out of set mode cannot be restored.

1. Press and hold FUNC key to enter the parameter set mode. Press dial to select menu 21. Factory default setting is [OFF].

The LCD display shows the text "RESTOR OFF" in a large font. Below it, in a smaller font, is "MAIN" on the left and "21" on the right.

2. Rotate the right dial to select SAVE and then press and hold FUNC key until hearing the beep.

The LCD display shows the text "RESTOR SAVE" in a large font. Below it, in a smaller font, is "MAIN" on the left and "21" on the right.

3. Pressing any key other than the dial knob or the UP/DOWN keys will complete the setting and the unit will exit the parameter setting mode.

The LCD display shows the text "RESTOR YES" in a large font. Below it, in a smaller font, is "MAIN" on the left and "21" on the right.

4. To recall restored data, repeat above sequence and select YES, then press and hold FUNC key until hearing the beep.

The LCD display shows the text "RESTOR DELETE" in a large font. Below it, in a smaller font, is "MAIN" on the left and "21" on the right.

5. Reset function will not delete restored setting data. To delete repeat 1 and select DELET and then press and hold FUNC key until hearing the beep.

IMPORTANT Settings in set mode can be restored even after doing all reset; however memory channels cannot be restored after all reset.

Useful functions

Single-band mode

This is to use the unit as a single-band transceiver only for VHF or UHF, by eliminating the display on the one side.

1. **Press FUNC key and while [FUNC] appears on the display press VOL knob for desired side. Eliminated band will not operate.**
2. **To return repeat above sequence.**



VFO Auto-program Setting function

This is to program various automatic setting in a certain frequency range in the VFO mode. It is useful for quick repeater access.

1. **Program the lower edge frequency of the desired range as well as other parameters such as repeater shift, CTCSS tone into the APL channel in the memory mode. Programmable items are frequency, shift direction, offset frequency, tone ENC frequency and its setting, tone DEC frequency and its setting, DCS code and its setting, and DCSDEC setting. Press V/M key to complete this process.**
2. **As above, program the higher edge frequency in the APH channel of the memory. Disregard other settings such as CTCSS tones or repeater shift. APH frequency cannot be smaller than APL frequency.**
3. **Disable tone and shift for step1 in the VFO mode and confirm the frequency range between APL and APH. Temporary setting change is possible between APL and APH, but once the frequency is changed by rotating the dial, all the preset values in APL will be restored.**

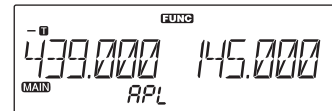

When 439.000MHz 88.5Hz
ENC-5.000MHz shift is set in AL

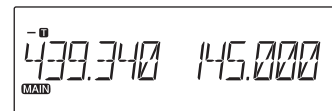
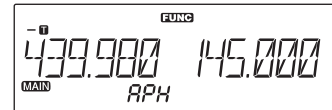

Shows an example within
VFO auto-program setting

- To disable this function, delete the APL memory channel data.**

IMPORTANT Shift, offset, CTCSS and DCS functions cannot be changed during VFO auto program operation.

Scan Function

Use this function to automatically search for signals. In the set mode, chose TIMER mode or the BUSY mode to determine the desired resuming condition. If the CTCSS (TSQ) squelch or DCS squelch is set, the audio can be heard only when the tone / code matched the incoming signal. Otherwise, scanning stops but no audio will be heard. The direction of scan, upward or downward, can be changed during the scan by rotating dial or pressing UP/DOWN keys on the microphone.

■ Automatic Band Exchange Function (A BX)

This function automatically selects whichever band is active, hearing a signal, as the main band. For example, if VHF has been selected as the main band the ABX function will switch automatically to the UHF band if it becomes active and VHF is not receiving a signal. UHF will remain in the main band as long as it hears a signal then will switch back to the VHF band whether or not it is active, likewise, if UHF is the main band ABX automatically switches to VHF if it becomes active while UHF is quiet. This function is built in the radio and cannot be cancelled.

VFO Scan

Scan all VFO channels in regard to the preset tuning step.

- Enter the VFO mode for desired band.**
- Press and hold dial until scanning started or press UP (to go upward) or Down (to go downward) key for more than 1 second but less than 2 seconds. The scan starts and S icon flashes on the display. It stops at the frequency where an incoming signal is detected, and resumes the scan according to the resume setting.**
- Press any key (other than UP/DOWN keys) to exit.**

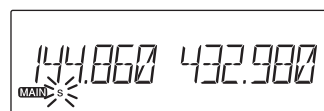

NOTE

By pressing the UP/DOWN keys for more than 2 seconds the frequency changes as long as the key is pressed.

Memory Scan

1. Enter Memory mode for desired band.
2. Sequence is same as in VFO scan. Use UP/DOWN keys for Commands.

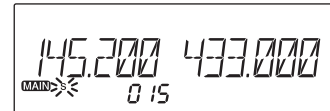

Dual Memory Scan

1. Enter the dual memory mode.
2. Sequence is same as in VFO scan. Use UP/DOWN keys for Commands.

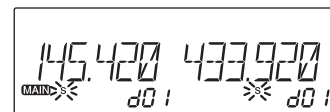

Skip and favorite channels setting

A memory channel set as skip-channel will be excluded from scanning during memory scan. This designation can be set even after the memory is programmed.

Press the FUNC key in the memory mode, and then press the V/M key while the [FUNC] icon is displayed. Select SKIP or favorite (♥) channel by rotating the dial. A memory channel with skip or favorite setting will have the flashing SKIP or ♥ icon on the display. Press dial knob to complete the process.

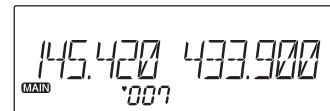
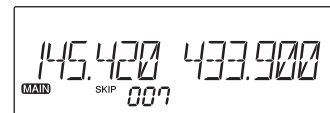

3. To cancel the skip or favorite channel setting, repeat the step 1.
4. Select skip or favorite channels in set mode menu.05 and then start scanning.

Program Scan

This is a type of VFO scan, which is done by setting the frequency range of the VFO into the POA and POB channels, it only scans between those frequencies. Each band can be set for 5 pairs. This program scan will operate under VFO setting, regardless of memory setting for step or POA/B memory setting.

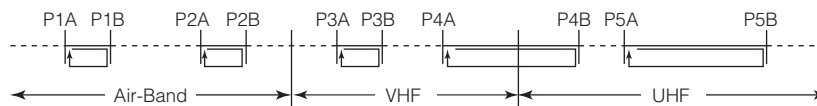

1. **Enter the VFO mode and set the POA and POB frequencies into the designated memory channels. Refer to Memory setting for the proper sequence.**
2. **Return to the VFO mode by pressing V/M key. Set the VFO to the frequency within the range to be program-scanned.**
3. **Press the dial knob after pressing FUNC key while [FUNC] appears on the display. [PS] will appear on the display.**
4. **Rotate the dial or UP/DOWN keys on the microphone to select pair number. Press the dial to start scanning.**
5. **Press any key (other than the UP/DOWN keys) to exit.**

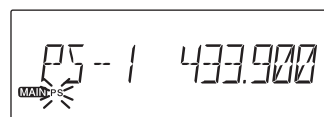

Program Scan is going

Priority Scan

This function allows 5 seconds scan of the user selected priority frequency and other frequency in the VFO or memory modes. Scan will stop for 0.5 seconds when signal received on main frequency and 2 seconds when signal received on priority frequency.

1. **Use the cloning software to program frequency. For details please refer to cloning software instruction manual.**
2. **To start priority scanning, press dial knob while pressing FUNC key. To stop scanning press any key on desired side or press PTT switch. [S] icon will be disappeared.**

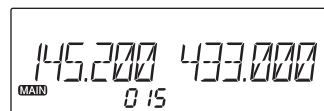

Tone Scan

This function automatically searches for the CTCSS tone an incoming signal might carry. This feature is useful to search for the encoding tone of a repeater, or to communicate with a station operating in TSQ (CTCSS squelch) mode.

1. **Press FUNC key then repeat pressing ★ key while FUNC appears on the display to enter the CTCSS decode setting mode.**

[T SQL] appears on the display.

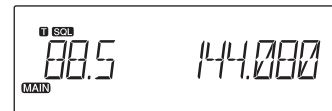

2. **Press and hold dial knob or press the UP/DOWN keys on the microphone for more than 1 second but less than 2 seconds to start scanning. It scans 39 tones in order.**

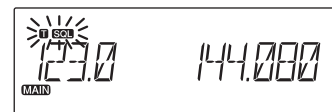

3. **When searching, the [T SQL] icon will flash on the display, tone scanning stops when the matching tone is detected.**
4. **The tone scan won't resume unless the operation in step 2 is repeated. Press any key (other than UP/DOWN keys) to exit.**

DCS Scan

This function automatically searches for the DCS tone an incoming signal might carry. This feature is useful to search for the encoding tone of a repeater, or to communicate with a station operating in DCS (Digital Code Squelch) mode.

1. **Press FUNC key then repeat pressing ★ key while [FUNC] appears on the display to enter the DCS decode setting mode.**
2. **Press the UP/DOWN keys on the microphone for more than 1 second but less than 2 seconds to start scanning. It scans 105 codes in order.**
3. **When searching, the [DCS] icon will flash on the display, DCS scanning stops when the matching code is detected.**
4. **The DCS scan won't resume unless the operation in step 2 is repeated. Press any key (other than UP/DOWN keys) to exit.**

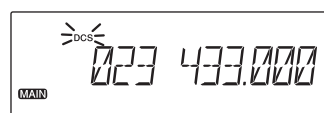

Key-Lock

This will lock the keys to avoid unintentional changes.

1. **Press and hold H/L key.**
The [O-T] icon appears on the display.
2. **To cancel repeat step 1.**
3. **With this function activated, only the following commands can be accessed:**
PTT
H/L key to cancel this function
Squelch and volume
UP/DOWN keys

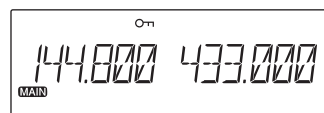

Short-Cut key

Various functions can be assigned to ★ key. There is not a factory default allocation for this key, therefore only beep will be heard by pressing this key.

1. **Enter to set mode and select desired item.**
2. **Press and hold ★ key until beep sound to be heard. When this function is activated ★ appears on the display.**
3. **★ key operates on both VFO and memory modes.**
4. **To cancel repeat step 2.**

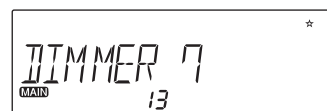

to rewrite ★ key, delete registered data first and then register new item.

RGB color setting

This is to select the display illumination color.

Total 16 colors can be selected. 10 standard colors as CL0 to CL9 and 6 user setting colors as CLA to CLF.

- CL0 to CL9 colors can be changed but color memory channel cannot be deleted.
- CLA to CLF are made by user otherwise will not appear on the display. To delete the color for registered channels, select last channel then press and hold left dial knob.
- Refer to set mode for wait, reception and transmission's color setting.
- RGB color setting can be reset. (P.73)

1. **Press ★ key while pressing and holding FUNC key. The RGB setting appears on the display. Rotate the left dial to change the color and select color memory channel.**
2. **Rotate the right dial to change RGB value.**
Press right dial to select value for R (Red), G (Green) or B (Blue).
3. **Press left dial to save the value. Press any key other than dial knob to complete and exit the process.**
To exit without saving press FUNC key without pressing left dial.

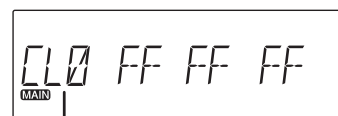

Color memory channel

Selective Communication

Many repeaters require a CTCSS tone or a DCS encode setting as a “key” to access a repeater system, or a receiver using CTCSS or DCS squelch, so called “selective-calling”. Sometimes, CTCSS or DCS decode features are used on the output of a repeater so they can be used to open a squelch. In this mode, regardless of the main squelch status, the audio can be heard ONLY when the matching tone/code signal is received. The combination of CTCSS squelch and DCS function is not available; only one or the other may be used for given frequency.

Tone-squelch (CTCSS) and DCS

1. **Press the FUNC key then press ★ key while [FUNC] appears on the display. The current tone frequency will be displayed. Repeat pressing ★ key to select T/TSQL and DCS change the tone frequency and rotate the dial to change the frequency.**
2. **The numbers (such as 88.5) represent the CTCSS frequency in HZ. When it is displayed with the [T] icon only, the unit transmit the sub-audible tone while the PTT is pressed (encode) and the repeater access is enabled (assuming the repeater is using 88.5).**
3. **Press the same key again so that the [T SQL] icon shows up on the display. This is the CTCSS decode frequency. This enables CTCSS squelch (or Tone Squelch, TSQL).**
4. **Press it again so that the 3-digit number and [DCS] icon is displayed, and it enables DCS encoding and decoding.**

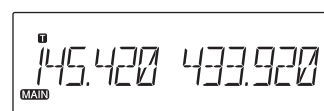

トーンエンコーダーのみ設定時

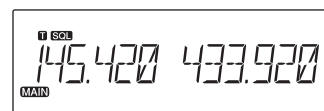

トーンスケルチ設定時

For 2-4, rotate the dial or press the UP/DOWN keys to change the tone or the code. Press any key (other than ★, or UP/DOWN keys on the display) to exit the setting and return to the original status. The [T], [T SQL] or [DCS] icon will remain on the display to show the current status. To cancel, simply repeat the step 1 and select OFF then press any key (other than ★, or UP/DOWN keys on the display) to exit .

The CTCSS encoding and decoding frequencies maybe set differently. The encode setting frequency automatically relates to the decode setting, but the decode setting does not affect encoding. The standard sets of 39 different CTCSS tones are available as shown on the chart below. DCS encode/decode cannot be separated and selectable from 105 codes as shown below.

CTCSS chart (Hz):

67.0	69.3	71.9	74.4	77.0	79.7	82.5	85.4
88.5	91.5	94.8	97.4	100.0	103.5	107.2	110.9
114.8	118.8	123.0	127.3	131.8	136.5	141.3	146.2
151.4	156.7	162.2	167.9	173.8	179.9	186.2	192.8
203.5	210.7	218.1	225.7	233.6	241.8	250.3	

DCS chart:

023	025	026	031	032	036	043	047	051	053	054	065
071	072	073	074	114	115	116	122	125	131	132	134
143	145	152	155	156	162	165	172	174	205	212	223
225	226	243	244	245	246	251	252	255	261	263	265
266	271	274	306	311	315	325	331	332	343	346	351
356	364	365	371	411	412	413	423	431	432	445	446
452	454	455	462	464	465	466	503	506	516	523	526
532	546	565	606	612	624	627	631	632	645	654	662
664	703	712	723	731	732	734	743	754			

Auto-dialer

This function is used to transmit a memorized DTMF code, such as a telephone number, up to 16 (0 to 9/ABCD#*-) digits.

To Program the Auto-dialer:

1. **Press and hold FUNC key then press MW key.**
2. **Rotate left dial or press UP/DOWN keys on the microphone to select channel number.**
3. **Rotate right dial to select code, push dial for next digit or MW key for previous digit. To delete the code press and hold dial.**
4. **Press any key other than PWR, dial knob or V/M to complete and exit.**

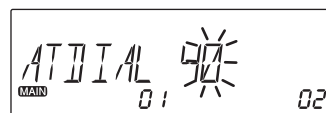
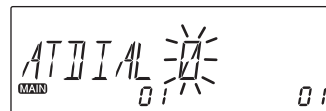

Transmitting the stored Auto-dialer number

1. **Select Auto-dialer channel.**
Press and hold FUNC key then press MW key. Rotate left dial or UP/DOWN keys to select channel.
2. **While pressing and holding PTT switch, press UP key.**
DTMF code for selected channel will transmit (up to 16 digits) and DTMF code sound will be heard.

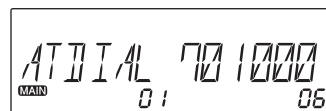

Digital voice communication

By installing an optional digital unit EJ-47U, digital voice communication becomes possible.

1. **Install EJ-47U to the connector of the unit.**
2. **Press the FUNC key, and then press the H/L key while the [FUNC] icon is displayed.**
 - [] appears on the display.
 - Digital voice communication activated only on the right side band.

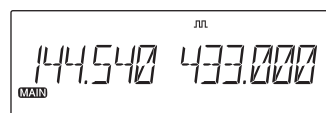

When digital setting made

3. Press the FUNC key or the PTT key to enter the digital communication mode. Repeat step 2 to exit and return to the analogue FM mode.
4. To cancel the digital communication mode, repeat step 2.

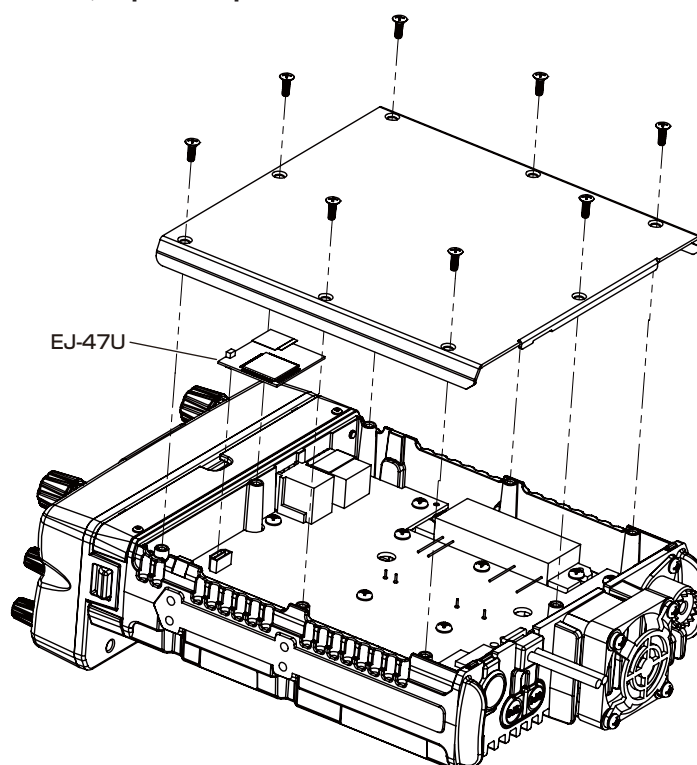

When activating this setting, a code is displayed and switched by rotating the dial. But it does not affect the function EJ-47U. Please disregard this setting sequence. Digital voice operation on certain amateur radio frequencies may be prohibited, restricted or subject to a special station license.

IMPORTANT Please be sure to consult with your local authority prior to operating in this mode.

Cable clone function

This feature will copy the programmed data and parameters in the master unit to slave units.

■ Connection

Make a cable using 3.5 mm stereo-mini plugs as shown. Make a master unit by setting and programming it as desired. Turn off both units. Connect the cable between the DATA jacks (SP1) on both master and slave. Turn both radios on after the connection is made.

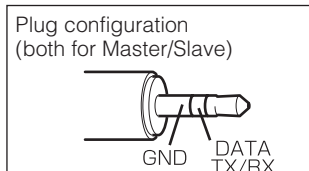

IMPORTANT Be certain to connect cables while the units are turned OFF.

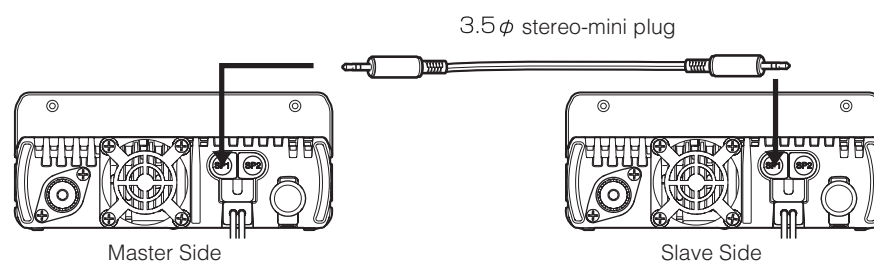

■ Setting on the Master side

1. Press the **FUNC** key and then press **MW** key while **[FUNC]** appears on the display. **[CLONE SD0000]** will be displayed and the radio enters the clone mode.
2. Press **PTT**. **[CLONE SD****]** will be displayed and the master unit start sending data to the slave unit.
**** will change during data transferring.
3. **[CLONE PASS]** will appear on the display when the data has been successfully transmitted.
4. The master radio may stay turned on for the next clone. Turn off the unit to exit from the clone mode.

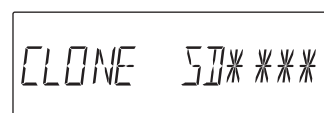
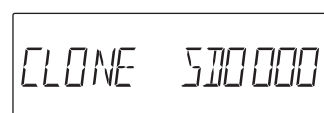

During transmission

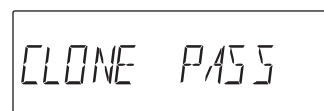

When transmission is finished

■ **Entering a frequency directly**

Frequencies can be entered directly by pressing the numerical keys of the microphone.

- 1. Set the microphone DTMF/REMOTE switch to the REMOTE position.**
- 2. DTMF keys can be used to enter total 6 digits from the digit for 100 MHz to digit for 1 KHz.**

If entered frequency be out of tuning step, closest digit will set.

(Ex.) When setting 144.20 MHz with the turning step set to 20 KHz.

Enter 1 4 4 2 0

After entering the last digit a slightly longer beep is emitted and the entry is completed.

To cancel an entry before it is completed, press the PTT key or C key.

Maintenance / Reference

Reset

Resetting the unit returns all programmed contents to their factory default settings. By using restore function (menu. 21),(P.47)setting can be restored but memory channel data cannot be restored. Use cloning software, interface cable and computer to save and restore memory data.

Normal Reset (Basic Reset)

This is to reset setting for VFO, memory and advanced memory modes.

1. Turn on the radio by pressing PWR key while pressing FUNC key.
2. All segments of the LCD will be displayed and normal reset completed.

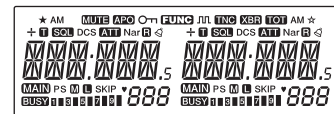

All LCD segments

VFO Reset

This is to reset only VFO mode setting. All setting in set mode and memory data will remain.

1. Turn on the radio by pressing PWR key while pressing left V/M key.
2. All segments of the LCD will be displayed and VFO reset completed.

Memory Reset

This is to reset only memory data. All settings in set mode and VFO frequency will remain.

1. Turn on the radio while pushing right V/M key.
2. All segments of the LCD will be displayed and memory reset completed.

RGB Reset

This is to reset user setting display color (CLA to CLF).

1. Turn on the radio by pressing PWR key while pressing right V/M and ★ key together.
2. All segments of the LCD will be displayed and RGB reset completed.

All Reset

This is to reset radio to factory default setting (except restored data in restore setting). All above reset will be activated.

1. Turn on the radio by pressing PWR key while pressing right MW, H/L and ★ key together.
2. All segments of the LCD will be displayed and All reset completed.

Troubleshooting

Please check the list below before concluding that the transceiver is faulty.

If a problem persists, reset the transceiver. This can sometimes correct erroneous operation.

Problem	Possible Causes	Potential Solutions
Power is on, nothing appears on the display	a. + and – polarities of power connection are reversed. b. Fuse is blown. c. Power supply or DC/DC convertor is not turned on.	a. Correctly connect the red lead and the black lead of the DC power cable provided respectively to the plus and minus terminals. b. Check and solve the problem resulting in blown fuse and replace it with a new one with the same rated capacity. c. Turn on the power supply or DC/DC convertor.
Display is too dim.	Dimmer setting level is low.	Make the dimmer level setting higher.
No sound comes from the speaker. The unit does not receive.	a. The volume knob is rotated too much counter-clockwise. b. Squelch is muted. c. Tone or DCS squelch is active d. PTT key of the microphone is pressed for transmission. e. External speaker is defected.	a. Set the volume knob properly. b. Decreases squelch level. c. Turn tone or DCS squelch off. d. Immediately release PTT switch. e. Remove the jack from the external speaker terminal and check external speaker.
Keys and the dial do not function.	Key-lock function is activated ([LOCK] is on).	Cancel key-lock function.
Rotating the dial will not change memory channel.	a. No memory is programmed. b. The unit is in CALL mode.	a. A. Program memory b. Press V/M key to cancel CALL mode.
Pressing the UP/DOWN key will not change frequencies or memory channels.	a. The unit is in CALL mode. b. Lock switch on the microphone is ON.	a. Press V/M key to cancel CALL mode. b. Turn off the lock switch on the microphone.
PTT key is pressed but transmission does not occur.	a. Microphone terminal is not properly inserted. b. Antenna is not connected. c. [OFF] appears on the display.	a. Properly insert the microphone connection. b. Properly connect the antenna. c. Cancel SHIFT or set within the band. d. Transmit inside transmission range.

■ Noise

- When reception frequencies fall in any one of the formula below, the unit may receive a non-modulated signal.
This is due to the structure of frequencies of this unit and not a malfunction of the unit.
(Reception frequency on the left side VHF band – 21.7MHz) X 3 = UHF reception frequency on the right side)
(Reception frequency on the left side UHF band – 21.7MHz) X 3 – (VHF reception frequency on the right side + 30.85MHz) X 7 = 30.85 MHz
- When reception frequency is 3 times bigger than transmission frequency, transmitted voice will be heard and [FREQ X3] appears on the display.

■ Demonstration mode

This is to set unit for exhibition purpose. Display changes automatically. Demonstration mode can stop temporary for 10 minutes if by rotating dial. To enter activate Key-Lock function then turn off the radio. Turn on radio while pressing MW and H/L key together. Repeat to deactivate the mode.



The transceiver automatically returns to demonstration mode after 10 min. in which no operations are performed.

Specification

General	DR-735T(2)	
Frequency coverage: Transmit	144.000 ~ 145.995MHz 430.000 ~ 439.995MHz	
Frequency coverage: Receive	108.000 ~ 173.995MHz 400.000 ~ 479.995MHz	
Operating mode	F3E	
Antenna impedance	50Ω	
Operating temperature	-10°C ~ +60°C	
Power requirement	DC13.8V±15% (11.7 ~ 15.8V)	
Frequency stability	±2.5ppm	
Current drain	Transmit	Approx. 12.0A
	Receive	Approx. 600mA (Max), Approx. 400mA (Squelched)
Microphone impedance	2kΩ	
Ground method	Negative ground	
Dimensions	140 (W)×FRONT:60 Body:40 (H)×188 (D)mm	
Weight	Approx. 1.3kg	

Transmitter

Output power	50W (HI) 20W (MID) 5W (LOW)
Modulation system	Variable reactance frequency modulation
Maximum frequency deviation	±5kHz (FM), ±2.5kHz (FM)
Spurious emission	-60dB

Receiver

Receiver circuitry	Double superheterodyne
Intermediate frequency	1st:21.7MHz / 2nd:450kHz 1st:30.85MHz/ 2nd:455kHz
Sensitivity (-12dB SINAD)	-14dBu (0.2uV)
Squelch sensitivity	-18dBu (0.1uV)
Selectivity (-6dB)	12kHz
Selectivity (-60dB)	24kHz
Audio output power	2.0W (8Ω, 10% THD)

All specifications are subject to change without notice or obligation.

ALINCO,INC.

Head Office: Yodoyabashi-Dai Building 13th Floor
4-9, 4-Chome, Koraihashi, Chuo-ku, Osaka 541-0043, Japan
Phone: +81-6-7636-2362 Fax: +81-6-6208-3802
<http://www.alinco.com/>
E-mail: export@alinco.co.jp