

(Refer page 27 for how to enter the setting mode.)

Time-Out-Timer

The TOT feature is popular in repeater systems. It prohibits the users from transmitting on the repeater after a certain period of time has elapsed. By setting this function and activating it according to the repeaters' requirement, the radio alerts the user by a beep 5 seconds prior to time-out. When the time is expired, transmitting stops and the transceiver automatically returns to receiving mode. This avoids the repeater going into its TOT mode. Until the PTT is released once and pressed again, the transceiver will not transmit.

1. In this Menu the default display shows TOT-OFF.



2. Rotate the main dial to select time-out time. The display should change as shown. The number followed by TOT is the time-out time in seconds. The TOT feature is selectable up to 450 seconds (7.5 minutes).

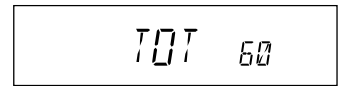

During the setting time of 60 seconds

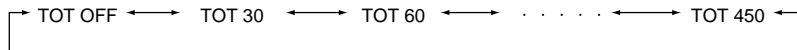

TOT Penalty

When transmission is shut down in the TOT mode, this function prohibits another transmission during a selected TOT penalty period regardless of the PTT key pressed. A beep sounds when the PTT key is pressed during the TOT penalty period. If the PTT is continuously pressed over both TOT and the TOT penalty period, this function will be automatically cancelled.

Setting the TOT penalty time

1. [TOTP OFF] icon appears on the display.

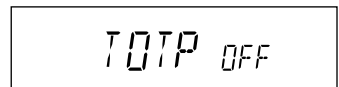

2. By rotating the main dial, the display changes as below and TOT penalty setting is changed. The penalty time can be set up to 15 seconds.

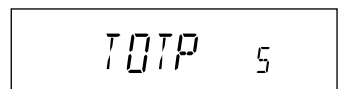

In case the setting time is 5 seconds

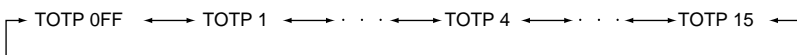

APO-Auto Power OFF

This feature will automatically shut off the transceiver. It is useful for mobile operation to avoid draining the car battery. If there is no activity or use of the radio, it will turn off automatically after 30 minutes followed by a beep sound.

1. Default is APO-OFF.



2. Rotate dial to select APO-ON to activate the function.



During the ON setting

Tone-Burst Frequency

This is to access Tone-Burst repeaters which require a certain pitch of audible tone to activate “sleeping” repeaters. Usually, a repeater system does not require the tone once the repeater is activated.

Tone Burst frequency can be set to ALERT, 1750Hz, 2100Hz, 1000Hz and 1450Hz. (ALERT is an intermittent recalling sound)

1. [ALERT] icon appears on the display.

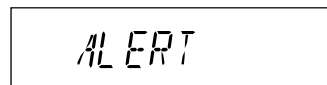

2. By rotating the main dial, the display changes as below and Tone Burst frequency setting is changed.

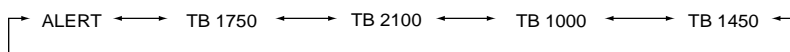

Clock shift

In the unlikely event that CPU clock noise is present on a particular operating frequency programmed into the radio, you can shift the CPU clock frequency to avoid the CPU clock noise, which normally is so weak that it is inaudible even if the radio is tuned exactly to its frequency.

1. [CKSFT OFF] icon appears on the display.

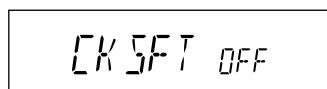

2. By rotating the main dial, the display changes as shown and Clock shift setting is changed.

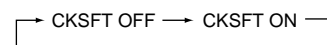

(Refer page 27 for how to enter the setting mode.)

Bell

The bell informs you that you are being called by sounding a bell, and flashing the bell icon on the display.

1. [BELL OFF] icon appears on the display.



2. By rotating the main dial, the display changes as shown and Bell function setting is changed.

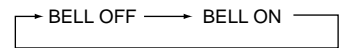

Busy-Channel-Lock-Out (BCLO)

This function prohibits transmission as long as there is a signal on the receiving frequency. The default is BCLO-OFF, which is the off position. By activating this function, the radio transmits only when:

1. No signal is received (BUSY icon is gone) on the receiving frequency.
2. Tone-squelch is opened by the corresponding CTCSS tone of the receiving signal.
3. As above, with DCS code.

Otherwise a beep sounds but the unit does not transmit even when the PTT is pressed.

1. [BCLO OFF] icon appears on the display.



2. By rotating the main dial, the display changes as shown and BCLO setting is changed.

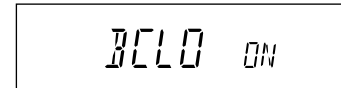
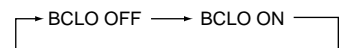

Theft Alarm

(Please refer page 44 for details)

1. [SCR OFF] icon appears on the display.

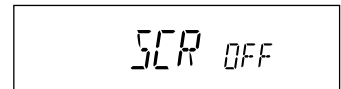

2. By rotating the main dial, the display changes as shown and Theft Alarm is set ON/OFF.

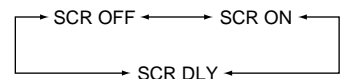

3. When Theft Alarm is set, [*] icon appears on the display.

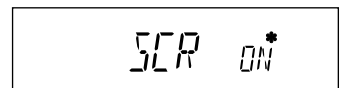

Illumination color setting

This is to select display illumination color.

1. [COLOR 1] icon appears on the display.

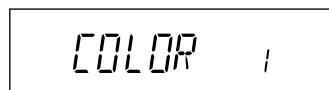

2. By rotating the main dial, the display changes as right and illumination color is changed. COLOR 1 is Amber (Red) illumination. COLOR 2 is Yellow illumination. COLOR 3 is Orange illumination.

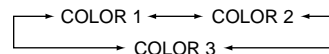

Dimmer

This is to provide better visibility of the display by dimming the display illumination in the dark.

1. [LAMP 4] icon appears on the display.

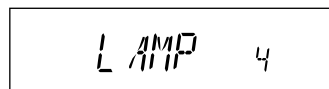

2. By rotating the main dial, the display changes as below and Dimmer setting is changed. It is bright with LAMP 4 and will be darker with 3-2-1.

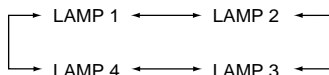

Call sign setting (In packet operation)

This is to register the call sign of your station to transmit in Packet communication mode. 36 characters, A - Z and 0 - 9 are available for registration.

1. The display shows [C] flashing.
2. Rotate the dial to select a character to be programmed.
3. By pressing the BAND key, the character is illuminated and entered. An identical character to the one just entered flashes on the immediate right ready to be entered.
4. Enter with the BAND key (Repeat the same sequence). You can program up to 6 digits.
5. Pressing the CALL key during programming will delete all characters to be programmed.



(Refer page 27 for how to enter the setting mode.)

Transmission speed setting (In packet operation)

This is to set transmission speed at the time of data communication.

1. [HB 1200] icon appears on the display.
2. By rotating the main dial, the display changes as right and setting is changed.
[HB 1200] Transmission speed is set at 1200bps.
[HB 9600] Transmission speed is set at 9600bps.

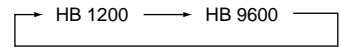
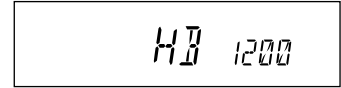

Beacon interval setting (In geolocating communication/A.P.R.S.®)

This is to set a transmission time separation of GPS location data when Geolocating communication is in operation.

1. [BCON 0] icon appears on the display. No transmission is made at BCON 0.
2. By rotating the main dial, the display changes as below and setting is changed.

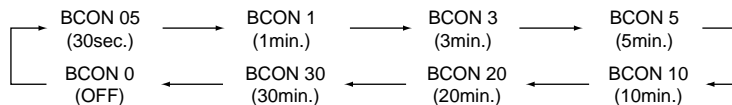
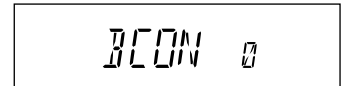

Setting for call sign, transmission speed and beacon interval will be transmitted to TNC unit (EJ-50U) by TNC clone.

Operation of TNC will stay unchanged until TNC clone transmission will be completed.

Useful functions

Reception band switching

This is to switch the receiving band. On VHF side, FM broadcasting can be received.

1. After pressing the FUNC key, press the CALL key while [F] icon is on.
On VHF side, the band switches from 144MHz band to FM broadcasting band.

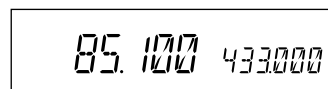

V-V/U-U simultaneous reception

This is to receive the same frequency band simultaneously both on the MAIN band and the SUB band, while in the VFO mode.

1. After pressing the FUNC key, press the BAND key while [F] icon is on.
Display on the SUB band changes to the same frequency band as the MAIN band.
The default frequency of the SUB band is VFO default frequency.
2. To change frequency or setting of the SUB band, switch the SUB band to the MAIN by the BAND key before operation.
3. By pressing the BAND key after pressing the FUNC key again, the display will return to the normal V-U display.
If you switch BAND while having FM broadcasting band on the MAIN side, the display will show [SUB] icon illuminating.
At this time, the MAIN band will be exclusive for reception and not be ready for transmission. When [SUB] icon is on the display, memory programming is not possible either.

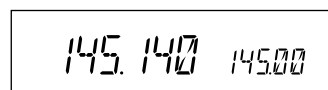

When V-V/U-U is set

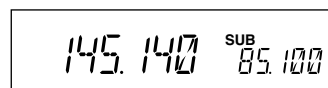

In this case no transmission is possible on the MAIN band

Single-band mode

This is to use the unit just like a single-band transceiver only for VHF or UHF, by erasing display on the SUB side.

1. Press the BAND key while pressing and holding the FUNC key.
The display on the SUB side disappears and its function is temporary suspended.
While in the V-V/U-U mode, the unit will not enter to the single-band mode.



VFO Auto-program setting function

This is to program various automatic settings in a certain frequency range in the VFO mode. It is useful for quick repeater access.

1. Program the lower edge frequency of the desired range as well as other parameters such as repeater shift, CTCSS tone into the [AL] channel in the memory mode (Refer page 19). Programmable items are frequency, shift direction, offset frequency, tone ENC frequency and its setting, tone DEC frequency and its setting, DCSSEN code and its setting, and DESDEC setting.
2. As above program the higher edge frequency in the [AH] channel of the memory. Disregard other settings such as CTCSS tones or repeater shift.
3. In the VFO mode, what have been programmed in the AL memory are automatically set within the frequency band between AL and AH. Temporary setting change is possible between AL and AH, but once frequency is changed by rotating the dial, all the preset values in AL will be restored.

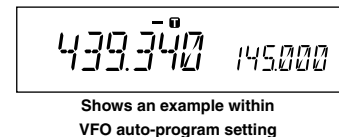
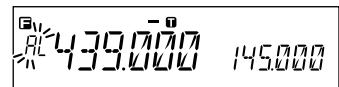
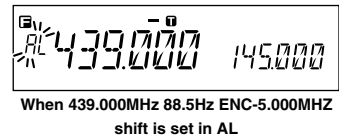

SCANNING FUNCTION

Use this function to automatically search for signals. 6 different scan types are available in the unit. In parameter setting mode, choose Timer mode or Busy mode to determine the desired resuming condition. If the CTCSS(TSQ) squelch or DCS squelch is set, the audio can be heard only when the tone/code matches the incoming signal. Otherwise, scanning stops but no audio will be heard. The direction of scan, upward or downward, can be changed during the scan by rotating the main dial or pressing UP or DOWN keys in the desired direction.

•VFO Scan

Scans all VFO channels in regard to the preset tuning step.

1. Enter VFO mode.
2. Press UP (to go upward) or Down (to go downward) key for more than 1 second but less than 2 seconds.
3. The scan starts. It stops at the frequency where the incoming signal is detected, and resumes the scan according to the resume setting.
4. Press any key (other than UP/DOWN keys) to exit.

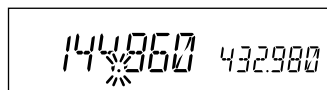

- NOTE:
- By pressing the UP/DOWN key for more than 2 seconds the frequency changes as long as key is pressed.
 - When both MAIN and SUB bands are in the VFO mode (except when in V-V/U-U), you can operate the BAND key even during scanning and simultaneous scanning both for V and U is possible.

•Memory Scan

Scans all memory channels unless Memory skip feature is selected for a given memory.

1. Enter Memory mode.
2. Sequence is the same as in VFO scan. Use UP/DOWN keys for commands.



Range of Memory Scan

Exclusive scanning for VHF/UHF:

If scanning is started somewhere between 00 and 79, scanning is always repeated within this range.

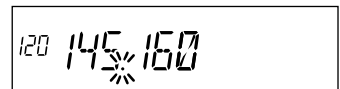

During mixed scanning for V/U

Mixed scanning for V/U:

If scanning is started somewhere between 100 and 139, scanning is always repeated within this range.

•Skip-channel setting

A memory channel set as a skip-channel will be excluded from scanning during Memory Scan, and can be set even after the memory is programmed.

1. Press the FUNC key in the Memory mode, and then press the V/M key while [F] icon is illuminating. Skip setting of a memory channel selected is made.
A memory channel with skip setting will have 1MHz decimal point put off.
2. To cancel skip-channel setting, repeat the step 1.

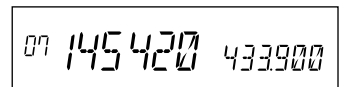

IMPORTANT: CALL, PL, PH, AL, AH and ch.99 are always skipped.

•Program Scan

This is a type of VFO scan, but by setting the frequency range of the VFO into PH and PL channels, it only scans between those frequencies. With setting the PH and PL properly, up to 3 Program scan ranges will be available, which are L-PH, PL-PH and PH-H.

1. Enter the VFO mode and set the PL and PH frequency into the designated memory channels. Refer to Memory setting for the proper sequence.
2. Return to VFO mode by pressing V/M key. Set the VFO to the frequency within the range to be program-scanned.
3. Press MHz key for more than 1 second to start scanning. During this scan mode, a decimal point flashes as shown.
4. Use main dial or UP/DOWN keys to change the direction. Press any key (other than the UP/DOWN keys) to exit.

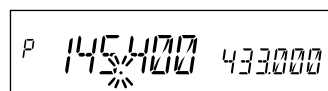
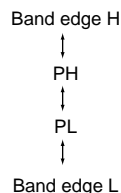

Program Scan is going

•Tone Scan

This function automatically searches for the CTCSS tone an incoming signal might carry. This feature is useful to search the encoding tone of a repeater, or to communicate with a station operating in TSQ (CTCSS squelch) mode.

1. Press TS/DCS key to enter CTCSS decode setting mode.
2. Press UP/DOWN key for more than 1 second but less than 2 seconds to start scanning. It scans 38 tones in order.
3. The decimal point on the tone frequency will flash, and it stops when the matching tone is detected.
4. The scan won't resume until the operation is repeated.
5. Press any key (other than UP/DOWN keys) to exit.

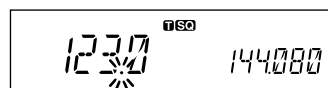
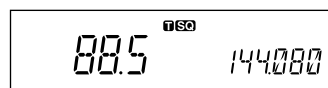

•DCS scan

Same as previous, but for DCS code search.

1. While in the DCS setting, press the UP/DOWN key for more than 1 second but less than 2 seconds to start scanning.
(It scans 105 DCS codes in order.)
 - During scanning, 1 MHz order decimal point will flash.
 - The scan stops when the matching DCS code is detected and reception starts.



IMPORTANT: After scanning is over, it will not resume until another dialing or UP/DOWN key pressing will be made.

2. After scanning is over, pressing any key other than UP/DOWN key will cancel the scan mode.

KEY-LOCK FUNCTION

This will lock the keys to avoid unintentional changes.

1. Press FUNC key and press TS/DCS key while F icon is on the display.
2. The [] icon appears.
3. With this function activated, only the following commands can be accessed:
 - PTT
 - FUNC+TS/DCS to cancel this function
 - Monitor function (to release squelch for weak signal reception)
 - Squelch setting
 - UP/DOWN keys



TONE BURST

This feature is to recall the other party by adding a tone to the transmitting signal.

- While the PTT key and the DOWN key are pressed together, a tone signal is transmitted.
- The default is an alert sound. Transmitted tone can be changed in the Setting mode.
- For DR-620E, 1750Hz tone burst signal is transmitted as the default setting, so that a repeater can be accessed to.

Narrow-band mode

This feature is to prepare for the possible future change of the tuning step.

1. Press the MHz key together with the FUNC key. [Nar] icon illuminates on the display to show the unit is in the Narrow mode.
2. Repeat the same operation to return to the normal mode.

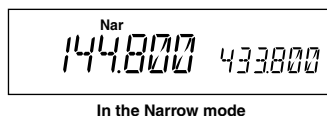

IMPORTANT: In the NARROW mode, the microphone gain and modulation during transmission and the demodulation range during reception will be lower.

AM receiver mode

This mode is to receive AM signals.

1. Press the TS/DCS key while the FUNC key is pressed. [AM] icon illuminates on the display to show the unit is in the AM reception mode.
2. Repeat the same operation to return to the FM mode. Even while AM mode is set, the FM mode will resume for TX even though AM icon remains.

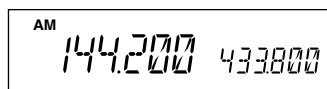

Selective Communication

Many repeaters require a CTCSS tone or a DCS code encode setting as a “key” to access the system, so-called “selective-calling”. Sometimes, CTCSS or DCS decode features are used on the output of a repeater so they can be used as a squelch. In this mode, regardless of the main squelch status, the audio can be heard ONLY when the matching tone/code signal is received. The combination of CTCSS squelch and DCS function is not available; only one or the other may be used for a given frequency.

Tone-squelch (CTCSS) and DCS

1. Press TS/DCS key. The current setting will be displayed with T/SQ/DCS icons and relative frequency/code. Press the same key to select T/SQ/DCS setting.
2. The numbers (such as 88.5) represent the CTCSS frequency in Hz. When it is displayed with the T icon only, the unit transmits the sub-audible tone while the PTT is pressed (encode) and the repeater access is enabled (assuming the repeater is using 88.5).
3. Press the same key again so that the SQ icon shows up on the display. This is the CTCSS decode frequency. This enables CTCSS squelch (or Tone Squelch, TSQ).
4. Press it again so that the 3-digit number and DCS icon is displayed. This is the DCS code, and it enables DCS encoding and decoding.

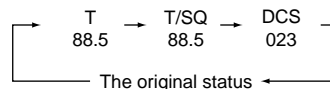

For 2-4, rotate the main dial or press the UP/DOWN keys to change tone or code. Press any key (Except TS/DCS, UP/DOWN keys) to enter the setting and return to original status. The T/SQ/DCS icon will remain on the display to show the current status. To exit, simply use the TS/DCS key and press it until the relative status icon T/TQ/DCS disappears.

The CTCSS encoding and decoding frequencies may be set differently. The encode setting frequency automatically relates to the decode setting, but decode setting does not affect encode. The standard set of 38 different CTCSS tones are available as shown on the chart below. DCS encode/decode cannot be separated and are selectable from 104 codes as shown below and following page.

67.0	71.9	74.4	77.0	79.7	82.5	85.4	88.5
91.5	94.8	97.4	100.0	103.5	107.2	110.9	114.8
118.8	123.0	127.3	131.8	136.5	141.3	146.2	151.4
156.7	162.2	167.9	173.8	179.9	186.2	192.8	203.5
210.7	218.1	225.7	233.6	241.8	250.3		

023	025	026	031	032	036	043	047	051	053	054	065
071	072	073	074	114	115	116	122	125	131	132	134
143	145	152	155	156	162	165	172	174	205	212	223
225	226	243	244	245	246	251	252	255	261	263	265
266	271	274	306	311	315	325	331	332	343	346	351
356	364	365	371	411	412	413	423	431	432	445	446
452	454	455	462	464	465	466	503	506	516	523	526
532	546	565	606	612	624	627	631	632	645	654	662
664	703	712	723	731	732	734	743	754			

DET setting

In case DET mode in DCS operation is preferred, press H/L key while DCS code is displayed in the setting mode. Observe that a decimal point appears then follow the remaining sequence to set the parameter and exit.

DET on DCS function stands for Detect-Only mode. In DCS operation, the TX signal carries digital code such as 001010000 determined by setting the 3-digit code such as 123,124 etc. This stream is modulated with very low sub-audible frequency. The RX side, just like TSQ, detects this stream and determines the squelch operation. This DCS code stream is transmitted all the way through the communication like CTCSS tone (in this case a single continuous tone, instead of digital coded stream).

It is necessary for receiver to correctly and CONTINUOUSLY receive this DCS digital stream to hold the squelch open, otherwise the CPU thinks that the signal is unwanted and it closes the squelch. But due to noise or weak signal strength etc, sometimes it is difficult to continuously receive DCS stream. By activating DET, the receiver opens squelch when the first corresponding DCS stream is received, then thereafter, regardless of the status of DCS codes the DCS squelch remain opened.

Advantage of DET

It enables DCS squelch operation even in poorer condition, opening the squelch only when corresponding DCS coded signal is received.

Disadvantage of DET

When it is activated, and suppose 2 stations are sharing the same channel with using DCS selective-calling technique and transmitting at the same time, after the station A with corresponding DCS is gone, you may still hear the station B although he can't open your DCS squelch by his signal alone.

Digital voice communication (DR-620T only)

By installing an optional digital unit EJ-47U, digital voice communication becomes enabled.

1. Install EJ-47U to the connector CN3 of the unit.
2. Press the FUNC key, and then press the SQL key while [F] icon is illuminating.
[JL] is shown on the display.
3. Press the FUNC key or the PTT key to enter the digital communication mode. Repeat step 2 to exit and return to analog FM mode.
4. To cancel the digital communication mode, press the SQL key while the display shows codes in step 2.

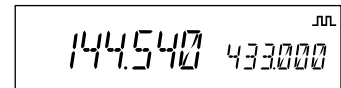

When digital setting is made

IMPORTANT: During setting, code is displayed and switched by rotating the dial, but it does not affect the function of EJ-47U. Please disregard this setting sequence. The digital voice operation within the amateur radio frequency may be prohibited, restricted or subject to special station license. Please be sure to consult with your local authority prior to operate this mode.

Special Functions

THEFT ALARM

This alert uses a beep sound when the unit is about to be removed in an improper manner. This function is useful when the unit is installed in a vehicle.

To connect, set and operate

IMPORTANT: Be sure to connect the power cable directly to a car battery. The power cable of this unit requires voltage at all times to activate this function. For the same reason, ACC ON/OFF feature must be deactivated.

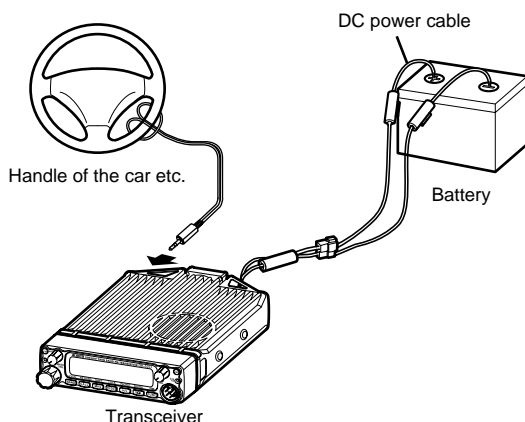

1. Wire the alarm cable (There are 2 ways to configure).

1. Modifying and inserting 3.5 Ø stereo plug for alarm into the SP terminal jack in the back, as the figure shows.

This configuration is recommended for vehicle installation for the easier removal of the cable

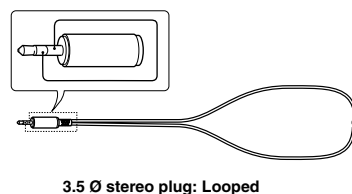

2. Modifying and inserting the provided wiring cable UX1290A into the connector CN10 in the unit.

This configuration is recommended for semi-permanent setting. By selecting this configuration speaker remains active, either internal or external, as configured.

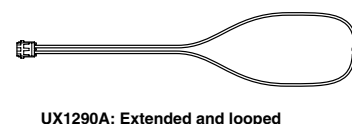

2. Be sure to fix the alarm cable to a steering etc. as the figure shows.

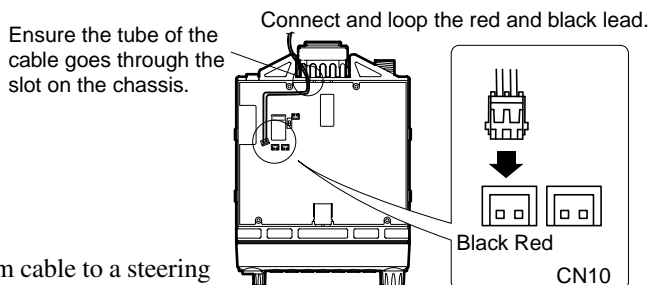

3. Set SCR-ON in the setting mode. The [*] icon will appear on the display.
4. Turn OFF the unit.
Alarm function is activated, the display will turn off and TX display lamp will start illuminating.
5. To deactivate, turn ON the unit and set SCR-OFF in the setting mode.

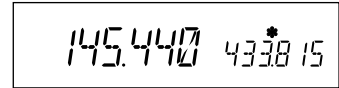

TX display lamp

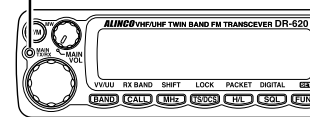

- IMPORTANT:**
- To activate the function, be sure to switch OFF the power after having connected the cable for alarm. (Connecting it after the power is off may activate the alarm)
 - The alarm will not be active unless the PWR switch is turned off.
 - The alarm function will not operate if the power is OFF in the ACC power supply control function.
 - The alarm cable A/B provided with DR-135/435 are not compatible with this unit.

How the alarm operates

When the alarm cable is removed from the port or cut without using the proper sequence, the alarm sounds for 10 minutes. During the alarm, the unit goes to receive on memory channel 99, according to its pre-programmed setting (TSQ/DCS accepted).

To cancel alarm setting while the alarm is in work

1. When a signal is received on ch.99 the alarm stops. If ch.99 is empty the unit stays monitoring the Main-VFO frequency. Turning on the unit with SQL key pressed also cancels the alarm.
2. When the power is OFF again, the alarm setting will resume.

NOTE: The alarm feature on DR-620TA version functions in a slightly different manner.

1. When the alarm starts, the unit alternates between transmit and receive on ch.99 every 5 seconds for 5 minutes.
2. Setting and operation of the function are the same as other versions.
This feature allows you to monitor and to control the alarm from a remote place by using ch.99 on memory mode.

Setting alarm starting time

Choose this operation when a delay period is desired.

1. Enter the Parameter setting mode as described previously and select SCR-DLY. Follow the previous instruction to set.
2. Turn off the unit. Display will disappear but the LCD illumination stays on. After 20 seconds TX LED lights up, illumination dims, and alarm functions. The system won't work during the 20 second "DELAY" period.
3. The alarm sounds under the same condition as described previously. There is a 20 second delay until the alarm sounds. During the 20 second period, only the display illumination is lit. Turn ON the unit with the SQL key pressed during "DELAY" period to cancel the alarm function.

TX display lamp

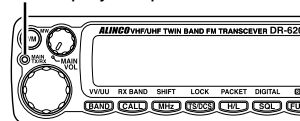

IMPORTANT: Please set the parameters at SCR-OFF during normal operation.

NOTE: Please use a sticker provided indicating installation of the theft alarm device.

Setting on the Master side

1. Press CALL key with FUNK key pressed. CLONE will be displayed and the radio enters the clone mode.
2. Press PTT. SD*** will be displayed and it starts sending the data into the slave unit.
3. [PASS] will appear on the display when the data is successfully transmitted.
4. The master radio may stay turned on for the next clone. Turn off the unit to exit from the clone mode.

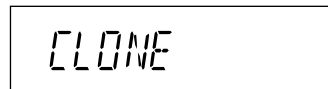

CLONE

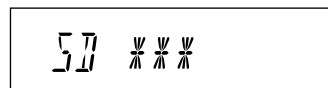

SD***

During transmission

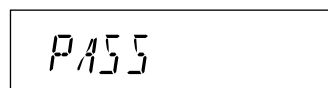

PASS

When transmission is finished

If the data is not successfully transmitted, turn off both units, make sure the cable connection is correct and repeat the entire operation from the beginning.

IMPORTANT: Never pull off the cable while the data is transmitted in clone mode.

Packet Communication

Packet communication is a high-speed data communication system transmitting a package of data by keyboard operation of a personal computer. The use of Digi-peaters (relay stations) offers communications with DX stations (distant stations). For packet communication, a personal computer and an optional EJ-50U (TNC unit) are required other than this unit.

EJ-50U is equipped with Digi-peater function. For detailed operation, please refer to the instruction manual of EJ-50U.

When using EJ-50U

Connect EJ-50U with a personal computer.

1. Connect EJ-50U and DSUB connector to this unit following the figure below. A sheet attached to the place meant for DSUB connector can be removed easily by pressing from inside.

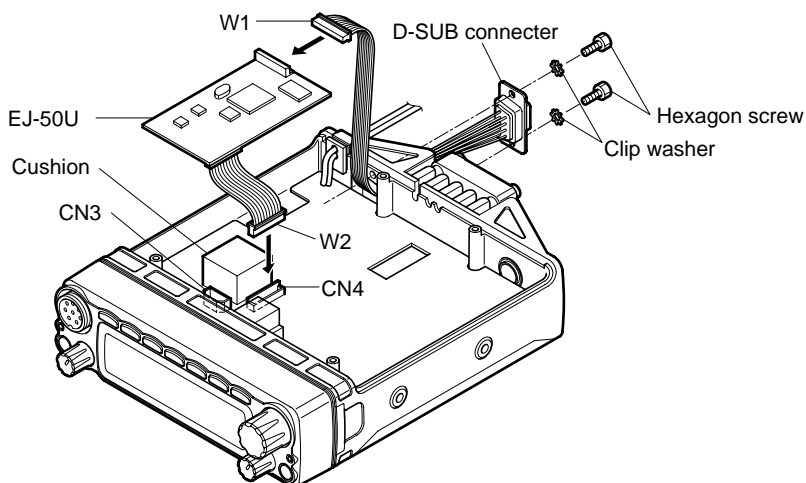

2. Insert DSUB connector W1 into EJ-50U.
3. Insert W2 of EJ-50U into CN4 of this unit.

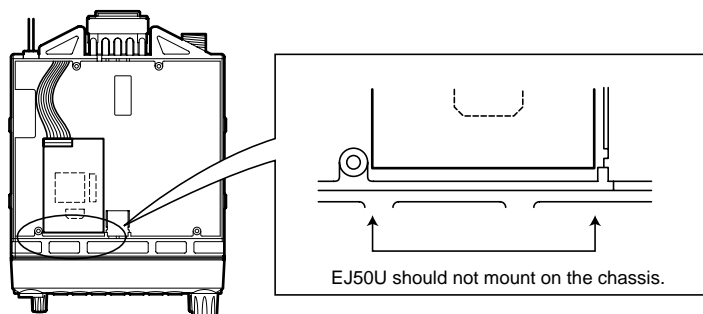

4. Connect EJ-50U with a personal computer.
Connect DSUB connector on the rear panel and a personal computer with a straight cable.

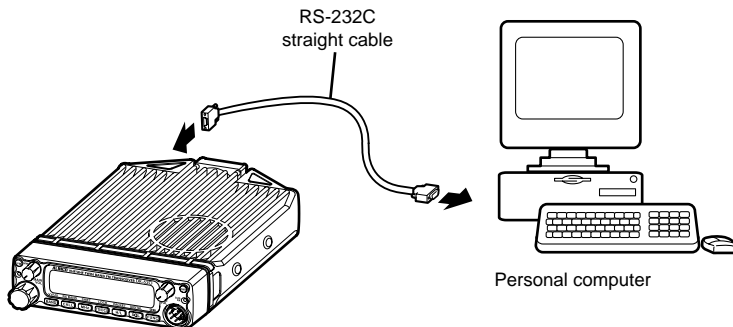

IMPORTANT: Between DSUB and a personal computer, use 9-pin RS-232C straight cable (male-female).

Packet Mode Setting

1. Press the FUNC key. While [F] icon is on, press the H/L and SQL keys. [TNC] lights up on the display and the unit enters packet mode. By the same operation, [TNC] lights off, the unit exits from packet mode and the display returns to the normal status.
2. Use the computer keyboard to send designated commands from your PC to start packet communication.

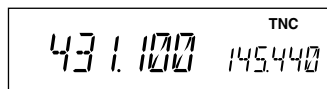

NOTE:

- Conditions of communication with a PC terminal.
Please use PC commands to program the following.

Data Speed (Transfer Rate)	: 9600bps
Data Length	: 8 bit
Parity Bit	: None
Stop Bit	: 1 bit
Flow Control	: Xon/Xoff
- What have been programmed from a PC are stored in memory even after the TNC unit is removed from the transceiver.
- This TNC unit is not equipped with all the functions an external TNC may have (Some functions may be limited).

IMPORTANT:

- Packet communication is easy to be affected by transmission and reception environment and especially in 9600bps packet mode, communication error may easily occur unless all segments of S-meter are displayed.
- While in packet mode or geolocating communication mode, tones or codes are not output even if Tone setting or DCS setting is programmed.

APRS

Install an optional TNC unit EJ-50U and an external GPS receiver to operate this function.

APRS (Automatic Packet/Position Reporting System) is a program software registered as a trademark of Bob Bruninga, WB4APR. With this program, you may trace a mobile station on the map in a computer.

For tracing a mobile station, you may need a PC installed with APRS, this unit (transceiver), TNC (EJ-50U). You may also need a GPS receiver, which catches a signal from a satellite and lets you know where you are.

APRS will reconstruct NMEA (National Marine Electronics Association) data message received from a GPS receiver. For detailed information, please see the Internet web page regarding APRS.

NOTE: GPS means Global Positioning System.

APRS Setting

APRS needs a TNC unit EJ-41U, a GPS receiver and a PC installed with APRS software. Select an external GPS receiver compatible with NMEA system.

Configuration NMEA: NMEA-0183, 4800bps/Parity Bit none/Data Length 8bit/Stop Bit 1bit

For connection

Please refer to the chapter of packet communication for EJ-50U installation and connection with a PC.

1. Connect a GPS receiver to CN5 connector inside of this unit using the provided wiring cable with some modification.
(Modification/connection of the wiring cable to the terminal is as follows)

Ensure the tube of the wiring cable goes through the slot on the chassis.

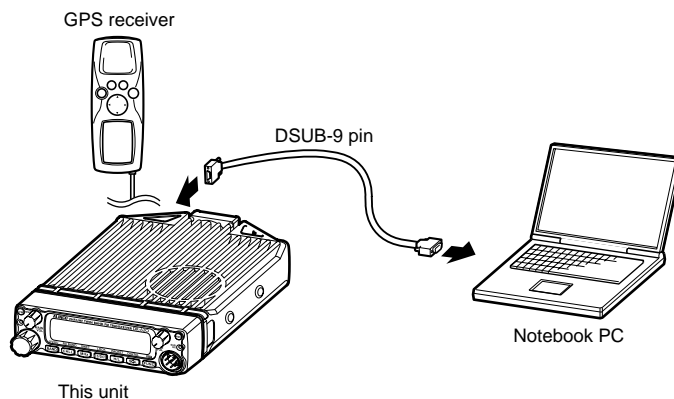
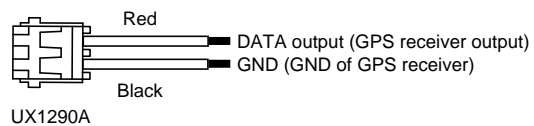
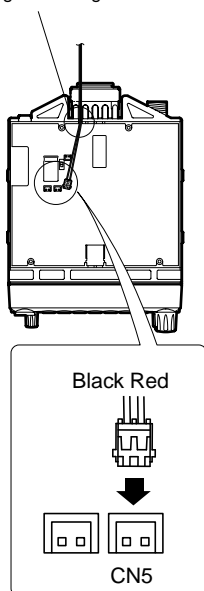

- NOTE:
- You may remove the PC after setting is finished. (What has been programmed is stored in the TNC unit. To change settings, reconnect it before setting.)
 - Setting of call sign of your station, communication speed and Beacon transmission time separation may be changed by the TNC clone of this unit without using a PC.

For operation

For detailed information, please see a list of commands and an instruction manual of EJ-50U.

1. Boot up the terminal software on the PC, press the FUNC key and press the H/L key while [F] icon is on. [TNC] lights up on the display and the unit enters Geolocating communication mode.
2. Initial screen of TNC appears on the PC.
3. Set communication speed of radio packet from the command mode (cmd:).
[Example cmd: HB 1200 or 9600]
4. Register call sign of your station.
[Example cmd: MY *****]
5. Set communication speed of the GPS port.
[Example cmd: GB 4800]
6. Set automatic transmission time separation of GPS data.
[Example cmd: LOC E 3]
7. When location data etc. is received from the GPS receiver, it will be automatically transmitted with a programmed time separation.
8. By pressing the FUNC key and then the H/L key, TNC will be turned off and transmission will also be stopped.
9. By turning on TNC again, automatic transmission will resume following the previous settings.



Geolocating communication mode

```
TASCO Radio Modem
AX.25 Level 2 Version 2.0
Release 03/Dec/99 3Chip ver 1.08
Checksum $04

cmd:HB 1200
HBAUD was 1200
cmd:MY JA1234
MYCALL was NOCALL
cmd:GB 4800
GBAUD was 4800
cmd:LOC E 6
LOCATION was EVERY 0
cmd:
```

Example of PC display

IMPORTANT:

- While using APRS software, header setting for monitoring should be OFF. (Input: cmd: LTMH OFF)
- Please use this unit and a GPS receiver reasonably apart from each other.

TNC Clone

This feature enables setting change required for APRS function without connecting to a PC. Please use this feature when setting change is desired while APRS function is in operation. Setting change is available for call sign of your station, communication speed and data transmission time separation (Setting is made in setting mode).

1. Press the FUNC key and then press the H/L key while [F] icon is on (Enter packet mode).
2. Press the CALL key with the FUNC key pressed. The display will show [TNCLON] and data programmed in setting mode for call sign of your station, communication speed and data transmission time separation are transmitted.
3. Upon completion of data transmission, the display shows [PASS]. Turning off the unit will finish clone mode and restore the normal packet mode.



Data is under transmission

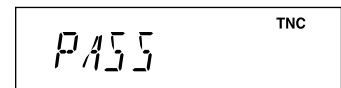

Completion of data transmission

Remote Control Operation (EMS-57 Only)

The transceiver can be controlled remotely by operating the DTMF keys on the microphone. Frequencies can also be entered directly through the key pads.

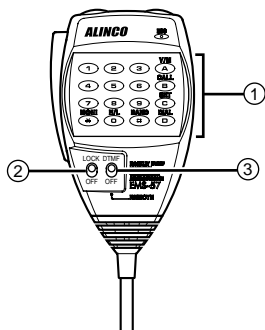

No.	Key	Function
1	DTMF	Enter the remote command or the frequency.
2	LOCK	Press LOCK to prevent the transceiver from accepting remote control inputs from the microphone.
3	DTMF/REMOTE	To operate remote control, press REMOTE.

List of Remote Control Keys

Key	Transceiver corresponding key	Function	Page
0-9	–	Direct frequency input	–
A	V/M	Memory channel access	19
B	CALL	Call channel access	23
C	SET mode	SET mode access (Note 1)	26
D	FUNC+BAND	Switching reception band	34
*	Press and hold SQL	Monitor function	24
#	BAND	Switching MAIN band	15
0	H/L	Switching transmission output	25

(Note 1) To change the SET mode menu, press the UP and DOWN keys at the top. To change its contents, press the * and # keys. Press PTT key or C key to return to the frequency display.

Entering a frequency directly

Frequencies can be entered directly by pressing the numerical keys of the microphone.

- Range of frequencies to be input
 - 87.500 - 107.995MHz (WFM reception)
 - 144.000 - 145.995MHz
 - 430.000 - 439.995MHz

1. Set the microphone DTMF/REMOTE switch to the REMOTE position.

2. DTMF keys can be used to enter from the 100MHz digit.
 (Ex.) When setting 144.20 MHz with the tuning step set to 20kHz.
 Enter 1 4 4 2 0

After entering the fifth digit a slightly longer beep is emitted and the entry is completed.

3. Canceling an entry before it is completed. Press PTT key or C key.

Entry method depending on tuning step

Depending on the set tuning step, digit entry may be necessary to the 1 kHz digit. In some cases entry to the 10 kHz digit is sufficient. For cases in which digit entry is only necessary to the 10 kHz digit some digit keys were not accepted.

The relationship between the tuning step and input method is as follows.

Tuning step	Entry completion digit	Final digit selection
5.0 kHz 8.33 kHz	1 kHz	Completion after input of the 1 kHz digit.
10.0 kHz	10 kHz	Completion after input of the 10 kHz digit.
12.5 kHz	10 kHz	When you input the 10 kHz digit, the 1 kHz digit set as follows. 0...00.0, 1...12.5, 2...25.0, 3...37.5, 4...invalid 5...50.0, 6...62.5, 7...75.0, 8...87.5, 9...invalid
15.0 kHz	10 kHz	Completion after input of the 10 kHz digit.
20.0 kHz	10 kHz	Completion after input of the 10 kHz digit.
25 kHz	10 kHz	When you input the 10 kHz digit, the 1 kHz digit set as follows. 0...00.0, 2...25.0, 5...50.0, 7...75.0, Other entries are invalid.
30 kHz	10 kHz	When you input the 10 kHz digit, the 1 kHz digit set as follows.
50 kHz	10 kHz	When you input the 10 kHz digit, the 1 kHz digit set as follows. 0...00.0, 5...50.0

Maintenance / Reference

Reset

Resetting the unit returns all programmed contents to their factory default setting.

1. Press the PWR key for more than 1 second with the FUNC key pressed to turn the power on.
2. All segments of the LCD will be displayed, then default settings are displayed.

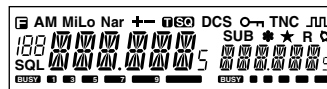

All LCD segments

NOTE: While holding the FUNC key down, turn the power on. All segments of the LCD will be displayed, then default settings are displayed.

IMPORTANT: While holding the FUNC key down, turn the power on. All segments of the LCD will be displayed, then default settings are displayed.

Factory Default Settings

	DR-620T	DR-620E	DR-620TA
MAIN band	VHF	VHF	VHF
VFO frequency (VHF)	145.00MHz	145.00MHz	165.00MHz
(UHF)	445.00MHz	435.00MHz	460.00MHz
CALL frequency (VHF)	145.00MHz	145.00MHz	145.00MHz
(UHF)	445.00MHz	435.00MHz	460.00MHz
Memory channel	-	-	-
Offset direction	-	-	-
Offset frequency (V/U)	600kHz/5MHz	600kHz/7.6MHz	600kHz/5MHz
Channel step	5kHz	12.5kHz	5kHz
Channel step (FM)	100kHz	100kHz	100kHz
Tone-squelch setting	-	-	-
Tone frequency	88.5Hz	88.5Hz	88.5Hz
DCS setting	-	-	-
DCS code	023	023	023
Output power	HI	HI	HI
Scan resuming condition	timer	timer	timer
Beep volume setting	2	2	2
Time-Out-Timer	OFF	OFF	OFF
TOT penalty	OFF	OFF	OFF
APO	OFF	OFF	OFF
Tone burst sound setting	ALERT	1750Hz	ALERT
Clock shift setting	OFF	OFF	OFF
Bell setting	OFF	OFF	OFF
Busy-Channel-Lock-Out setting	OFF	OFF	OFF
Theft Alarm setting	OFF	OFF	OFF
Display color setting	1 (Amber)	1 (Amber)	1 (Amber)
Dimmer setting	4	4	4
Squelch level	02	02	02

Troubleshooting

Please check the list below concluding that the transceiver is faulty.

If a problem persists, reset the transceiver. This can sometimes correct erroneous operation.

Problem	Possible Causes	Potential Solutions
Power is on, nothing appears on the Display	<ul style="list-style-type: none"> a. + and - polarities of power connection are reversed. b. Fuse is blown. c. ACC power supply is connected but is OFF. 	<ul style="list-style-type: none"> a. Correctly connect the red lead and the black lead of the DC power cable provided respectively to the plus terminal and the minus terminal. b. Check and solve the problem resulting in blown fuse and replace it with a new one with the rated capacity. c. Turn on the ACC power supply.
Display is too dim.	Dimmer setting is "LAMP 1 - 3."	Make the dimmer setting "LAMP 4."
No sound comes from the speaker. The unit does not receive.	<ul style="list-style-type: none"> a. The volume knob is rotated too much counter-clockwise. b. Squelch is muted. c. Tone or DCS squelch is active d. PTT key of the microphone is pressed for transmission. e. External speaker is connected. 	<ul style="list-style-type: none"> a. Set the volume knob properly. b. Decrease squelch level. c. Turn tone or DCS squelch off. d. Immediately turn off the PTT key. e. Pull the jack off the terminal of the external speaker.
Keys and the dial do not function.	Key-lock function is activated ([] is on).	Cancel key-lock function.
Rotating the dial will not change memory channel.	<ul style="list-style-type: none"> a. No memory is programmed. b. The unit is in CALL mode. 	<ul style="list-style-type: none"> a. Program memory. b. Press V/M key for memory mode.
Pressing the UP/DOWN key will not change frequencies or memory channels.	<ul style="list-style-type: none"> a. The unit is in CALL mode. b. Lock switch is ON. 	<ul style="list-style-type: none"> a. Switch to VFO mode or memory mode. b. Turn off the Lock switch.
PTT key is pressed but transmission does not occur.	<ul style="list-style-type: none"> a. Microphone terminal is not properly inserted. b. Antenna is not connected. c. SHIFT is set for OFF band transmission. d. The unit is in SUB band reception mode. 	<ul style="list-style-type: none"> a. Properly insert the microphone terminal. b. Properly connect the antenna. c. Cancel SHIFT or set within the band. d. Switch to the MAIN band.

Problem	Possible Causes	Potential Solutions
Packet communication does not function.	<ul style="list-style-type: none"> a. TNC is not connected or set properly. b. The unit is not in the packet mode. c. The squelch is open. d. The data transmission speed is not configured. e. A PC cable other than the straight type is used. 	<ul style="list-style-type: none"> a. Make sure the connections and configurations are properly set. b. Switch to the packet mode. c. Adjust the squelch level where it will open by a reception signal. d. Adjust the speed by the PC. e. Use a straight type PC cable.
APRS does not function.	<ul style="list-style-type: none"> a. The unit is not in the packet mode. b. The unit is not configured for automatic transmission. c. The squelch is open. d. The GPS receiver is not geolocating. 	<ul style="list-style-type: none"> a. Switch to the packet mode. b. Use the PC to set transmission time separation. c. Adjust the squelch level where it will open by a reception signal. d. Wait until the GPS receiver properly geolocates.
The unit does not enter V-V/U-U mode.	Either the MAIN or SUB side is in memory mode.	Switch to VFO mode.

IMPORTANT: When reception frequencies fall in any one of the formulas below, the unit may receive non-modulated signal. This is due to the structure of frequencies of this unit and not a malfunction of the unit.

- (Reception frequency on the MAIN side - 45.1MHz)
: Reception frequency on the SUB side - 43.4MHz (In u-u)
- (FM reception frequency + 10.7MHz x 4) : UHF reception frequency - 90.2MHz
- (FM reception frequency + 10.7MHz x 5) :UHF reception frequency
- (Reception frequency in the UHF band - 45.1MHz) x 2
- (Reception frequency in the VHF band - 21.7MHz) x 6 : 45.1MHz

Optional accessories

- EMS-57 DTMF equipped microphone
(This comes standard with the DR-620T)

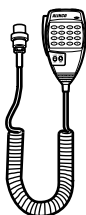

- EMS-53 Microphone
(This comes standard with the DR-620E)

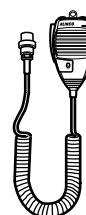

- EJ-50U TNC unit

Transmitter Chart

DR-620T, DR-620E

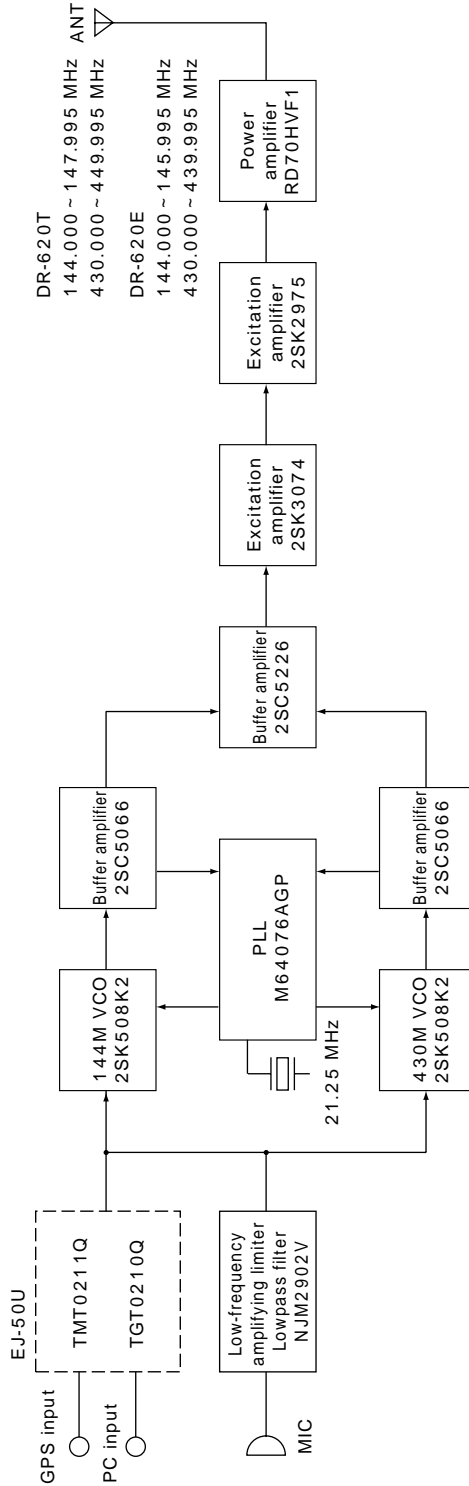

Specification

General	DR-620T, DR-620E
Frequency coverage	
DR-620T	87.500 - 107.995MHz (WFM) 108.000 - 135.995MHz (AM RX) 136.000 - 173.995MHz (RX) 144.000 - 147.995MHz(TX) 335.000 - 479.995MHz (RX) 430.000 - 449.995MHz (TX)
DR-620E	87.500 - 107.995MHz (WFM) 144.000 - 145.995MHz (RX, TX) 430.000 - 439.995MHz (RX, TX)
Operating mode	16K0F3E (Wide mode), 8K50F3E (Narrow mode)
Frequency resolution	5, 8.33, 10, 12.5, 15, 20, 25, 30, 50, 100kHz
Number of memory channels	200
Antenna impedance	50Ω unbalanced
Power requirement	13.8V DC +/-15% (11.7 to 15.8V)
Ground method	Negative ground
Current drain	Receive: 0.6A(Max.), 0.4A(Squelched) Transmit: 11.0A
Operating temperature	- 10 °C to 60 °C
Frequency stability	+/- 2.5ppm
Dimensions	140(w) - 40(h) - 185(d) mm (w/o knobs)
Weight	Approx. 1.0kg
Transmitter	
Output power	High:50W(VHF), 35W(UHF)Mid:10WLow:5W
Modulation system	Variable reactance frequency modulation
Maximum frequency deviation	+/- 5kHz (Wide mode) +/-2.5kHz (Narrow mode)
Spurious emission	-60dB
Adjacent channel power	-60dB
Modulation Distortion	Less than 3%
Microphone impedance	2kΩ
Receiver	
Sensitivity	-14dBu for 12dB SINAD
Receiver circuitry	Double conversion superheterodyne
Intermediate frequency	1st 21.7MHz 2nd 450kHz (VHF) 1st 45.1MHz 2nd 455kHz (UHF)
Squelch sensitivity	-18dBu
Selectivity(-6dB/-60dB)	12kHz/24kHz
Spurious and image rejection ratio	70dB
Audio output power	2.0W (8Ω,10%THD)

*All specifications are subject to change without notice or obligation.

MEMO