FCC Test Report

Report No.: AGC00725200401FE08

FCC ID : PH3DR-06TA
PRODUCT DESIGNATION : VHF FM MOBILE TRANSCEIVER
BRAND NAME : ALINCO
MODEL NAME : DR-06TA
APPLICANT : Alinco Incorporated, Electronics Division
DATE OF ISSUE : Apr. 30, 2020
STANDARD(S) : FCC Part 15 Rules
REPORT VERSION : V 1.0

Attestation of Global Compliance (Shenzhen) Co., Ltd

CAUTION:

This report shall not be reproduced except in full without the written permission of the test laboratory and shall not be quoted out of context.



Report Revise Record

Report Version	Revise Time	Issued Date	Valid Version	Notes
V1.0	/	Apr. 30, 2020	Valid	Initial Release

TABLE OF CONTENTS

1. VERIFICATION OF COMPLIANCE	4
2. PRODUCT INFORMATION	5
3. IDENTIFICATION OF THE RESPONSIBLE TESTING LOCATION	6
4. SUPPORT EQUIPMENT LIST	7
5. SYSTEM DESCRIPTION	7
6. SUMMARY OF TEST RESULTS	8
7. FCC RADIATED EMISSION TEST	9
7.1. TEST EQUIPMENT OF RADIATED EMISSION	9
7.2. LIMITS OF RADIATED EMISSION TEST	9
7.3 BLOCK DIAGRAM OF RADIATED EMISSION TEST	9
7.4 PROCEDURE OF RADIATED EMISSION TEST	11
7.5 TEST RESULT OF RADIATED EMISSION TEST	12
8. CONDUCTED EMISSION TEST	14
8.1 PROVISIONS APPLICABLE	14
8.2 MEASUREMENT PROCEDURE	14
8.3 TEST SETUP BLOCK DIAGRAM	15
8.4 TEST RESULT	16
9. ANTENNA CONDUCTED POWER FOR RECEIVERS	18
10. SANNING RECEIVERS AND FREQUENCY CONVERTERS USED WITH SANNING RECEIVERS	21
APPENDIX 1 PHOTOGRAPHS OF TEST SETUP	22

1. VERIFICATION OF COMPLIANCE

Applicant	Alinco Incorporated, Electronics Division
Address	Yodoyabashi Dai Building 13F,4-4-9 Korasibashi, Chuo-ku Osaka,541-0043 Japan
Manufacturer	Alinco Incorporated, Electronics Division
Address	Yodoyabashi Dai Building 13F,4-4-9 Korasibashi, Chuo-ku Osaka,541-0043 Japan
Factory	Alinco Incorporated, Electronics Division
Address	Yodoyabashi Dai Building 13F,4-4-9 Korasibashi, Chuo-ku Osaka,541-0043 Japan
Product Designation	VHF FM MOBILE TRANSCEIVER
Brand name	ALINCO
Test Model	DR-06TA
Hardware Version	V1.0
Software Version	V1.0
Measurement Procedure	ANSI C63.4: 2014
Date of test	Apr. 02, 2020~Apr. 30, 2020
Deviation	No any deviation from the test method.
Condition of Test Sample	Normal

The above equipment was tested by Attestation Of Global Compliance (Shenzhen) Co., Ltd. for compliance with the requirements set forth in the FCC Rules and Regulations Part 15, the measurement procedure according to ANSI C63.4:2014. This said equipment in the configuration described in this report shows the maximum emission levels emanating from equipment are within the compliance requirements. The test results of this report relate only to the tested sample identified in this report.

Prepared By Calvin Liu
 Calvin Liu
 (Project Engineer) Apr. 30, 2020

Reviewed By Max Zhang
 Max Zhang
 (Reviewer) Apr. 30, 2020

Approved By Forrest Lei
 Forrest Lei
 (Authorized Officer) Apr. 30, 2020

2. PRODUCT INFORMATION

The EUT is a **VHF FM MOBILE TRANSCEIVER** designed for voice communication. It is designed by way of utilizing the F3E modulation achieves the system operating.

A major technical description of EUT is described as following:

Communication Type	Voice / Tone only
Modulation	FM
RX Frequency Range	RX: 50.000MHz ~ 53.995MHz
Emission Type	F3E
Antenna Designation	Detachable
Antenna type	External antenna
Antenna Gain	0dBi
Power Supply	DC 13.8V

I/O Port Information (Applicable Not Applicable)

I/O Port of EUT			
I/O Port Type	Q'TY	Cable	Tested with
Antenna Connect Port	1	0	1

3. IDENTIFICATION OF THE RESPONSIBLE TESTING LOCATION

Test Site	Attestation of Global Compliance (Shenzhen) Co., Ltd
Location	1-2/F, Building 19, Junfeng Industrial Park, Chongqing Road, Heping Community, Fuhai Street, Bao'an District, Shenzhen, Guangdong, China
Designation Number	CN1259
FCC Test Firm Registration Number	975832
A2LA Cert. No.	5054.02
Description	Attestation of Global Compliance(Shenzhen) Co., Ltd is accredited by A2LA

List Of Test Equipment:

TEST EQUIPMENT OF CONDUCTED EMISSION TEST

Equipment	Manufacturer	Model	S/N	Cal. Date	Cal. Due
TEST RECEIVER	R&S	ESCI	100096	Jul. 12, 2019	Jul. 11, 2020
AMN/LISN	R&S	ESH2-Z5	100086	Aug. 22, 2019	Aug. 21, 2020
TEST SOFTWARE	FR	EZ-EMC	AGC-CON03 A	--	--

TEST EQUIPMENT OF RADIATED EMISSION TEST

Equipment	Manufacturer	Model	S/N	Cal. Date	Cal. Due
TEST RECEIVER	R&S	ESPI	101206	Jul. 12, 2019	Jul. 11, 2020
ANTENNA	SCHWARZBECK	VULB9168	494	Jan. 09, 2019	Jan. 08, 2021
TEST RECEIVER	R&S	ESCI	100694	June 27, 2019	June 26, 2020
ANTENNA	SCHWARZBECK	VULB9168	D69250	Sep. 20, 2019	Sep. 19, 2020
POSITIONING CONTROLLER	MF	MF-7802	MF780208285	--	--
HORN ANTENNA	ETS LINDGREN	3117	00034609	May. 16, 2019	May. 15, 2021
RF Communication Test Set	HP	8920B	--	Jul. 12, 2019	Jul. 11, 2020
Vector Analyzer	Agilent	E4440A	--	Feb. 25, 2019	Feb. 24, 2021
Attenuator	Weinachel Corp	58-30-33	ML030	Jul. 12, 2019	Jul. 11, 2020

4. SUPPORT EQUIPMENT LIST

Device Type	Manufacturer	Model Name	Serial No.	Data Cable	Power Cable
50ohm dummy load	--	--	--	--	--
Hand microphone	--	--	--	0.15m	--

5. SYSTEM DESCRIPTION

EUT test procedure:

1. Connect EUT and peripheral devices.
2. Power on the EUT, the EUT begins to work.
3. Make sure the EUT normal working.

EMC TEST MODES

No.	TEST MODES
1	Scanning mode
2	Scanning stopped/Receiving at low channel of 50.000 MHz -53.995MHz
3	Scanning stopped/Receiving at middle channel of 50.000 MHz -53.995MHz
4	Scanning stopped/Receiving at high channel of 50.000 MHz -53.995MHz

Note: Only the result of the worst case was recorded in the report.

6. SUMMARY OF TEST RESULTS

FCC Rules	Description Of Test	Result
§15.107	Conduction Emission	Compliant
§15.109	Radiated Emission	Compliant
§15.111	Antenna Conducted Power for receivers	Compliant
§15.121(b)	Scanning receivers and frequency converters used with scanning receivers	Compliant

7. FCC RADIATED EMISSION TEST

7.1. TEST EQUIPMENT OF RADIATED EMISSION

7.2. LIMITS OF RADIATED EMISSION TEST

Frequency (MHz)	Distance (m)	Maximum Field Strength Limit (dBuV/m/ Q.P.)
30~88	3	41.0
88~216	3	45.0
216~960	3	48.0
960~2000	3	53.5

**Note: The lower limit shall apply at the transition frequency. Because the EUT RX frequency range up to 480 MHz, so the upper the frequency range up to 2 GHz.

7.3 BLOCK DIAGRAM OF RADIATED EMISSION TEST

RADIATED EMISSION TEST SETUP 30MHz-1000MHz

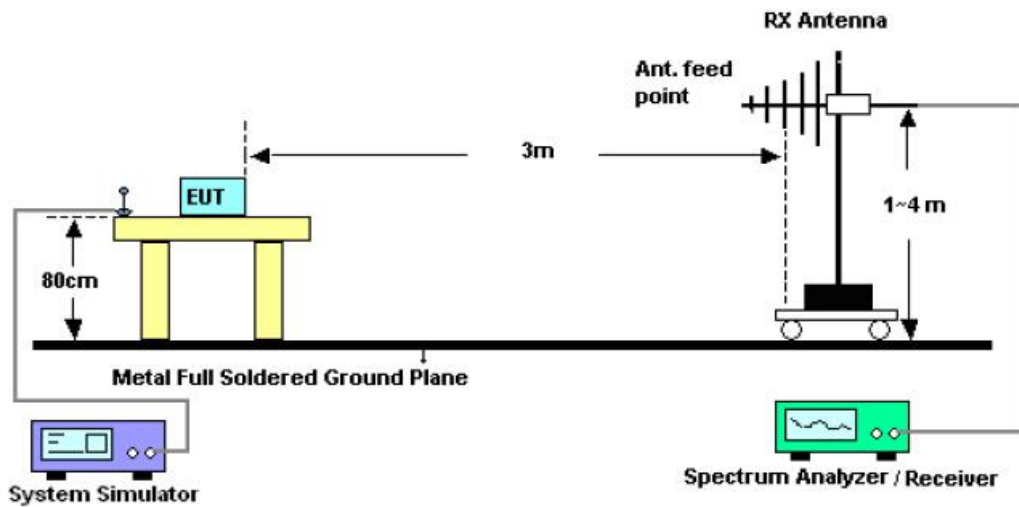

RADIATED EMISSION TEST SETUP ABOVE 1000MHz

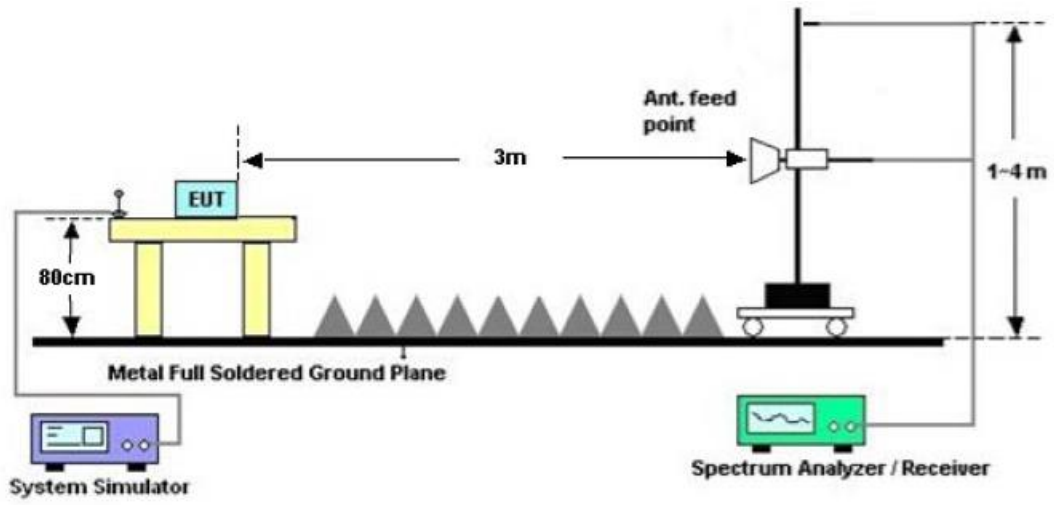

7.4 PROCEDURE OF RADIATED EMISSION TEST

- 1) The equipment was set up as per the test configuration to simulate typical actual usage per the user's manual. When the EUT is a tabletop system, a wooden turntable with a height of 0.8 meters is used which is placed on the ground plane as per ANSI C63.4 (see Test Facility for the dimensions of the ground plane used). When the EUT is floor-standing equipment, it is placed on the ground plane which has a 3-12 mm non-conductive covering to insulate the EUT from the ground plane.
- 2) Support equipment, if needed, was placed as per ANSI C63.4.
- 3) All I/O cables were positioned to simulate typical actual usage as per ANSI C63.4.
- 4) The EUT received power by DC 13.80V.
- 5) The antenna was placed at 3 meter away from the EUT as stated in FCC Part 15. The antenna connected to the Analyzer via a cable and at times a pre-amplifier would be used.
- 6) The Analyzer / Receiver quickly scanned from 30MHz to 1000MHz. The EUT test program was started. Emissions were scanned and measured rotating the EUT to 360 degrees and positioning the antenna 1 to 4 meters above the ground plane, in both the vertical and the horizontal polarization, to maximize the emission reading level.
- 7) The test mode(s) were scanned during the test:
- 8) Recorded at least the six highest emissions. Emission frequency, amplitude, antenna position, polarization and turntable position were recorded into a computer in which correction factors were used to calculate the emission level and compare reading to the applicable limit and Q.P./Peak reading is presented. For emissions below 1GHz, use 120KHz RBW and $VBW \geq 3RBW$ for QP reading.
- 9) For emissions above 1GHz, use 1MHz RBW and 3MHz VBW for peak reading. Then 1MHz RBW and 10Hz VBW for average reading in spectrum analyzer.
- 10) When the radiated emissions limits are expressed in terms of the average value of the emissions, and pulsed operation is employed, the measurement field strength shall be determined by averaging over one complete pulse train, including blanking intervals, as long as the pulse train does not exceed 0.1 seconds. As an alternative (provided the transmitter operates for longer than 0.1 seconds) or in cases where the pulse train exceeds 0.1 seconds, the measured field strength shall be determined from the average absolute voltage during a 0.1 second interval during which the field strength is at its maximum values.
- 11) If the emissions level of the EUT in peak mode was 3 dB lower than the average limit specified, then testing will be stopped and peak values of EUT will be reported, otherwise, the emissions which do not have 3 dB margin will be repeated one by one using the quasi-peak method for below 1GHz.
- 12) For testing above 1GHz, the emissions level of the EUT in peak mode was lower than average limit (that means the emissions level in peak mode also complies with the limit in average mode), then testing will be stopped and peak values of EUT will be reported, otherwise, the emissions will be measured in average mode again and reported.
- 13) In case the emission is lower than 30MHz, loop antenna has to be used for measurement and the recorded data should be QP measured by receiver. High - Low scan is not required in this case.
- 14) The test data of the worst case condition (mode 1) was reported on the following Data page

7.5 TEST RESULT OF RADIATED EMISSION TEST

Radiated Emission Test –Horizontal -3m Below 1G

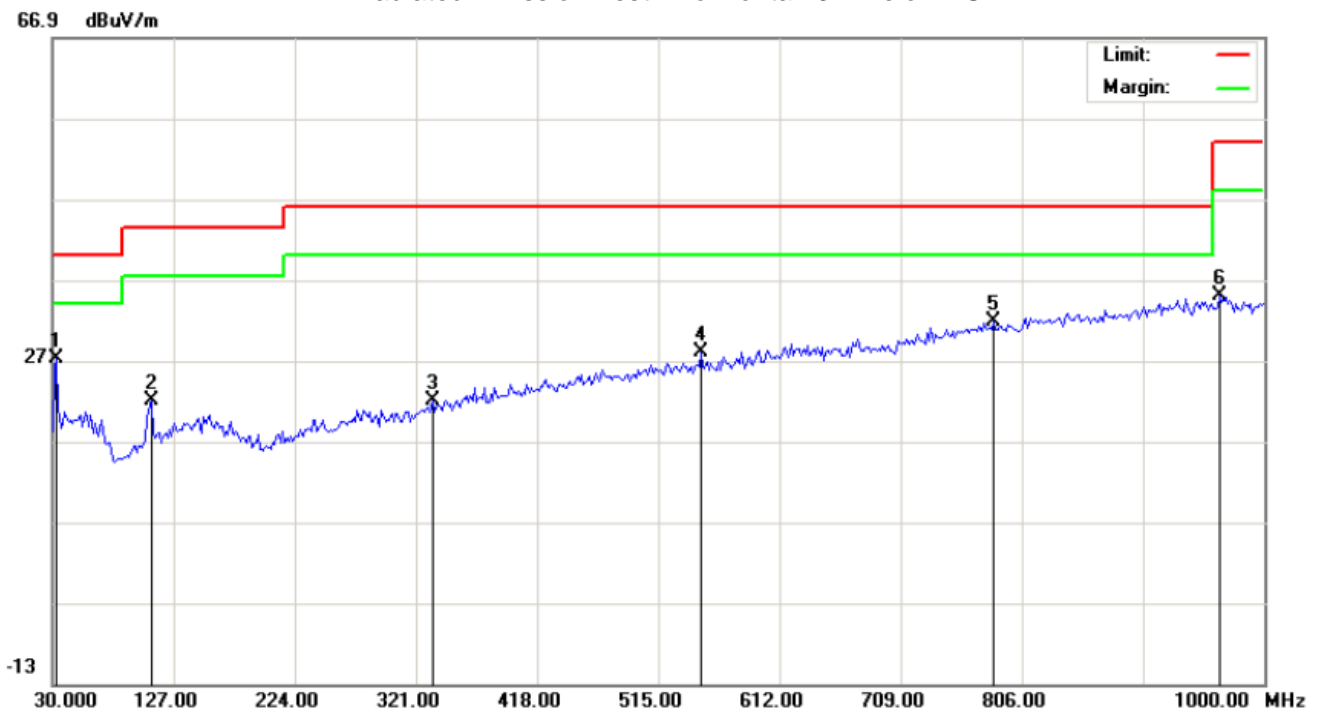

No.	Mk	Freq.	Reading	Factor	Measurement	Limit	Over	Detector	Antenna Height	Table Degree	Comment
		MHz	dBuV	dB/m	dBuV/m	dBuV/m	dB		cm	degree	
1	*	33.2333	8.92	18.27	27.19	40.00	-12.81	peak			
2		109.2167	5.07	16.91	21.98	43.50	-21.52	peak			
3		333.9333	1.34	20.66	22.00	46.00	-24.00	peak			
4		548.9500	2.14	25.95	28.09	46.00	-17.91	peak			
5		783.3667	1.78	30.03	31.81	46.00	-14.19	peak			
6		964.4333	2.73	32.25	34.98	54.00	-19.02	peak			

RESULT: PASS

Radiated Emission Test –Vertical -3m Below 1G

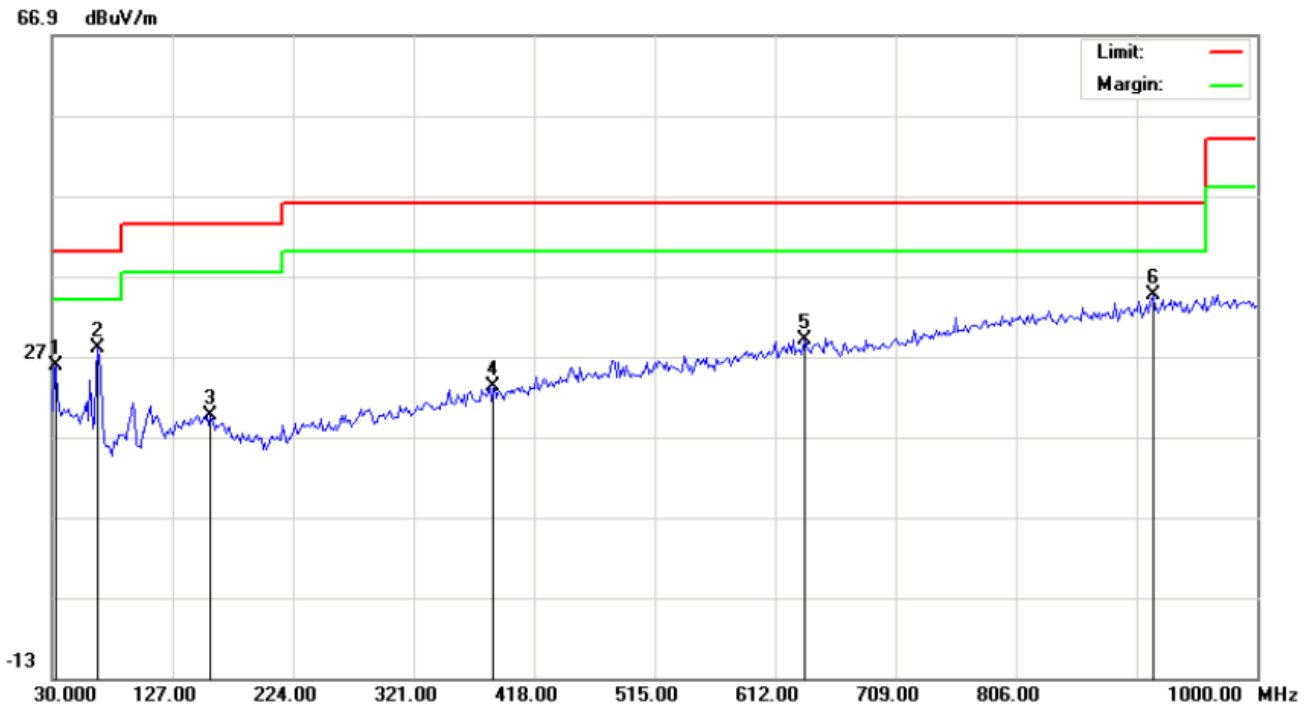

No.	Mk	Freq.	Reading	Factor	Measurement	Limit	Over	Detector	Antenna	Table	Comment
		MHz	dBuV	dB/m	dBuV/m	dBuV/m	dB		Height	Degree	
									cm	degree	
1		33.2333	7.62	18.27	25.89	40.00	-14.11	peak			
2		67.1833	10.34	17.61	27.95	40.00	-12.05	peak			
3		157.7167	0.48	19.19	19.67	43.50	-23.83	peak			
4		385.6666	0.71	22.48	23.19	46.00	-22.81	peak			
5		636.2500	1.56	27.38	28.94	46.00	-17.06	peak			
6	*	915.9333	2.80	31.84	34.64	46.00	-11.36	peak			

RESULT: PASS

- Note:**
1. Factor=Antenna Factor + Cable loss - Amplifier gain, Margin=Measurement-Limit.
 2. The “Factor” value can be calculated automatically by software of measurement system.
 3. Emissions range from 1GHz to 2GHz have 20dB margin. No recording in the test report.
 4. Only the data of the worst case would be record in this test report.

8. CONDUCTED EMISSION TEST

8.1 PROVISIONS APPLICABLE

For an intentional radiator that is designed to be connected to the public utility (AC) power line, the radio frequency voltage that is conducted back onto the AC power line on any frequencies within the band 150 KHz to 30 MHz shall not exceed the limits in the following table, as measured using a 50uH/50 ohms line impedance stabilization network (LISN). Compliance with the provisions of this paragraph shall be based on the measurement of the radio frequency voltage between each power line and ground at the power terminal. The lower limit applies at the boundary between the frequencies ranges.

Frequency of Emission (MHz)	Conducted Limit(dBuV)	
	Quasi-Peak	Average
0.15 – 0.5	66 to 56 *	56 to 46 *
0.5 – 5	56	46
5 – 30	60	50

* Decreases with the logarithm of the frequency.

8.2 MEASUREMENT PROCEDURE

- (1) The equipment was set up as per the test configuration to simulate typical actual usage per the user's manual. When the EUT is a tabletop system, a wooden table with a height of 0.8 meters is used and is placed on the ground plane as per ANSI C63.4 (see Test Facility for the dimensions of the ground plane used). When the EUT is a floor-standing equipment, it is placed on the ground plane which has a 3-12 mm non-conductive covering to insulate the EUT from the ground plane.
- (2) Support equipment, if needed, was placed as per ANSI C63.4.
- (3) All I/O cables were positioned to simulate typical actual usage as per ANSI C63.4.
- (4) The EUT received DC 13.80V power through a Line Impedance Stabilization Network (LISN) which supplied power source and was grounded to the ground plane.
- (5) All support equipments received AC power from a second LISN, if any.
- (6) The EUT test program was started. Emissions were measured on each current carrying line of the EUT using a spectrum Analyzer / Receiver connected to the LISN powering the EUT. The LISN has two monitoring points: Line 1 (Hot Side) and Line 2 (Neutral Side). Two scans were taken: one with Line 1 connected to Analyzer / Receiver and Line 2 connected to a 50 ohm load; the second scan had Line 1 connected to a 50 ohm load and Line 2 connected to the Analyzer / Receiver.
- (7) Analyzer / Receiver scanned from 150 KHz to 30MHz for emissions in each of the test modes.

During the above scans, the emissions were maximized by cable manipulation.

8.3 TEST SETUP BLOCK DIAGRAM

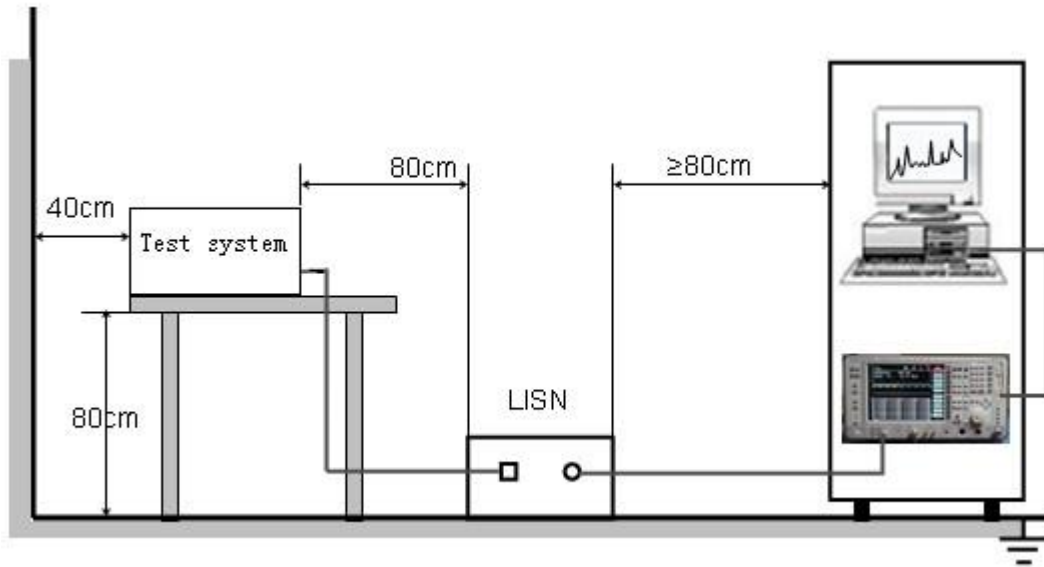

8.4 TEST RESULT

CONDUCTED EMISSION TEST-Positive

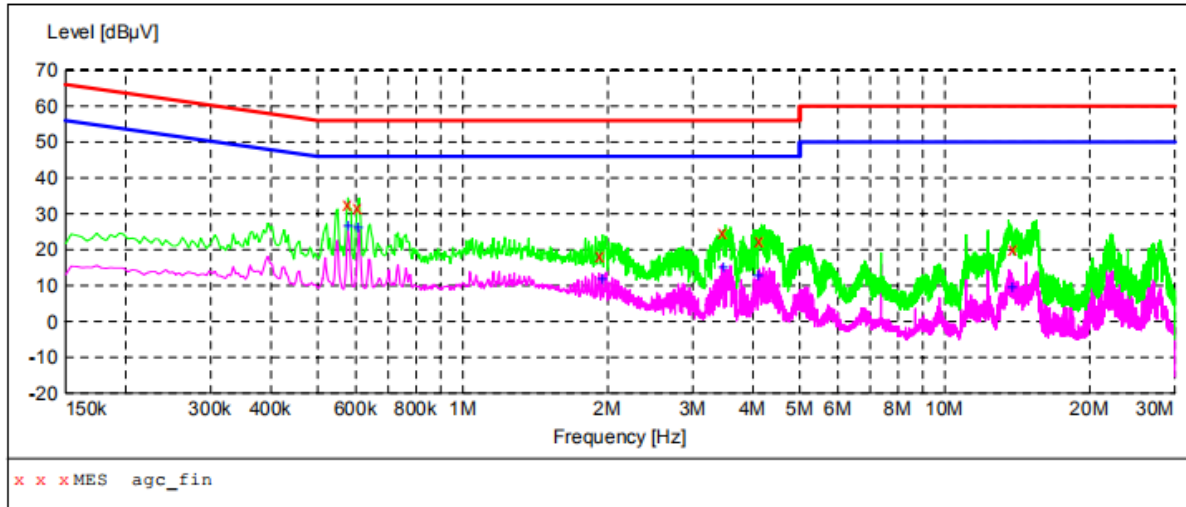

MEASUREMENT RESULT: "agc_fin"

2020/5/7 9:21

Frequency MHz	Level dBµV	Transd dB	Limit dBµV	Margin dB	Detector	Line	PE
0.578000	32.50	11.3	56	23.5	QP	N	GND
0.606000	31.80	11.3	56	24.2	QP	N	GND
1.926000	18.20	11.3	56	37.8	QP	N	GND
3.466000	24.80	11.4	56	31.2	QP	N	GND
4.110000	22.30	11.4	56	33.7	QP	N	GND
13.814000	20.00	11.9	60	40.0	QP	N	GND

MEASUREMENT RESULT: "agc_fin2"

2020/5/7 9:21

Frequency MHz	Level dBµV	Transd dB	Limit dBµV	Margin dB	Detector	Line	PE
0.578000	26.40	11.3	46	19.6	AV	N	GND
0.610000	26.30	11.3	46	19.7	AV	N	GND
1.946000	11.80	11.3	46	34.2	AV	N	GND
3.470000	14.90	11.4	46	31.1	AV	N	GND
4.110000	12.90	11.4	46	33.1	AV	N	GND
13.814000	9.50	11.9	50	40.5	AV	N	GND

RESULT: PASS

CONDUCTED EMISSION TEST-Negative

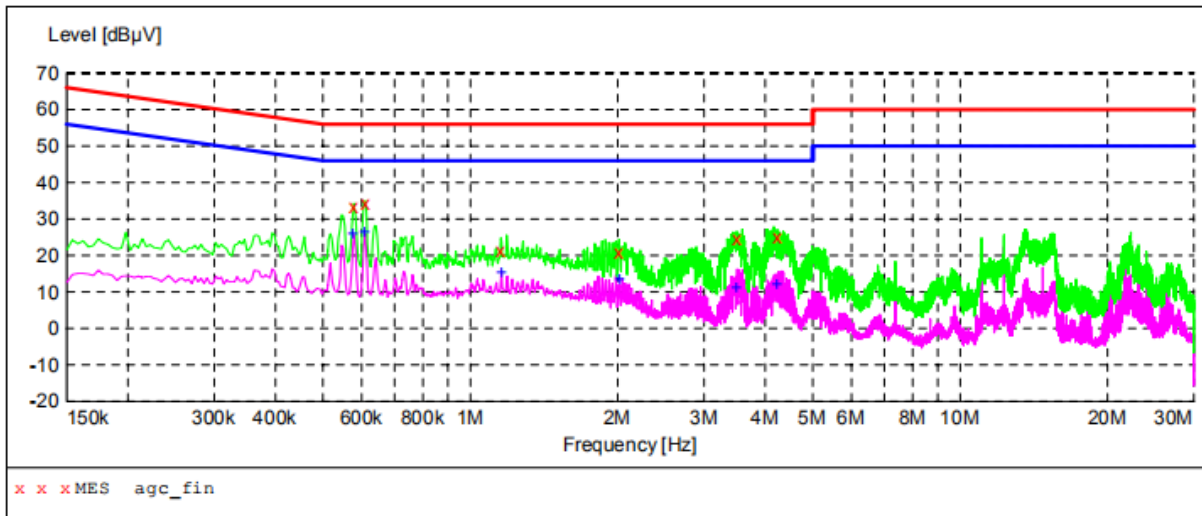

MEASUREMENT RESULT: "agc_fin"

2020/5/7 9:27

Frequency MHz	Level dBµV	Transd dB	Limit dBµV	Margin dB	Detector	Line	PE
0.578000	33.50	11.3	56	22.5	QP	N	GND
0.610000	34.30	11.3	56	21.7	QP	N	GND
1.158000	21.50	11.3	56	34.5	QP	N	GND
2.014000	20.80	11.3	56	35.2	QP	N	GND
3.498000	24.50	11.4	56	31.5	QP	N	GND
4.230000	25.00	11.4	56	31.0	QP	N	GND

MEASUREMENT RESULT: "agc_fin2"

2020/5/7 9:27

Frequency MHz	Level dBµV	Transd dB	Limit dBµV	Margin dB	Detector	Line	PE
0.578000	26.20	11.3	46	19.8	AV	N	GND
0.610000	26.40	11.3	46	19.6	AV	N	GND
1.158000	15.20	11.3	46	30.8	AV	N	GND
2.014000	13.40	11.3	46	32.6	AV	N	GND
3.498000	11.30	11.4	46	34.7	AV	N	GND
4.230000	12.10	11.4	46	33.9	AV	N	GND

RESULT: PASS

9. ANTENNA CONDUCTED POWER FOR RECEIVERS

LIMIT

The antenna conducted power of the receiver as defined in §15.111 shall not exceed the values given in the following tables

Frequency Range	9 KHz to 2GHz
Limit	2.0 nW (-57 dBm)

TEST CONFIGURATION

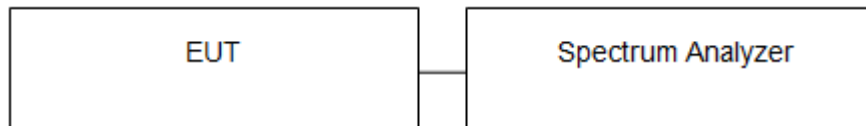

TEST PROCEDURE

1. The receiver antenna terminal connected to a spectrum analyzer.
2. The test data of the worst case condition (mode 1) was reported on the following Data page.

TEST RESULTS

Conducted Measurement (9 KHz to 150 KHz)

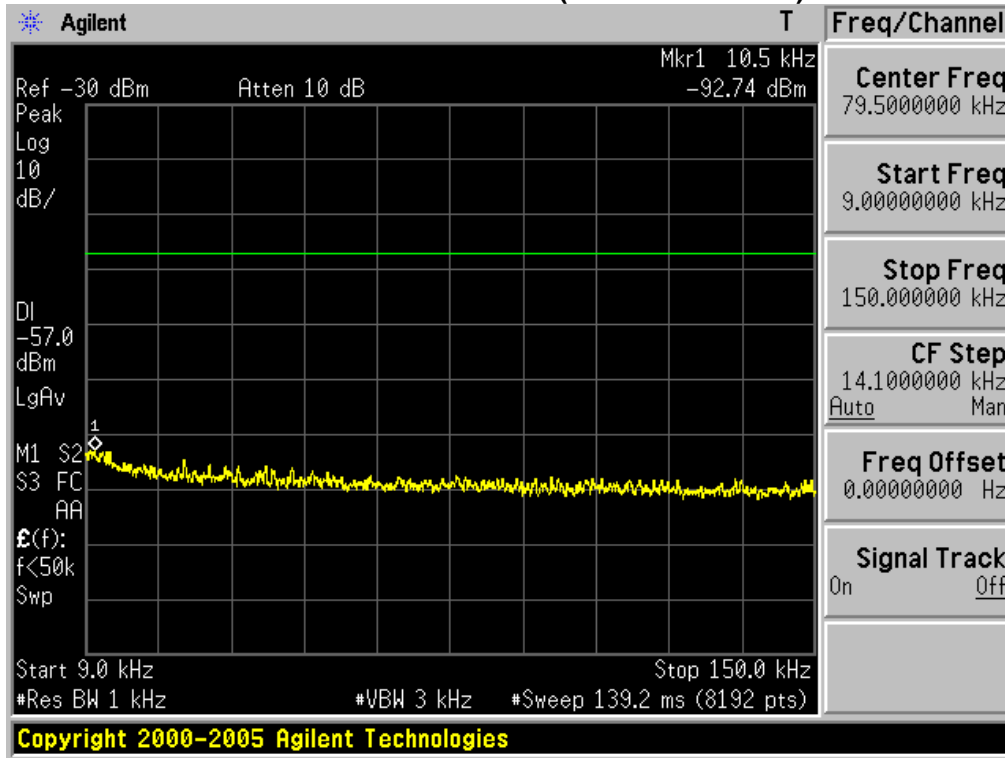

Conducted Measurement (150 KHz to 30MHz)

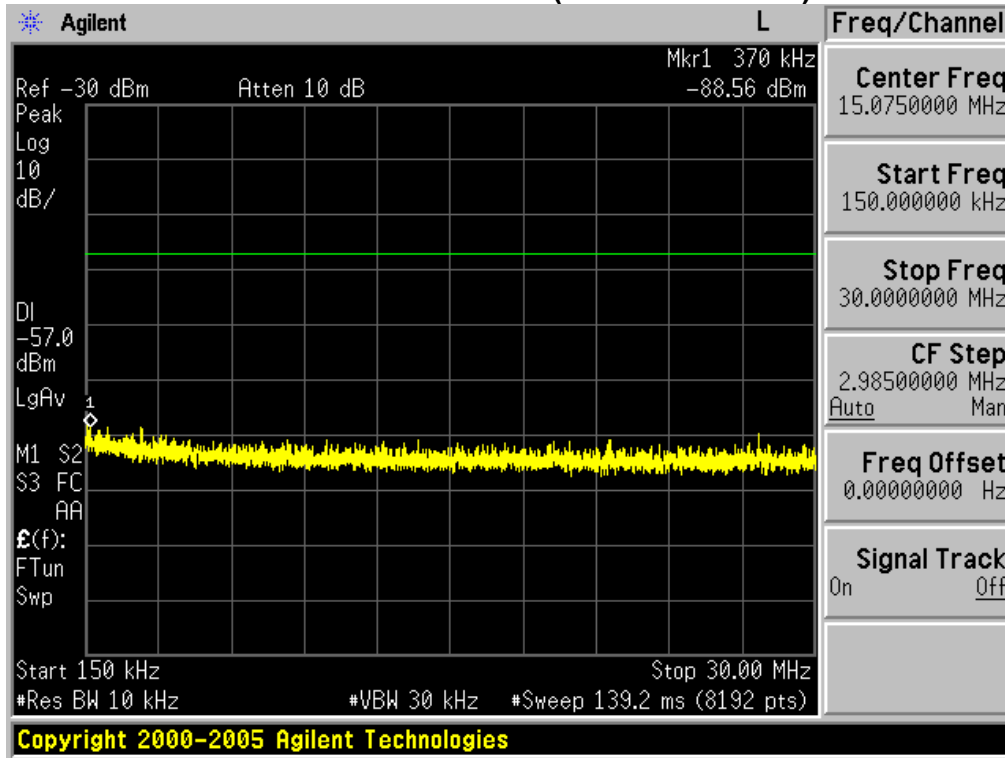

Conducted Measurement (30MHz to 1GHz)

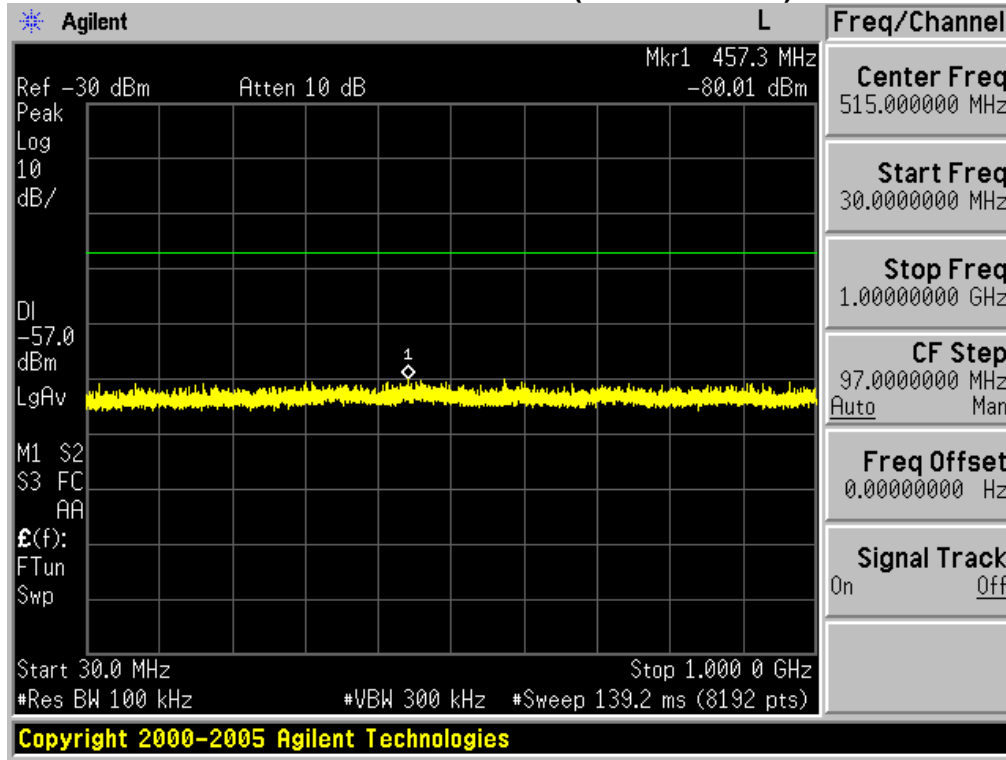

Conducted Measurement (1GHz to 2GHz)

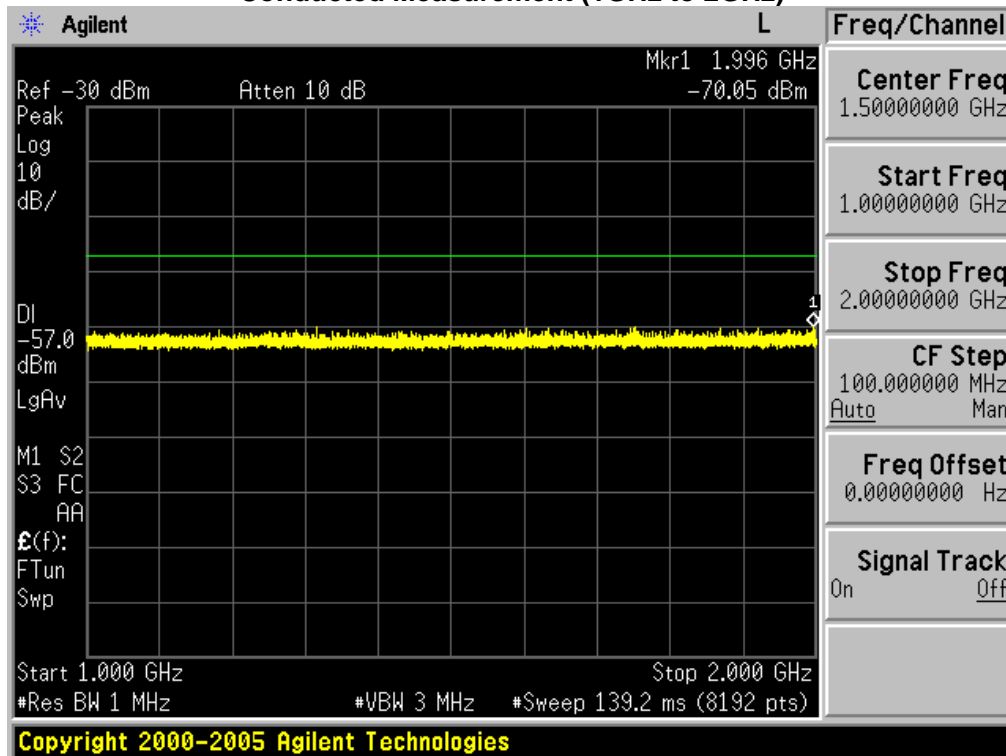

PASS

10. SANNING RECEIVERS AND FREQUENCY CONVERTERS USED WITH SANNING RECEIVERS.

LIMIT

Except as provided in paragraph (c) of this section, scanning receivers shall reject any signals from the Cellular Radiotelephone Service frequency bands that are 38 dB or lower based upon a 12 dB SINAD measurement, which is considered the threshold where a signal can be clearly discerned from any interference that may be present.

TEST CONFIGURATION

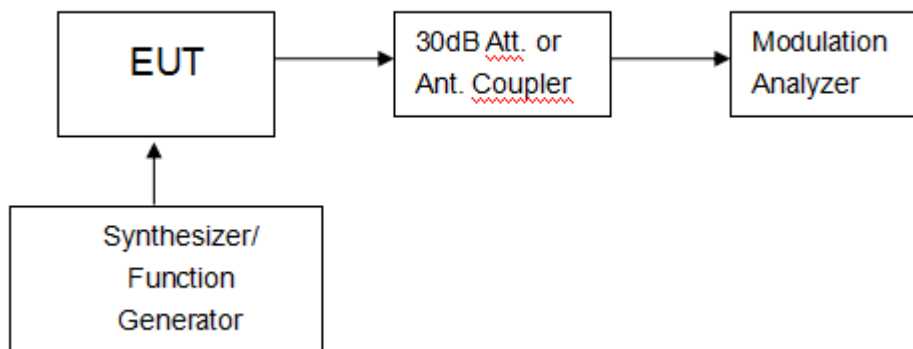

TEST PROCEDURE

Please review the FCC Part 15.121 b section requirements to meet the testing process

TEST RESULTS

Frequency Range(MHz)	Channel	Measurement Result (dB)	Limit(dB)	Result
50.000-53.995	Bottom	44	> 38	Pass
50.000-53.995	Middle	47	> 38	Pass
50.000-53.995	Top	49	> 38	Pass

Note:1.This device meets the requirements of FCC PART 15.121.b

2.The test report only shows the worst test results

APPENDIX 1 PHOTOGRAPHS OF TEST SETUP
CONDUCTED EMISSION TEST SETUP



RADIATED EMISSION TEST SETUP-BELOW 1GHZ

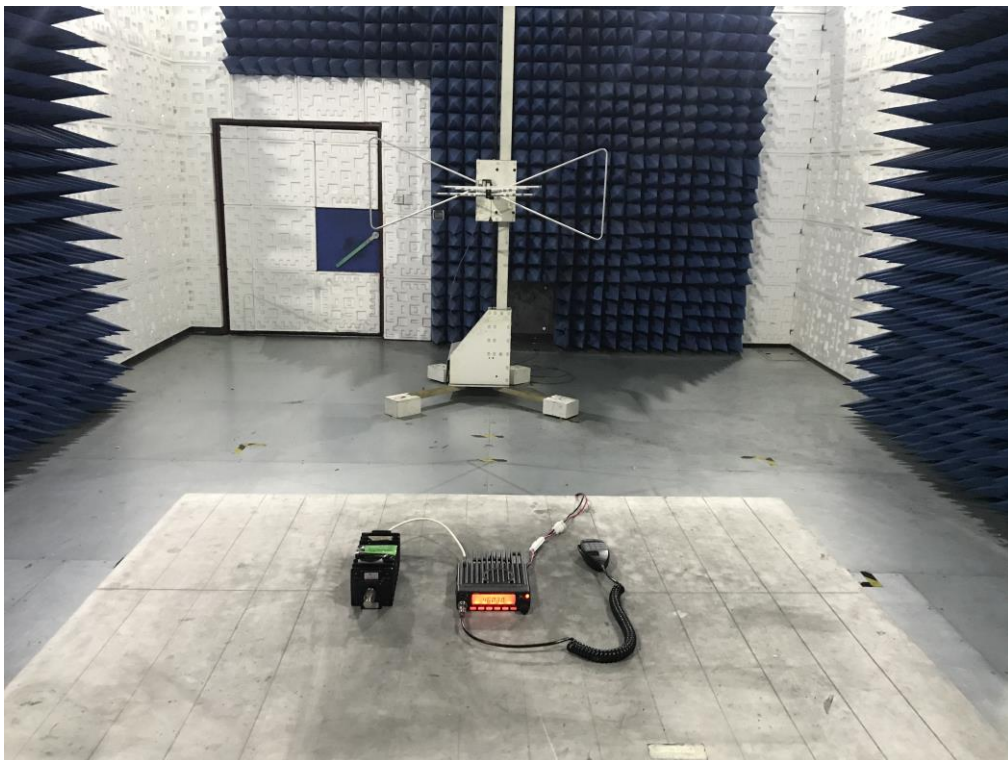

RADIATED EMISSION TEST SETUP-ABOVE 1GHZ

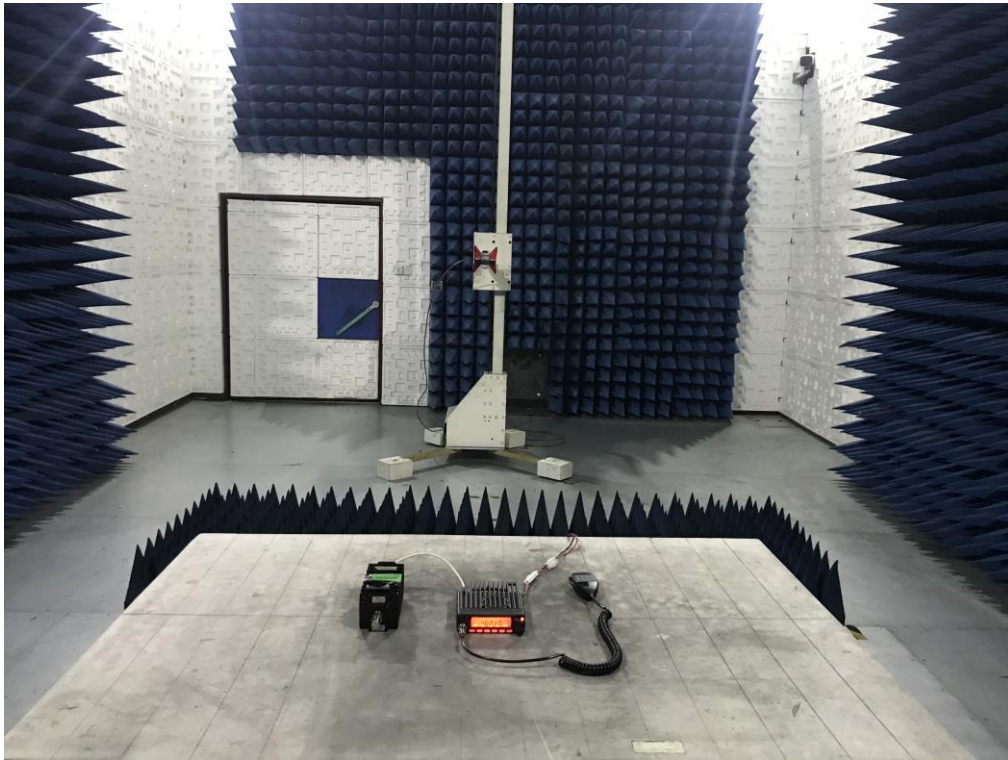

----END OF REPORT----