



Engineering and Testing for EMC and Safety Compliance

CERTIFICATION APPLICATION TEST REPORT

VHF FM TRANSCEIVER

FCC ID: PH3DJ-V47T

IC: 3070C-DJV47T

MODEL: DJ-V47T

Alinco Incorporated
Electronics Division
Shin-Dai Building 9F
2-6, 1-Chome, Dojimahama, Kita-ku
Osaka 530-0004 Japan

October 10, 2006

Standards Referenced for this Report	
Part 2: 2006	Frequency Allocations and Radio Treaty Matters; General Rules and Regulations
Part 15.121: 2006	Radio Frequency Devices; Scanning Receivers and Frequency Converters Used with Scanning Receivers
ANSI C63.4-2003	Standard Format Measurement/Technical Report Personal Computer and Peripherals
RSS-215; Issue 1 (Provisional)	Analogue Scanner Receivers

Frequency Range (MHz)	Output Power (W)	Frequency Tolerance	Emission Designator
400-479.995	N/A	N/A	N/A

REPORT PREPARED BY:

Test Engineer: Daniel Baltzell
Administrative Writer: Daniel Baltzell

Rhein Tech Laboratories, Inc.

Document Number: 2006162

*This report may not be reproduced, except in full, without the full written approval of Rhein Tech Laboratories, Inc.
The test results relate only to the EUT tested.*

Table of Contents

1	General Information	4
1.1	Modifications.....	4
1.2	Related Submittal(s)/Grant(s).....	4
1.3	Test Methodology.....	4
1.4	Test Facility.....	4
2	System Test Configuration.....	5
2.1	Justification.....	5
2.2	Exercising the EUT.....	5
2.3	Test System Details.....	5
2.4	Configuration of Tested System.....	7
3	AC Conducted Emissions - FCC Rules and Regulations Part 15 §15.107(b): Conducted Limits	8
3.1	Site and Test Description.....	8
3.2	Test Limits.....	8
3.3	Conducted Emissions Test Data.....	9
4	Radiated Emissions – FCC Rules and Regulations Part 15 §15.109(a): Radiated Emissions Limits; RSS-215 Section 7 - Receiver Spurious Emissions	10
4.1	Test Methodology for Radiated Emissions Measurements.....	10
4.2	Radiated Emissions Data.....	11
5	FCC Rules and Regulations Part 15 §15.121(b) - 38 dB Rejection Test	12
5.1	38 dB Rejection Test Data for Base Band (869.040-893.970 MHz).....	13
5.2	38 dB Rejection Test Data for Mobile Band (824.040-848.970 MHz).....	13
6	Conclusion.....	14

Table Index

Table 2-1:	Equipment Under Test (EUT).....	6
Table 3-1:	Conducted Emissions Test Data – Mode RX, Neutral Side Line 1, 440 MHz	9
Table 3-2:	Conducted Emissions Test Data – Mode RX, Hot Side Line 2, 440 MHz	9
Table 3-3:	Equipment Used for Testing.....	9
Table 4-1:	Radiated Emissions – Mode RX.....	11
Table 4-2:	Equipment Used for Testing.....	11
Table 5-1:	38 dB Rejection {Frequency Injected: 869.040 MHz} (Cellular Band)	13
Table 5-2:	38 dB Rejection {Frequency Injected: 881.500 MHz} (Cellular Band)	13
Table 5-3:	38 dB Rejection {Frequency Injected: 893.970 MHz} (Cellular Band)	13
Table 5-4:	38 dB Rejection {Frequency Injected: 824.040 MHz} (Mobile Band).....	13
Table 5-5:	38 dB Rejection {Frequency Injected: 836.500 MHz} (Mobile Band).....	13
Table 5-6:	38 dB Rejection {Frequency Injected: 848.970 MHz} (Mobile Band).....	13
Table 5-7:	Equipment Used for Testing.....	14

Appendix Index

Appendix A:	Agency Authorization Letter	15
Appendix B:	Confidentiality Request Letter	16
Appendix C:	FCC Attestation Letter.....	17
Appendix D:	RSS-215 Attestation Letter.....	18
Appendix E:	IC Agent Authority and Listing Requirements Letters.....	19
Appendix F:	Label & Location	20
Appendix G:	Product Description	22
Appendix H:	Block Diagram.....	23
Appendix I:	Schematics.....	24
Appendix J:	Manual	25
Appendix K:	Test Configuration Photographs.....	26
Appendix L:	External Photographs.....	31
Appendix M:	Internal Photographs.....	41

Photograph Index

Photograph 1:	FCC/IC ID and Warning Label locations	20
Photograph 2:	FCC/IC ID Label Sample and Warning Label Sample	21
Photograph 3:	Radiated Emissions Test Configuration (Front View)	26
Photograph 4:	Radiated Emissions Test Configuration (Rear View)	27
Photograph 5:	38 dB Rejection Test Configuration	28
Photograph 6:	Conducted AC Emissions Test Configuration (Front View)	29
Photograph 7:	Conducted AC Emissions Test Configuration (Rear View)	30
Photograph 8:	Front View	31
Photograph 9:	Back View.....	32
Photograph 10:	Right Side View	33
Photograph 11:	Left Side View.....	34
Photograph 12:	Top View.....	35
Photograph 13:	Bottom View	36
Photograph 14:	EDC-146 AC Adapter Top View	37
Photograph 15:	EBP-63, EBP-65, EBP-66 Battery Labels.....	38
Photograph 16:	EDH-34, EBP-64 Battery Labels.....	39
Photograph 17:	Antenna	40
Photograph 18:	Inside Front Cover and PCB in Back Case.....	41
Photograph 19:	Inside Back Cover	42
Photograph 20:	Front PCB with LCD	43
Photograph 21:	Front PCB with LCD Removed.....	44
Photograph 22:	Back PCB with Shield.....	45
Photograph 23:	Back PCB with Shield Removed.....	46

1 General Information

The following application for certification of an analog scanning receiver is prepared on behalf of Alinco Incorporated; Electronics Division, in accordance with FCC Rules and Regulations Parts 2 and 15 and Industry Canada RSS-215. The Equipment Under Test (EUT) is Model DJ-V47T, FCC ID: PH3DJ-V47T. The test results reported in this document relate only to the item that was tested.

All measurements contained in this application were conducted in accordance with ANSI C63.4 Methods of Measurement of Radio Noise Emissions, 2003. The instrumentation utilized for the measurements conforms to the ANSI C63.4 standard for EMI and Field Strength Instrumentation. Some accessories are used to increase sensitivity and prevent overloading of the measuring instrument. Calibration checks are performed regularly on the instruments, and all accessories including the high pass filter, preamplifier and cables.

1.1 Modifications

No modifications were made during testing.

1.2 Related Submittal(s)/Grant(s)

This is an original certification submission.

1.3 Test Methodology

Radiated testing was performed according to the procedures in ANSI C63.4 2003. Radiated testing was performed at an antenna-to-EUT distance of 3 meters.

1.4 Test Facility

The open area test site and conducted measurement facility used to collect the radiated data is located on the parking lot of Rhein Tech Laboratories, 360 Herndon Parkway, Suite 1400, Herndon, Virginia 20170. This site has been fully described in a report, submitted to, and approved by the Federal Communications Commission; to perform AC line conducted and radiated emissions testing (ANSI C63.4 2003).

2 System Test Configuration

2.1 Justification

To complete the test configuration required by the FCC, the receiver was connected to an external antenna, which receives a signal from a signal generator output. With the antenna installed, the receiver indicator was used to determine optimal reception. The EUT's intermediate frequencies (IF), local oscillators (LO), crystal oscillators, and harmonics of each were investigated. Conducted emissions were measured from the AC port of the charger. All modes were investigated and tested, including standby mode and scanning mode. The final radiated data was taken with the EUT locked to a set frequency.

2.2 Exercising the EUT

The DJ-V47T is a VHF FM transceiver designed to function at the following frequency range: 400-479.995 MHz. The following frequencies were tested: 400.000, 440.000, and 479.995 MHz. In order to activate the receiver circuitry, a signal was transmitted from a signal generator. This allowed the EUT to function in its typical state throughout the course of all testing.

2.3 Test System Details

The test sample was received on October 6, 2006. The FCC Identifiers for all equipment, plus descriptions of all cables used in the tested system, are shown in the table below.

Table 2-1: Equipment Under Test (EUT)

Part	Manufacturer	Model	Serial Number	FCC ID	Cable Description	RTL Bar Code
VHF FM Mobile Scanning Receiver	Alinco	DJ-V47T	M000402	PH3DJ-V47T	N/A	17522
VHF FM Mobile Scanning Receiver	Alinco	DJ-V47T	M000401	PH3DJ-V47T	N/A	17520
12VDC Charger	Alinco	EDC-143	M000501	N/A	N/A	17097
AC Adapter	Alinco	EDC-146	N/A	N/A	1.9 m unshielded power	17001
Li-ion Rechargeable Battery	Alinco	EBP-63	N/A	N/A	N/A	17006
Li-ion Rechargeable Battery	Alinco	EBP-64	N/A	N/A	N/A	17007
Ni-MH Rechargeable Battery	Alinco	EBP-65	N/A	N/A	N/A	17528
Ni-MH Rechargeable Battery	Alinco	EBP-65	N/A	N/A	N/A	17529
Ni-MH Rechargeable Battery	Alinco	EBP-65	N/A	N/A	N/A	17530
Ni-MH Rechargeable Battery	Alinco	EBP-65	N/A	N/A	N/A	17531
Ni-MH Rechargeable Battery	Alinco	EBP-65	N/A	N/A	N/A	17532
Ni-MH Rechargeable Battery	Alinco	EBP-66	N/A	N/A	N/A	17009
Battery Case	Alinco	EDH-34	N/A	N/A	N/A	17533
Antenna	Alinco	EA0143	N/A	N/A	N/A	17521
Antenna	Alinco	EA0143	N/A	N/A	N/A	17523
Speaker Microphone	Alinco	EMS-62	N/A	N/A	N/A	17534
Belt Clip	Alinco	N/A	N/A	N/A	N/A	17535
Belt Clip	Alinco	N/A	N/A	N/A	N/A	17536

2.4 Configuration of Tested System

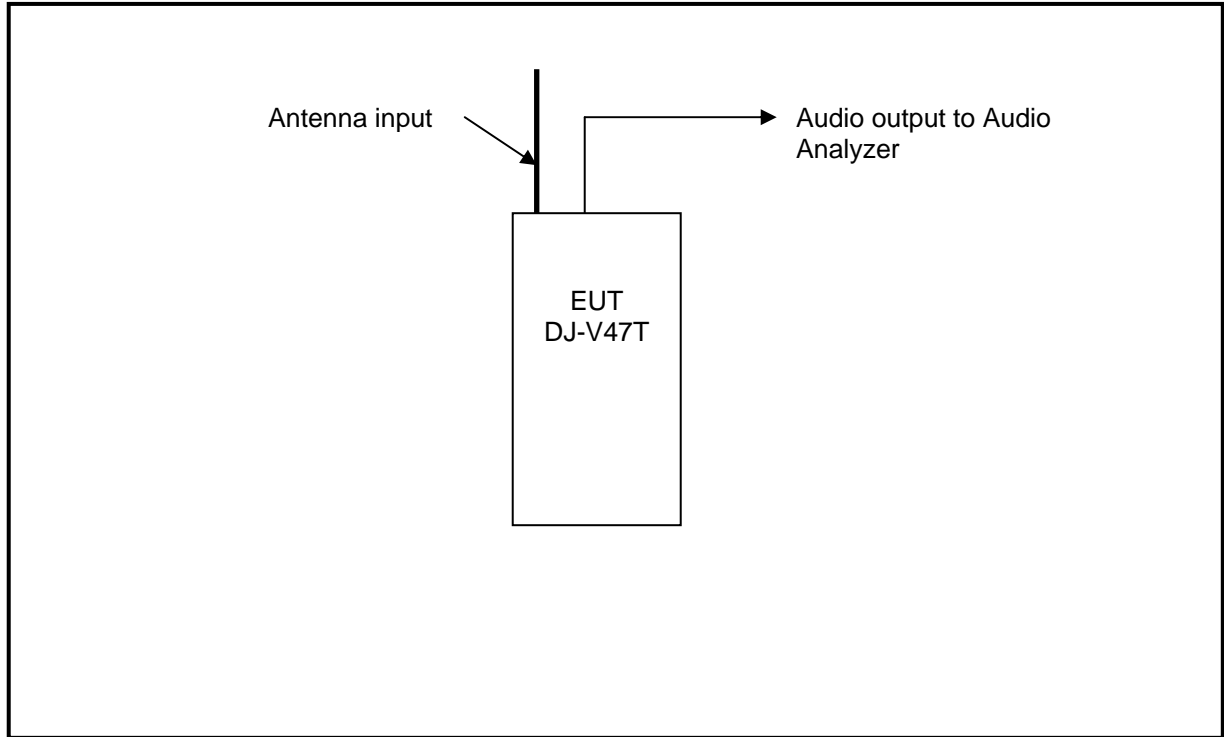

3 AC Conducted Emissions - FCC Rules and Regulations Part 15 §15.107(b): Conducted Limits

3.1 Site and Test Description

The power line conducted emissions measurements were performed in a Series 81 type shielded enclosure manufactured by Rayproof. The EUT was assembled on a wooden table 80 centimeters high. Power was fed to the EUT through a 50-ohm/50 microhenry Line Impedance Stabilization Network (LISN). The EUT LISN was fed power through an A.C. filter box on the outside of the shielded enclosure. The filter box and EUT LISN housing are bonded to the ground plane of the shielded enclosure. A second LISN, the peripheral LISN, provides isolation for the EUT test peripherals. This peripheral LISN was also fed A.C. power. A metal power outlet box, which is bonded to the ground plane and electrically connected to the peripheral LISN, powers the EUT host peripherals.

The spectrum analyzer was connected to the A.C. line through an isolation transformer. The 50-ohm output of the EUT LISN was connected to the spectrum analyzer input through a Solar 100 kHz high-pass filter. The filter is used to prevent overload of the spectrum analyzer from noise below 100 kHz. Conducted emission levels were measured on each current-carrying line with the spectrum analyzer operating in the CISPR quasi-peak mode (or peak mode if applicable).

The analyzer's 6 dB bandwidth was set to 9 kHz. Video filter less than 10 times the resolution bandwidth is not used. Average measurements are performed in linear mode using a 10 kHz resolution bandwidth, a 1 Hz video bandwidth, and by increasing the sweep time in order to obtain a calibrated measurement. The emission spectrum was scanned from 150 kHz to 30 MHz. The highest emission amplitudes relative to the appropriate limits were measured and have been recorded.

Conducted measurements at telecommunications ports (if applicable) were performed per EN55022: 1998. The limits for Class A and Class B are contained therein.

3.2 Test Limits

Class A Line-Conducted Emissions		
Limit (dBµV)		
Frequency (MHz)	Quasi-Peak	Average
0.15 to 0.50	79	66
0.50 to 30.0	73	60

Class B Line-Conducted Emissions		
Limit (dBµV)		
Frequency (MHz)	Quasi-Peak	Average
0.15 to 0.50	66 to 56	56 to 46
0.50 to 5.00	56	46
5.00 to 30.00	60	50

3.3 Conducted Emissions Test Data

Table 3-1: Conducted Emissions Test Data – Mode RX, Neutral Side Line 1, 440 MHz

Temperature: 74°F Humidity: 83%									
Emission Frequency (MHz)	Test Detector	Analyzer Reading (dBuV)	Site Correction Factor (dB)	Emission Level (dBuV)	FCC B QP Limit (dBuV)	FCC B QP Margin (dBuV)	FCC B AV Limit (dBuV)	FCC B AV Margin (dBuV)	Pass/Fail
0.160	Pk	41.4	0.4	41.8	65.5	-23.7	55.5	-13.7	Pass
0.417	Pk	39.9	0.4	40.3	57.5	-17.2	47.5	-7.2	Pass
0.626	Pk	29.5	0.4	29.9	56.0	-26.1	46.0	-16.1	Pass
1.229	Pk	22.2	0.7	22.9	56.0	-33.1	46.0	-23.1	Pass
7.570	Pk	17.3	2.0	19.3	60.0	-40.7	50.0	-30.7	Pass
21.150	Pk	15.7	3.2	18.9	60.0	-41.1	50.0	-31.1	Pass

Table 3-2: Conducted Emissions Test Data – Mode RX, Hot Side Line 2, 440 MHz

Temperature: 74°F Humidity: 83%									
Emission Frequency (MHz)	Test Detector	Analyzer Reading (dBuV)	Site Correction Factor (dB)	Emission Level (dBuV)	FCC B QP Limit (dBuV)	FCC B QP Margin (dBuV)	FCC B AV Limit (dBuV)	FCC B AV Margin (dBuV)	Pass/Fail
0.154	Pk	41.1	0.4	41.5	65.8	-24.3	55.8	-14.3	Pass
0.418	Pk	40.4	0.4	40.8	57.5	-16.7	47.5	-6.7	Pass
0.506	Pk	31.6	0.4	32.0	56.0	-24.0	46.0	-14.0	Pass
0.721	Pk	29.0	0.4	29.4	56.0	-26.6	46.0	-16.6	Pass
5.140	Pk	17.1	2.0	19.1	60.0	-40.9	50.0	-30.9	Pass
18.800	Pk	17.2	3.2	20.4	60.0	-39.6	50.0	-29.6	Pass

Table 3-3: Equipment Used for Testing

RTL Asset #	Manufacturer	Model	Part Type	Serial Number	Calibration Date
900969	Hewlett Packard	85650A	Quasi-Peak Adapter (30 Hz – 40 GHz)	2412A00414	9/13/07
900931	Hewlett Packard	8566B	Spectrum Analyzer (100 Hz – 22 GHz)	3138A07771	9/13/07
900930	Hewlett Packard	85662A	Spectrum Analyzer Display	3144A20839	9/13/07
901083	AFJ	LS16	16A LISN	16010020082	3/29/07

Test Personnel:

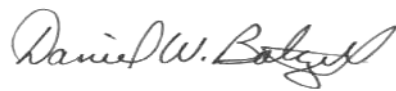

Signature: _____ Typed Name: Daniel Baltzell Date: October 9, 2006

4 Radiated Emissions – FCC Rules and Regulations Part 15 §15.109(a): Radiated Emissions Limits; RSS-215 Section 7 - Receiver Spurious Emissions

4.1 Test Methodology for Radiated Emissions Measurements

Before final measurements of radiated emissions were made on the open-field three/ten meter range, the EUT was scanned indoors at one meter and three meter distances, in order to determine its emissions spectrum signature. The physical arrangement of the test system and associated cabling was varied in order to determine the effect on the EUT's emissions in amplitude, direction, and frequency. This process was repeated during final radiated emissions measurements on the open-field range, at each frequency, in order to ensure that maximum emission amplitudes were attained.

Final radiated emissions measurements were made on the three meter, open-field test site. The EUT was placed on a nonconductive turntable approximately 80 centimeters above the ground plane. The spectrum was examined from 30 MHz to 1000 MHz using a spectrum analyzer, a quasi-peak adapter, and EMCO log periodic and biconical antenna. In order to gain sensitivity, a preamplifier was connected in series between the antenna and the input of the spectrum analyzer.

At each frequency, the EUT was rotated 360 degrees, and the antenna was raised and lowered from one to four meters in order to determine the maximum emission levels. Measurements were taken using both horizontal and vertical antenna polarizations. The spectrum analyzer's 6 dB bandwidth was set to 120 kHz, and the analyzer was operated in the CISPR quasi-peak detection mode. No video filter less than 10 times the resolution bandwidth was used. The second harmonic of the highest LO was tested. The highest emission amplitudes relative to the appropriate limit were measured and recorded in this report.

Note: Rhein Tech Laboratories, Inc. has implemented procedures to minimize errors that occur from test instruments, calibration, procedures, and test setups. Test instrument and calibration errors are documented from the manufacturer or calibration lab. Other errors have been defined and calculated within the Rhein Tech Quality Manual, Section 6.1. Rhein Tech implements the following procedures to minimize errors that may occur: yearly as well as daily calibration methods, technician training, and emphasis to employees on avoiding error.

4.2 Radiated Emissions Data

Table 4-1: Radiated Emissions – Mode RX

Temperature: 50°F Humidity: 90%									
Emission Frequency (MHz)	Test Detector	Antenna Polarity (H/V)	Turntable Azimuth (deg)	Antenna Height (m)	Analyzer Reading (dBuV)	Site Correction Factor (dB/m)	Emission Level (dBuV/m)	Limit (dBuV/m)	Margin (dB)
72.430	Qp	H	0	1.0	33.5	-22.6	10.9	40.0	-29.1
96.575	Qp	H	0	1.0	32.2	-18.3	13.9	43.5	-29.6
144.815	Qp	H	0	1.0	32.2	-16.8	15.4	43.5	-28.1
193.150	Qp	H	0	1.0	35.4	-18.1	17.3	43.5	-26.2
802.299	Qp	H	30	1.5	42.1	-3.1	39.0	46.0	-7.0
1604.597	Av	H	0	1.5	35.6	6.9	42.5	54.0	-11.5

Notes: All readings are quasi-peak, unless stated otherwise.
 A low, middle, and high channel was checked for every frequency band.
 Limit/Distance: FCC B/3M

Table 4-2: Equipment Used for Testing

RTL Asset #	Manufacturer	Model	Part Type	Serial Number	Calibration Date
900931	Hewlett Packard	8566B	Spectrum Analyzer (100 Hz - 22 GHz)	3138A07771	9/13/07
900930	Hewlett Packard	85662A	Spectrum Analyzer Display Section	3144A20839	9/13/07
901053	Schaffner & Chase	CBL6112B	Bilog Antenna (20 MHz - 2 GHz)	2648	11/1/06
901281	Rhein Tech Laboratories, Inc.	PR-1040	Pre Amplifier 40 dB (10 MHz - 2 GHz)	1006	12/8/06
900969	Hewlett Packard	85650A	Quasi-Peak Adapter	2412A00414	9/13/07

Test Personnel:

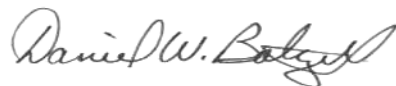

Signature: _____ Typed Name: Daniel Baltzell Date: October 9, 2006

5 FCC Rules and Regulations Part 15 §15.121(b) - 38 dB Rejection Test

A signal generator was connected to the receiver under test, and the output of the receiver was connected to an audio analyzer.

An FM signal was applied to the receiver antenna input with a 1 kHz tone modulated at 8 kHz deviation, and adjusted with the audio analyzer to produce a 12 dB SINAD. This was done across the receiver bands to determine a reference level. The reference level used was that with the highest sensitivity in all of the bands.

The output of the signal generator was then adjusted to a level 40 dB above the reference level established, and set to a low, medium, and high frequency in both the mobile and base cellular bands: the mobile band being 824.04 MHz - 848.97 MHz, and the base band being 869.04 MHz - 893.97 MHz. The squelch of the receiver was then set to a minimum threshold level, and scanning begun from the lowest to the highest channel. Whenever the receiver stopped and “un-squelched”, that frequency was noted as a response. After all the frequencies of responses were noted, the signal generator was set to measure the sensitivity at each of these response frequencies. This measurement was the reference sensitivity for the particular received frequency measured. The audio analyzer measurement was used to measure the 12 dB SINAD, which is the spurious value. The difference between the reference sensitivity and the spurious value is the rejection ratio and must be at least 38 dB.

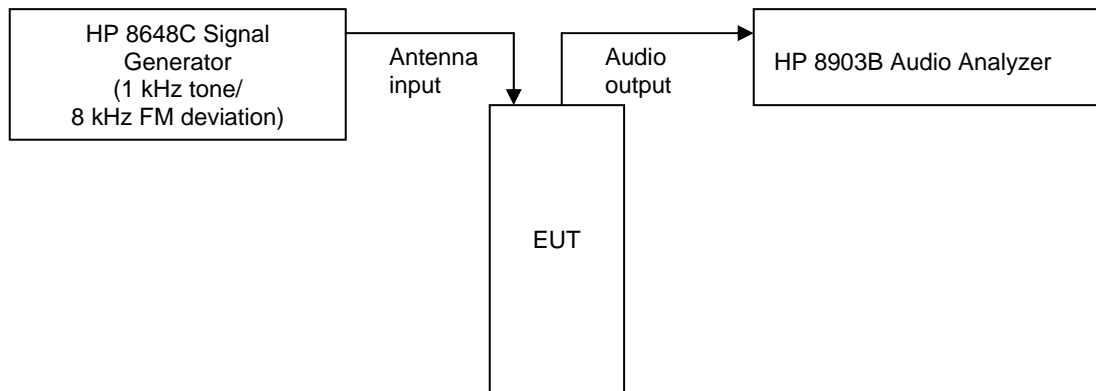

Frequencies used on the signal generator were 824.04, 836.50, and 848.97 MHz for the mobile band, and 869.04, 881.50, and 893.97 MHz for the base band.

The DJ-V47T unit reference level used was -63.9 dBm from the signal generator. The DJ-V47T unit was scanned on all specified operating frequency ranges, per manufacturer's specifications. Signals that were noted as responses were checked with the signal generator off. If they were still present, they were determined to be ambient signals and removed from the response list.

No signals were detected for the 38 dB rejection test requirements.

5.1 38 dB Rejection Test Data for Base Band (869.040-893.970 MHz)

Table 5-1: 38 dB Rejection {Frequency Injected: 869.040 MHz} (Cellular Band)

Frequency Injected: 869.040 MHz		Temperature: 74°F; Humidity: 88%		
Frequency Detected (MHz)	Level 12 dB SINAD at 869.040 MHz	Level 12 dB at Frequency Detected	Rejection	Margin
No Frequencies Detected	N/A	N/A	N/A	N/A

Table 5-2: 38 dB Rejection {Frequency Injected: 881.500 MHz} (Cellular Band)

Frequency Injected: 881.500 MHz		Temperature: 74°F; Humidity: 88%		
Frequency Detected (MHz)	Level 12 dB SINAD at 881.500 MHz	Level 12 dB at Frequency Detected	Rejection	Margin
No Frequencies Detected	N/A	N/A	N/A	N/A

Table 5-3: 38 dB Rejection {Frequency Injected: 893.970 MHz} (Cellular Band)

Frequency Injected: 893.970 MHz		Temperature: 74°F; Humidity: 88%		
Frequency Detected (MHz)	Level 12 dB SINAD at 893.970 MHz	Level 12 dB at Frequency Detected	Rejection	Margin
No Frequencies Detected	N/A	N/A	N/A	N/A

5.2 38 dB Rejection Test Data for Mobile Band (824.040-848.970 MHz)

Table 5-4: 38 dB Rejection {Frequency Injected: 824.040 MHz} (Mobile Band)

Frequency Injected: 824.040 MHz		Temperature: 74°F; Humidity: 88%		
Frequency Detected (MHz)	Level 12 dB SINAD at 824.040 MHz	Level 12 dB at Frequency Detected	Rejection	Margin
No Frequencies Detected	N/A	N/A	N/A	N/A

Table 5-5: 38 dB Rejection {Frequency Injected: 836.500 MHz} (Mobile Band)

Frequency Injected: 836.500 MHz		Temperature: 74°F; Humidity: 88%		
Frequency Detected (MHz)	Level 12 dB SINAD at 836.500 MHz	Level 12 dB at Frequency Detected	Rejection	Margin
No Frequencies Detected	N/A	N/A	N/A	N/A

Table 5-6: 38 dB Rejection {Frequency Injected: 848.970 MHz} (Mobile Band)

Frequency Injected: 848.970 MHz		Temperature: 74°F; Humidity: 88%		
Frequency Detected (MHz)	Level 12 dB SINAD at 848.970 MHz	Level 12 dB at Frequency Detected	Rejection	Margin
No Frequencies Detected	N/A	N/A	N/A	N/A

Table 5-7: Equipment Used for Testing

RTL Asset #	Manufacturer	Model	Part Type	Serial Number	Calibration Date
900917	Hewlett Packard	8648C	Signal Generator, 100 KHz-3.2 GHz	3537A01741	8/29/07
901067	Hewlett Packard	HP8903B	Audio Analyzer	2450A00135	7/21/07

Test Personnel:



Signature: _____ Typed Name: Daniel Baltzell Date: October 6, 2006

6 Conclusion

The data in this measurement report shows that the Alinco Incorporated Model DJ-V47T, FCC ID: **PH3DJ-V47T**, IC: **3070C-DJV47T**, complies with all applicable requirements of Parts 2 and 15.121 of the FCC Rules and Industry Canada RSS-215, Issue 1.