



FCC Part 90& RSS-119 Test Report

Report No.: AGC00589140301FE09

FCC ID : PH3DJ-A41
IC ID : 3070C-DJA41
PRODUCT DESIGNATION : UHF FM HANDHELD TRANSCEIVER
BRAND NAME : ALINCO
MODEL NAME : DJ-A41
CLIENT : Alinco Incorporated, Electronics Division
DATE OF ISSUE : May 22, 2014
STANDARD(S) : FCC Part 90& RSS-119 Rules
REPORT VERSION : V 1.0

Attestation of **Global Compliance (Shenzhen) Co., Ltd.**



CAUTION:

This report shall not be reproduced except in full without the written permission of the test laboratory and shall not be quoted out of context.

REPORT REVISE RECORD

Report Version	Revise Time	Issued Date	Valid Version	Notes
V1.0	/	May 22, 2014	Valid	Original Report

VERIFICATION OF COMPLIANCE

Applicant:	Alinco Incorporated, Electronics Division
	Yodoyabashi Dai-Bldg 13F, 4-4-9 Koraibashi, Chuo-Ku, Osaka 541-0043, Japan
Manufacturer:	Alinco Incorporated, Electronics Division
	Yodoyabashi Dai-Bldg 13F, 4-4-9 Koraibashi, Chuo-Ku, Osaka 541-0043, Japan
Product Designation:	UHF FM HANDHELD TRANSCEIVER
Brand Name:	ALINCO
Model Name:	DJ-A41
Hardware Version:	V1.00
Software Version:	V2.02
Date of Test:	Mar.27,2014 to May 08, 2014

We hereby certify that:

The above equipment was tested by Attestation of Global Compliance (Shenzhen) Co., Ltd. The data evaluation, test procedures, and equipment configurations shown in this report were made in accordance with the procedures given in ANSI C 63.4:2003 and TIA/EIA 603. The sample tested as described in this report is in compliance with the FCC Rules Part 90 and RS-119 requirements

The test results of this report relate only to the tested sample identified in this report.

Tested By : 

Bart Xie May 22, 2014

Reviewed By : 

Kidd Yang May 22, 2014

Approved By: 

Solger Zhang May 22, 2014

TABLE OF CONTENTS

TABLE OF CONTENTS	4
1. GENERAL INFORMATION	7
1.1 PRODUCT DESCRIPTION	7
1.2 RELATED SUBMITTAL(S) / GRANT (S)	8
1.3 TEST METHODOLOGY	8
1.4 TEST FACILITY	8
1.5 SPECIAL ACCESSORIES.....	8
1.6 EQUIPMENT MODIFICATIONS.....	8
2. SYSTEM TEST CONFIGURATION	9
2.1 EUT CONFIGURATION.....	9
2.2 EUT EXERCISE	9
2.3 GENERAL TECHNICAL REQUIREMENTS	9
2.4 CONFIGURATION OF TESTED SYSTEM	9
3. SUMMARY OF TEST RESULTS	10
4. DESCRIPTION OF TEST MODES	11
5. CONDUCTED LIMITS	12
5.1 PROVISIONS APPLICABLE	12
5.2 MEASUREMENT PROCEDURE.....	12
5.3 TEST SETUP BLOCK DIAGRAM	13
5.4 TEST EQUIPMENT USED	13
5.5 TEST RESULT.....	14
6. FREQUENCY TOLERANCE	16
6.1 PROVISIONS APPLICABLE	16
6.2 MEASUREMENT PROCEDURE.....	16
6.3 TEST SETUP BLOCK DIAGRAM.....	17
6.4 TEST EQUIPMENT USED:	17

6.5 TEST RESULT	17
7. EMISSION BANDWIDTH	20
7.1 PROVISIONS APPLICABLE	20
7.2 MEASUREMENT PROCEDURE.....	20
7.3 TEST SETUP BLOCK DIAGRAM	20
7.4 MEASUREMENT EQUIPMENT USED:	20
7.5 MEASUREMENT RESULT:	21
8. UNWANTED RADIATION	22
8.1 PROVISIONS APPLICABLE	22
8.2 MEASUREMENT PROCEDURE.....	22
8.3 TEST SETUP BLOCK DIAGRAM	23
8.4 MEASUREMENT EQUIPMENT USED:	25
8.5 MEASUREMENT RESULTS:	25
8.6 EMISSION MASK PLOT	27
9. MODULATION CHARACTERISTICS	28
9.1 PROVISIONS APPLICABLE	28
9.2 MEASUREMENT METHOD.....	28
9.3 MEASUREMENT INSTRUMENTS.....	28
9.4 MEASUREMENT RESULT.....	29
10. MAXIMUM TRANSMITTER POWER (CONDUCTED OUTPUT POWER)	32
10.1 PROVISIONS APPLICABLE	32
10.2 TEST PROCEDURE	32
10.3 TEST INSTRUMENTS	32
10.4 TEST CONFIGURATION	32
10.5 TEST RESULT	32
10.4 CONDUCT SPURIOUS PLOT	33
11. TRANSMITTER FREQUENCY BEHAVIOR	35

11.1	PROVISIONS APPLICABLE	35
11.2	TEST METHOD	35
11.3	TEST INSTRUMENTS.....	35
12.	RADIATED EMISSION ON RECEIVING MODE	39
12.1	PROVISIONS APPLICABLE	39
12.2	TEST METHOD	39
12.3	TEST INSTRUMENTS.....	39
12.4	MEASURE RESULT (MEASURED AT 3M USING FCC PART15 B LIMITS)	40
13.	AUDIO LOW PASS FILTER RESPONSE	42
13.1	LIMITS.....	42
13.2.	METHOD OF MEASUREMENTS	42
13.3	TEST DATA	42
APPENDIX I	45
PHOTOGRAPHS OF SETUP	45
APPENDIX II	48
EXTERNAL VIEW OF EUT	48

1. GENERAL INFORMATION

1.1 PRODUCT DESCRIPTION

The EUT is a single channel UHF FM HANDHELD TRANSCEIVER designed for voice communication. It is designed by way of utilizing the FM modulation achieves the system operating.

A major technical description of EUT is described as following:

Communication Type	Voice / Tone only
Modulation	FM
Emission Type	F3E
Emission Bandwidth	10.29kHz
Peak Frequency Deviation	2.78 KHz
Audio Frequency Response	2.67dB
Maximum Transmitter Power	37.15dBm for 12.5 KHz Channel Separation
Output power Modification	5W (It was fixed by the manufacturer, any individual can't arbitrarily change it)
Antenna Designation	Detachable
Power Supply	DC 7.4V by battery
Battery Endpoint	DC 6.29V
Operation Frequency Range and Channel	Frequency Range:400MHz to 470MHz Channel Separation: 12.5KHz
	Top Channel: 469.975MHz, Centre Channel: 435.225MHz, Bottom Channel:400.225MHz,
Frequency Tolerance	0.225ppm for 12.5 KHz Channel Separation

Note: UHF: 400MHz to 470MHz

1.2 RELATED SUBMITTAL(S) / GRANT (S)

This submittal(s) (test report) is intended for **FCC ID: PH3DJ-A41** and **IC ID: 3070C-DJA41**, filing to comply with the FCC Part 90 and RS-119 requirements.

1.3 TEST METHODOLOGY

The radiated emission testing was performed according to the procedures of ANSI C 63.4: 2009; TIA/EIA 603 and FCC CFR 47 Rules of 2.1046, 2.1047, 2.1049, 2.1051, 2.1053, 2.1055, 2.1057.

1.4 TEST FACILITY

The test site used to collect the radiated data is located on the address of Attestation of Global Compliance (Shenzhen) Co., Ltd. 2F., No.2 Building, Huafeng No.1 Technical Industrial Park, Sanwei, Xixiang, Baoan District, Shenzhen. The test site is constructed and calibrated to meet the FCC requirements in documents ANSI C63.4: 2003 and IC requirements in documents RS212.

FCC register No.: 259865

1.5 SPECIAL ACCESSORIES

Not available for this EUT intended for grant.

1.6 EQUIPMENT MODIFICATIONS

Not available for this EUT intended for grant.

2. SYSTEM TEST CONFIGURATION

2.1 EUT CONFIGURATION

The EUT configuration for testing is installed on RF field strength measurement to meet the Commission’s requirement and operating in a manner which intends to maximize its emission characteristics in a continuous normal application.

2.2 EUT EXERCISE

The Transmitter was operated in the normal operating mode. The TX frequency was fixed which was for the purpose of the measurements.

2.3 GENERAL TECHNICAL REQUIREMENTS

- (1). Section 15.207: Conducted Limits
- (2). Section 90.205: Maximum ERP is dependent upon the station’s antenna HAAT and required service area
- (3). Section 90.207: Modulation Characteristic
- (4). Section 90.209: Occupied Bandwidth
- (5). Section 90.210: Emission Mask
- (6). Section 90.213: Frequency Tolerance
- (7). Section 90.214: Transient Frequency Behavior
- (8). Section 15.109: Radiated Emission

2.4 CONFIGURATION OF TESTED SYSTEM

Fig. 2-1 Configuration of Tested System



Table 2-1 Equipment Used in Tested System

Item	Equipment	Model No.	Identifier	Note
1	UHF FM HANDHELD TRANSCEIVER	DJ-A41	FCC ID: PH3DJ-A10 IC ID: 3070C-DJ-A10	EUT
2	Charger	EDC-189	N/A	Accessory
3	Battery	EBP-87	N/A	Accessory

3. SUMMARY OF TEST RESULTS

FCC Rules	RS-119	Description Of Test	Result
§15.207	RS-Gen	Conducted Emission	Compliant
§90.205	§5.4	Maximum Transmitter Power	Compliant
§90.207	§5.13	Modulation Characteristic	Compliant
§90.209	§5.5	Occupied Bandwidth	Compliant
§90.210	§5.8	Emission Mask	Compliant
§90.213	§5.3	Frequency Tolerance	Compliant
§90.214	§5.9	Transient Frequency Behavior	Compliant
§15.109	RS-Gen	Radiated Emission	Compliant

4. DESCRIPTION OF TEST MODES

RF TEST MODES

The EUT (UHF FM HANDHELD TRANSCEIVER) has been tested under normal operating condition. (The top channel, the middle channel and the bottom channel) are chosen for testing at each channel separation (12.5 KHz).

No.	TEST MODES	CHANNEL SEPARATION
1	Low Channel	12.5 KHz
2	Middle Channel	12.5 KHz
3	High Channel	12.5 KHz
4	Standby Mode	12.5 KHz

EMC TEST MODES

No.	TEST MODES
1	Standby Mode + (Charging)

Note: only the result of the worst case was recorded in the report.

5. CONDUCTED LIMITS

5.1 PROVISIONS APPLICABLE

For an intentional radiator that is designed to be connected to the public utility (AC) power line, the, the radio frequency voltage that is conducted back onto the AC power line on any frequencies within the band 150 KHz to 30 MHz shall not exceed the limits in the following table, as measured using a 50uH/50 ohms line impedance stabilization network (LISN). Compliance with the provisions of this paragraph shall be based on the measurement of the radio frequency voltage between each power line and ground at the power terminal. The lower limit applies at the boundary between the frequencies ranges.

Frequency of Emission (MHz)	Conducted Limit(dBuV)	
	Quasi-Peak	Average
0.15 – 0.5	66 to 56 *	56 to 46 *
0.5 – 5	56	46
5 – 30	60	50

* Decreases with the logarithm of the frequency.

5.2 MEASUREMENT PROCEDURE

- (1) The equipment was set up as per the test configuration to simulate typical actual usage per the user's manual. When the EUT is a tabletop system, a wooden table with a height of 0.8 meters is used and is placed on the ground plane as per ANSI C63.4 (see Test Facility for the dimensions of the ground plane used). When the EUT is a floor-standing equipment, it is placed on the ground plane which has a 3-12 mm non-conductive covering to insulate the EUT from the ground plane.
- (2) Support equipment, if needed, was placed as per ANSI C63.4.
- (3) All I/O cables were positioned to simulate typical actual usage as per ANSI C63.4.
- (4) The EUT received AC110V/60Hz power through a Line Impedance Stabilization Network (LISN) which supplied power source and was grounded to the ground plane.
- (5) All support equipments received AC power from a second LISN, if any.
- (6) The EUT test program was started. Emissions were measured on each current carrying line of the EUT using a spectrum Analyzer / Receiver connected to the LISN powering the EUT. The LISN has two monitoring points: Line 1 (Hot Side) and Line 2 (Neutral Side). Two scans were taken: one with Line 1 connected to Analyzer / Receiver and Line 2 connected to a 50 ohm load; the second scan had Line 1 connected to a 50 ohm load and Line 2 connected to the Analyzer / Receiver.
- (7) Analyzer / Receiver scanned from 150 KHz to 30MHz for emissions in each of the test modes.
During the above scans, the emissions were maximized by cable manipulation.

5.3 TEST SETUP BLOCK DIAGRAM

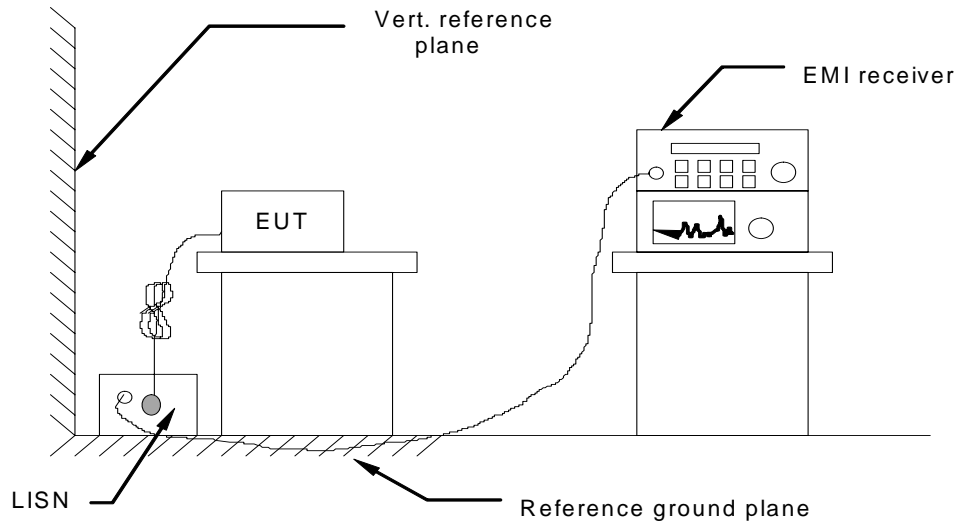

5.4 TEST EQUIPMENT USED

Conducted Emission Test Site					
Name of Equipment	Manufacturer	Model	Serial Number	Cal. Date	Cal. Due
TEST RECEIVER	R&S	ESCI	N/A	07/18/2013	07/17/2014
LISN	R&S	ESH3-Z5	N/A	07/18/2013	07/17/2014

5.5 TEST RESULT

LINE CONDUCTED EMISSION TEST-L

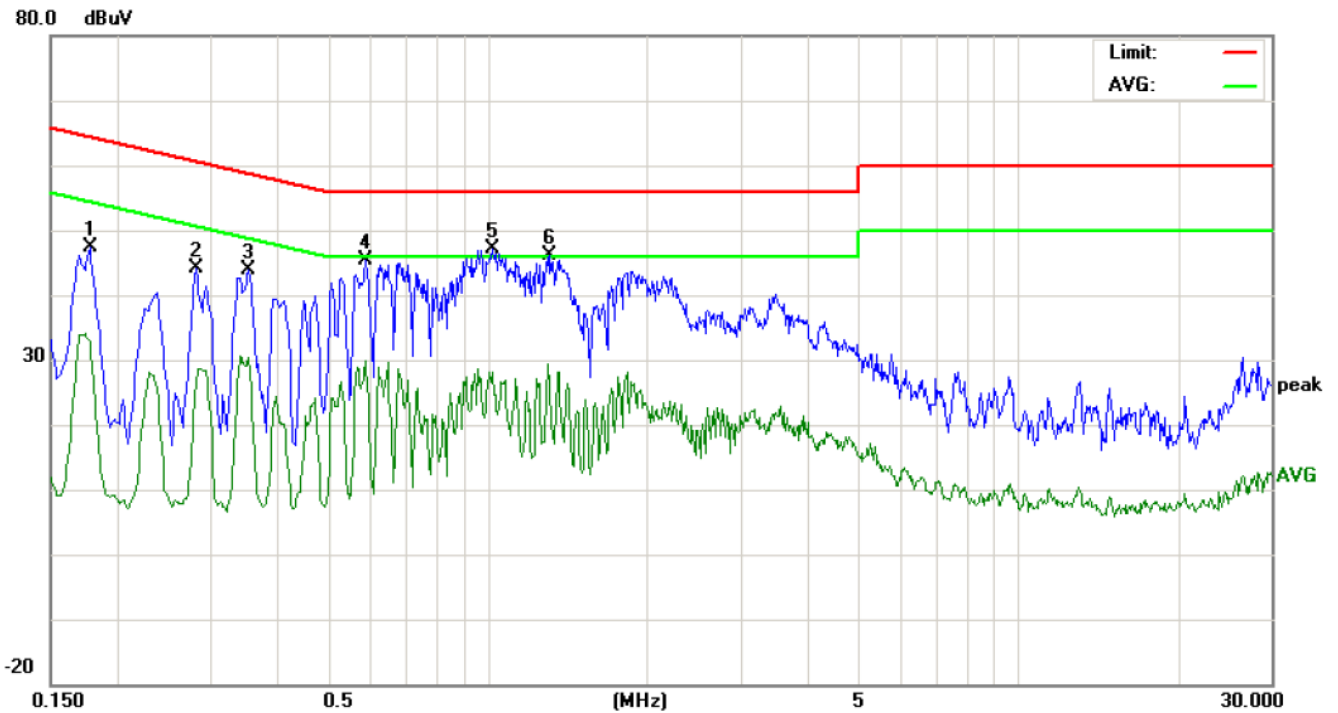

Site: Conduction
 Limit: FCC Class B Conduction(QP)
 EUT: UHF FM HANDHELD TRANSCEIVER
 M/N: DJ-A41
 Mode: Mode 1
 Note:

Phase: **L1**
 Power: AC 120V/60Hz

Temperature: 26
 Humidity: 60 %

No.	Freq. (MHz)	Reading_Level (dBuV)			Correct Factor (dB)	Measurement (dBuV)			Limit (dBuV)		Margin (dB)		P/F	Comment
		Peak	QP	AVG		Peak	QP	AVG	QP	AVG	QP	AVG		
1	0.1780	37.18		22.58	10.19	47.37		32.77	64.57	54.57	-17.20	-21.80	P	
2	0.2819	33.88		16.79	10.28	44.16		27.07	60.76	50.76	-16.60	-23.69	P	
3	0.3540	33.54		20.03	10.31	43.85		30.34	58.87	48.87	-15.02	-18.53	P	
4	0.5899	35.07		19.66	10.32	45.39		29.98	56.00	46.00	-10.61	-16.02	P	
5	1.0220	36.79		17.73	10.37	47.16		28.10	56.00	46.00	-8.84	-17.90	P	
6	1.3099	35.69		15.48	10.38	46.07		25.86	56.00	46.00	-9.93	-20.14	P	

LINE CONDUCTED EMISSION TEST-N

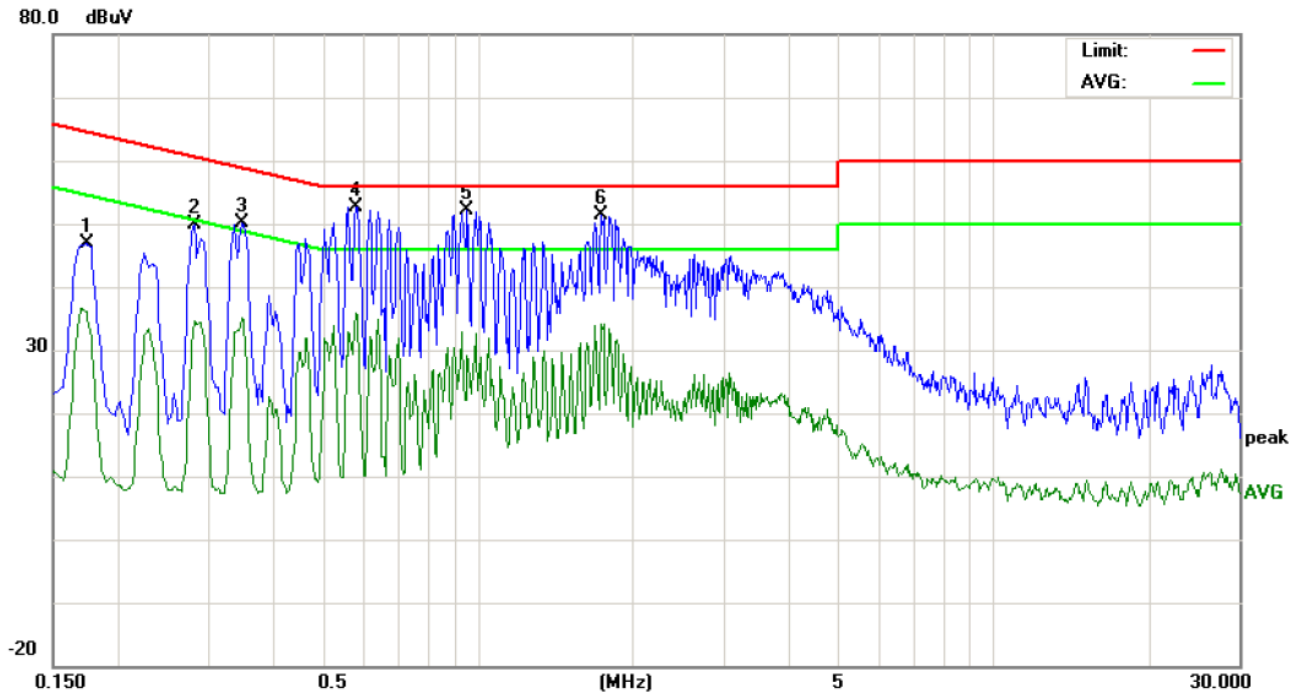

Site: Conduction Phase: **N** Temperature: 26
 Limit: FCC Class B Conduction(QP) Power: AC 120V/60Hz Humidity: 60 %
 EUT: UHF FM HANDHELD TRANSCEIVER
 M/N: DJ-A41
 Mode: Mode 1
 Note:

No.	Freq. (MHz)	Reading_Level (dBuV)			Correct Factor (dB)	Measurement (dBuV)			Limit (dBuV)		Margin (dB)		P/F	Comment
		Peak	QP	AVG		Peak	QP	AVG	QP	AVG	QP	AVG		
1	0.1740	36.70		25.86	10.19	46.89		36.05	64.76	54.76	-17.87	-18.71	P	
2	0.2819	39.70		24.22	10.28	49.98		34.50	60.76	50.76	-10.78	-16.26	P	
3	0.3500	39.82		24.72	10.31	50.13		35.03	58.96	48.96	-8.83	-13.93	P	
4	0.5820	42.39		25.48	10.33	52.72		35.81	56.00	46.00	-3.28	-10.19	P	
5	0.9580	41.66		18.61	10.39	52.05		29.00	56.00	46.00	-3.95	-17.00	P	
6	1.7420	41.20		23.71	10.30	51.50		34.01	56.00	46.00	-4.50	-11.99	P	

6. FREQUENCY TOLERANCE

6.1 PROVISIONS APPLICABLE

- a). According to FCC Part 2 Section 2.1055(a)(1), the frequency stability shall be measured with variation of ambient temperature from -30°C to $+50^{\circ}\text{C}$ centigrade.
- b). According to FCC Part 2 Section 2.1055(d)(2), for battery powered equipment, the frequency stability shall be measured with reducing primary supply voltage to the battery operating end point, which is specified by the manufacturer.
- c). According to FCC Part 90 Section 90.213, the frequency tolerance must be maintained within 0.00025% for 12.5KHz channel separation and 0.0005% for 25KHz channel separation.

6.2 MEASUREMENT PROCEDURE

6.2.1 Frequency stability versus environmental temperature

1. Setup the configuration per figure 1 for frequencies measurement inside an environment chamber, Install new battery in the EUT.
2. Turn on EUT and set SA center frequency to the EUT radiated frequency. Set SA Resolution Bandwidth to 1KHz and Video Resolution Bandwidth to 1KHz and Frequency Span to 50KHz. Record this frequency as reference frequency.
3. Set the temperature of chamber to 50°C . Allow sufficient time (approximately 30 min) for the temperature of the chamber to stabilize. While maintaining a constant temperature inside the chamber, turn the EUT on and measure the EUT operating frequency.
4. Repeat step 2 with a 10°C decreased per stage until the lowest temperature -30°C is measured, record all measured frequencies on each temperature step.

6.2.2 Frequency stability versus input voltage

1. Setup the configuration per figure 1 for frequencies measured at temperature if it is within 15°C to 25°C . Otherwise, an environment chamber set for a temperature of 20°C shall be used. The EUT shall be powered by DC 7.4V
2. Set SA center frequency to the EUT radiated frequency. Set SA Resolution Bandwidth to 1 KHz and Video Resolution Bandwidth to 1KHz. Record this frequency as reference frequency.
3. Supply the EUT primary voltage at the operating end point which is specified by manufacturer and record the frequency.

6.3 TEST SETUP BLOCK DIAGRAM

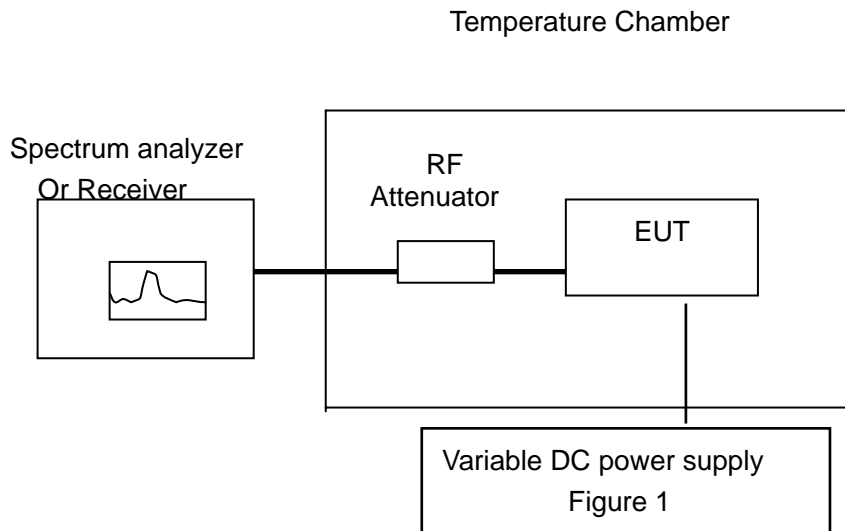

6.4 TEST EQUIPMENT USED:

NAME OF EQUIPMENT	MANUFACTURER	MODEL	SERIAL NUMBER	Cal. Date	Cal. Due
Receiver	R&S	ESCI	N/A	07/18/2013	07/17/2014
Climate Chamber	EXPERY	TN-400	N/A	07/18/2013	07/17/2014

6.5 TEST RESULT

(1) Frequency stability versus input voltage (Supply nominal voltage is 7.4V)

Bottom Channel @ 12.5 KHz Channel Separation

Reference Frequency:	400.225 MHz	Limit:	2.5ppm
Environment Temperature	Power Supply	Frequency Deviation	
(°C)	(V)	(MHz)	ppm
50	DC 7.4 V	400.225059	0.147
40	DC 7.4 V	400.225041	0.102
30	DC 7.4 V	400.225031	0.077
20	DC 7.4 V	400.225029	0.072
10	DC 7.4 V	400.225011	0.027
0	DC 7.4 V	400.225007	0.017
-10	DC 7.4 V	400.225004	0.010
-20	DC 7.4 V	400.225002	0.005
-30	DC 7.4 V	400.225013	0.032

Middle Channel @ 12.5 KHz Channel Separation

Reference Frequency:	435.225 MHz	Limit:	2.5ppm
Environment Temperature	Power Supply	Frequency Deviation	
(°C)	(V)	(MHz)	ppm
50	DC 7.4 V	435.225073	0.168
40	DC 7.4 V	435.225062	0.142
30	DC 7.4 V	435.225053	0.122
20	DC 7.4 V	435.225033	0.076
10	DC 7.4 V	435.225031	0.071
0	DC 7.4 V	435.225027	0.062
-10	DC 7.4 V	435.225021	0.048
-20	DC 7.4 V	435.225018	0.041
-30	DC 7.4 V	435.225011	0.025

Top Channel @ 12.5KHz Channel Separation

Reference Frequency:	469.975 MHz	Limit:	2.5ppm
Environment Temperature	Power Supply	Frequency Deviation	
(°C)	(V)	(MHz)	ppm
50	DC 7.4 V	469.975074	0.157
40	DC 7.4 V	469.975069	0.147
30	DC 7.4 V	469.975058	0.123
20	DC 7.4 V	469.975043	0.091
10	DC 7.4 V	469.975048	0.102
0	DC 7.4 V	469.975042	0.089
-10	DC 7.4 V	469.975038	0.081
-20	DC 7.4 V	469.975029	0.062
-30	DC 7.4 V	469.975015	0.032

(2) Frequency stability versus input voltage (Battery Limiting voltage is 6.29V)

Bottom Channel @ 12.5 KHz Channel Separation

Reference Frequency:	400.225 MHz	Limit:	2.5ppm
Environment Temperature	Power Supply	Frequency Deviation	
(°C)	(V)	(MHz)	ppm
50	DC 6.29 V	400.225081	0.202
40	DC 6.29 V	400.225076	0.190
30	DC 6.29 V	400.225059	0.147
20	DC 6.29 V	400.225052	0.130
10	DC 6.29 V	400.225043	0.107
0	DC 6.29 V	400.225035	0.087
-10	DC 6.29 V	400.225032	0.080
-20	DC 6.29 V	400.225021	0.052
-30	DC 6.29 V	400.225011	0.027

Middle Channel @ 12.5 KHz Channel Separation

Reference Frequency:	435.225 MHz	Limit:	2.5ppm
Environment Temperature	Power Supply	Frequency Deviation	
(°C)	(V)	(MHz)	ppm
50	DC 6.29 V	435.225098	0.225
40	DC 6.29 V	435.225076	0.175
30	DC 6.29 V	435.225069	0.159
20	DC 6.29 V	435.225058	0.133
10	DC 6.29 V	435.225047	0.108
0	DC 6.29 V	435.225045	0.103
-10	DC 6.29 V	435.225034	0.078
-20	DC 6.29 V	435.225021	0.048
-30	DC 6.29 V	435.225021	0.048

Top Channel @ 12.5KHz Channel Separation

Reference Frequency:	469.975 MHz	Limit:	2.5ppm
Environment Temperature	Power Supply	Frequency Deviation	
(°C)	(V)	(MHz)	ppm
50	DC 6.29 V	469.975091	0.194
40	DC 6.29 V	469.975089	0.189
30	DC 6.29 V	469.975076	0.162
20	DC 6.29 V	469.975043	0.091
10	DC 6.29 V	469.975032	0.068
0	DC 6.29 V	469.975023	0.049
-10	DC 6.29 V	469.975027	0.057
-20	DC 6.29 V	469.975026	0.055
-30	DC 6.29 V	469.975025	0.053

7. EMISSION BANDWIDTH

7.1 PROVISIONS APPLICABLE

According to FCC Part 90 Section 90.209: The authorized bandwidth shall be 11.25 KHz for 12.5 KHz

7.2 MEASUREMENT PROCEDURE

- 1). The EUT was placed on a turntable which is 0.8m above ground plane.
- 2). The EUT was modulated by 2.5 KHz Sine wave audio signal, The level of the audio signal employed is 16 dB greater than that necessary to produce 50% of rated system deviation. Rated system deviation is 2.5 kHz (12.5 kHz channel spacing) and
- 3). Set SPA Center Frequency = fundamental frequency, RBW=VBW= 300 Hz, Span =50 KHz.
- 4). Set SPA Max hold. Mark peak, -26 dB.

7.3 TEST SETUP BLOCK DIAGRAM

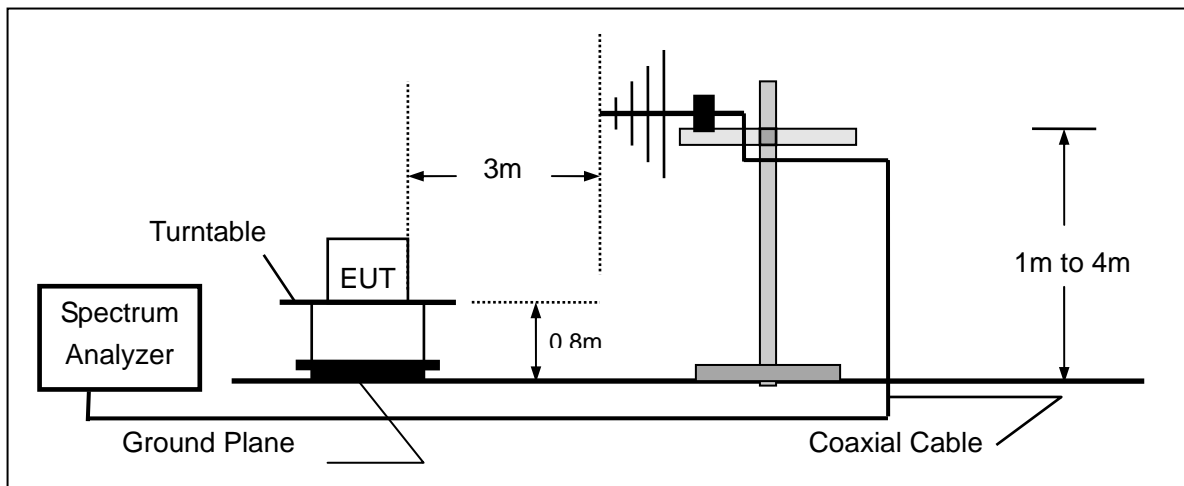

7.4 MEASUREMENT EQUIPMENT USED:

NAME OF EQUIPMENT	MANUFACTURER	MODEL	SERIAL NUMBER	Cal. Date	Cal. Due
SPECTRUM ANALYZER	AGILENT	E4440A	US44300399	07/18/2013	07/17/2014
MODULATION ANALYZER	HP	8920B	3104A03367	07/18/2013	07/17/2014
BROADBAND ANT.	A.H.	SAS-521-4	A0304224	06/08/2013	06/07/2014

7.5 MEASUREMENT RESULT:

26 dB Bandwidth Measurement Result			
Operating Frequency	12.5 KHz Channel Separation		
	Test Data	Limits	Result
400.225MHz	10.16 KHz	11.25 KHz	Pass
436.225MHz	10.29KHz	11.25 KHz	Pass
469.975MHz	10.07KHz	11.25 KHz	Pass

Occupied bandwidth of Middle Channel (Maximum) @ 12.5KHz Channel Separation

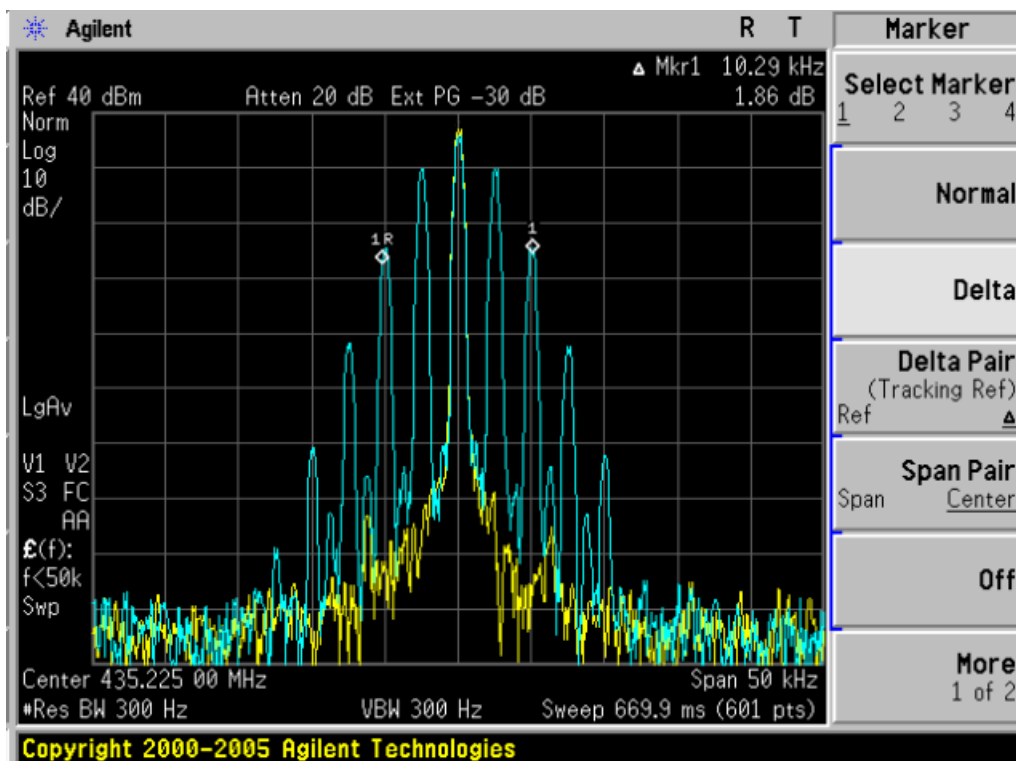

8. UNWANTED RADIATION

8.1 PROVISIONS APPLICABLE

8.1.1 According to Section 90.210, the power of each unwanted emission shall be less than Transmitted Power as specified below for transmitters designed to operate with 12.5 KHz channel bandwidth:

- (1). On any frequency removed from the center of the authorized bandwidth f_0 to 5.625 KHz removed from f_0 : Zero dB
- (2). On any frequency removed from the center of the authorized bandwidth by a displacement frequency (f_d in KHz) f_0 of more than 5.625 KHz but no more than 12.5 KHz: At least $7.27(f_d - 2.88 \text{ KHz})$ dB
- (3). On any frequency removed from the center of the authorized bandwidth by a displacement Frequency (f_d in KHz) f_0 of more than 12.5 KHz: At least $50 + 10 \log(P)$ dB or 70 dB, whichever is lesser attenuation.

8.2 MEASUREMENT PROCEDURE

- (1) On a test site, the EUT shall be placed on a turntable, and in the position closest to the normal use as declared by the user.
- (2) The test antenna shall be oriented initially for vertical polarization located 3m from the EUT to correspond to the transmitter.
- (3) The output of the antenna shall be connected to the measuring receiver and either a peak or quasi-peak detector was used for the measurement as indicated on the report. The detector selection is based on how close the emission level was approaching the limit.
- (4) The transmitter shall be switched on; if possible, without the modulation and the measurement receiver shall be tuned to the frequency of the transmitter under test.
- (5) The test antenna shall be raised and lowered through the specified range of height until the measuring receiver detects a maximum signal level.
- (6) The transmitter shall then be rotated through 360° in the horizontal plane, until the maximum signal level is detected by the measuring receiver.
- (7) The test antenna shall be raised and lowered again through the specified range of height until the measuring receiver detects a maximum signal level.

- (8) The maximum signal level detected by the measuring receiver shall be noted.
- (9) The measurement shall be repeated with the test antenna set to horizontal polarization.
- (10) Replace the antenna with a proper Antenna (substitution antenna).
- (11) The substitution antenna shall be oriented for vertical polarization and, if necessary, the length of the substitution antenna shall be adjusted to correspond to the frequency of transmitting.
- (12) The substitution antenna shall be connected to a calibrated signal generator.
- (13) If necessary, the input attenuator setting of the measuring receiver shall be adjusted in order to increase the sensitivity of the measuring receiver.
- (14) The test antenna shall be raised and lowered through the specified range of the height to ensure that the maximum signal is received.

(15) The input signal to substitution antenna shall be adjusted to the level that produces a level detected by the measuring receiver, that is equal to the level noted while the transmitter radiated power was measured, corrected for the change of input attenuation setting of the measuring receiver.

(16) The input level to the substitution antenna shall be recorded as power level in dBm, corrected for any change of input attenuator setting of the measuring receiver.

(17) The measurement shall be repeated with the test antenna and the substitution antenna oriented for horizontal polarization.

8.3 TEST SETUP BLOCK DIAGRAM

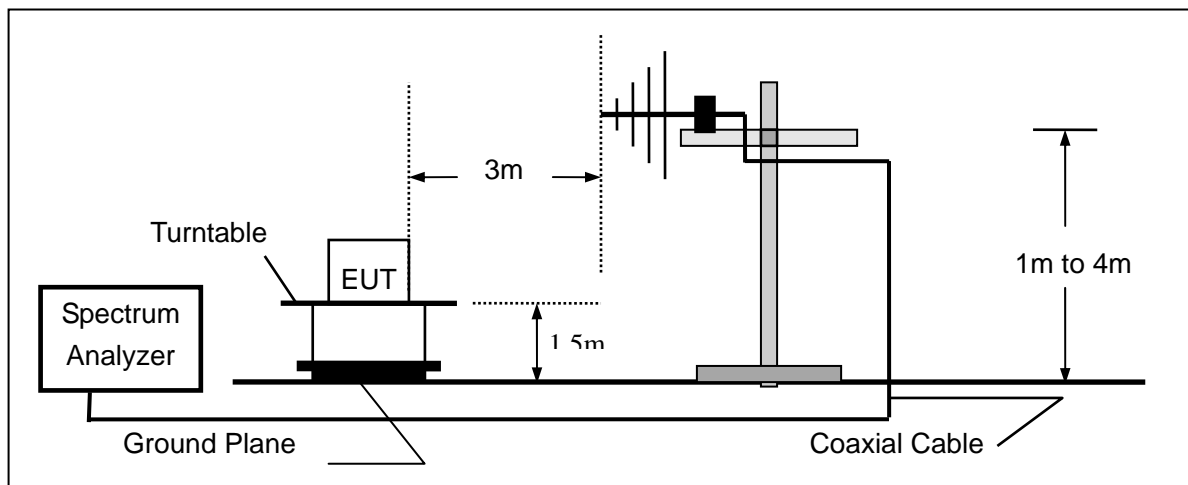

SUBSTITUTION METHOD: (Radiated Emissions)

Radiated Below 1GHz

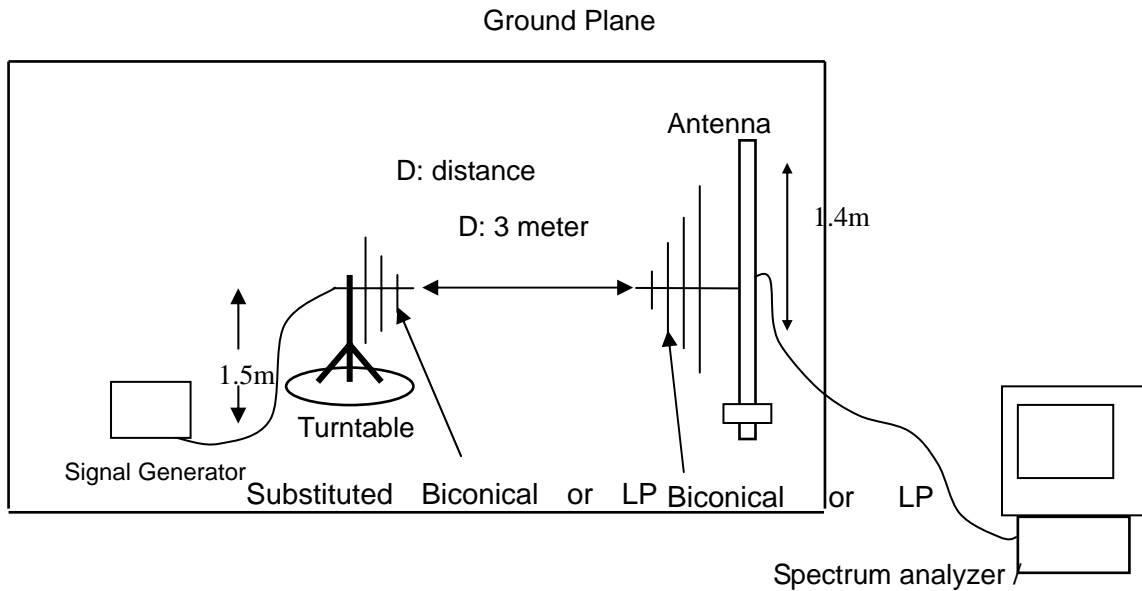

Radiated Above 1 GHz

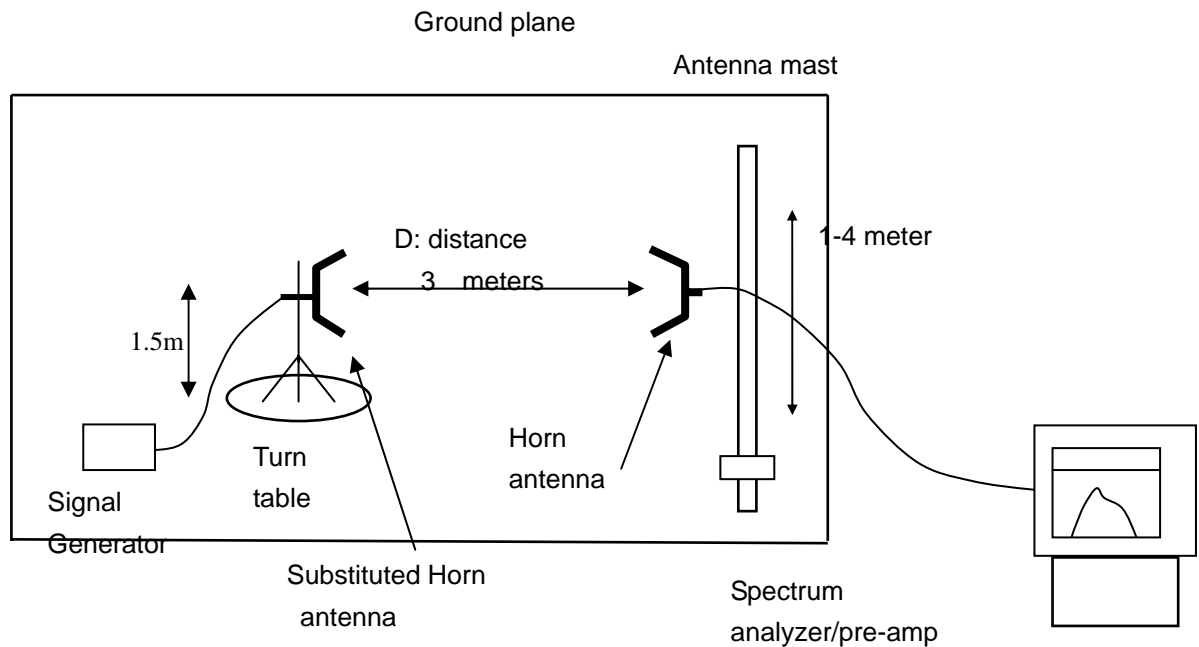

8.4 MEASUREMENT EQUIPMENT USED:

NAME OF EQUIPMENT	MANUFACTURER	MODEL	SERIAL NUMBER	Cal. Date	Cal. Due
SPECTRUM ANALYZER	AGILENT	E4440A	US44300399	07/18/2013	07/17/2014
HORN ANT.	EM	EM-AH-10180	100150	04/21/2014	04/20/2015
BROADBAND ANT.	A.H.	SAS-521-4	A0304224	06/08/2013	06/07/2014
AMPLIFIER	EM	EM30180	0607030	07/18/2013	07/17/2014
POSITIONING CONTROLLER	MF	MF-7802	MF780208147	--	--
Substitution Antenna	EMCO	3142C	---	06/07/2013	06/06/2014
Substitution Antenna	EM	EM-AH-10180	67	07/20/2013	07/19/2014
Horn Antenna	A.H. Systems Inc.	SAS-574	--	07/17/2013	07/16/2014
SIGNAL GENERATOR	Agilent	E4421B	122501288	07/17/2013	07/16/2014

8.5 MEASUREMENT RESULTS:

Measurement Result for 12.5 KHz Channel Separation-5W

On any frequency removed from the center of the authorized bandwidth by a displacement Frequency (f_d in KHz) of more than 12.5 KHz: At least $50+10 \log(P)$ dB or 70 dB, which ever is lesser attenuation.

Limit: At least $50+10 \log(P) = 50+10\log(5)=57$

Measurement Result For 25 KHz Channel Separation-5W

On any frequency removed from the assigned frequency by more than 250 percent of the authorized bandwidth: At least $43+10\log(P)$ dB.

Limit: At least $43+10 \log(P) = 43+10\log(5)=50$

Measurement Result for 12.5 KHz Channel Separation @ 400.225MHz

Emission Frequency (MHz)	Ant. Polarity(H/V)	Measurement Result Below carrier(dBc)	Limit	Result(P/F)
400.225	v	0		pass
800.450	v	77.67(-40.67dBm)	50	pass
1200.68	v	74.22(-37.22dBm)	50	pass
1600.900	v	76.01(-39.01dBm)	50	pass
2001.125	v	84.24	50	pass
2401.350	v	82.78	50	pass
2801.575	v	92.54	50	pass
3201.800	v	91.76	50	pass
3602.025	v	92.43	50	pass
4002.250	v	92.24	50	pass

Measurement Result for 12.5 KHz Channel Separation @ 435.225MHz

Emission Frequency (MHz)	Ant. Polarity(H/V)	Measurement Result Below carrier(dBc)	Limit	Result(P/F)
435.225	v	0		pass
870.450	v	75.44(-38.44dBm)	50	pass
1305.675	v	79.39	50	pass
1740.900	v	81.46	50	pass
2176.125	v	85.65	50	pass
2611.350	v	90.31	50	pass
3046.575	v	93.11	50	pass
3481.800	v	94.12	50	pass
3917.025	v	94.21	50	pass
4352.250	v	94.26	50	pass

Measurement Result for 12.5 KHz Channel Separation @ 469.95MHz

Emission Frequency (MHz)	Ant. Polarity(H/V)	Measurement Result Below carrier(dBc)	Limit	Result(P/F)
469.950	v	0		pass
939.900	v	76.43(-39.43dBm)	50	pass
1409.850	v	83.34	50	pass
1879.800	v	85.64	50	pass
2349.750	v	87.27	50	pass
2819.700	v	91.65	50	pass
3289.650	v	92.15	50	pass
3759.600	v	94.21	50	pass
4229.550	v	95.21	50	pass
4699.500	v	97.22	50	pass

Notes: The emissions were scanned from 30 MHz to 10th harmonics; The worst case for Transmitter spurious is 37dBm-74.22dBc=-37.22dBm

8.6 EMISSION MASK PLOT

The detailed procedure employed for Emission Mask measurements are specified as following:

- The transmitter shall be modulated by a 2.5 kHz audio signal,
- The level of the audio signal employed is 16 dB greater than that necessary to produce 50% of rated system deviation. Rated system deviation is 2.5 kHz (12.5 kHz channel spacing)

The Worst Emission Mask for 12.5 KHz channel Separation (5W)

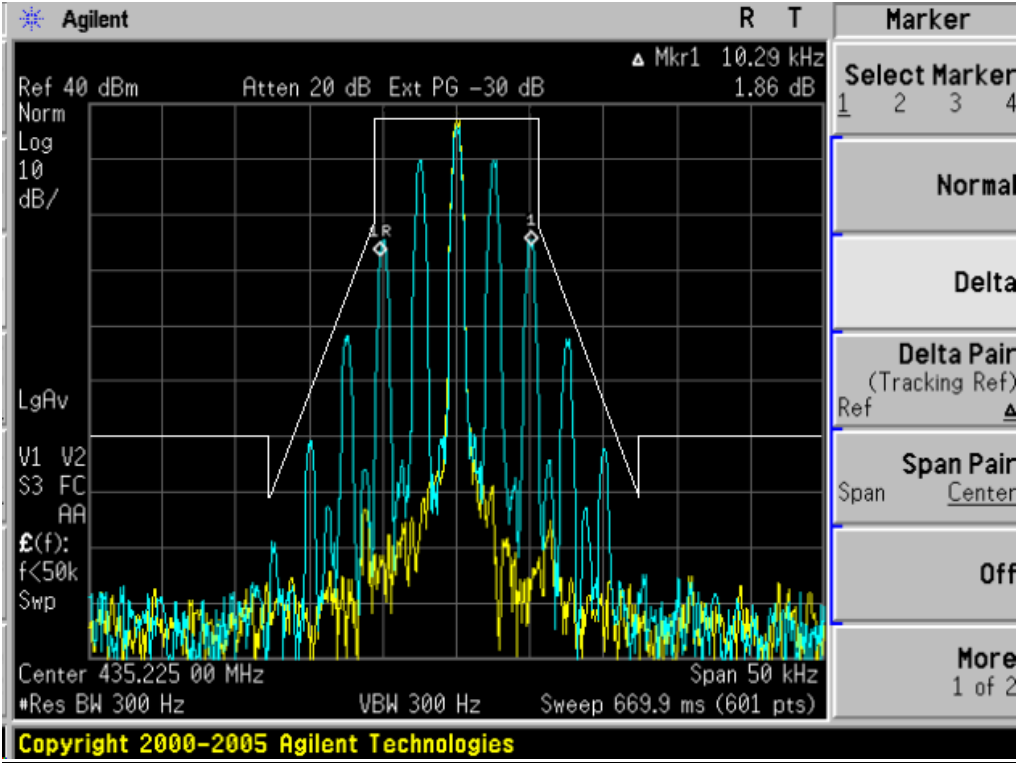

9. MODULATION CHARACTERISTICS

9.1 PROVISIONS APPLICABLE

According to CFR 47 section 2.1047(a), for Voice Modulation Communication Equipment, the frequency response of the audio modulation circuit over a range of 100 to 5000Hz shall be measured.

9.2 MEASUREMENT METHOD

9.2.1 Modulation Limit

- (1). Configure the EUT as shown in figure 1, adjust the audio input for 60% of rated system deviation at 1KHz using this level as a reference (0dB) and vary the input level from -20 to +20dB. Record the frequency deviation obtained as a function of the input level.
- (2). Repeat step 1 with input frequency changing to 300, 1000, 1500 and 3000Hz in sequence.

9.2.2 Audio Frequency Response

- (1). Configure the EUT as shown in figure 1.
- (2). Adjust the audio input for 20% of rated system deviation at 1 KHz using this level as a reference (0 dB).
- (3). Vary the Audio frequency from 100 Hz to 10 KHz and record the frequency deviation.
- (4). Audio Frequency Response = $20\log_{10}(\text{Deviation of test frequency}/\text{Deviation of 1 KHz reference})$.

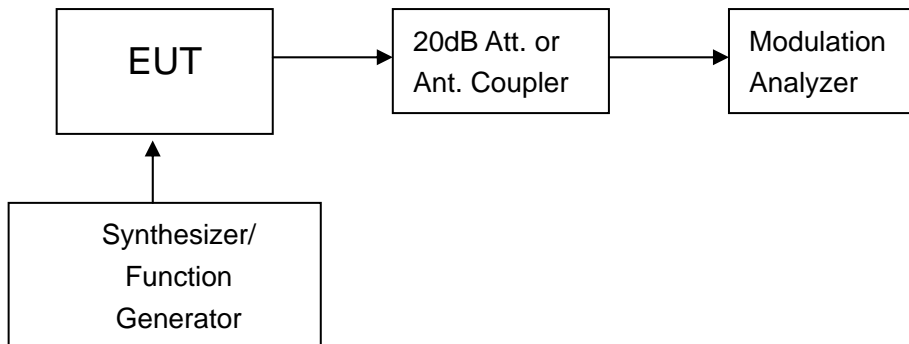

Figure 1: Modulation characteristic measurement configuration

9.3 MEASUREMENT INSTRUMENTS

NAME OF EQUIPMENT	MANUFACTURER	MODEL	SERIAL NUMBER	Cal. Date	Cal. Due
Modulation Analyzer	HP	8920B	3104A03367	07/18/2013	07/17/2014

NOTE: 8920B can generate audio modulation frequency.

9.4 MEASUREMENT RESULT

(a). Modulation Limit:

Middle Channel @ 12.5 KHz Channel Separations

Modulation Level (dB)	Peak Freq. Deviation At 300 Hz	Peak Freq. Deviation At 1000 Hz	Peak Freq. Deviation At 1500 Hz	Peak Freq. Deviation At 3000 Hz
-20	0.28	0.49	0.58	0.69
-15	0.41	0.67	0.75	0.95
-10	0.47	1.37	1.59	1.81
-5	0.69	1.85	1.93	2.17
0	0.78	2.37	2.51	2.63
+5	0.88	2.47	2.55	2.61
+10	0.92	2.52	2.69	2.78
+15	0.89	2.43	2.53	2.69
+20	0.78	2.26	2.32	2.41

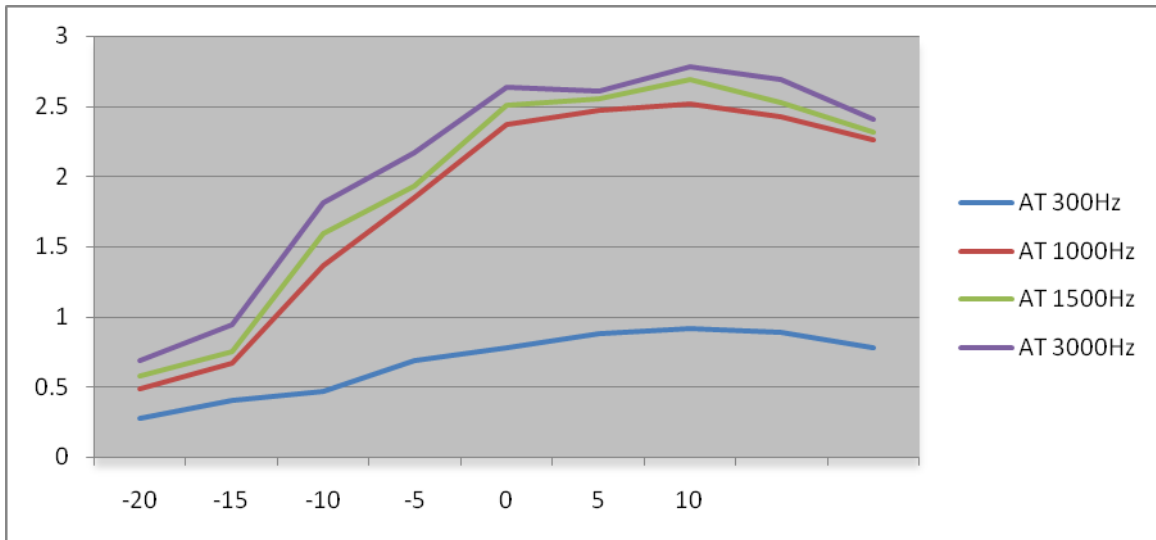

(b). Audio Frequency Response:

12.5 KHz Channel Separations

Frequency (Hz)	Deviation (KHz)	Audio Frequency Response(dB)
100	--	--
200	--	--
300	0.12	-16.48
400	0.23	-10.83
500	0.26	-9.76
600	0.32	-7.96
700	0.37	-6.70
800	0.4	-6.02
900	0.45	-5.00
1000	0.5	-4.08
1200	0.6	-2.50
1400	0.68	-1.41
1600	0.76	-0.45
1800	0.86	0.63
2000	0.92	1.21
2400	1.04	2.28
2500	1.04	2.28
2800	1.07	2.53
3000	1.09	2.69
3200	0.87	0.73
3600	0.47	-4.62
4000	0.25	-10.10
4500	0.19	-12.49
5000	0.12	-16.48
5500	0.07	-21.16
6000	0.06	-22.50
6500	0.03	-28.52
7000	0.02	-32.04
7500	0.01	-38.06
9000	--	--
10000	--	--
14000	--	--
18000	--	--
20000	--	--
30000	--	--

Frequency Response of Middle Channel

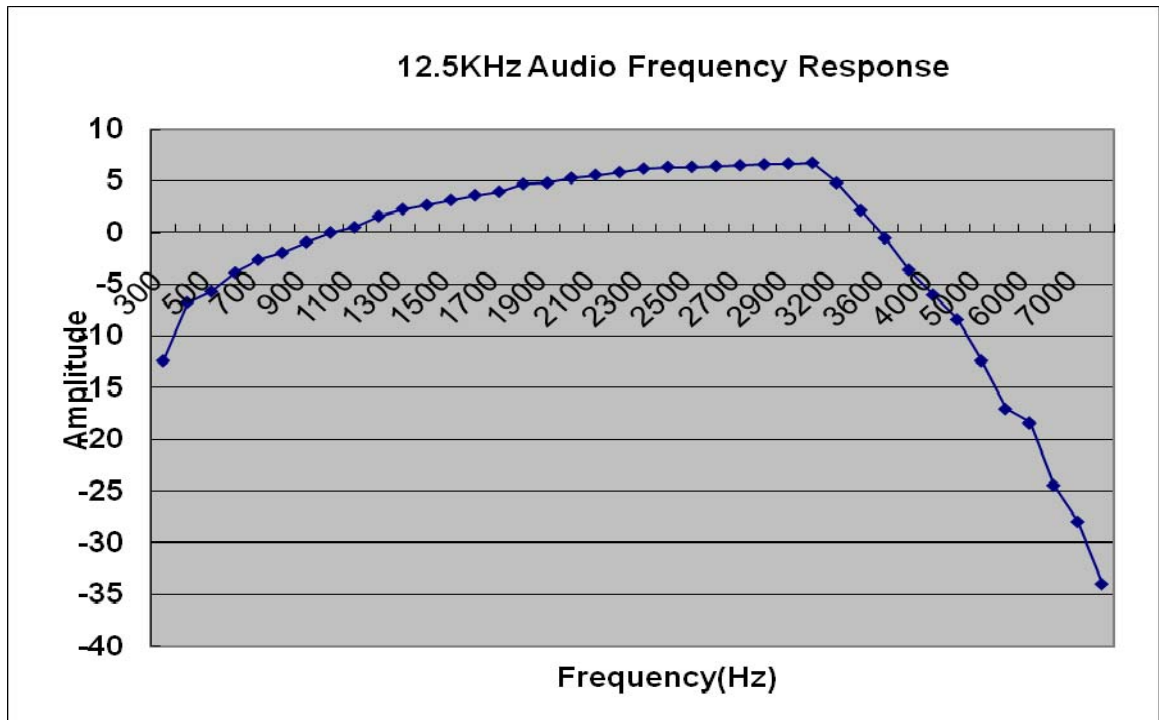

Note: All the modes had been tested, but only the worst data recorded in the report.

10. MAXIMUM TRANSMITTER POWER (CONDUCTED OUTPUT POWER)

10.1 PROVISIONS APPLICABLE

Per FCC §2.1046 and §90.205 AND RSS 119 Part 4.1: Maximum ERP is dependent upon the station’s antenna HAAT and required service area.

10.2 TEST PROCEDURE

The RF output of Two-way Radio was conducted to a spectrum analyzer through an appropriate attenuator.

10.3 TEST INSTRUMENTS

NAME OF EQUIPMENT	MANUFACTURER	MODEL	SERIAL NUMBER	Cal. Date	Cal. Due
SPECTRUM ANALYZER	AGILENT	E4440A	US44300399	07/18/2013	07/17/2014

10.4 TEST CONFIGURATION

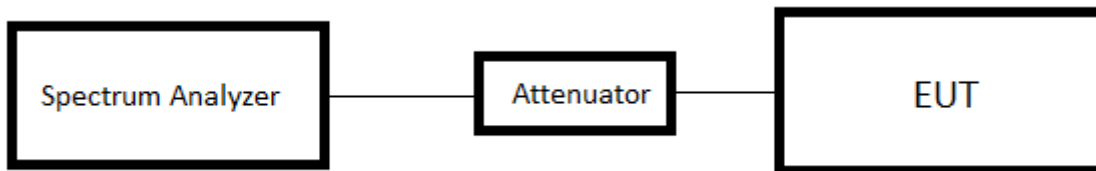

10.5 TEST RESULT

The maximum Conducted Power (CP) is
5 W for 12.5 KHz Channel Separation

Calculation Formula: CP = R + A + L

* Note:

- CP: The final Conducted Power
- R : The reading value from spectrum analyzer
- A : The attenuation value of the used attenuator
- L : The loss of all connection cables

Conducted Power Measurement Results		
Channel Separation	Channel	Measurement Result (dBm)
		For 37dBm(5W)
12.5 KHz	Bottom(400.225MHz)	37.14
	Middle(440.875MHz)	37.12
	Top (469.975MHz)	37.15

10.4 CONDUCT SPURIOUS PLOT

Conducted Spurious Emission(worst) @ 435.225MHz (30MHz-1GHz)

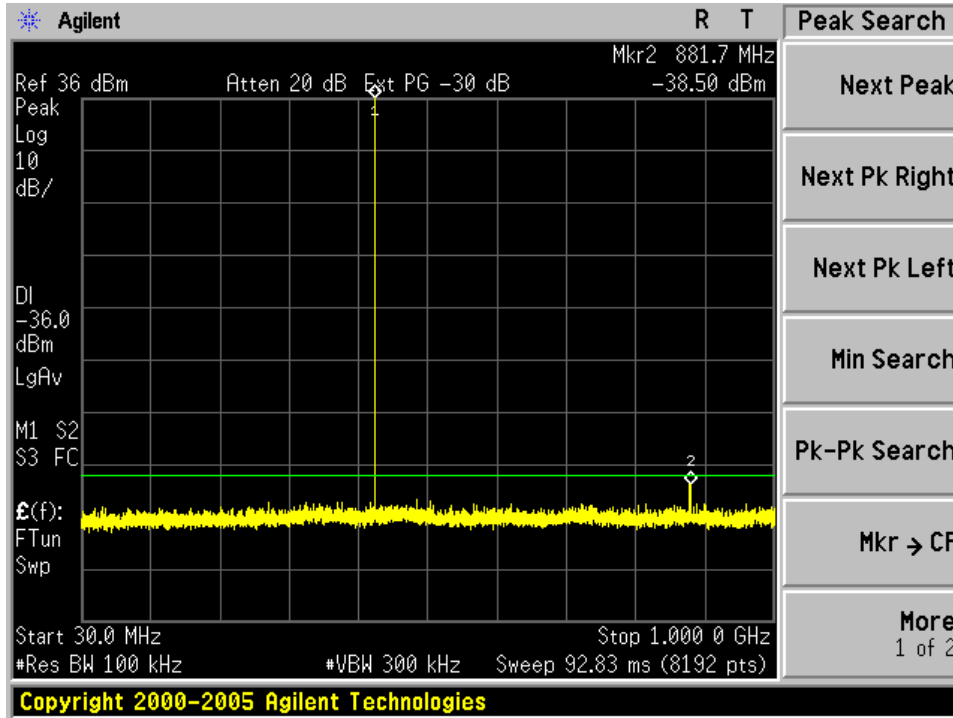

Conduct Spurious Emission(worst) @ 435.225 (1GHz-9GHz)

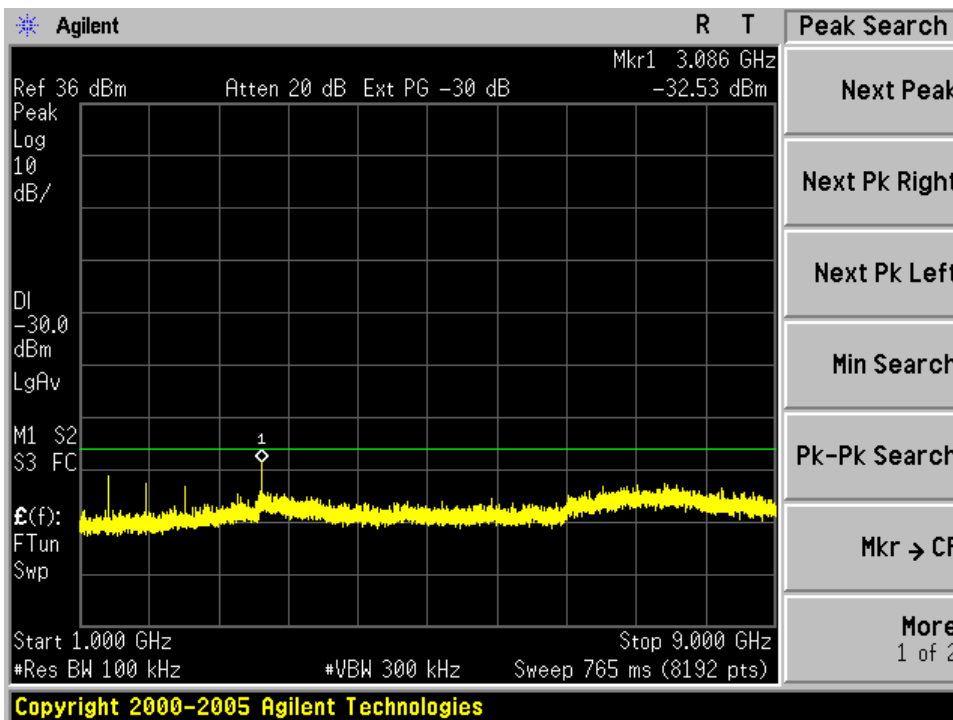

Conduct Spurious Emission(worst) @ 435.225 (9GHz-12.75GHz)

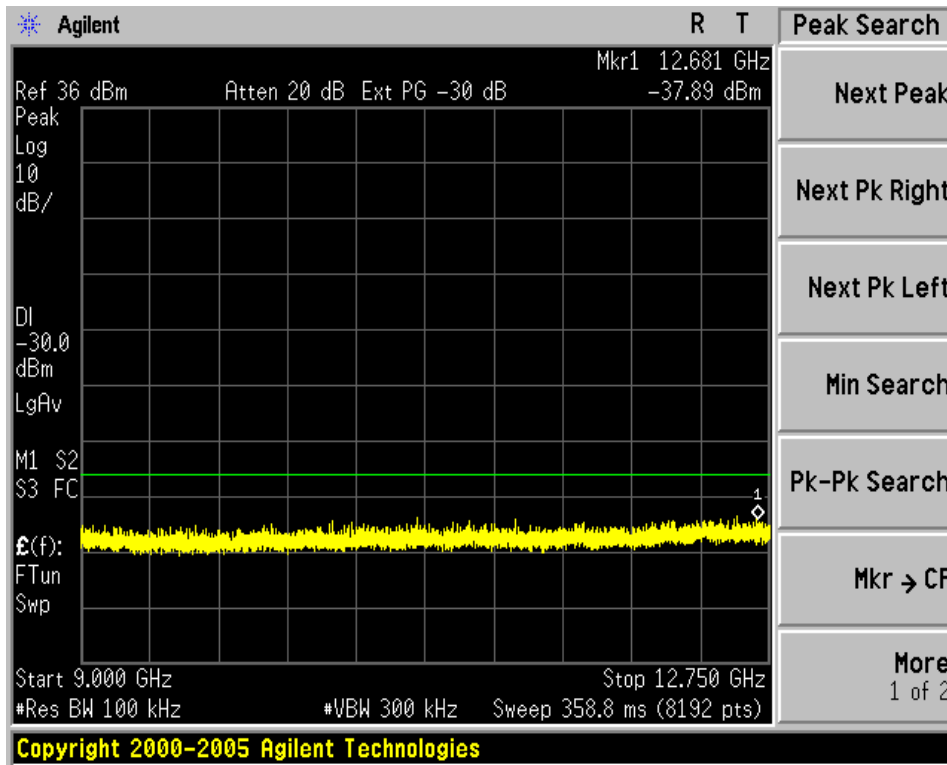

11. TRANSMITTER FREQUENCY BEHAVIOR

11.1 PROVISIONS APPLICABLE

Section 90.214

Time intervals ^{1, 2}	Maximum frequency difference ³	All equipment	
		150 to 174 MHz	421 to 512 MHz
Transient Frequency Behavior for Equipment Designed to Operate on 25 kHz Channels			
t ₁ ⁴	± 25.0 kHz	5.0 ms	10.0 ms
t ₂	± 12.5 kHz	20.0 ms	25.0 ms
t ₃ ⁴	± 25.0 kHz	5.0 ms	10.0 ms
Transient Frequency Behavior for Equipment Designed to Operate on 12.5 kHz Channels			
t ₁ ⁴	± 12.5 kHz	5.0 ms	10.0 ms
t ₂	± 6.25 kHz	20.0 ms	25.0 ms
t ₃ ⁴	± 12.5 kHz	5.0 ms	10.0 ms
Transient Frequency Behavior for Equipment Designed to Operate on 6.25 kHz Channels			
t ₁ ⁴	± 6.25 kHz	5.0 ms	10.0 ms
t ₂	± 3.125 kHz	20.0 ms	25.0 ms
t ₃ ⁴	± 6.25 kHz	5.0 ms	10.0 ms

¹ t_{on} is the instant when a 1 kHz test signal is completely suppressed, including any capture time due to phasing.

t₁ is the time period immediately following t_{on}.

t₂ is the time period immediately following t₁.

t₃ is the time period from the instant when the transmitter is turned off until t_{off}.

t_{off} is the instant when the 1 kHz test signal starts to rise.

² During the time from the end of t₂ to the beginning of t₃, the frequency difference must not exceed the limits specified in §90.213.

³ Difference between the actual transmitter frequency and the assigned transmitter frequency.

⁴ If the transmitter carrier output power rating is 6 watts or less, the frequency difference during this time period may exceed the maximum frequency difference for this time period.

11.2 TEST METHOD

TIA/EIA-603 2.2.19

11.3 TEST INSTRUMENTS

NAME OF EQUIPMENT	MANUFACTURER	MODEL	SERIAL NUMBER	Cal. Date	Cal. Due
Signal Generator	AGILENT	E4412B	LR114196	05/29/2013	05/28/2014
Storage Oscilloscope	Tektronix	TDS3052	B017447	07/18/2013	07/17/2014

11.4 DESCRIBE LIMIT LINE OF TRANSMITTER FREQUENCY BEHAVIOR

ton: The switch-on instant t_{on} of a transmitter is defined by the condition when the output power, measured at the antenna terminal, exceeds 0,1 % of the full output power (-30 dBc).

t1: period of time starting at t_{on} and finishing according to above 11.1

t2: period of time starting at the end of t_1 and finishing according to above 11.1

toff: switch-off instant defined by the condition when the output power falls below 0,1 % of the full output power (-30 dBc).

t3: period of time that finishing at t_{off} and starting according to above 11.1

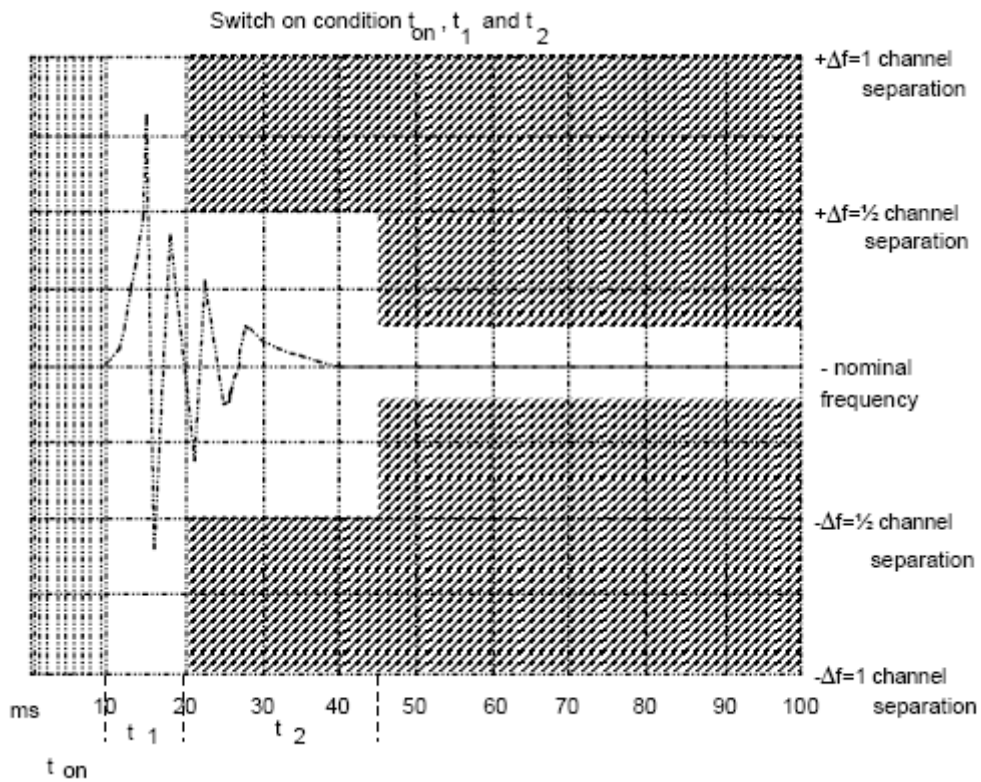

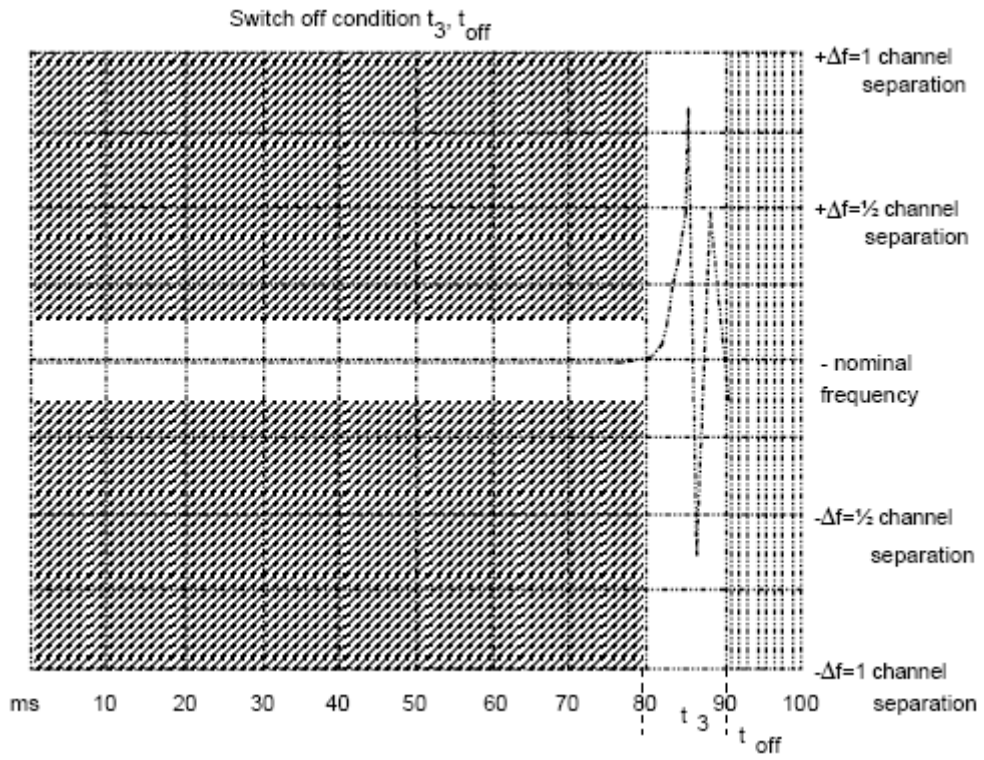

11.5 MEASURE RESULT

Transmitter Frequency Behaviour @ 12.5 KHz Channel Separation--Off to On

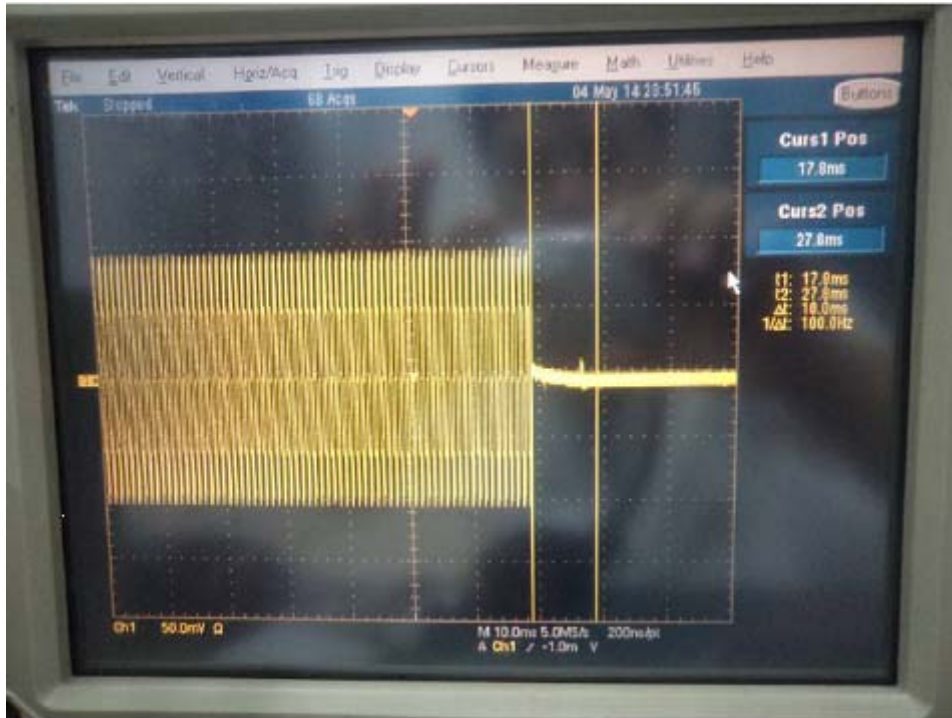

Transmitter Frequency Behaviour @ 12.5 KHz Channel Separation--On to Off

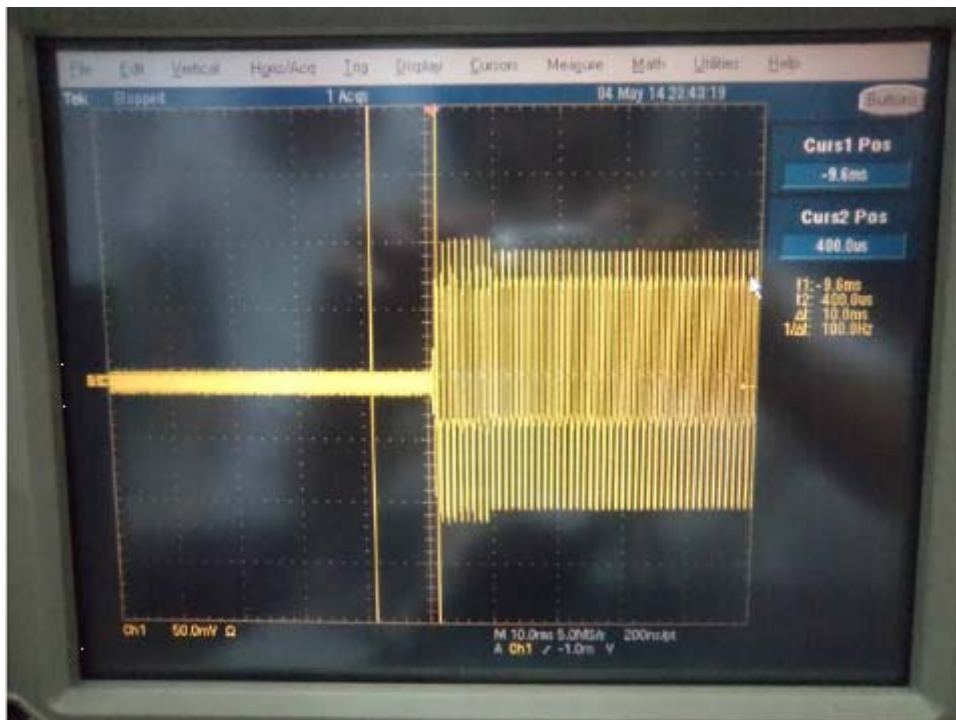

12. Radiated Emission on Receiving Mode

12.1 PROVISIONS APPLICABLE

FCC Part 15 Subpart B Section 15.109

12.2 TEST METHOD

ANSI C 63.4: 2003

12.3 TEST INSTRUMENTS

NAME OF EQUIPMENT	MANUFACTURER	MODEL	SERIAL NUMBER	Cal. Date	Cal. Due
SPECTRUM ANALYZER	AGILENT	E4440A	US44300399	07/18/2013	07/17/2014
HORN ANT.	EM	EM-AH-10180	100150	04/20/2014	04/19/2015
BROADBAND ANT.	A.H.	SAS-521-4	A0304224	06/08/2013	06/07/2014
AMPLIFIER	EM	EM30180	0607030	07/18/2013	07/17/2014
POSITIONING CONTROLLER	MF	MF-7802	MF780208147	--	--

12.4 MEASURE RESULT (MEASURED AT 3M USING FCC PART15 B LIMITS)
RADIATED EMISSION TEST RESULTS – HORIZONTAL

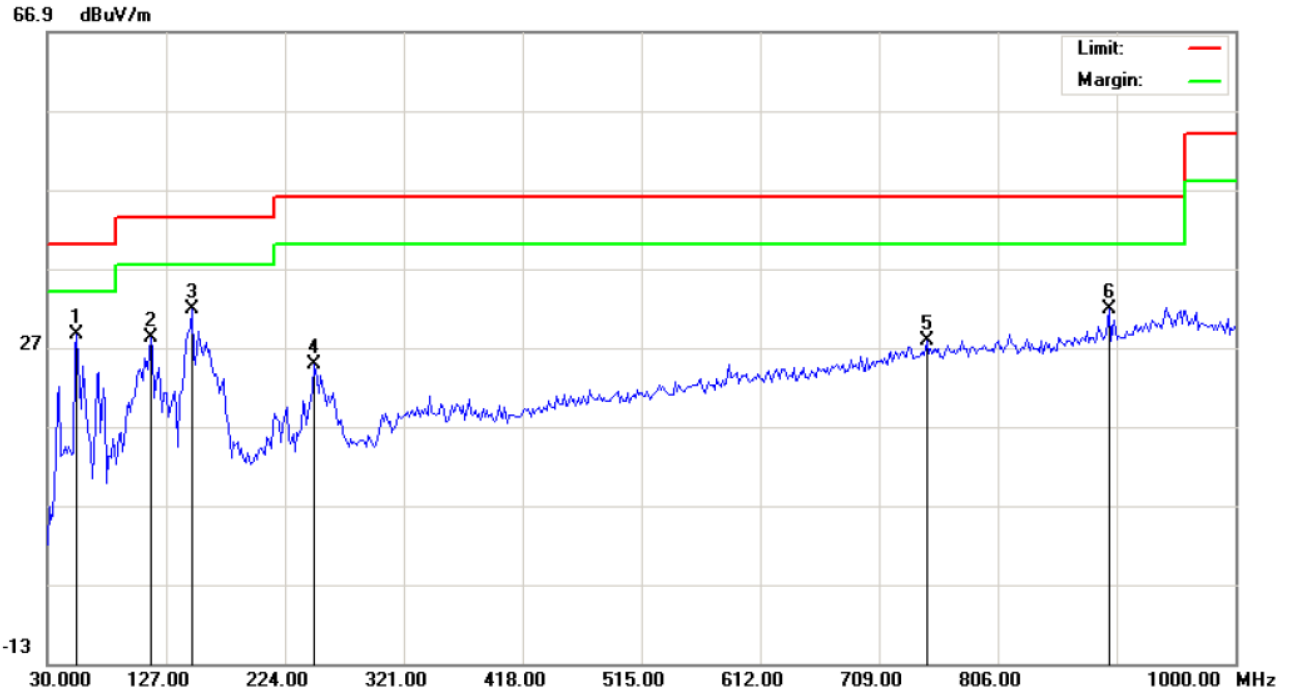

Site: site #1
Limit: FCC Class B 3M Radiation
EUT: UHF FM HANDHELD TRANSCEIVER
M/N: DJ-A41
Mode: Mode 1
Note:

Polarization: **Horizontal**
Power: AC 120V/60Hz
Distance:

Temperature: 26
Humidity: 60 %

No.	Mk	Freq.	Reading	Factor	Measurement	Limit	Over	Detector	Antenna Height	Table Degree	Comment
		MHz	dBuV	dB/m	dBuV/m	dBuV/m	dB		cm	degree	
1	*	54.2500	17.37	11.20	28.57	40.00	-11.43	peak			
2		114.0667	16.71	11.45	28.16	43.50	-15.34	peak			
3		148.0167	16.65	15.25	31.90	43.50	-11.60	peak			
4		248.2500	10.97	13.83	24.80	46.00	-21.20	peak			
5		747.8000	1.24	26.57	27.81	46.00	-18.19	peak			
6		896.5333	3.36	28.52	31.88	46.00	-14.12	peak			

RADIATED EMISSION TEST RESULTS – VERTICAL

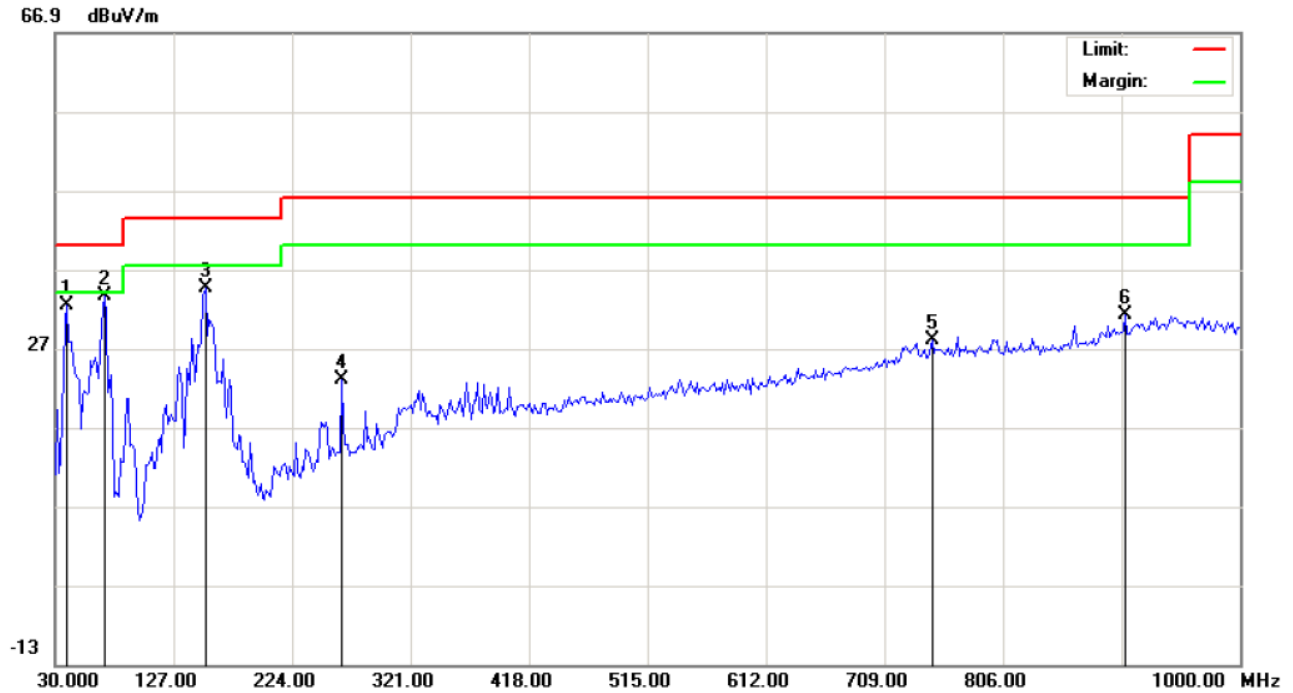

Site: site #1
 Limit: FCC Class B 3M Radiation
 EUT: UHF FM HANDHELD TRANSCEIVER
 M/N: DJ-A41
 Mode: Mode 1
 Note:

Polarization: **Vertical**
 Power: AC 120V/60Hz
 Distance:

Temperature: 26
 Humidity: 60 %

No.	Mk	Freq.	Reading	Factor	Measurement	Limit	Over	Detector	Antenna Height	Table Degree	Comment
		MHz	dBuV	dB/m	dBuV/m	dBuV/m	dB		cm	degree	
1		39.7000	23.87	8.51	32.38	40.00	-7.62	peak			
2	*	70.4167	29.35	4.16	33.51	40.00	-6.49	peak			
3		152.8667	19.36	15.28	34.64	43.50	-8.86	peak			
4		264.4166	8.70	14.34	23.04	46.00	-22.96	peak			
5		747.8000	1.51	26.57	28.08	46.00	-17.92	peak			
6		906.2333	2.42	28.78	31.20	46.00	-14.80	peak			

13. Audio Low Pass Filter Response

13.1 LIMITS

2.1047(a): Voice modulated communication equipment. A curve or equivalent data showing the frequency response of the audio modulating circuit over a range of 100 to 5000 Hz shall be submitted. For equipment required to have an audio low-pass filter, a curve showing the frequency response of the filter or of all circuitry installed between the modulation limiter and the modulated stage shall be submitted.

90.242(b)(8): Recommended audio filter attenuation characteristics are given below:

Audio band	Minimum Attenuation Rel. to 1 KHz Attenuation
3 – 20 KHz	$60 \log_{10}(f/3)$ dB where f is in KHz
20 – 30 KHz	50dB

13.2. METHOD OF MEASUREMENTS

The rated audio input signal was applied to the input of the audio low-pass filter (or of all modulation stages) using an audio oscillator, this input signal level and its corresponding output signal were then measured and recorded using the FFT Digital Spectrum Analyzer. Tests were repeated at different audio signal frequencies from 0 to 50 KHz.

13.3 TEST DATA

12.5 KHz Channel Spacing, F3E, Frequency of All Modulation States

Frequency (KHz)	Audio In (dBV)	Audio out (dBV)	Attenuation (Out_In) dB	Attenuation Rel. to 3 KHz (dB)	Recommended Attenuation (dB)
0.1	-75.79	-30.25	45.6	-36.7	
0.2	-75.79	-18.83	57.1	-25.5	
0.4	-75.79	-5.27	70.4	-12.0	
0.6	-75.79	0.24	76.1	-6.4	
0.8	-75.79	4.08	79.7	-2.6	
1.0	-75.79	6.68	82.6	0.0	
1.5	-75.79	8.75	84.3	2.1	
2.0	-75.79	8.57	84.4	1.9	
2.5	-75.79	7.13	82.9	0.5	
3.0	-75.79	5.33	81.2	-1.3	0
3.5	-75.79	2.02	77.8	-4.2	-4
4.0	-75.79	-2.62	73.2	-9.5	-7
4.5	-75.79	-8.41	67.5	-15.2	-11
5.0	-75.79	-14.05	61.7	-20.5	-13
6.0	-75.79	-22.68	53.2	-29.4	-18
7.0	-75.79	-30.62	45.4	-37.5	-22
8.0	-75.79	-38.95	36.7	-45.5	-26
9.0	-75.79	-60.00	15.8	-66.7	-29
10.0	-75.79	-60.00	15.8	-66.7	-31
12.0	-75.79	-60.00	15.8	-66.7	-36
14.0	-75.79	-60.00	15.8	-66.7	-40
16.0	-75.79	-60.00	15.8	-66.7	-44
18.0	-75.79	-60.00	15.8	-66.7	-47
20.0	-75.79	-60.00	15.8	-66.7	-50
25.0	-75.79	-60.00	15.8	-66.7	-50
30.0	-75.79	-60.00	15.8	-66.7	-50
35.0	-75.79	-60.00	15.8	-66.7	-50
40.0	-75.79	-60.00	15.8	-66.7	-50
45.0	-75.79	-60.00	15.8	-66.7	-50
50.0	-75.79	-60.00	15.8	-66.7	-50

Note: Due to the difficulty of measuring the Frequency Response of the internal low-pass filter, the Frequency Response of All Modulation States is performed to show the roll-off at 3 KHz in comparison with the recommended audio filter attenuation.

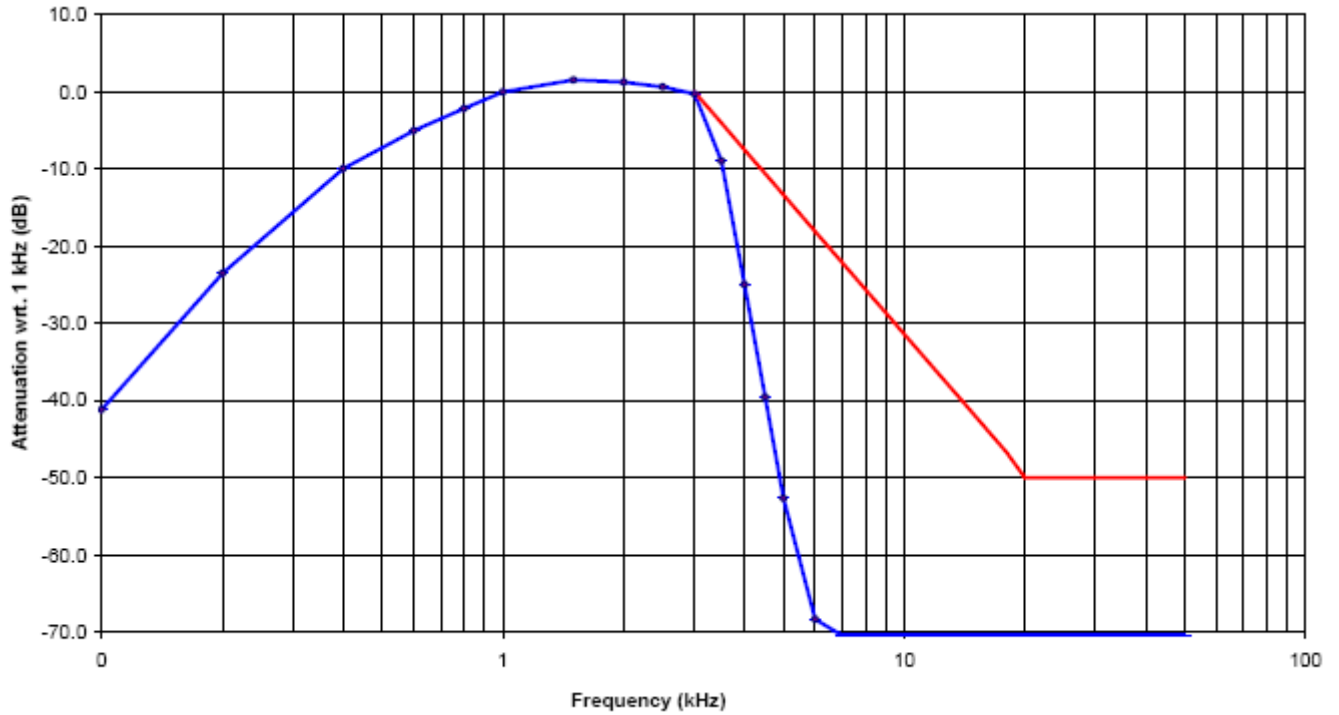

APPENDIX I

PHOTOGRAPHS OF SETUP

CONDUCTED EMISSION TEST SETUP



RADIATED TEST SETUP

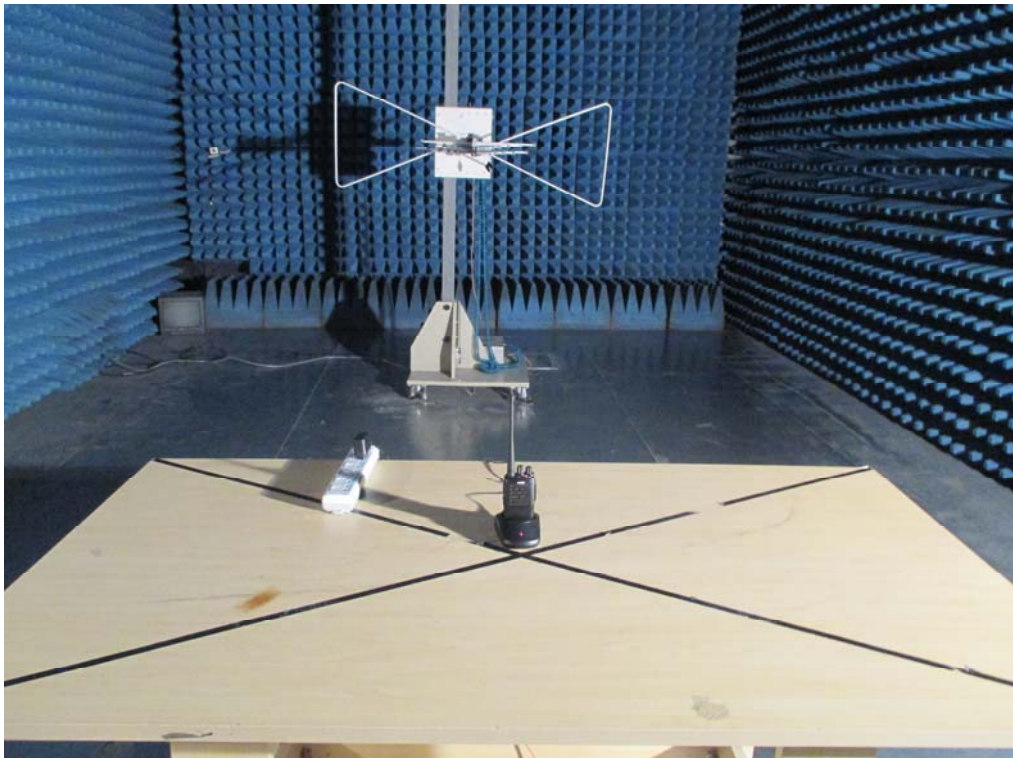

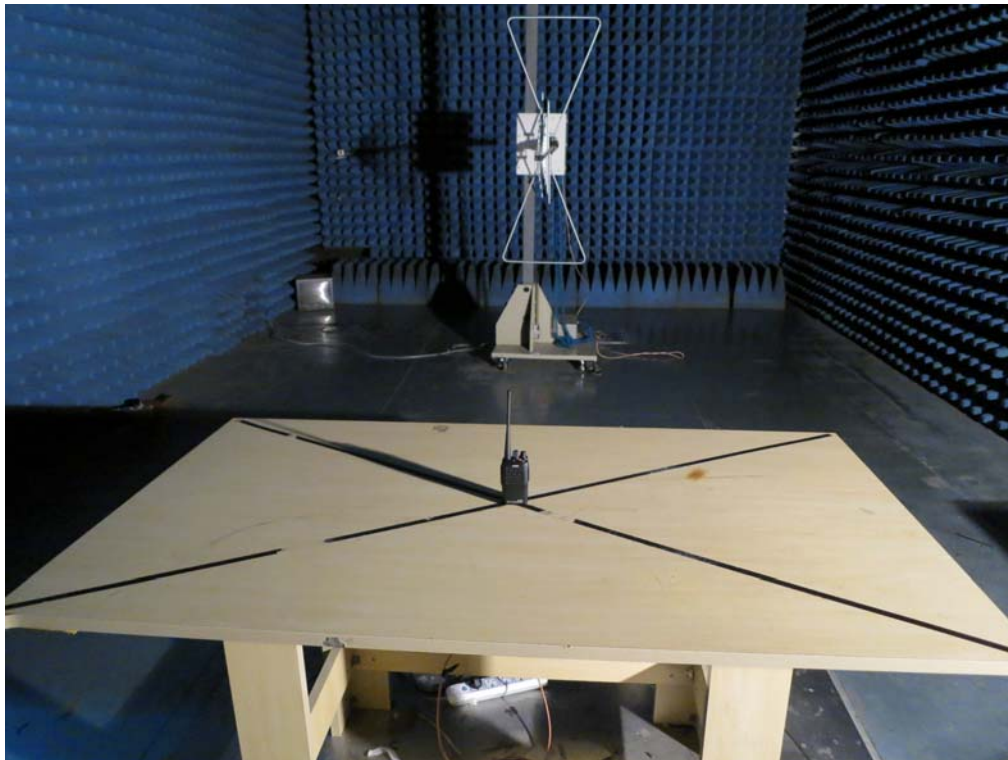

APPENDIX II

EXTERNAL VIEW OF EUT

TOTAL VIEW OF EUT



TOP VIEW OF EUT



BOTTOM VIEW OF EUT



FRONT VIEW OF EUT



BACK VIEW OF EUT



LEFT VIEW OF EUT



RIGHT VIEW OF EUT



OPEN VIEW OF EUT-1



OPEN VIEW OF EUT-2



OPEN VIEW OF EUT-3

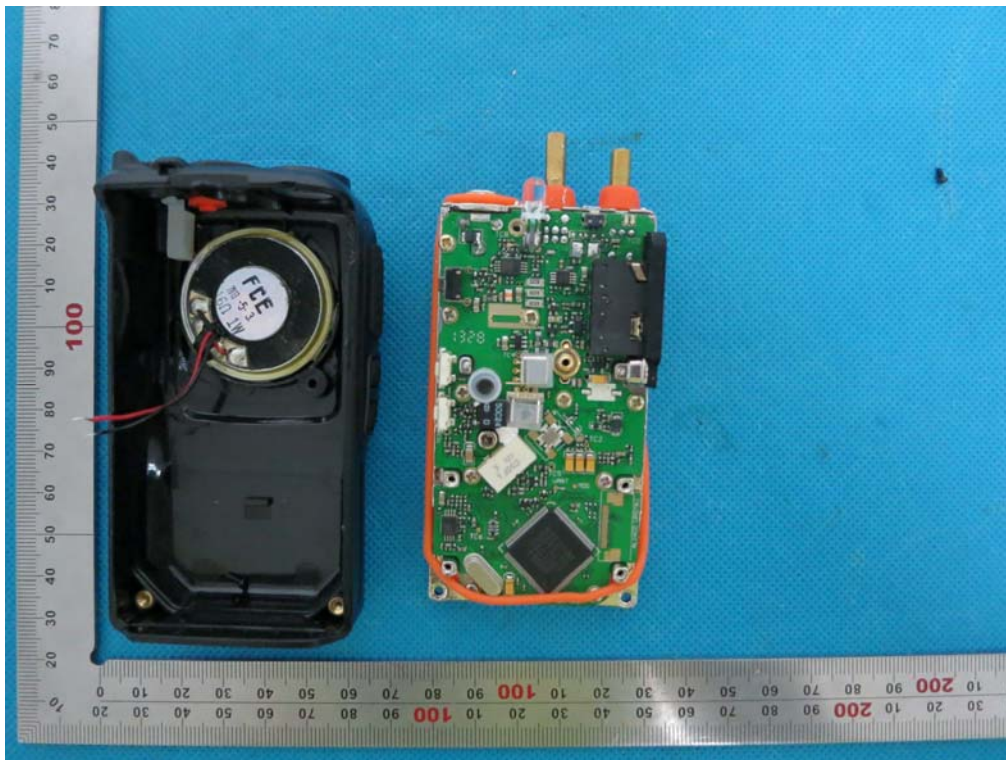

INTERNAL VIEW OF EUT - 1

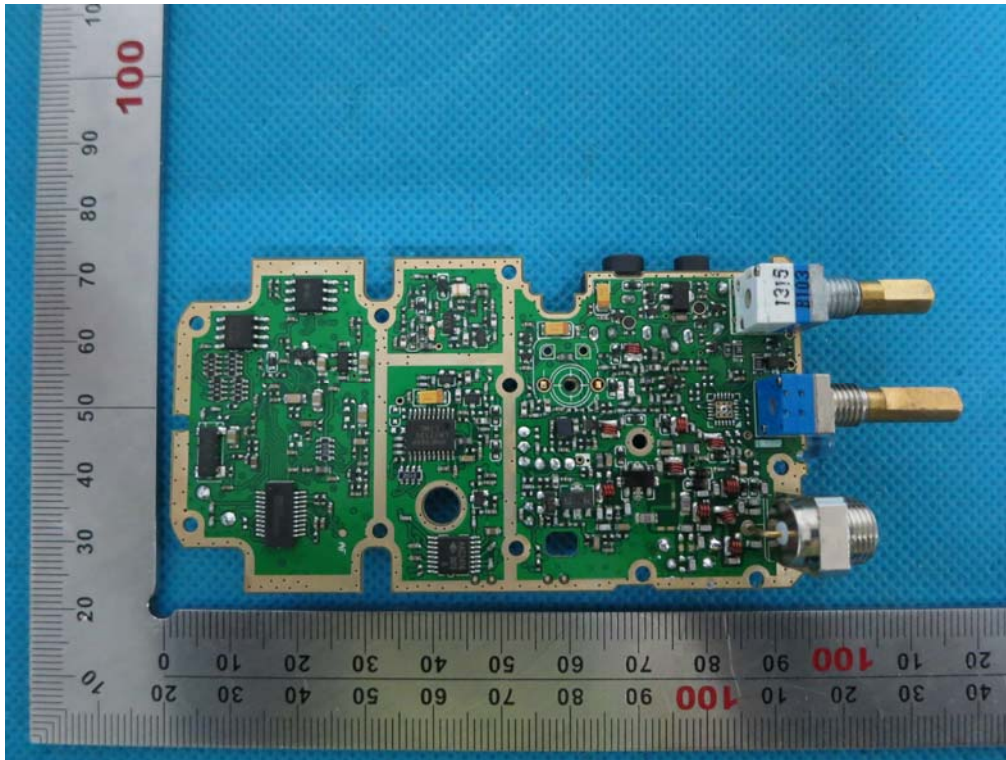

INTERNAL VIEW OF EUT - 2

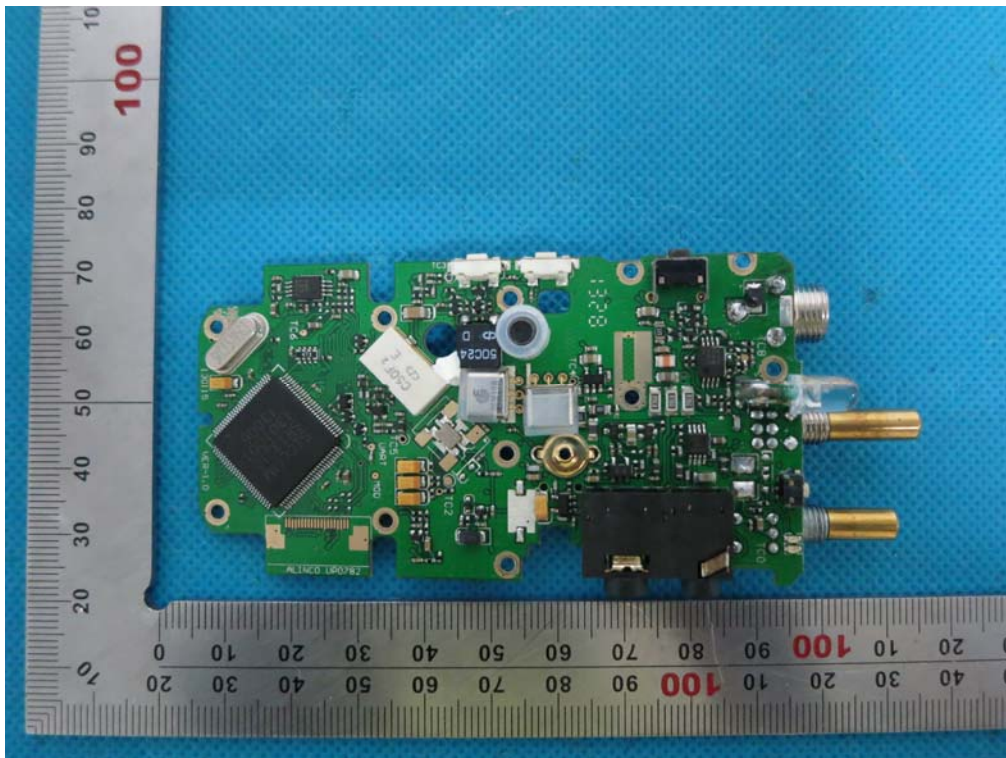

----END OF REPORT----