



SAR Test Report

Report No.: AGC00589140301FH01

FCC ID : PH3DJ-A41

APPLICATION PURPOSE : Original Equipment

Product Designation : UHF FM HANDHELD TRANSCEIVER

Brand Name : ALINCO

Model Name : DJ-A41

Client : Alinco Incorporated, Electronics Division

Date of Issue : May.13,2014

STANDARD(S) : IEEE Std. 1528:2003
47CFR § 2.1093
IEEE/ANSI C95.1

REPORT VERSION : V1.0

Attestation of Global Compliance (Shenzhen) Co., Ltd.



CAUTION:

This report shall not be reproduced except in full without the written permission of the test laboratory and shall not be quoted out of context.

Report Revise Record

Report Version	Revise Time	Issued Date	Valid Version	Notes
V1.0	/	May.13,2014	Valid	Original Report

Test Report Certification

Applicant Name	Alinco Incorporated, Electronics Division
Applicant Address	Yodoyabashi Dai-Bldg 13F, 4-4-9 Koraibashi, Chuo-Ku, Osaka 541-0043, Japan
Manufacturer Name	Alinco Incorporated, Electronics Division
Manufacturer Address	Yodoyabashi Dai-Bldg 13F, 4-4-9 Koraibashi, Chuo-Ku, Osaka 541-0043, Japan
Product Name	UHF FM HANDHELD TRANSCEIVER
Brand Name	ALINCO
Model Name	DJ-A41
Difference Description	N/A
EUT Voltage	DC7.4V by battery
Applicable Standard	IEEE Std. 1528:2003 47CFR § 2.1093 IEEE/ANSI C95.1
Test Date	May.13,2014
Performed Location	Attestation of Global Compliance (Shenzhen)Co., Ltd. 2F, Building 2, No.1-No.4, Chaxi Sanwei Technical Industrial Park, Gushu, Xixiang Street, Bao'an District, Shenzhen, China
Report Template	AGCRT-EC-PPT/SAR (2013-03-01)

Tested By

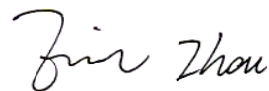

Eric Zhou May.13,2014

Checked By



Angela Li May.13,2014

Authorized By

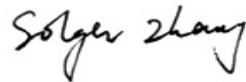

Solger Zhang May.13,2014

TABLE OF CONTENTS

1. SUMMARY OF MAXIMUM SAR VALUE	5
2. GENERAL INFORMATION	6
2.1. EUT Description	6
2.2. Test Procedure	7
2.3. Test Environment.....	7
3. SAR MEASUREMENT SYSTEM	8
3.1. Specific Absorption Rate (SAR)	8
3.2. SAR Measurement Procedure	9
3.3. COMOSAR System Description	10
3.4. COMOSAR E-Field Probe	12
3.5. Isotropic E-Field Probe Specification.....	12
3.6. Robot	12
3.7. Video Positioning System	13
3.8. Device Holder.....	13
3.9. Elliptic Phantom	14
4. TISSUE SIMULATING LIQUID.....	15
4.1. The composition of the tissue simulating liquid	15
4.2. Tissue Calibration Result	16
4.3. Tissue Dielectric Parameters for Head and Body Phantoms	17
5. SAR MEASUREMENT PROCEDURE	18
5.1. SAR System Validation Procedures	18
5.2. SAR System Validation.....	19
6. EUT TEST POSITION.....	21
6.1. Body Worn Position	21
7. SAR EXPOSURE LIMITS	22
8. TEST EQUIPMENT LIST	23
9. CONDUCTED POWER MEASUREMENT	24
10. TEST RESULTS	25
11.1. SAR Test Results Summary	25
APPENDIX A. SAR SYSTEM VALIDATION DATA	27
APPENDIX B. SAR MEASUREMENT DATA	29
APPENDIX C. TEST SETUP PHOTOGRAPHS &EUT PHOTOGRAPHS	37
APPENDIX D. PROBE CALIBRATION DATA	45
APPENDIX E. DIPOLE CALIBRATION DATA.....	55

1. SUMMARY OF MAXIMUM SAR VALUE

The maximum results of Specific Absorption Rate (SAR) found during testing for EUT are as follows:

Highest Report tested & scaled SAR Summary (with 50% duty cycle)

Exposure Position	Separation	Highest Reported 1g-SAR(W/Kg)	Highest Scaled Maximum SAR(W/Kg)
Face Up	12.5 KHz	2.597	2.688
Back Touch	12.5 KHz	7.077	7.326

This device is compliance with Specific Absorption Rate (SAR) for Occupational / Controlled Exposure Environment limits (8.0W/Kg) specified in FCC 47 CFR part 2 (2.1093) and ANSI/IEEE C95.1, and had been tested in accordance with measurement methods and procedures specified in IEEE 1528-2003 and the following specific FCC Test Procedures:

KDB 865664 D01 SAR Measurement 100MHz to 6GHz v01r03
KDB 643646 D01 SAR Test for PTT Radios V01r01

2. GENERAL INFORMATION

2.1. EUT Description

General Information	
Product Name	UHF FM HANDHELD TRANSCEIVER
Test Model	DJ-A41
Hardware Version	V1.00
Software Version	V2.02
Exposure Category:	Occupational/Controlled Exposure
Device Category	FM UHF Portable Transceiver
Modulation Type	FM
TX Frequency Range	400-470MHz
Rated Power	5Watt
Max. Average Power	37.0dBm
Channel Spacing	12.5 KHz
Antenna Type	External Antenna
Antenna Gain	2.15dBi
Body-Worn Accessories:	Belt Clip with headset
Face-Head Accessories:	None
Battery Type (s) Tested:	DC7.4V by battery

Note: The sample used for testing is end product.

2.2. Test Procedure

1	Setup the EUT for two typical configuration of hold to face and body worn individually
2	Power on the EUT and make it continuously transmitting on required operating channel
3	Make sure the EUT work normally during the test

2.3. Test Environment

Ambient conditions in the laboratory:

Items	Required	Actual
Temperature (°C)	18-25	21 ± 2
Humidity (%RH)	30-70	56

3. SAR MEASUREMENT SYSTEM

3.1. Specific Absorption Rate (SAR)

SAR is related to the rate at which energy is absorbed per unit mass in object exposed to a radio field. The SAR distribution in a biological body is complicated and is usually carried out by experimental techniques or numerical modeling. The standard recommends limits for two tiers of groups, occupational/controlled and occupational/uncontrolled, based on a person's awareness and ability to exercise control over his or her exposure. In general, occupational/controlled exposure limits are higher than the limits for general population/uncontrolled.

The SAR definition is the time derivative (rate) of the incremental energy (dW) absorbed by (dissipated in) an incremental mass (dm) contained in a volume (dv) of given mass density (ρ). The equation description is as below:

$$SAR = \frac{d}{dt} \left(\frac{dW}{dm} \right) = \frac{d}{dt} \left(\frac{dW}{\rho dV} \right)$$

SAR is expressed in units of Watts per kilogram (W/Kg)

SAR can be obtained using either of the following equations:

$$SAR = \frac{\sigma E^2}{\rho}$$

$$SAR = c_h \left. \frac{dT}{dt} \right|_{t=0}$$

Where

SAR	is the specific absorption rate in watts per kilogram;
E	is the r.m.s. value of the electric field strength in the tissue in volts per meter;
σ	is the conductivity of the tissue in siemens per metre;
ρ	is the density of the tissue in kilograms per cubic metre;
c_h	is the heat capacity of the tissue in joules per kilogram and Kelvin;

$\left. \frac{dT}{dt} \right|_{t=0}$ is the initial time derivative of temperature in the tissue in kelvins per second

3.2. SAR Measurement Procedure

The EUT is set to transmit at the required power in line with product specification, at each frequency relating to the LOW, MID, and HIGH channel settings.

Pre-scans are made on the device to establish the location for the transmitting antenna, using a large area scan in either air or tissue simulation fluid.

The EUT is placed against the Universal Phantom where the maximum area scan dimensions are larger than the physical size of the resonating antenna. When the scan size is not large enough to cover the peak SAR distribution, it is modified by either extending the area scan size in both the X and Y directions, or the device is shifted within the predefined area.

The area scan is then run to establish the peak SAR location (interpolated resolution set at 1mm^2) which is then used to orient the center of the zoom scan. The zoom scan is then executed and the 1g and 10g averages are derived from the zoom scan volume (interpolated resolution set at 1mm^3).

When multiple peak SAR location were found during the same configuration or test mode, Zoom scan shall performed on each peak SAR location, only the peak point with maximum SAR value will be reported for the configuration or test mode.

3.3. COMOSAR System Description

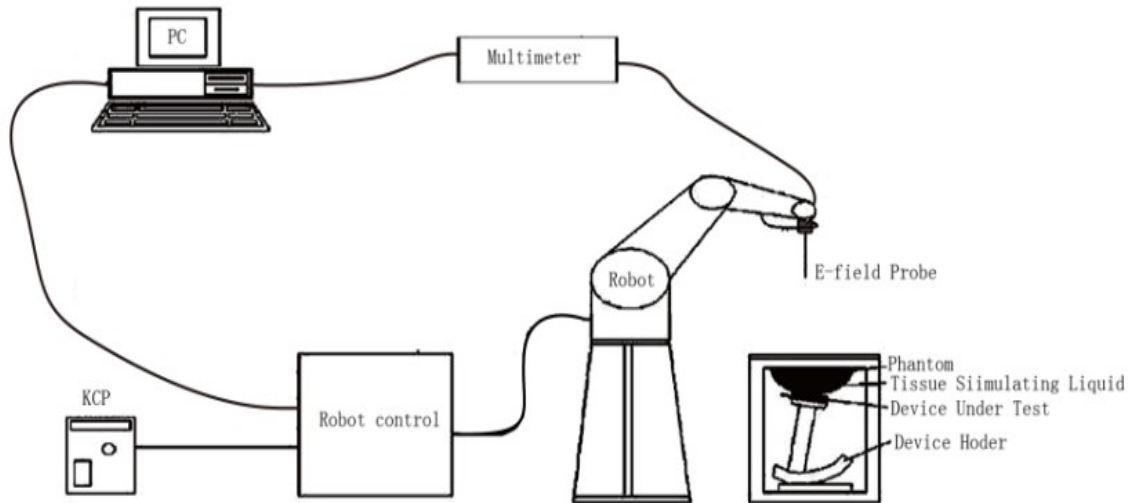

The COMOSAR system for performing compliance tests consists of the following items:

- The PC. It controls most of the bench devices and stores measurement data. A computer running WinXP and the Opensar software.
- The E-Field probe. The probe is a 3-axis system made of 3 distinct dipoles. Each dipole returns a voltage in function of the ambient electric field.
- The Keithley multimeter measures each probe dipole voltages.
- The SAM phantom simulates a human head. The measurement of the electric field is made inside the phantom.
- The liquids simulate the dielectric properties of the human head tissues.
- The network emulator controls the mobile phone under test.
- The validation dipoles are used to measure a reference SAR. They are used to periodically check the bench to make sure that there is no drift of the system characteristics over time.
- The phantom, the device holder and other accessories according to the targeted measurement.

3.3.1. Applications

Predefined procedures and evaluations for automated compliance testing with all worldwide standards, e.g., IEEE 1528, OET 65, IEC 62209-1, IEC 62209-2, EN 50360, EN 50383 and others.

3.3.2. Area Scans

Area scans are defined prior to the measurement process being executed with a user defined variable spacing between each measurement point (integral) allowing low uncertainty measurements to be conducted. Scans defined for FCC applications utilize a 10mm² step integral, with 1mm interpolation used to locate the peak SAR area used for zoom scan assessments. When an Area Scan has measured all reachable points, it computes the field maxima found in the scanned area, within a range of the global maximum. The range (in dB) is specified in the standards for compliance testing. For example, a 2 dB range is required in IEEE 1528-2003, EN 50361 and IEC 62209 standards, whereby 3 dB is a requirement when compliance is assessed in accordance with the ARIB standard (Japan).

3.3.3. Zoom Scan (Cube Scan Averaging)

Zoom Scans are used to assess the peak spatial SAR values within a cubic averaging volume containing 1 g and 10 g of simulated tissue. A density of 1000 kg/m³ is used to represent the head and body tissue density and not the phantom liquid density, in order to be consistent with the definition of the liquid dielectric properties, i.e. the side length of the 1 g cube is 10mm, with the side length of the 10 g cube 21,5mm. The zoom scan integer steps can be user defined so as to reduce uncertainty, but normal practice for typical test applications utilize a physical step of 7x7x7 (5mmx5mmx5mm) providing a volume of 30mm in the X & Y axis, and 30mm in the Z axis.

3.3.4. Uncertainty of Inter-/Extrapolation and Averaging

In order to evaluate the uncertainty of the interpolation, extrapolation and averaged SAR calculation algorithms of the Post processor, COMOSAR allows the generation of measurement grids which are artificially predefined by analytically based test functions. Therefore, the grids of area scans and zoom scans can be filled with uncertainty test data, according to the SAR benchmark functions of IEEE 1528. The three analytical functions shown in equations as below are used to describe the possible range of the expected SAR distributions for the tested handsets. The field gradients are covered by the spatially flat distribution f1, the spatially steep distribution f3 and f2 accounts for H-field cancellation on the phantom/tissue surface.

$$f_1(x, y, z) = A e^{-\frac{z}{2a}} \cos^2 \left(\frac{\pi}{2} \frac{\sqrt{x'^2 + y'^2}}{5a} \right)$$

$$f_2(x, y, z) = A e^{-\frac{z}{a}} \frac{a^2}{a^2 + x'^2} \left(3 - e^{-\frac{2z}{a}} \right) \cos^2 \left(\frac{\pi}{2} \frac{y'}{3a} \right)$$

$$f_3(x, y, z) = A \frac{a^2}{\frac{a^2}{4} + x'^2 + y'^2} \left(e^{-\frac{2z}{a}} + \frac{a^2}{2(a + 2z)^2} \right)$$

3.4. COMOSAR E-Field Probe

The SAR measurement is conducted with the dissymmetric probe manufactured by SATIMO. The probe is specially designed and calibrated for use in liquid with high permittivity. The dissymmetric probe has special calibration in liquid at different frequency. SATIMO conducts the probe calibration in compliance with international and national standards (e.g. IEEE 1528, EN62209-1, IEC 62209, etc.) Under ISO17025. The calibration data are in Appendix D.

3.5. Isotropic E-Field Probe Specification

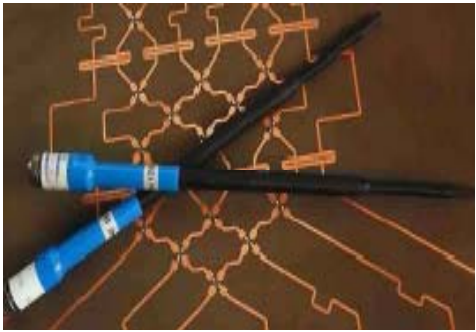
Model	SSE5	
Manufacture	SATIMO	
Frequency	0.3GHz-3 GHz Linearity:±0.09dB(300 MHz-3 GHz)	
Dynamic Range	0.01W/Kg-100W/Kg Linearity:±0.09dB	
Dimensions	Overall length:330mm Length of individual dipoles:4.5mm Maximum external diameter:8mm Probe Tip external diameter:5mm Distance between dipoles/ probe extremity:2.7mm	
Application	High precision dosimetric measurements in any exposure scenario (e.g., very strong gradient fields). Only probe which enables compliance testing for frequencies up to 3 GHz with precision of better 30%.	

3.6. Robot

<p>The COMOSAR system uses the KUKA robot from SATIMO SA (France).For the 6-axis controller COMOSAR system, the KUKA robot controller version from SATIMO is used. The XL robot series have many features that are important for our application:</p> <ul style="list-style-type: none"> High precision (repeatability 0.02 mm) High reliability (industrial design) Jerk-free straight movements Low ELF interference (the closed metallic construction shields against motor control fields) 6-axis controller 	
---	---

3.7. Video Positioning System

The video positioning system is used in OpenSAR to check the probe. Which is composed of a camera, LED, mirror and mechanical parts. The camera is piloted by the main computer with firewire link.

During the process, the actual position of the probe tip with respect to the robot arm is measured, as well as the probe length and the horizontal probe offset. The software then corrects all movements, such that the robot coordinates are valid for the probe tip.

The repeatability of this process is better than 0.1 mm. If a position has been taught with an aligned probe, the same position will be reached with another aligned probe within 0.1 mm, even if the other probe has different dimensions. During probe rotations, the probe tip will keep its actual position.

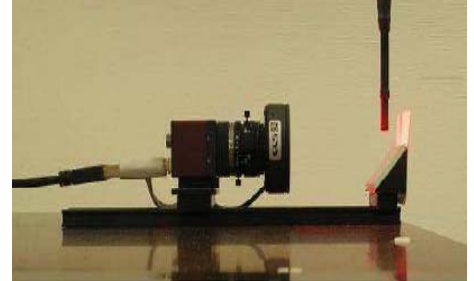

3.8. Device Holder

The COMOSAR device holder is designed to cope with different positions given in the standard. It has two scales for the device rotation (with respect to the body axis) and the device inclination (with respect to the line between the ear reference points). The rotation center for both scales is the ear reference point (EPR).

Thus the device needs no repositioning when changing the angles.

The COMOSAR device holder has been made out of low-loss POM material having the following dielectric parameters: relative permittivity $\epsilon_r = 3$ and loss tangent $\delta = 0.02$. The amount of dielectric material has been reduced in the closest vicinity of the device, since measurements have suggested that the influence of the clamp on the test results could thus be lowered.

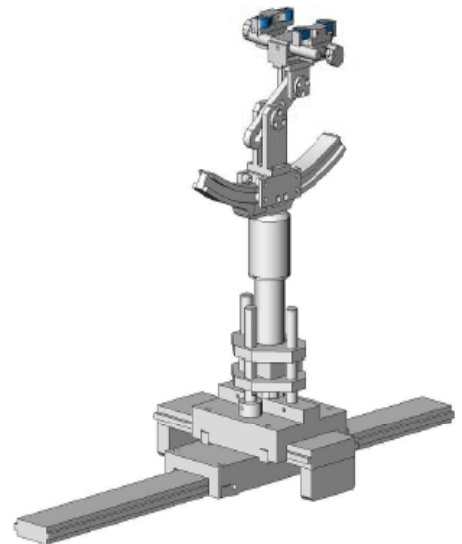

3.9. Elliptic Phantom

The Elliptic Phantom is a fiberglass shell flat phantom with 2mm+/- 0.2 mm shell thickness. It has only one measurement area for Flat phantom



4. TISSUE SIMULATING LIQUID

For SAR measurement of the field distribution inside the phantom, the phantom must be filled with homogeneous tissue simulating liquid to a depth of at least 15cm. For head SAR testing the liquid height from the ear reference point (ERP) of the phantom to the liquid top surface is larger than 15cm For body SAR testing, the liquid height from the center of the flat phantom to the liquid top surface is larger than 15cm. The nominal dielectric values of the tissue simulating liquids in the phantom and the tolerance of 5% are listed in 4.2

4.1. The composition of the tissue simulating liquid

Ingredient (% Weight) Tissue Type	450 MHz
Water	38.56
Salt (NaCl)	3.95
Sugar	56.32
HEC	0.98
Bactericide	0.19
Triton X-100	0.0
DGBE	0.0

4.2. Tissue Calibration Result

The dielectric parameters of the liquids were verified prior to the SAR evaluation using COMOSAR Dielectric Probe Kit and R&S Network Analyzer ZVL6 .

Tissue Stimulant Measurement for 450MHz							
Fr. (MHz)	Ch.	Dielectric Parameters ($\pm 5\%$)				Tissue Temp [$^{\circ}$ C]	Test time
		head		body			
		ϵ_r 43.50 41.325 to 45.675	δ [s/m] 0.87 0.8265 to 0.9135	ϵ_r 56.7 53.865 to 59.535	δ [s/m] 0.94 0.893 to 0.987		
450	Low	42.64	0.85	54.44	0.95	21	May.13,2014
450	Mid	44.05	0.90	55.16	0.93	21	May.13,2014
450	High	43.16	0.88	56.78	0.97	21	May.13,2014

4.3. Tissue Dielectric Parameters for Head and Body Phantoms

The head tissue dielectric parameters recommended by the IEEE SCC-34/SC-2 in P1528 have been incorporated in the following table. These head parameters are derived from planar layer models simulating the highest expected SAR for the dielectric properties and tissue thickness variations in a human head. Other head and body tissue parameters that have not been specified in P1528 are derived from the tissue dielectric parameters computed from the 4-Cole-Cole equations described in Reference [12] and extrapolated according to the head parameters specified in P1528.

Target Frequency (MHz)	head		body	
	ϵ_r	σ (S/m)	ϵ_r	σ (S/m)
300	45.3	0.87	58.2	0.92
450	43.5	0.87	56.7	0.94
835	41.5	0.90	55.2	0.97
900	41.5	0.97	55.0	1.05
915	41.5	0.98	55.0	1.06
1450	40.5	1.20	54.0	1.30
1610	40.3	1.29	53.8	1.40
1800 – 2000	40.0	1.40	53.3	1.52
2450	39.2	1.80	52.7	1.95
3000	38.5	2.40	51.6	2.73
5800	35.3	5.27	48.2	6.00

(ϵ_r = relative permittivity, σ = conductivity and $\rho = 1000 \text{ kg/m}^3$)

5. SAR MEASUREMENT PROCEDURE

5.1. SAR System Validation Procedures

Each SATIMO system is equipped with one or more system validation kits. These units, together with the predefined measurement procedures within the SATIMO software, enable the user to conduct the system performance check and system validation. System kit includes a dipole, and dipole device holder.

The system check verifies that the system operates within its specifications. It's performed daily or before every SAR measurement. The system check uses normal SAR measurement in the flat section of the phantom with a matched dipole at a specified distance. The system validation setup is shown as below.

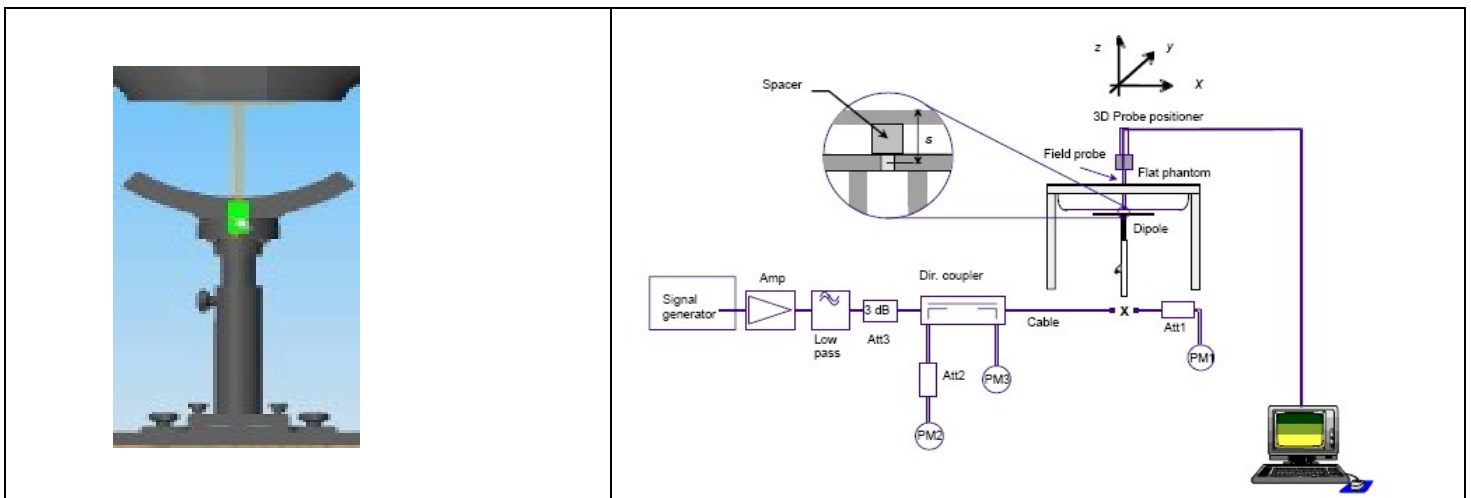

5.2. SAR System Validation

5.2.1. Validation Dipoles

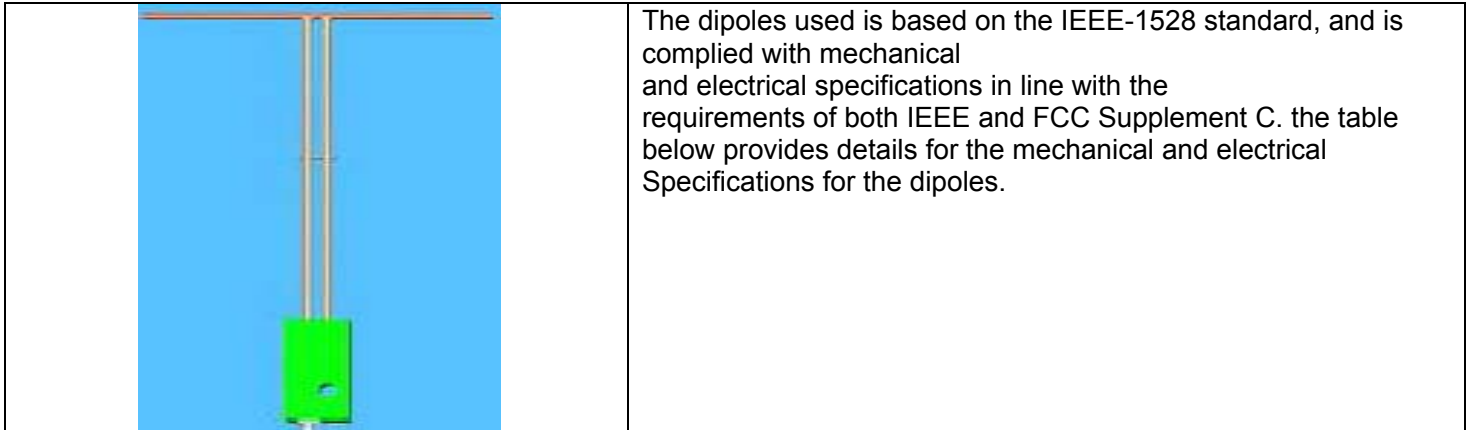

Frequency	L (mm)	h (mm)	d (mm)
450MHz	290	166.7	6.35

5.2.2. Validation Result

System Performance Check at 450MHz								
Validation Kit: SN 46/11DIP 0G450-184								
Frequency [MHz]	Target Value(W/Kg)		Reference Result ($\pm 10\%$)		Tested Value(W/Kg)		Tissue Temp. [°C]	Test time
	1g	10g	1g	10g	1g	10g		
450 body	5.07	3.25	4.563-5.577	2.925-3.575	4.90	3.17	21	May.13,2014

6. EUT TEST POSITION

This EUT was tested in **Front Face and Rear Face**.

6.1. Body Worn Position

- (1) To position the EUT parallel to the phantom surface.
- (2) To adjust the EUT parallel to the flat phantom.
- (3) To adjust the distance between the EUT surface and the flat phantom to **25mm**.

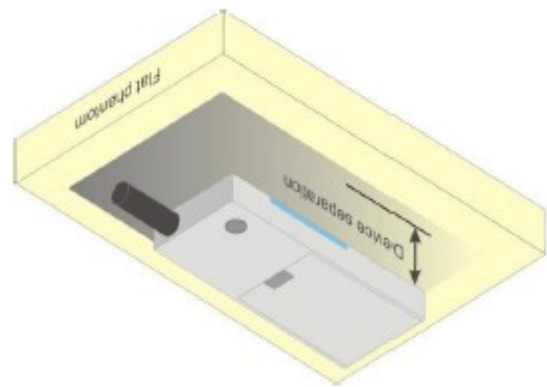
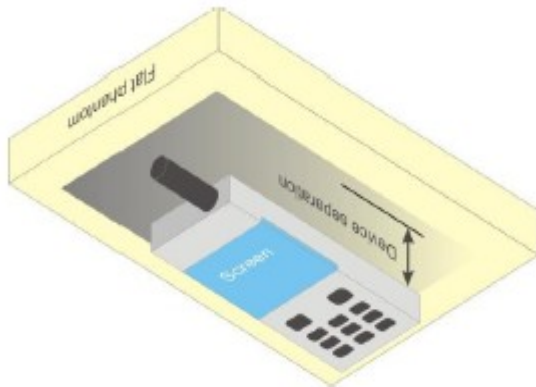

7. SAR EXPOSURE LIMITS

SAR assessments have been made in line with the requirements of IEEE-1528, FCC Supplement C, and comply with ANSI/IEEE C95.1-1992 "Controlled Exposure Environment" limits. These limits apply to a location which is deemed as "Controlled Exposure Environment" which can be described as a situation where the general public may be exposed to an RF source with no prior knowledge or control over their exposure.

Limits for Occupational / Controlled Exposure Environment

Type Exposure Limits	Occupational / Controlled Exposure Environment(W/Kg)
Spatial Average SAR (whole body)	8.0

8. TEST EQUIPMENT LIST

Equipment description	Manufacturer/Model	Identification No.	Current calibration date	Next calibration date
SAR Probe	SATIMO	SN 22/12 EP159	01/12/2014	01/11/2015
Phantom	SATIMO	SN_4511_SAM90	Validated. No cal required.	Validated. No cal required.
Liquid	SATIMO	-	Validated. No cal required.	Validated. No cal required.
Comm Tester	R&S - CMU200	069Y7-158-13-712	02/17/2014	02/16/2015
Comm Tester	Agilent-8960	GB46310822	02/17/2014	02/16/2015
Multimeter	Keithley 2000	1188656	02/17/2014	02/16/2015
Dipole	SATIMO SID450	SN46/11 DIP 0G450-184	11/14/2013	11/13/2015
Amplifier	Aethercomm	SN 046	12/08/2013	12/07/2014
Signal Generator	Agilent-E4438C	MY44260051	02/23/2014	02/22/2015
Power Probe	NRP-Z23	US38261498	02/17/2014	02/16/2015
SPECTRUM ANALYZER	Agilent/E4440A	MY44303916	10/22/2013	10/21/2014
Power Attenuator	BED	DLA-5W	07/30/2013	07/29/2014
Network Analyzer	Rhode & Schwarz ZVA	SN100132	02/17/2014	02/16/2015

Note: Per KDB 50824 Dipole SAR Validation Verification, AGC Lab has adopted 3 years calibration intervals. On annual basis, every measurement dipole has been evaluated and is in compliance with the following criteria:

1. There is no physical damage on the dipole;
2. System validation with specific dipole is within 10% of calibrated value;
3. Return-loss is within 20% of calibrated measurement;
4. Impedance is within 5Ω of calibrated measurement.

9. CONDUCTED POWER MEASUREMENT

Frequency (MHz)	Channel Spacing	Measured Conducted Output power	
		Max. Peak Power (dBm)	Avg. Power (dBm)
400.225	12.5KHz	37.14	37.00
440.875		37.12	37.00
469.975		37.15	37.00

10. TEST RESULTS

11.1. SAR Test Results Summary

11.1.1. Test position and configuration

Head SAR was performed with the device configured in the positions according to KDB 643646 and Body SAR was performed with the device configured with all accessories close to the Flat Phantom.

11.1.2. Operation Mode

Set the EUT to maximum output power level and transmit on lower, middle and top channel with 100% duty cycle individually during SAR measurement.

11.1.3. Co-located SAR

The following KDB was used for assessing this device.

KDB 643646 and KDB 865664.

10.1.4. Test Result

SAR MEASUREMENT										
Ambient Temperature (°C) : 21 ±2				Ambient Temperature (°C) : 21 ±2						
Liquid Temperature (°C) : 21 ±2				Liquid Temperature (°C) : 21 ±2						
Product: UHF FM HANDHELD TRANSCEIVER										
Test Mode: Hold to Face with 2.5 cm separation and Body worn with all accessories (UHF)										
Position	Mode	Separation (KHz)	Power Drift (<±5%)	SAR 1g with 100% duty Cycle (W/kg)*1	SAR 1g with 50% duty cycle (W/Kg)*2	SAR 1g with 50% duty cycle (W/Kg)*3	Max. Turn-up Power (dBm)	Meas. output Power (dBm)	Scaled SAR (W/Kg)	Limit W/kg
Face Up	Top	12.5	-0.77	2.597	1.299	2.597	37.15	37.00	2.688	8.0
Back Touch	Low	12.5	0.59	6.426	3.213	6.426	37.14	37.00	6.637	8.0
Back Touch	Mid.	12.5	-0.42	6.527	3.264	6.527	37.12	37.00	6.710	8.0
Back Touch	Top	12.5	-2.01	7.077	3.539	7.077	37.15	37.00	7.326	8.0
Note:										
*1 During the test, EUT power is 2.5 W with 100% duty cycle;										
*2 Calculated the SAR value(2.5W) with 50% duty cycle according to *1;										
*3 Calculated the SAR value(5W) with 50% duty cycle according to *2;										

APPENDIX A. SAR SYSTEM VALIDATION DATA

Test Laboratory: AGC Lab
System Check Body 450MHz

Date: May.13,2014

DUT: Dipole 450 MHz Type: SID 450

Communication System: CW; Communication System Band: CW 450 MHz; Duty Cycle: 1:1; Conv.F=4.83
Frequency: 450MHz; Medium parameters used: $f = 450$ MHz; $\sigma = 0.93$ mho/m; $\epsilon_r = 55.16$; $\rho = 1000$ kg/m³ ;
Phantom Type: Elliptical Phantom; Input Power=10dBm
Ambient temperature (°C): 21.0, Liquid temperature (°C): 21.0

SATIMO Configuration:

- Probe: SSE5; Calibrated: 01/12/2014; Serial No.:SN22/12 EP159
- Sensor-Surface: 4mm (Mechanical Surface Detection)
- Phantom: Flat Phantom; Type: Elliptical Phantom
- Measurement SW: OpenSAR V4_02_0

Configuration/System Check CW 450 MHz Body/Area Scan: Measurement grid: dx=8mm,dy=8mm
Configuration/System Check CW 450 MHz Body/Zoom Scan : Measurement grid: dx=8mm,
dy=8mm, dz=5mm,

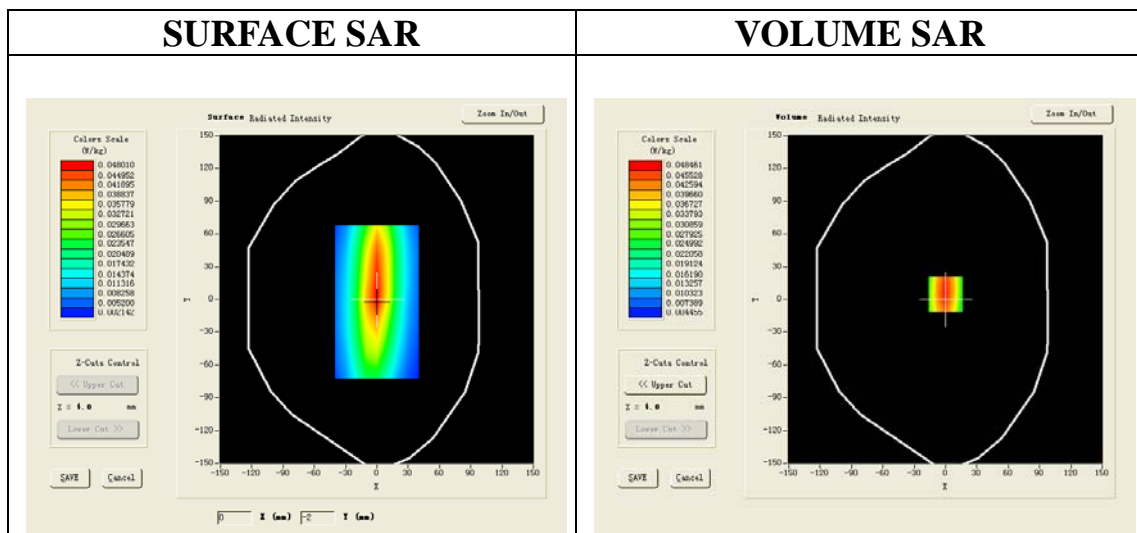

Maximum location: X=0.00, Y=5.00

SAR 10g (W/Kg)	0.031719
SAR 1g (W/Kg)	0.048958

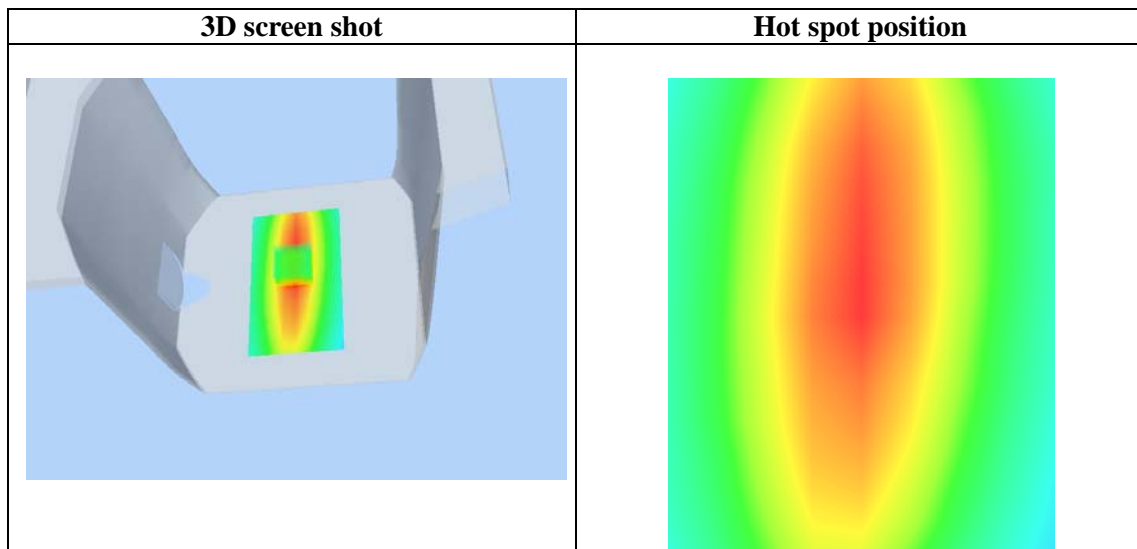
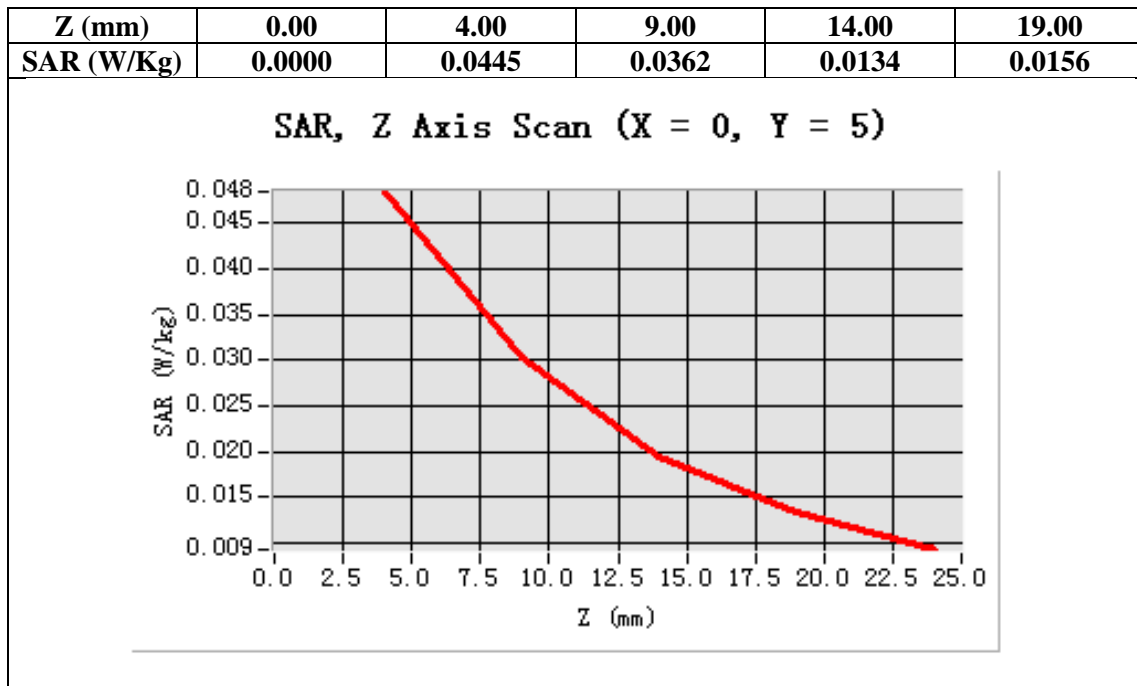

APPENDIX B. SAR MEASUREMENT DATA

Test Laboratory: AGC Lab

Date: May.13,2014

CW450 High- Face up 2.5 cm separation (12.5 KHz)

DUT: UHF FM HANDHELD TRANSCEIVER; Type: DJ-A41

Communication System: CW; Communication System Band: CW 450 MHz; Duty Cycle: 1:1; Conv.F=4.71

Frequency: 469.975MHz; Medium parameters used: $f = 450$ MHz; $\sigma = 0.88$ mho/m; $\epsilon_r = 43.16$; $\rho = 1000$ kg/m³ ;

Phantom Type: Elliptical Phantom

Ambient temperature (°C): 21.5, Liquid temperature (°C): 21.0

SATIMO Configuration:

- Probe: SSE5; Calibrated: 01/12/2014; Serial No.:SN22/12 EP159
- Sensor-Surface: 4mm (Mechanical Surface Detection)
- Phantom: Flat Phantom; Type: Elliptical Phantom
- Measurement SW: OpenSAR V4_02_0

Configuration/CW 450 for High head/Area Scan (6x8x1): Measurement grid: dx=8mm, dy=8mm

Configuration/CW 450 for High head/Zoom Scan (5x5x7)/Cube 0: Measurement grid: dx=8mm, dy=8mm,dz=5mm;

Area Scan	ep_direct_droit2_surf8mm.txt
ZoomScan	5x5x7,dx=8mm dy=8mm dz=5mm,Very fast
Phantom	Elliptical Phantom
Device Position	Face up 2.5 cm separation to Phantom
Band	CW 450
Channels	High
Signal	Crest factor: 1

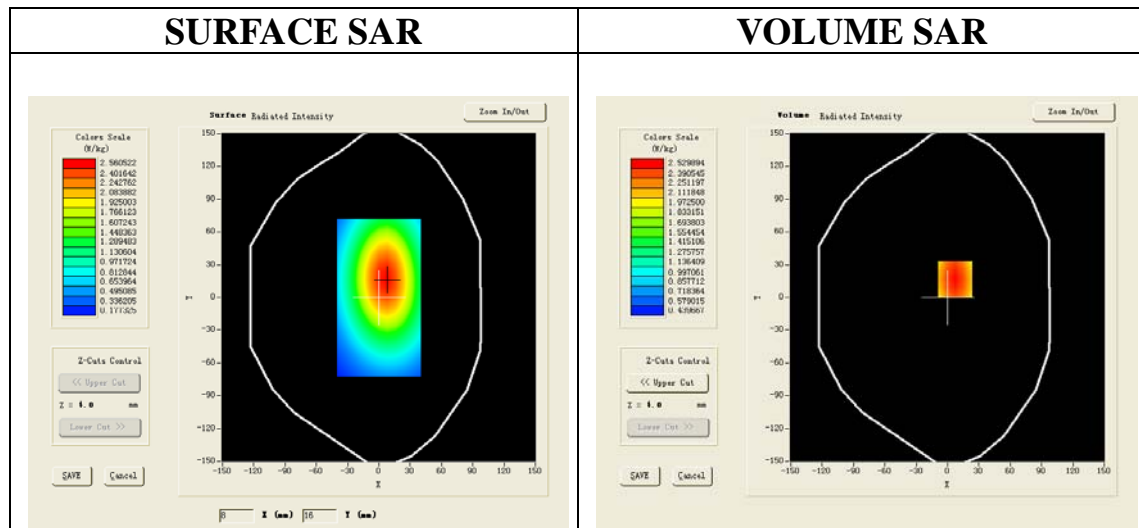

Maximum location: X=7.00, Y=17.00

SAR 10g (W/Kg)	1.746456
SAR 1g (W/Kg)	2.596917

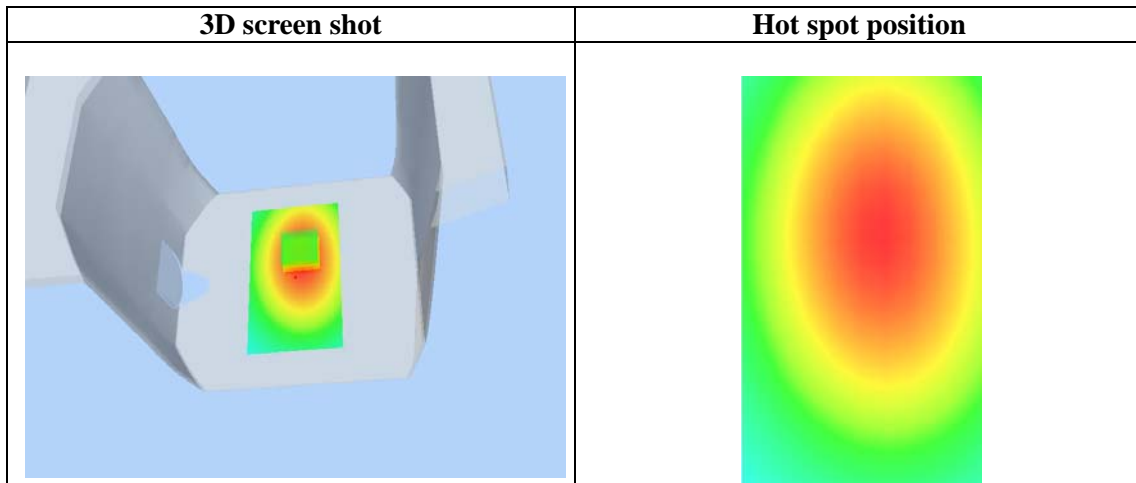
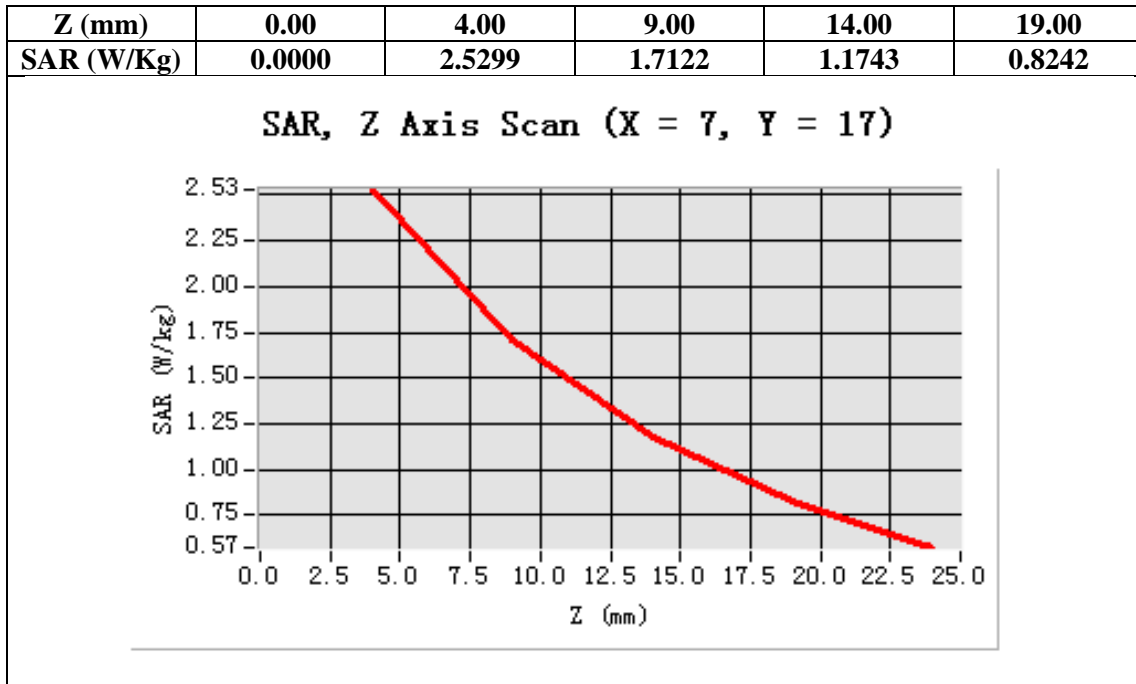

Test Laboratory: AGC Lab
CW450 Low -Body -Touch (12.5 KHz)

Date: May.13,2014

DUT: UHF FM HANDHELD TRANSCEIVER; Type: DJ-A41

Communication System: CW; Communication System Band: CW 450 MHz; Duty Cycle: 1:1; Conv.F=4.83
Frequency: 400.225MHz; Medium parameters used: $f = 450$ MHz; $\sigma = 0.95$ mho/m; $\epsilon_r = 54.44$; $\rho = 1000$ kg/m³ ;
Phantom Type: Elliptical Phantom
Ambient temperature (°C): 21.5, Liquid temperature(°C): 21.0

SATIMO Configuration:

- Probe: SSE5; Calibrated: 01/12/2014; Serial No.:SN22/12 EP159
- Sensor-Surface: 4mm (Mechanical Surface Detection)
- Phantom: Flat Phantom; Type: Elliptical Phantom
- Measurement SW: OpenSAR V4_02_0

Configuration/CW 450 for Low Touch/Area Scan: Measurement grid: dx=8mm, dy=8mm
Configuration/CW 450 for Low Touch/Zoom Scan: Measurement grid: dx=8mm,
dy=8mm, dz=5mm,

Area Scan	ep_direct_droit2_surf8mm.txt
ZoomScan	5x5x7,dx=8mm dy=8mm dz=5mm,Very fast
Phantom	Elliptical Phantom
Device Position	Back close to Phantom with Accessories
Band	CW 450
Channels	Low
Signal	Crest factor: 1

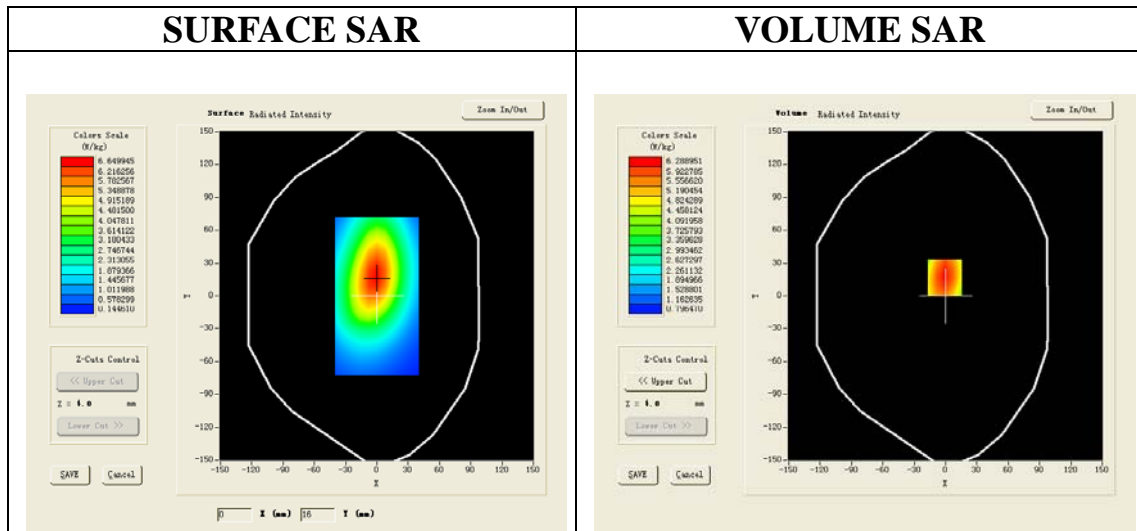

Maximum location: X=-1.00, Y=17.00

SAR 10g (W/Kg)	4.135474
SAR 1g (W/Kg)	6.426163

Z (mm)	0.00	4.00	9.00	14.00	19.00
SAR (W/Kg)	0.0000	6.2890	4.0793	2.6887	1.8288

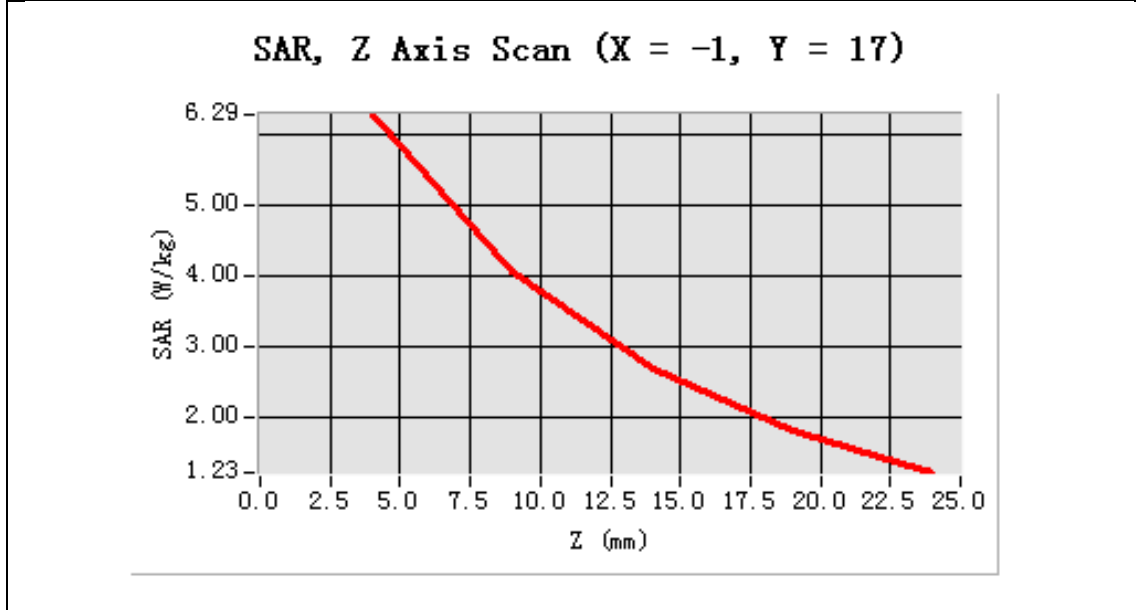

3D screen shot	Hot spot position
<p>A 3D perspective view of a grey, rectangular device. A small, localized area on the front face is highlighted with a color gradient from red (high SAR) to green and blue (low SAR), indicating the position of the maximum SAR value.</p>	<p>A 2D heatmap showing the SAR distribution on the device's surface. The color scale ranges from red (highest SAR) in the center to green and blue (lowest SAR) towards the edges, forming an oval-shaped hot spot.</p>

Test Laboratory: AGC Lab
CW450 Mid -Body –Touch (12.5 KHz)

Date: May.13,2014

DUT: UHF FM HANDHELD TRANSCEIVER; Type: DJ-A41

Communication System: CW; Communication System Band: CW 450 MHz; Duty Cycle: 1:1; Conv.F=4.83
Frequency: 440.875 MHz; Medium parameters used: $f = 450$ MHz; $\sigma = 0.93$ mho/m; $\epsilon_r = 55.16$; $\rho = 1000$ kg/m³ ;
Phantom Type: Elliptical Phantom
Ambient temperature (°C): 21.5, Liquid temperature(°C): 21.0

SATIMO Configuration:

- Probe: SSE5; Calibrated: 01/12/2014; Serial No.:SN22/12 EP159
- Sensor-Surface: 4mm (Mechanical Surface Detection)
- Phantom: Flat Phantom; Type: Elliptical Phantom
- Measurement SW: OpenSAR V4_02_0

Configuration/CW 450 for Mid Touch/Area Scan: Measurement grid: dx=8mm, dy=8mm

Configuration/CW 450 for Mid Touch/Zoom Scan: Measurement grid: dx=8mm, dy=8mm, dz=5mm,

Area Scan	ep_direct_droit2_surf8mm.txt
ZoomScan	5x5x7,dx=8mm dy=8mm dz=5mm,Very fast
Phantom	Elliptical Phantom
Device Position	Back close to Phantom with Accessories
Band	CW 450
Channels	Middle
Signal	Crest factor: 1

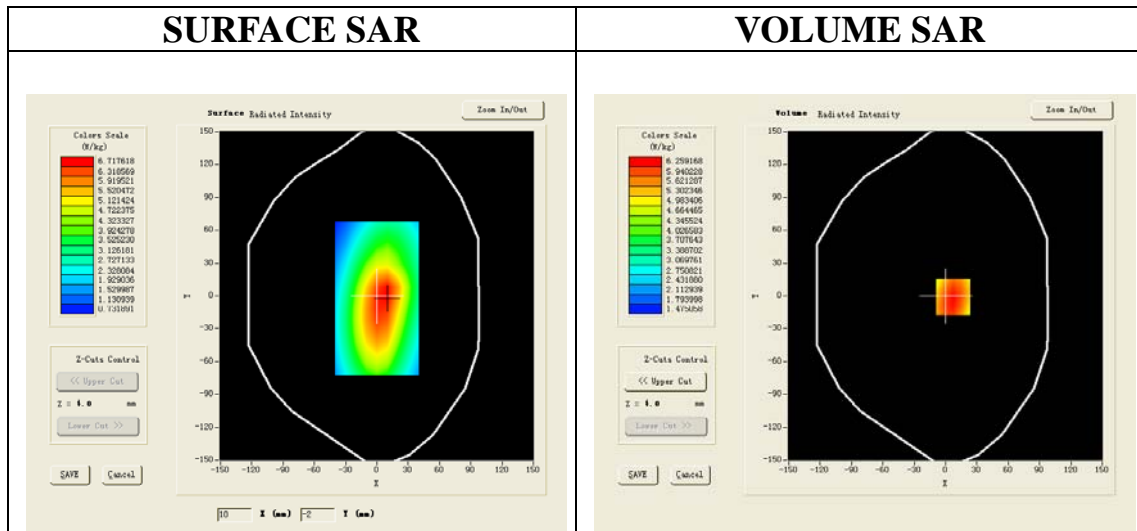

Maximum location: X=7.00, Y=-1.00

SAR 10g (W/Kg)	4.693327
SAR 1g (W/Kg)	6.526811

Z (mm)	0.00	4.00	9.00	14.00	19.00
SAR (W/Kg)	0.0000	6.2590	4.6389	3.4623	2.6214

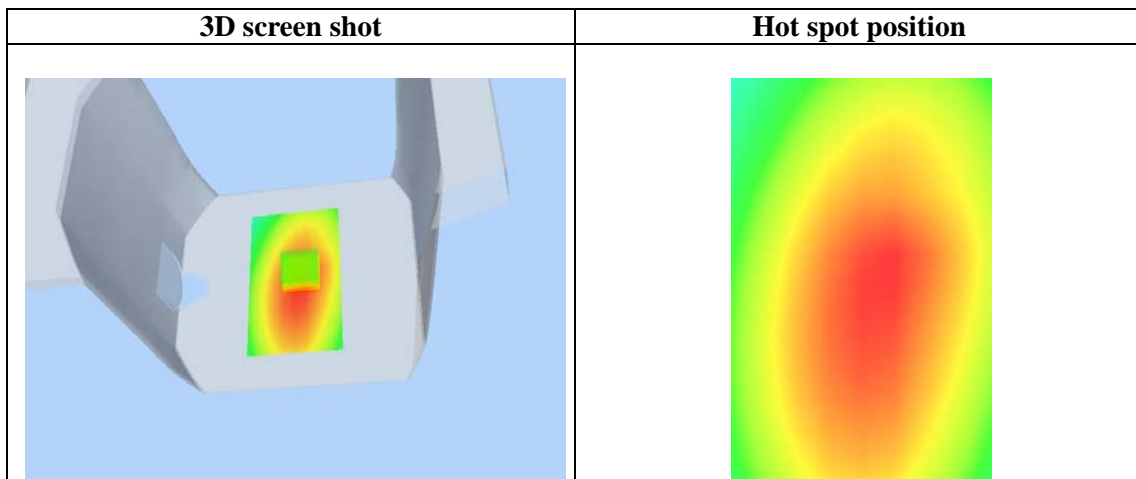
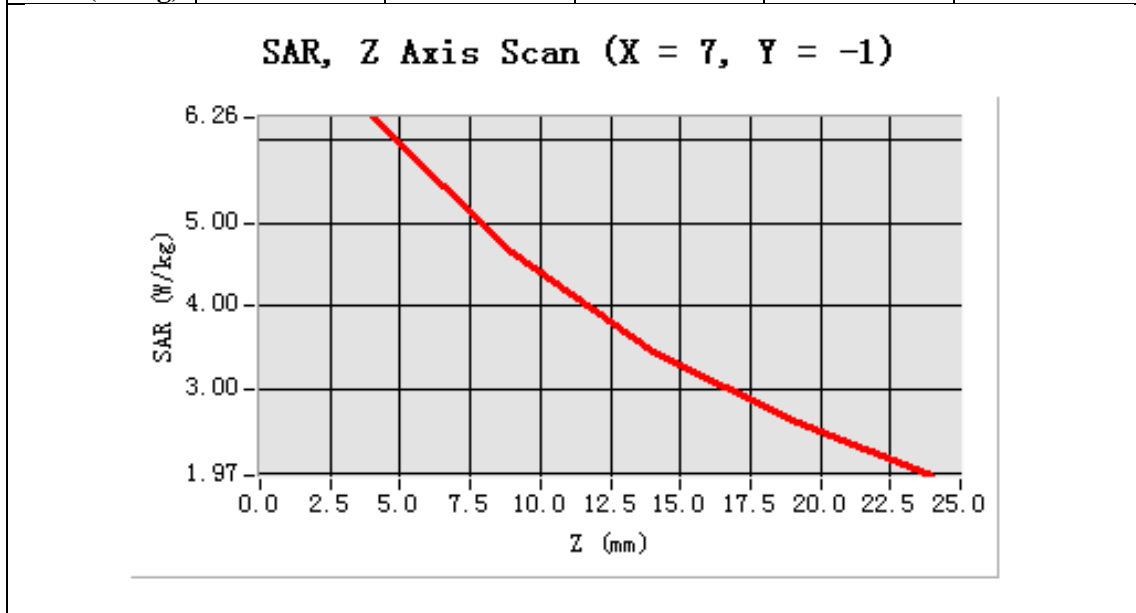

Test Laboratory: AGC Lab
CW450 High -Body –Touch (12.5 KHz)
DUT: UHF FM HANDHELD TRANSCEIVER; Type: DJ-A41

Date: May.13,2014

Communication System: CW; Communication System Band: CW 450 MHz; Duty Cycle: 1:1; Conv.F=4.83
Frequency: 469.975MHz; Medium parameters used: $f = 450$ MHz; $\sigma = 0.97$ mho/m; $\epsilon_r = 56.78$; $\rho = 1000$ kg/m³ ;
Phantom Type: Elliptical Phantom
Ambient temperature (°C): 21.5, Liquid temperature(°C): 21.0

SATIMO Configuration:

- Probe: SSE5; Calibrated: 01/12/2014; Serial No.:SN22/12 EP159
- Sensor-Surface: 4mm (Mechanical Surface Detection)
- Phantom: Flat Phantom; Type: Elliptical Phantom
- Measurement SW: OpenSAR V4_02_0

Configuration/CW 450 for High Touch/Area Scan: Measurement grid: dx=8mm, dy=8mm
Configuration/CW 450 for High Touch/Zoom Scan: Measurement grid: dx=8mm, dy=8mm, dz=5mm,

Area Scan	ep_direct_droit2_surf8mm.txt
ZoomScan	5x5x7,dx=8mm dy=8mm dz=5mm,Very fast
Phantom	Elliptical Phantom
Device Position	Back close to Phantom with Accessories
Band	CW 450
Channels	High
Signal	Crest factor: 1

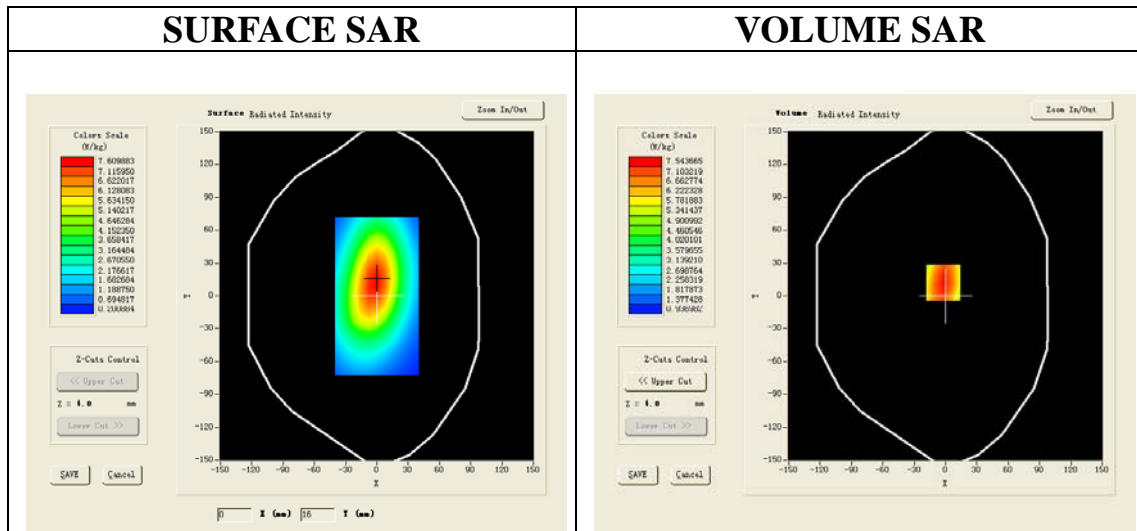

Maximum location: X=-2.00, Y=12.00

SAR 10g (W/Kg)	4.939133
SAR 1g (W/Kg)	7.707727

