

FCC Technical report

**Technical Report – TR-419-15-006 V1.0
March 15, 2001**

Table of Contents

Executive Summary	3
2.1033.....	4
a) Application for Certification	4
b) Application for Equipment Parts 11, 15, and 18.....	4
c) Application for Equipment other than Parts 15 and Parts 18.....	4
(1) Name and Address of Manufacturer.....	4
(2) FCC Identifier.....	4
(3) Installation Manual	4
(4) Types of Emission	4
(5) Frequency range	4
(6) Power Range.....	5
(7) Maximum Power	5
(8) DC voltages and Currents.....	5
(9) Tune up Procedure.....	8
10) Schematics and descriptions	10
(11) Photographs of Equipment Identification.....	14
(12) Photographs of Equipment	17
(13) Digital Modulation.....	23
(14) Data Required by 2.1046 through 2.1057.....	24
(15) Certification under Part 97	25
(16) Certification of AM broadcast.....	25
(17) Application for Composite System.....	25
Annex A	26
Annex B.....	31
Annex C.....	33

Executive Summary

This document contains all the information to comply with section 2.1033 “Application for Certification” of the FCC document.

2.1033

a) Application for Certification

FCC form 731 was already filed.

b) Application for Equipment Parts 11, 15, and 18

The Pro-Find 406 does not fall under parts 11, 15 or 18 so nothing is required here.

c) Application for Equipment other than Parts 15 and Parts 18

(1) Name and Address of Manufacturer

Seimac Limited
271 Brownlow Ave
Dartmouth, Nova Scotia, Canada
B3B 1W6

(2) FCC Identifier

FCC ID:	PGSEPIRB
Applicant:	PRO-Find Safety Incorporated
Correspondence Reference Number:	18401
731 Confirmation Number:	EA99871

(3) Installation Manual

The installation Manual is in Annex C

(4) Types of Emission

- i) 121.5 MHz -- 3K20A3N
- ii) 406 MHz -- 16K0G1D

(5) Frequency range

- i) 406.028 MHz +/- .001 MHz
- ii) 121.5 MHz +/- .003 MHz

(6) Power Range

- i) 406.028 MHz 5W +/- 2dB (3.15 W to 7.92 W)

Power output has been designed for one power level of 5W. Some variation in the components will cause this power to vary but the power shall remain within the specification for this device. This is verified during testing. There are no means provided for power output level adjustment by the user.

- ii) 121.5 MHz 25 mW -0dB +6dB (25 mW to 100 mW)

Power output has been designed for one power level of 50 mW. Some variation in the components will cause this power to vary but the power shall remain within the specification for this device. This is verified during testing. There are no means provided for power output level adjustment by the user.

(7) Maximum Power

- i) 406.028 MHz 7.92 W
- ii) 121.5 MHz 100 mW

(8) DC voltages and Currents

Note all the currents given in this section are Continuous Wave currents and only represent the currents when the devices are ON. The EPRIB specification requires that the output be pulsed on and off so the average current is much less than the ON current.

- i) DC voltages and current into the Power Amplifier and Exciter for the 406.028 MHz transmitter are indicated in Figure 1 and Table 1.

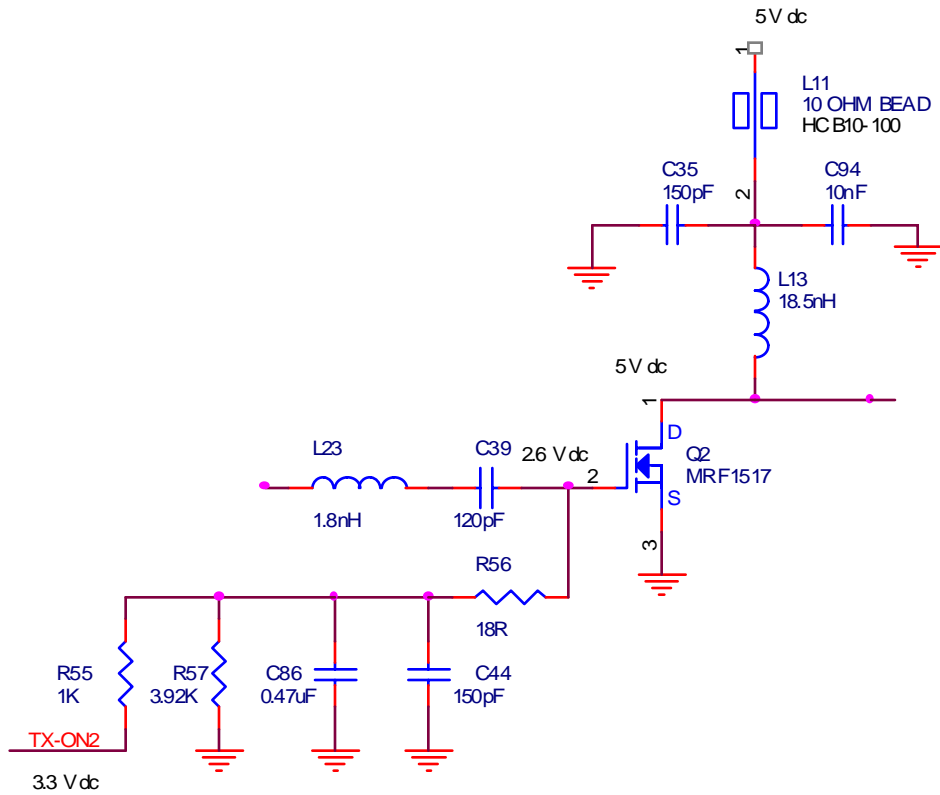

Figure 1. Schematic Showing DC Voltages into the Power Amplifier

Pin	DC Voltage	Current
Vd	5 V	1.8 A
Vg	2.6 V	.3 nA

Table 1. DC Voltage and Current of Final PA

The dc voltages and current into the exciter for the Power Amplifier are as indicated in Table 2 and Figure 2.

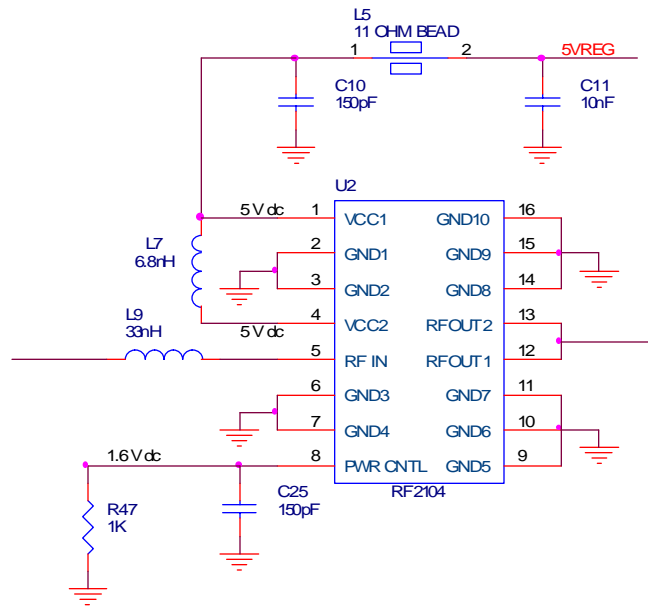

Figure 2. Schematic Showing DC Voltages into Exciter

Pin	DC Voltage	Current
Vcc1	5 V	.03A
Vcc2	5 V	.26A
PWRCNTL	1.6 V	.6 mA

Table 2. DC Voltages and Current into the Exciter

- ii) DC voltages and currents into the 121.5 MHz Amplifier are indicated in Table 3 and Figure 3.

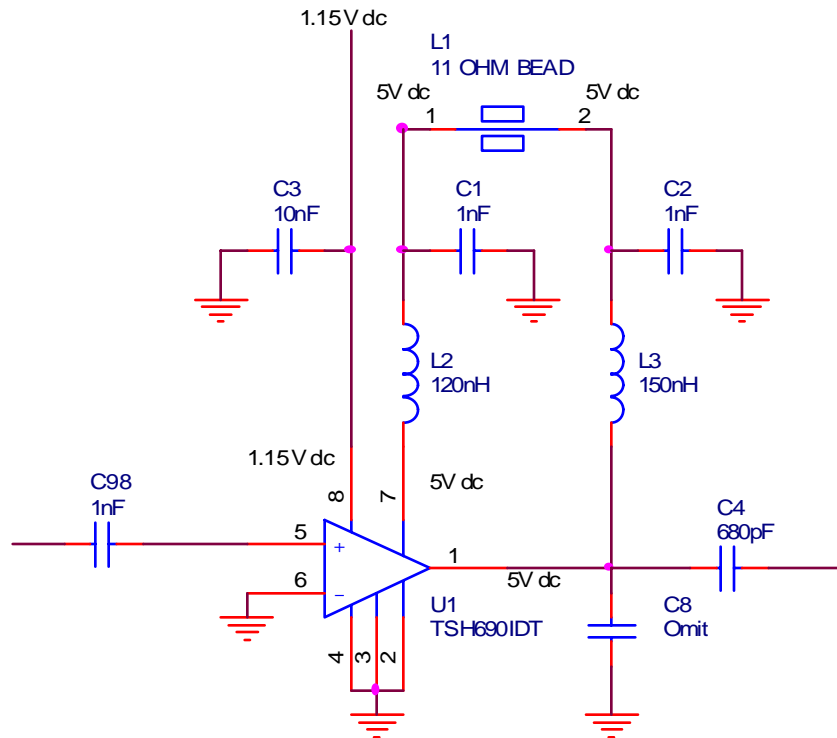

Figure 3. Schematic Showing DC Voltages into the 121.5 MHz Amplifier

Pin	DC Voltage	Current
Pin 7/Pin 1	5 V	95 mA
Pin 8	1.15 V	1.75 mA

Table 3. DC Voltages into the 121.5 MHz Amplifier

(9) Tune up Procedure

The Pro-Find 406 will transmit at only one power level for each frequency. The unit is tuned at the manufacturer’s facility. Users are unable to adjust any power level.

- i) 406.028 MHz 5 W
- ii) 121.5 MHz 50 mW

The Tune up Procedure is indicated in Flow Chart 1.

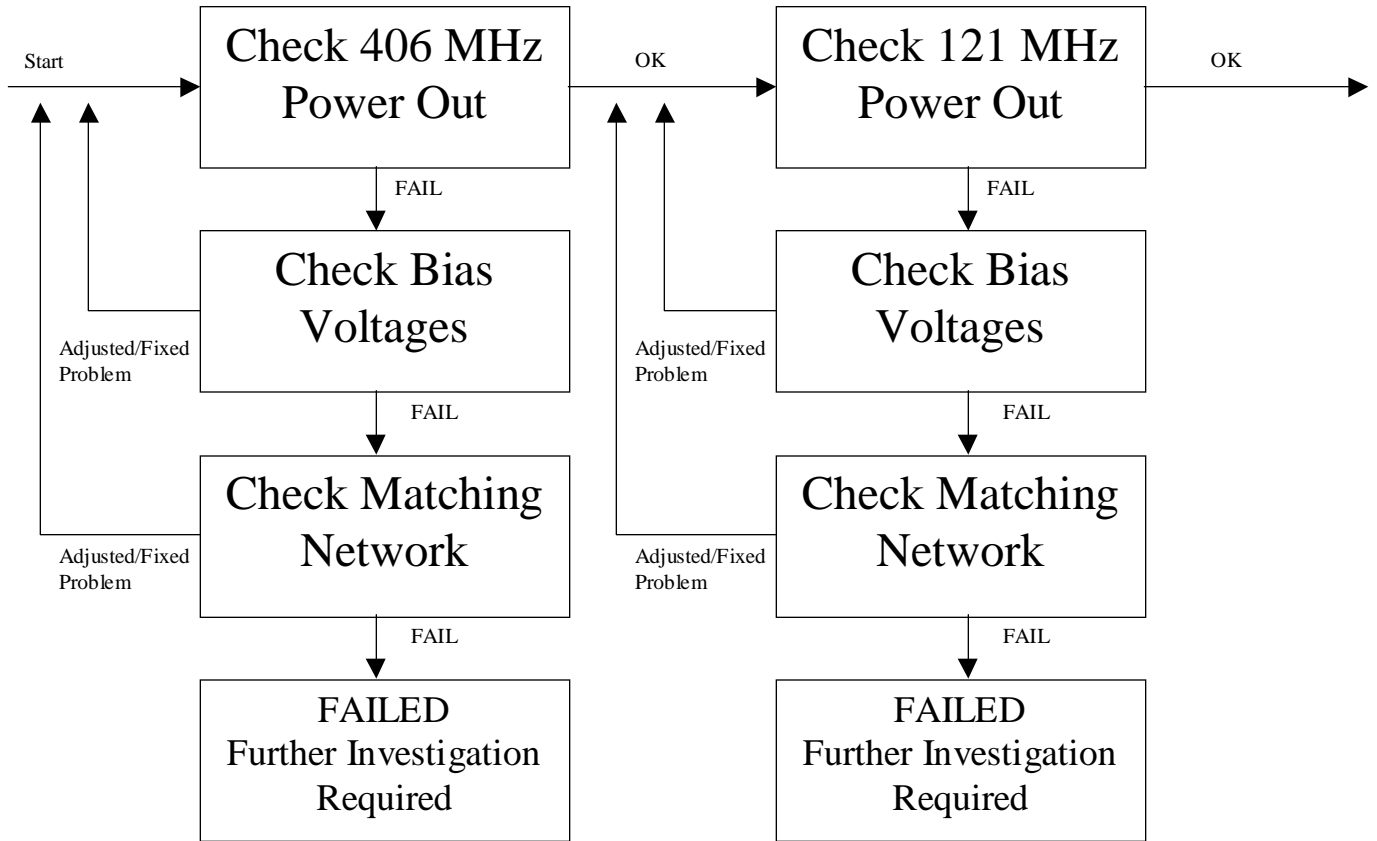

Flow Chart 1. Tune up Procedures

10) Schematics and descriptions

- i) The circuit in Figure 4 is used to determine, stabilize and modulate the 406.028 MHz frequency.

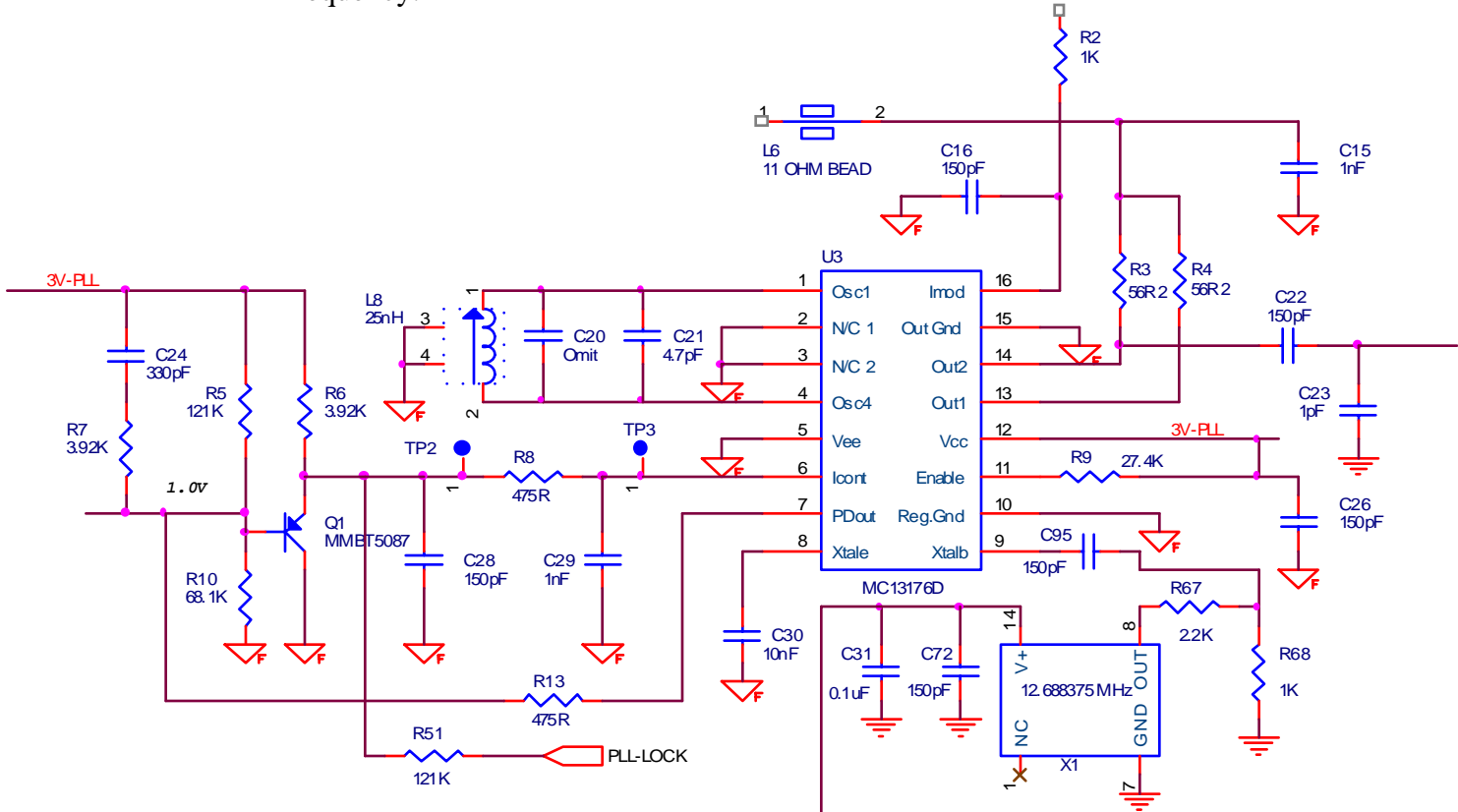

Figure 4. PLL , OCXO and Modulator for 406.028 MHz

The circuit consists of the following

- MC13176D UHF FM/AM transmitter

The MC13176D includes a UHF Oscillator, a divide by 32 prescaler and a phase detector which combine to form a PLL system. A signal from the OCXO is injected into Xtalb pin and multiplied by 32 to give the 406.028 MHz signal. Modulation can be put on the 406.028 MHz signal by injecting current into the feedback loop or Icont pin on the chip.

The PLL can be monitored just before each transmission to detect whether it has locked or not. Before each transmission the PLL-LOCK voltage is checked to see if the PLL is in a locked state. If the PLL goes out of lock the transmissions will not be sent.

- OCXO

The OCXO frequency is set to 12.688375 MHz which when multiplied by 32 gives you 406.028 MHz. The stability of the OCXO sets the stability of the whole system. The spec for the whole system is +/- .001 MHz. The spec for the OCXO is attached in the Annex A. A technical report on the long term frequency drift is in Annex B.

- MMBT5087

MMBT5087 is used for modulating the feed back loop of the system. The circuit works by injecting a current into the feedback loop. This extra current causes the PLL to be offset by the appropriate phase change of +/- 1.1 radians. The modulation is described in section (13).

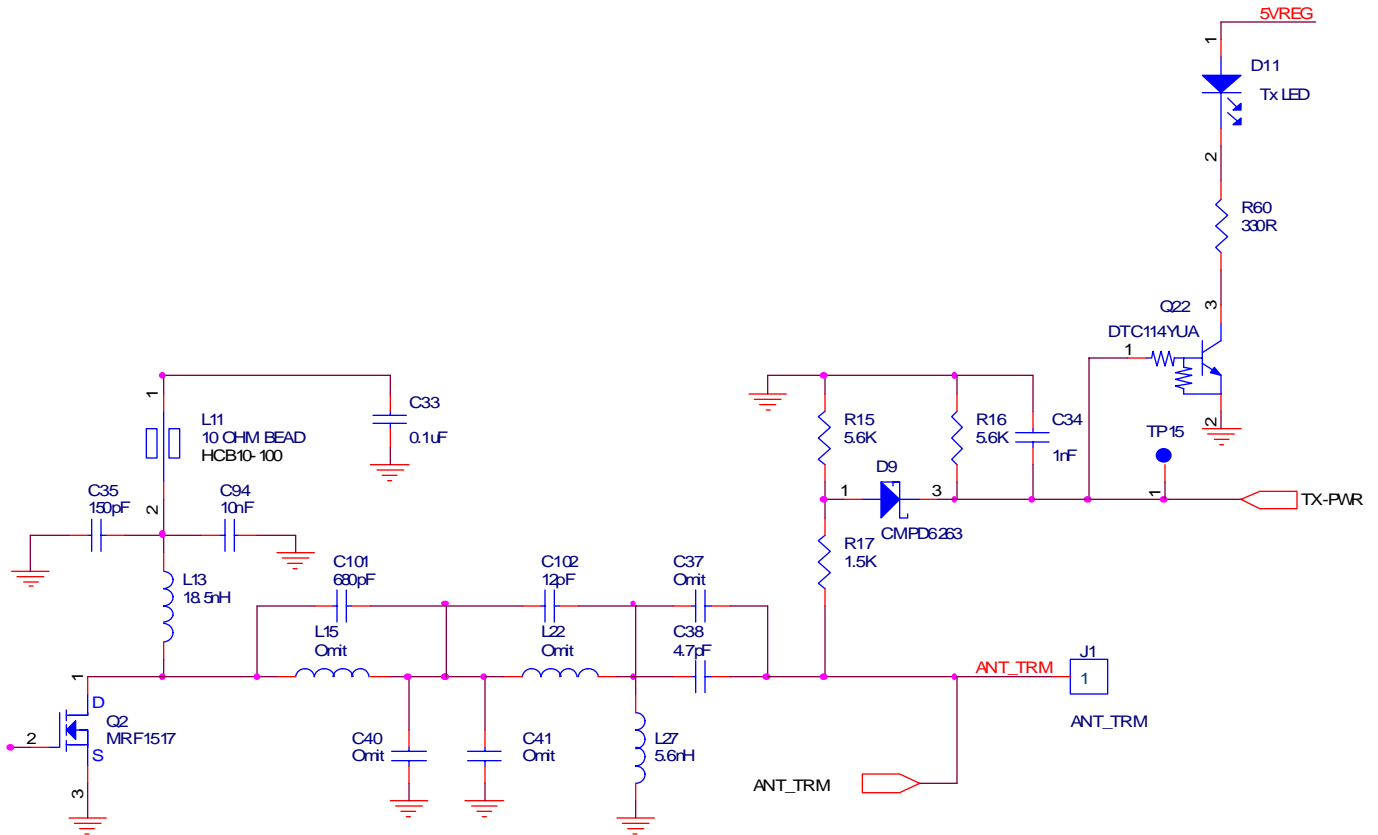

Figure 5. Filter and Power Measurement Circuitry

filter/matching network consists of C101, C102, L27, and C38. The filter reduces the spurs and harmonics produced by the power amplifier. The response for the filter is in Figure 6.

The power out is measured by monitoring the voltage at TX-PWR. There are no clamps or clipping circuits to restrict the power out. The power is limited by the regulated supply voltage. It is possible to measure both the 406 power and the 121 power this way. A self-test procedure has been implemented in the Pro-Find 406 to monitor the power out during a self-test. A failure is indicated if the power goes out of spec.

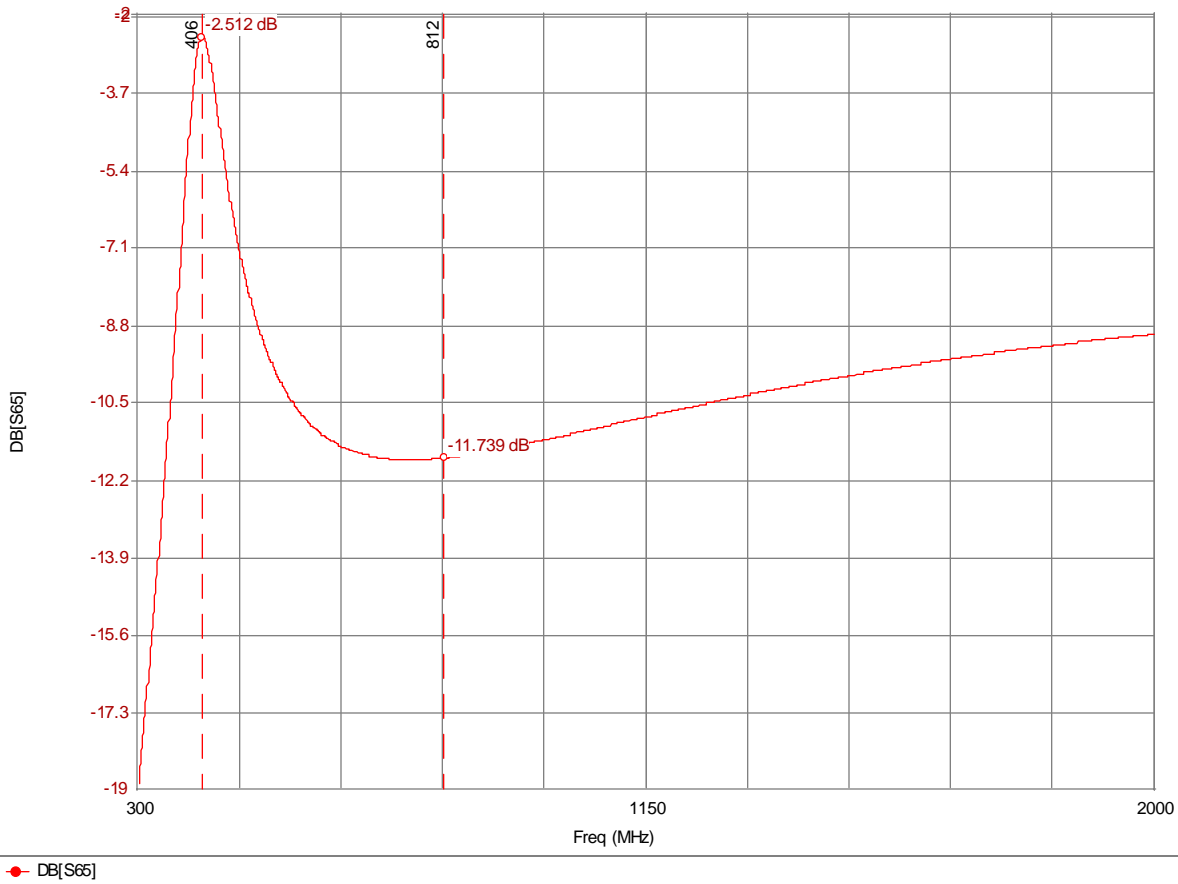

Figure 6. 406.028 MHz Filter/Matching Network Response

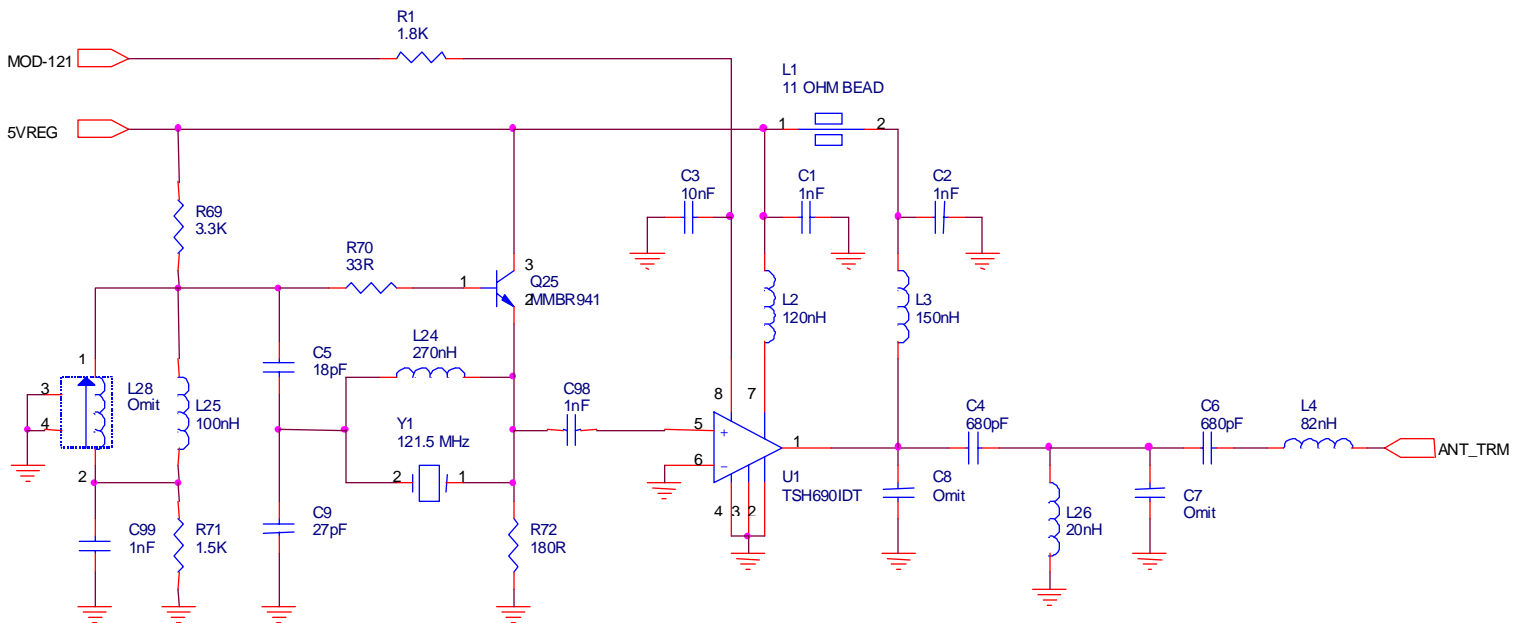

Figure 7. 121.5 MHz Oscillator and Amplifier Circuit

ii) The 121.5 MHz signal is created by the Oscillator and amplifier in Figure 7. The oscillator is a Butler Overtone Crystal Oscillator. The crystal itself determines the frequency and provides the stability of +/- .003 MHz. This signal is then fed into the TSH 690IDT amplifier. The TSH690IDT adds the modulation on to the 121.5 signal. This is accomplished by the MOD-121 line which biases the TSH 690IDT on and off. Once the signal is amplified it goes through a filter consisting of C4, L26, C6, and L4. The filter is a band pass filter and reduces any spurs or harmonics to meet specifications. The response for this filter is in Figure 8

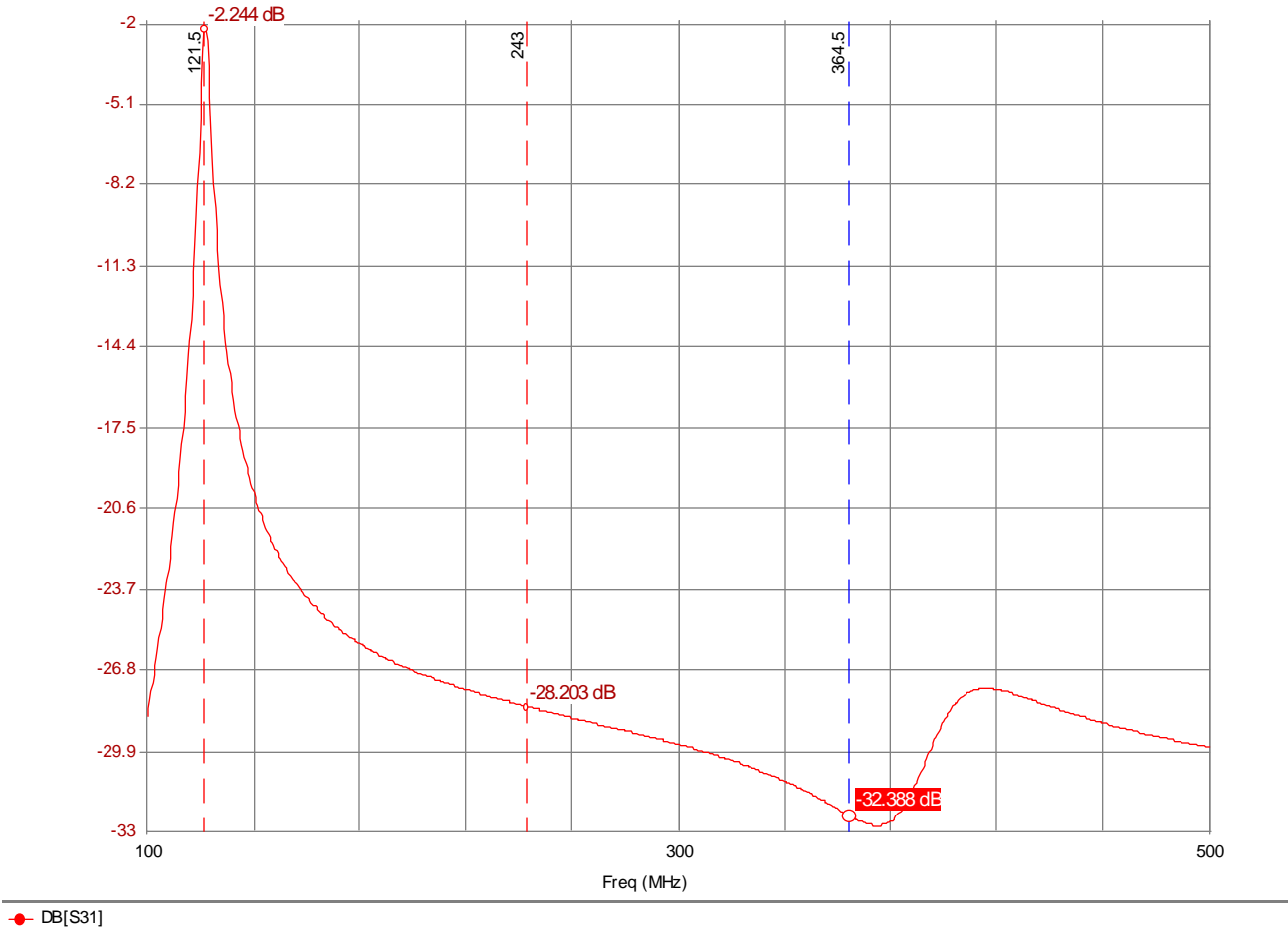
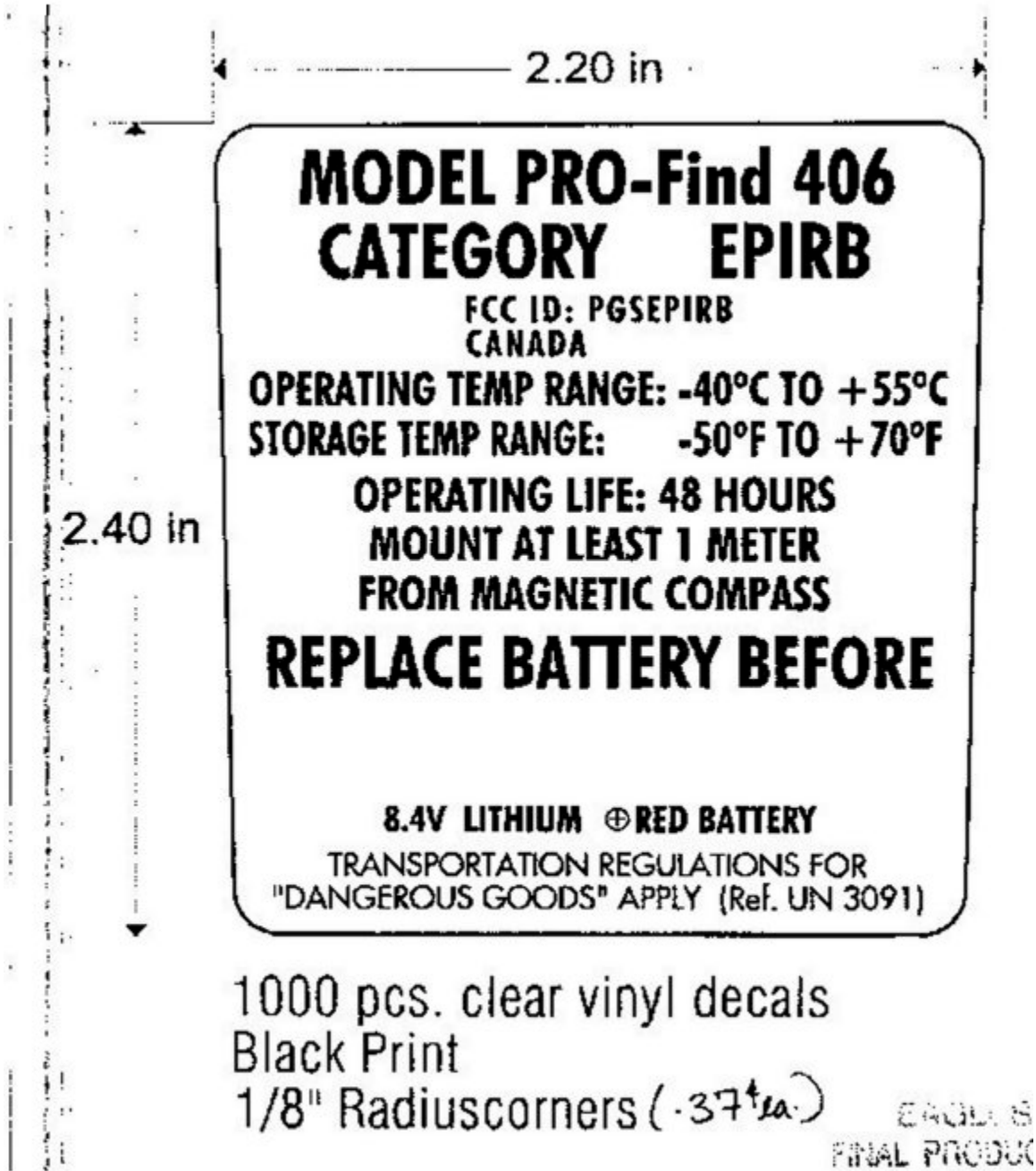

Figure 8. Response for 121.5 MHz Filter

(11) Photographs of Equipment Identification



1000 pcs. clear vinyl decals
Black Print
1/8" Radius corners (.375 in.)

EAQDLS
FINAL PRODUCT

Label 1

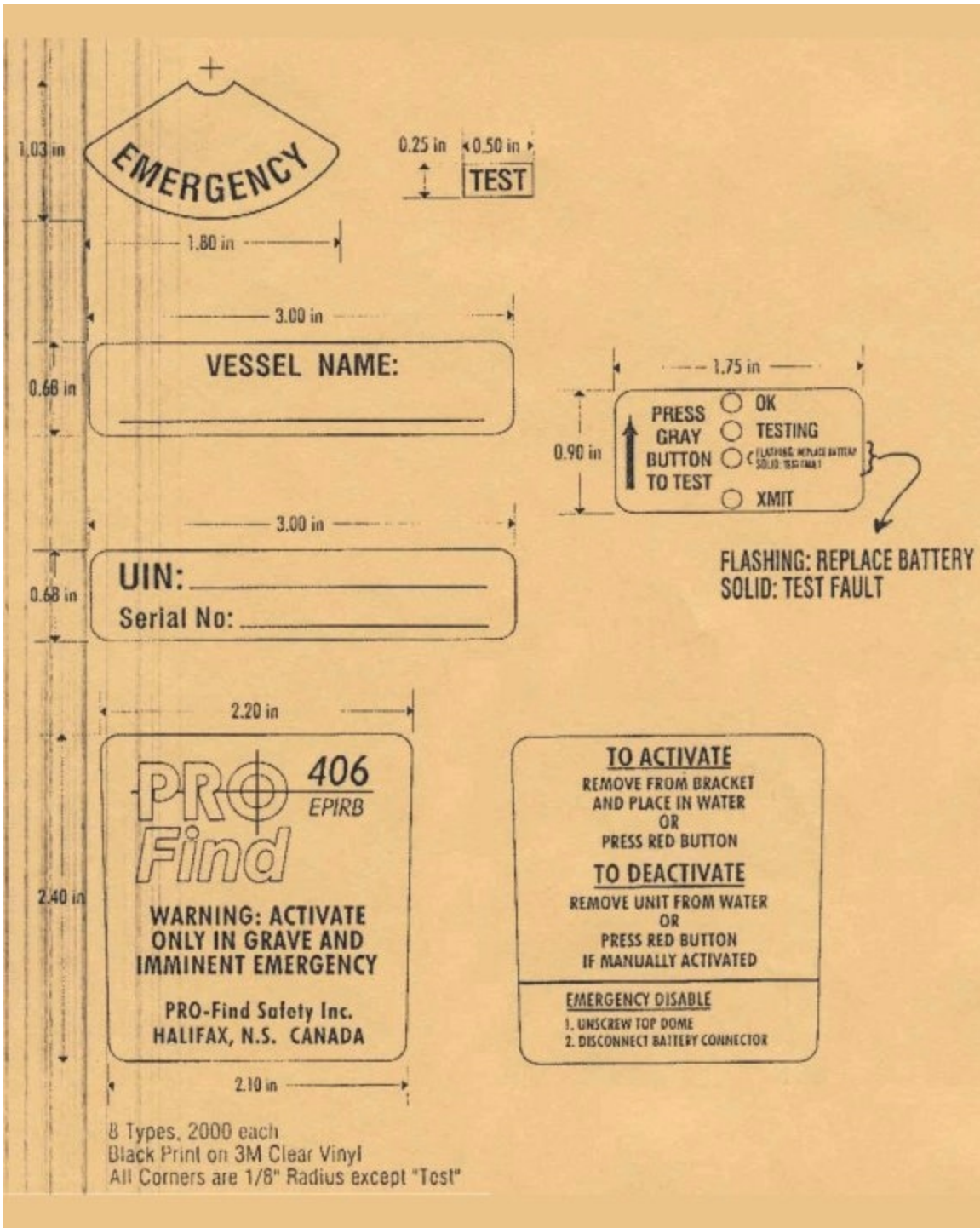

Label 2



Label 3

(12) Photographs of Equipment



Photograph 1. Close up of EPIRB



Photograph 2. Full EPIRB



Photograph 3. Emergency and Test Buttons on EPIRB



Photograph 4. EPIRB and Battery

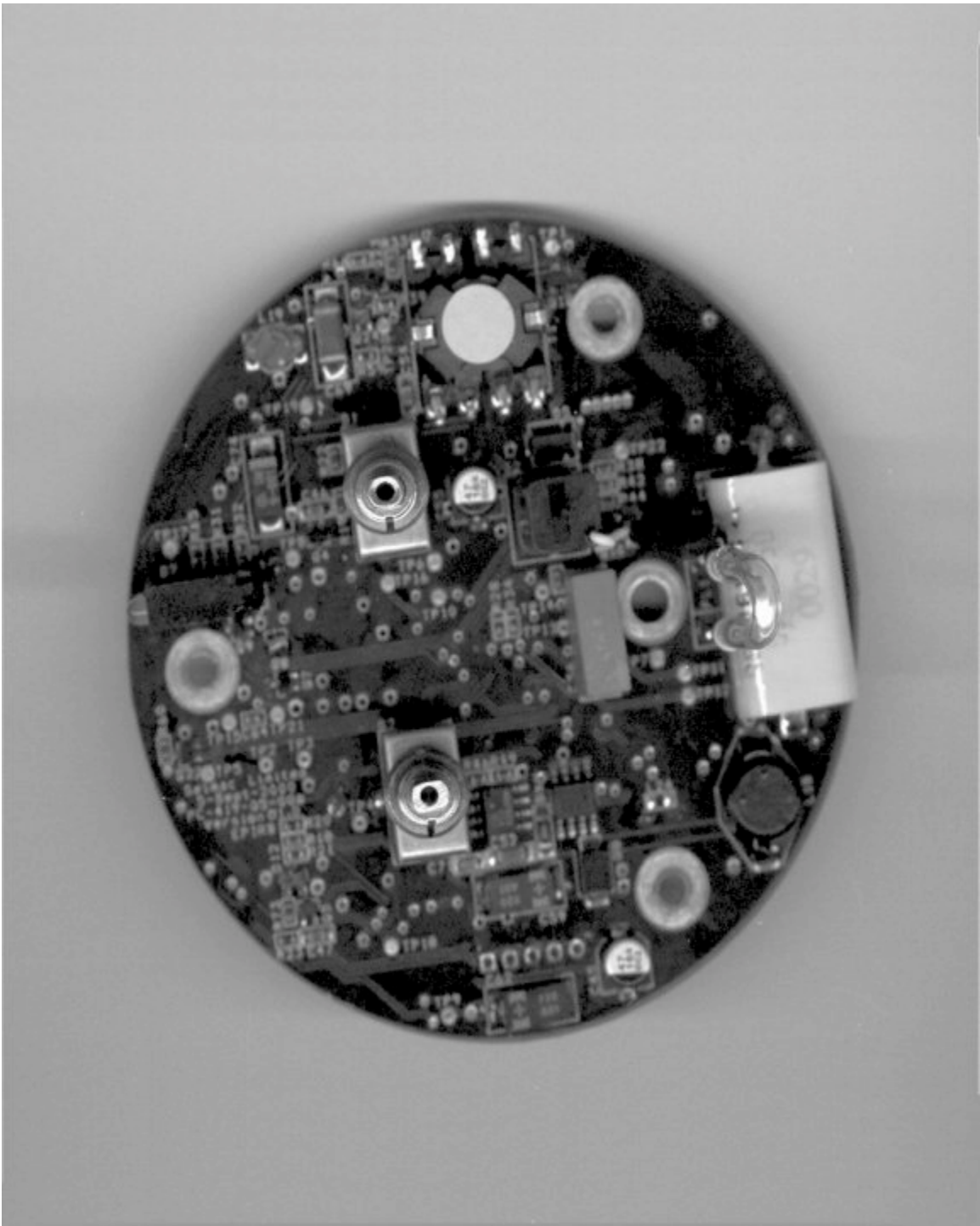

Photograph 5. Top of Circuit Board

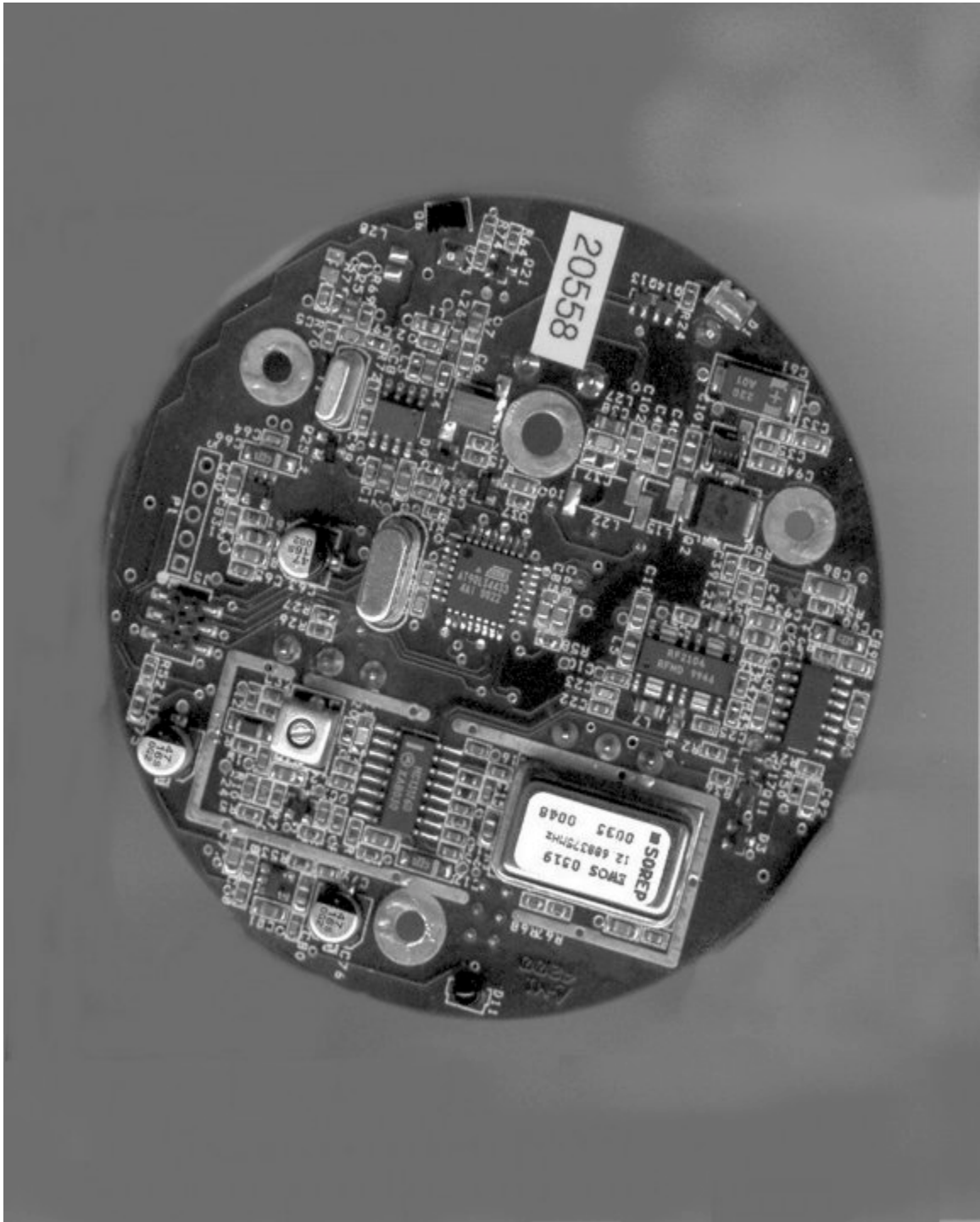

Photograph 6. Bottom of Circuit Board

(13) Digital Modulation

Digital Modulation is applied to the 406.028 MHz signal. The 121.5 MHz signal is not digitally modulated.

The 406.028 MHz carrier was phase modulated $\pm 1.1 + 0.1$ radians, referenced to an unmodulated carrier. The positive phase shift was a phase advance relative to nominal phase. The rise and fall times of the modulated waveform are less than $150 + 100$ ps. The digital message is Manchester encoded. The message wavetrain is detailed in 2.2.4.4 of the Specification for COSPAS-SARSAT 406 MHz Distress Beacon C/S T.001 Issue 3 – Revision 3 October 1993. Please refer to this specification for details. Please refer to *Type Approval Certification Test Report for the Seimac, Ltd. Cospas-Sarsat Beacon*, dated November 2000 for details of the response characteristics of the modulation. The modulating circuit is shown Figure 9.

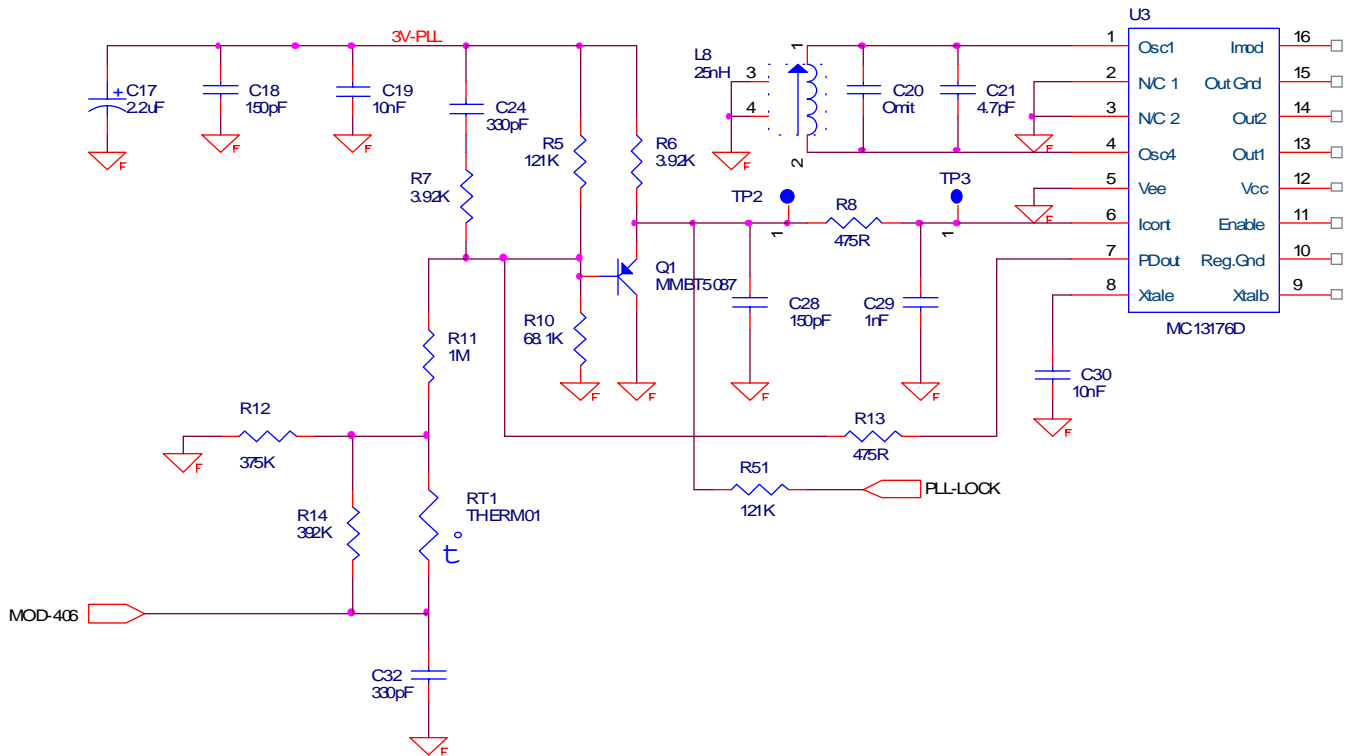

Figure 9. Digital Modulation Circuitry for the 406.028 MHz Signal

The modulation is applied to the 406.028 MHz signal by injecting a current into the feedback of the PLL (MC13176D). This current can be adjusted to apply the correct phase change required for the digital modulation. The MOD-406 line initiates the modulation. This line can be 1 of 3 different voltage levels that limit the modulation to 3 different phase angles. The lowest level gives -1.1 radians, the middle level gives 0 radians and the highest level gives $+1.1$ radians. The 3 levels go through a voltage divider that

includes RT1 for temperature compensation. C32 shapes the rise and fall time of the voltages to meet spurious specifications. This voltage is then applied to the base of Q1 which causes a current to be injected into the feedback loop through R8. This extra current causes the phase change.

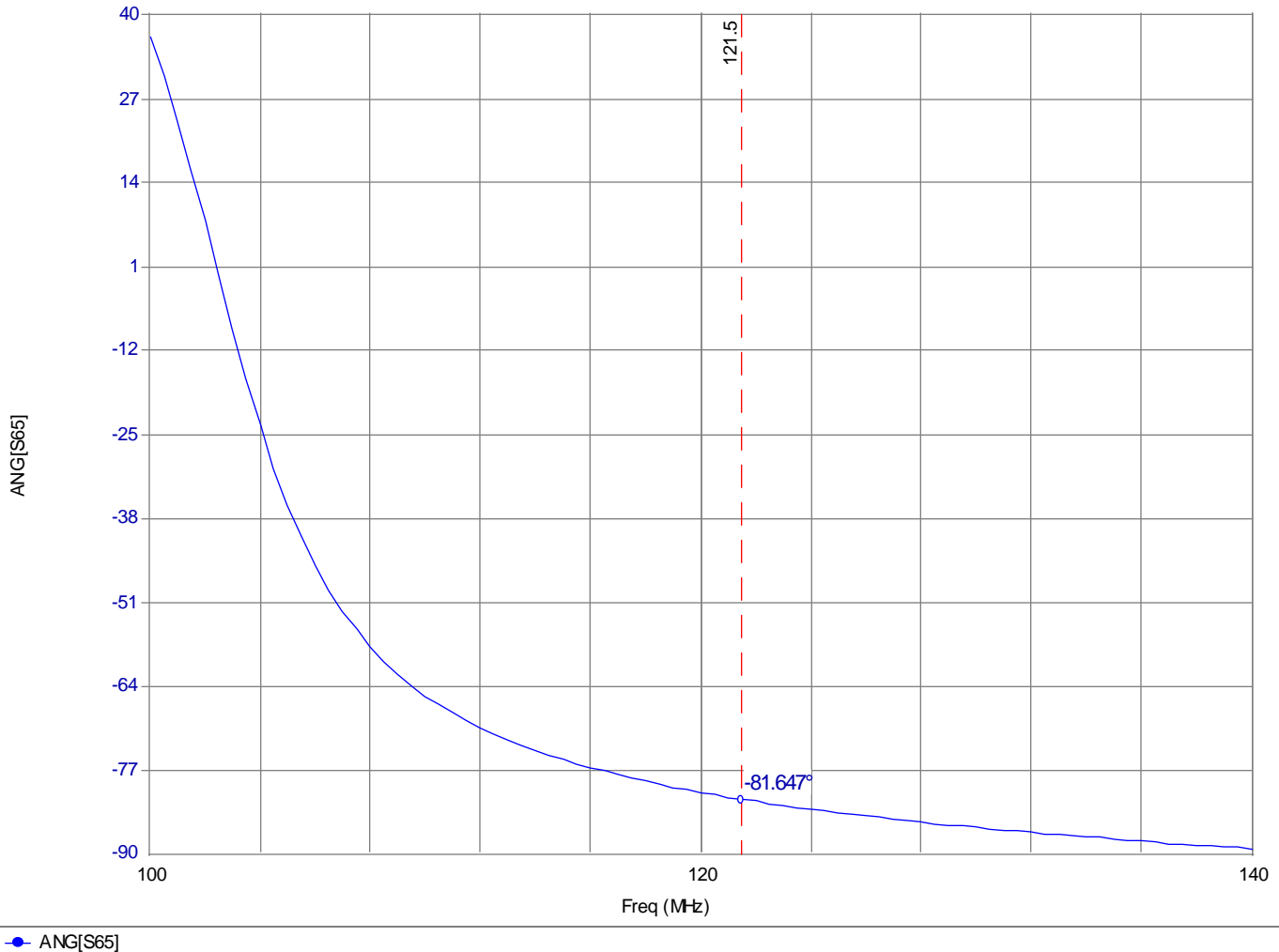

Figure 10. Phase Response of 406.028 MHz Filter

Once the modulation has been applied to the 406.028 MHz signal it is amplified. At the output of the Power Amplifier is a filter as shown in Figure 5. The filters response is shown in Figure 6 and Figure 10.

(14) Data Required by 2.1046 through 2.1057

Tests specified by 2.1046 through 2.1057 are completed in reports

RTCM Type Approval Certification Test Report for the Seimac, Ltd. Cospas-Sarsat Beacon, dated December 2000. See file “RTCM Certification.pdf”

Type Approval Certification Test Report for the Seimac, Ltd. Cospas-Sarsat Beacon, dated November 2000. See file “C-S Certification.pdf”

(15) Certification under Part 97

Part 97 does not apply.

(16) Certification of AM broadcast

Does not apply.

(17) Application for Composite System

Does not apply

Annex A

Sorep Data Sheet

ELECTRICAL
CHARACTERISTI

PARAMETER	Unit	Min.	Typ.	Max.	Note	Comments
OUTPUT FREQUENCY	MHz	12.688375			1	Nominal frequency
FREQUENCY TOLERANCE	ppm		± 2		1	25°C
TEMPERATURE RANGE						
Operating	°C	-40		+55	1	
Storage	°C	-55		+75	4	
SUPPLY VOLTAGE	V	5 ± 5 %				
SUPPLY CURRENT						
warm-up	mA			250	3	
Steady state / +25°C	mA		20	25	3	
Steady state / -40°C	mA		50	55	3	
Steady state / +55°C	mA		10	12	3	
WARM-UP TIME	s			60	3	
FREQUENCY STABILITY						
Vs temperature variation	ppm		±0.2	±0.5	1	5 V ± 5 % Allan variance / 100 ms
Vs supply voltage variation	ppm		±0.1	±0.2	3	
Short time			1.10 ⁻¹⁰		3	
Medium term : - slope				±1.10 ⁻⁹	1	
- sigma				3.10 ⁻⁹	1	
Aging						Over full temperature range
per day			±2.10 ⁻⁹		4	
per year	ppm			±0.5	4	
PHASE NOISE	dBc/Hz		-110		4	100 Hz offset
OUTPUT LEVEL	Vpp	1.2	1.5	2	3	Clipped sinewave - DC cut Load 10KΩ/10pF

Notes :

- 1 . Parameter inspected at 100 %.
- 2 . Parameter inspected by sampling.
- 3 . Parameter guaranteed by design and characterization.
- 4 . Parameter guaranteed by periodical qualification.

C			
---	--	--	--

B					
A					
INDICE	DATE	AUTEUR	MODIFICATIONS		
Rip :	Date :	Visa :	Qualité :	Date :	Visa :
			FICHE TECHNIQUE		
			EW OS 0519		
			FT004N790		Page 1/2

This document is SOREP ERULEC property and cannot be duplicated without its approval

PACKAGE OUTLINE

Packing unit : 100 pieces in tray.

Marking :

SOREP
EW OS 05
12.688375 M
Date cod
Serial numl
Location of l

Bottom view

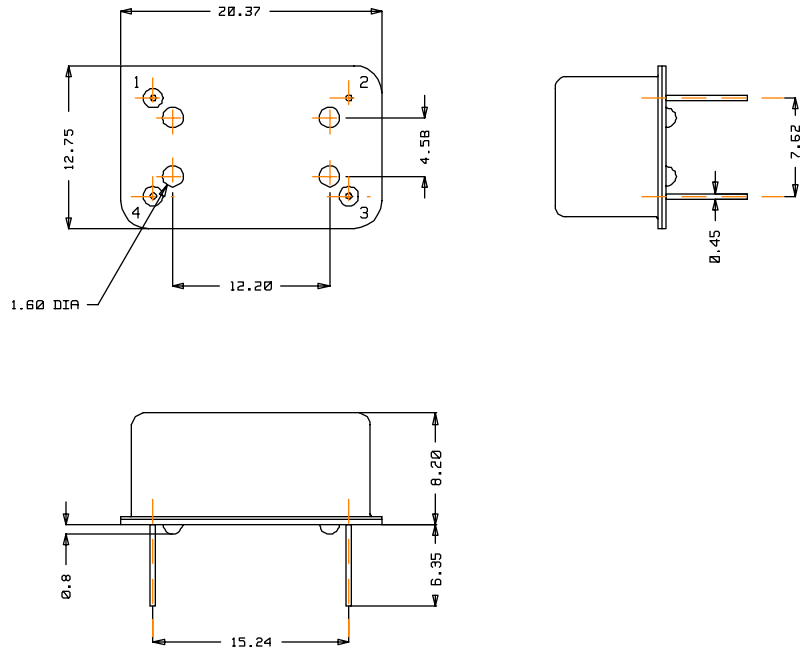

Pin nb	Function
1	N.C.
2	GROUND
3	RF OUT
4	POWER SUPPLY

RELIABILITY TEST

ITEM	TEST	REFERENCE
Shocks	Each axe	IEC 68-2-27
Vibration	Each axe	IEC 68-2-6
Brasability	IR furnace	IEC 68-2-20
Resistance to solvents		IEC 68-2-45
Temperature cycling	25 cycles	IEC 68-2-14

Climatic sequence		IEC 68-1 art 7
Humidity resistance	56 days	IEC 68-2-3
Life test	1000 hours	—
Warm storage aging	1000 hours	—

Nota : If some tests already been made on similar products (on which this OCXO can be associated), they will not be made another time.

C					
B					
A					
INDICE	DATE	AUTEUR	MODIFICATIONS		
Rip :	Date :	Visa :	Qualité :	Date :	Visa :
			FICHE TECHNIQUE		
			EW OS 0519		
			FT004N790	Page 2/2	

This document is SOREP ERULEC property and cannot be duplicated without its approval

SOREP ERULEC reserves the right to make changes to the products described in this catalog to improve performance, reliability of manufacturability at any time without notice. Changes and additions made after the publication of this catalog will be reflected in updated product data sheets or other literature as soon as possible.

SOREP ERULEC. SOCIETE ANONYME AU CAPITAL DE 17 640 200 FF REGIE PAR LES ARTICLES 118 A 150 DE LA LOI DU 24 JUILLET 1966. DOM. BANC. BANQUE NATIONALE DE PARIS - SIR. 313 384 695 00018 - R.C. RENNES B 313 384 695 - CODE APE 321 B.

Siège social et usine / Headquarters and factory :
Z.I. de Bellevue - B.P. 5 - 35221 CHATEAUBOURG CEDEX -
Tél. : +33.2.99.00.94.70 - Fax : +33.2.99.00.94.58

Annex B

Technical Report – TR-419-99-014 V1.0 Dec 2, 2000 Long Term Frequency stability Calculation

This document calculates the long term frequency drift for the ProFind 406 EPIRB.

1. Reference Oscillator Specifications

The ProFind 406 uses a phase-lock-loop (PLL) with a divide-by-32 circuit to generate a transmit frequency which is 32 times the reference frequency. The reference oscillator is a SOREP EWOS 0519 oven controlled oscillator with a nominal frequency of 12.688375 MHz. The PLL transmit circuit therefore generates a transmit frequency of $32 * 12.688375 \text{ MHz} = 406.028 \text{ MHz}$.

Since the transmitter is phase-locked to the reference oscillator, all of the long term frequency calculations may be based on the reference oscillator specifications.

The manufacturer's principal specifications for the EWOS 0519 are summarized below:

Parameter	Units	Min.	Typ.	Max.	Comments
Output Frequency	MHz		12.688375		Nominal freq.
Frequency Tolerance	ppm		±2		25°C
Temperature Range					
Operating	°C	-40		+55	
Storage	°C	-55		+75	
Supply Voltage	V		5 ± 5%		
Frequency Stability					
Short term			1.10e-10		AV / 100 ms
Medium term: -slope - sigma				±1.10e-9 3.1e-9	
Aging: per day per year	ppm		±2.10e-9	±0.5	Over full temp
Phase Noise	dBc/Hz		-110		100 Hz offset
Output Level	Vpp	1.2	1.5	2	10k/10pF load

2. Long Term Stability Calculations

The calculations for the ProFind 406 are as follows:

$$\begin{aligned}\text{Initial Frequency Offset} &= 2 \text{ PPM} \\ &= 2 * 10e-6 * 406.028 \text{ MHz} = 812 \text{ Hz}\end{aligned}$$

$$\text{Aging per Year} = 0.5 \text{ PPM}$$

$$\begin{aligned}\text{Aging Over 5 Years} &= 5 * 0.5 \text{ PPM} \\ &= 5 * 0.5 * 10e-6 * 406.028 \text{ MHz} = 1015 \text{ Hz}\end{aligned}$$

$$\text{Initial Offset + Aging (5 yrs)} = 812 \text{ Hz} + 1015 \text{ Hz} = 1827 \text{ Hz}$$

3. Conclusion

The allowable drift over 5 years (from C/S T001 Issue 3, Rev 2) is +2 kHz/-5 kHz. The ProFind 406 therefore meets the required specification for long term stability.

Annex C

User Manual

“File: Annex_C”