

EMC Test Report

Application for Grant of Equipment Authorization Class II Permissive Change/Reassessment

*FCC Part 15 Subpart C
FCC Part 15, Subpart E*

Model: HR44

FCC ID: PGRHR44

APPLICANT: Pace Americas, Inc.
310 Providence Mine Road, Suite 200
Nevada City, CA 95959

TEST SITE(S): National Technical Systems - Silicon Valley
41039 Boyce Road.
Fremont, CA. 94538-2435

IC SITE REGISTRATION #: 2845B-4

REPORT DATE: April 24, 2014

FINAL TEST DATES: April 7, 2014

TOTAL NUMBER OF PAGES: 26

PROGRAM MGR /
TECHNICAL REVIEWER:

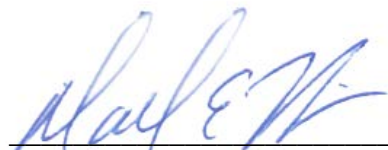

Mark E Hill
Staff Engineer

QUALITY ASSURANCE DELEGATE /
FINAL REPORT PREPARER:



David Guidotti
Senior Technical Writer



National Technical Systems - Silicon Valley is accredited by the A2LA, certificate number 0214.26, to perform the test(s) listed in this report, except where noted otherwise. This report and the information contained herein represent the results of testing test articles identified and selected by the client performed to specifications and/or procedures selected by the client. National Technical Systems (NTS) makes no representations, expressed or implied, that such testing is adequate (or inadequate) to demonstrate efficiency, performance, reliability, or any other characteristic of the articles being tested, or similar products. This report should not be relied upon as an endorsement or certification by NTS of the equipment tested, nor does it represent any statement whatsoever as to its merchantability or fitness of the test article, or similar products, for a particular purpose. This report shall not be reproduced except in full

REVISION HISTORY

Rev#	Date	Comments	Modified By
-	04-24-2014	First release	

TABLE OF CONTENTS

REVISION HISTORY2

TABLE OF CONTENTS3

SCOPE.....4

OBJECTIVE5

STATEMENT OF COMPLIANCE.....6

DEVIATIONS FROM THE STANDARDS.....6

TEST RESULTS SUMMARY7

 DIGITAL TRANSMISSION SYSTEMS (2400 – 2483.5MHZ).....7

 DIGITAL TRANSMISSION SYSTEMS (5725 –5850 MHZ).....7

 UNII / LELAN DEVICES8

 GENERAL REQUIREMENTS APPLICABLE TO ALL BANDS.....9

 MEASUREMENT UNCERTAINTIES.....10

EQUIPMENT UNDER TEST (EUT) DETAILS.....11

 GENERAL.....11

 ANTENNA SYSTEM11

 ENCLOSURE.....11

 MODIFICATIONS.....11

 SUPPORT EQUIPMENT.....11

 EUT INTERFACE PORTS12

 EUT OPERATION.....12

TEST SITE.....13

 GENERAL INFORMATION.....13

 CONDUCTED EMISSIONS CONSIDERATIONS13

 RADIATED EMISSIONS CONSIDERATIONS13

MEASUREMENT INSTRUMENTATION14

 RECEIVER SYSTEM14

 INSTRUMENT CONTROL COMPUTER14

 LINE IMPEDANCE STABILIZATION NETWORK (LISN).....14

 FILTERS/ATTENUATORS15

 ANTENNAS.....15

 ANTENNA MAST AND EQUIPMENT TURNTABLE.....15

 INSTRUMENT CALIBRATION.....15

TEST PROCEDURES16

 EUT AND CABLE PLACEMENT16

 CONDUCTED EMISSIONS.....16

 RADIATED EMISSIONS17

 SPECIFICATION LIMITS AND SAMPLE CALCULATIONS.....19

 CONDUCTED EMISSIONS SPECIFICATION LIMITS: FCC 15.207; FCC 15.107(A), RSS GEN.....19

APPENDIX A TEST EQUIPMENT CALIBRATION DATA20

APPENDIX B TEST DATA21

END OF REPORT26

SCOPE

An electromagnetic emissions test has been performed on the Pace Americas, Inc. model HR44, pursuant to the following rules:

FCC Part 15 Subpart C
FCC Part 15, Subpart E requirements for UNII Devices

Conducted and radiated emissions data has been collected, reduced, and analyzed within this report in accordance with measurement guidelines set forth in the following reference standards and as outlined in National Technical Systems - Silicon Valley test procedures:

ANSI C63.10-2009
FCC DTS Measurement Guidance KDB558074
FCC General UNII Test Procedures KDB789033

The intentional radiator above has been tested in a simulated typical installation to demonstrate compliance with the relevant Industry Canada performance and procedural standards.

Final system data was gathered in a mode that tended to maximize emissions by varying orientation of EUT, orientation of power and I/O cabling, antenna search height, and antenna polarization.

Every practical effort was made to perform an impartial test using appropriate test equipment of known calibration. All pertinent factors have been applied to reach the determination of compliance.

Note, testing was limited to AC conducted emissions. The only change to the product was the external AC/DC adapter. Original testing showed no radio related emissions below 1GHz.

OBJECTIVE

The primary objective of the manufacturer is compliance with the regulations outlined in the previous section.

Prior to marketing in the USA, all unlicensed transmitters and transceivers require certification. Receive-only devices operating between 30 MHz and 960 MHz are subject to either certification or a manufacturer's declaration of conformity, with all other receive-only devices exempt from the technical requirements.

Certification is a procedure where the manufacturer submits test data and technical information to a certification body and receives a certificate or grant of equipment authorization upon successful completion of the certification body's review of the submitted documents. Once the equipment authorization has been obtained, the label indicating compliance must be attached to all identical units, which are subsequently manufactured.

Maintenance of compliance is the responsibility of the manufacturer. Any modification of the product which may result in increased emissions should be checked to ensure compliance has been maintained (i.e., printed circuit board layout changes, different line filter, different power supply, harnessing or I/O cable changes, etc.).

STATEMENT OF COMPLIANCE

The tested sample of Pace Americas, Inc. model HR44 complied with the requirements of the following regulations:

FCC Part 15 Subpart C
FCC Part 15, Subpart E requirements for UNII Devices

Maintenance of compliance is the responsibility of the manufacturer. Any modifications to the product should be assessed to determine their potential impact on the compliance status of the device with respect to the standards detailed in this test report.

The test results recorded herein are based on a single type test of Pace Americas, Inc. model HR44 and therefore apply only to the tested sample. The sample was selected and prepared by Mark Rieger of Pace Americas, Inc.

DEVIATIONS FROM THE STANDARDS

No deviations were made from the published requirements listed in the scope of this report.

TEST RESULTS SUMMARY**DIGITAL TRANSMISSION SYSTEMS (2400 – 2483.5MHz)**

FCC Rule Part	RSS Rule Part	Description	Measured Value / Comments	Limit / Requirement	Result
15.247(a)	RSS 210 A8.2	Digital Modulation	Testing not performed. Results unchanged from original filing.		
15.247 (a) (2)	RSS 210 A8.2 (1)	6dB Bandwidth			
15.247 (b) (3)	RSS 210 A8.2 (4)	Output Power (multipoint systems)			
15.247(d)	RSS 210 A8.2 (2)	Power Spectral Density			
15.247(c)	RSS 210 A8.5	Antenna Port Spurious Emissions 30MHz – 25 GHz			
15.247(c) / 15.209	RSS 210 A8.5	Radiated Spurious Emissions 30MHz – 25 GHz			

DIGITAL TRANSMISSION SYSTEMS (5725 –5850 MHz)

FCC Rule Part	RSS Rule Part	Description	Measured Value / Comments	Limit / Requirement	Result
15.247(a)	RSS 210 A8.2	Digital Modulation	Testing not performed. Results unchanged from original filing.		
15.247 (a) (2)	RSS 210 A8.2 (1)	6dB Bandwidth			
15.247 (b)	RSS 210 A8.2 (4)	Output Power (multipoint systems)			
15.247(d)	RSS 210 A8.2 (2)	Power Spectral Density			
15.247(c)	RSS 210 A8.5	Antenna Port Spurious Emissions – 30MHz – 40 GHz			
15.247(c) / 15.209	RSS 210 A8.5 Table 2, 3	Radiated Spurious Emissions 30MHz – 40 GHz			

UNII / LELAN DEVICES**Operation in the 5.15 – 5.25 GHz Band**

FCC Rule Part	RSS Rule Part	Description	Measured Value / Comments	Limit / Requirement	Result
15.407(e)		Indoor operation only	Testing not performed. Results unchanged from original filing.		
15.407(a)(2)		26dB Bandwidth			
15.407(a)(1)	A9.2(1)	Output Power			
15.407(a)(1)	-	Power Spectral Density			
-	A9.5(2)				

Operation in the 5.25 – 5.35 GHz Band

FCC Rule Part	RSS Rule Part	Description	Measured Value / Comments	Limit / Requirement	Result (margin)
15.407(a)(2)		26dB Bandwidth	Testing not performed. Results unchanged from original filing.		
15.407(a)(2)	A9.2(2)	Output Power			
15.407(a)(2)	-	Power Spectral Density			
-	A9.2(2) / A9.5(2)	Power Spectral Density			

Operation in the 5.47 – 5.725 GHz Band

FCC Rule Part	RSS Rule Part	Description	Measured Value / Comments	Limit / Requirement	Result (margin)
15.407(a)(2)		26dB Bandwidth	Testing not performed. Results unchanged from original filing.		
15.407(a)(2)	A9.2(2)	Output Power			
15.407(a)(2)		Power Spectral Density			
	A9.2(2) / A9.5(2)	Power Spectral Density			
KDB 443999	A9	Non-operation in 5600 – 5650 MHz sub band			

Requirements for all U-NII/LELAN bands

FCC Rule Part	RSS Rule Part	Description	Measured Value / Comments	Limit / Requirement	Result
15.407	A9.5a	Modulation	Testing not performed. Results unchanged from original filing.		
15.407(b)(5) / 15.209	A9.3	Spurious Emissions			
15.407(a)(6)	-	Peak Excursion Ratio			
15	A9.5 (3)	Channel Selection			
15.407 (c)	A9.5(4)	Operation in the absence of information to transmit			
15.407 (g)	A9.5 (5)	Frequency Stability			
15.407 (h1)	A9.4	Transmit Power Control			
15.407 (h2)	A9.4	Dynamic frequency Selection (device without radar detection)			
	A9.9g	User Manual information			

GENERAL REQUIREMENTS APPLICABLE TO ALL BANDS

FCC Rule Part	RSS Rule part	Description	Measured Value / Comments	Limit / Requirement	Result (margin)
15.203	-	RF Connector	Testing not performed. Results unchanged from original filing.		
15.207	RSS GEN Table 2	AC Conducted Emissions Delta Power Supply	38.3 dB μ V @ 0.510 MHz (-7.7 dB)	Refer to page 19	Complies
15.109	RSS GEN 7.2.3 Table 1	Receiver spurious emissions	Testing not performed. Results unchanged from original filing.		
15.247 (b)(5) / 15.407 (f)	RSS 102	RF Exposure Requirements			
-	RSP 100 RSS GEN 7.1.5	User Manual			
-	RSP 100 RSS GEN 7.1.5	User Manual			
-	RSP 100 RSS GEN 4.4.1	99% Bandwidth			

MEASUREMENT UNCERTAINTIES

ISO/IEC 17025 requires that an estimate of the measurement uncertainties associated with the emissions test results be included in the report. The measurement uncertainties given below are based on a 95% confidence level and were calculated in accordance with UKAS document LAB 34.

Measurement Type	Measurement Unit	Frequency Range	Expanded Uncertainty
RF power, conducted (power meter)	dBm	25 to 7000 MHz	± 0.52 dB
RF power, conducted (Spectrum analyzer)	dBm	25 to 7000 MHz	± 0.7 dB
Conducted emission of transmitter	dBm	25 to 26500 MHz	± 0.7 dB
Conducted emission of receiver	dBm	25 to 26500 MHz	± 0.7 dB
Radiated emission (substitution method)	dBm	25 to 26500 MHz	± 2.5 dB
Radiated emission (field strength)	dB μ V/m	25 to 1000 MHz	± 3.6 dB
		1000 to 40000 MHz	± 6.0 dB
Conducted Emissions (AC Power)	dB μ V	0.15 to 30 MHz	± 2.4 dB

EQUIPMENT UNDER TEST (EUT) DETAILS**GENERAL**

The Pace Americas, Inc. model HR44 is a set-top-box that incorporates 802.11abgn 2x2 and 2.4GHz 802.15.4 radios. Since the EUT would be placed on a table top during operation, the EUT was treated as table-top equipment during testing to simulate the end-user environment. The electrical rating of the EUT is 120Volts, 60Hz, 1.3Amps.

The sample was received on April 7, 2014 and tested on April 7, 2014. The EUT consisted of the following component(s):

Company	Model	Description	Serial Number	FCC ID
Direct TV	HR44	Set-top-box	G33DB3DX001382	PGRHR44
Delta	EPS44R2-16	External power supply	DD4B1404A0032	N/A

ANTENNA SYSTEM

The wifi and 802.15.4 radios use separate antennas.

The peak gain for the WiFi antennas: 3.3 dBi (2.4GHz), 4.1 dBi (5GHz)

The peak gain for the 802.15.4 antennas: 4.9 dBi (2.4GHz)

ENCLOSURE

The EUT enclosure is primarily constructed of plastic. It measures approximately 34 cm wide by 25 cm deep by 4.5 cm high.

MODIFICATIONS

No modifications were made to the EUT during the time the product was at NTS Silicon Valley.

SUPPORT EQUIPMENT

The following equipment was used as support equipment for testing:

Company	Model	Description	Serial Number	FCC ID
G RAID	-	Sata Drive	-	-
SanDisk	-	USB Drive	-	-
Thomson, Inc.	29267GE1-B	Telephone	70961920	-

The following equipment was used as remote support equipment for emissions testing:

Company	Model	Description	Serial Number	FCC ID
Dell	Latitude D630	Laptop	-	-
Dell	Latitude 131L	Laptop	-	-
Toshiba	24SL415U	TV	B46193T06429C1	-
Radyne	DM240 Digital Modular	Satellite Headed		
Direct TV	DCA28R0-18oCA	MoCA to Ethernet Bridge	GDD4A1213B7667	
Direct TV	SWM	8 channel	N816900 823 652	
Pace	5031NW	Access Point	34131N000036	

EUT INTERFACE PORTS

The I/O cabling configuration during testing was as follows:

Port	Connected To	Description	Cable(s)	
			Shielded or Unshielded	Length(m)
Serial	Laptop	Multewire	Shielded	5
DC power	External power supply	2 wire	Unshielded	2
AC power (ext supply)	AC Mains	3 wire	Unshielded	2
Component	TV	RCA	Shielded	10
Ethernet	Laptop	CAT5	Unshielded	10
RJ-11	Telephone	RJ-11	Unshielded	3
HDMI	TV	HDMI	Shielded	10
Composite	TV	RCA	Shielded	10
MoCA	Satellite	MoCA to Ethernet	Shielded	10
Sata	Sata Drive	Sata	Shielded	2
SPDIF	75ohm	RCA	Shielded	2.5

EUT OPERATION

The EUT (Satellite Set Top Box) was setup supporting a Direct TV video test stream from a Satellite Head-end simulator and in turn displaying it on a TV over the HDMI at 1080i, Component, and Composite outputs. A 75 ohm splitter was used between the head-end and the STB to split out the MoCA communications from the EUT to a DECA (MoCA to Ethernet bridge) and pinging the EUT (MOCA communications operating in the band 475MHz to 625MHz). The Ethernet port was connected to a separate PC and was also pinging the EUT. The USB port was terminated (and enumerated) into a USB Memory Stick. The eSATA port was terminated to a remote Hard drive (Note: The internal hard drive was active during this test since both cannot be active at one time). SPDIF was terminated into a 75 ohm load. The RJ11 telecom port was terminated into a 600 ohm load.

The RF4CE and WiFi radios were both enabled. The WiFi radio was associated with an access point.

TEST SITE**GENERAL INFORMATION**

Final test measurements were taken at the test sites listed below. Pursuant to section 2.948 of the FCC's Rules and section 3.3 of RSP-100, construction, calibration, and equipment data has been filed with the Commission and with industry Canada.

Site	Registration Numbers		Location
	FCC	Canada	
Chamber 4	A2LA accreditation	2845B-4	41039 Boyce Road Fremont, CA 94538-2435

ANSI C63.4 recommends that ambient noise at the test site be at least 6 dB below the allowable limits. Ambient levels are below this requirement. The test site(s) contain separate areas for radiated and conducted emissions testing. Considerable engineering effort has been expended to ensure that the facilities conform to all pertinent requirements of ANSI C63.4.

CONDUCTED EMISSIONS CONSIDERATIONS

Conducted emissions testing is performed in conformance with ANSI C63.10. Measurements are made with the EUT connected to the public power network through a nominal, standardized RF impedance, which is provided by a line impedance stabilization network, known as a LISN. A LISN is inserted in series with each current-carrying conductor in the EUT power cord.

RADIATED EMISSIONS CONSIDERATIONS

The FCC has determined that radiation measurements made in a shielded enclosure are not suitable for determining levels of radiated emissions. Radiated measurements are performed in an open field environment or in a semi-anechoic chamber. The test sites are maintained free of conductive objects within the CISPR defined elliptical area incorporated in ANSI C63.4 guidelines and meet the Normalized Site Attenuation (NSA) requirements of ANSI C63.4.

MEASUREMENT INSTRUMENTATION

RECEIVER SYSTEM

An EMI receiver as specified in CISPR 16-1-1 is used for emissions measurements. The receivers used can measure over the frequency range of 9 kHz up to 2000 MHz. These receivers allow both ease of measurement and high accuracy to be achieved. The receivers have Peak, Average, and CISPR (Quasi-peak) detectors built into their design so no external adapters are necessary. The receiver automatically sets the required bandwidth for the CISPR detector used during measurements. If the repetition frequency of the signal being measured is below 20Hz, peak measurements are made in lieu of Quasi-Peak measurements.

For measurements above the frequency range of the receivers, a spectrum analyzer is utilized because it provides visibility of the entire spectrum along with the precision and versatility required to support engineering analysis. Average measurements above 1000MHz are performed on the spectrum analyzer using the linear-average method with a resolution bandwidth of 1 MHz and a video bandwidth of 10 Hz, unless the signal is pulsed in which case the average (or video) bandwidth of the measuring instrument is reduced to onset of pulse desensitization and then increased.

INSTRUMENT CONTROL COMPUTER

The receivers utilize either a Rohde & Schwarz EZM Spectrum Monitor/Controller or contain an internal Spectrum Monitor/Controller to view and convert the receiver measurements to the field strength at an antenna or voltage developed at the LISN measurement port, which is then compared directly with the appropriate specification limit. This provides faster, more accurate readings by performing the conversions described under Sample Calculations within the Test Procedures section of this report. Results are printed in a graphic and/or tabular format, as appropriate. A personal computer is used to record all measurements made with the receivers.

The Spectrum Monitor provides a visual display of the signal being measured. In addition, the controller or a personal computer run automated data collection programs which control the receivers. This provides added accuracy since all site correction factors, such as cable loss and antenna factors are added automatically.

LINE IMPEDANCE STABILIZATION NETWORK (LISN)

Line conducted measurements utilize a fifty microhenry Line Impedance Stabilization Network as the monitoring point. The LISN used also contains a 250 uH CISPR adapter. This network provides for calibrated radio frequency noise measurements by the design of the internal low pass and high pass filters on the EUT and measurement ports, respectively.

FILTERS/ATTENUATORS

External filters and precision attenuators are often connected between the receiving antenna or LISN and the receiver. This eliminates saturation effects and non-linear operation due to high amplitude transient events.

ANTENNAS

A loop antenna is used below 30 MHz. For the measurement range 30 MHz to 1000 MHz either a combination of a biconical antenna and a log periodic or a bi-log antenna is used. Above 1000 MHz, horn antennas are used. The antenna calibration factors to convert the received voltage to an electric field strength are included with appropriate cable loss and amplifier gain factors to determine an overall site factor, which is then programmed into the test receivers or incorporated into the test software.

ANTENNA MAST AND EQUIPMENT TURNTABLE

The antennas used to measure the radiated electric field strength are mounted on a non-conductive antenna mast equipped with a motor-drive to vary the antenna height. Measurements below 30 MHz are made with the loop antenna at a fixed height of 1m above the ground plane.

ANSI C63.10 specifies that the test height above ground for table mounted devices shall be 80 centimeters. Floor mounted equipment shall be placed on the ground plane if the device is normally used on a conductive floor or separated from the ground plane by insulating material from 3 to 12 mm if the device is normally used on a non-conductive floor as specified in ANSI C63.4. During radiated measurements, the EUT is positioned on a motorized turntable in conformance with this requirement.

INSTRUMENT CALIBRATION

All test equipment is regularly checked to ensure that performance is maintained in accordance with the manufacturer's specifications. All antennas are calibrated at regular intervals with respect to tuned half-wave dipoles. An exhibit of this report contains the list of test equipment used and calibration information.

TEST PROCEDURES

EUT AND CABLE PLACEMENT

The regulations require that interconnecting cables be connected to the available ports of the unit and that the placement of the unit and the attached cables simulate the worst case orientation that can be expected from a typical installation, so far as practicable. To this end, the position of the unit and associated cabling is varied within the guidelines of ANSI C63.10, and the worst-case orientation is used for final measurements.

CONDUCTED EMISSIONS

Conducted emissions are measured at the plug end of the power cord supplied with the EUT. Excess power cord length is wrapped in a bundle between 30 and 40 centimeters in length near the center of the cord. Preliminary measurements are made to determine the highest amplitude emission relative to the specification limit for all the modes of operation. Placement of system components and varying of cable positions are performed in each mode. A final peak mode scan is then performed in the position and mode for which the highest emission was noted on all current carrying conductors of the power cord.

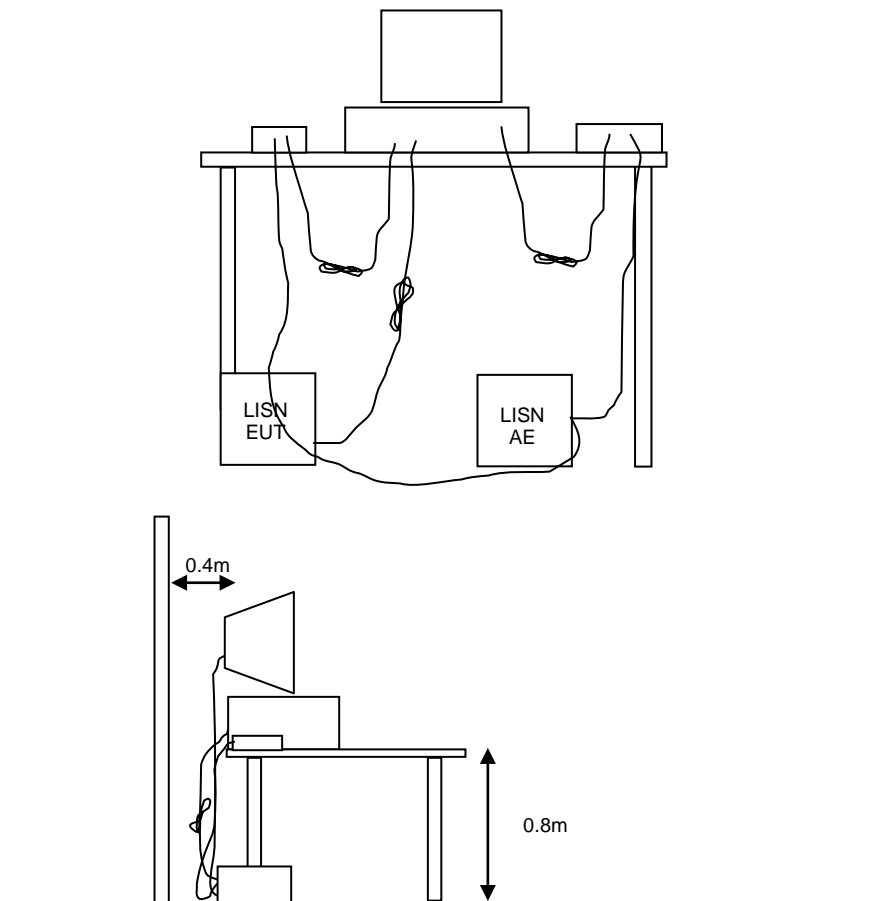

Figure 1 Typical Conducted Emissions Test Configuration

RADIATED EMISSIONS

A preliminary scan of the radiated emissions is performed in which all significant EUT frequencies are identified with the system in a nominal configuration. At least two scans are performed, one scan for each antenna polarization (horizontal and vertical; loop parallel and perpendicular to the EUT). During the preliminary scans, the EUT is rotated through 360°, the antenna height is varied (for measurements above 30 MHz) and cable positions are varied to determine the highest emission relative to the limit. Preliminary scans may be performed in a fully anechoic chamber for the purposes of identifying the frequencies of the highest emissions from the EUT.

A speaker is provided in the receiver to aid in discriminating between EUT and ambient emissions. Other methods used during the preliminary scan for EUT emissions involve scanning with near field magnetic loops, monitoring I/O cables with RF current clamps, and cycling power to the EUT.

Final maximization is a phase in which the highest amplitude emissions identified in the spectral search are viewed while the EUT azimuth angle is varied from 0 to 360 degrees relative to the receiving antenna. The azimuth, which results in the highest emission is then maintained while varying the antenna height from one to four meters (for measurements above 30 MHz, measurements below 30 MHz are made with the loop antenna at a fixed height of 1m). The result is the identification of the highest amplitude for each of the highest peaks. Each recorded level is corrected in the receiver using appropriate factors for cables, connectors, antennas, and preamplifier gain.

When testing above 18 GHz, the receive antenna is located at 1meter from the EUT and the antenna height is restricted to a maximum of 2.5 meters.

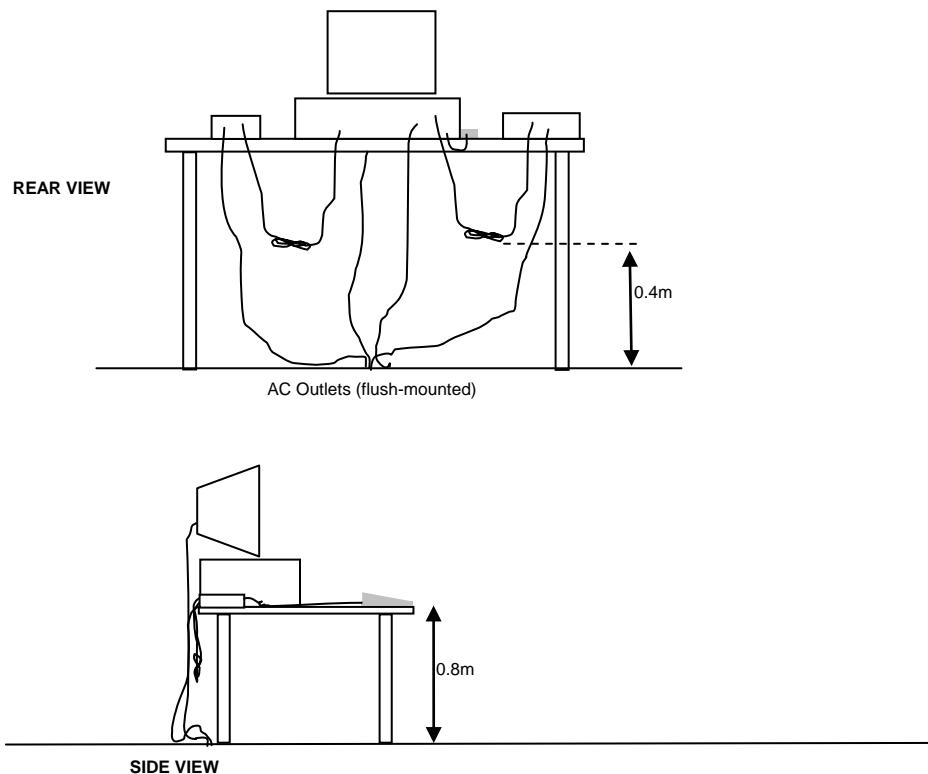

Typical Test Configuration for Radiated Field Strength Measurements

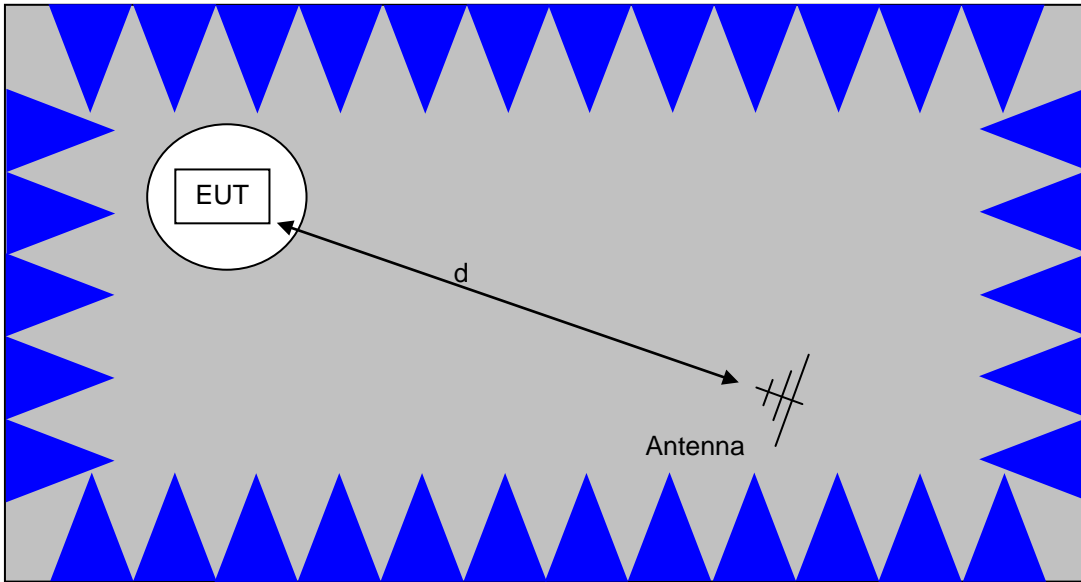

The anechoic materials on the walls and ceiling ensure compliance with the normalized site attenuation requirements of CISPR 16 / CISPR 22 / ANSI C63.4 for an alternate test site at the measurement distances used.

Floor-standing equipment is placed on the floor with insulating supports between the unit and the ground plane.

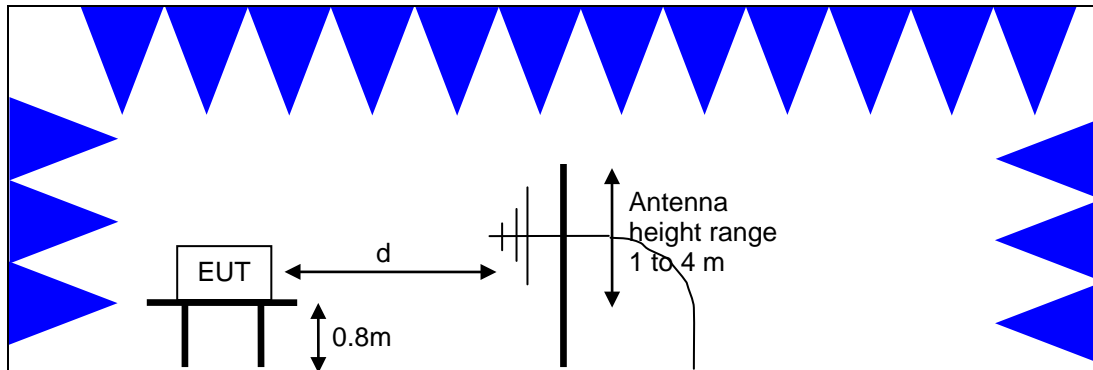

Test Configuration for Radiated Field Strength Measurements
Semi-Anechoic Chamber, Plan and Side Views

SPECIFICATION LIMITS AND SAMPLE CALCULATIONS

The limits for conducted emissions are given in units of microvolts, and the limits for radiated emissions are given in units of microvolts per meter at a specified test distance. Data is measured in the logarithmic form of decibels relative to one microvolt, or dB microvolts (dBuV). For radiated emissions, the measured data is converted to the field strength at the antenna in dB microvolts per meter (dBuV/m). The results are then converted to the linear forms of uV and uV/m for comparison to published specifications.

For reference, converting the specification limits from linear to decibel form is accomplished by taking the base ten logarithm, then multiplying by 20. These limits in both linear and logarithmic form are as follows:

CONDUCTED EMISSIONS SPECIFICATION LIMITS: FCC 15.207; FCC 15.107(a), RSS GEN

The table below shows the limits for the emissions on the AC power line from an intentional radiator and a receiver.

Frequency (MHz)	Average Limit (dBuV)	Quasi Peak Limit (dBuV)
0.150 to 0.500	Linear decrease on logarithmic frequency axis between 56.0 and 46.0	Linear decrease on logarithmic frequency axis between 66.0 and 56.0
0.500 to 5.000	46.0	56.0
5.000 to 30.000	50.0	60.0

Appendix A Test Equipment Calibration Data

Conducted Emissions - AC Power Ports, 07-Apr-14

<u>Manufacturer</u>	<u>Description</u>	<u>Model</u>	<u>Asset #</u>	<u>Cal Due</u>
EMCO	LISN, 10 kHz-100 MHz	3825/2	1293	2/13/2015
Rohde & Schwarz	Pulse Limiter	ESH3 Z2	1594	5/15/2014
Rohde & Schwarz	EMI Test Receiver, 20 Hz-7 GHz	ESIB7	1756	6/8/2014

Appendix B Test Data

T94950 Pages 22 - 25



EMC Test Data

Client:	Pace Americas, Inc.	Job Number:	J94865
Product:	HR44	T-Log Number:	T94950
Contact:	Mark Rieger	Project Manager:	Irene Rademacher
Emissions Standard(s):	FCC Part 15B	Project Coordinator:	-
Immunity Standard(s):	-	Class:	B
		Environment:	-

EMC Test Data

For The

Pace Americas, Inc.

Product

HR44

Date of Last Test: 4/7/2014



EMC Test Data

Client: Pace Americas, Inc.	Job Number: J94865
Model: HR44	T-Log Number: T94950
	Project Manager: Irene Rademacher
Contact: Mark Rieger	Project Coordinator: -
Standard: FCC Part 15B	Class: B

Conducted Emissions

(Elliott Laboratories Fremont Facility, Semi-Anechoic Chamber)

Test Specific Details

Objective: The objective of this test session is to perform final qualification testing of the EUT with respect to the specification listed above.

Date of Test: 4/7/2014	Config. Used: 1
Test Engineer: Jack Liu	Config Change: None
Test Location: Fremont Chamber #4	EUT Voltage: 120V/60Hz

General Test Configuration

For tabletop equipment, the EUT was located on a wooden table inside the semi-anechoic chamber, 40 cm from a vertical coupling plane and 80cm from the LISN. A second LISN was used for all local support equipment. Remote support equipment was located outside of the semi-anechoic chamber. Any cables running to remote support equipment were routed through metal conduit and when possible passed through a ferrite clamp upon exiting the chamber.

Ambient Conditions:	Temperature:	24 °C
	Rel. Humidity:	40 %

Summary of Results

Run #	Test Performed	Limit	Result	Margin
1	CE, AC Power, 120V/60Hz	Class B	Pass	38.3 dBµV @ 0.510 MHz (-7.7 dB)

Modifications Made During Testing

No modifications were made to the EUT during testing

Deviations From The Standard

No deviations were made from the requirements of the standard.



EMC Test Data

Client: Pace Americas, Inc.	Job Number: J94865
Model: HR44	T-Log Number: T94950
	Project Manager: Irene Rademacher
Contact: Mark Rieger	Project Coordinator: -
Standard: FCC Part 15B	Class: B

Run #1: AC Power Port Conducted Emissions, 0.15 - 30MHz, 120V/60Hz

Preliminary peak readings captured during pre-scan (peak readings vs. average limit)

Frequency MHz	Level dB μ V	AC Line	Class B		Detector QP/Ave	Comments
			Limit	Margin		
0.510	42.8	Neutral	46.0	-3.2	Peak	
13.464	46.1	Neutral	50.0	-3.9	Peak	
0.150	51.9	Neutral	56.0	-4.1	Peak	
0.155	50.7	Line	55.7	-5.0	Peak	
0.509	42.5	Line	46.0	-3.5	Peak	
13.506	45.4	Line	50.0	-4.6	Peak	

Final quasi-peak and average readings

Frequency MHz	Level dB μ V	AC Line	Class B		Detector QP/Ave	Comments
			Limit	Margin		
0.510	38.3	Neutral	46.0	-7.7	AVG	AVG (0.10s)
0.509	38.1	Line	46.0	-7.9	AVG	AVG (0.10s)
13.464	38.3	Neutral	50.0	-11.7	AVG	AVG (0.10s)
13.506	37.8	Line	50.0	-12.2	AVG	AVG (0.10s)
0.510	43.2	Neutral	56.0	-12.8	QP	QP (1.00s)
0.509	43.1	Line	56.0	-12.9	QP	QP (1.00s)
13.464	43.8	Neutral	60.0	-16.2	QP	QP (1.00s)
13.506	43.4	Line	60.0	-16.6	QP	QP (1.00s)
0.150	45.8	Neutral	66.0	-20.2	QP	QP (1.00s)
0.155	44.4	Line	65.7	-21.3	QP	QP (1.00s)
0.150	27.7	Neutral	56.0	-28.3	AVG	AVG (0.10s)
0.155	20.7	Line	55.7	-35.0	AVG	AVG (0.10s)

Client: Pace Americas, Inc.	Job Number: J94865
Model: HR44	T-Log Number: T94950
Contact: Mark Rieger	Project Manager: Irene Rademacher
Standard: FCC Part 15B	Project Coordinator: -
	Class: B

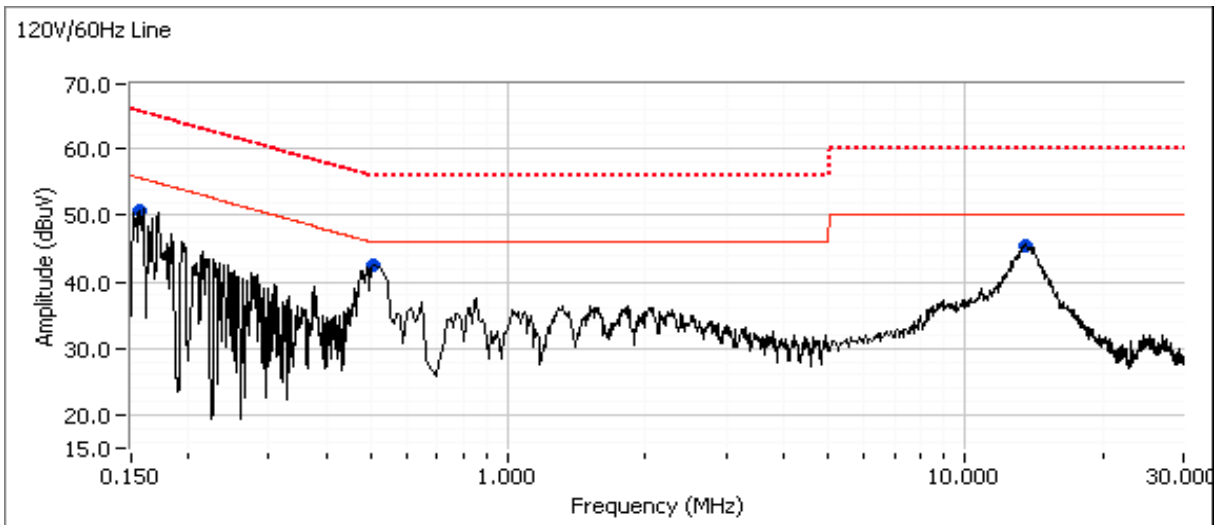
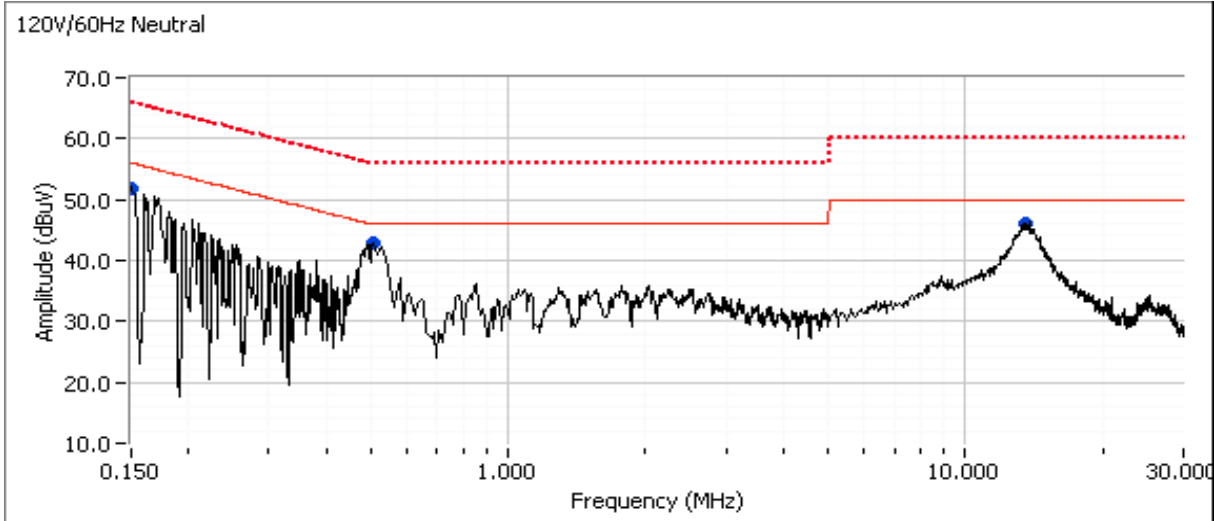

End of Report

This page is intentionally blank and marks the last page of this test report.