

Emissions Test Report

EUT Name: Wireless Video Access Point

Model No.: 405

CFR 47 Part 15.247 2012 and RSS 210:2010

Prepared for:

Mark Rieger
Pace Americas
310 Providence Mine Road, Ste. 200
Nevada City, CA 95959
Tel: (530) 274 5440
Fax: (530) 273 6340

Prepared by:

TUV Rheinland of North America, Inc.
1279 Quarry Lane
Pleasanton, CA 94566
Tel: (925) 249-9123
Fax: (925) 249-9124
<http://www.tuv.com/>

Report/Issue Date: May 9, 2013
Job Number 0000110737
Report Number: 31360999.002

Statement of Compliance

Manufacturer: Pace Americas
310 Providence Mine Road, Ste. 200
Nevada City, CA 95959
(530) 274 5440

Requester / Applicant: Mark Rieger

Name of Equipment: Wireless Video Access Point

Model No. 405

Type of Equipment: Intentional Radiator

Application of Regulations: CFR 47 Part 15.247 2012 and RSS 210:2010

Test Dates: 8 April 2013 to 3 May 2013

Guidance Documents:

Emissions: ANSI C63.10-2009, KDB 558074 D01 DTS Measurement Guidance v03r01

Test Methods:

Emissions: ANSI C63.10-2009, KDB 558074 D01 DTS Measurement Guidance v03r01

The electromagnetic compatibility test and documented data described in this report has been performed and recorded by TUV Rheinland, in accordance with the standards and procedures listed herein. As the responsible authorized agent of the EMC laboratory, I hereby declare that the equipment described above has been shown to be compliant with the EMC requirements of the stated regulations and standards based on these results. If any special accessories and/or modifications were required for compliance, they are listed in the Executive Summary of this report.

This report must not be used to claim product endorsement by A2LA or any agency of the U.S. Government. This report contains data that are not covered by A2LA accreditation. This report shall not be reproduced except in full, without the written authorization of TUV Rheinland of North America.



Jeremy Luong

Test Engineer

Date May 6, 2013

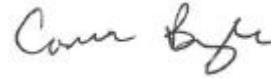

Jeremy Luong

Test Engineer

Date May 9, 2013



Testing Cert #3331.02



US5254



Industry
Canada Industrie
Canada

2932M-1

Table of Contents

1	Executive Summary	7
1.1	Scope	7
1.2	Purpose	7
1.3	Summary of Test Results	8
1.4	Special Accessories	8
1.5	Equipment Modifications	8
2	Laboratory Information	9
2.1	Accreditations & Endorsements	9
2.1.1	US Federal Communications Commission	9
2.1.2	NIST / A2LA	9
2.1.3	Canada – Industry Canada	9
2.1.4	Japan – VCCI	9
2.1.5	Acceptance by Mutual Recognition Arrangement	10
2.2	Test Facilities	10
2.2.1	Emission Test Facility	10
2.2.2	Immunity Test Facility	10
2.3	Measurement Uncertainty	10
2.3.1	Sample Calculation – radiated & conducted emissions	11
2.3.2	Measurement Uncertainty	11
2.3.3	Measurement Uncertainty Immunity	12
2.4	Calibration Traceability	12
3	Product Information	13
3.1	Product Description	13
3.2	Equipment Configuration	13
3.3	Operating Mode	13
3.4	Unique Antenna Connector	14
3.4.1	Results	14
4	Emissions	15
4.1	Output Power Requirements	15
4.1.1	Test Method	15
4.1.2	Results	16
4.2	Occupied Bandwidth	28
4.2.1	Test Method	28
4.2.2	Results	29
4.3	Unwanted Emissions into Non-Restricted Frequency Bands	51
4.3.1	Test Method	51
4.3.2	Results	52
4.4	Peak Power Spectral Density	86
4.4.1	Test Method	86
4.4.2	Results	86

Table of Contents

4.5	Transmitter Spurious Emissions	98
4.5.1	Test Methodology	98
4.5.2	Transmitter Spurious Emission Limit	99
4.5.3	Test Results	99
4.5.4	Sample Calculation	123
4.6	AC Conducted Emissions	124
4.6.1	Test Methodology	124
4.6.2	Test Results	124
4.7	Maximum Permissible Exposure	129
4.7.1	Test Methodology	129
4.7.2	RF Exposure Limit	129
4.7.3	EUT Operating Condition	130
4.7.4	Classification	130
4.7.5	Test Results	130
4.7.6	Sample Calculation	130
5	Test Equipment List	131
5.1	Equipment List	131
6	EMC Test Plan	132
6.1	Introduction	132
6.2	Customer	132
6.3	Equipment Under Test (EUT)	133
6.4	Test Specifications	138

Index of Tables

Table 1: Summary of Test Results.....	8
Table 2: RF Output Power at the Antenna Port – Test Results.....	16
Table 3: Average Output Power at the Antenna Port – Reference Only.....	17
Table 4: Occupied Bandwidth – Test Results.....	29
Table 5: Emissions at the Band-Edge – Test Results.....	52
Table 6: Peak Power Spectral Density – Test Results.....	87
Table 7: Transmit Spurious Emission at Band-Edge Requirements.....	100
Table 8: AC Conducted Emissions – Test Results.....	124
Table 9: Customer Information.....	132
Table 10: Technical Contact Information.....	132
Table 11: EUT Specifications.....	133
Table 12: EUT Channel Power Specifications.....	135
Table 13: Interface Specifications.....	135
Table 14: Supported Equipment.....	136
Table 15: Description of Sample used for Testing.....	136
Table 16: Description of Test Configuration used for Radiated Measurement.....	136
Table 17: Final Test Mode for 5725 - 5850 Bands.....	136
Table 18: Test Specifications.....	138

1 Executive Summary

1.1 Scope

This report is intended to document the status of conformance with the requirements of the CFR 47 Part 15.247 2012 and RSS 210:2010 based on the results of testing performed on 8 April 2013 to 3 May 2013 on the Wireless Video Access Point Model 405 manufactured by Pace Americas. This report only applies to the specific samples tested under the stated test conditions. It is the responsibility of the manufacturer to assure that additional production units of this model are manufactured with identical or EMI equivalent electrical and mechanical components. This report is further intended to document changes and modifications to the EUT throughout its life cycle. All documentation will be included as a supplement.

1.2 Purpose

Testing was performed to evaluate the EMC performance of the EUT in accordance with the applicable requirements, procedures, and criteria defined in the application of regulations and application of standards listed in this report. The 5725 MHz to 5850 MHz frequency band was covered in this document.

1.3 Summary of Test Results

Table 1: Summary of Test Results

Test	Test Method ANSI C63.4	Test Parameters (from Standard)	Result
Spurious Emission in Transmitted Mode	CFR47 15.209, RSS-GEN Sect.7.2.3	Class B	Complied
Restricted Bands of Operation	CFR47 15.205, RSS 210 Sect.2.6	Class B	Complied
AC Power Conducted Emission	CFR47 15.207, RSS-GEN Sect.7.2.2	Class B	Complied
Occupied Bandwidth	CFR47 15.247 (a2), RSS GEN Sect.4.4.1	≥ 500 kHz	Complied
Maximum Transmitted Power	CFR47 15.247 (b3), RSS 210 Sect. A.8.4	30 dBm	Complied
Peak Power Spectral Density	CFR47 15.247 (e), RSS 210 Sect. A.8.2	8 dBm/ 3 kHz.	Complied
Bandedge Measurement	CFR47 15.247 (d), RSS 210 Sect. A.8.5	20 dB	Complied
RF Exposure	CFR47 15.247 (i), 2.1091	General Population	Complied

Note: This report is only covered for 5725 to 5850 MHz.

1.4 Special Accessories

No special accessories were necessary in order to achieve compliance.

1.5 Equipment Modifications

None

2 Laboratory Information

2.1 Accreditations & Endorsements

2.1.1 US Federal Communications Commission



TUV Rheinland of North America at 1279 Quarry Ln, Pleasanton, CA 94566 is recognized by the commission for performing testing services for the general public on a fee basis. These laboratory test facilities have been fully described in reports submitted to and accepted by the FCC (US5254). The laboratory scope of accreditation includes: Title 47 CFR Parts 15, 18, and 90. The accreditation is updated every 3 years.

2.1.2 NIST / A2LA



TUV Rheinland of North America is accredited by the National Voluntary Laboratory Accreditation Program, which is administered under the auspices of the National Institute of Standards and Technology. The laboratory has been assessed and accredited in accordance with ISO Guide 17025:1999 and ISO 9002 (Lab Code Testing Cert #3331.02). The scope of laboratory accreditation includes emission and immunity testing. The accreditation is updated annually.

2.1.3 Canada – Industry Canada



TUV Rheinland of North America at the 1279 Quarry Ln, Pleasanton, CA 94566 address is accredited by Industry Canada for performing testing services for the general public on a fee basis. This laboratory test facilities have been fully described in reports submitted to and accepted by Industry Canada (File Number 2932M). This reference number is the indication to the Industry Canada Certification Officers that the site meets the requirements of RSS 212, Issue 1 (Provisional). The accreditation is updated every 3 years.

2.1.4 Japan – VCCI



The Voluntary Control Council for Interference by Information Technology Equipment (VCCI) is a group that consists of Information Technology Equipment (ITE) manufacturers and EMC test laboratories. The purpose of the Council is to take voluntary control measures against electromagnetic interference from Information Technology Equipment, and thereby contribute to the development of a socially beneficial and responsible state of affairs in the realm of Information Technology Equipment in Japan. TUV Rheinland of North America at 1279 Quarry Ln, Pleasanton, CA 94566 has been assessed and approved in accordance with the Regulations for Voluntary Control Measures.

VCCI Registration No. for Pleasanton: A-0031

VCCI Registration No. for Santa Clara: A-0032

2.1.5 Acceptance by Mutual Recognition Arrangement



The United States has an established agreement with specific countries under the Asia Pacific Laboratory Accreditation Corporation (APLAC) Mutual Recognition Arrangement. Under this agreement, all TUV Rheinland at 1279 Quarry Ln, Pleasanton, CA 94566 test results and test reports within the scope of the laboratory NIST / A2LA accreditation will be accepted by each member country.

2.2 Test Facilities

All of the test facilities are located at 1279 Quarry Lane, Pleasanton, California 94566, USA. The 2305 Mission College, Santa Clara, 95054, USA location is considered a Pleasanton annex.

2.2.1 Emission Test Facility

The Semi-Anechoic chamber and AC Line Conducted measurement facility used to collect the radiated and conducted data has been constructed in accordance with ANSI C63.7:1992. The site has been measured in accordance with and verified to comply with the theoretical normalized site attenuation requirements of ANSI C63.4-2009, at a test distance of 3 and 5 meters. The site is listed with the FCC and accredited by A2LA (Lab Code Testing Cert #3331.02). The 3/5-meter semi-anechoic chamber used to collect the radiated data has been verified to comply with the theoretical normalized site attenuation requirements of ANSI C63.4-2009, at a test distance of 3 meter and 5 meters. A report detailing this site can be obtained from TUV Rheinland of North America.

2.2.2 Immunity Test Facility

ESD, EFT, Surge, PQF: These tests are performed in an environmentally controlled room with a 3.7 m x 4.8 m x 3.175 mm thick aluminum floor connected to PE ground.

For ESD testing, tabletop equipment is placed on an insulated mat with a surface resistivity of 10^9 Ohms/square on a 1.6 m x 0.8 m x 0.8 m high non-conductive table with a 3.175 mm aluminum top (Horizontal Coupling Plane). The HCP is connected to the main ground plane via a low impedance ground strap through two 470-k Ω resistors. The Vertical Coupling Plane consists of an aluminum plate 50 cm x 50 cm x 3.175 mm thick. The VCP is connected to the main ground plane via a low impedance ground strap through two 470-k Ω resistors.

For EFT, Surge, PQF, the HCP and VCP are removed.

RF Field Immunity testing is performed in a 7.3m x 4.3m x 4.1m anechoic chamber.

RF Conducted and Magnetic Field Immunity testing is performed on a 4.8m x 3.7m x 3.175mm thick aluminum ground plane.

All test areas allow a minimum distance of 1 meter from the EUT to walls or conducting objects.

2.3 Measurement Uncertainty

Two types of measurement uncertainty are expressed in this report, per *ISO Guide To The Expression Of Uncertainty In Measurement*, 1st Edition, 1995.

The *Combined Standard Uncertainty* is the standard uncertainty of the result of a measurement when that result is obtained from the values of a number of other quantities; it is equal to the positive square root of the sum of the variances or co-variances of these other quantities, weighted according to how the measurement result varies with changes in these quantities. The term *standard uncertainty* is the result of a measurement expressed as a standard deviation.

2.3.1 Sample Calculation – radiated & conducted emissions

The field strength is calculated by subtracting the Amplifier Gain and adding the Cable Loss and Antenna Correction Factor to the measured reading. The basic equation is as follows:

$$\text{Field Strength (dB}\mu\text{V/m)} = \text{RAW} - \text{AMP} + \text{CBL} + \text{ACF}$$

Where: RAW = Measured level before correction (dBμV)

AMP = Amplifier Gain (dB)

CBL = Cable Loss (dB)

ACF = Antenna Correction Factor (dB/m)

$$\mu\text{V/m} = 10^{\frac{\text{dB}\mu\text{V/m}}{20}}$$

Sample radiated emissions calculation @ 30 MHz

Measurement +Antenna Factor–Amplifier Gain+Cable loss=Radiated Emissions (dBuV/m)

$$25 \text{ dBuV/m} + 17.5 \text{ dB} - 20 \text{ dB} + 1.0 \text{ dB} = 23.5 \text{ dBuV/m}$$

2.3.2 Measurement Uncertainty

Per CISPR 16-4-2	U _{lab}	U _{cispr}
Radiated Disturbance @ 10 meters		
30 – 1,000 MHz	2.25 dB	4.51 dB
Radiated Disturbance @ 3 meters		
30 – 1,000 MHz	2.26 dB	4.52 dB
1 – 6 GHz	2.12 dB	4.25 dB
6 – 18 GHz	2.47 dB	4.93 dB
Conducted Disturbance @ Mains Terminals		
150 kHz – 30 MHz	1.09 dB	2.18 dB
Disturbance Power		
30 MHz – 300 MHz	3.92 dB	4.3 dB

Voltech PM6000A

The estimated combined standard uncertainty for harmonic current and flicker measurements is $\pm 5.0\%$.	Per CISPR 16-4-2 Methods
--	--------------------------

2.3.3 Measurement Uncertainty Immunity

The estimated combined standard uncertainty for ESD immunity measurements is $\pm 8.2\%$.	Per IEC 61000-4-2
The estimated combined standard uncertainty for radiated immunity measurements is ± 4.10 dB.	Per IEC 61000-4-3
The estimated combined standard uncertainty for conducted immunity measurements with CDN is ± 3.66 dB	Per IEC 61000-4-6
The estimated combined standard uncertainty for power frequency magnetic field immunity is $\pm 2.9\%$.	Per IEC 61000-4-8

Thermo KeyTek EMC Pro

The estimated combined standard uncertainty for EFT fast transient immunity measurements is $\pm 2.6\%$.
The estimated combined standard uncertainty for surge immunity measurements is $\pm 2.6\%$.
The estimated combined standard uncertainty for voltage variation and interruption measurements is $\pm 1.74\%$.

The expanded uncertainty at a level of 95% confidence is obtained by multiplying the combined standard uncertainty by a coverage factor of 2. Compliance criteria are not based on measurement uncertainty.

2.4 Calibration Traceability

All measurement instrumentation is traceable to the National Institute of Standards and Technology (NIST). Measurement method complies with ANSI/NCSL Z540-1-1994 and ISO Standard 17025:2005. Equipment calibration records are kept on file at the test facility.

3 Product Information

3.1 Product Description

The Pace 405 wireless video access point allows service providers to securely deliver high quality HD video to any location in a subscriber home. Using state of the art wireless technology including digital beam forming, customers retain traditional “wired” levels of service and quality while service providers enjoy the benefits of shortened installation times and more flexibility in how they deploy their IPTV or OTT services

Key Feature:

- 5GHz 802.11n wireless access point
- 4x4 MIMO (up to 600Mbps phy rate)
- High-Power Transmit For Maximum Coverage
- Gigabit Ethernet port
- Robust quality of service (QoS) and traffic management features
- Simple, push-button wireless setup for wireless set-tops
- TR-069 Management Client
- LEDs: Power, Wireless Signal Quality, Operational Mode (AP/STA), Ethernet Link, Wireless Pairing Indicator

3.2 Equipment Configuration

A description of the equipment configuration is given in the Test Plan Section. The EUT was tested as called for in the test standard and was configured and operated in a manner consistent with its intended use. The EUT was connected to rated power and allowed to reach intended operating conditions. The placement of the EUT system components was guided by the test standard and selected to represent typical installation conditions.

In the case of an EUT that can operate in more than one configuration, preliminary testing was performed to determine the configuration that produced maximum radiation.

The final configuration was selected to produce the worst case radiation for emissions testing and to place the EUT in the most susceptible state for immunity testing.

3.3 Operating Mode

A description of the operation mode is given in the Test Plan Section. In the case of an EUT that can operate in more than one state, preliminary testing was performed to determine the operating mode that produced maximum radiation.

The final operating mode was selected to produce the worst case radiation for emissions testing and to place the EUT in the most susceptible state for immunity testing.

3.4 Unique Antenna Connector

An intentional radiator shall be designed to ensure that no antenna other than that furnished by the responsible party shall be used with the device. The use of a permanently attached antenna or of an antenna that uses a unique coupling to the intentional radiator shall be considered sufficient to comply with the provisions of this Section. The manufacturer may design the unit so that a broken antenna can be replaced by the user, but the use of a standard antenna jack or electrical connector is prohibited. This requirement does not apply to carrier current devices or to devices operated under the provisions of CFR47 Parts 15.211, 15.213, 15.217, 15.219, or 15.221.

3.4.1 Results

The Wireless Video Access Point has 4 internal fixed antennas, 3 onboard PCB dipole antennas and 1 stamped metal loop antenna. Each antenna has the maximum gain of 2dBi. The total directional gain is 8dBi. All antennas are integrated on the PCB. There is no external antenna connection available.

4 Emissions

Testing was performed in accordance with CFR 47 Part 15.247: 2012 and RSS 210 Annex 8: 2010. These test methods are listed under the laboratory's A2LA Scope of Accreditation. This test measures the levels emanating from the EUT, thus evaluating the potential for the EUT to cause radio frequency interference to other electronic devices. Procedures described in section 8 of the standard were used.

4.1 Output Power Requirements

The maximum output power requirement is the maximum equivalent isotropic radiated power delivering at the transmitting antenna under specified conditions of measurements in the presence of modulation.

The maximum output power and harmonics shall not exceed CFR47 Part 15.247 (b3):2012 and RSS 210 A.8.4: 2010

The maximum transmitted power is +30 dBm or 1Watt.

4.1.1 Test Method

The ANSI C63.10-2009 Section 6.10.3.1 conducted method was used to measure the channel power output. The preliminary investigation was performed at different data rate/ chain to determine the highest power output for each mode. The worst findings were conducted on 3 channels in each mode on the sample, S/N 09130M000104, per CFR47 Part 15.247 (b3):2009 and RSS 210 A.8.4; 5725 MHz to 5850 MHz. The worst mode results indicated below.

Test Setup:

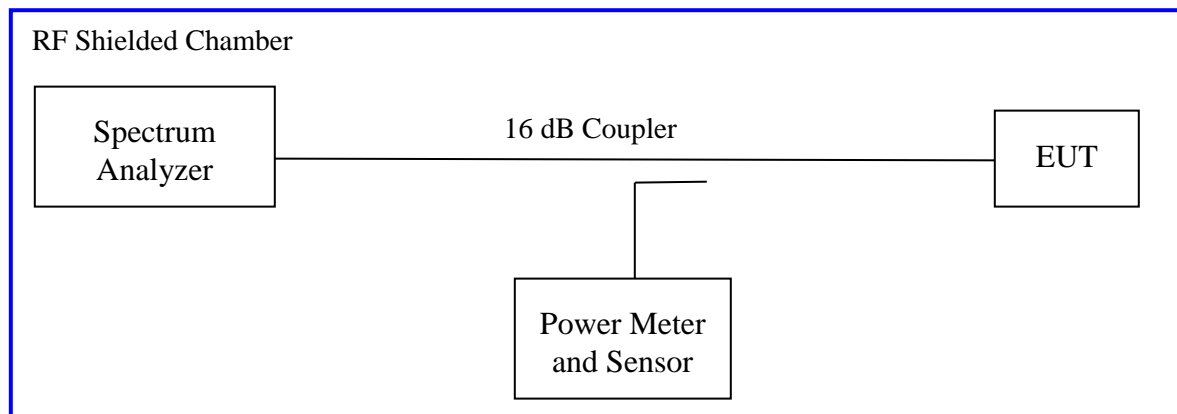

Method AVGSA-1 of "Guidelines for Performing Compliance Measurements on Digital Transmission Systems (DTS) Operating under CFR47 Part 15.247" applies since the EUT continuously transmit; where duty cycle is greater than 98%. Sample detector was used.

Each chain was measured individually and applied the measure-and-sum approach per KDB66291.

4.1.2 Results

As originally tested, the EUT was found to be compliant to the requirements of the test standard(s).

Table 2: RF Output Power at the Antenna Port – Test Results

Test Conditions: Conducted Measurement, Normal Temperature							
Antenna Type: Integrated				Power Setting: See test plan			
Max. Directional Gain: + 8 dBi				Signal State: Modulated at 100%.			
Ambient Temp.: 23 °C				Relative Humidity: 33%			
802.11n (HT20) Mode, 4x4							
Operating Channel	Limit [dBm]	Ch0 [dBm]	Ch1 [dBm]	Ch2 [dBm]	Ch3 [dBm]	Total Power [dBm]	Margin [dB]
5745	28.00	21.19	21.48	21.18	21.67	27.41	-0.59
5785	28.00	21.13	21.61	21.17	21.25	27.31	-0.69
5825	28.00	21.12	21.91	20.97	21.41	27.39	-0.61
Note: 1. The highest output power was observed at HT20 6.5 Mbps, 4 Data Streams. 2. All chains will be on at all time and beam performing. RF output powers were summed per KDB 662911. 3. The total directional gain would be 8dBi; 2dBi +10*Log(4). Per CFR47 Part 15.247 (b) (4), the limit is reduced for every dBi gain exceeding 6dBi. The limit would be 28.00 dBm.							
802.11n (HT40) Mode, 4x4							
Operating Channel	Limit [dBm]	Ch0 [dBm]	Ch1 [dBm]	Ch2 [dBm]	Ch3 [dBm]	Total Power [dBm]	Margin [dB]
5755	28.00	20.74	21.20	20.82	20.93	26.95	-1.05
5795	28.00	20.42	20.80	20.53	20.23	26.52	-1.48
Note: 1. The highest output power was observed at HT40 13.5 Mbps, 4 Data Streams. 2. All chains will be on at all time and beam performing. RF output powers were summed per KDB 662911. 3. The total directional gain would be 8dBi; 2dBi +10*Log(4). Per CFR47 Part 15.247 (b) (4), the limit is reduced for every dBi gain exceeding 6dBi. The limit would be 28.00 dBm.							

Table 3: Average Output Power at the Antenna Port – Reference Only

Test Conditions: Conducted Measurement, Normal Temperature							
Antenna Type: Integrated				Power Setting: See test plan			
Max. Directional Gain: + 8 dBi				Signal State: Modulated at 100%.			
Ambient Temp.: 23 °C				Relative Humidity: 33%			
802.11n (HT20) Mode, 4x4							
Operating Channel	Limit [dBm]	Ch0 [dBm]	Ch1 [dBm]	Ch2 [dBm]	Ch3 [dBm]	Total Power [dBm]	Margin [dB]
5745		20.89	21.15	20.93	21.49	27.15	
5785		21.08	21.55	21.17	21.16	27.26	
5825		21.04	21.83	20.99	21.36	27.34	
Note: The highest output power was observed at HT20 6.5 Mbps, 4 Data Streams.							
802.11n (HT40) Mode, 4x4							
Operating Channel	Limit [dBm]	Ch0 [dBm]	Ch1 [dBm]	Ch2 [dBm]	Ch3 [dBm]	Total Power [dBm]	Margin [dB]
5755		20.42	20.80	20.53	20.23	26.52	
5795		20.43	21.16	20.56	20.21	26.62	
Note: The highest output power was observed at HT40 13.5 Mbps, 4 Data Streams.							

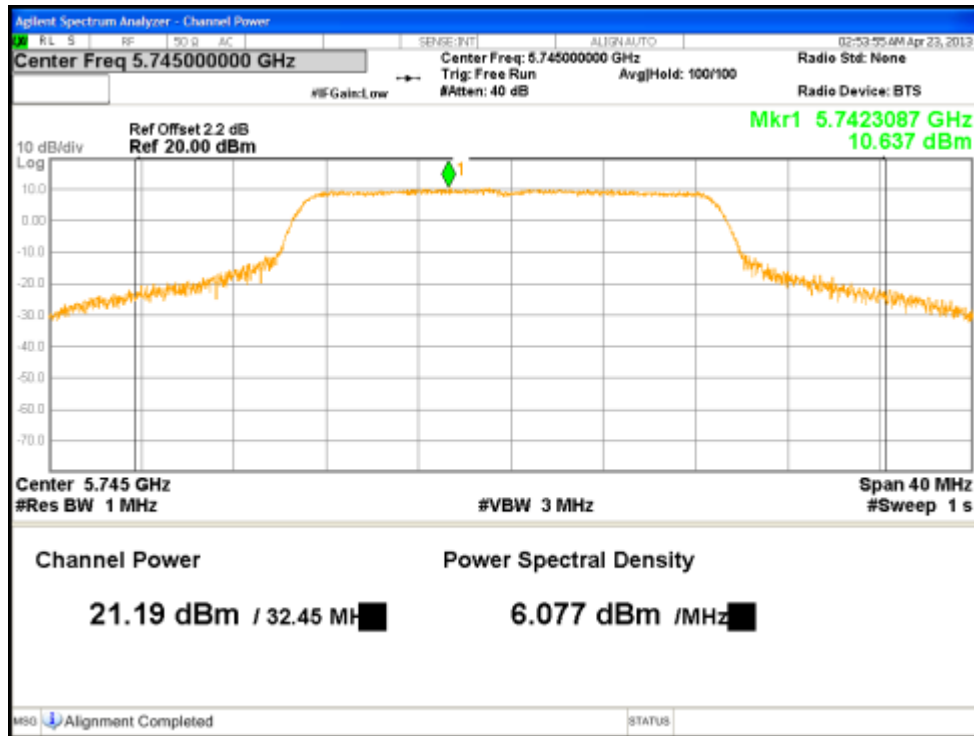

Figure 1: Maximum Transmitted Power, 5745 MHz at HT20, Chain 0

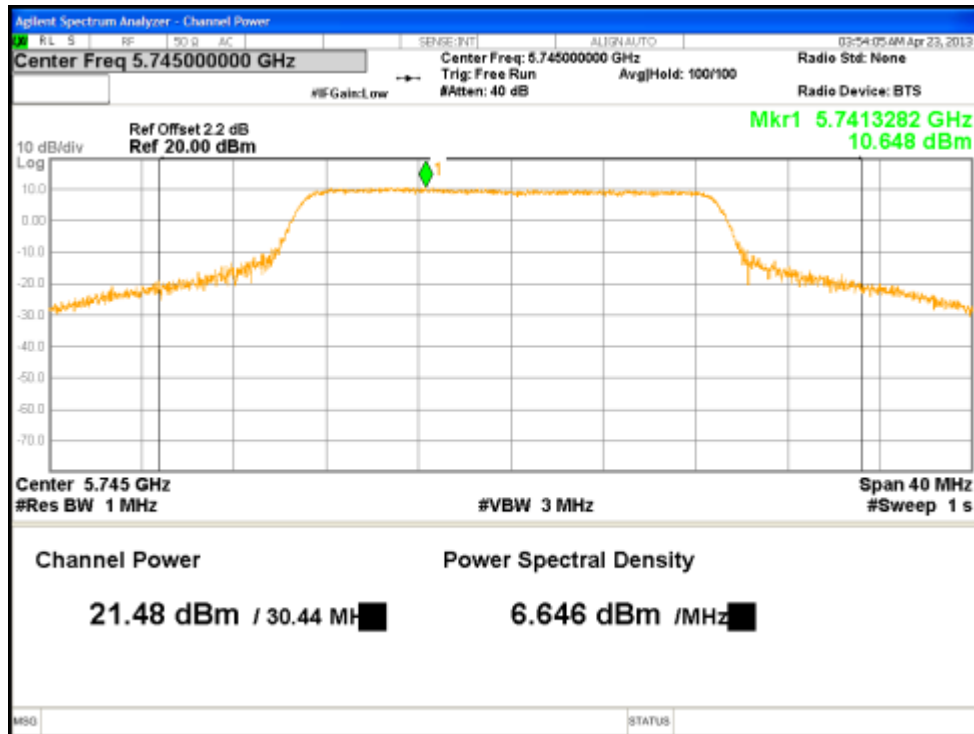

Figure 2: Maximum Transmitted Power, 5745 MHz at HT20, Chain 1

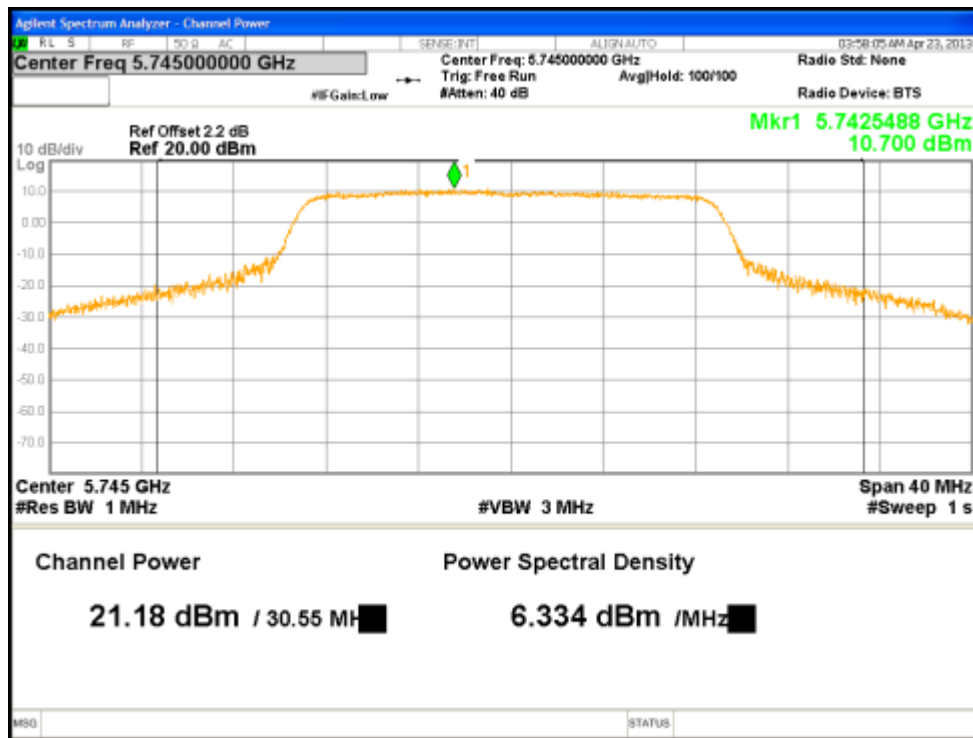

Figure 3: Maximum Transmitted Power, 5745 MHz at HT20, Chain 2

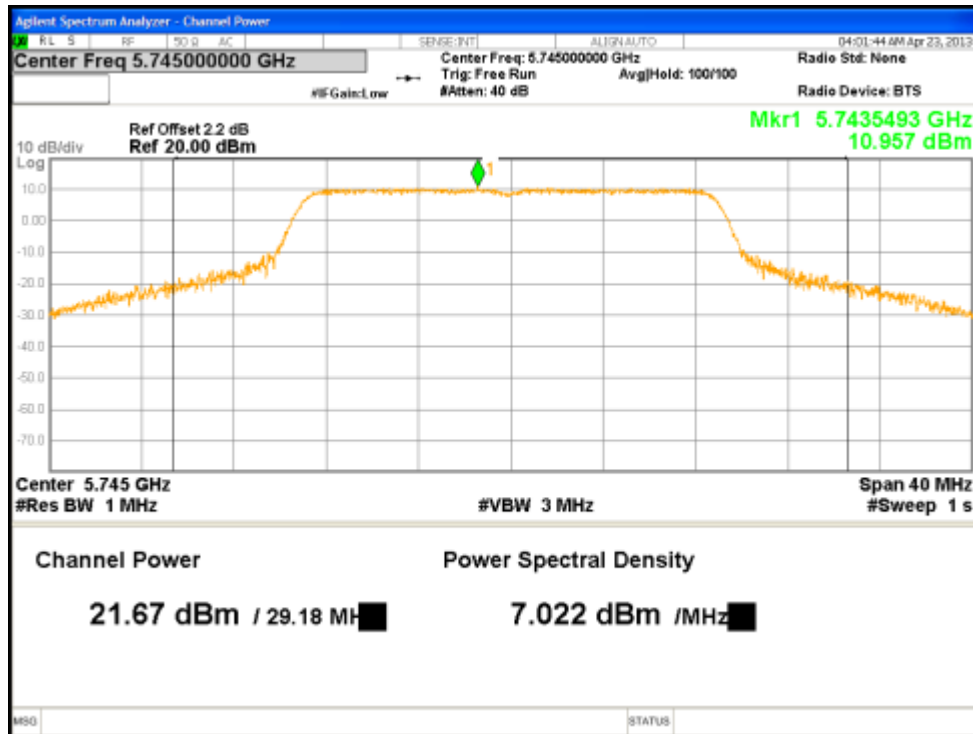

Figure 4: Maximum Transmitted Power, 5745 MHz at HT20, Chain 3

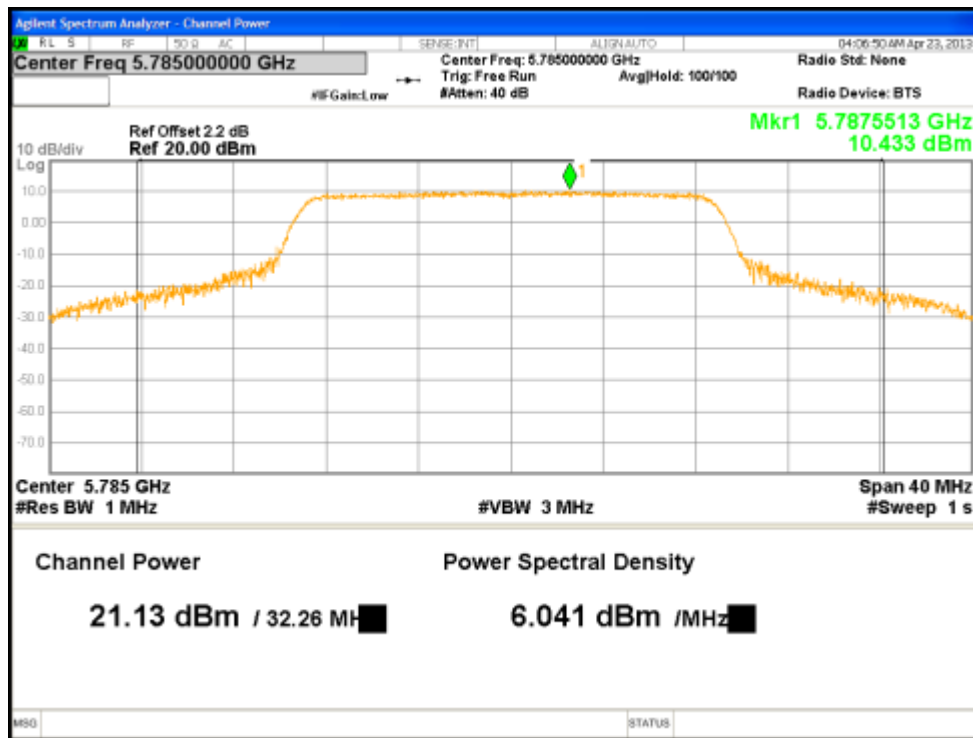

Figure 5: Maximum Transmitted Power, 5785MHz at HT20, Chain 0

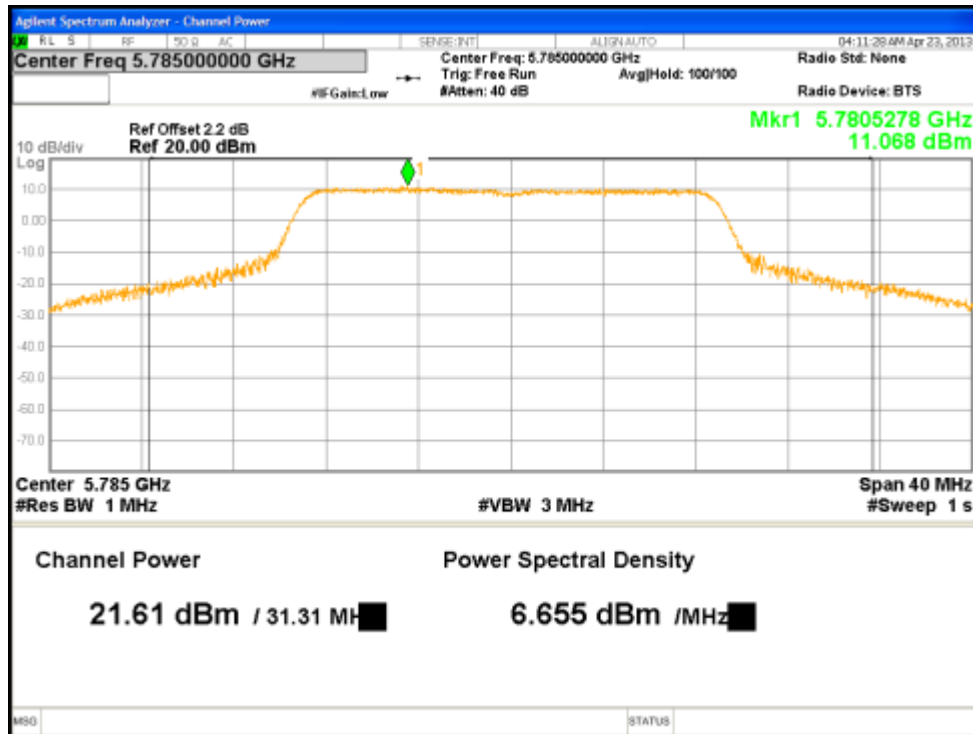

Figure 6: Maximum Transmitted Power, 5785MHz at HT20, Chain 1

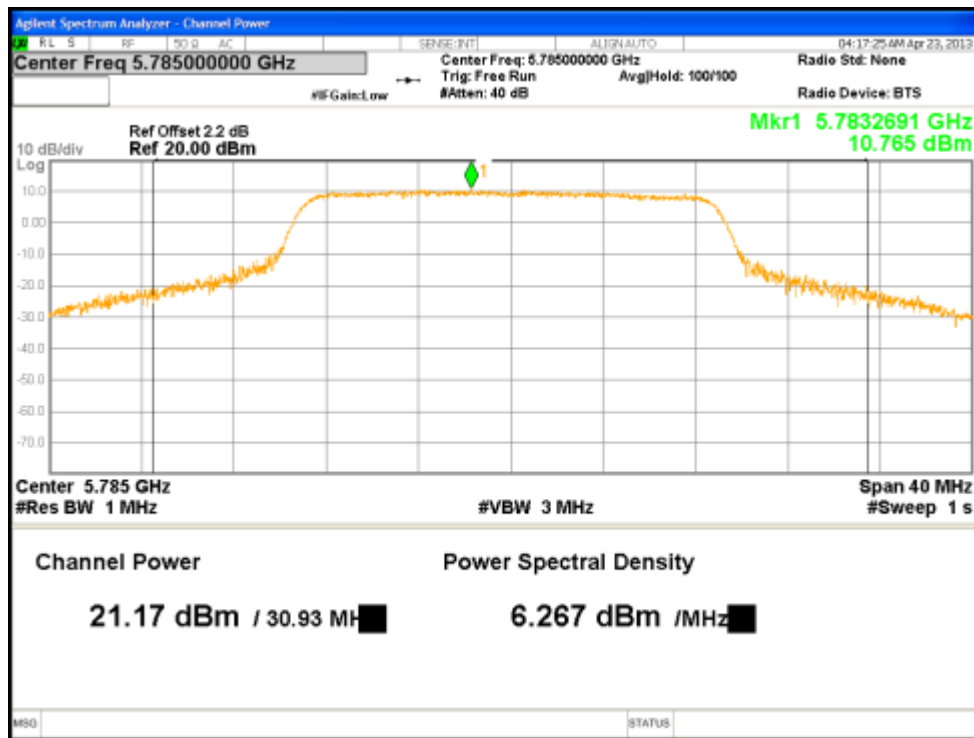

Figure 7: Maximum Transmitted Power, 5785MHz at HT20, Chain 2

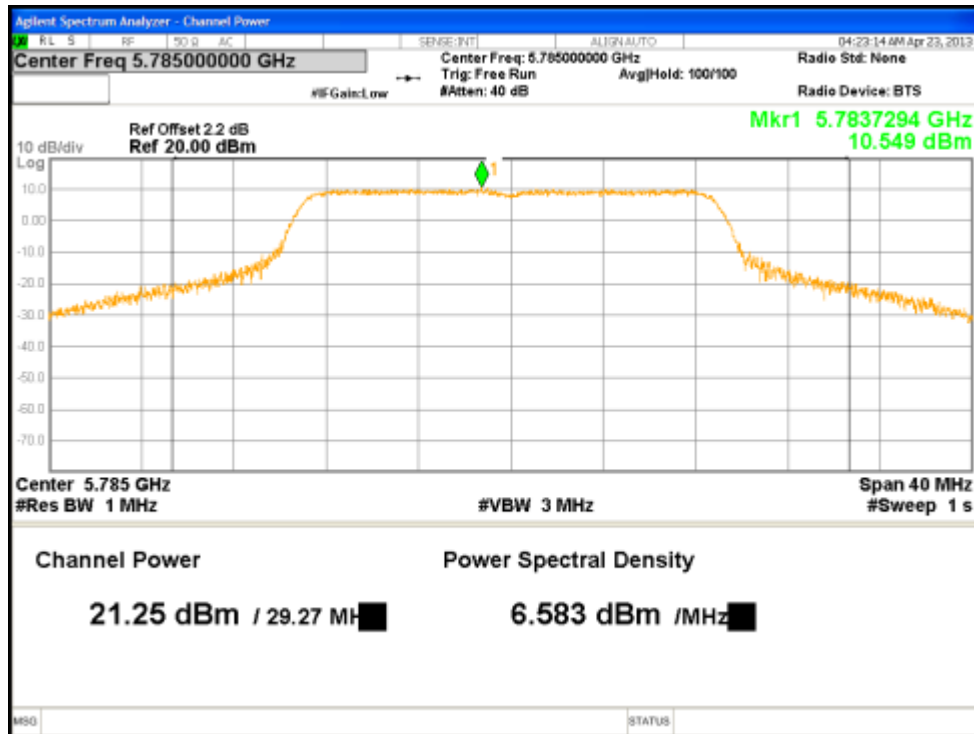

Figure 8: Maximum Transmitted Power, 5785MHz at HT20, Chain 3

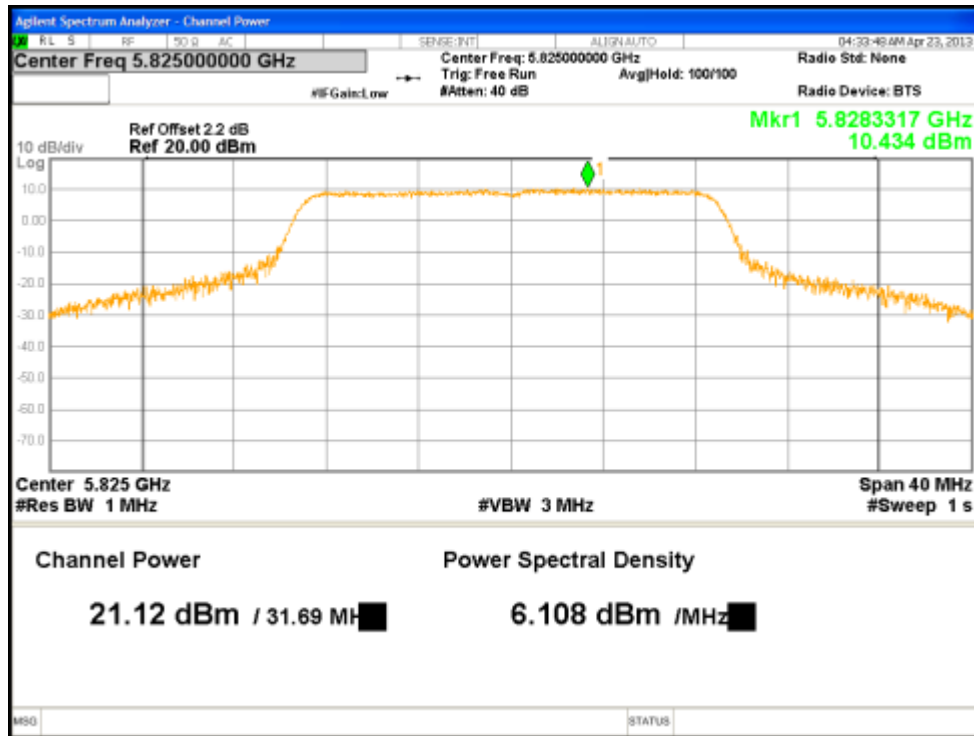

Figure 9: Maximum Transmitted Power, 5825MHz at HT20, Chain 0

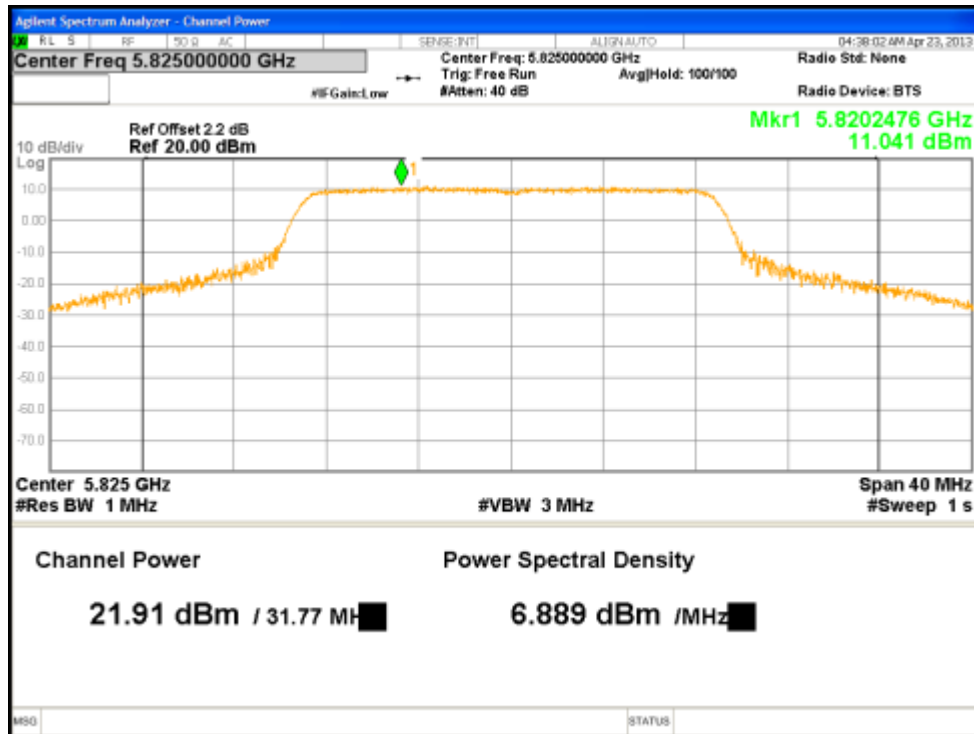

Figure 10: Maximum Transmitted Power, 5825MHz at HT20, Chain 1

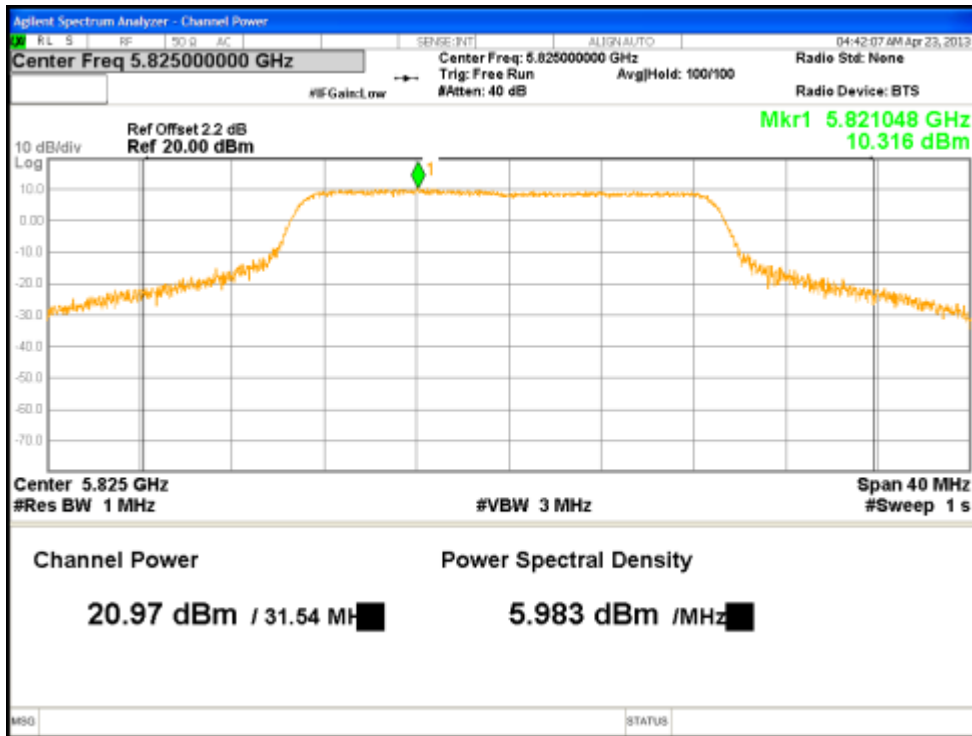

Figure 11: Maximum Transmitted Power, 5825MHz at HT20, Chain 2

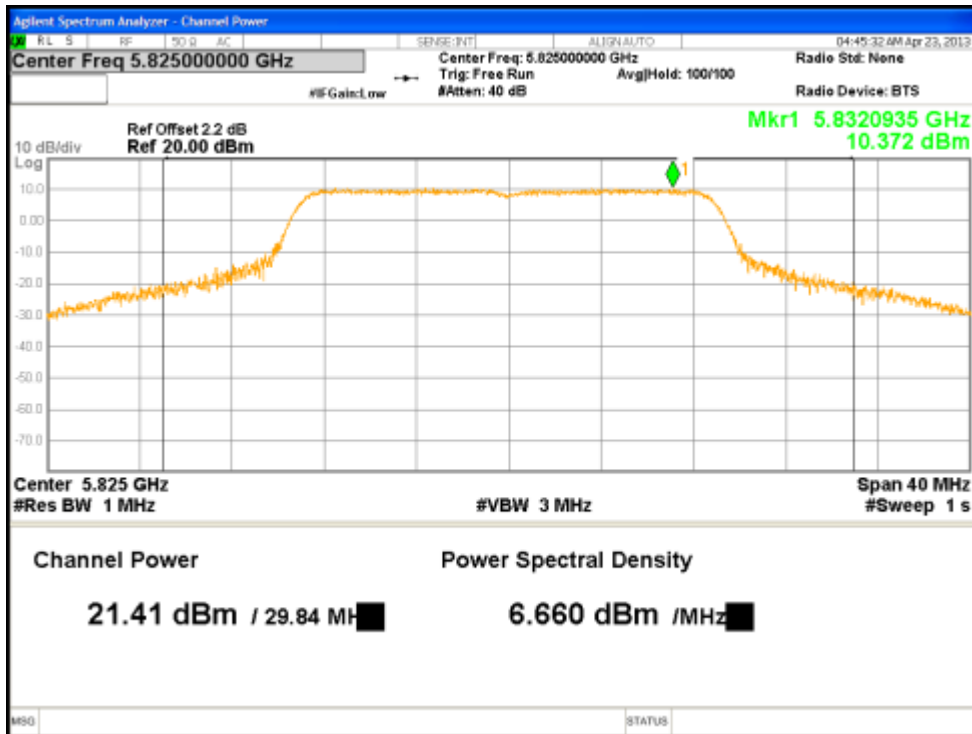

Figure 12: Maximum Transmitted Power, 5825MHz at HT20, Chain 3

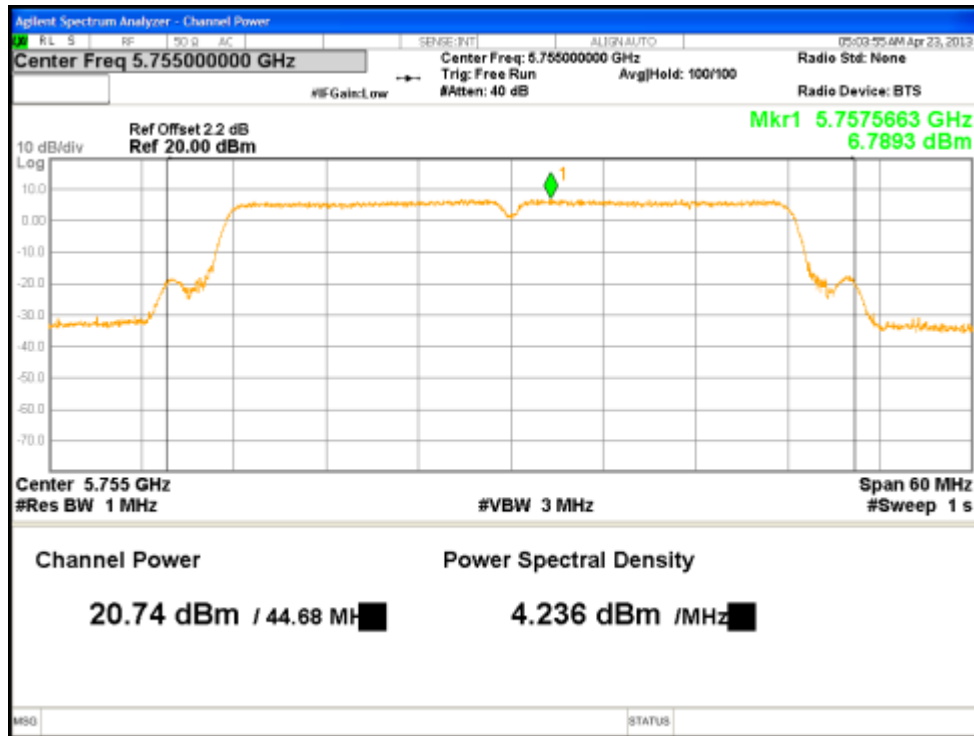

Figure 13: Maximum Transmitted Power, 5755MHz at HT40, Chain 0

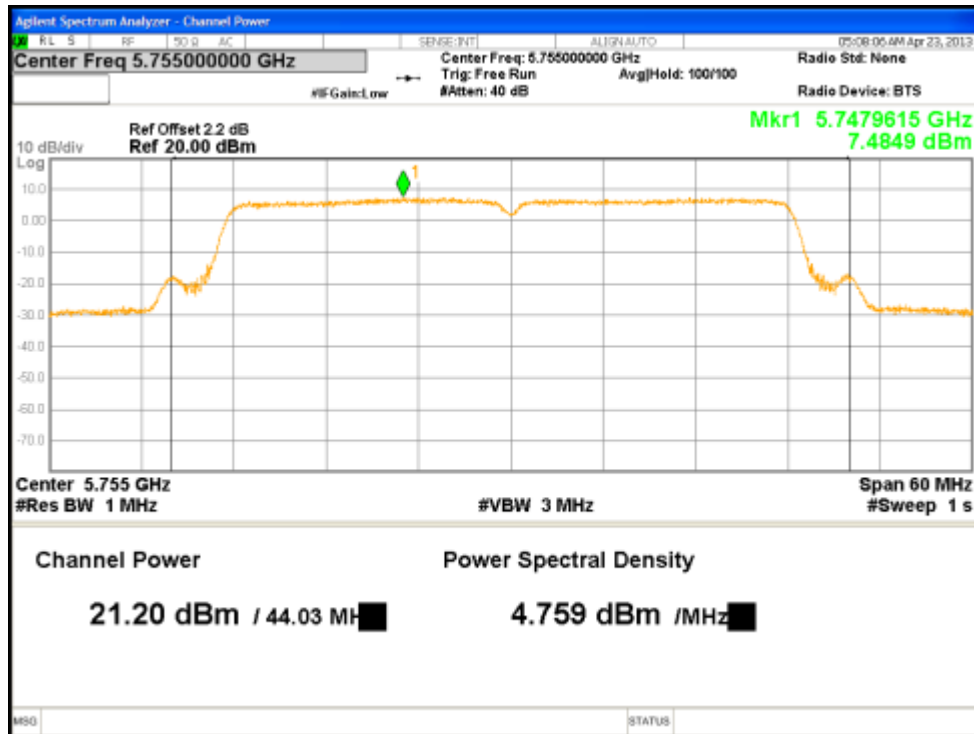

Figure 14: Maximum Transmitted Power, 5755MHz at HT40, Chain 1

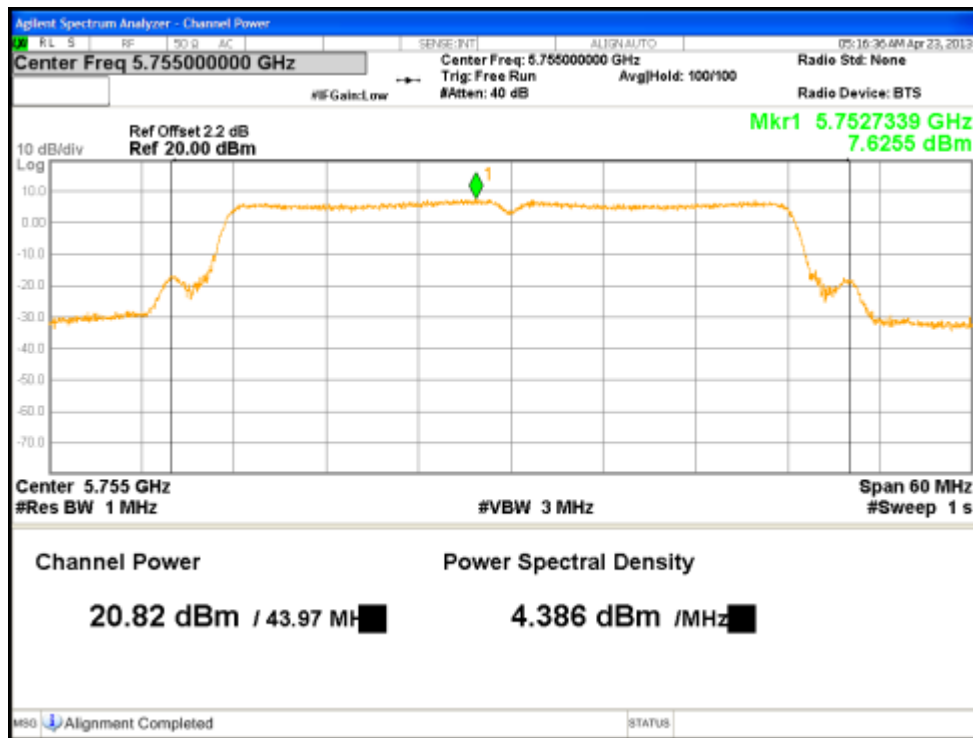

Figure 15: Maximum Transmitted Power, 5755MHz at HT40, Chain 2

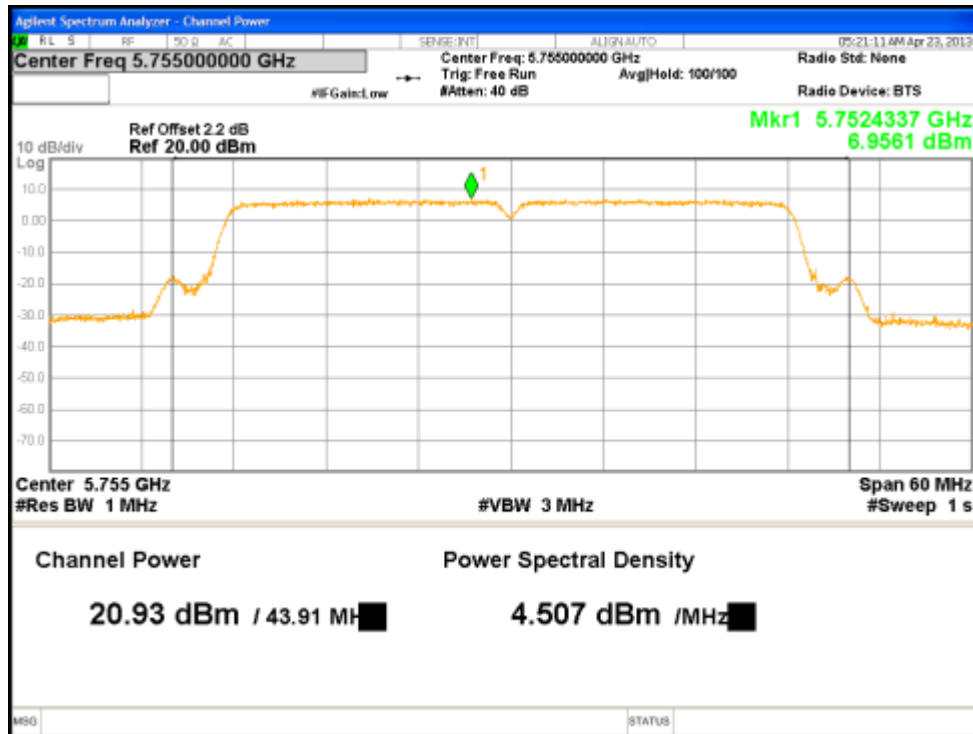

Figure 16: Maximum Transmitted Power, 5755MHz at HT40, Chain 3

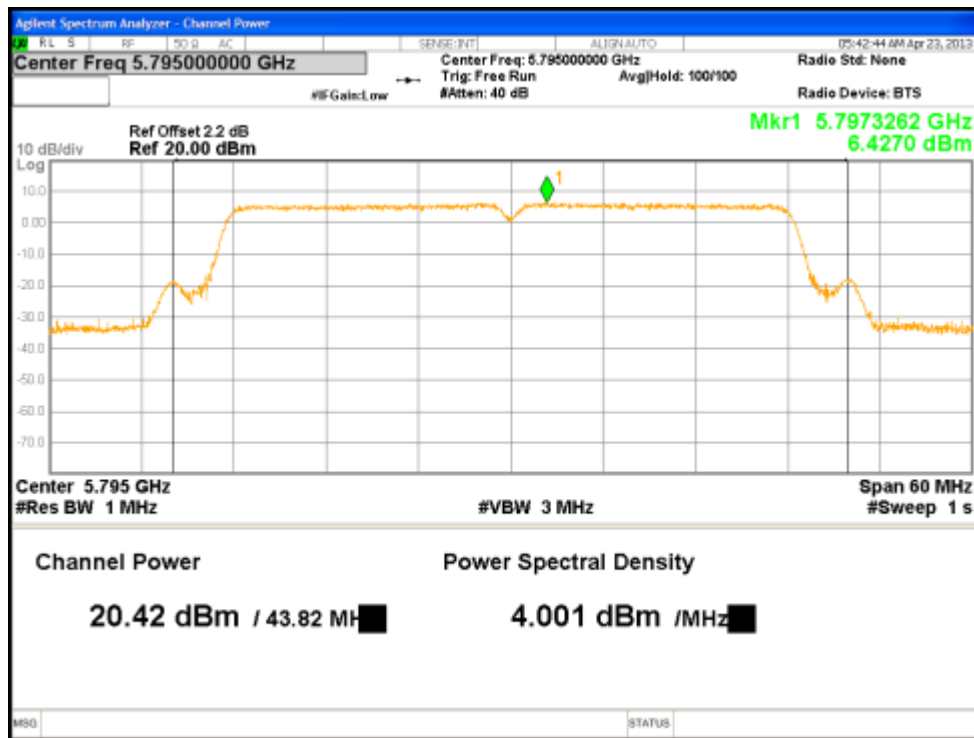

Figure 17: Maximum Transmitted Power, 5795MHz at HT40, Chain 0

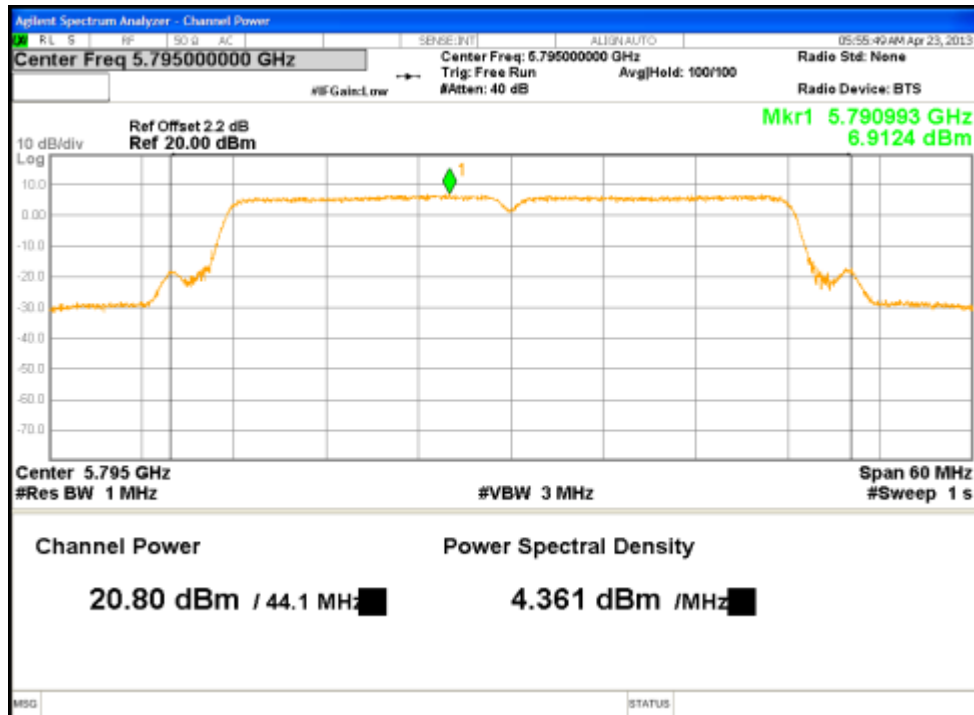

Figure 18: Maximum Transmitted Power, 5795MHz at HT40, Chain 1

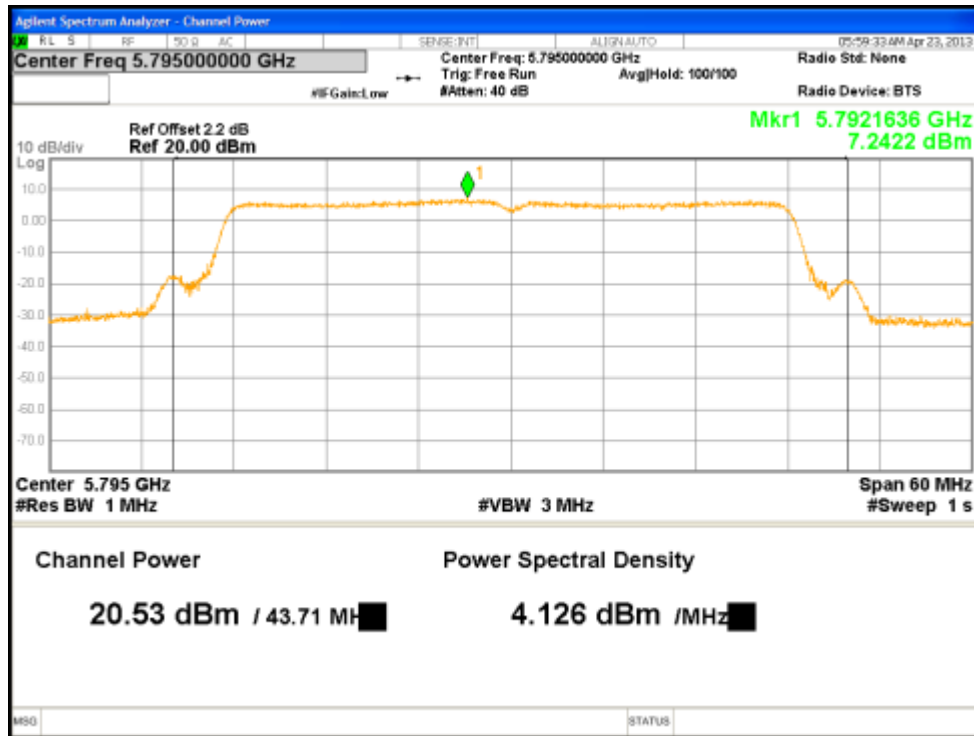

Figure 19: Maximum Transmitted Power, 5795MHz at HT40, Chain 2

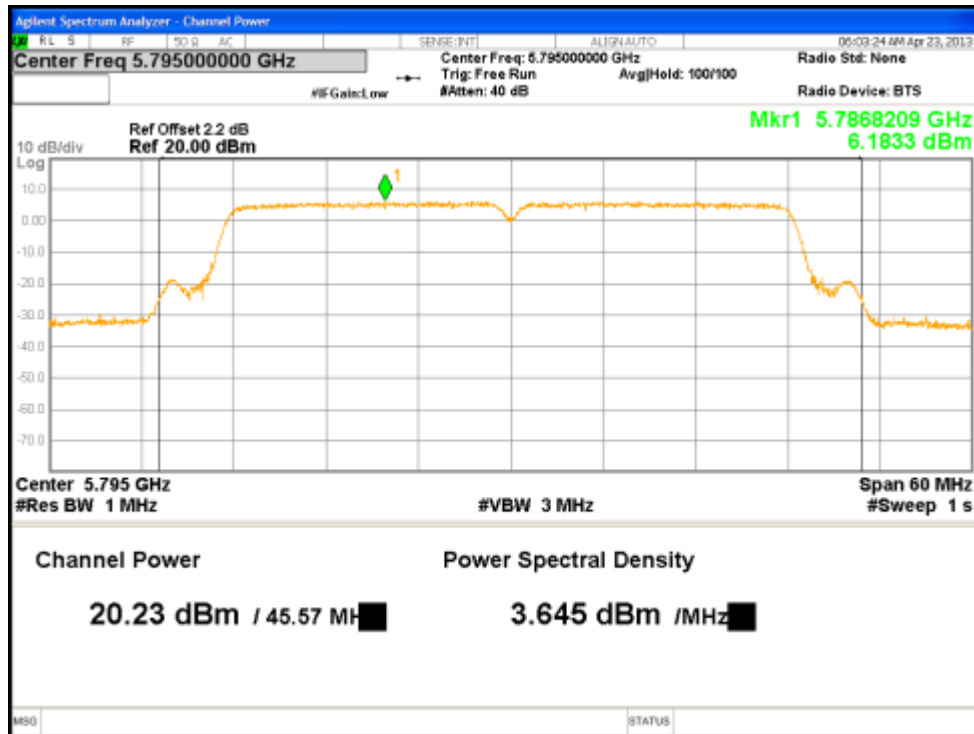

Figure 20: Maximum Transmitted Power, 5795MHz at HT40, Chain 3

4.2 Occupied Bandwidth

The occupied bandwidth is measured at an amplitude level reduced from the reference level by a specified ratio. The reference level is the level of the highest amplitude signal observed from the transmitter at the fundamental frequency.

The 99% bandwidth is the bandwidth in which 99% of the transmitted power occupied.

The DTS bandwidth is defined the bandwidth of 6 dBr from highest transmitted level of the fundamental frequency.

The bandwidth shall be at least 500 kHz per Section CFR47 15.247(a2) 2012 and RSS Gen Sect. 4.4.1: 2010.

4.2.1 Test Method

The conducted method was used to measure the occupied bandwidth. The measurement was performed with modulation per CFR47 15.247(a2) 2012 and RSS Gen Sect. 4.4.1:2010. The preliminary investigation was performed to find the narrowest 6 dB bandwidth for each operational mode at different data rates. This worst finding was performed on 3 channels in each operating frequency range; 5725 MHz to 5850 MHz on the sample, S/N 09130M000104. The results indicated below.

Test Setup:

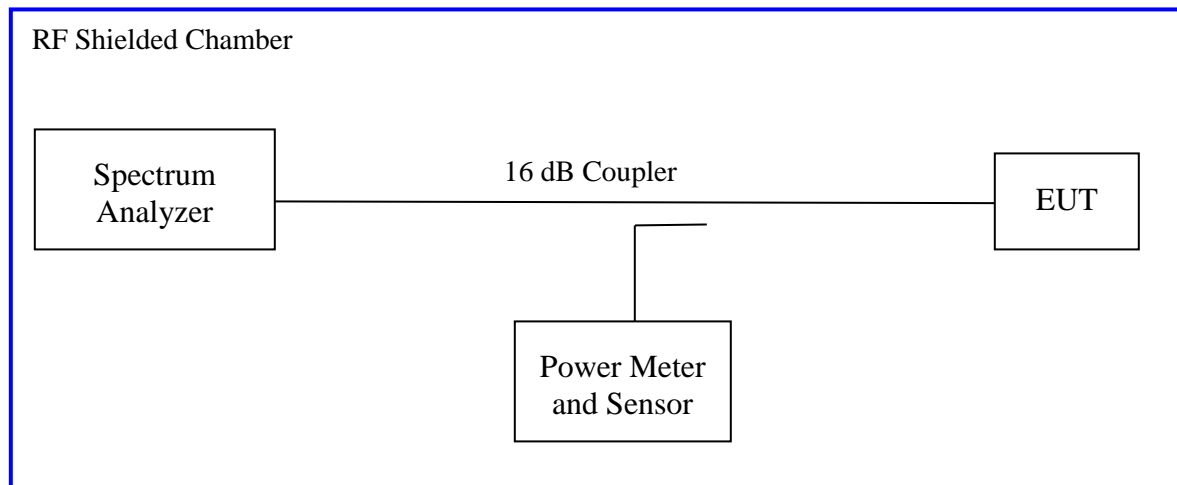

4.2.2 Results

These occupied bandwidth measurements were taken for references only.

Table 4: Occupied Bandwidth – Test Results

Test Conditions: Conducted Measurement, Normal Temperature and Voltage only						
Antenna Type: Integrated			Power Setting: See test plan			
Max. Directional Gain: + 8 dBi			Signal State: Modulated at 100%.			
Ambient Temp.: 22 °C			Relative Humidity: 30%			
Bandwidth (MHz) for 802.11n HT20						
Freq. (MHz)	Limit (kHz)	DTS Bandwidth (MHz)				Results
		Ch0	Ch1	Ch2	Ch3	
5745	500	17.604	17.679	17.574	17.634	Pass
5785	500	17.619	17.634	17.589	17.619	Pass
5825	500	17.559	17.604	17.634	17.619	Pass
Freq. (MHz)	Limit (kHz)	99% Bandwidth (MHz)				Results
		Ch0	Ch1	Ch2	Ch3	
5745		18.124	18.375	18.037	18.115	
5785		18.123	18.397	18.054	18.118	
5825		18.180	18.326	18.159	18.127	
Note: The narrowest bandwidth was observed at 802.11n HT20, 6.5 Mbps						
Bandwidth (MHz) for 802.11n HT40						
Freq. (MHz)	Limit (kHz)	DTS Bandwidth (MHz)				Results
		Ch0	Ch1	Ch2	Ch3	
5755	500	36.293	36.293	36.268	26.293	Pass
5795	500	36.293	36.143	36.293	36.293	Pass
Freq. (MHz)	Limit (kHz)	99% Bandwidth (MHz)				Results

		Ch0	Ch1	Ch2	Ch3	Results
5755		36.488	36.649	36.634	36.251	
5795		36.492	36.709	36.610	36.257	

Note: The bandwidth was observed at 802.11n HT40, 13.5 Mbps.

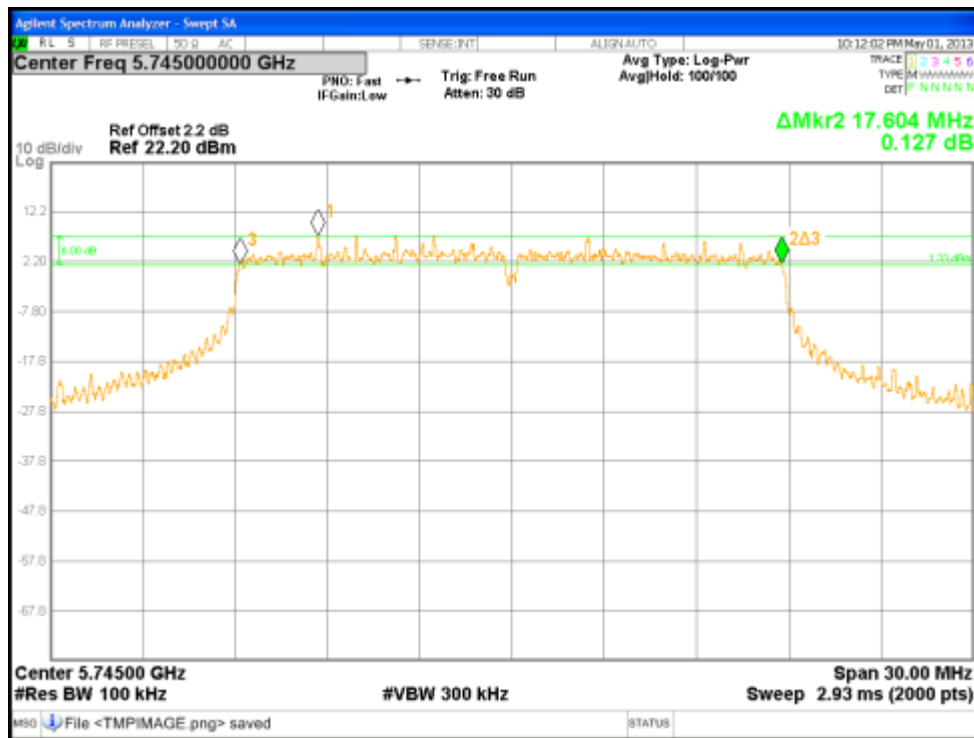

Figure 21: DTS Bandwidth at 5745 MHz, Chain 0

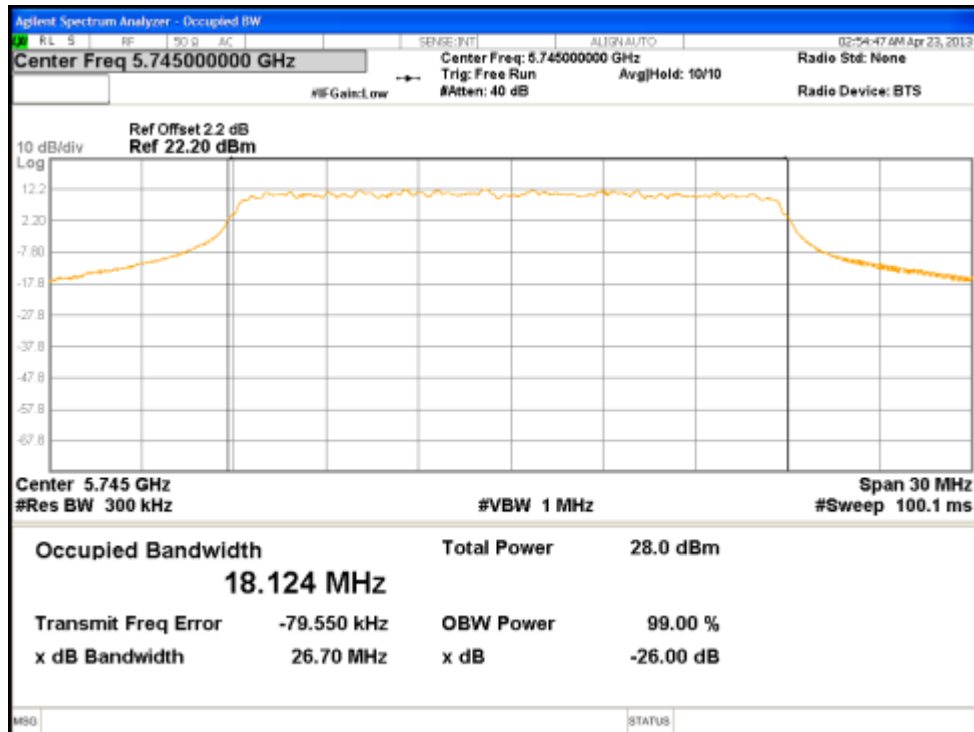

Figure 22: 99% Bandwidth at 5745 MHz, Chain 0

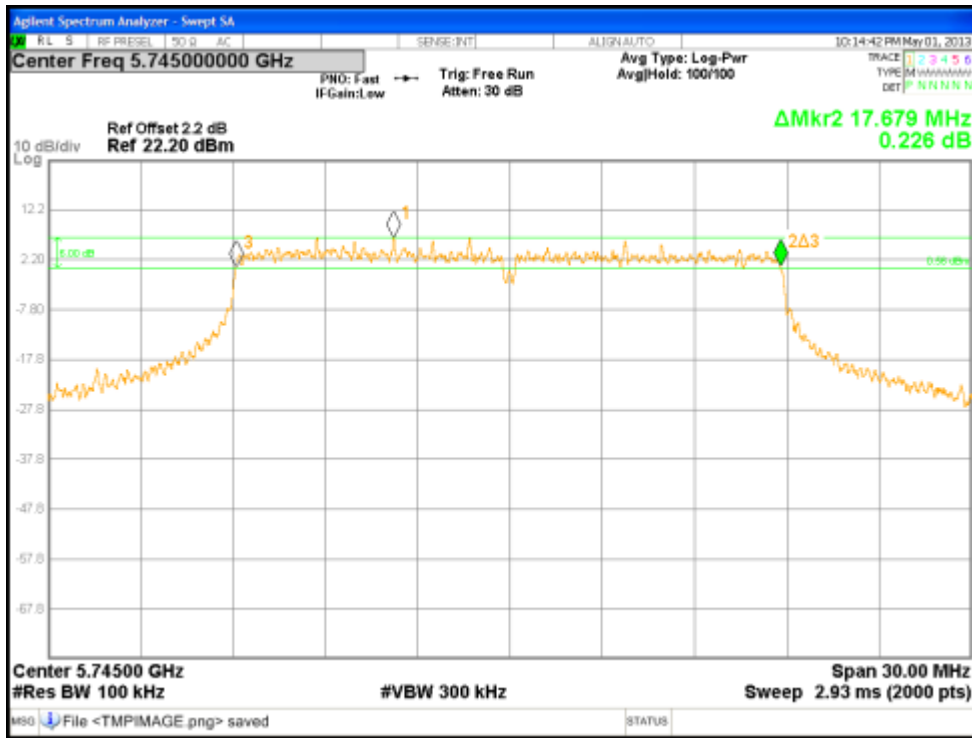

Figure 23: DTS Bandwidth at 5745 MHz, Chain 1

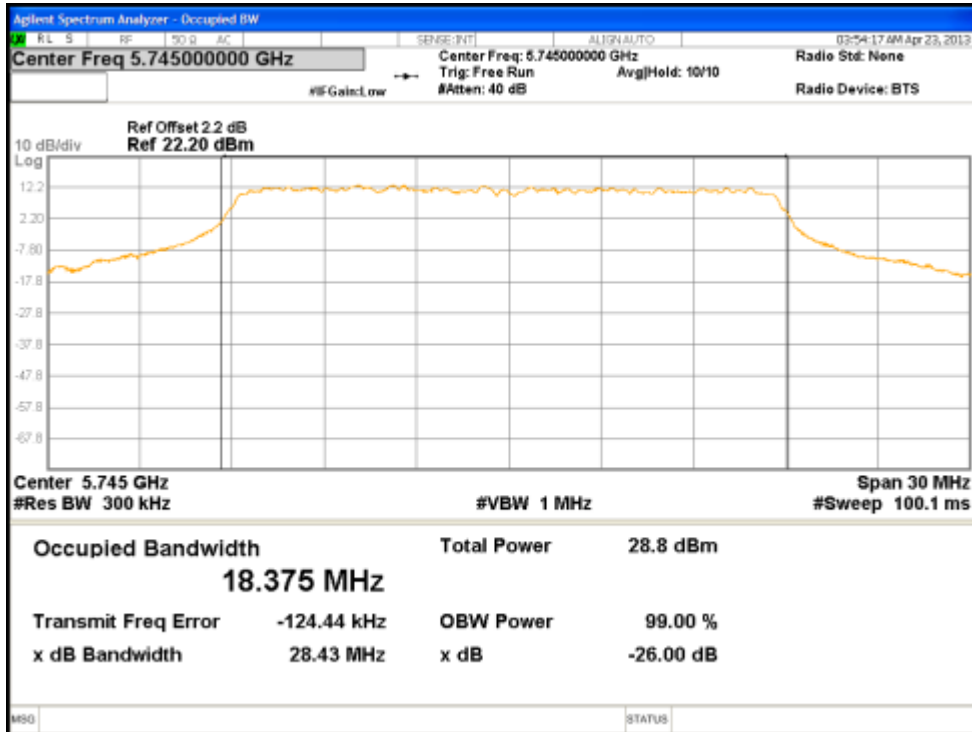

Figure 24: 99% Bandwidth at 5745 MHz, Chain 1

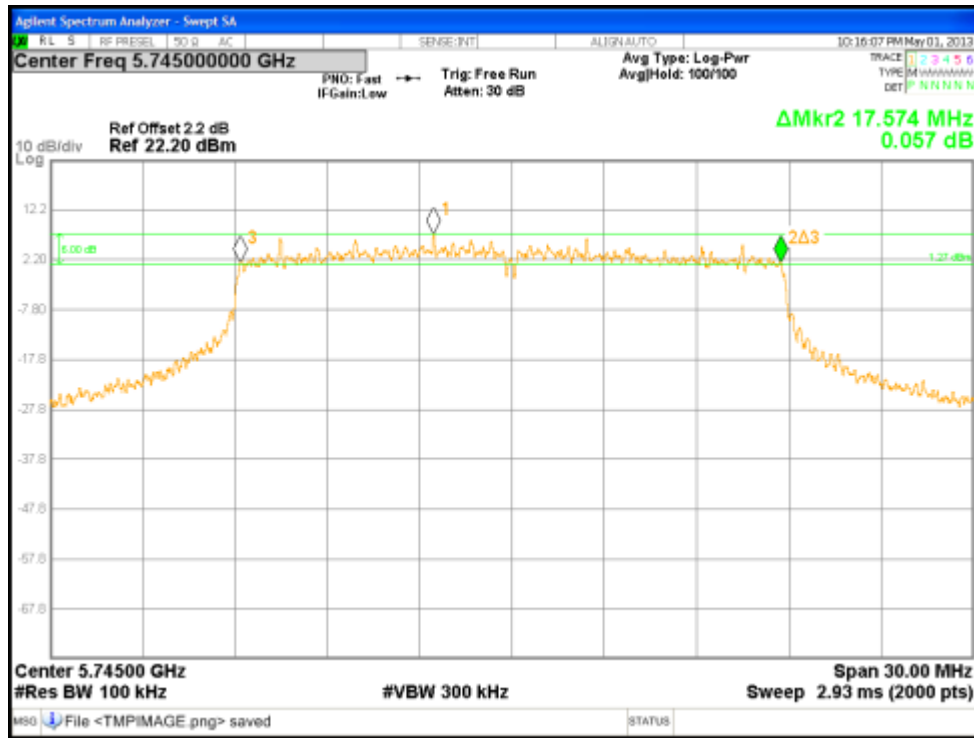

Figure 25: DTS Bandwidth at 5745 MHz, Chain 2

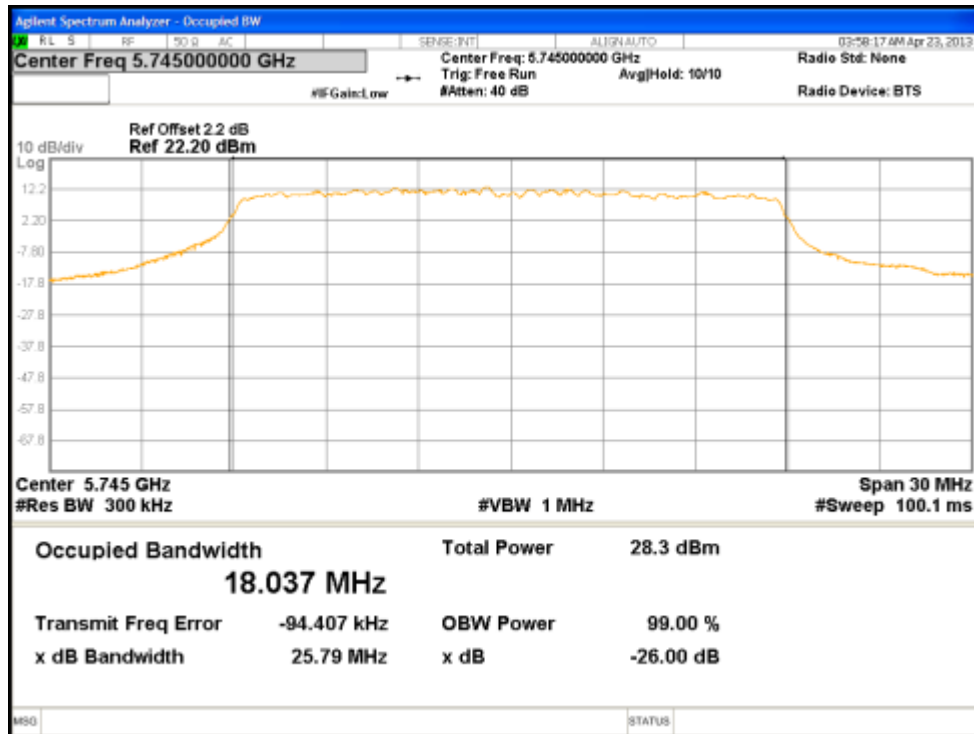

Figure 26: 99% Bandwidth at 5745 MHz, Chain 2

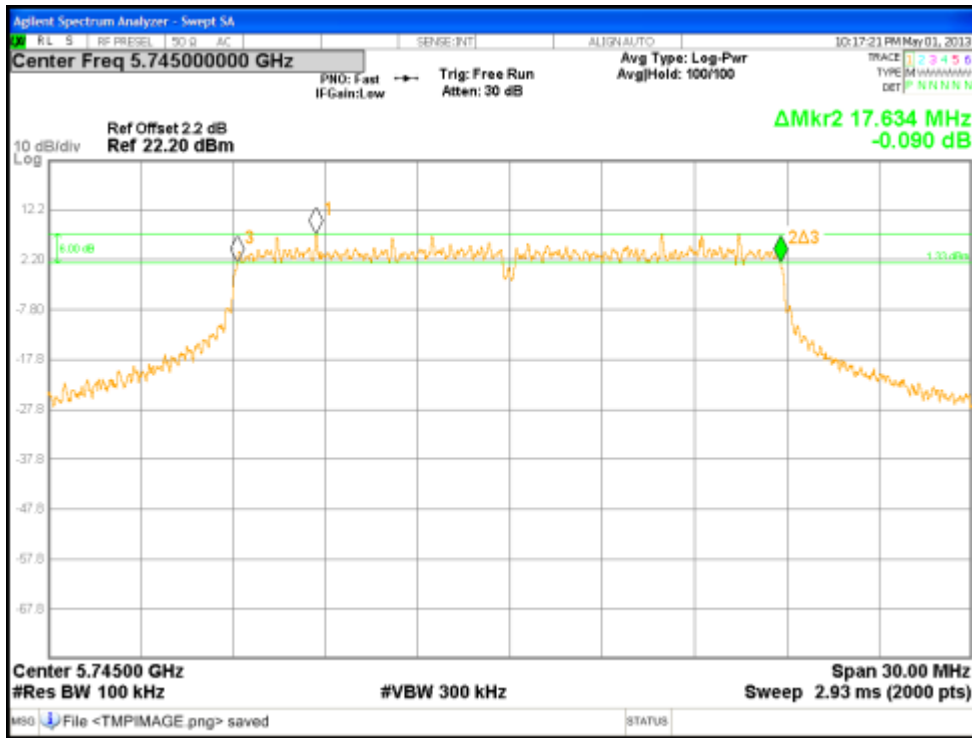

Figure 27: DTS Bandwidth at 5745 MHz, Chain 3

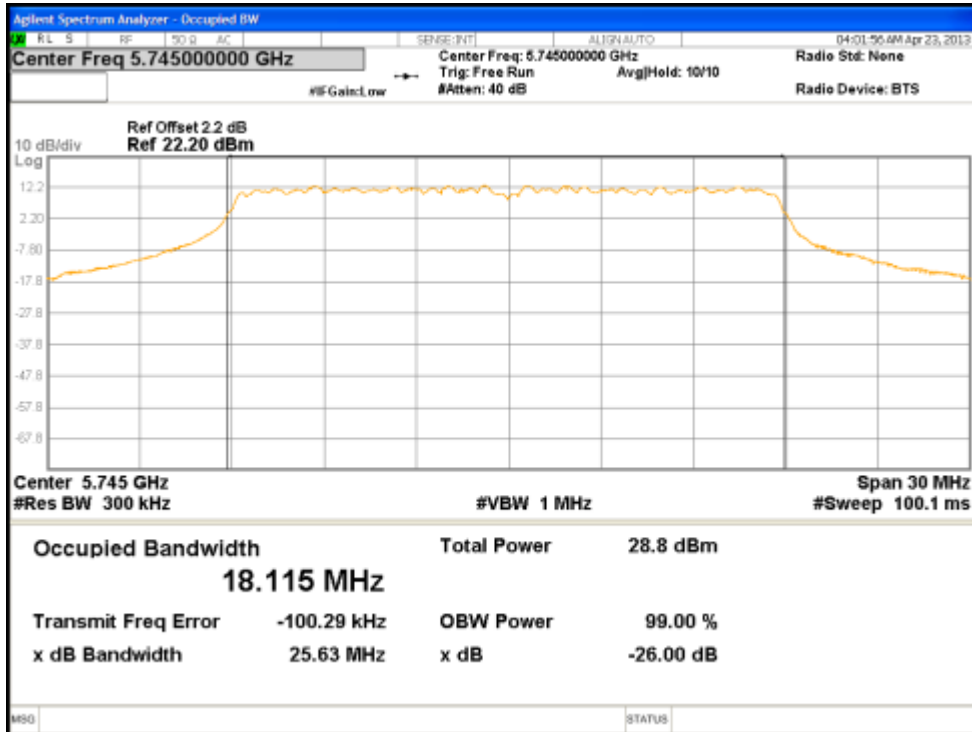

Figure 28: 99% Bandwidth at 5745 MHz, Chain 3

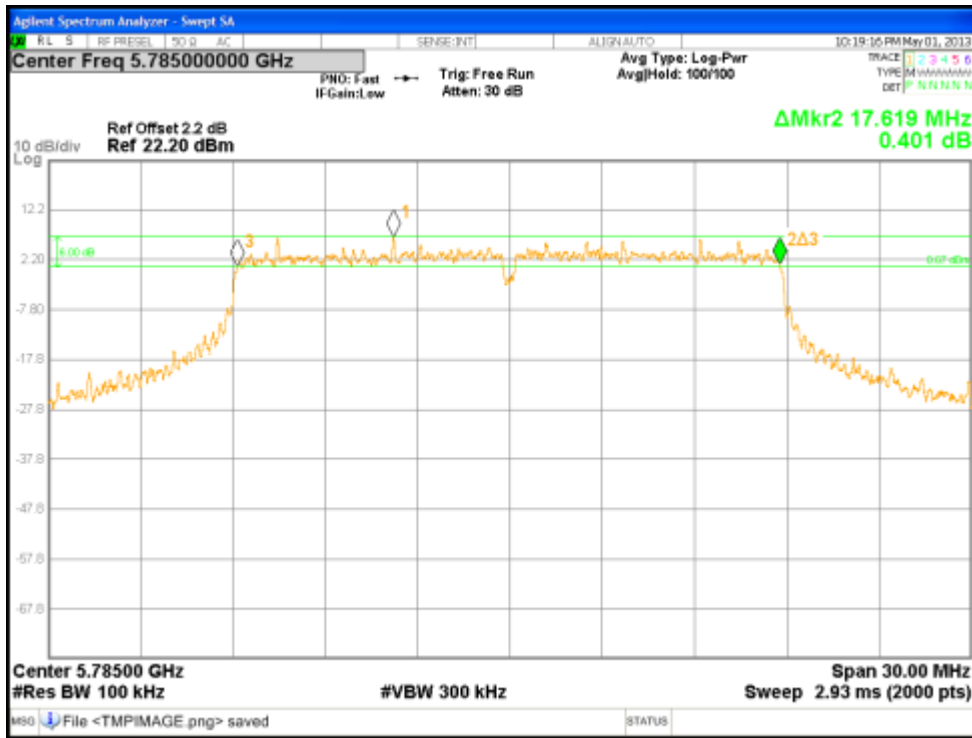

Figure 29: DTS Bandwidth at 5785 MHz, Chain 0

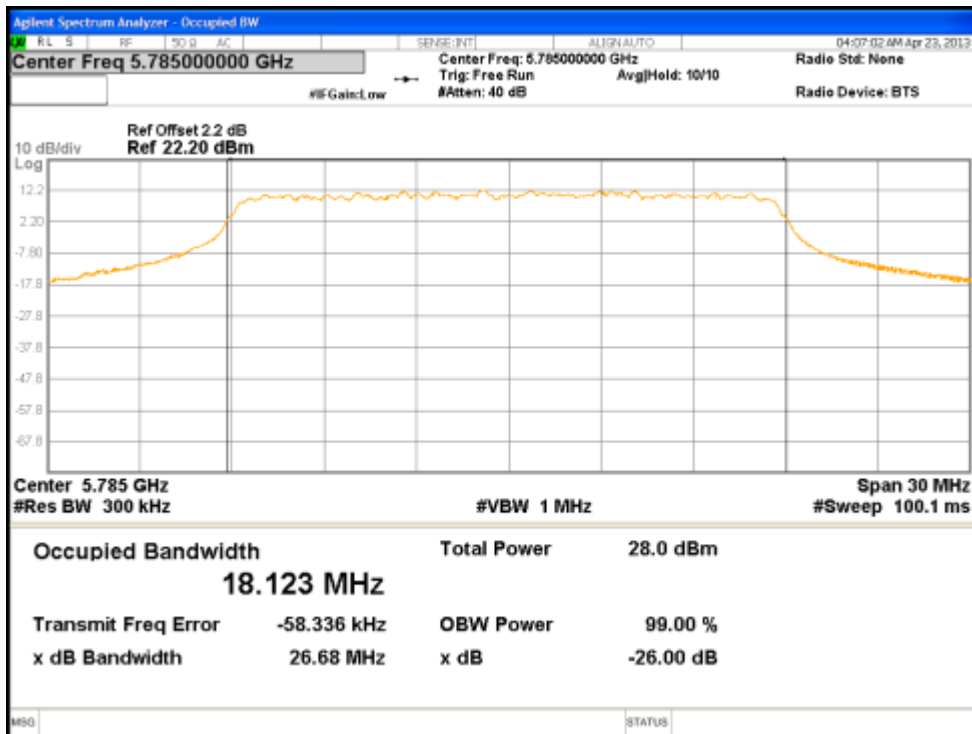

Figure 30: 99% Bandwidth at 5785 MHz, Chain 0

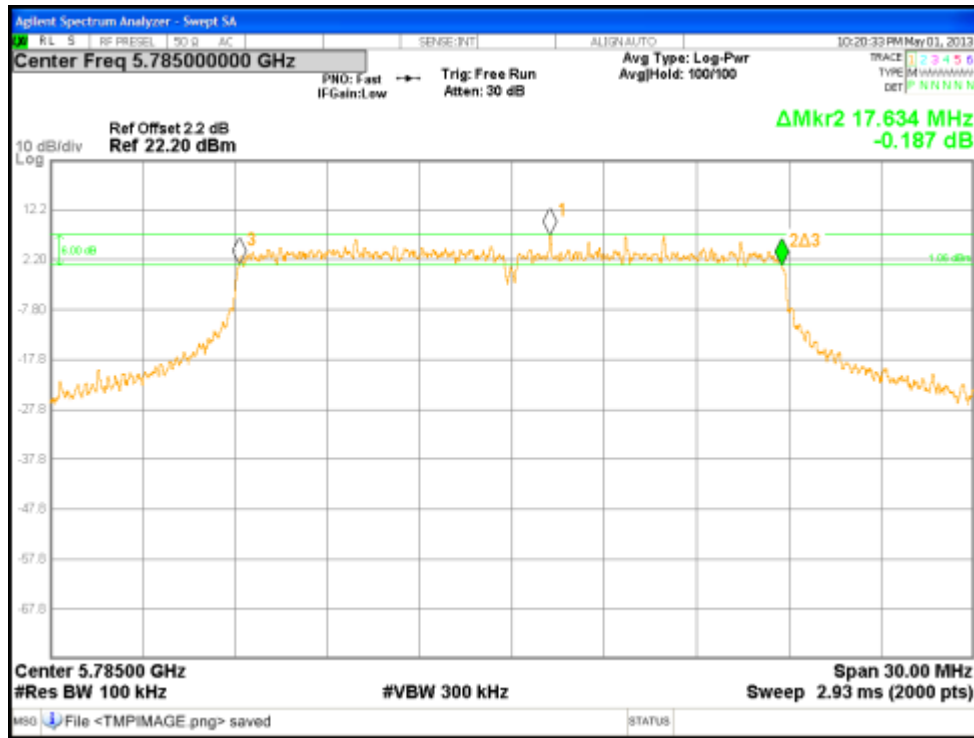

Figure 31: DTS Bandwidth at 5785 MHz, Chain 1

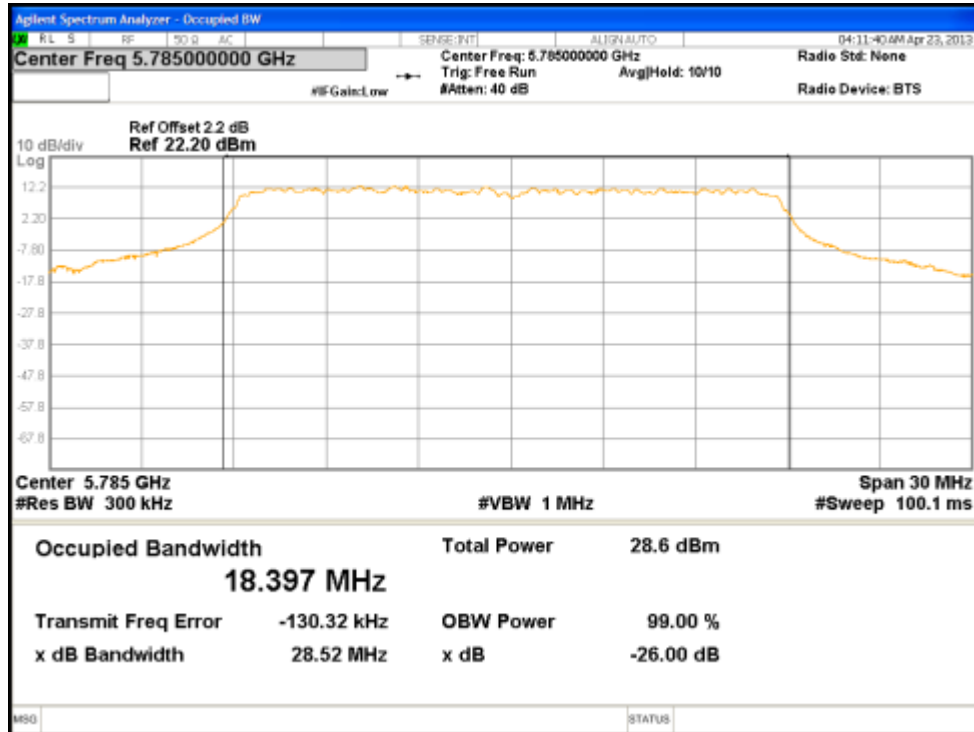

Figure 32: 99% Bandwidth at 5785 MHz, Chain 1

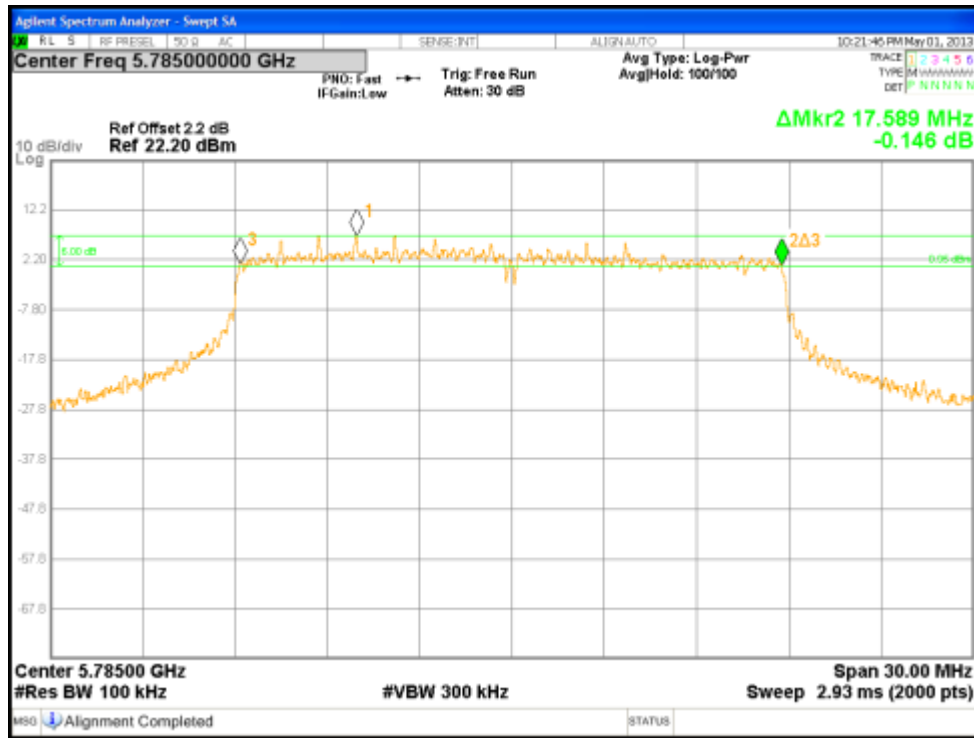

Figure 33: DTS Bandwidth at 5785 MHz, Chain 2

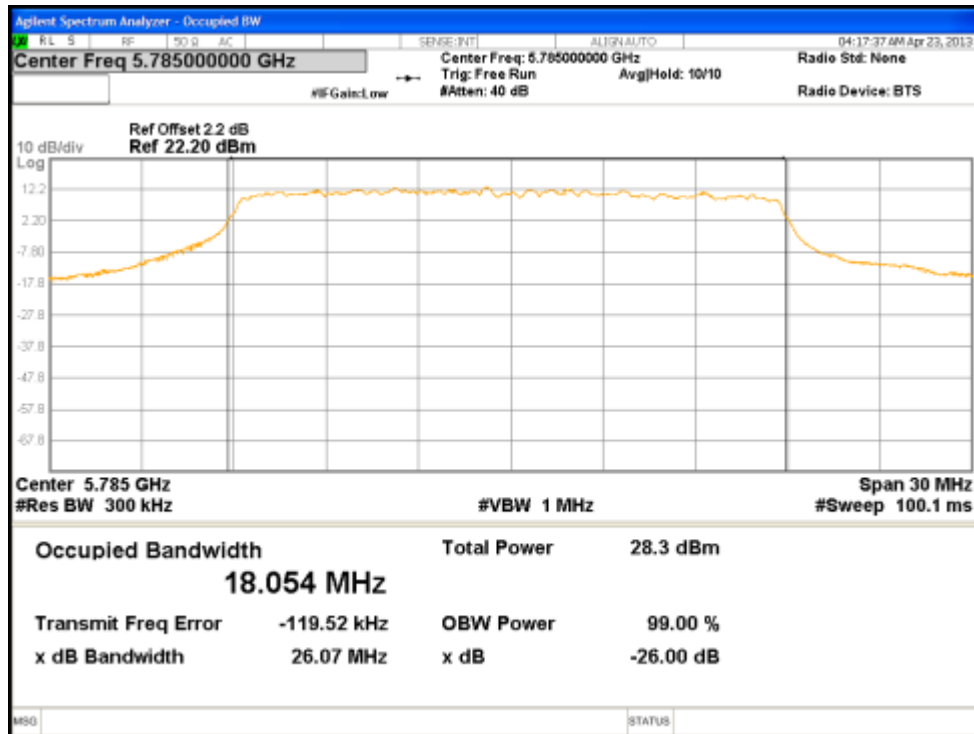

Figure 34: 99% Bandwidth at 5785 MHz, Chain 2

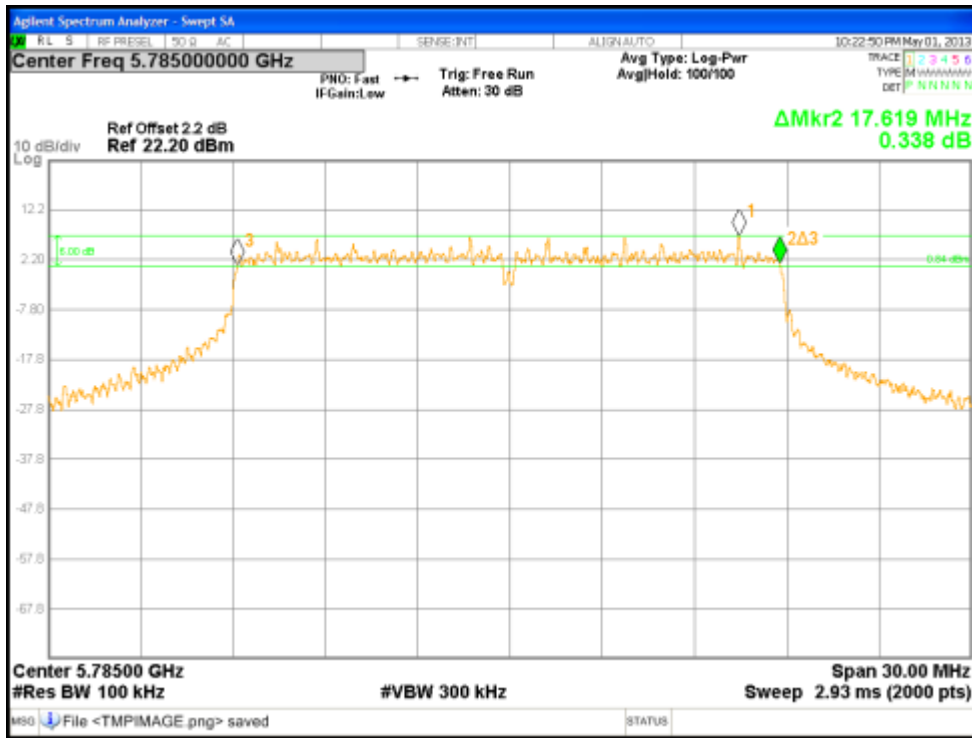

Figure 35: DTS Bandwidth at 5785 MHz, Chain 3

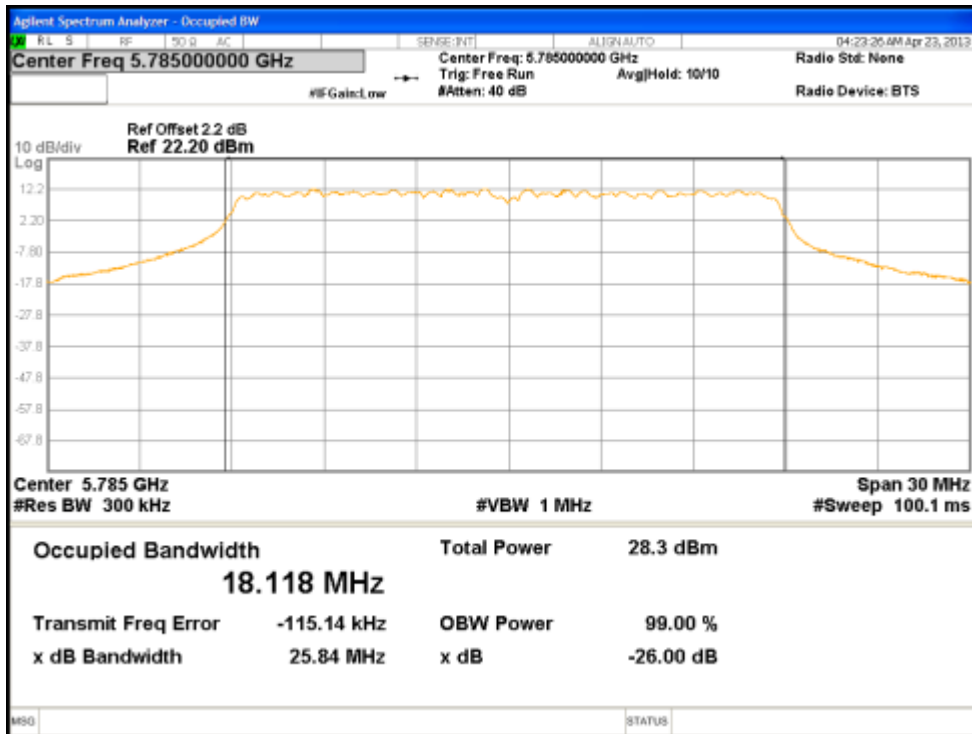

Figure 36: 99% Bandwidth at 5785 MHz, Chain 3

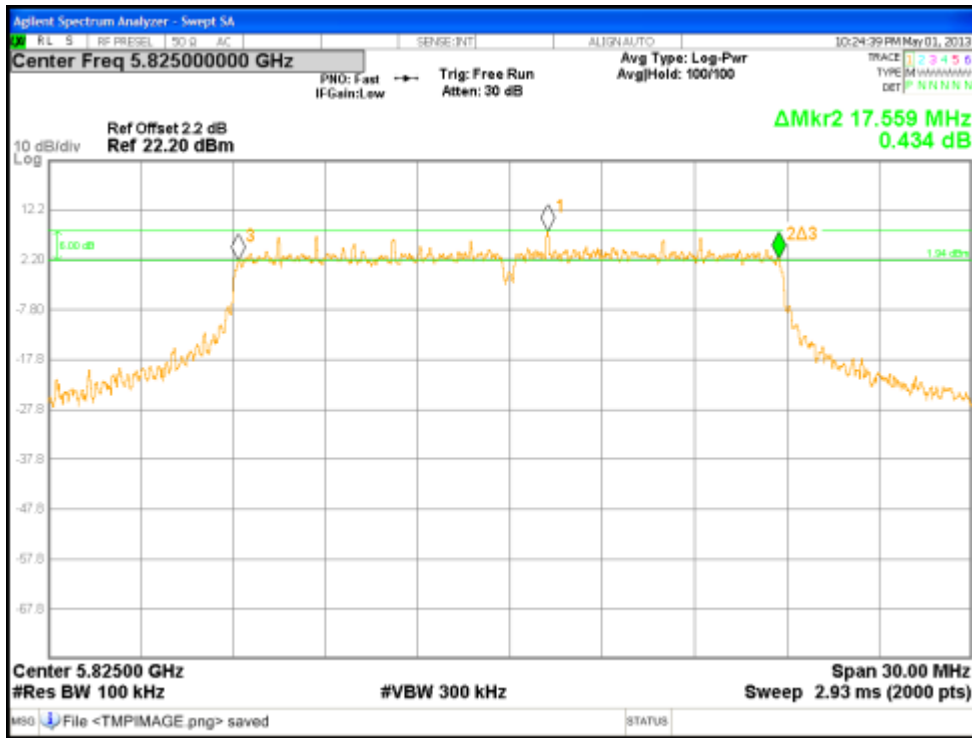

Figure 37: DTS Bandwidth at 5825 MHz, Chain 0

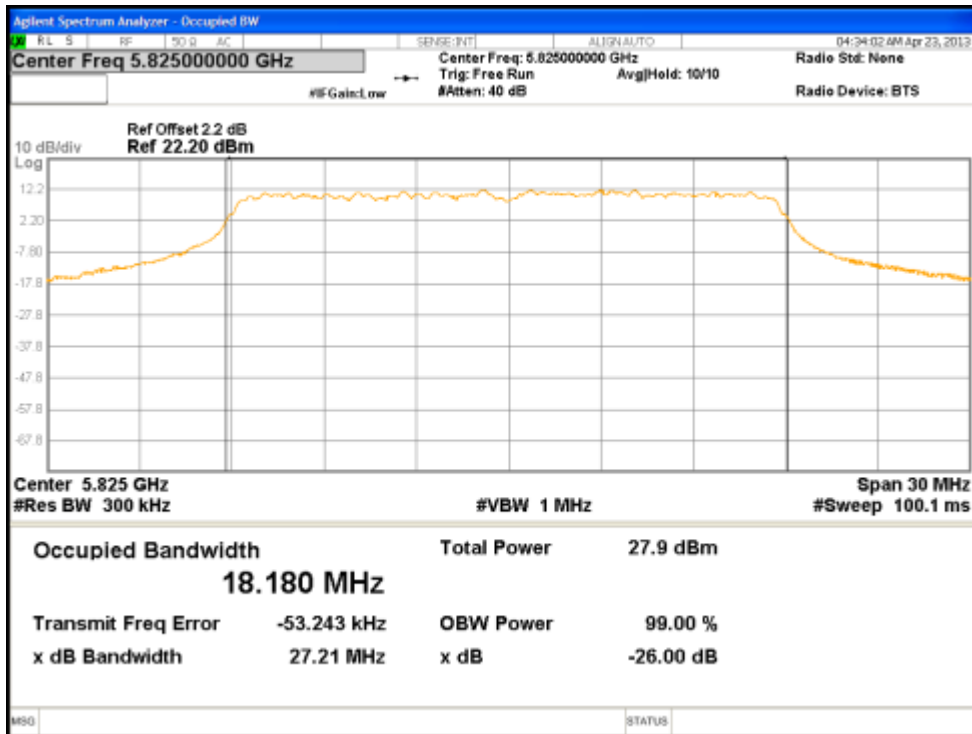

Figure 38: 99% Bandwidth at 5825 MHz, Chain 0

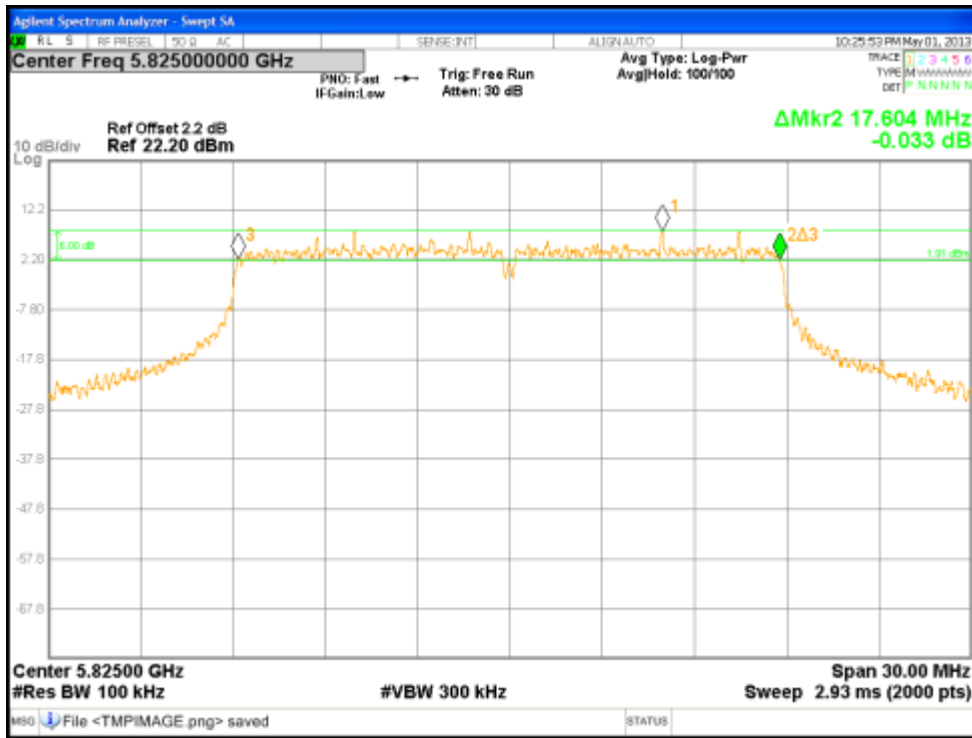

Figure 39: DTS Bandwidth at 5825 MHz, Chain 1

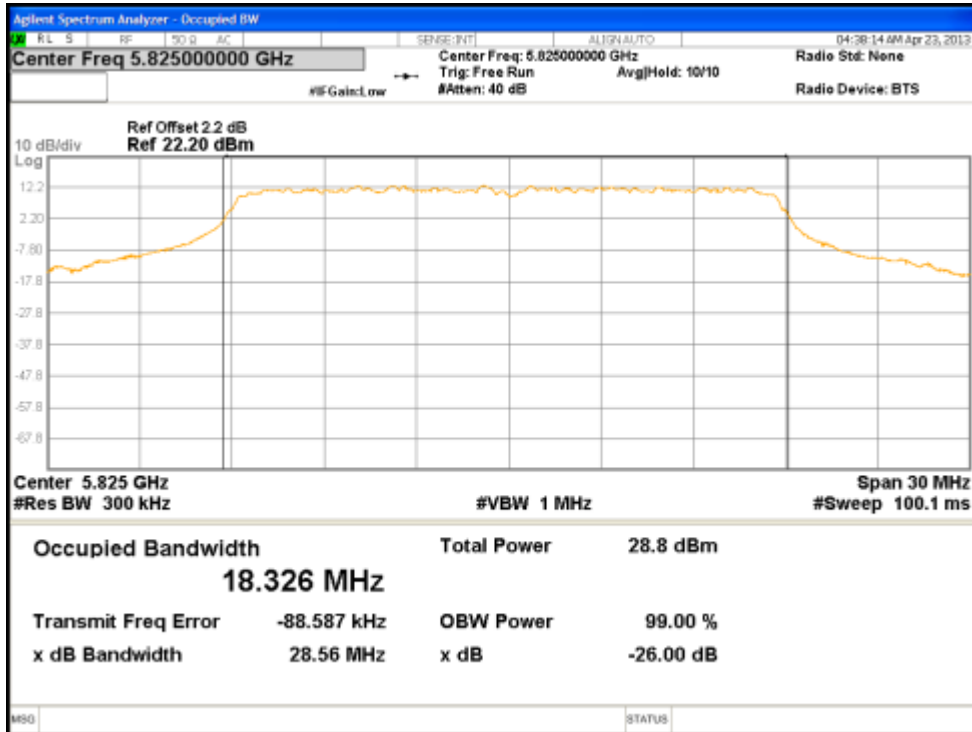

Figure 40: 99% Bandwidth at 5825 MHz, Chain 1

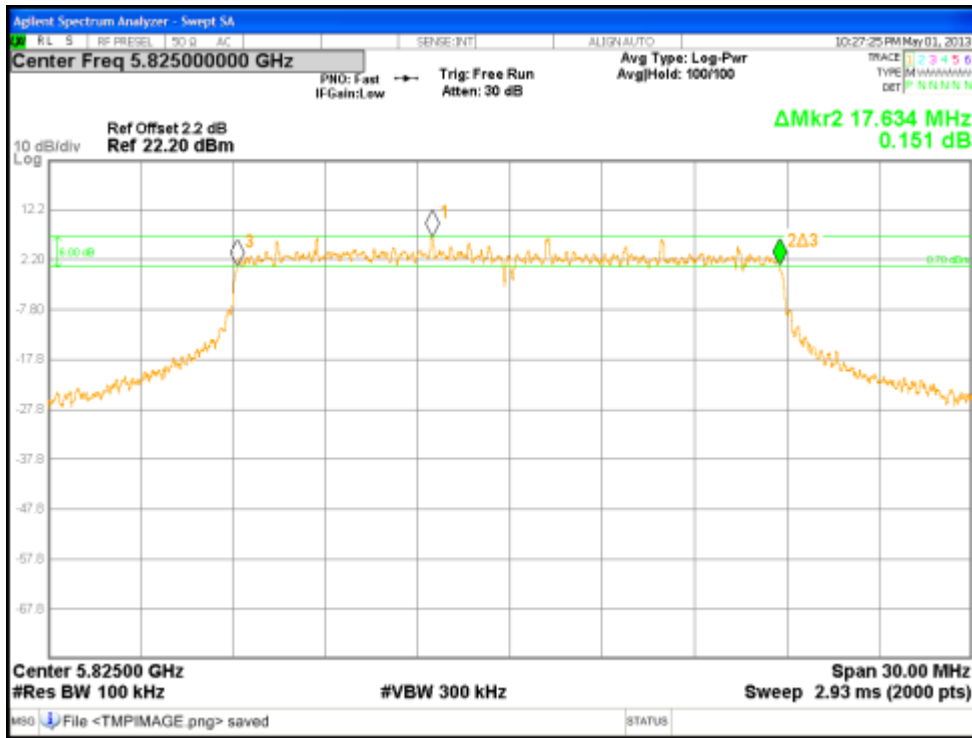

Figure 41: DTS Bandwidth at 5825 MHz, Chain 2

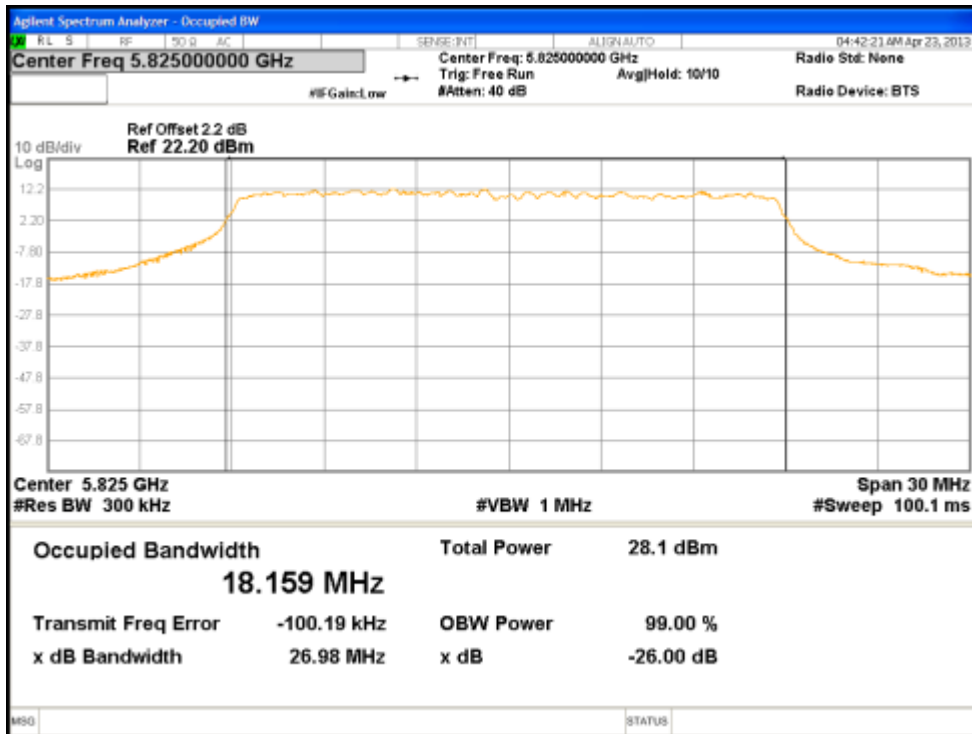

Figure 42: 99% Bandwidth at 5825 MHz, Chain 2

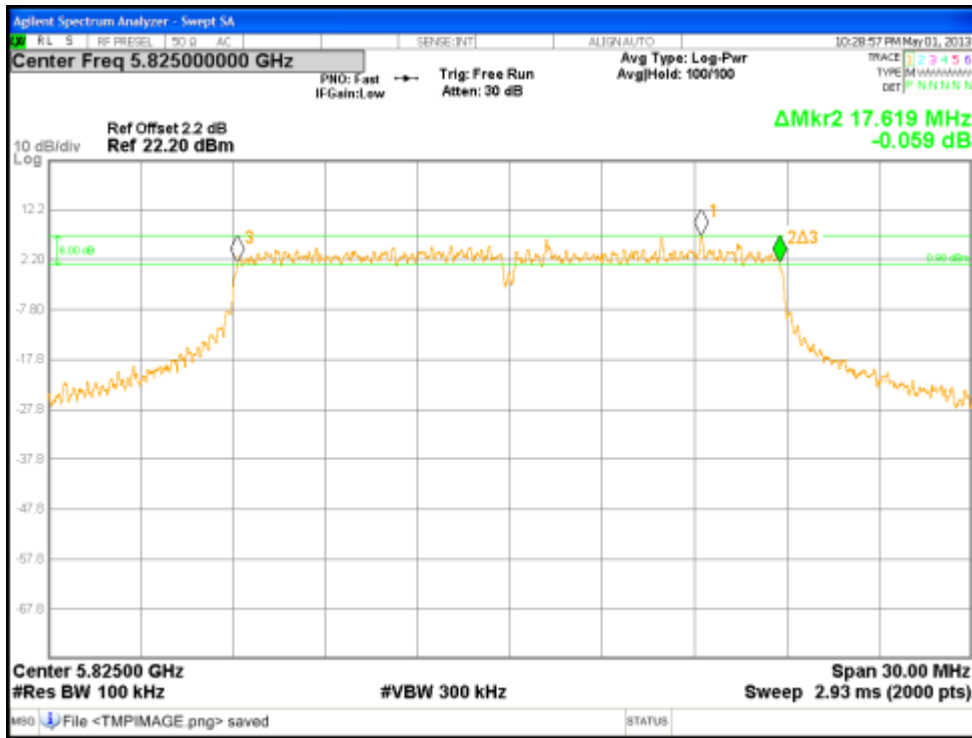

Figure 43: DTS Bandwidth at 5825 MHz, Chain 3

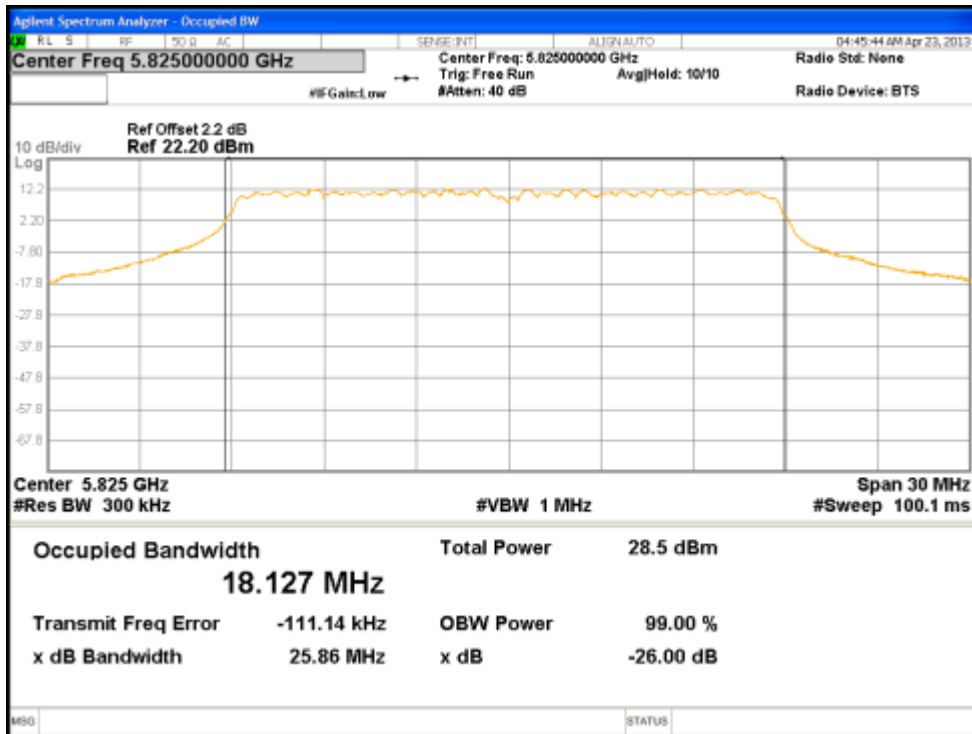

Figure 44: 99% Bandwidth at 5825 MHz, Chain 3

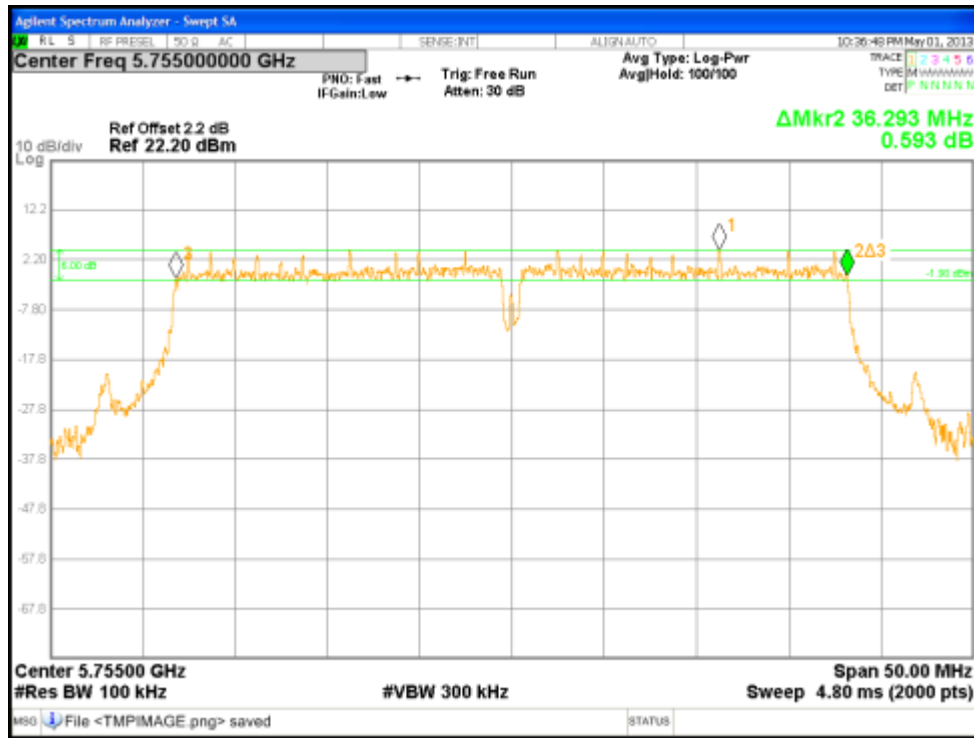

Figure 45: DTS Bandwidth at 5755 MHz, Chain 0

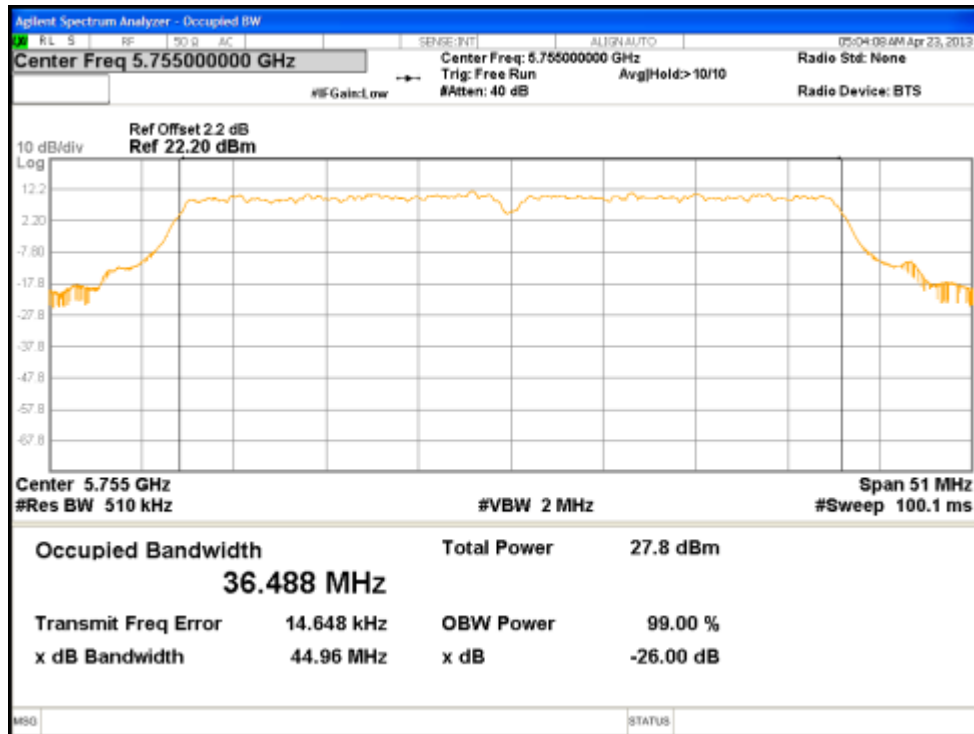

Figure 46: 99% Bandwidth at 5755 MHz, Chain 0



Figure 47: DTS Bandwidth at 5755 MHz, Chain 1

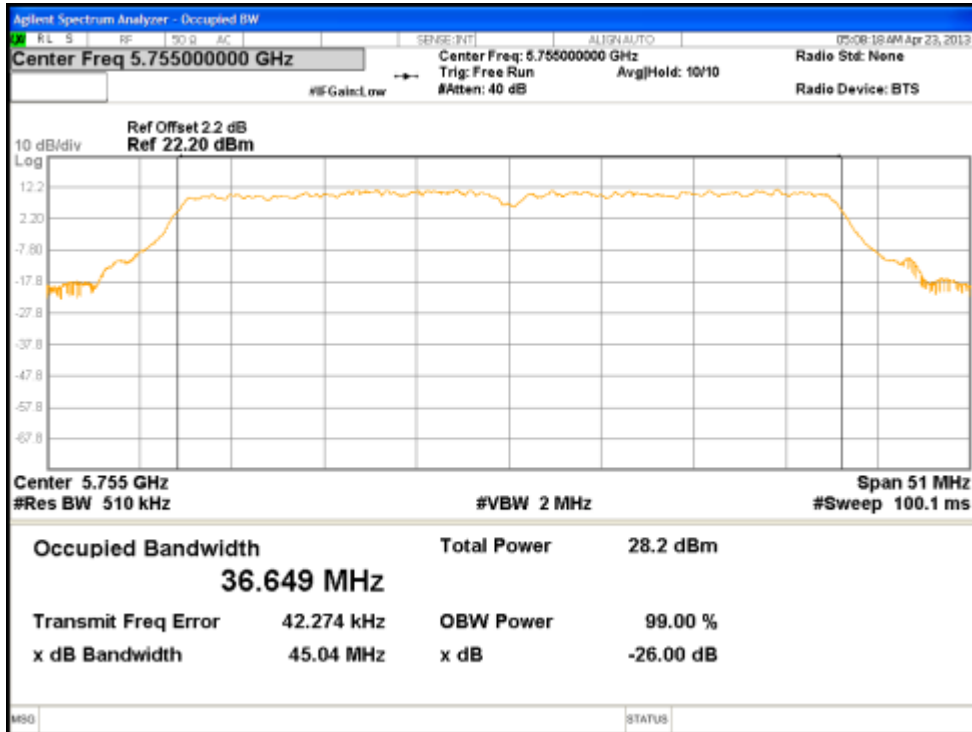

Figure 48: 99% Bandwidth at 5755 MHz, Chain 1

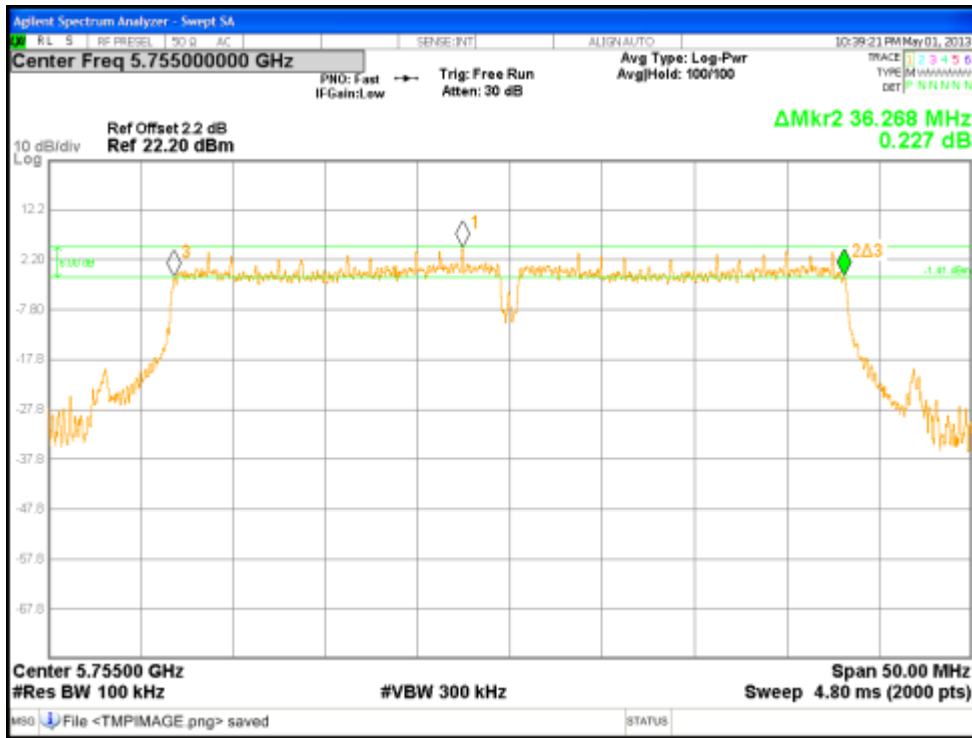

Figure 49: DTS Bandwidth at 5755 MHz, Chain 2

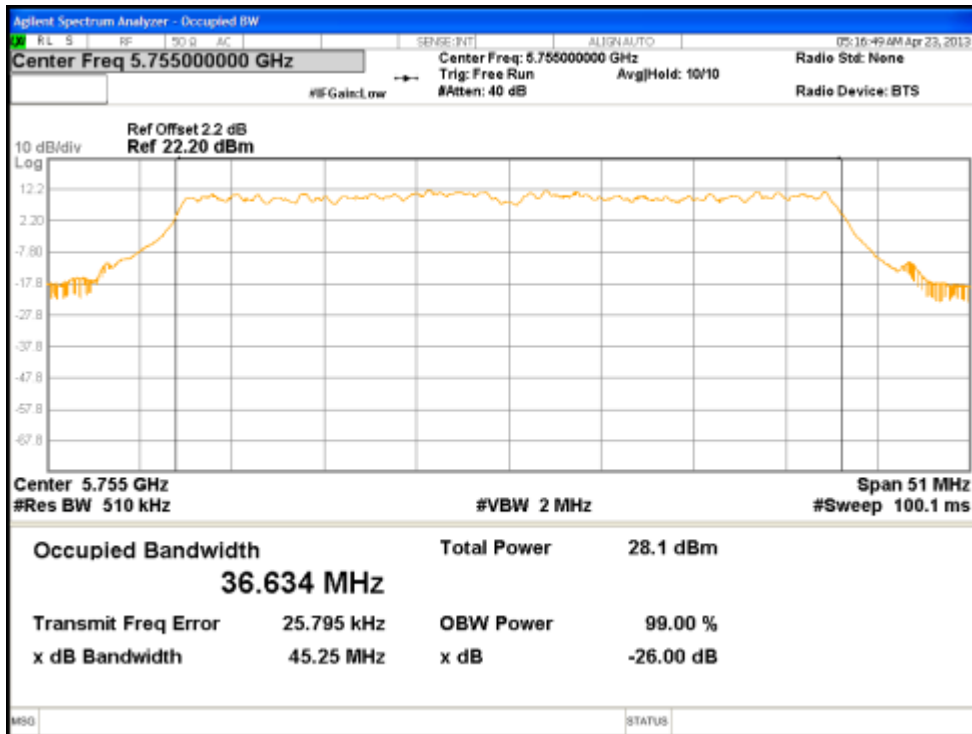

Figure 50: 99% Bandwidth at 5755 MHz, Chain 2



Figure 51: DTS Bandwidth at 5755 MHz, Chain 3

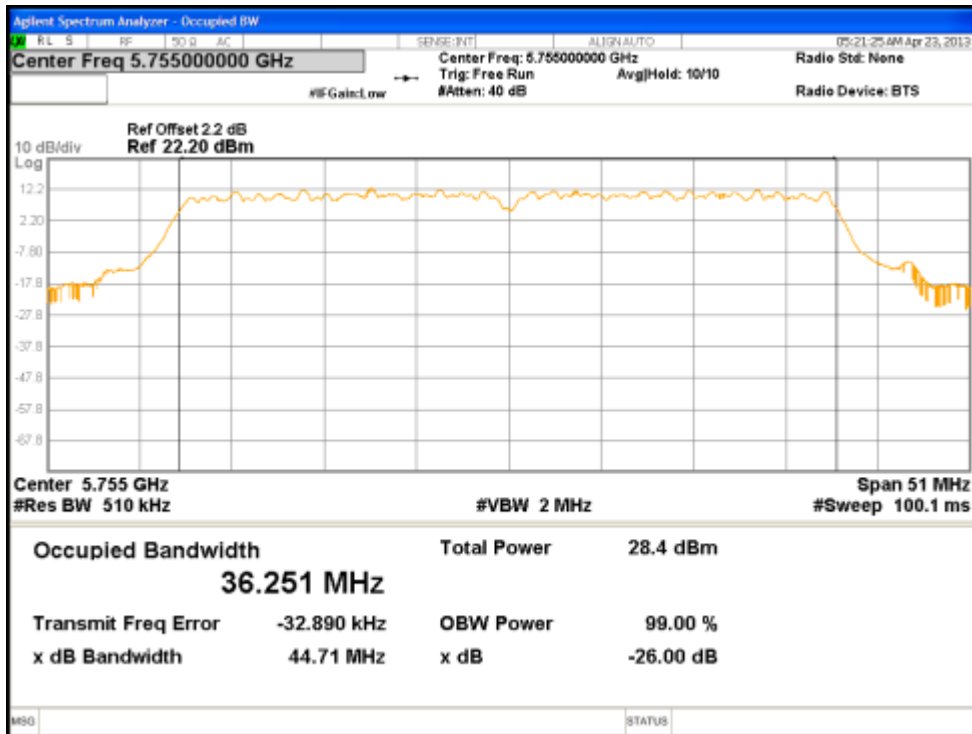

Figure 52: 99% Bandwidth at 5755 MHz, Chain 3

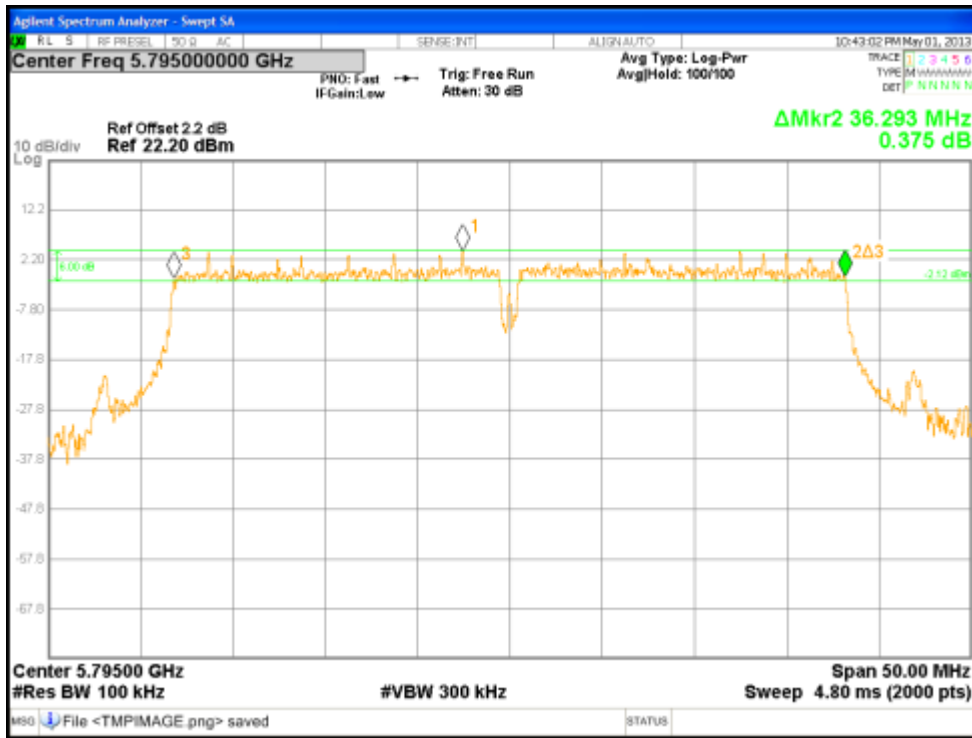

Figure 53: DTS Bandwidth at 5795 MHz, Chain 0

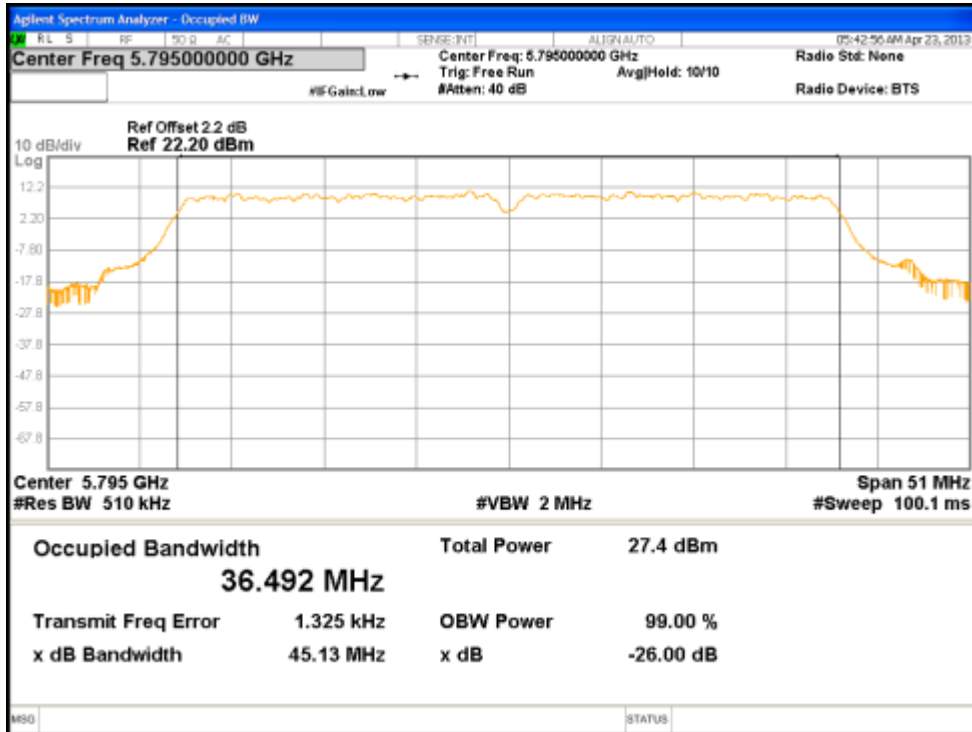

Figure 54: 99% Bandwidth at 5795 MHz, Chain 0

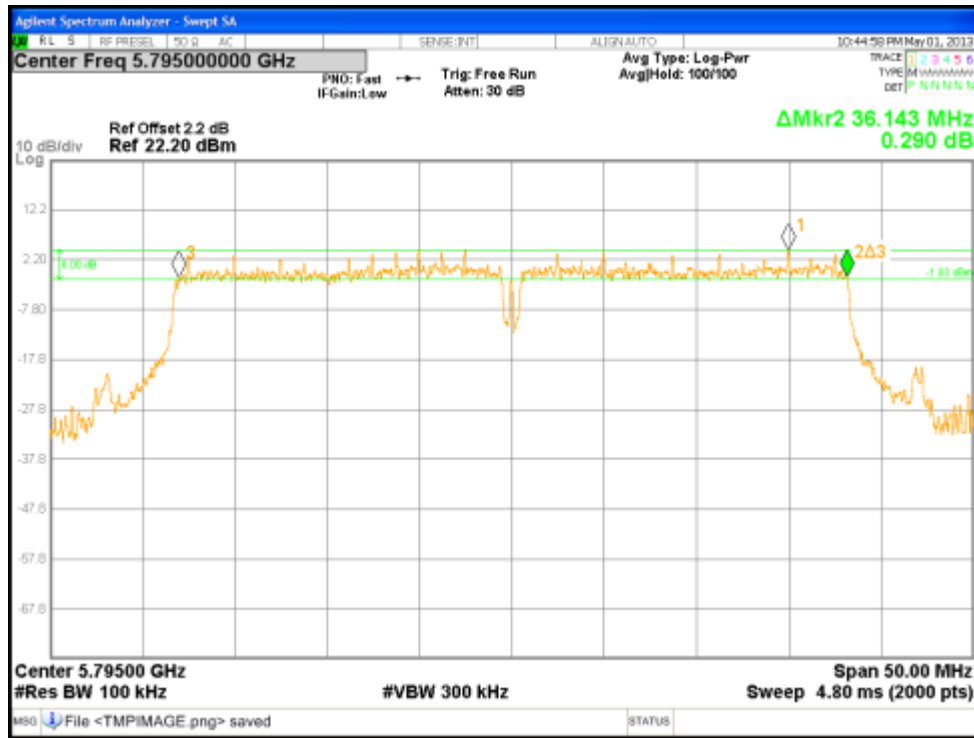

Figure 55: DTS Bandwidth at 5795 MHz, Chain 1

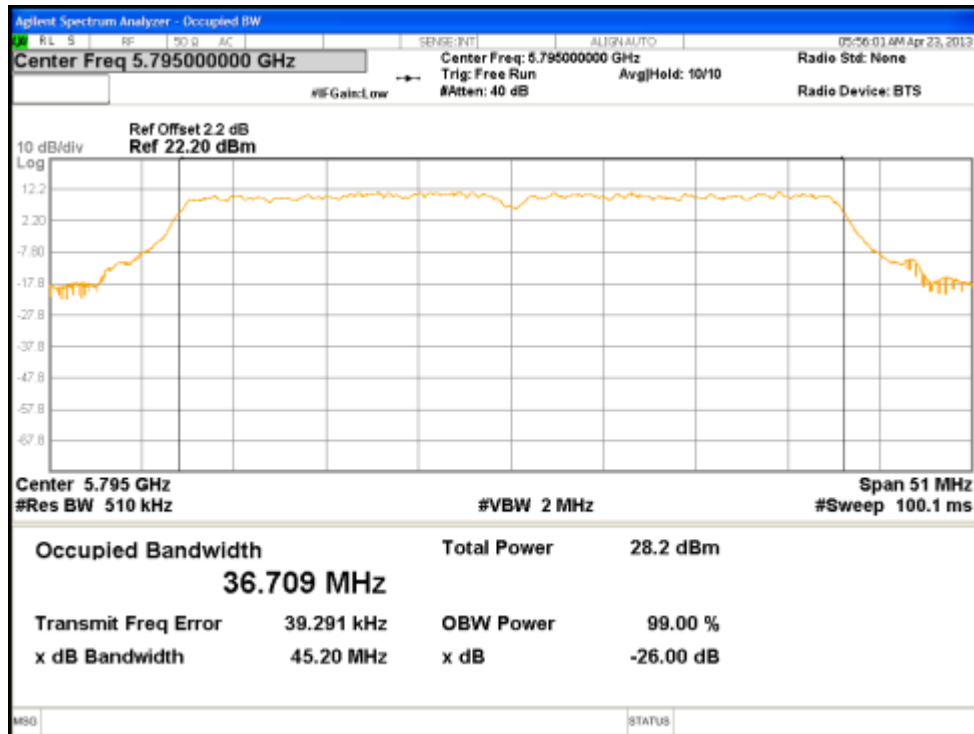

Figure 56: 99% Bandwidth at 5795 MHz, Chain 1

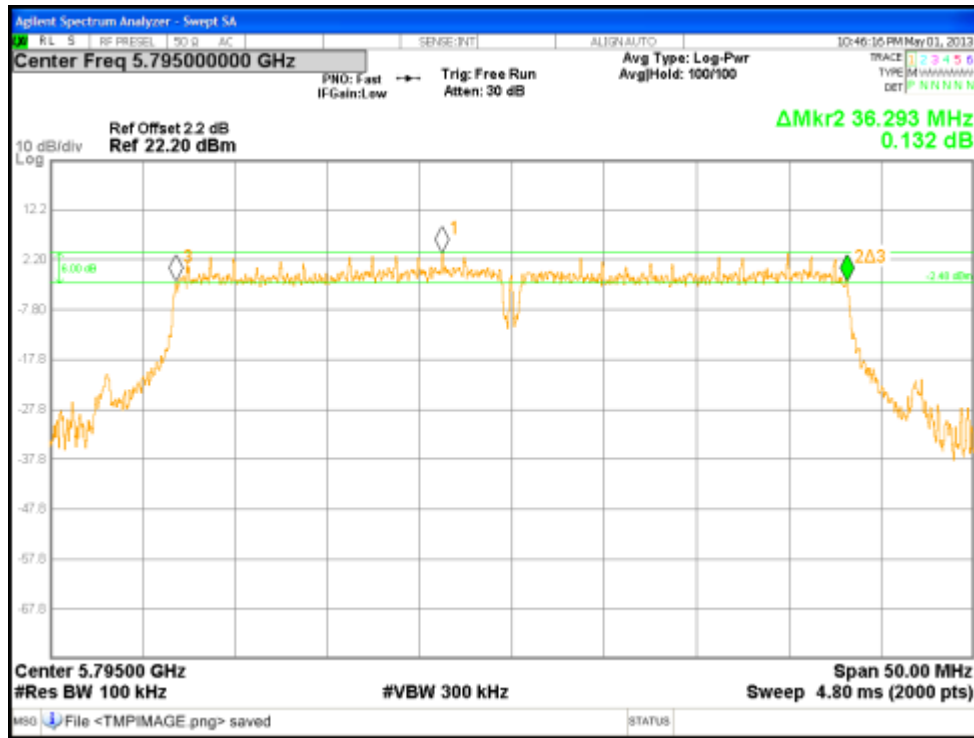

Figure 57: DTS Bandwidth at 5795 MHz, Chain 2

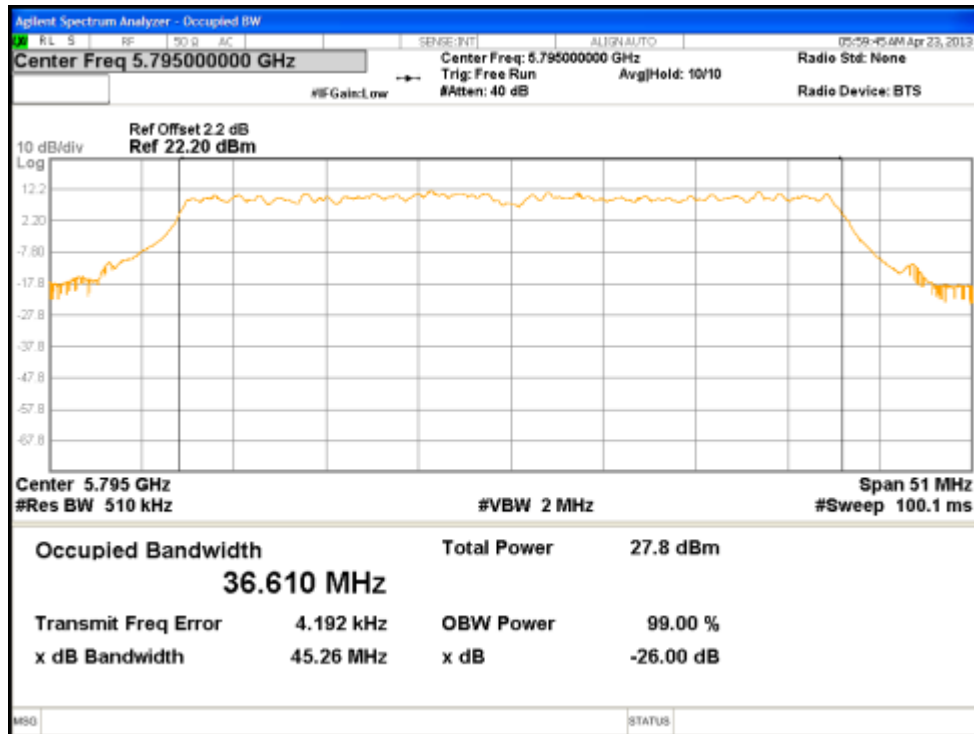

Figure 58: 99% Bandwidth at 5795 MHz, Chain 2

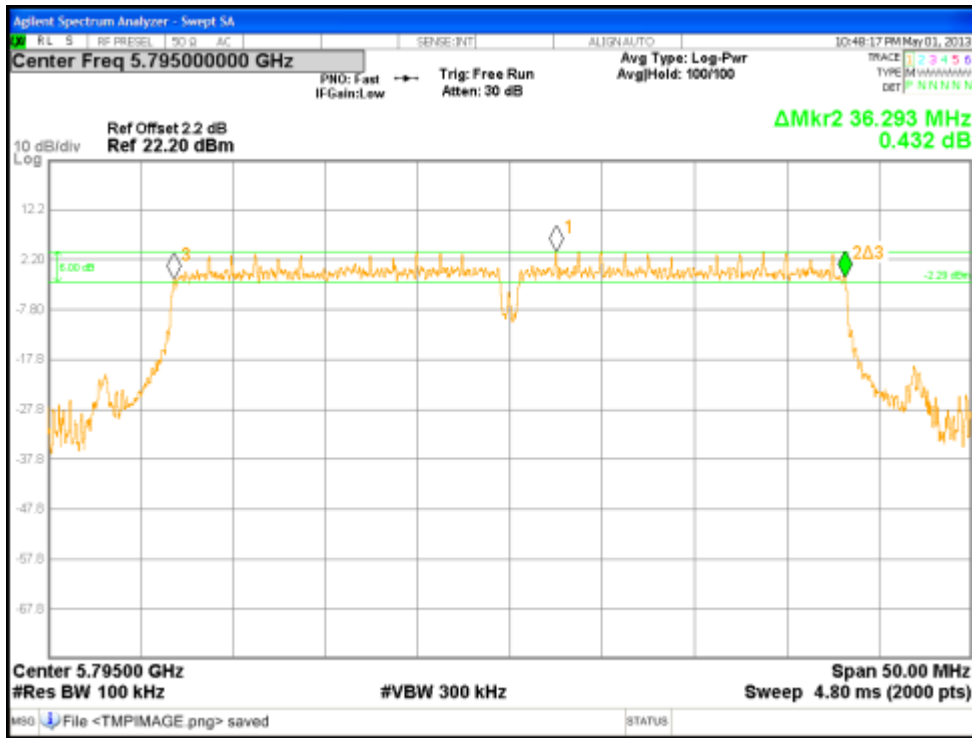

Figure 59: DTS Bandwidth at 5795 MHz, Chain 3

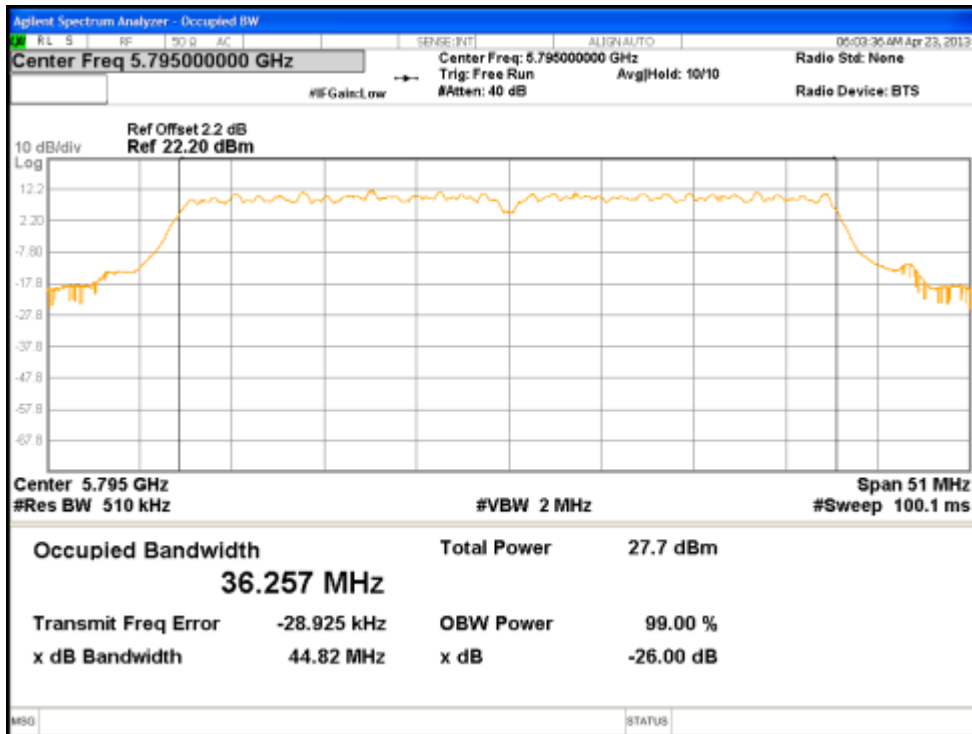

Figure 60: 99% Bandwidth at 5795 MHz, Chain 3

4.3 Unwanted Emissions into Non-Restricted Frequency Bands

The setup was identical to RF output power measurement. Intentional radiators operating under the alternative provisions to the general emission limits, must be designed to ensure that the 20 dB or 30 dB bandwidth of the emission, or whatever bandwidth may otherwise be specified in the specific rule section under which the equipment operates, is contained within the frequency band designated in the rule section under which the equipment is operated. The requirement to contain the designated bandwidth of the emission within the specified frequency band includes the effects from frequency sweeping, frequency hopping and other modulation techniques that may be employed as well as the frequency stability of the transmitter over expected variations in temperature and supply voltage. If the frequency stability is not specified in the regulations, it is recommended that the fundamental emission be kept within at least the central 80% of the permitted band in order to minimize the possibility of out-of-band operation.

Since the transmitter complies with the conducted power limits base on the use of RMS averaging per CFR47 Part 15.247(b)(3), any frequency outside the band of 5725MHz to 5850MHz, the power output level must be below 30db from the in-band transmitting signal; CFR 47 Part 15.215, 15.247(d) and RSS 210 A8.5

4.3.1 Test Method

The conducted method was used to measure the out-of-band emission requirement. The measurement was performed with modulation per CFR47 15.247(4)(d) 2010 and RSS 210 A8.5: 2010. This test was conducted on 3 channels of Sample in each mode on Sample, S/N 09130M000104. The worst sample result indicated below.

Test Setup:

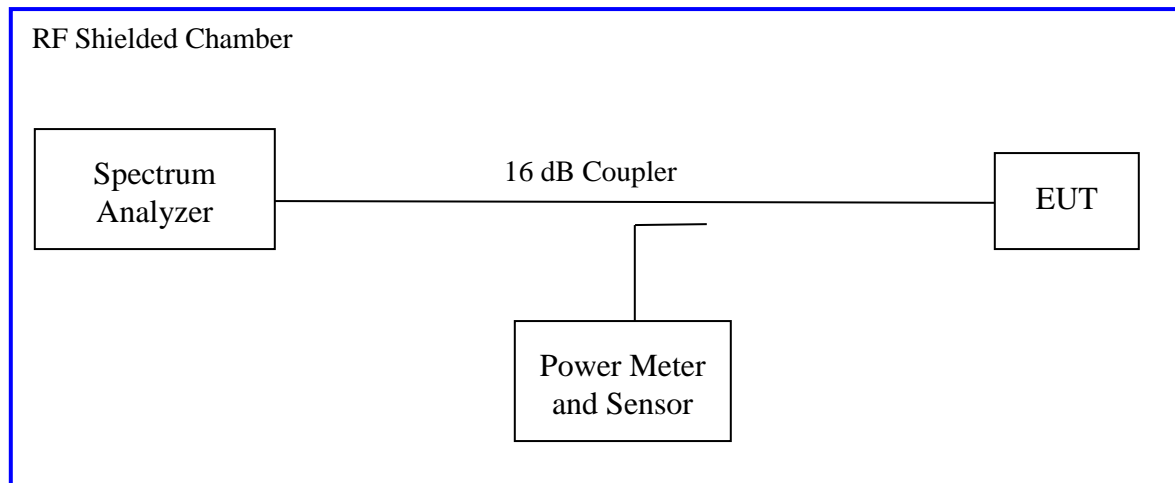

Measurement Procedure AVG2 of KDB 558074

4.3.2 Results

As originally tested, the EUT was found to be compliant to the requirements of the test standard(s).

Table 5: Emissions at the Band-Edge – Test Results

Test Conditions: Conducted Measurement, Normal Temperature and Voltage only					
Antenna Type: Integrated			Power Setting: See test plan		
Max. Directional Gain: + 8 dBi			Signal State: Modulated at 100%.		
Ambient Temp.: 23 °C			Relative Humidity: 30%		
Non-Restricted Frequency Band Emission					
Freq. (MHz)	Mode	Chain	Ref. Level (dBm)	Plots	Results
5745	6.5Mbps	0	-20.73	Fig. 61, 62, 63	Pass
5745	6.5Mbps	1	-19.99	Fig. 64, 65, 66	Pass
5745	6.5Mbps	2	-21.89	Fig. 67, 68, 69	Pass
5745	6.5Mbps	3	-21.29	Fig. 70, 71, 72,	Pass
5785	6.5Mbps	0	-20.97	Fig. 73, 74, 75	Pass
5785	6.5Mbps	1	-20.70	Fig. 76, 77, 78	Pass
5785	6.5Mbps	2	-21.56	Fig. 79, 80, 81	Pass
5785	6.5Mbps	3	-21.15	Fig. 82, 83, 84	Pass
5825	6.5Mbps	0	-21.00	Fig. 85, 86, 87	Pass
5825	6.5Mbps	1	-20.05	Fig. 88, 89, 90	Pass
5825	6.5Mbps	2	-21.17	Fig. 91, 92, 93	Pass
5825	6.5Mbps	3	-22.58	Fig. 94, 95, 96	Pass
5755	13.5 Mbps	0	-23.14	Fig. 97, 98	Pass
5755	13.5 Mbps	1	-22.72	Fig. 99, 100	Pass
5755	13.5 Mbps	2	-22.40	Fig. 101, 102	Pass
5755	13.5 Mbps	3	-23.13	Fig. 103, 104	Pass
5795	13.5 Mbps	0	-23.05	Fig. 105, 106	Pass

5795	13.5 Mbps	1	-22.58	Fig. 107, 108	Pass
5795	13.5 Mbps	2	-22.49	Fig. 109, 110	Pass
5795	13.5 Mbps	3	-22.92	Fig. 111, 112	Pass

Note: All out of band emissions are lower than the 30dB level.

The maximum out of band emission on each individual output put is at least 30 dB below the maximum in-band PSD on that output per KDB 662911.

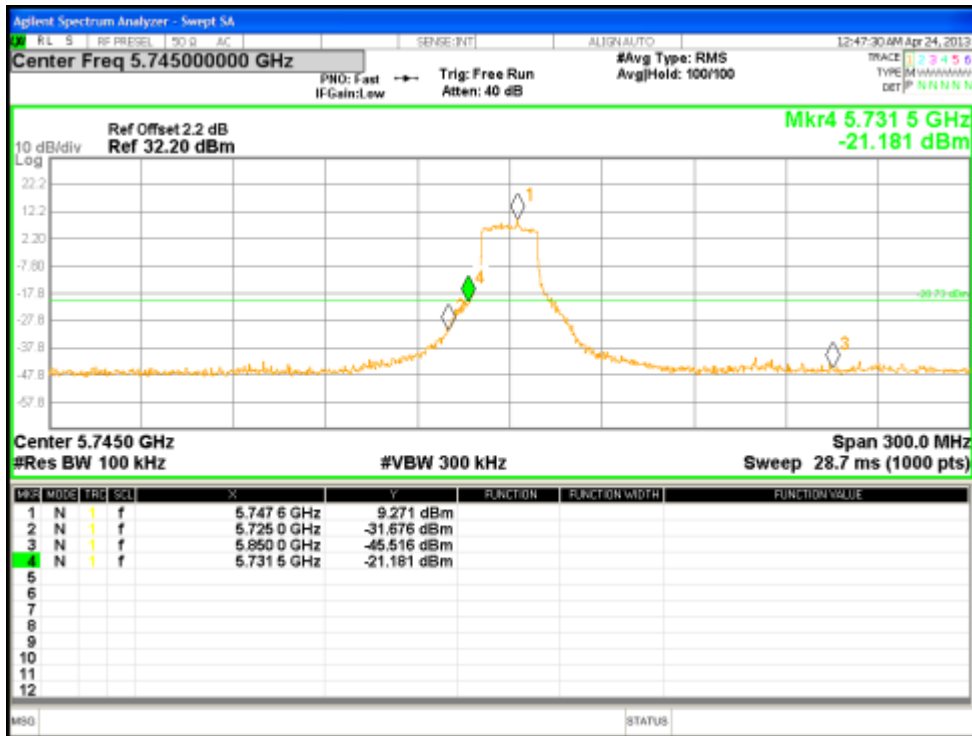

Figure 61: Reference Level for HT20 at 5745 MHz, Chain 0

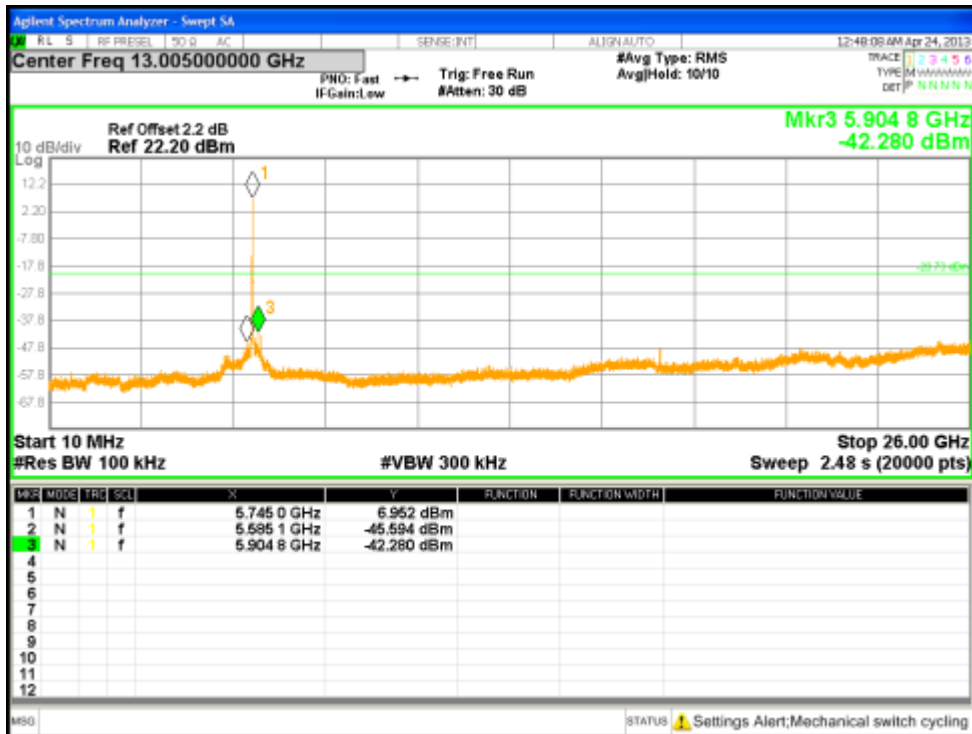
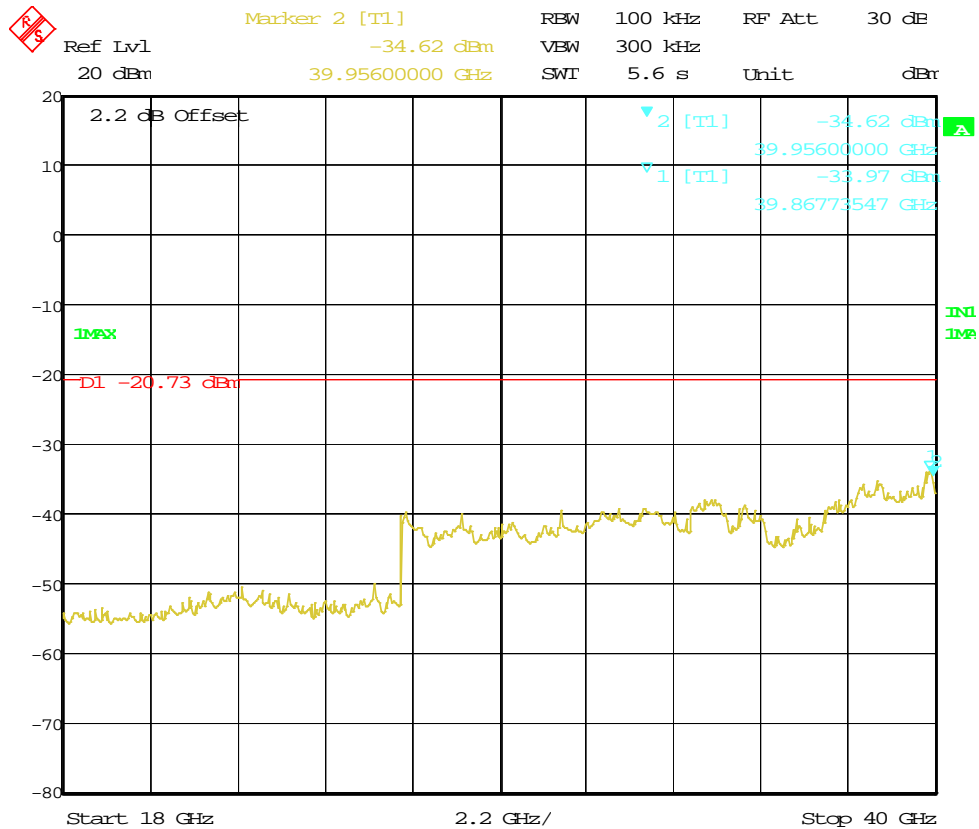

Figure 62: Out of Band Emission for HT20 at 5745 MHz, Chain 0



Date: 25.MAR.2013 15:05:28

Figure 63: Out of Band Emission for HT20 at 5745 MHz, Chain 0

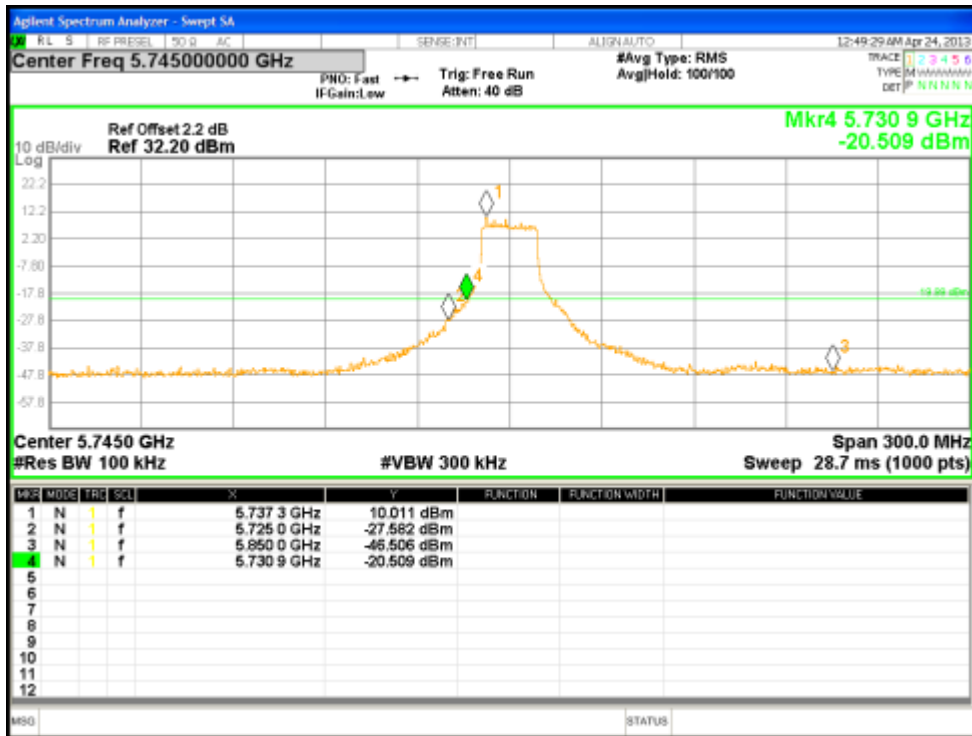

Figure 64: Reference Level for HT20 at 5745 MHz, Chain 1

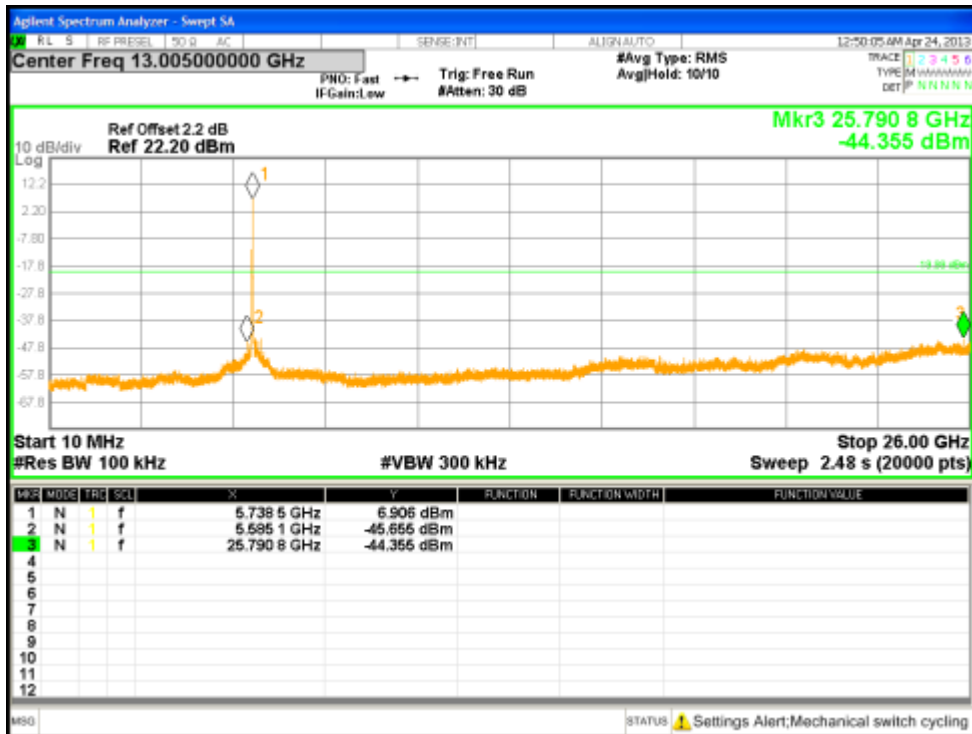
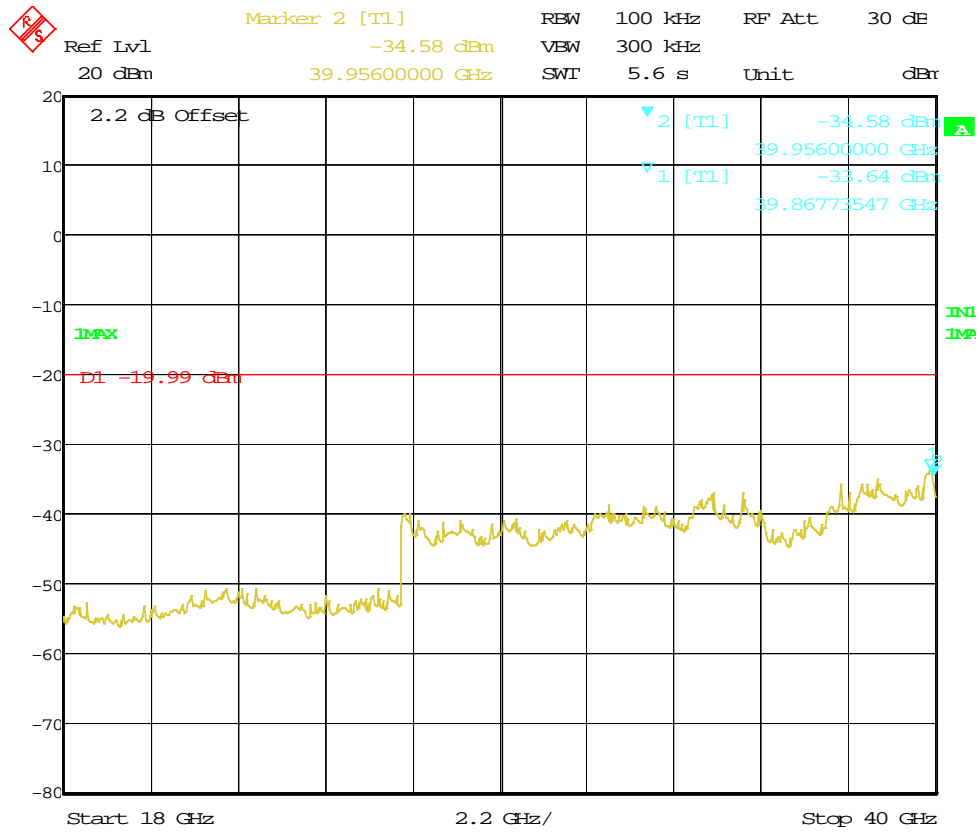

Figure 65: Out of Band Emission for HT20 at 5745 MHz, Chain 1



Date: 25.MAR.2013 15:06:20

Figure 66: Out of Band Emission for HT20 at 5745 MHz, Chain 1

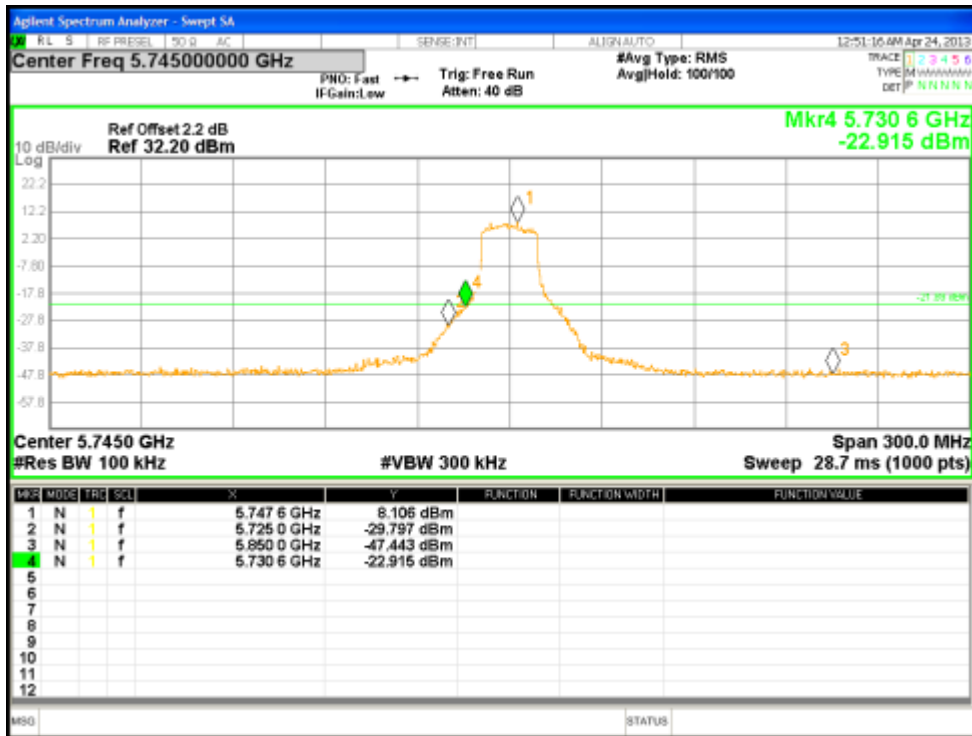

Figure 67: Reference Level for HT20 at 5745 MHz, Chain 2

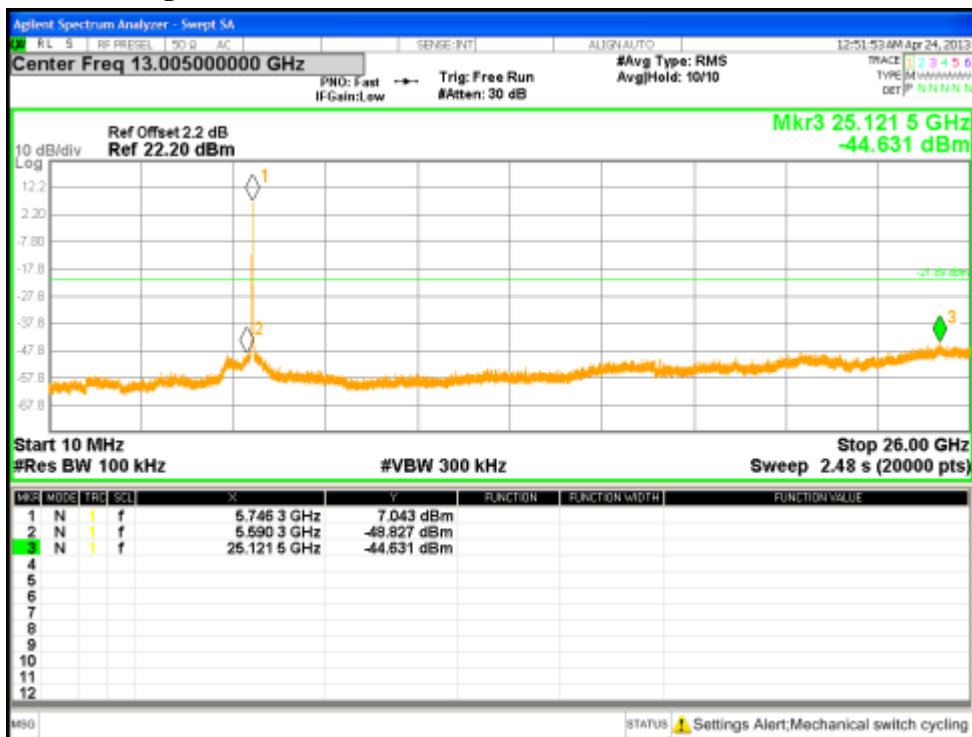
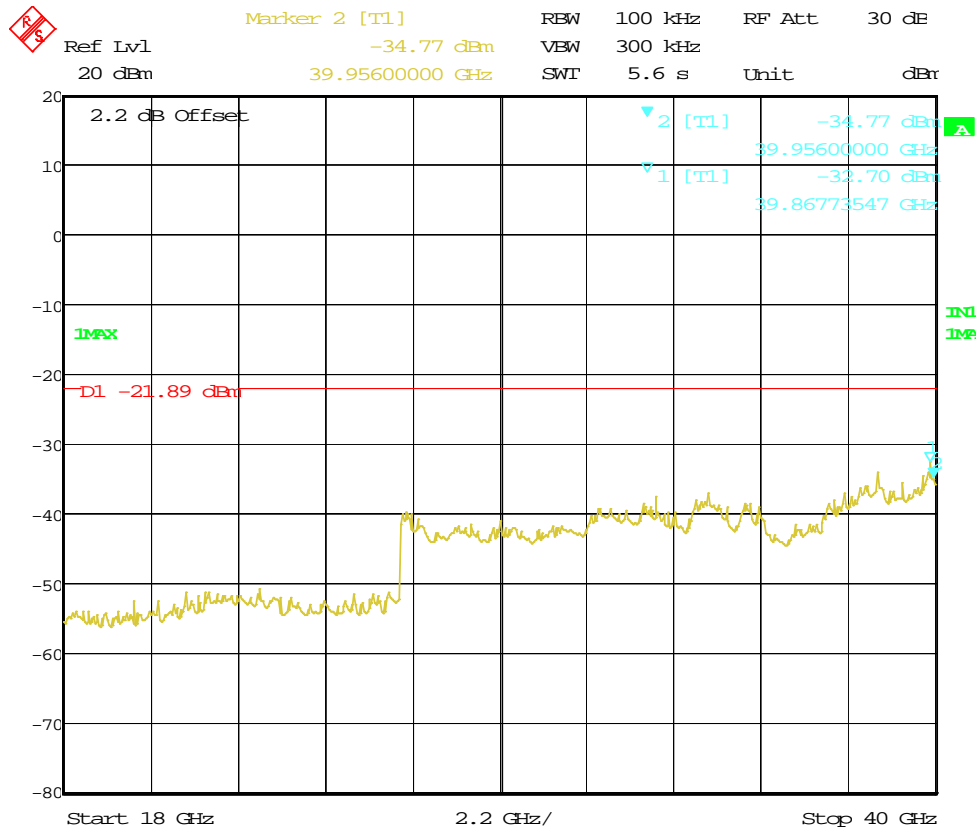

Figure 68: Out of Band Emission for HT20 at 5745 MHz, Chain 2



Date: 25.MAR.2013 15:07:18

Figure 69: Out of Band Emission for HT20 at 5745 MHz, Chain 2

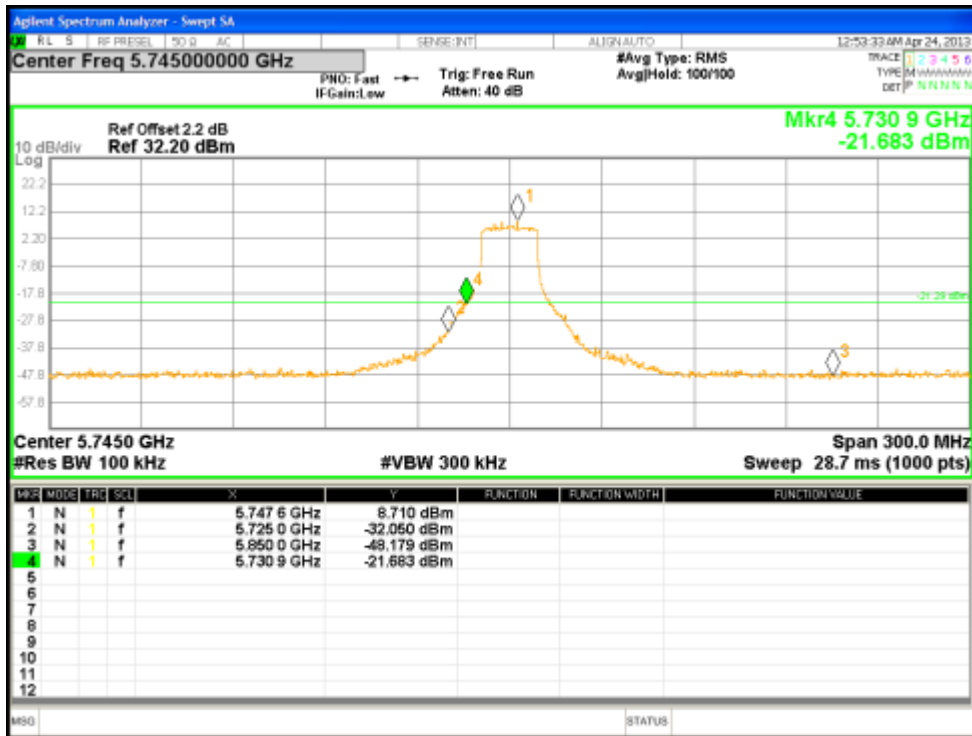

Figure 70: Reference Level for HT20 at 5745 MHz, Chain 3

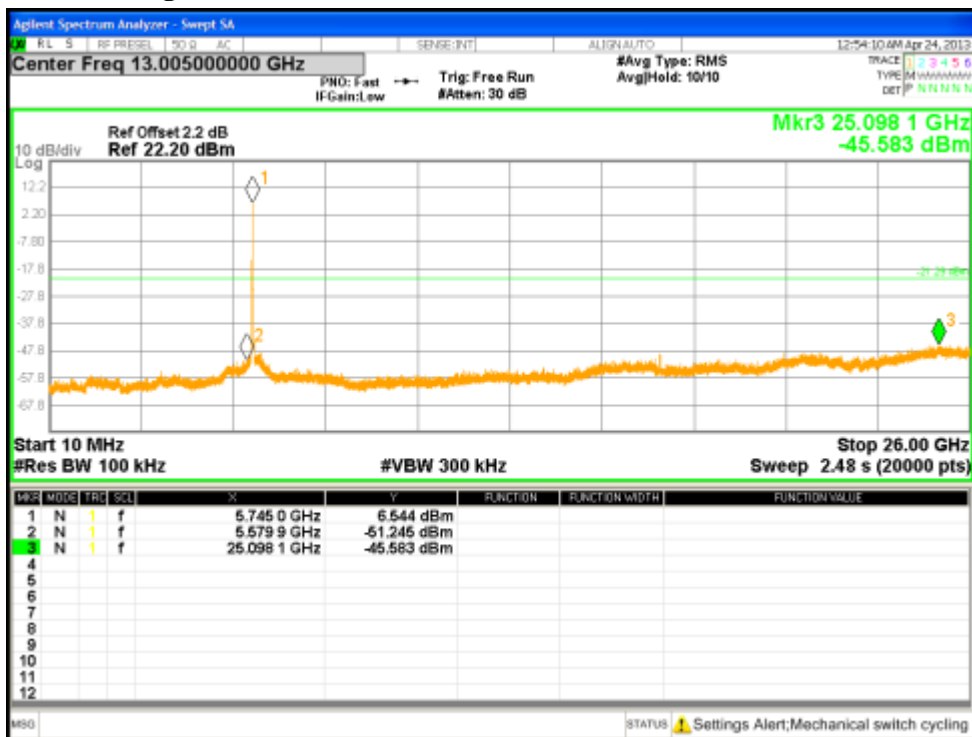
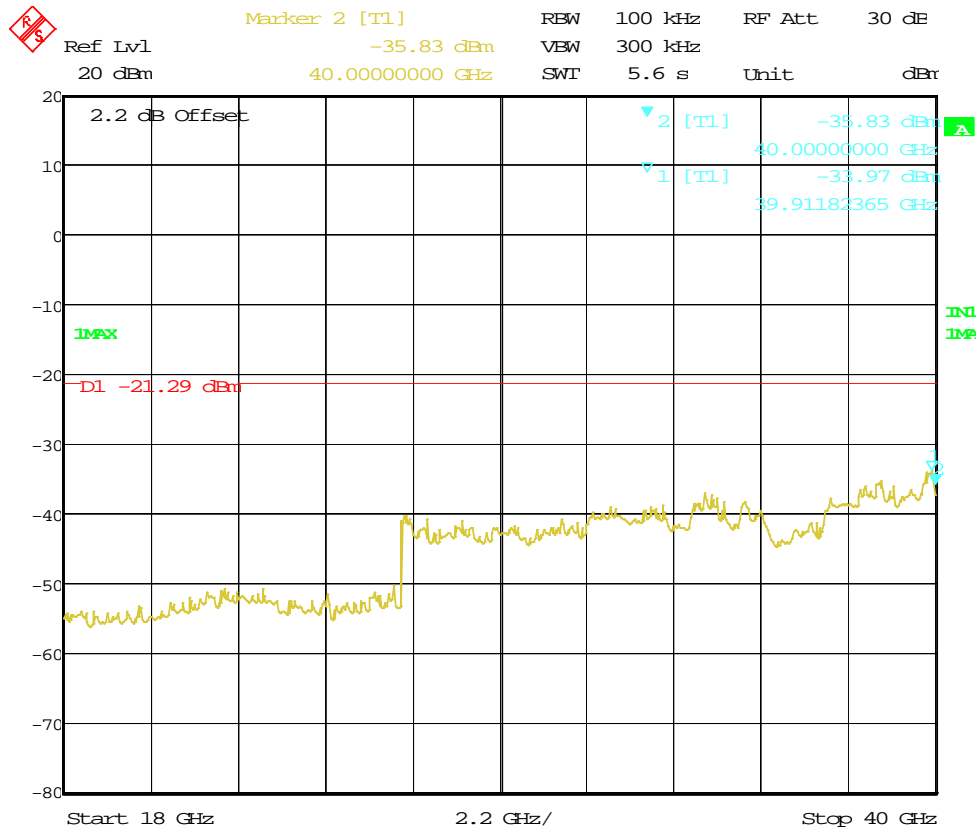

Figure 71: Out of Band Emission for HT20 at 5745 MHz, Chain 3



Date: 25.MAR.2013 15:08:44

Figure 72: Out of Band Emission for HT20 at 5745 MHz, Chain 3

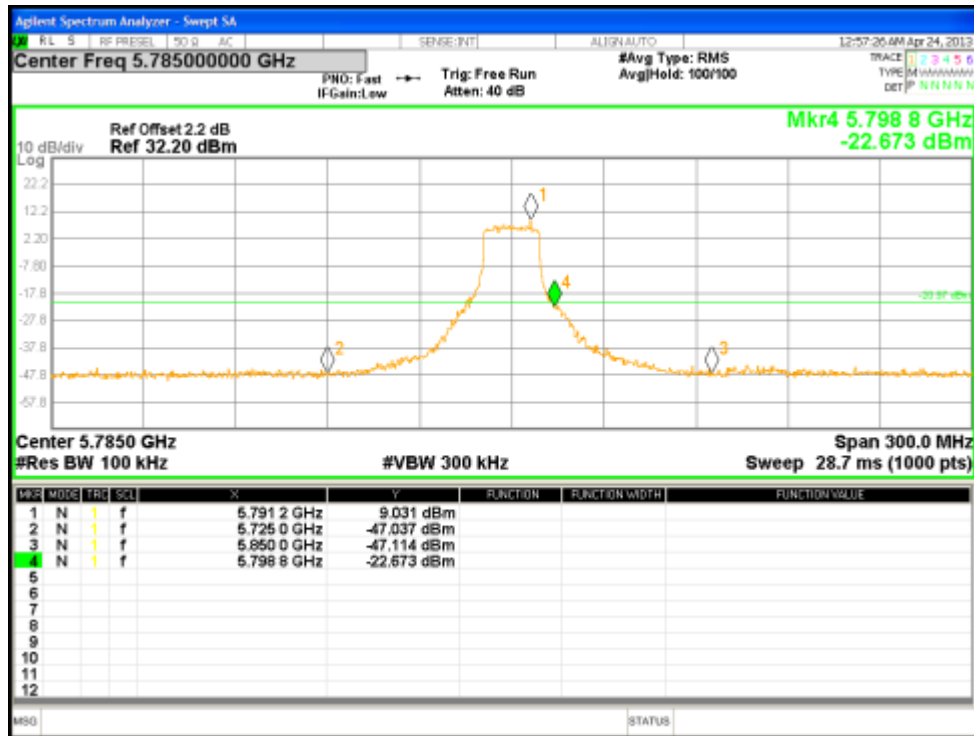

Figure 73: Reference Level for HT20 at 5785 MHz, Chain 0

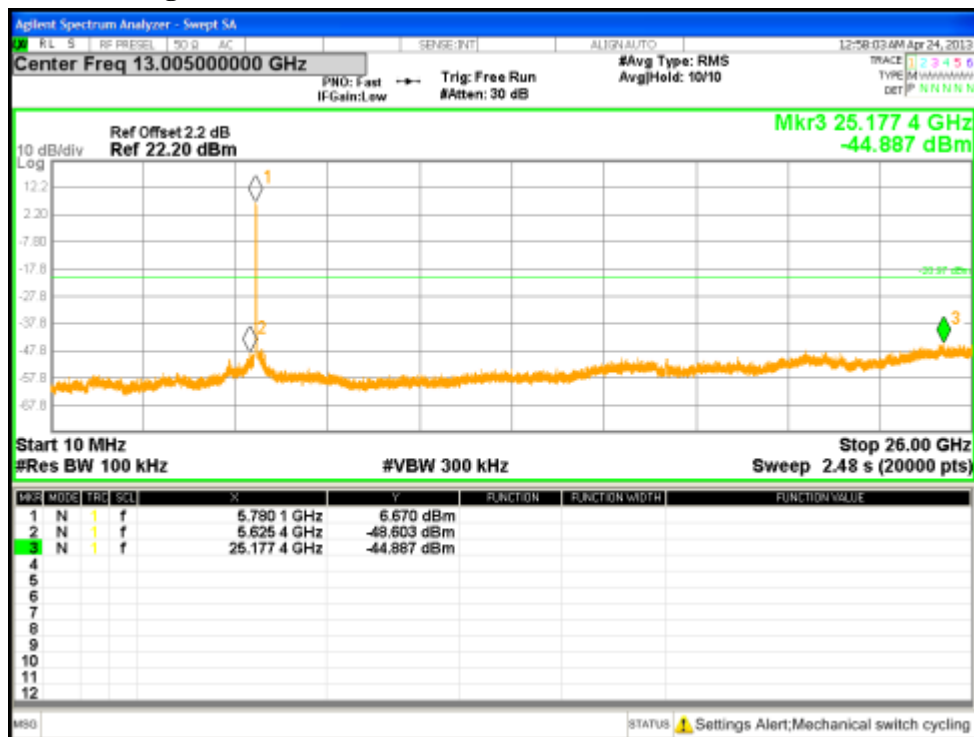
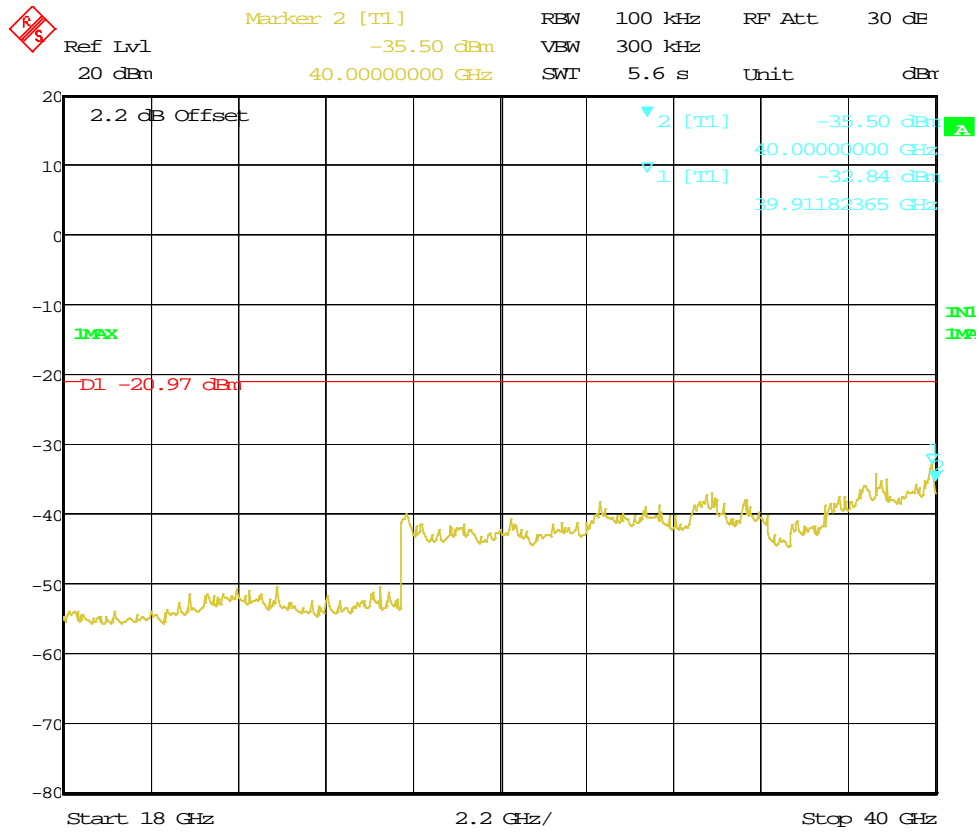

Figure 74: Out of Band Emission for HT20 at 5785 MHz, Chain 0



Date: 25.MAR.2013 15:11:48

Figure 75: Out of Band Emission for HT20 at 5785 MHz, Chain 0

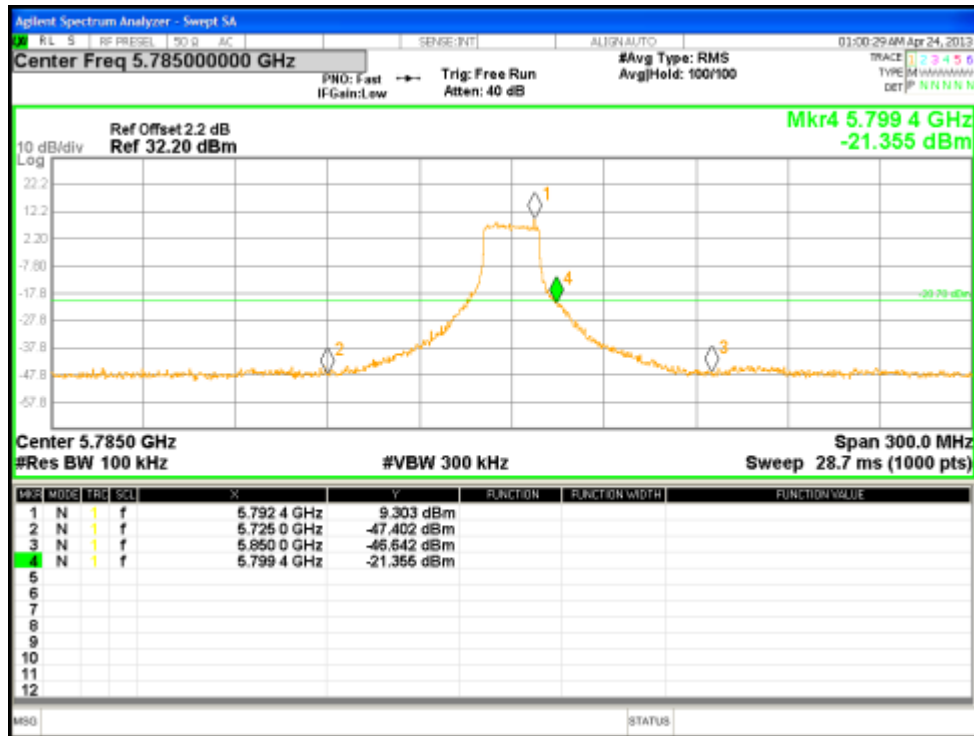

Figure 76: Reference Level for HT20 at 5785 MHz, Chain 1

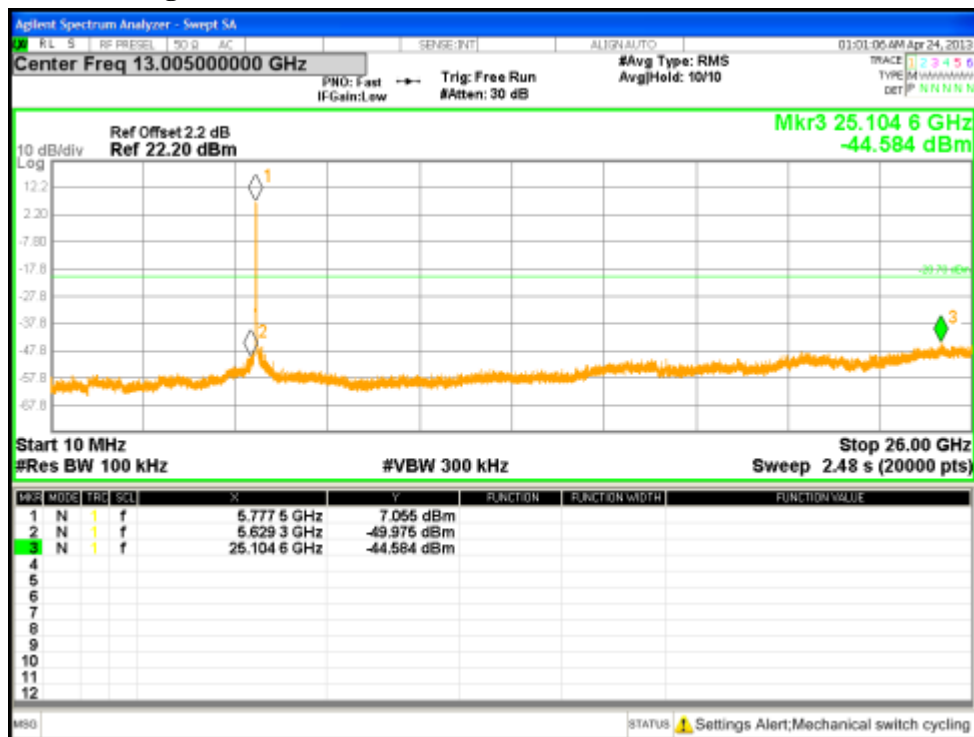
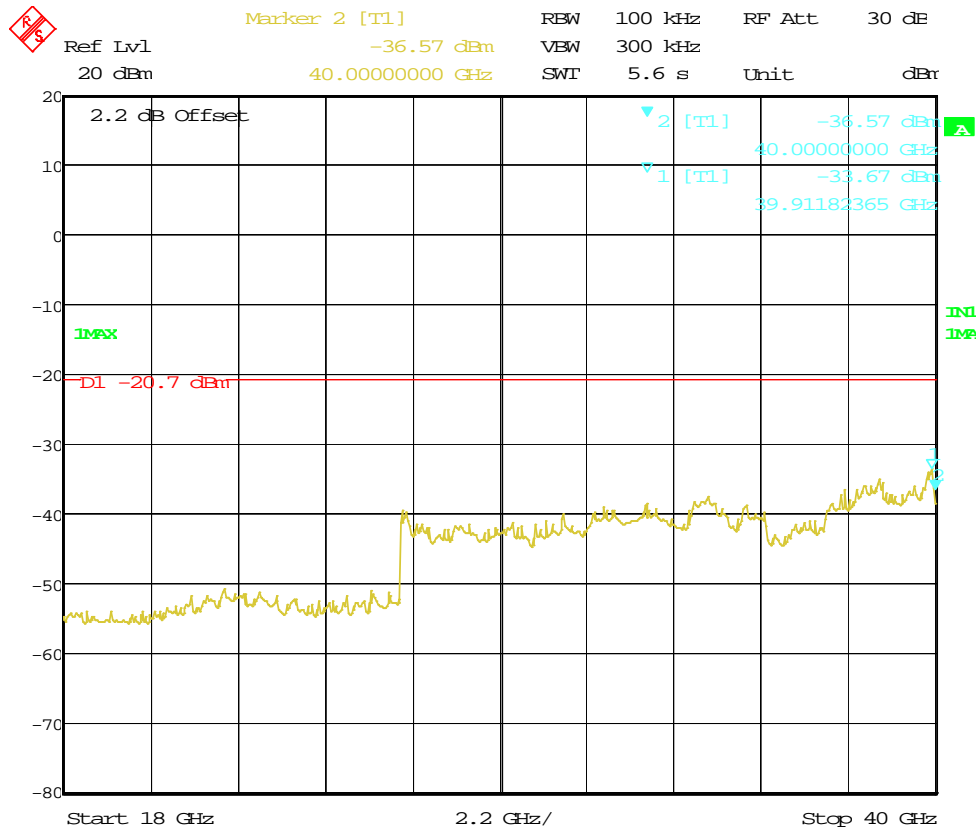

Figure 77: Out of Band Emission for HT20 at 5785 MHz, Chain 1



Date: 25.MAR.2013 15:13:31

Figure 78: Out of Band Emission for HT20 at 5785 MHz, Chain 1

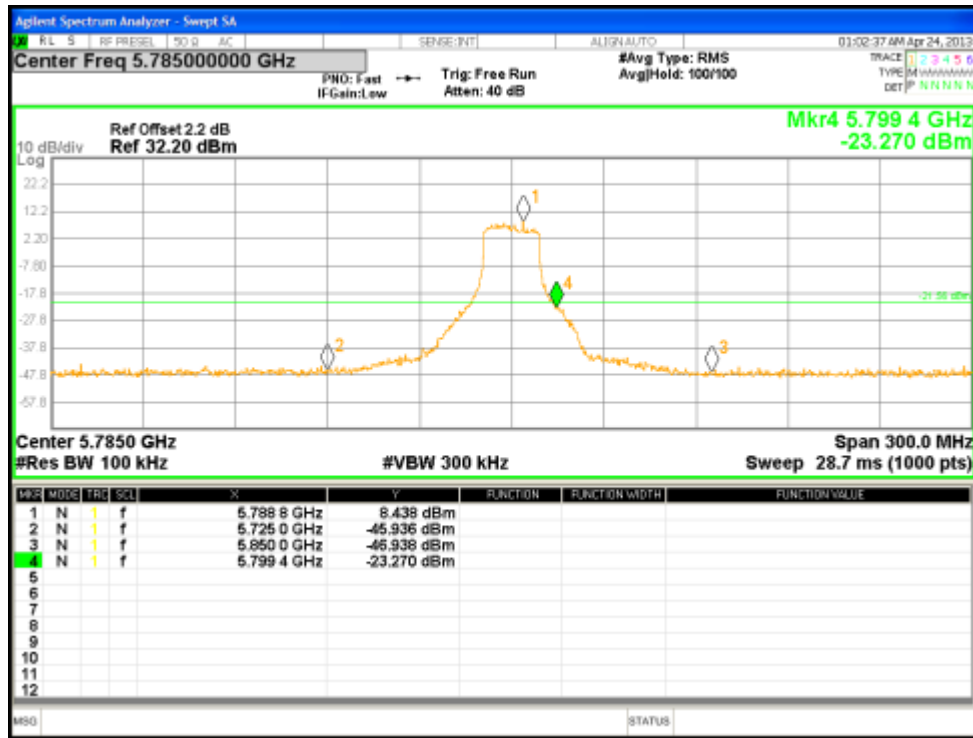

Figure 79: Reference Level for HT20 at 5785 MHz, Chain 2

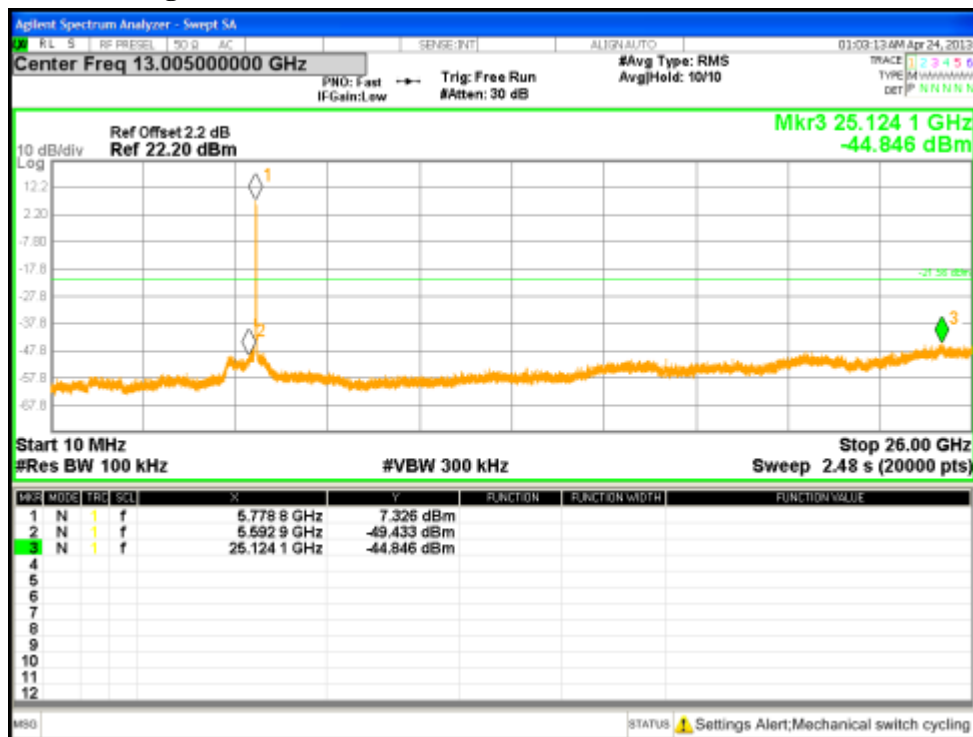
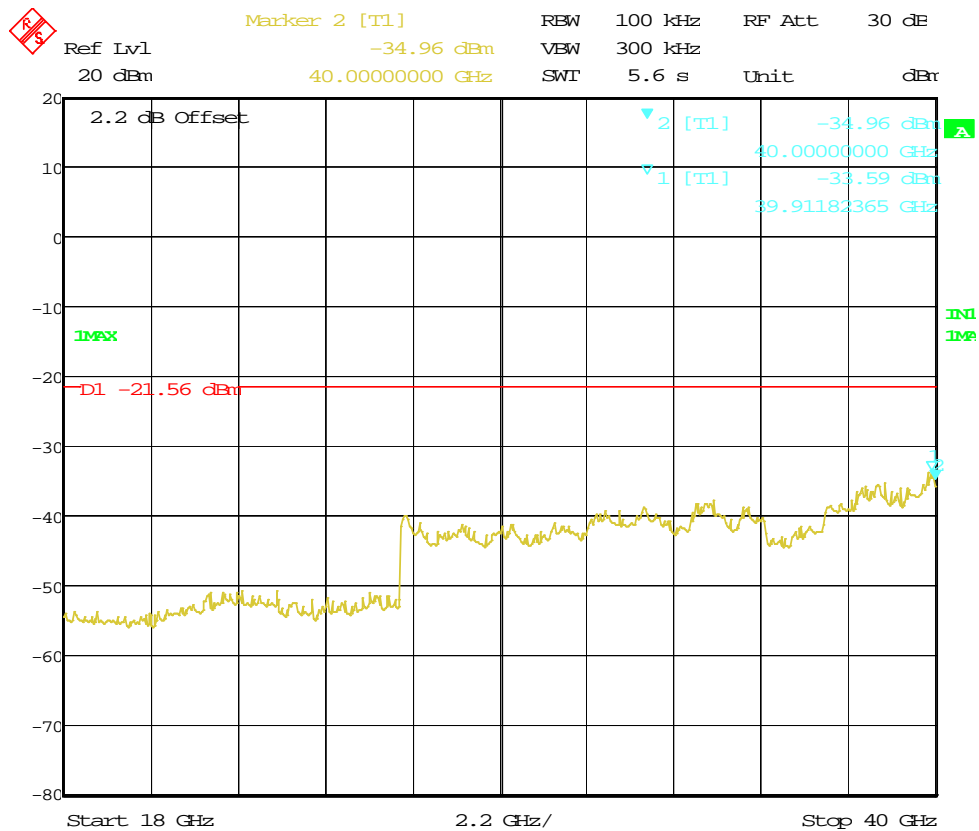

Figure 80: Out of Band Emission for HT20 at 5785 MHz, Chain 2



Date: 25.MAR.2013 15:14:22

Figure 81: Out of Band Emission for HT20 at 5785 MHz, Chain 2

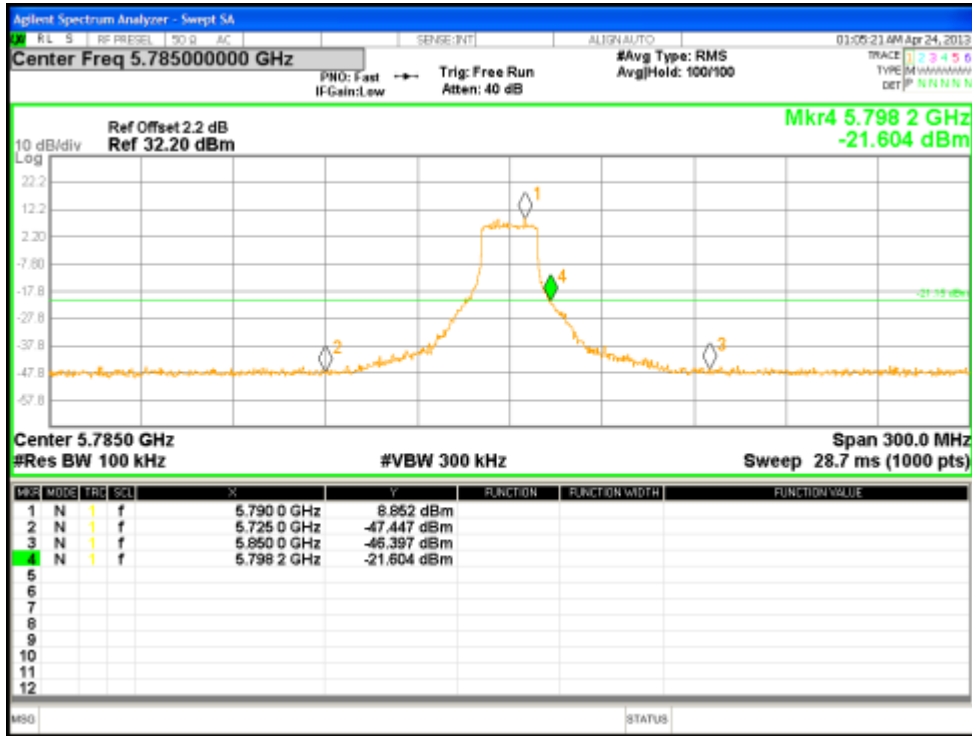

Figure 82: Reference Level for HT20 at 5785 MHz, Chain 3

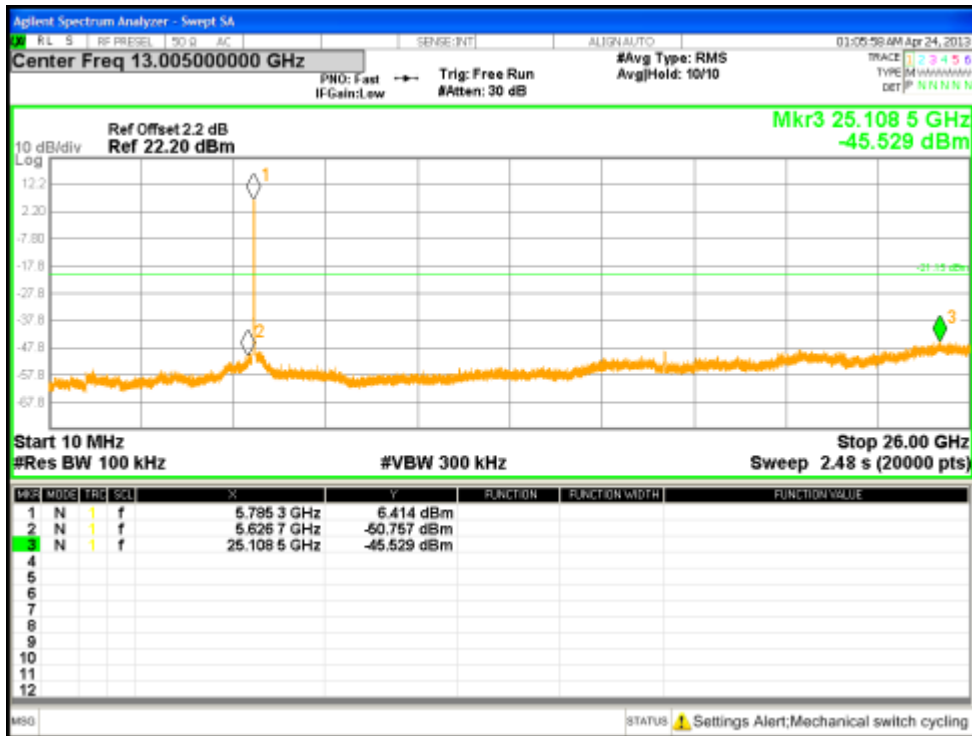
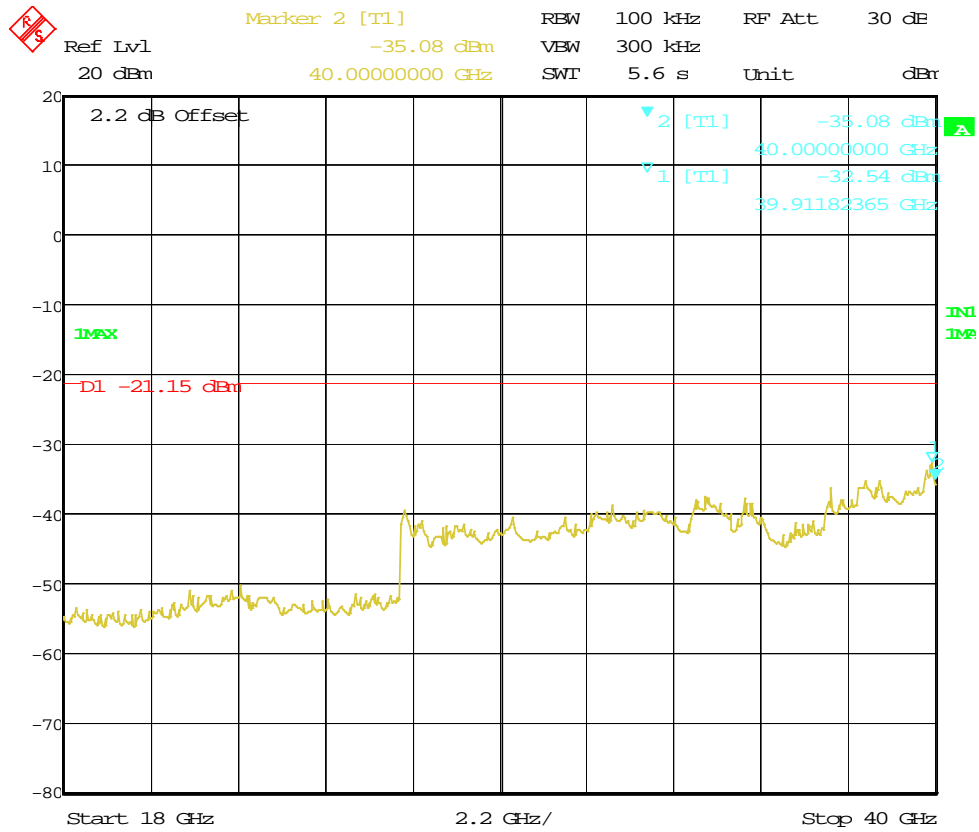

Figure 83: Out of Band Emission for HT20 at 5785 MHz, Chain 3



Date: 25.MAR.2013 15:15:19

Figure 84: Out of Band Emission for HT20 at 5785 MHz, Chain 3

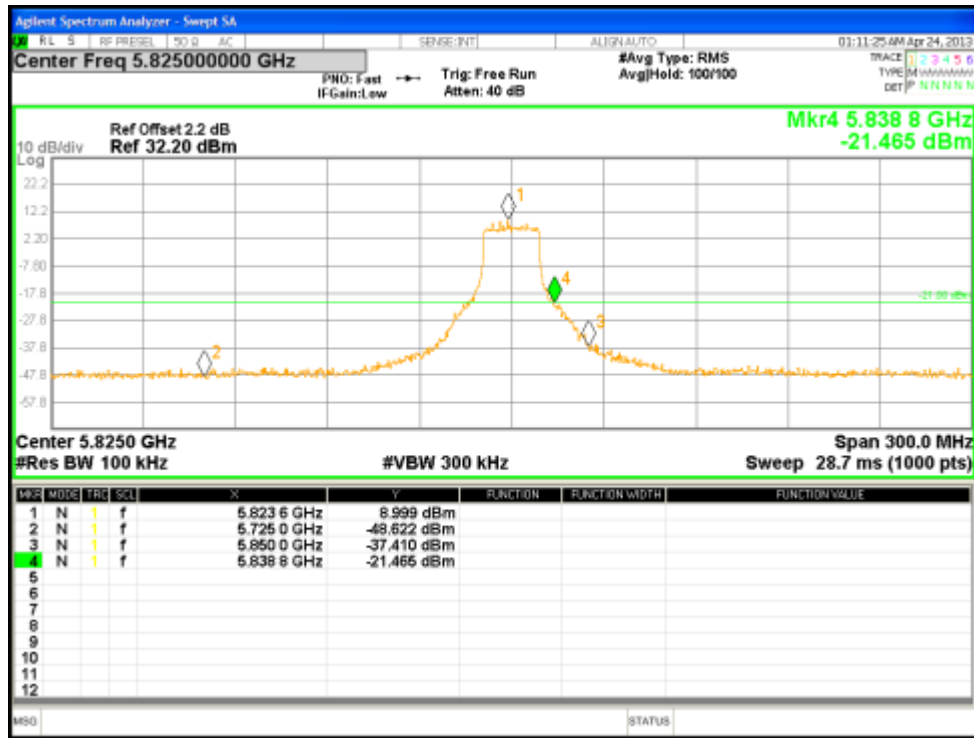

Figure 85: Reference Level for HT20 at 5825 MHz, Chain 0

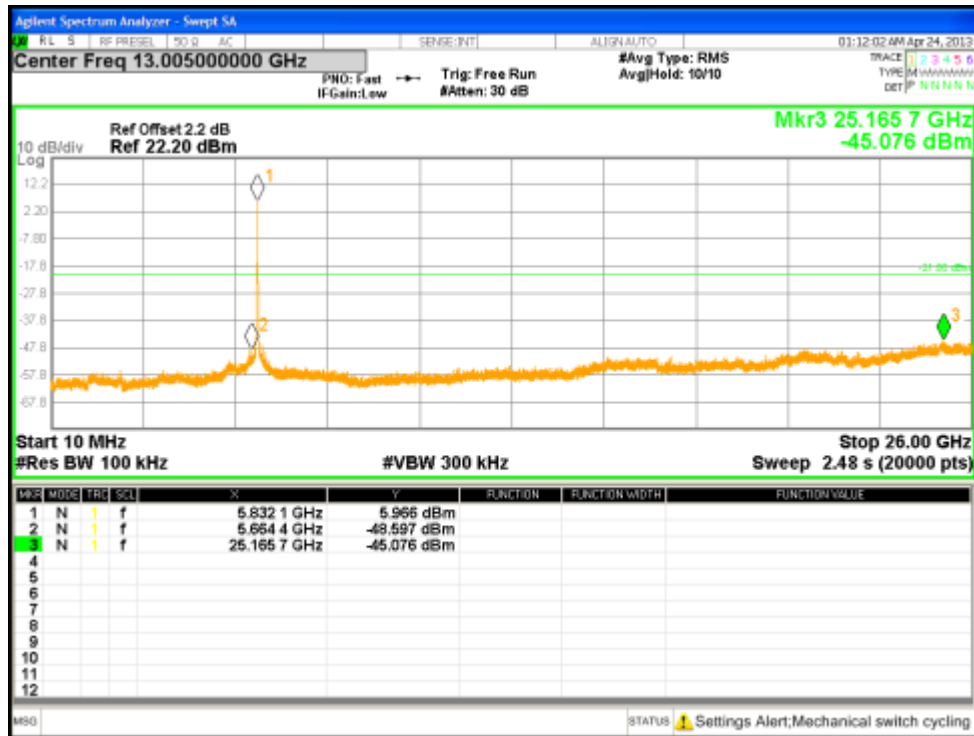
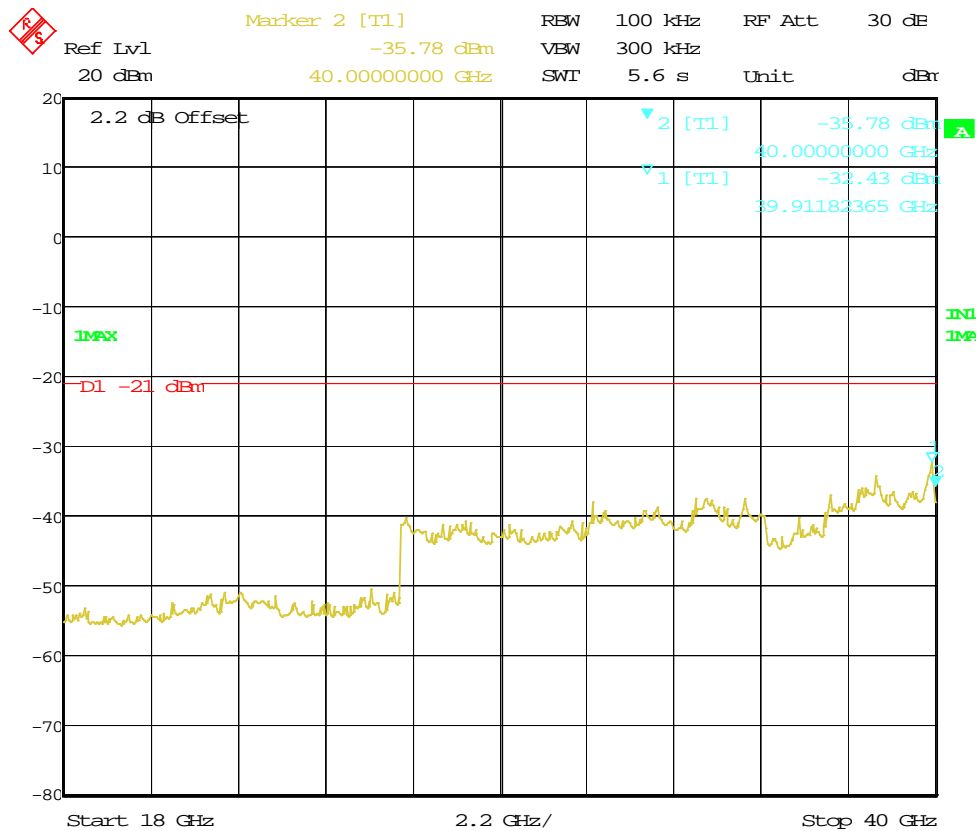

Figure 86: Out of Band Emission for HT20 at 5825 MHz, Chain 0



Date: 25.MAR.2013 15:17:22

Figure 87: Out of Band Emission for HT20 at 5825 MHz, Chain 0

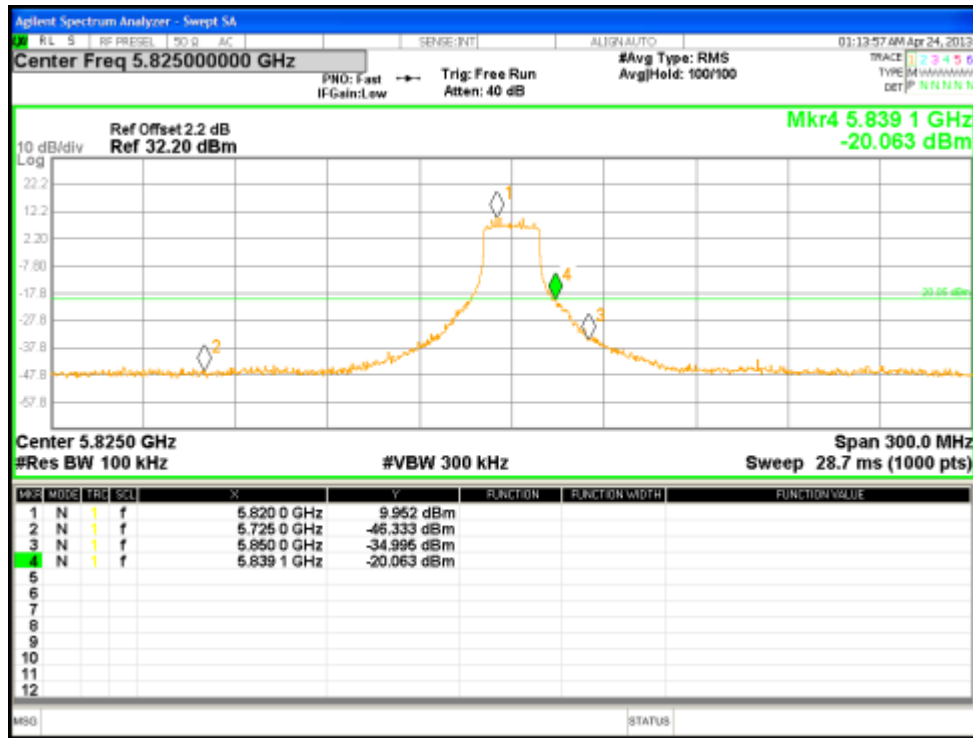

Figure 88: Reference Level for HT20 at 5825 MHz, Chain 1

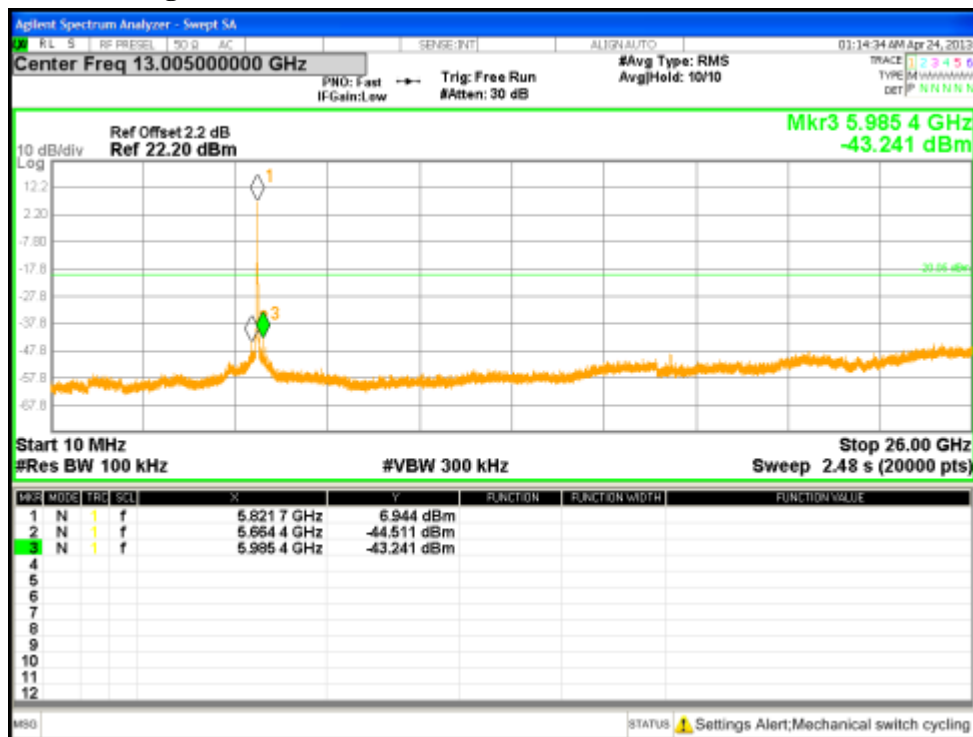
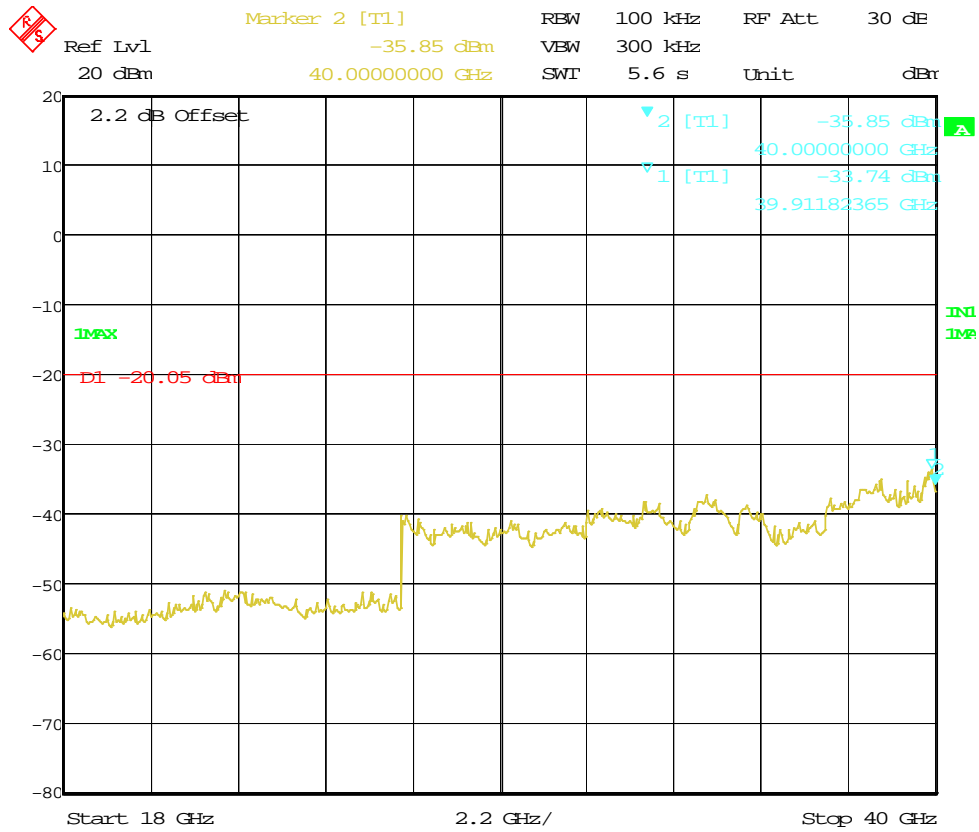

Figure 89: Out of Band Emission for HT20 at 5825 MHz, Chain 1



Date: 25.MAR.2013 15:18:34

Figure 90: Out of Band Emission for HT20 at 5825 MHz, Chain 1

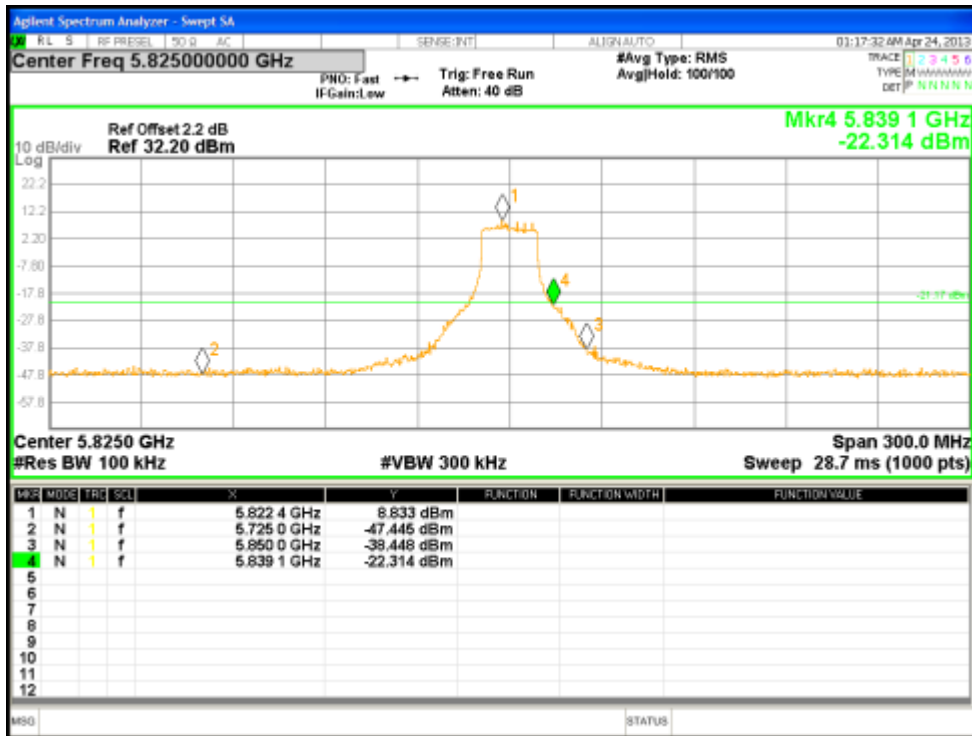

Figure 91: Reference Level for HT20 at 5825 MHz, Chain 2

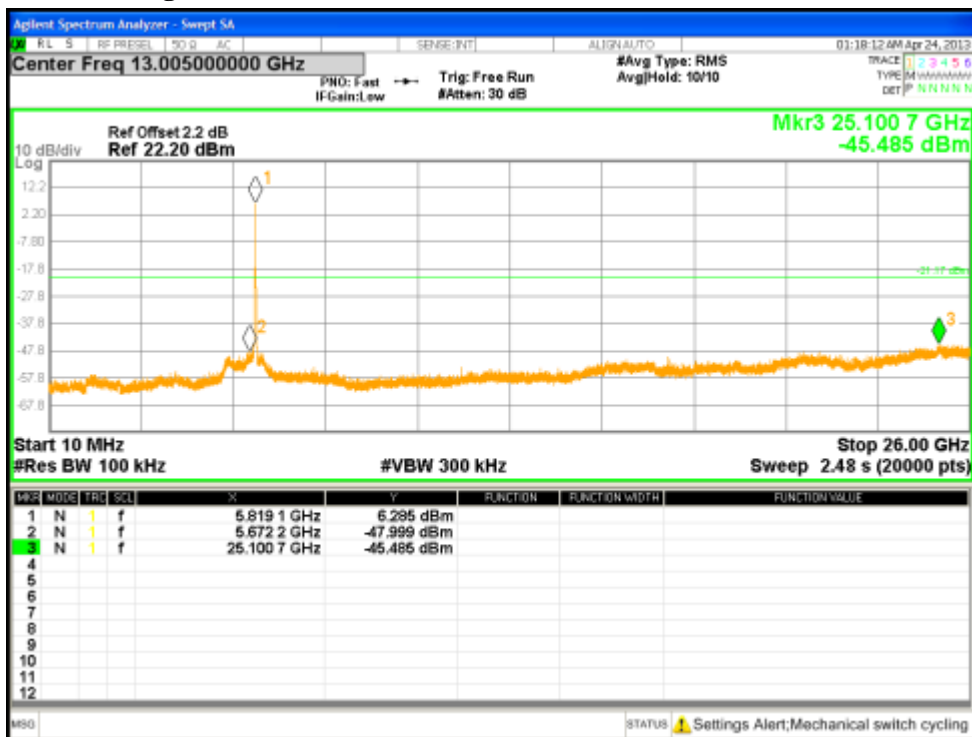
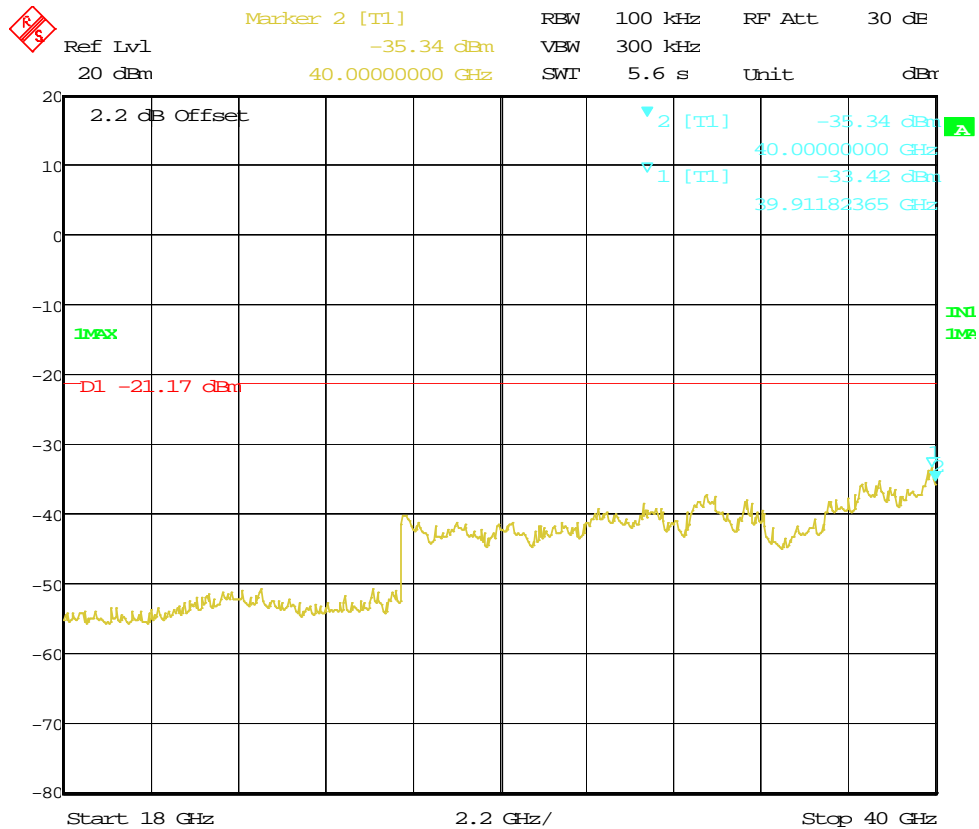

Figure 92: Out of Band Emission for HT20 at 5825 MHz, Chain 2



Date: 25.MAR.2013 15:19:43

Figure 93: Out of Band Emission for HT20 at 5825 MHz, Chain 2

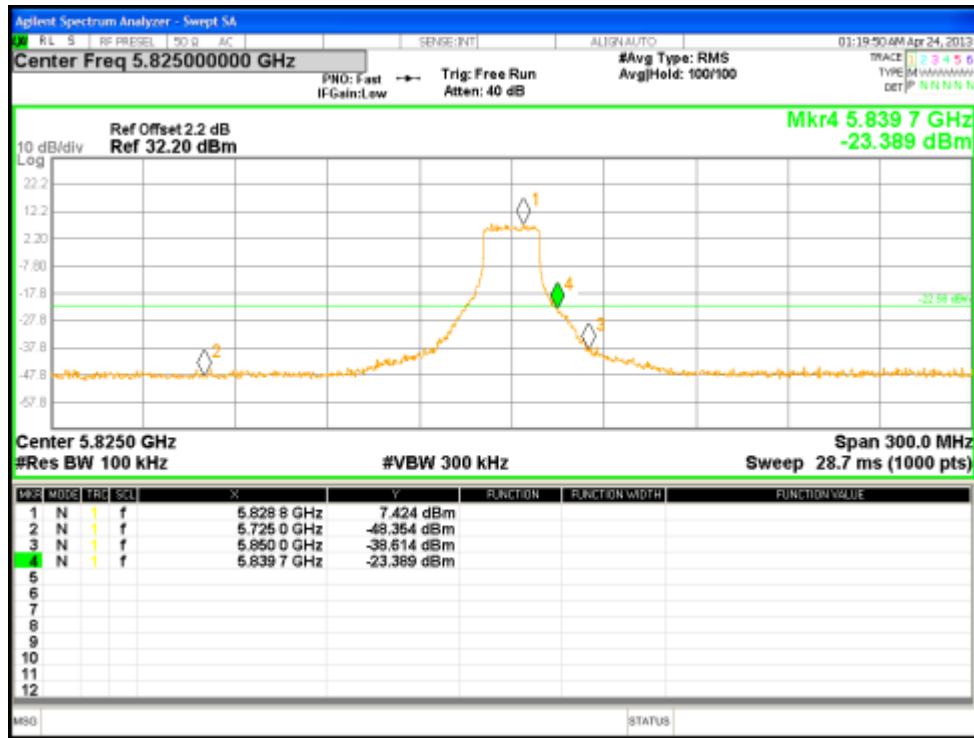

Figure 94: Reference Level for HT20 at 5825 MHz, Chain 3

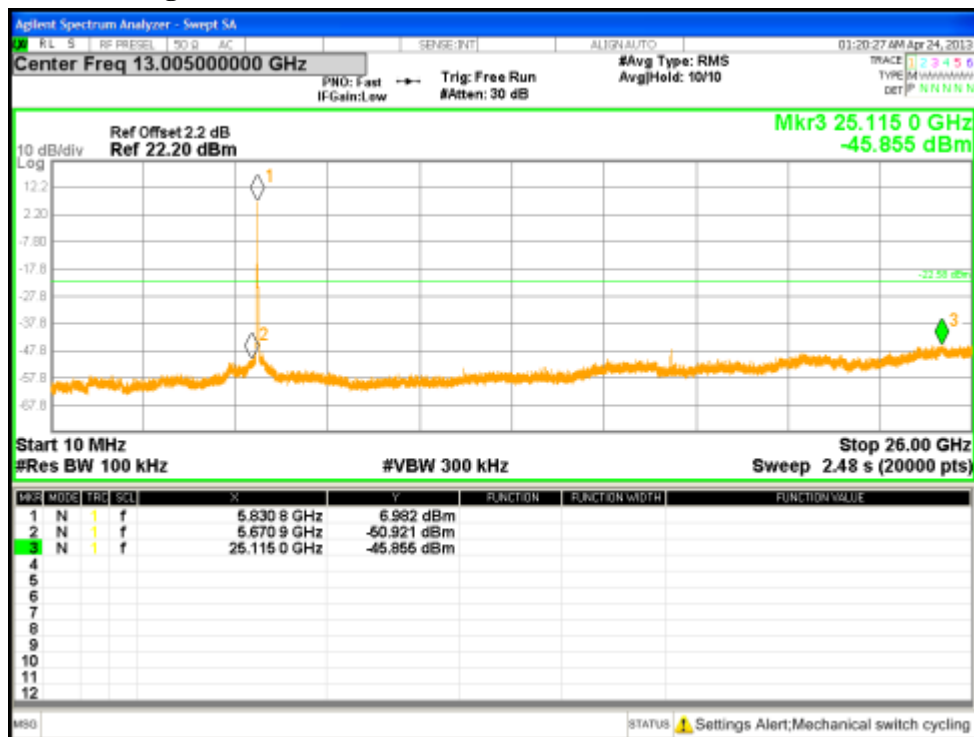
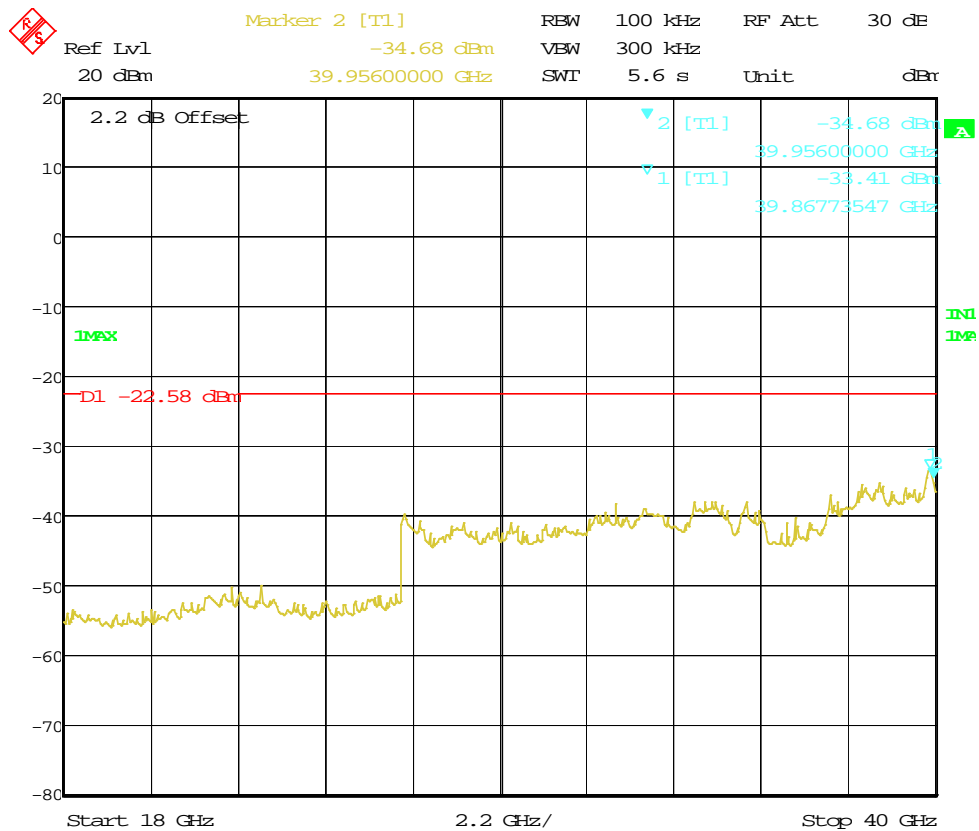
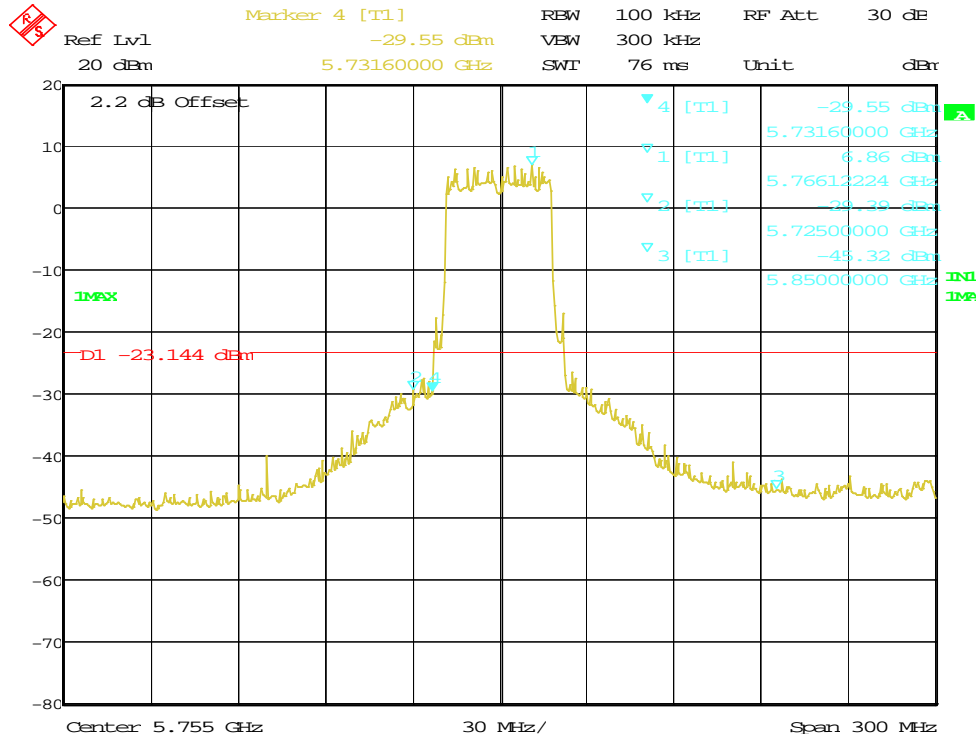

Figure 95: Out of Band Emission for HT20 at 5825 MHz, Chain 3



Date: 25.MAR.2013 15:20:46

Figure 96: Out of Band Emission for HT20 at 5825 MHz, Chain 3



Date: 25.MAR.2013 16:01:26

Figure 97: Reference Level for HT40 at 5755 MHz, Chain 0

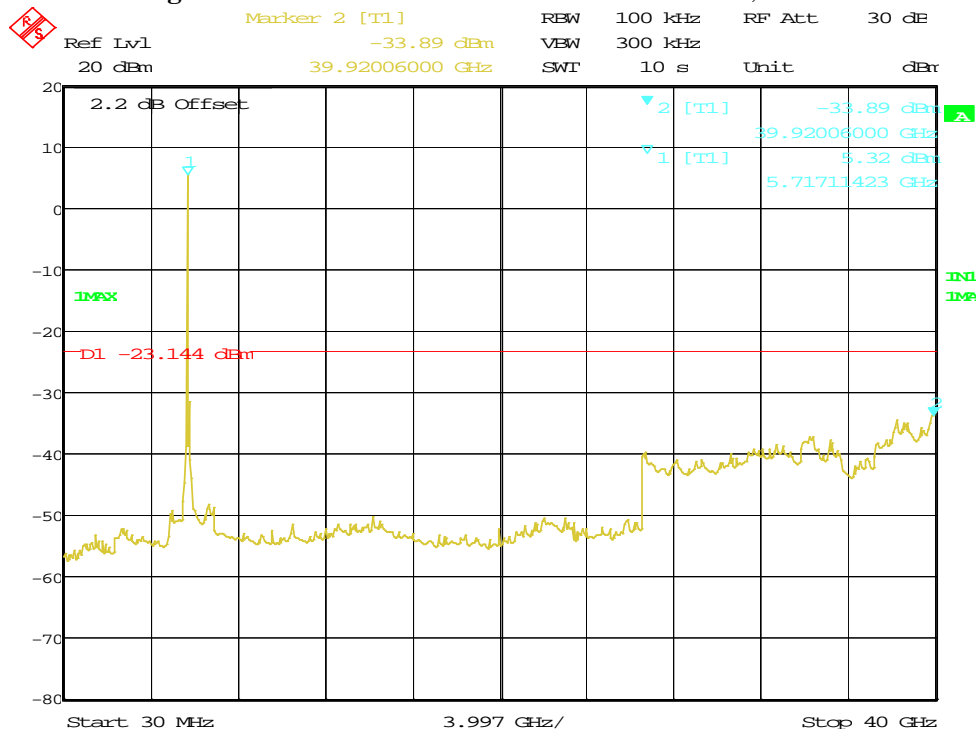

Date: 25.MAR.2013 16:02:02

Figure 98: Out of Band Emission for HT40 at 5755 MHz, Chain 0

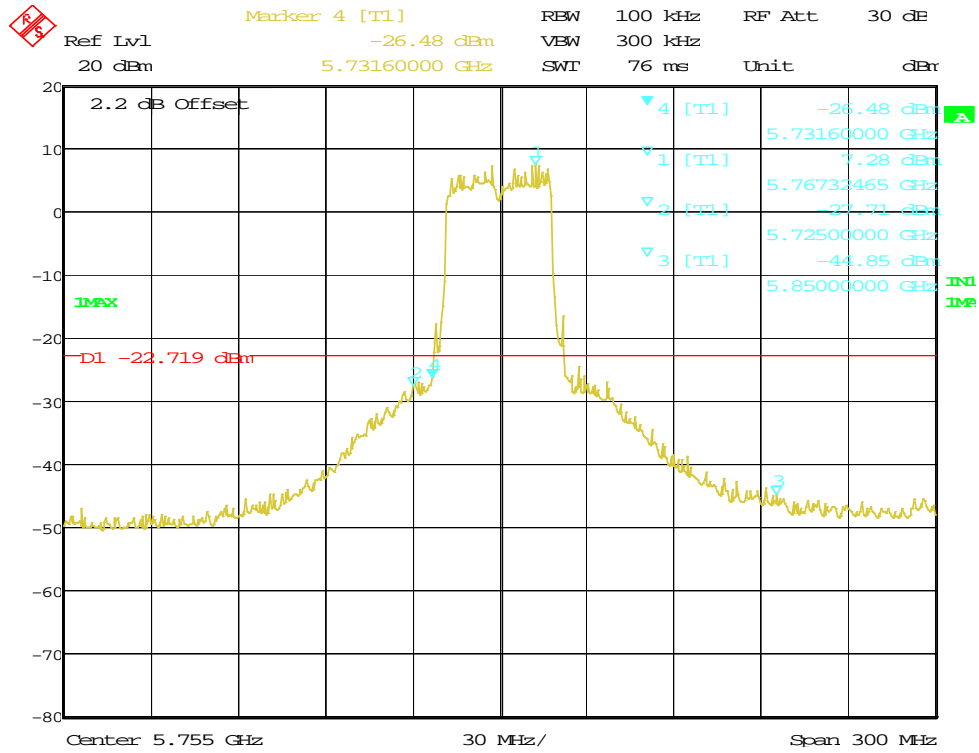

Date: 25.MAR.2013 16:03:23

Figure 99: Reference Level for HT40 at 5755 MHz, Chain 1

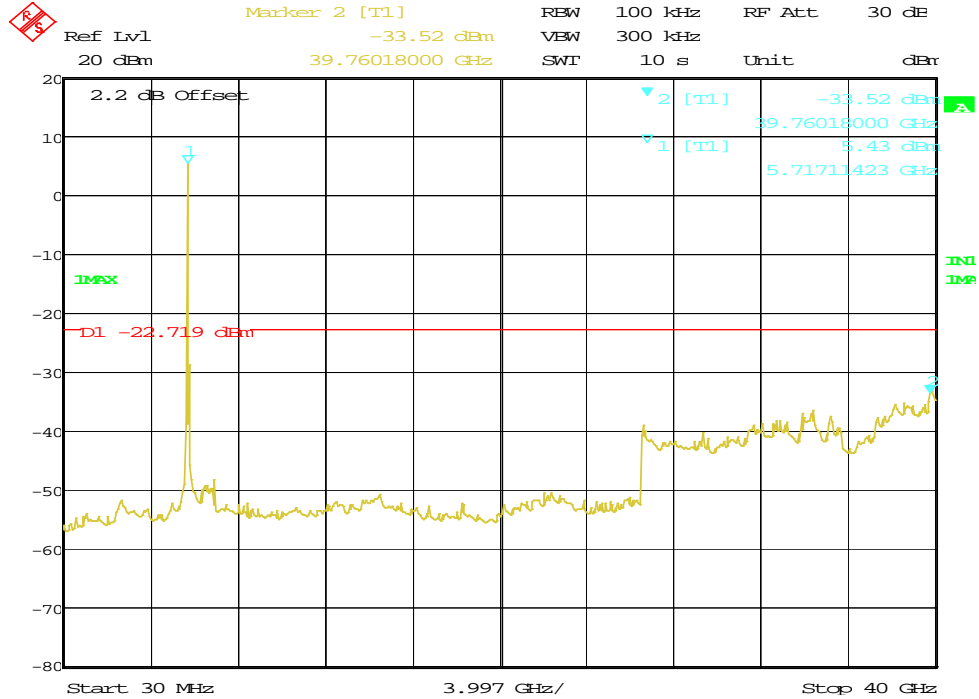

Date: 25.MAR.2013 16:03:59

Figure 100: Out of Band Emission for HT40 at 5755 MHz, Chain 1

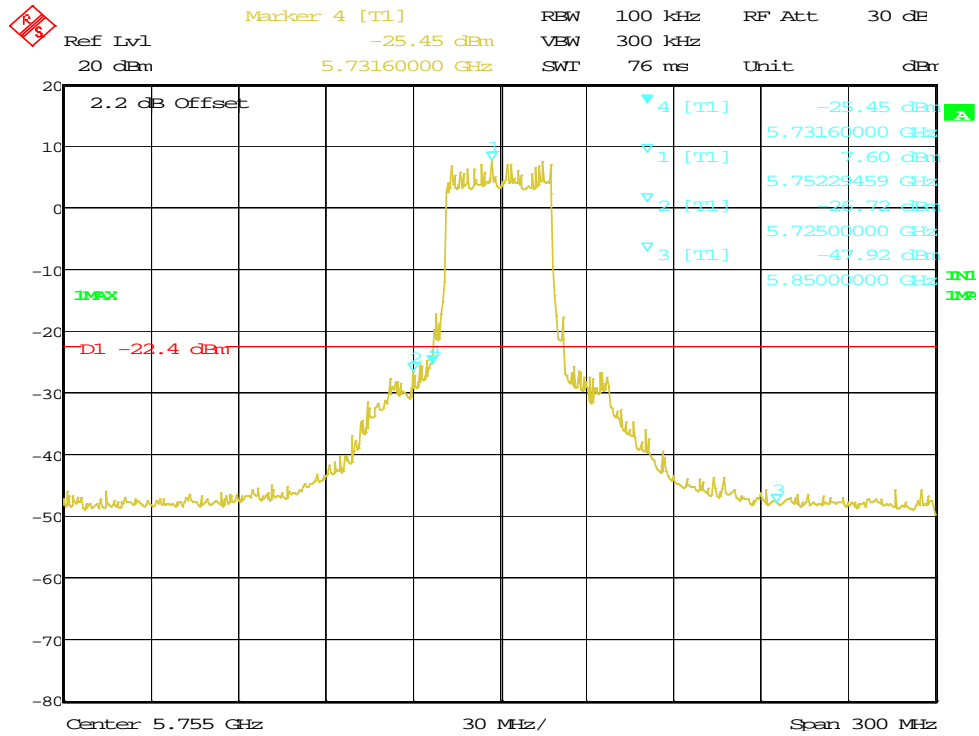

Date: 25.MAR.2013 16:04:54

Figure 101: Reference Level for HT40 at 5755 MHz, Chain 2

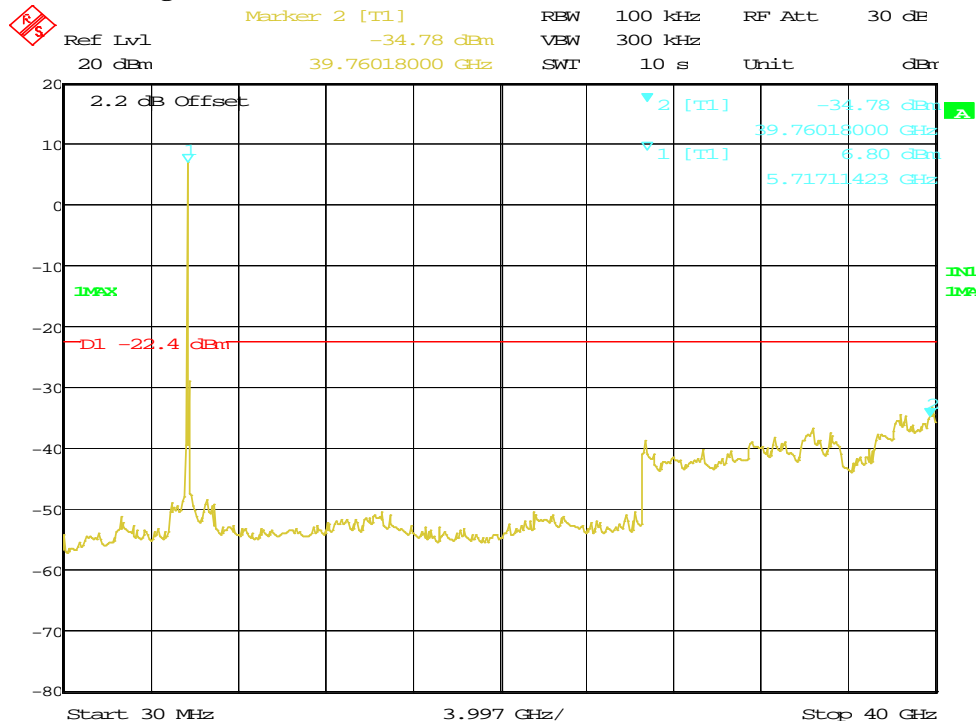

Date: 25.MAR.2013 16:05:30

Figure 102: Out of Band Emission for HT40 at 5755 MHz, Chain 2

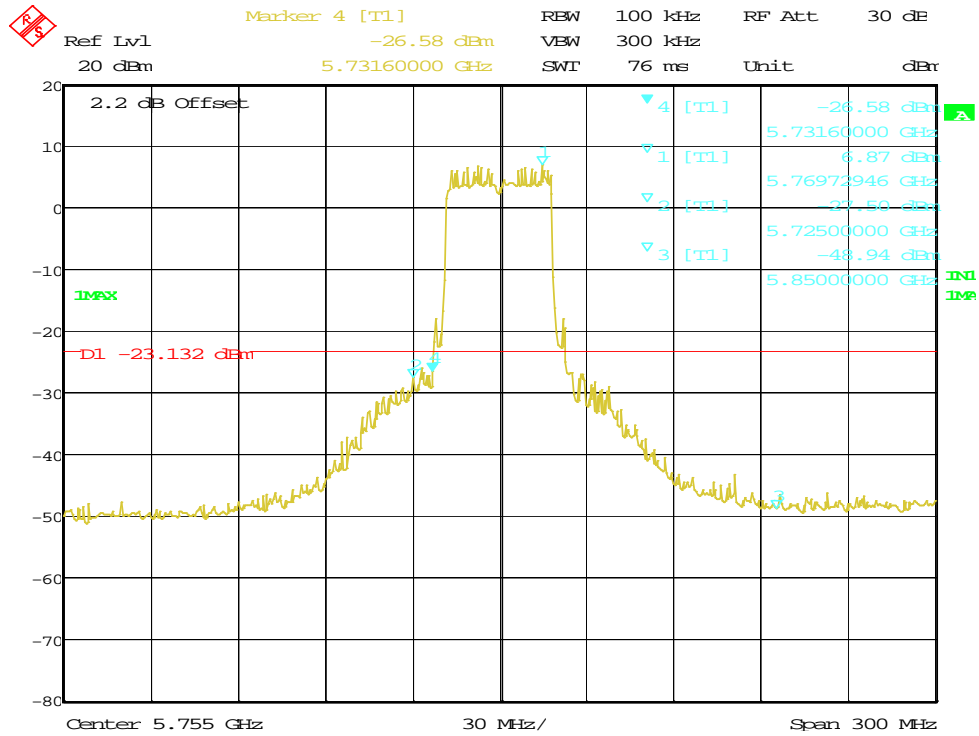

Date: 25.MAR.2013 16:06:23

Figure 103: Reference Level for HT40 at 5755 MHz, Chain 3

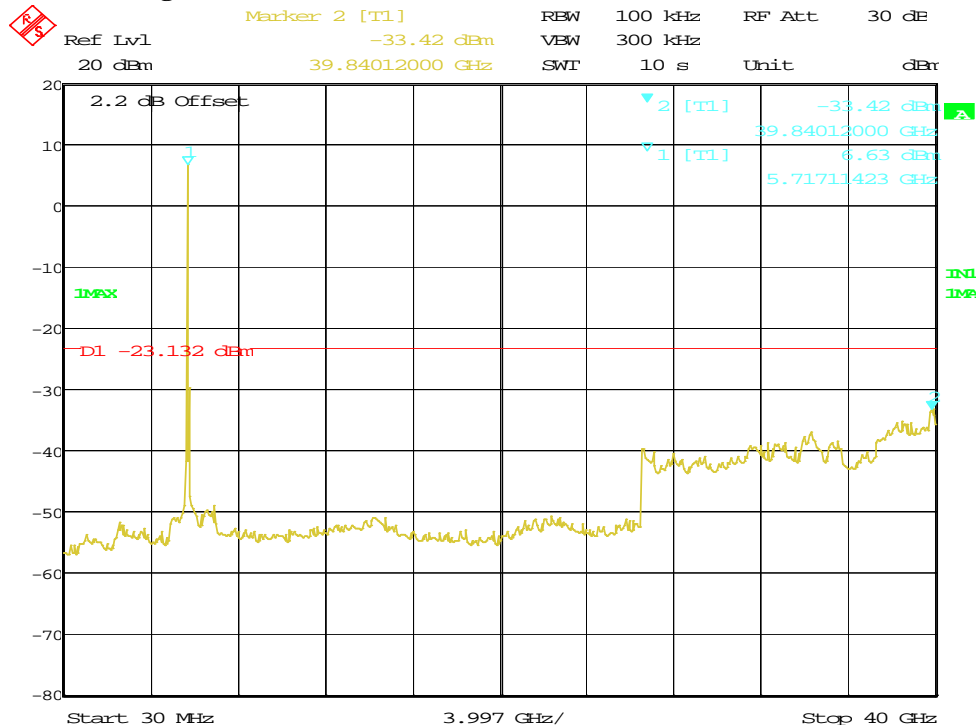

Date: 25.MAR.2013 16:06:59

Figure 104: Out of Band Emission for HT40 at 5755 MHz, Chain 3

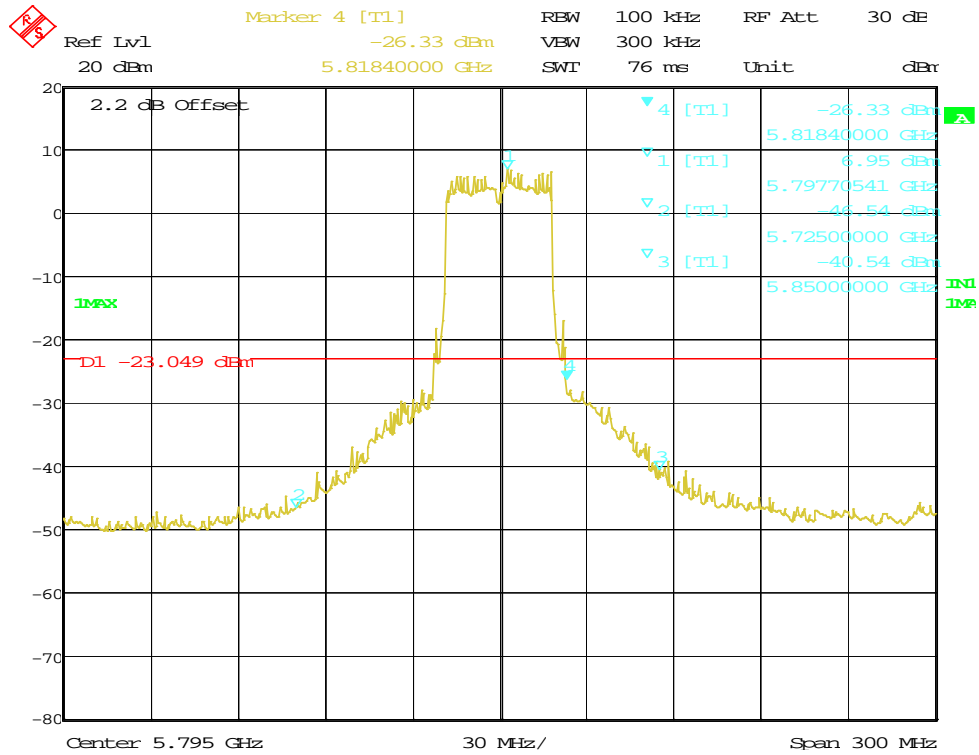

Date: 25.MAR.2013 16:09:03

Figure 105: Reference Level for HT40 at 5795 MHz, Chain 0

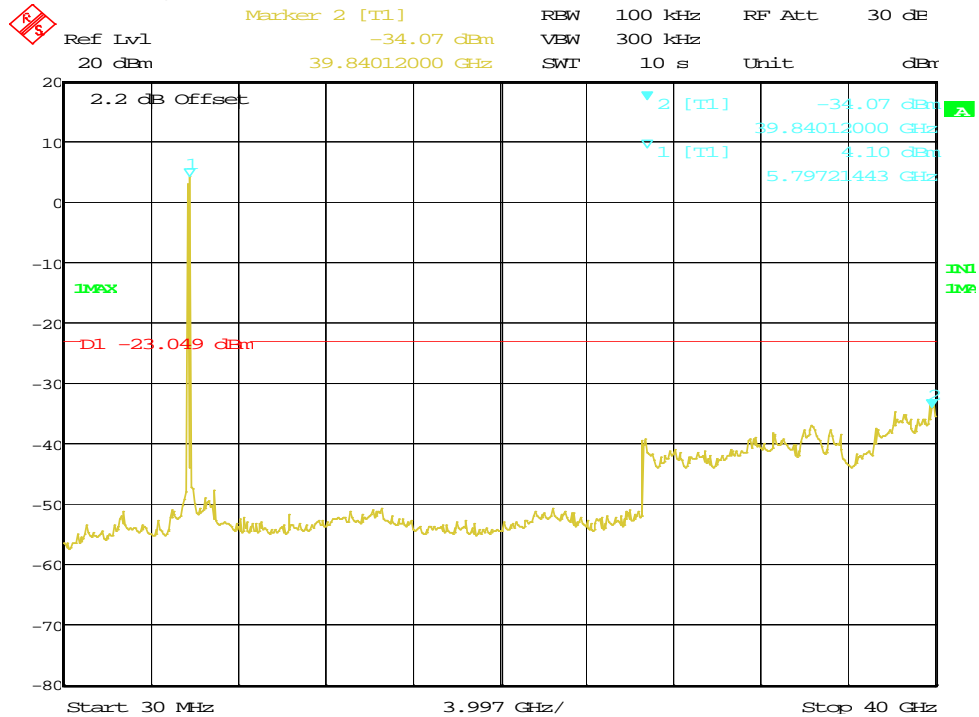

Date: 25.MAR.2013 16:09:39

Figure 106: Out of Band Emission for HT40 at 5795 MHz, Chain 0

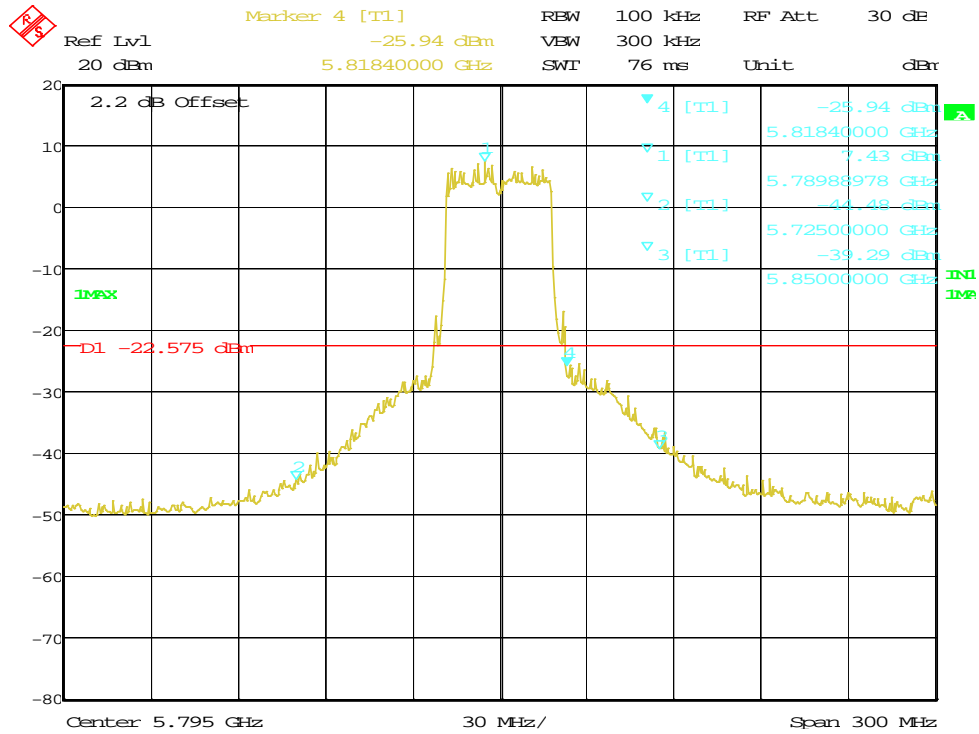

Date: 25.MAR.2013 16:10:33

Figure 107: Reference Level for HT40 at 5795 MHz, Chain 1

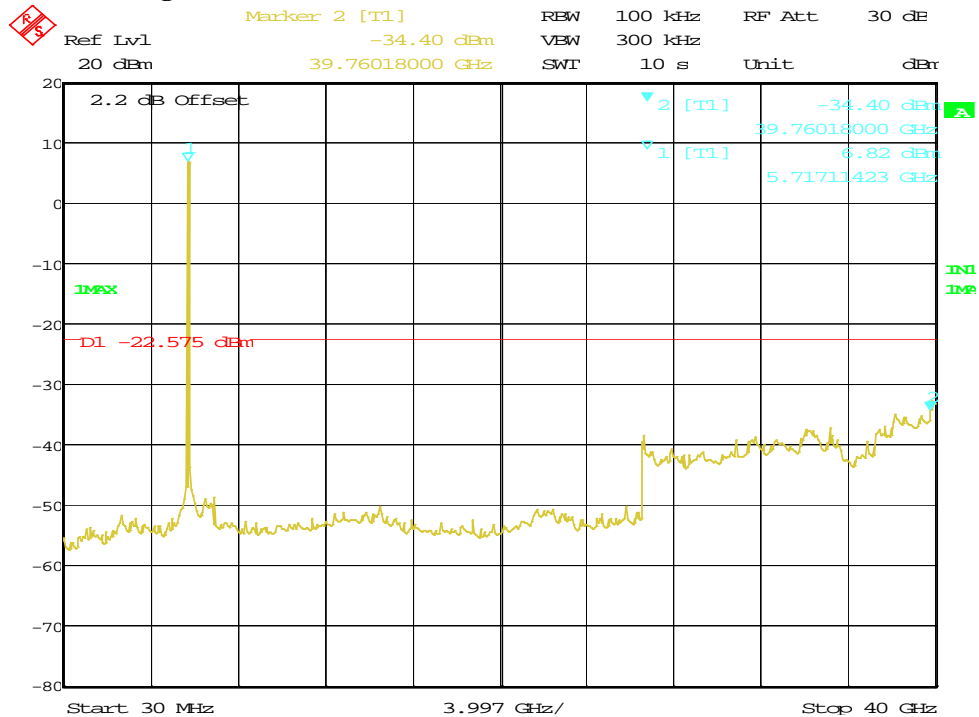

Date: 25.MAR.2013 16:11:08

Figure 108: Out of Band Emission for HT40 at 5795 MHz, Chain 1

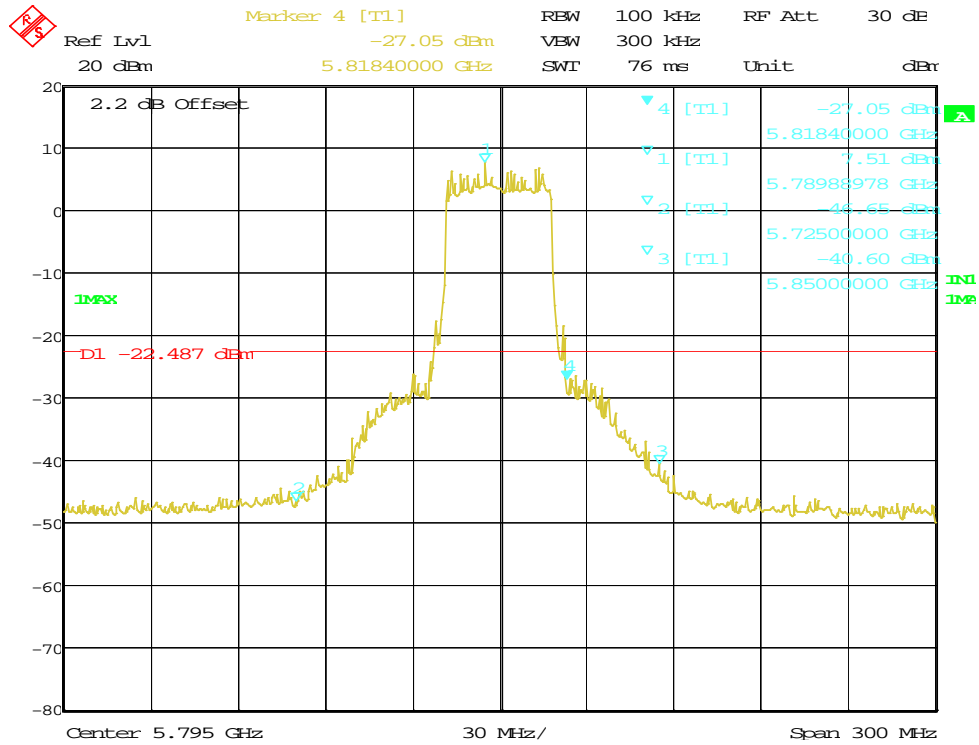

Date: 25.MAR.2013 16:11:57

Figure 109: Reference Level for HT40 at 5795 MHz, Chain 2

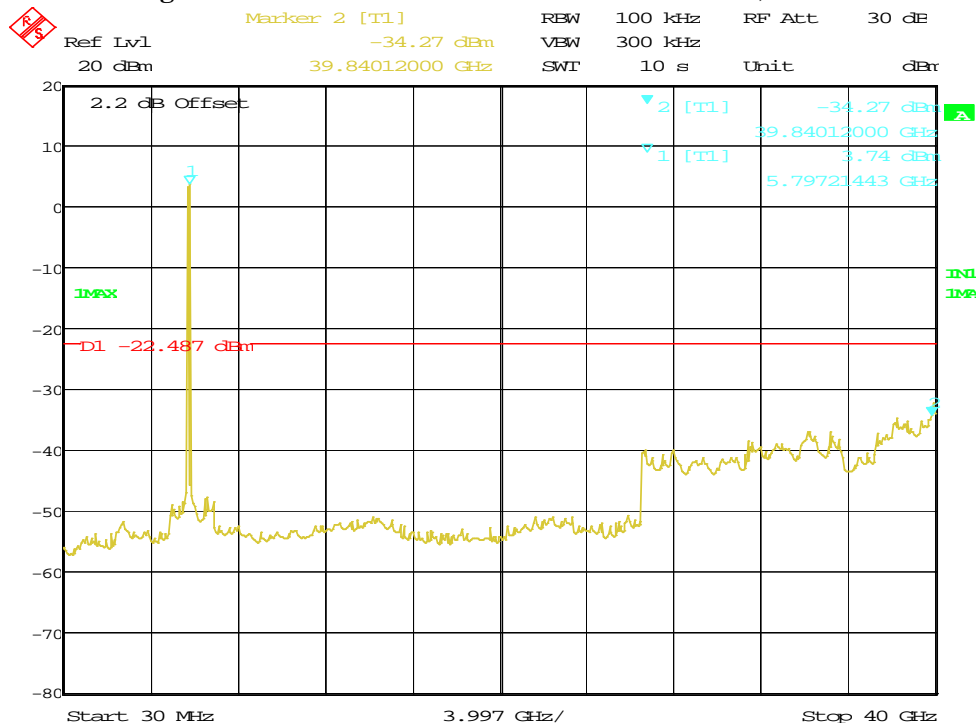

Date: 25.MAR.2013 16:12:33

Figure 110: Out of Band Emission for HT40 at 5795 MHz, Chain 2

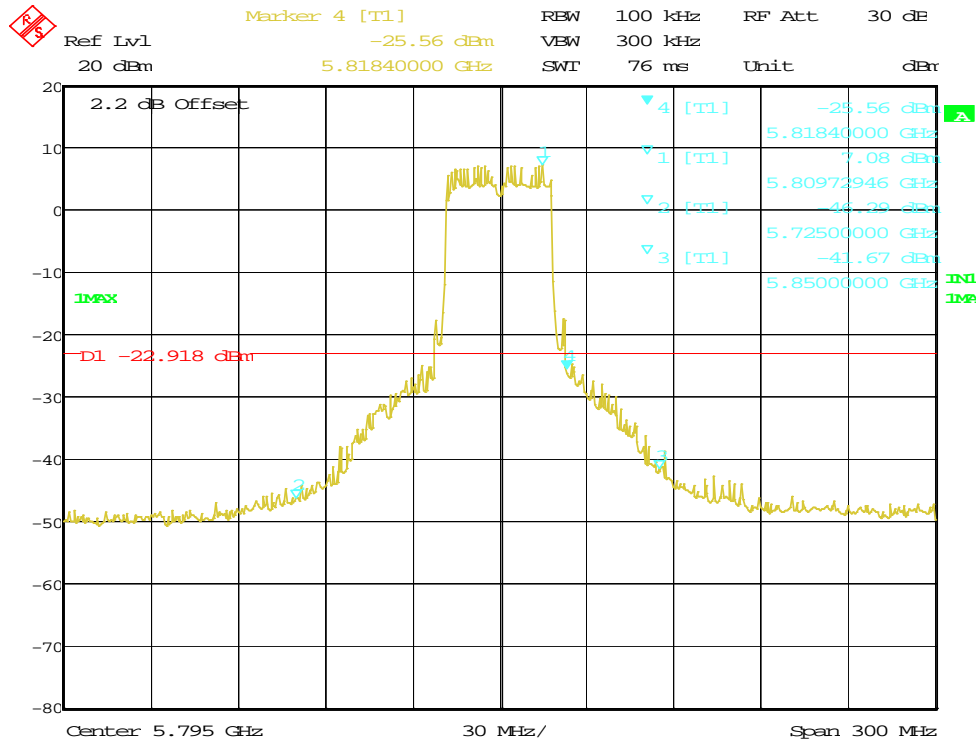

Date: 25.MAR.2013 16:13:24

Figure 111: Reference Level for HT40 at 5795 MHz, Chain 3

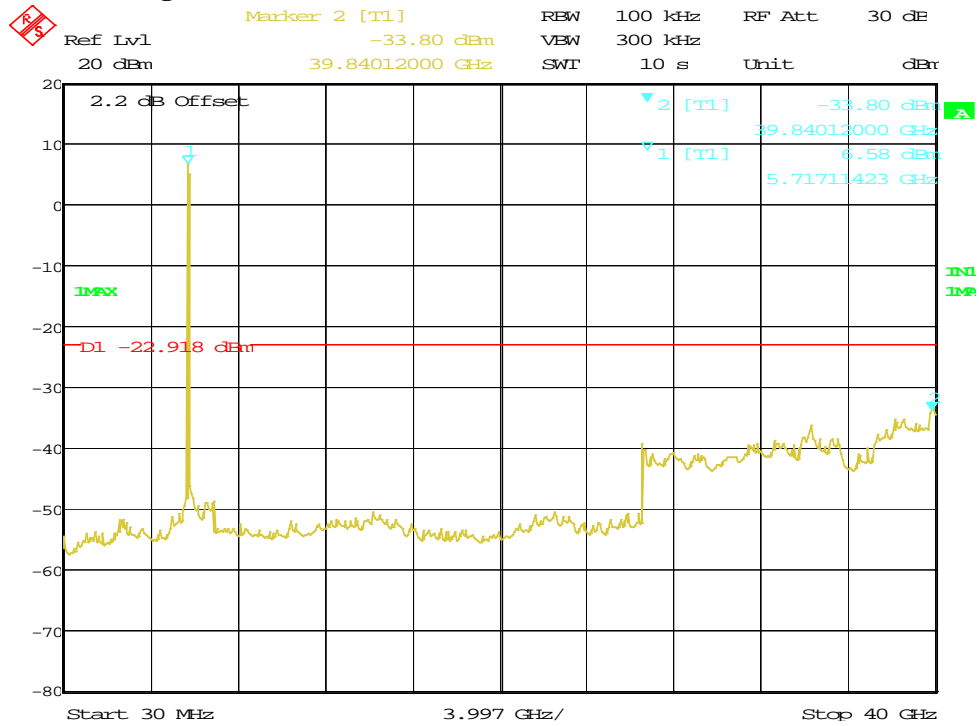

Date: 25.MAR.2013 16:14:00

Figure 112: Out of Band Emission for HT40 at 5795 MHz, Chain 3

4.4 Peak Power Spectral Density

According to the CFR47 Part 15.247 (e) and RSS 210 (A8.2), the spectral power density output of the antenna port shall be less than 8dBm in any 3kHz band during any time interval of continuous transmission.

4.4.1 Test Method

The conducted method was used to measure the channel peak power spectral density per ANSI C63.10-2009 Section 6.11.2. The measurement was performed with modulation per CFR47 Part 15.247 (e) and RSS 210 (A8.2). This test was conducted on 3 channels of Sample, S/N 09130M000104. The worst findings were conducted on 3 channels in each operating mode of 5725 MHz to 5850 MHz indicated below.

Test Setup:

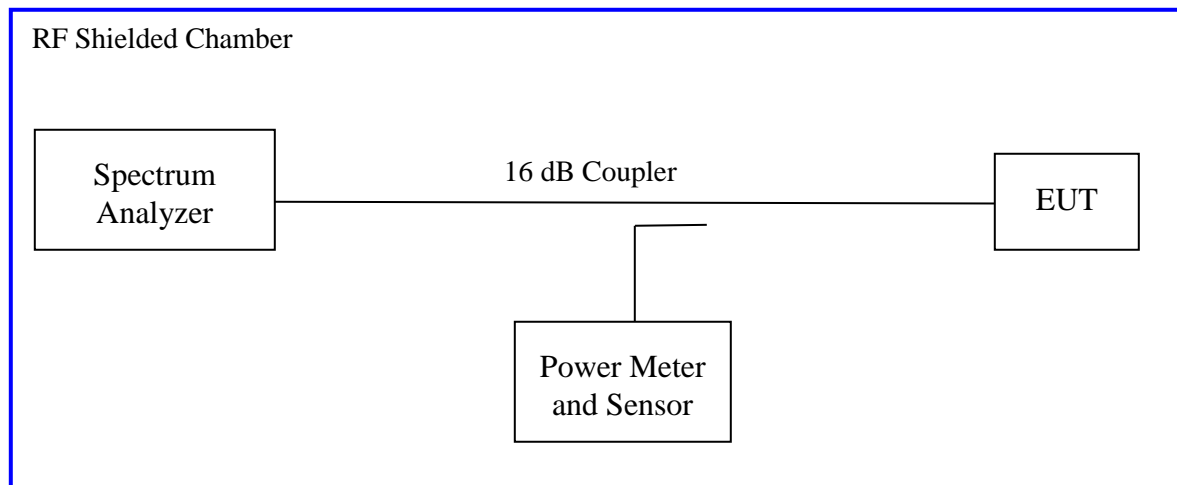

Measurement procedure AVGPS-1 of KDB 558074 D01 DTS Meas. Guidance v03r01 was applied.

4.4.2 Results

As originally tested, the EUT was found to be compliant to the requirements of the test standard(s).

Table 6: Peak Power Spectral Density – Test Results

Test Conditions: Conducted Measurement, Normal Temperature and Voltage only								
Antenna Type: Integrated				Power Setting: See Test plan				
Max. Directional Gain: + 8 dBi				Signal State: Modulated at 100%.				
Ambient Temp.: 23 °C				Relative Humidity: 32%				
Peak Power Spectral Density								
802.11n (HT20) Mode								
Freq. (MHz)	Ch0 [dBm]	Ch1 [dBm]	Ch2 [dBm]	Ch3 [dBm]	CF [dB]	Max. PPSD [dBm]	Limit [dBm]	Margin [dB]
5745	1.41	2.83	2.03	1.59	-9.21	-6.40	6.00	-12.40
5785	0.757	1.663	1.291	1.016	-9.21	-7.57	6.00	-13.57
5825	1.228	3.986	1.458	1.152	-9.21	-5.24	6.00	-11.24
Note: 1. The highest peak output power was observed at HT20 6.5 Mbps per data stream. 2. $CF = (10 * \text{Log}(3\text{kHz}/100\text{kHz})) + (10 * \text{Log}(N))$ where N is accounted for the number of data streams being used per KDB 662911. 3. The total directional gain would be 8dBi; 2dBi + 10*Log(4). Per CFR47 Part 15.247, the limit is reduced for every dBi gain exceeding 6dBi. The limit would be 6.00 dBm.								
802.11n (HT40) Mode								
Freq. (MHz)	Ch0 [dBm]	Ch1 [dBm]	Ch2 [dBm]	Ch3 [dBm]	CF [dB]	Max. PPSD [dBm]	Limit [dBm]	Margin [dB]
5755	-4.29	-4.12	-4.29	-4.72	-9.21	-13.33	6.00	-19.33
5795	-5.10	-4.73	-3.32	-4.91	-9.21	-12.53	6.00	-18.53
Note: 1. The highest peak output power was observed at HT40 13.5 Mbps per data stream. 2. $CF = (10 * \text{Log}(3\text{kHz}/100\text{kHz})) + (10 * \text{Log}(N))$ where N is accounted for the number of data streams being used per KDB 662911. 3. The total directional gain would be 8dBi; 2dBi + 10*Log(4). Per CFR47 Part 15.247, the limit is reduced for every dBi gain exceeding 6dBi. The limit would be 6.00 dBm.								

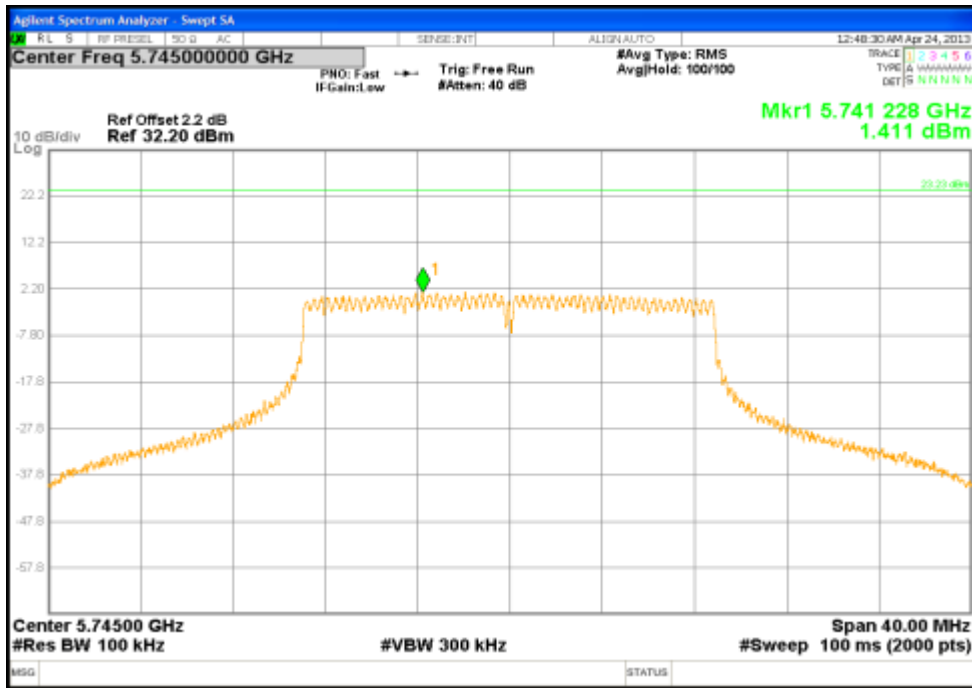

Figure 113: PPSD, 5745 MHz at 802.11n HT20, Chain 0 – 6.5 Mbps

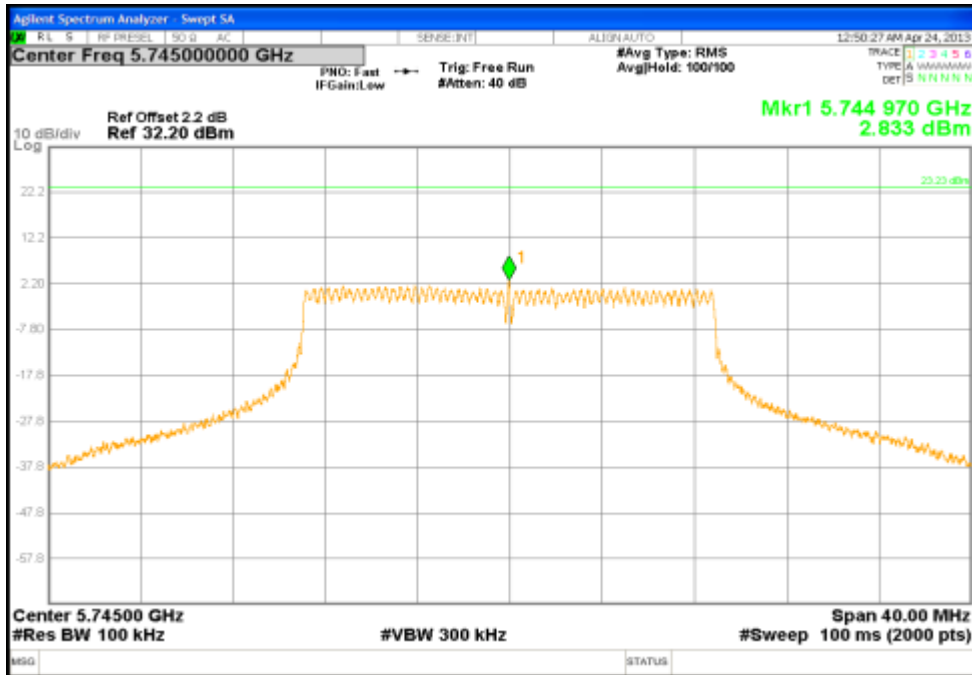

Figure 114: PPSD, 5745 MHz at 802.11n HT20, Chain 1 – 6.5 Mbps

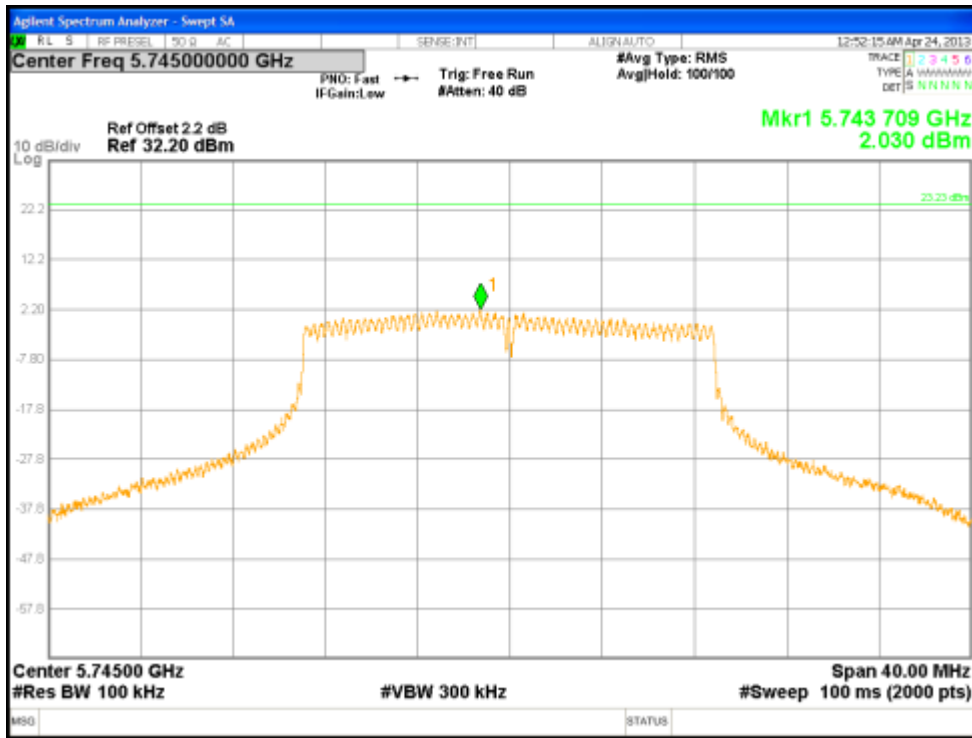

Figure 115: PPSD, 5745 MHz at 802.11n HT20, Chain 2 – 6.5 Mbps

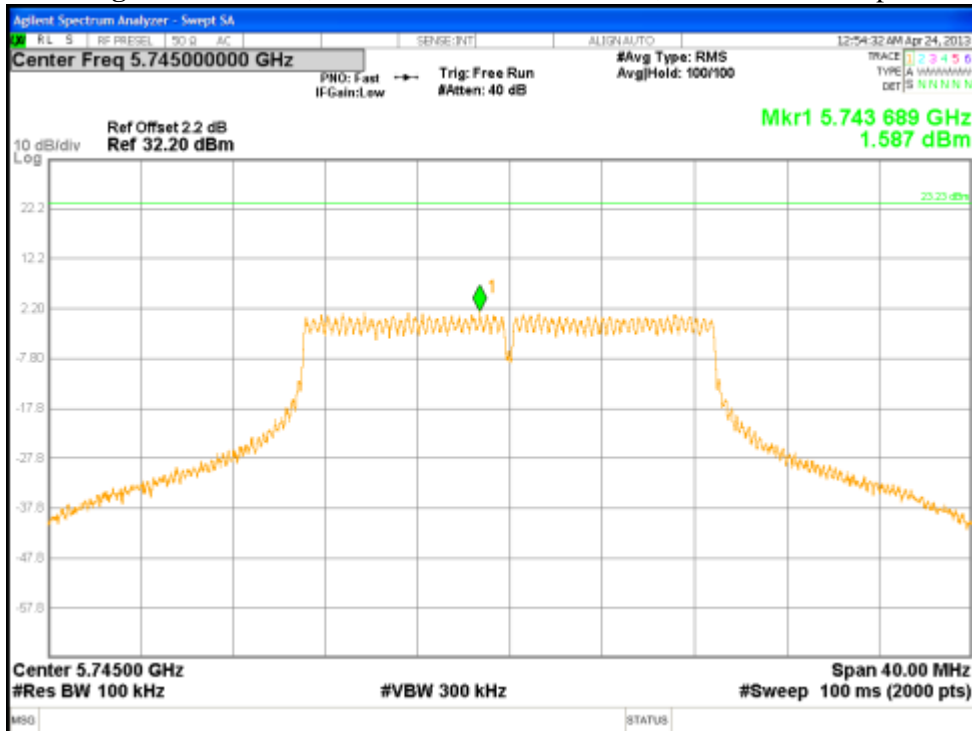

Figure 116: PPSD, 5745 MHz at 802.11n HT20, Chain 3 – 6.5 Mbps

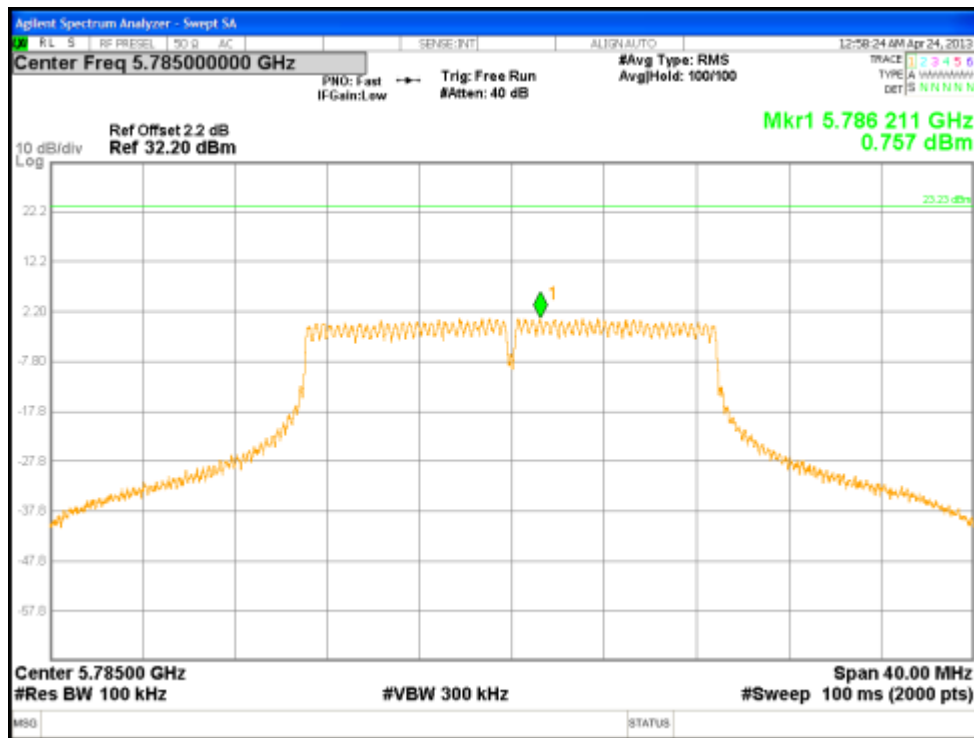

Figure 117: PPSD, 5785 MHz at 802.11n HT20, Chain 0 – 6.5 Mbps

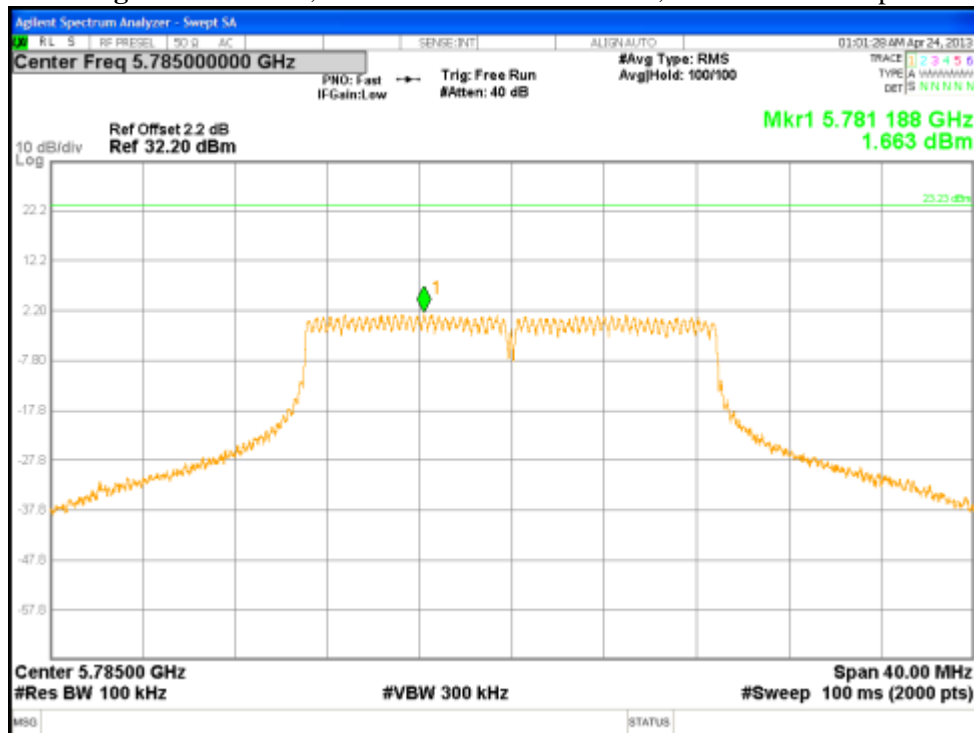

Figure 118: PPSD, 5785 MHz at 802.11n HT20, Chain 1 – 6.5 Mbps

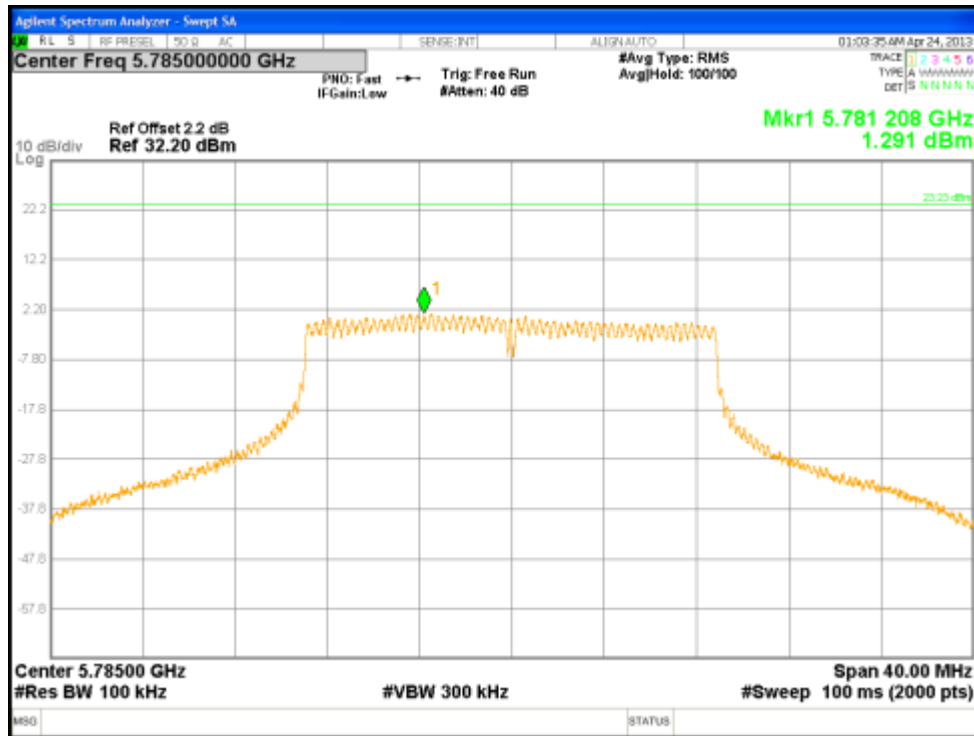

Figure 119: PPSD, 5785 MHz at 802.11n HT20, Chain 2 – 6.5 Mbps

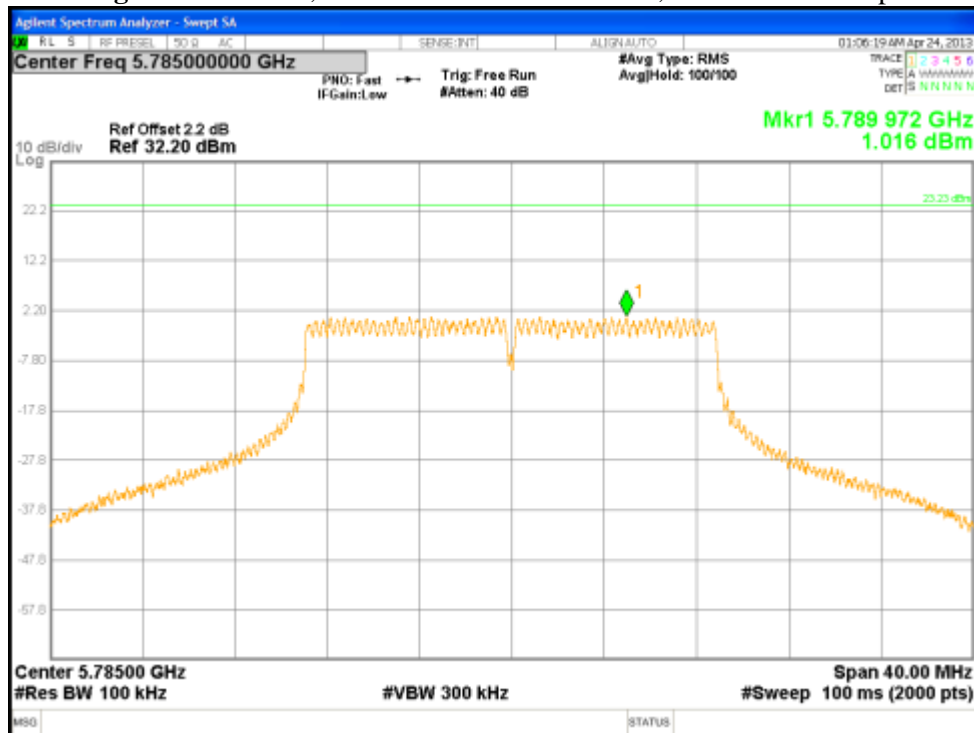

Figure 120: PPSD, 5785 MHz at 802.11n HT20, Chain 3 – 6.5 Mbps

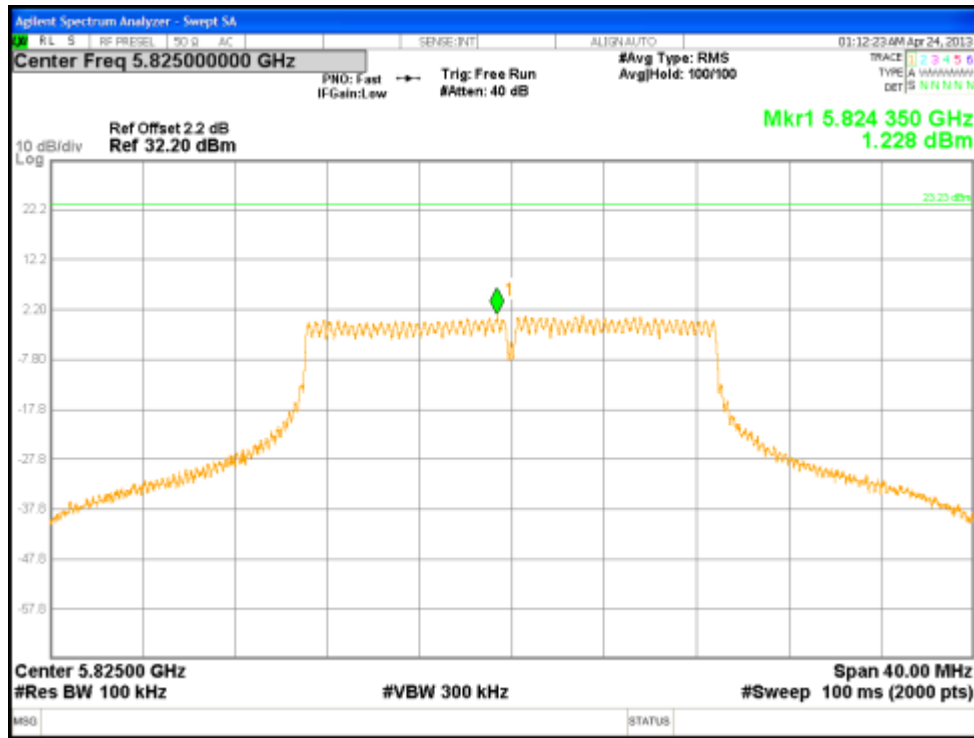

Figure 121: PPSD, 5825 MHz at 802.11n HT20, Chain 0 – 6.5 Mbps

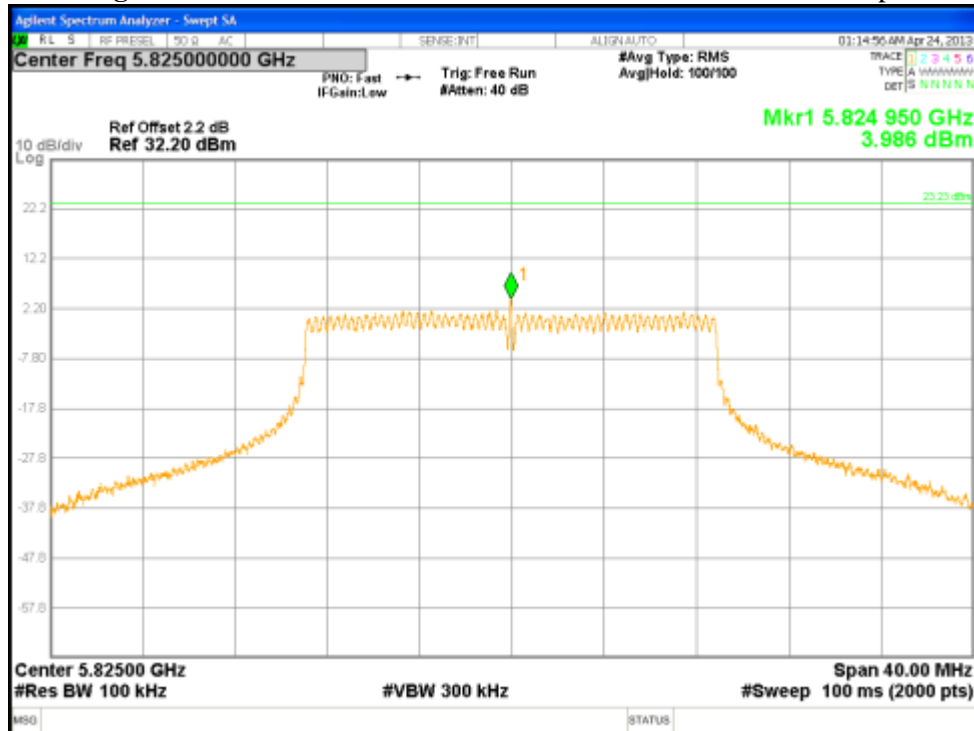

Figure 122: PPSD, 5825 MHz at 802.11n HT20, Chain 1 – 6.5 Mbps

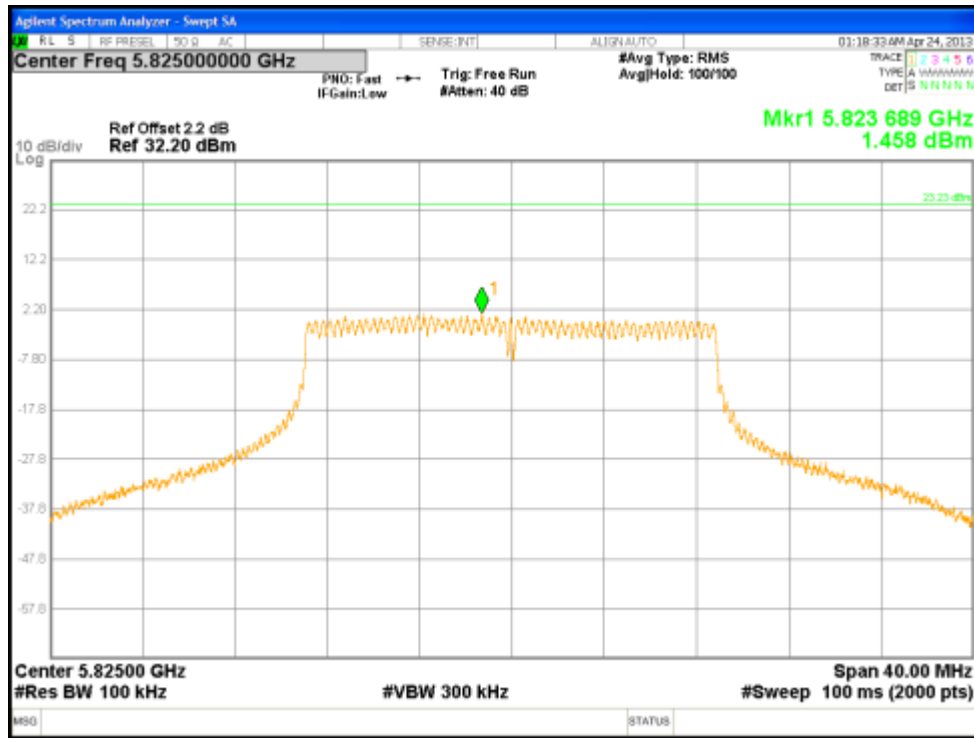

Figure 123: PPSD, 5825 MHz at 802.11n HT20, Chain 2 – 6.5 Mbps

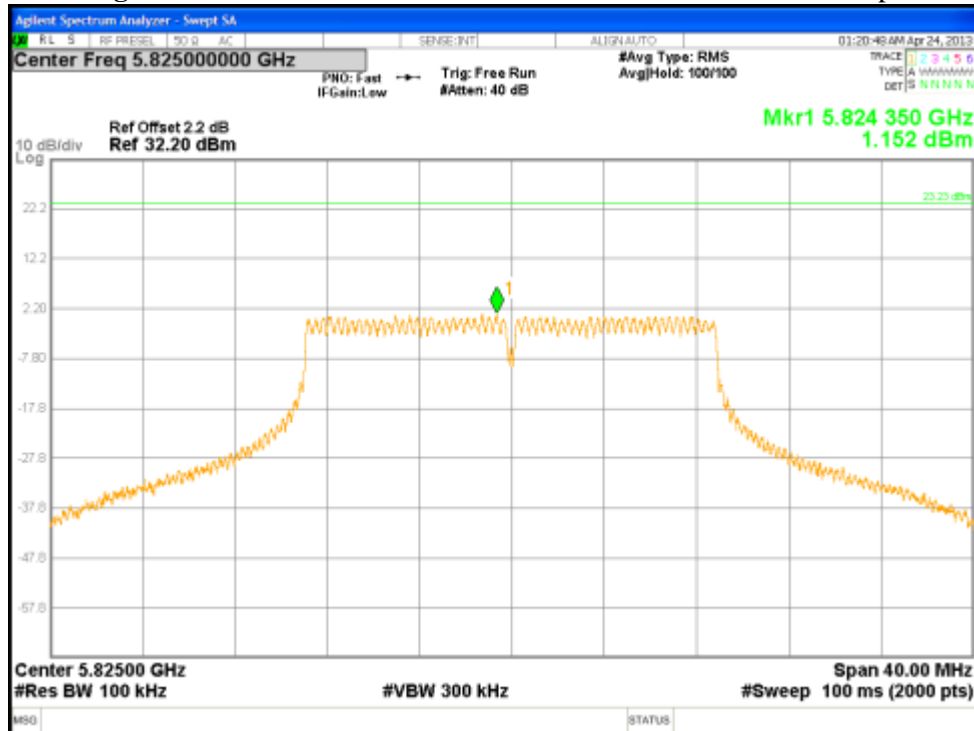

Figure 124: PPSD, 5825 MHz at 802.11n HT20, Chain 3 – 6.5 Mbps

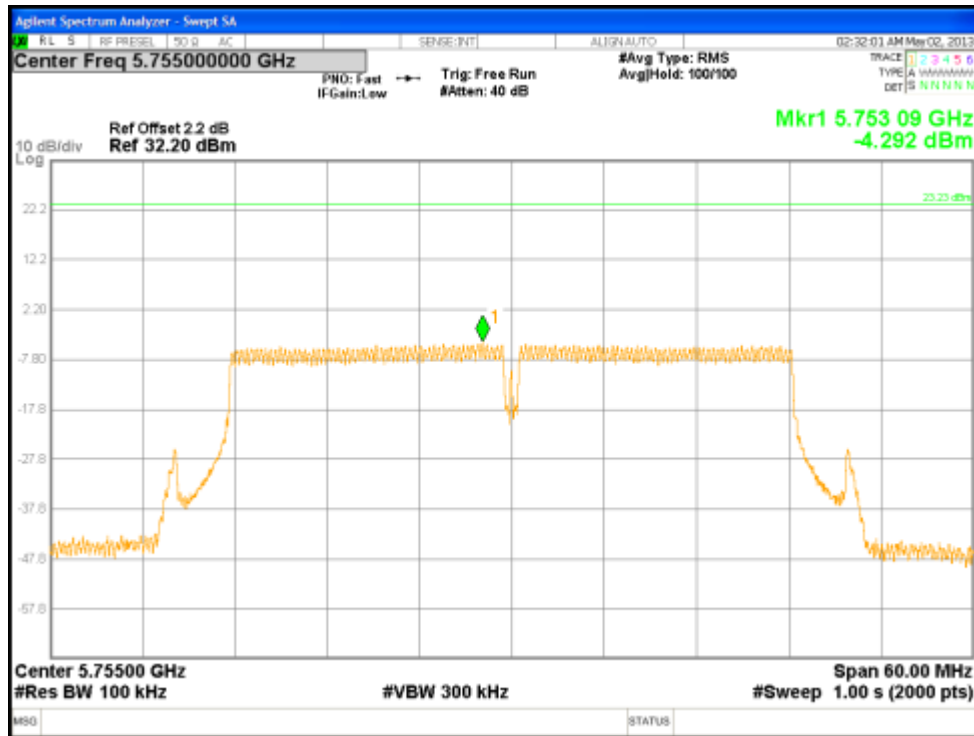

Figure 125: PPSD, 5755 MHz at 802.11n HT40, Chain 0 – 13.5 Mbps

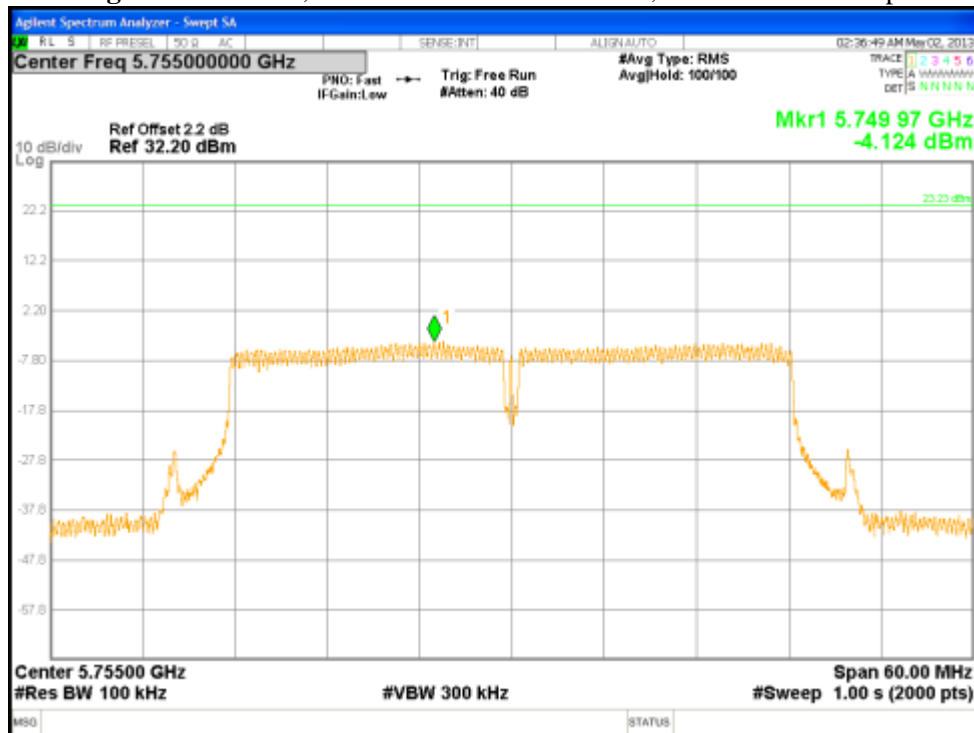

Figure 126: PPSD, 5755 MHz at 802.11n HT40, Chain 1 – 13.5 Mbps

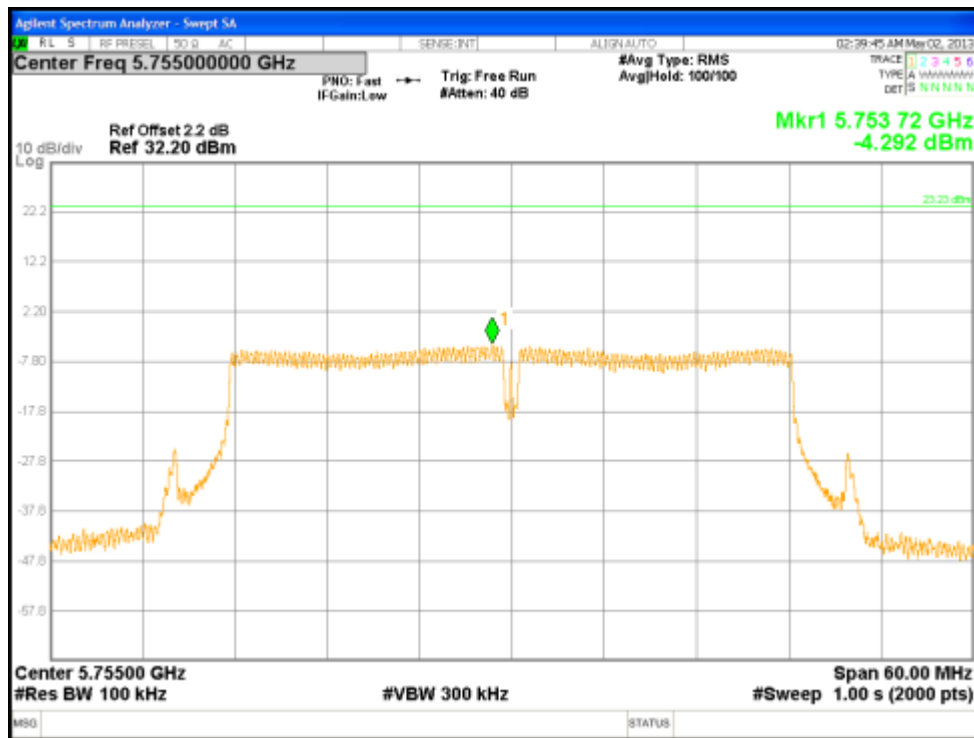

Figure 127: PPSD, 5755 MHz at 802.11n HT40, Chain 2 – 13.5 Mbps

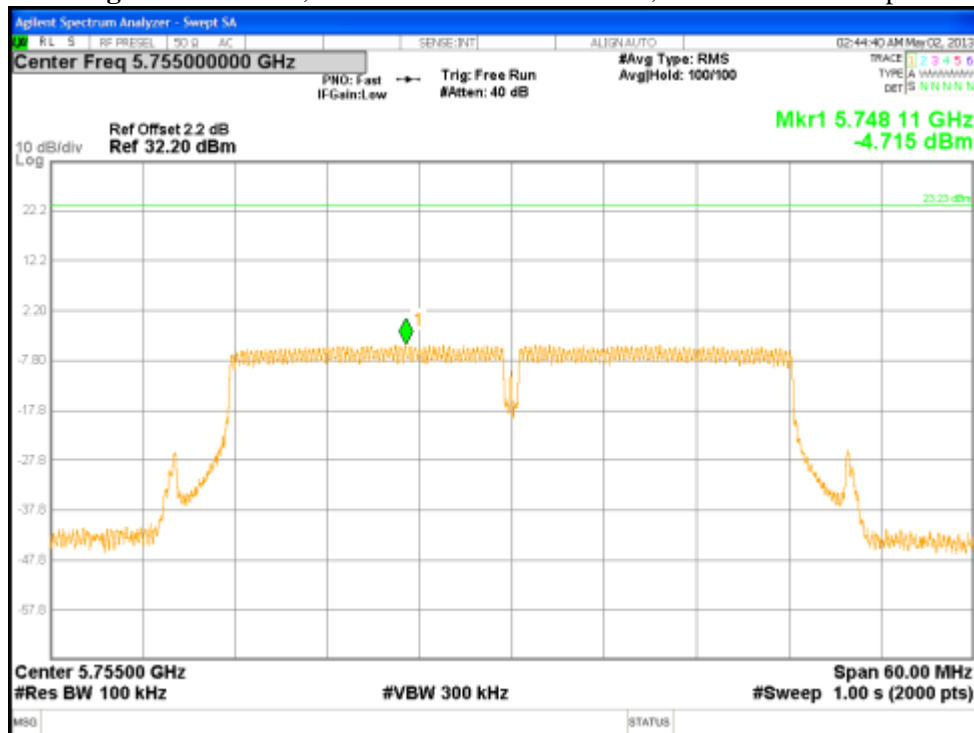

Figure 128: PPSD, 5755 MHz at 802.11n HT40, Chain 3 – 13.5 Mbps

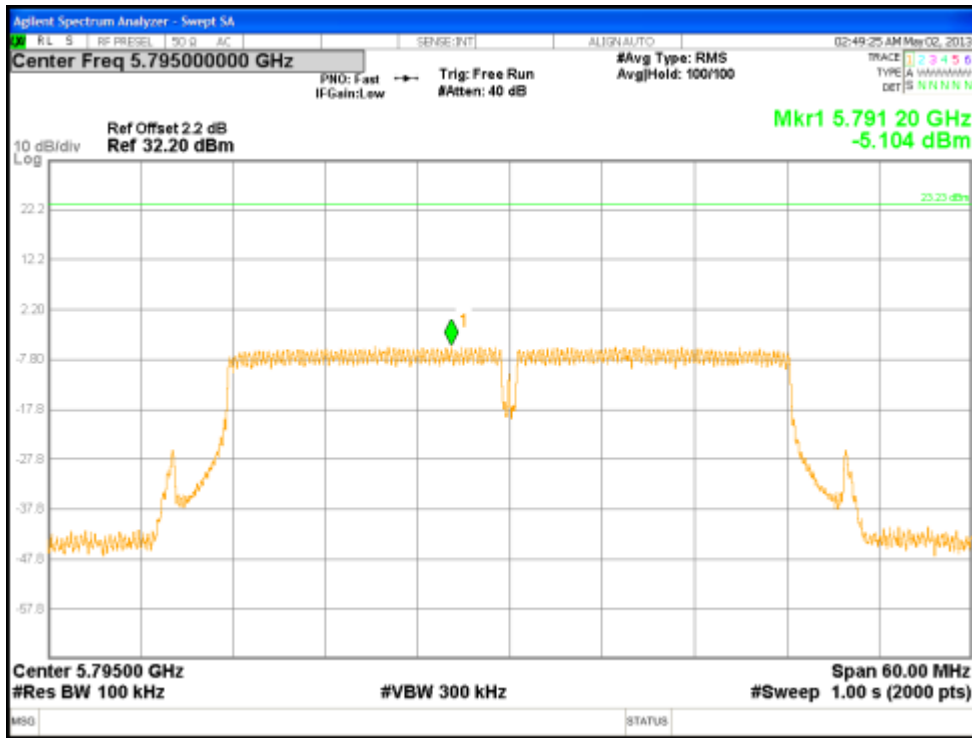

Figure 129: PPSD, 5795 MHz at 802.11n HT40, Chain 0 – 13.5 Mbps

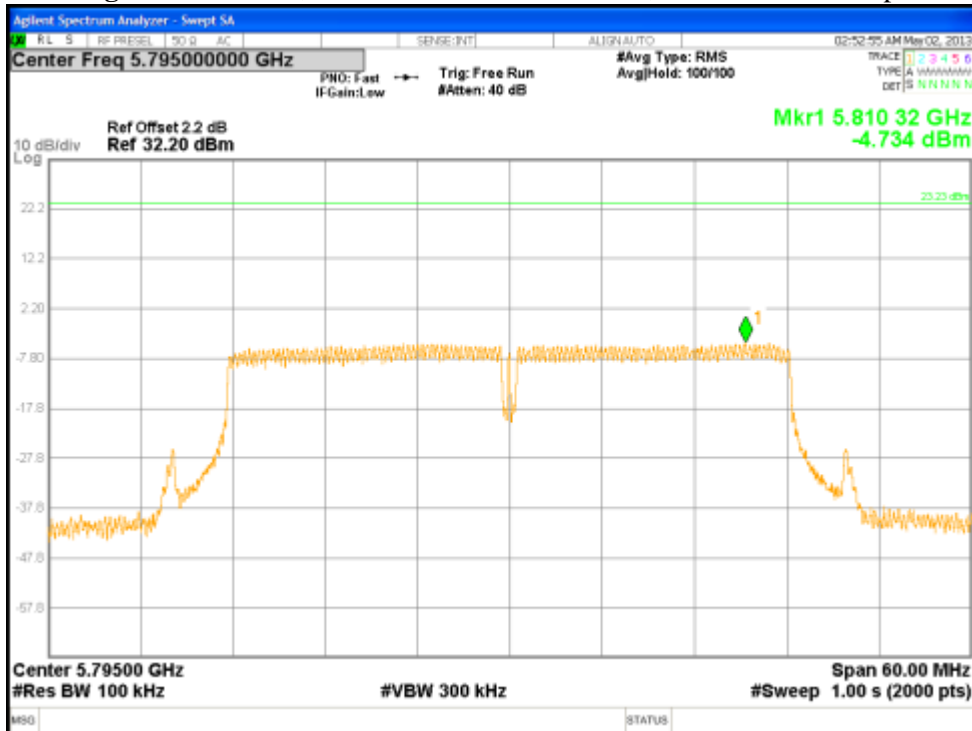

Figure 130: PPSD, 5795 MHz at 802.11n HT40, Chain 1 – 13.5 Mbps

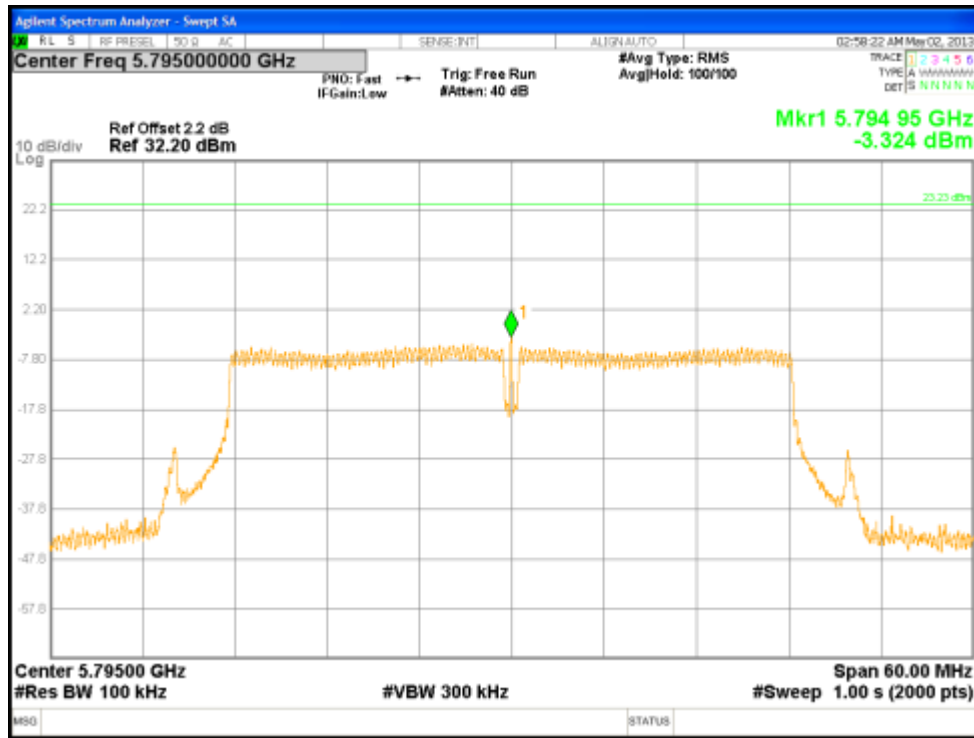

Figure 131: PPSD, 5795 MHz at 802.11n HT40, Chain 2 – 13.5 Mbps

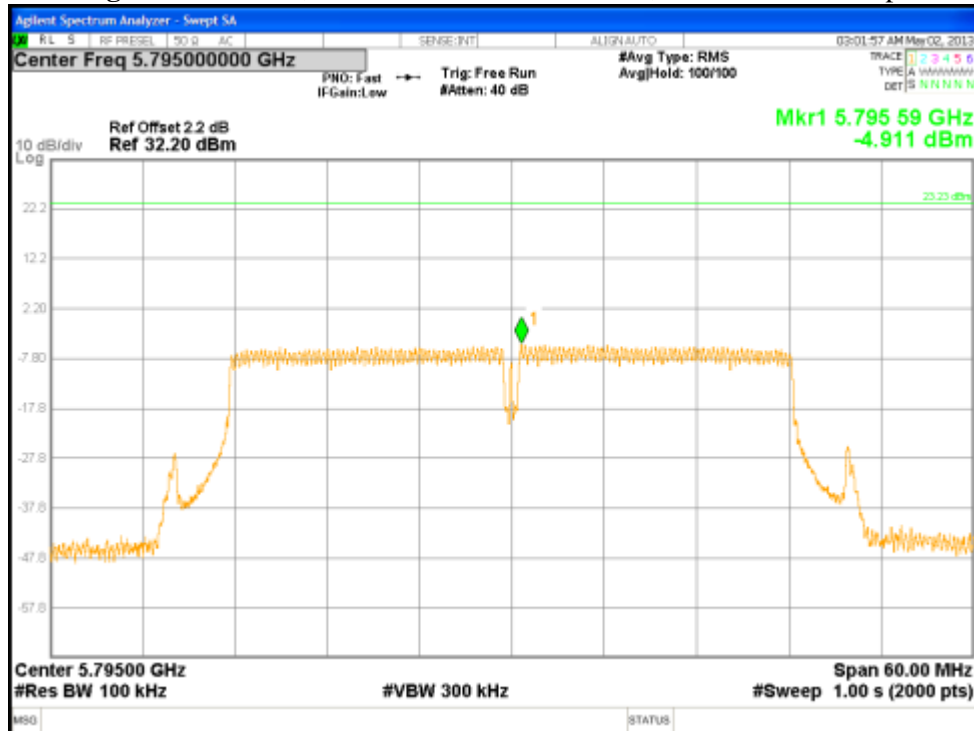

Figure 132: PPSD, 5795 MHz at 802.11n HT40, Chain 3 – 13.5 Mbps

4.5 Transmitter Spurious Emissions

Transmitter spurious emissions are emissions outside the frequency range of the equipment when the equipment is in transmit mode; per requirement of CFR47 15.205, 15.209, 15.407(b), RSS 210 Sect. A.9.2

4.5.1 Test Methodology

4.5.1.1 Preliminary Test

A test program that controls instrumentation and data logging was used to automate the preliminary RF emission test procedure. The frequency range of interest was divided into sub-ranges to yield a frequency resolution of approximately 120 kHz and provide a reading at each frequency for no more than 12° of turntable rotation. For each frequency sub-range the turntable was rotated 360° while peak emission data was recorded and plotted over the frequency range of interest in horizontal and vertical antenna polarization's.

Preliminary emission profile testing was performed inside the anechoic chamber. The EUT was placed on a 1.0m x 1.5m non-conductive table 80cm above the floor. The EUT was positioned as shown in the setup photographs. The receiving antenna was placed at a distance of 3m at a fixed height of 1m. Measurement equipment was located outside of the chamber. A video camera was placed inside the chamber to view the EUT.

Pres-scans were performed to determine the worst axis, data rate/ chains.

4.5.1.2 Final Test

For each frequency measured, the peak emission was maximized by manipulating the receiving antenna from 1 to 4 meters above the ground plane and placing it at the position that produced the maximum signal strength reading. The turntable was then rotated through 360° while observing the peak signal and placing the EUT at the position that produced maximum radiation. The six highest emissions relative to the limit were measured unless such emissions were more than 20 dB below the limit. If less than six emissions are within 20 dB of the limit, than the noise level of the receiver is measured at frequencies where emissions are expected. Multiples of all oscillator and microprocessor frequencies were also checked.

Final testing was performed on an NSA compliant test site. The EUT was placed on a 1.0m x 1.5m non-conductive table 80cm above the ground plane. The placement of EUT and cables were the same as for preliminary testing and is shown in the setup photographs.

The final scans performed on the worst axis, Y-Axis, for three operating channels;

6.5 Mbit/s for 802.11n HT20 Mode: 5745 MHz, 5785 MHz, 5825 MHz

13.5 Mbit/s for 802.11n HT40 Mode: 5755 MHz, 5795 MHz

4.5.1.3 Deviations

None.

4.5.2 Transmitter Spurious Emission Limit

The spurious emissions of the transmitter shall not exceed the values in CFR47 Part 15.205, 15.209: 2009 and RSS 210 A1.1.2 2007.

Frequency (MHz)	Field strength (microvolts/meter)	Measurement distance (meters)
0.009-0.490.....	2400/F (kHz)	300
0.490-1.705.....	24000/F (kHz)	30
1.705-30.0.....	30	30
30-88.....	100 **	3
88-216.....	150 **	3
216-960.....	200 **	3
Above 960.....	500	3

4.5.3 Test Results

The final measurement data was taken under the worst case operating modes, configurations, and/or cable positions. It also reflects the results including any modifications and/or special accessories listed in Sections 1.4 and test plan.

As originally tested, the EUT was found to be compliant to the requirements of the test standard(s).

Table 7: Transmit Spurious Emission at Band-Edge Requirements

Test Conditions: Radiated Measurement, Normal Temperature and Voltage only								
Antenna Type: Integrated					Power Setting: See test plan			
Max. Directional Gain: + 8 dBi					Signal State: Modulated at 100%.			
Ambient Temp.: 23 °C					Relative Humidity: 33%			
Band-Edge Results								
Freq. (MHz)	Level (dBuV/m)	Polarity (H/V)	Limit (dBuV/m)	Margin (dB)	Det.	Table Deg.	Tower (cm)	Note
5725.00	87.32	V	106.10	-18.78	Pk	234	173	HT20, 5745MHz, 22dBm
5725.00	69.57	V	84.35	-14.78	Ave	234	173	HT20, 5745MHz, 22dBm
5725.00	89.09	H	103.91	-14.82	Pk	265	179	HT20, 5745MHz, 22dBm
5725.00	69.69	H	82.29	-12.60	Ave	265	179	HT20, 5745MHz, 22dBm
5850.00	76.68	H	104.38	-27.70	Pk	262	179	HT20, 5825MHz, 22dBm
5850.00	58.07	H	82.31	-24.24	Ave	262	179	HT20, 5825MHz, 22dBm
5850.00	79.09	V	102.91	-23.82	Pk	272	216	HT20, 5825MHz, 22dBm
5850.00	62.21	V	80.77	-18.56	Ave	272	216	HT20, 5825MHz, 22dBm
5725.00	86.26	V	99.63	-13.37	Pk	324	177	HT40, 5755MHz, 22dBm
5725.00	61.23	V	77.56	-16.33	Ave	324	177	HT40, 5755MHz, 22dBm
5725.00	88.82	H	99.70	-10.88	Pk	261	171	HT40, 5755MHz, 22dBm
5725.00	64.62	H	78.14	-13.52	Ave	261	171	HT40, 5795MHz, 22dBm
5725.00	69.69	H	99.60	-29.91	Pk	270	174	HT40, 5755MHz, 22dBm
5725.00	54.37	H	77.73	-23.36	Ave	270	174	HT40, 5755MHz, 22dBm
5725.00	70.28	V	102.34	-32.06	Pk	246	168	HT40, 5755MHz, 22dBm
5725.00	55.14	V	80.12	-24.98	Ave	246	168	HT40, 5755MHz, 22dBm
<p>Note: 1. Band-edge frequencies were taken at 5725MHz or 5850 MHz. Since both sides of the operational band are not restricted, the measurements took to demonstrate the compliance to 20dB relative to peak.</p> <p>2. All the band-edge measurements met the restricted band requirements of CFR47 15.205 and 15.209.</p>								

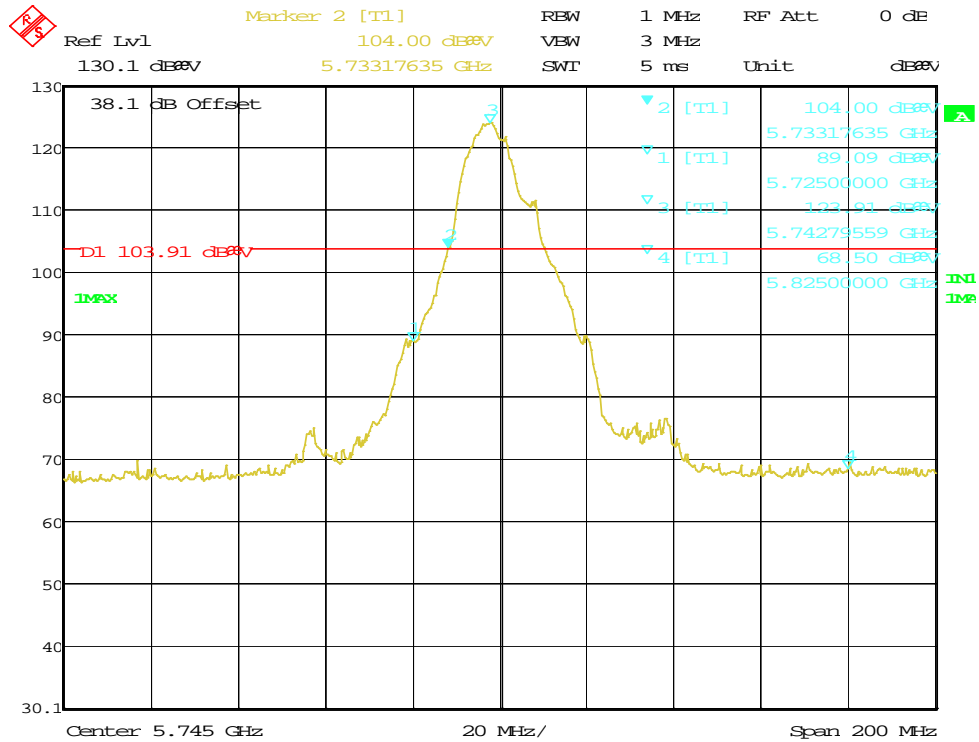

Date: 11.MAR.2013 14:09:37

Figure 133: Radiated Emission at the Edge for 5745 MHz – Horiz. (Pk)

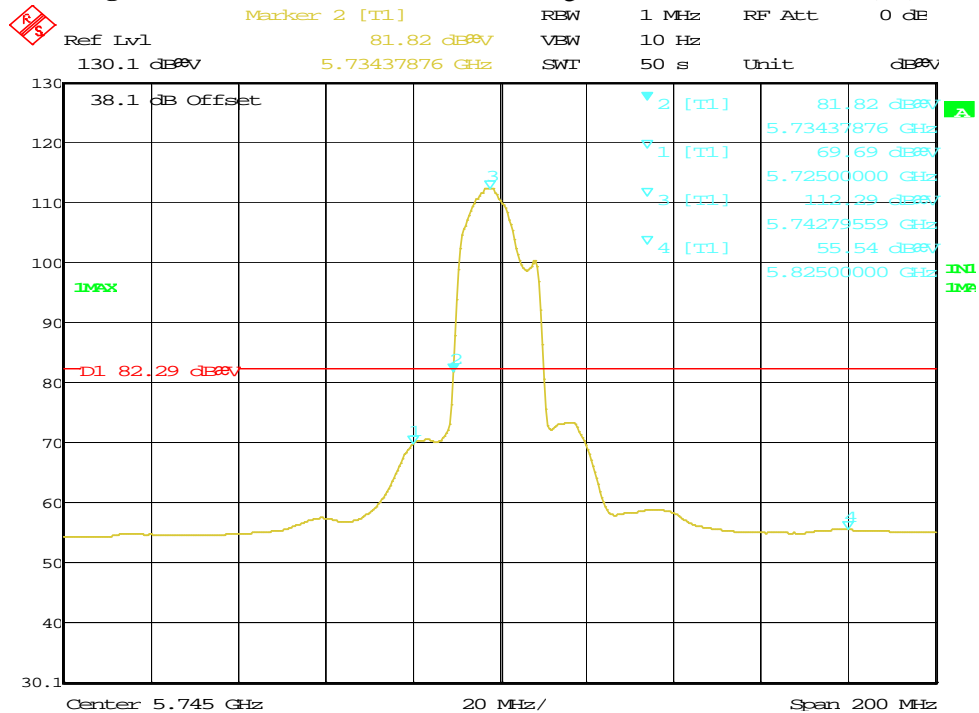

Date: 11.MAR.2013 14:10:57

Figure 134: Radiated Emission at the Edge for 5745 MHz – Horiz. (QP)

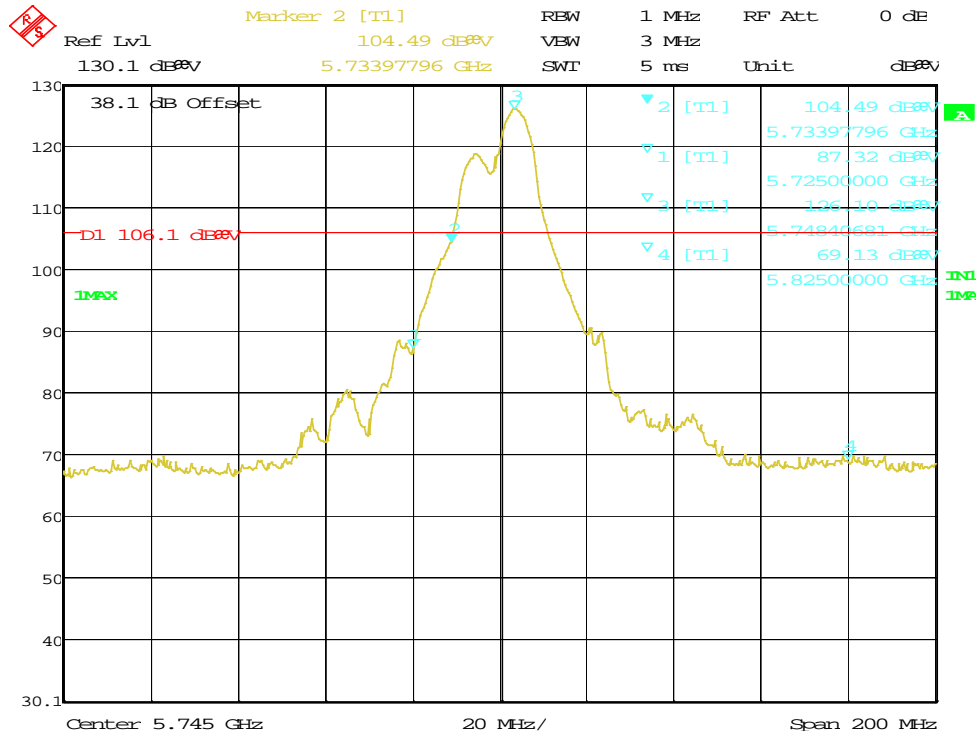

Date: 11.MAR.2013 14:03:52

Figure 135: Radiated Emission at the Edge for 5745 MHz – Vert. (Pk)

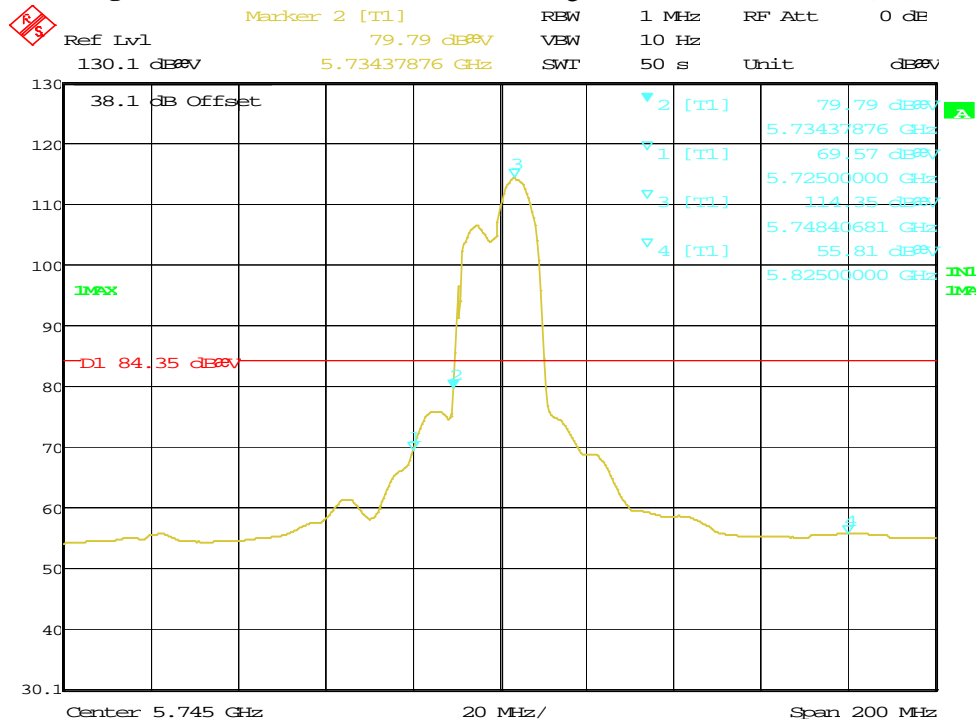

Date: 11.MAR.2013 14:06:19

Figure 136: Radiated Emission at the Edge for 5745 MHz – Vert. (QP)

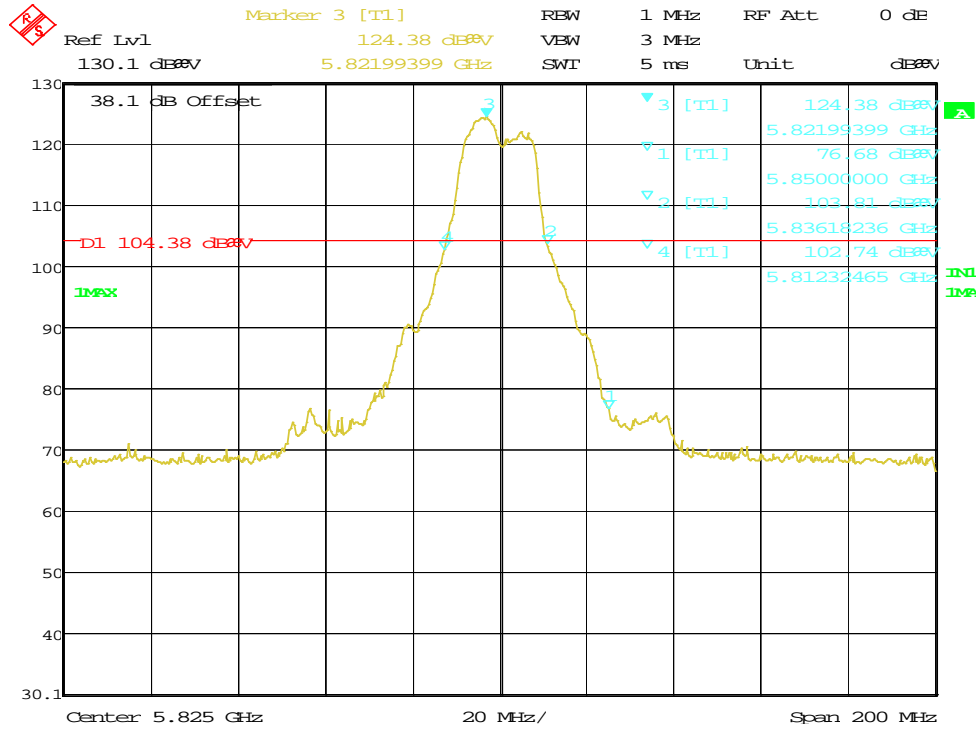

Date: 11.MAR.2013 14:20:19

Figure 137: Radiated Emission at the Edge for 5825 MHz – Horz. (Pk)

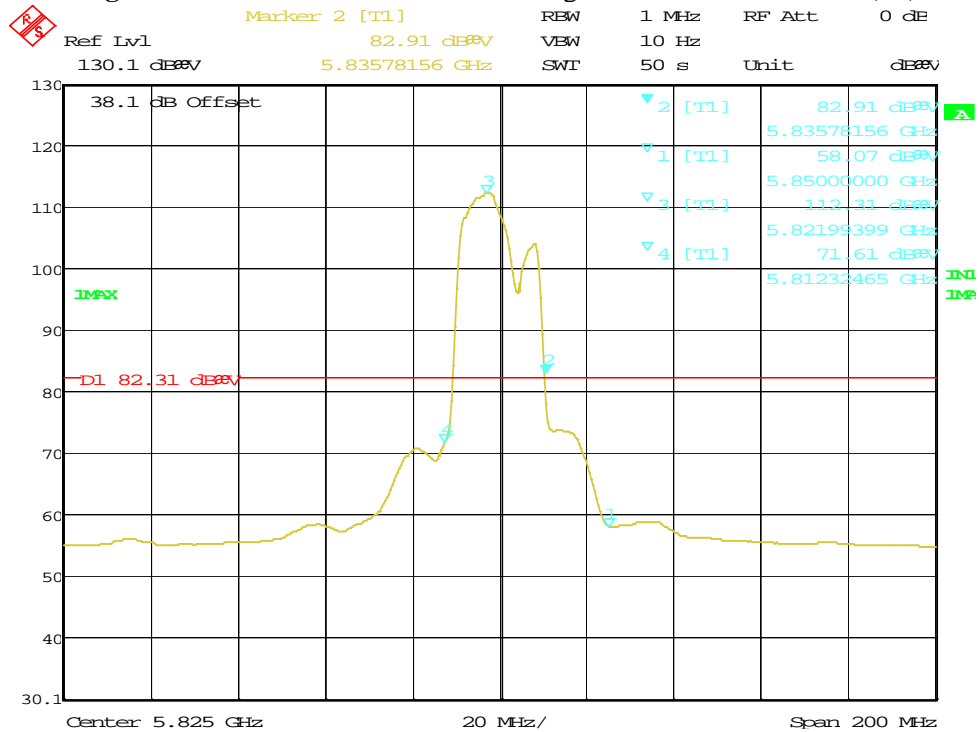

Date: 11.MAR.2013 14:22:05

Figure 138: Radiated Emission at the Edge for 5825 MHz – Horz. (QP)

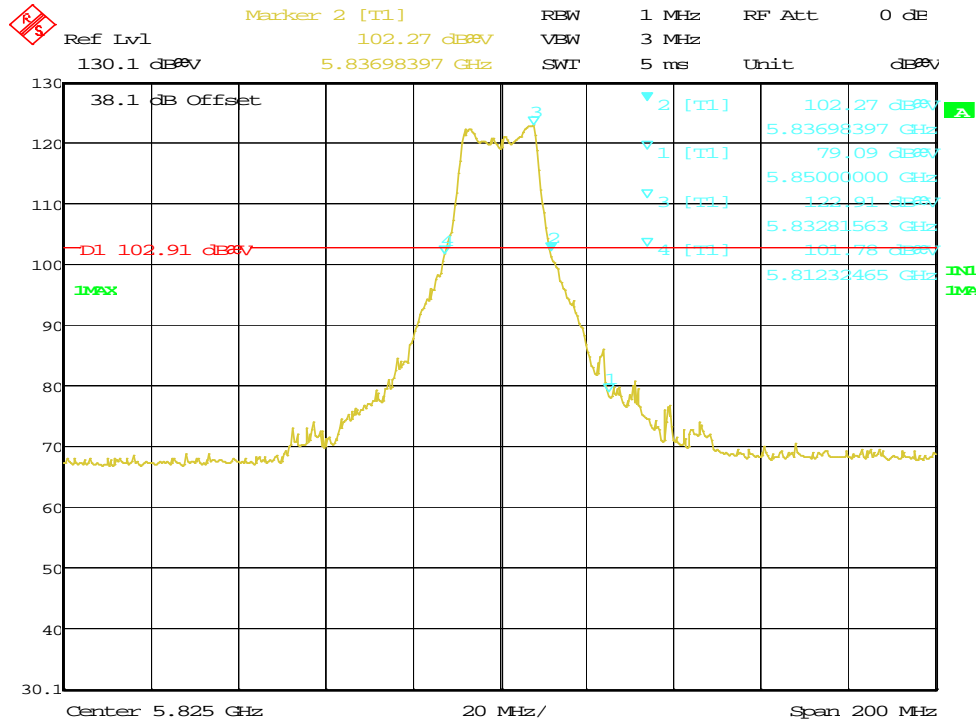

Date: 11.MAR.2013 14:25:26

Figure 139: Radiated Emission at the Edge for 5825 MHz – Vert. (Pk)

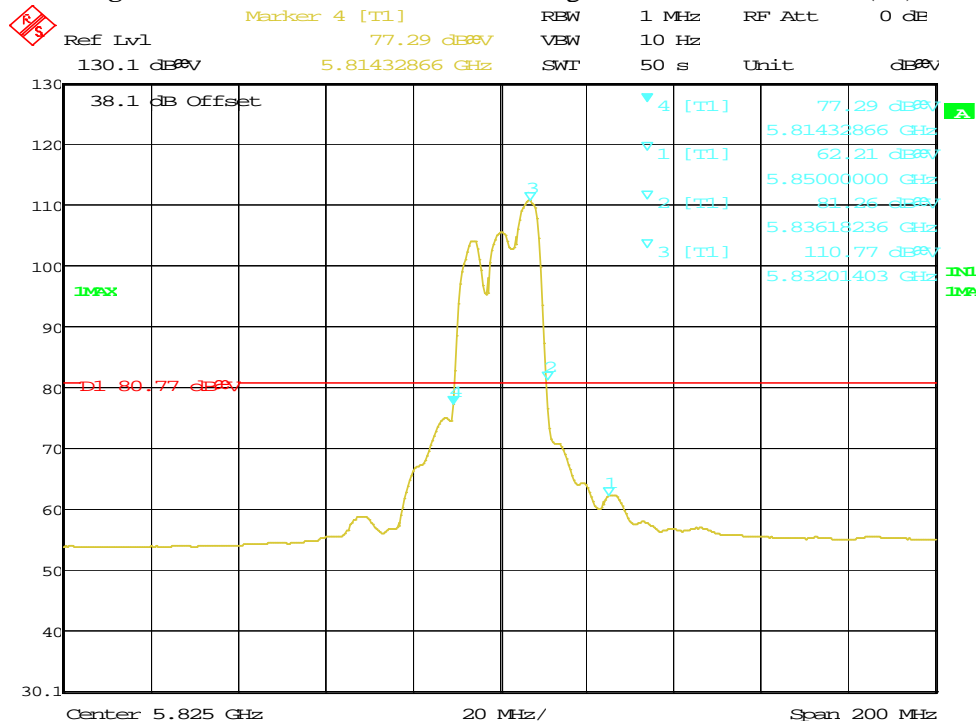

Date: 11.MAR.2013 14:27:02

Figure 140: Radiated Emission at the Edge for 5825 MHz – Vert. (QP)

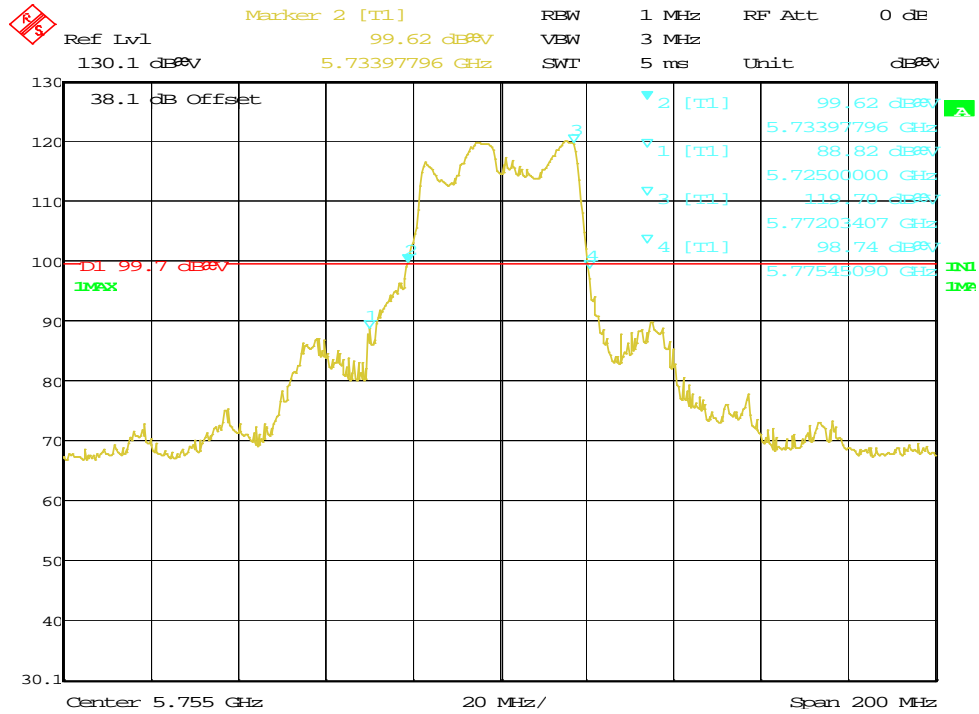

Date: 11.MAR.2013 14:37:19

Figure 141: Radiated Emission at the Edge for 5755 MHz – Horz. (Pk)

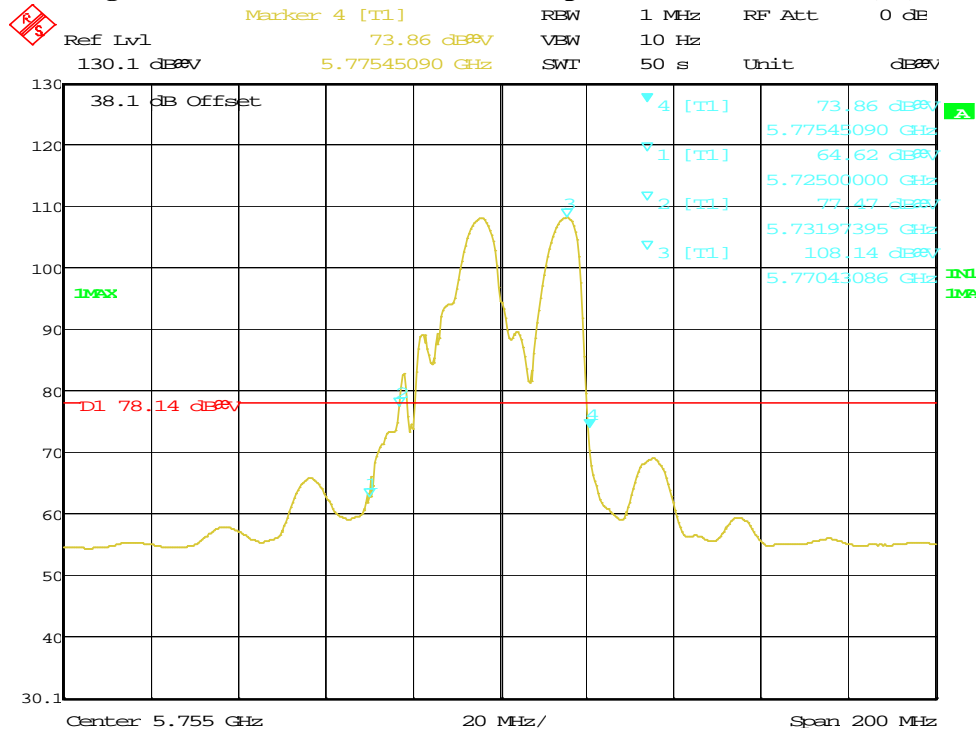

Date: 11.MAR.2013 14:38:52

Figure 142: Radiated Emission at the Edge for 5755 MHz – Horz. (QP)

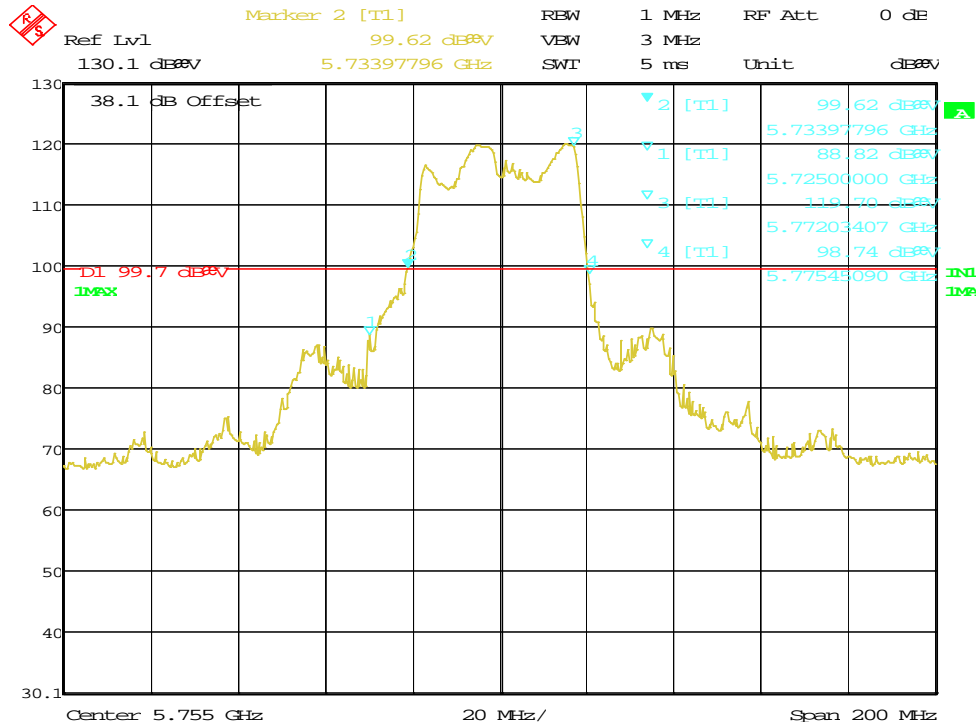

Date: 11.MAR.2013 14:37:19

Figure 143: Radiated Emission at the Edge for 5755 MHz – Vert. (Pk)

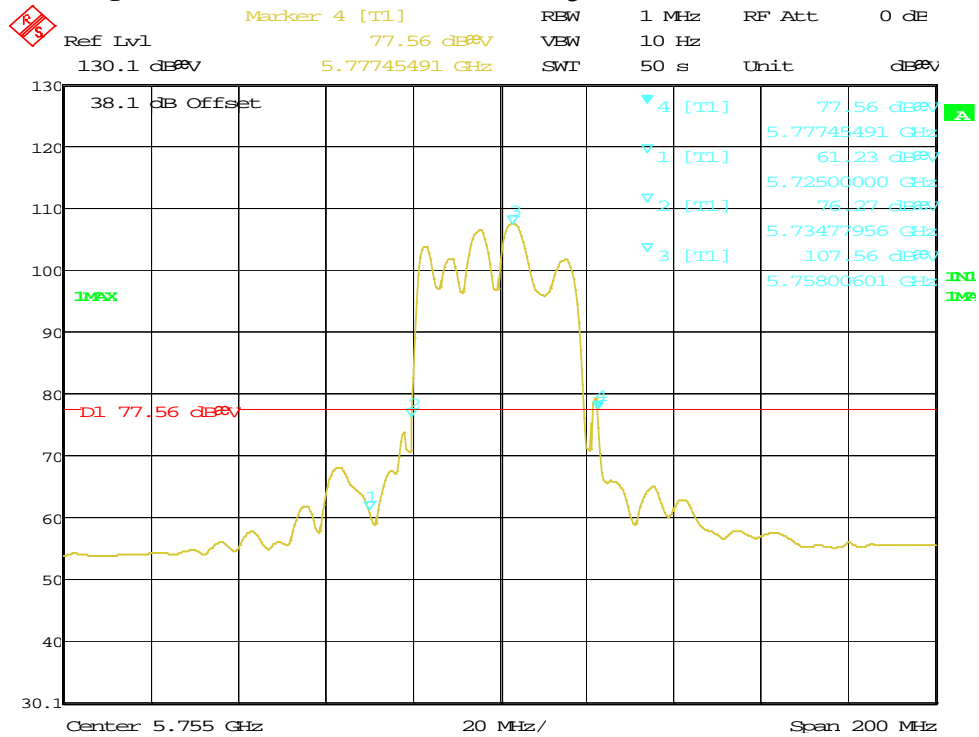

Date: 11.MAR.2013 14:34:06

Figure 144: Radiated Emission at the Edge for 5755 MHz – Vert. (QP)

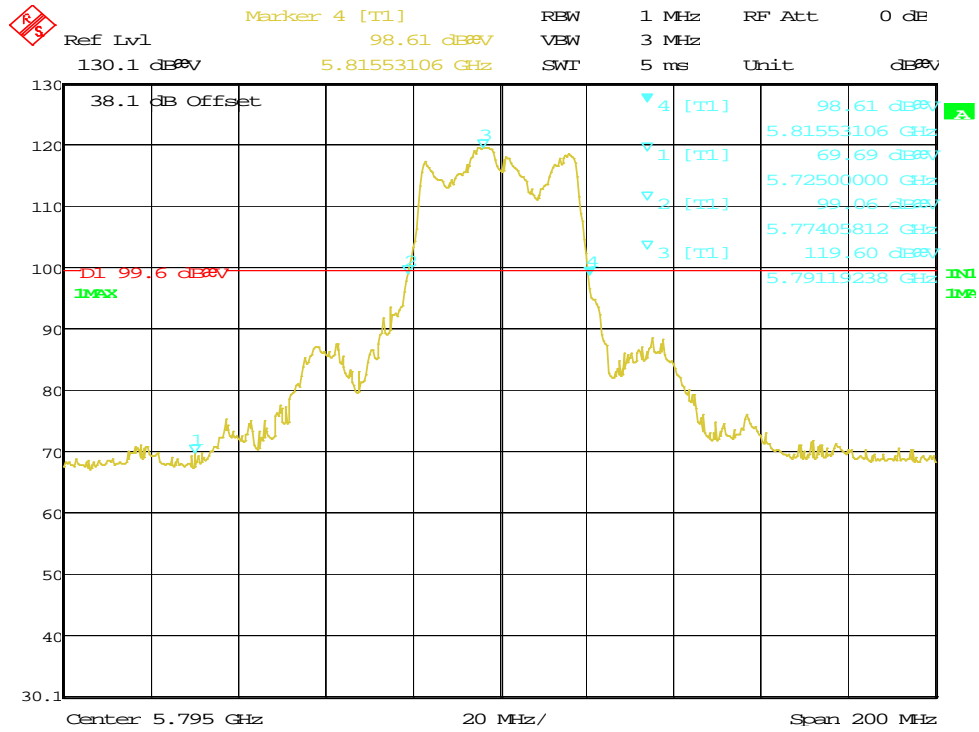

Date: 11.MAR.2013 14:45:10

Figure 145: Radiated Emission at the Edge for 5795 MHz – Horz. (Pk)

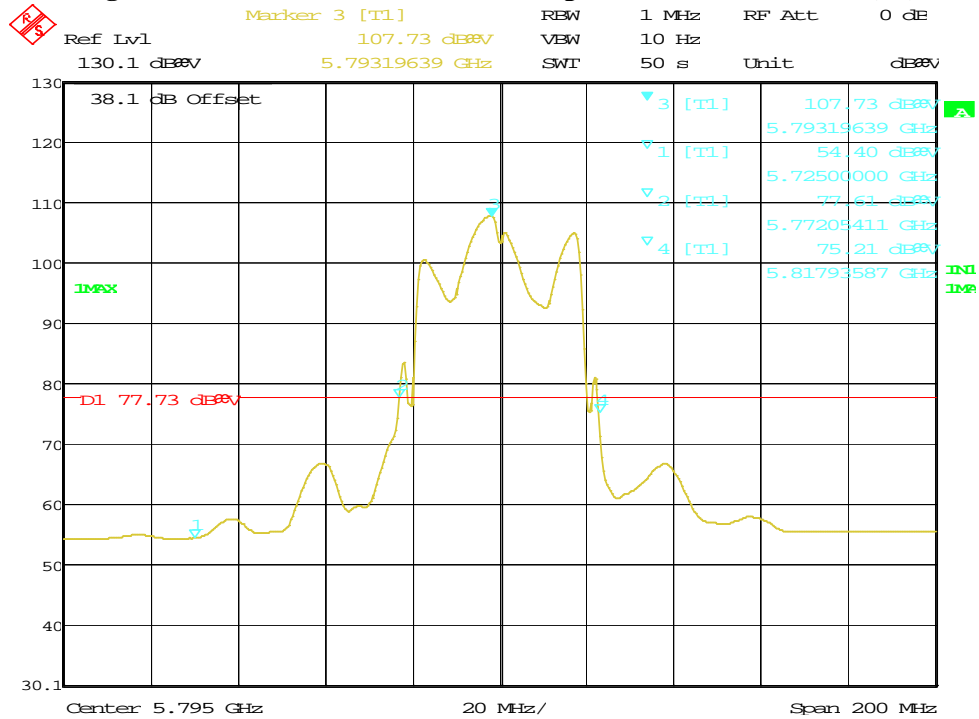

Date: 11.MAR.2013 14:46:24

Figure 146: Radiated Emission at the Edge for 5795 MHz – Horz. (QP)

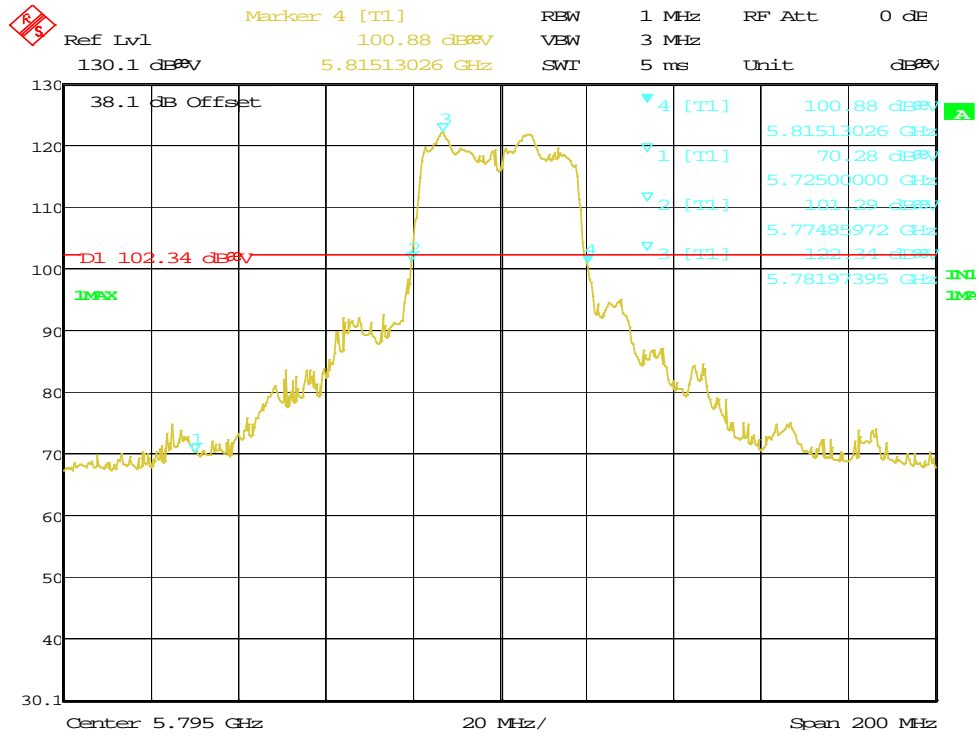

Date: 11.MAR.2013 14:49:30

Figure 147: Radiated Emission at the Edge for 5795 MHz – Vert. (Pk)

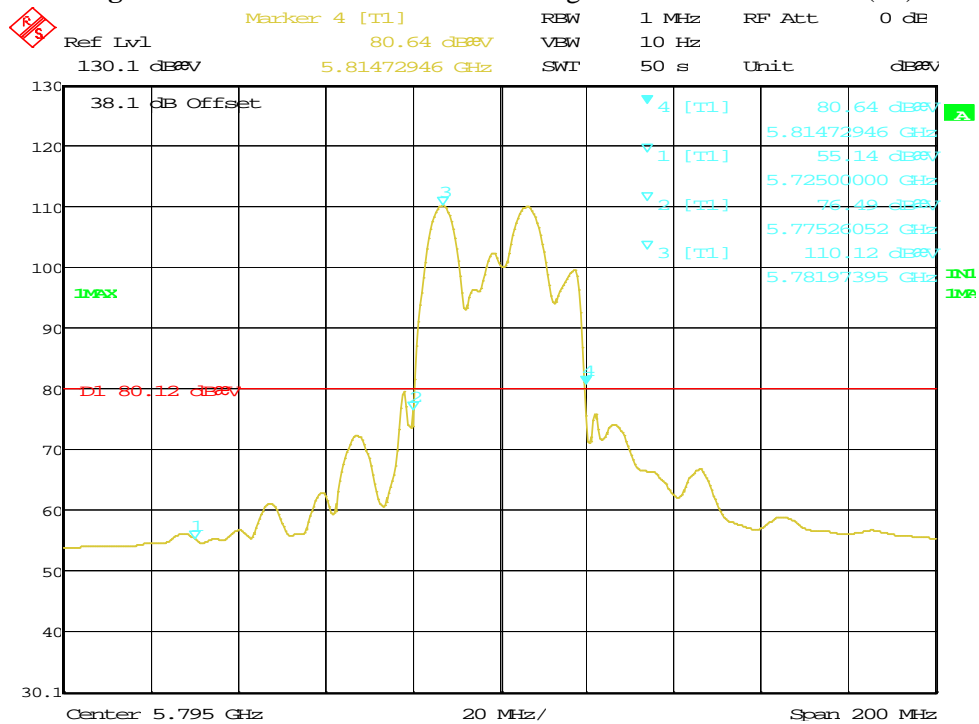

Date: 11.MAR.2013 14:50:51

Figure 148: Radiated Emission at the Edge for 5795 MHz – Vert. (QP)

SOP 1 Radiated Emissions						Tracking # 31360999.002 Page 1 of 15			
EUT Name			Wireless Video Access Point			Date		April 30, 2013	
EUT Model			405			Temp / Hum in		23°C / 28%rh	
EUT Serial			09130M000104			Temp / Hum out		N/A	
EUT Config.			Y-Axis, 802.11n HT20 at 6.5Mbps/ chain			Line AC / Freq		120Vac/60Hz	
Standard			CFR47 Part 15 Subpart C			RBW / VBW		120 kHz/ 300 kHz	
Dist/Ant Used			3m / JB3			Performed by		Jeremy Luong	
Emission Freq (MHz)	ANT Polar (H/V)	ANT Pos (cm)	Table Pos (deg)	FIM QP (dBuV/m)	Total CF (dBuV)	E-Field QP (dBuV/m)	Spec Limit (dBuV/m)	Spec Margin (dB)	Type
30 MHz to 1GHz Transmitted at 802.11n HT20, 5785 MHz 6.5Mbps/chain									
47.11	V	400	186	42.42	-17.19	25.24	40.00	-14.76	Spurious
65.83	V	149	352	57.44	-18.46	38.98	40.00	-1.02	Spurious
121.93	V	103	356	54.89	-11.99	42.90	43.50	-0.60	Spurious
141.91	V	103	206	52.93	-12.70	40.23	43.50	-3.27	Spurious
176.84	H	400	356	47.93	-13.97	33.96	43.50	-9.54	Spurious
237.35	V	139	46	56.50	-12.79	43.71	46.00	-2.29	Spurious
330.23	H	207	322	53.28	-9.95	43.33	46.00	-2.67	Spurious
574.99	V	400	262	36.36	-5.84	30.52	46.00	-15.48	Spurious
639.99	V	400	356	36.30	-4.75	31.55	46.00	-14.45	Spurious
Spec Margin = E-Field QP - Limit, E-Field QP = FIM QP+ Total CF ± Uncertainty									
Total CF= Amp Gain + Cable Loss + ANT Factor									
Combined Standard Uncertainty $u_c(y) = \pm 3.2$ dB Expanded Uncertainty $U = k u_c(y)$ $k = 2$ for 95% confidence									
Notes: Worst case was observed on Y-axis at 802.11n HT20, 5200 MHz 6.5Mbps.									
All radio related emissions passed Class B limit.									

SOP 1 Radiated Emissions

Tracking # 31360999.002 Page 2 of 15

EUT Name	Wireless Video Access Point	Date	April 30, 2013
EUT Model	405	Temp / Hum in	23°C / 28%rh
EUT Serial	09130M000104	Temp / Hum out	N/A
EUT Config.	Y-Axis, 802.11n HT20 at 6.5Mbps/ chain	Line AC	120Vac 60Hz
Standard	CFR47 Part 15 Subpart C	RBW / VBW	120 kHz / 300 kHz
Dist/Ant Used	3m – JB3	Performed by	Jeremy Luong

30 MHz to 1GHz Plots for Transmit Mode at 5785 MHz

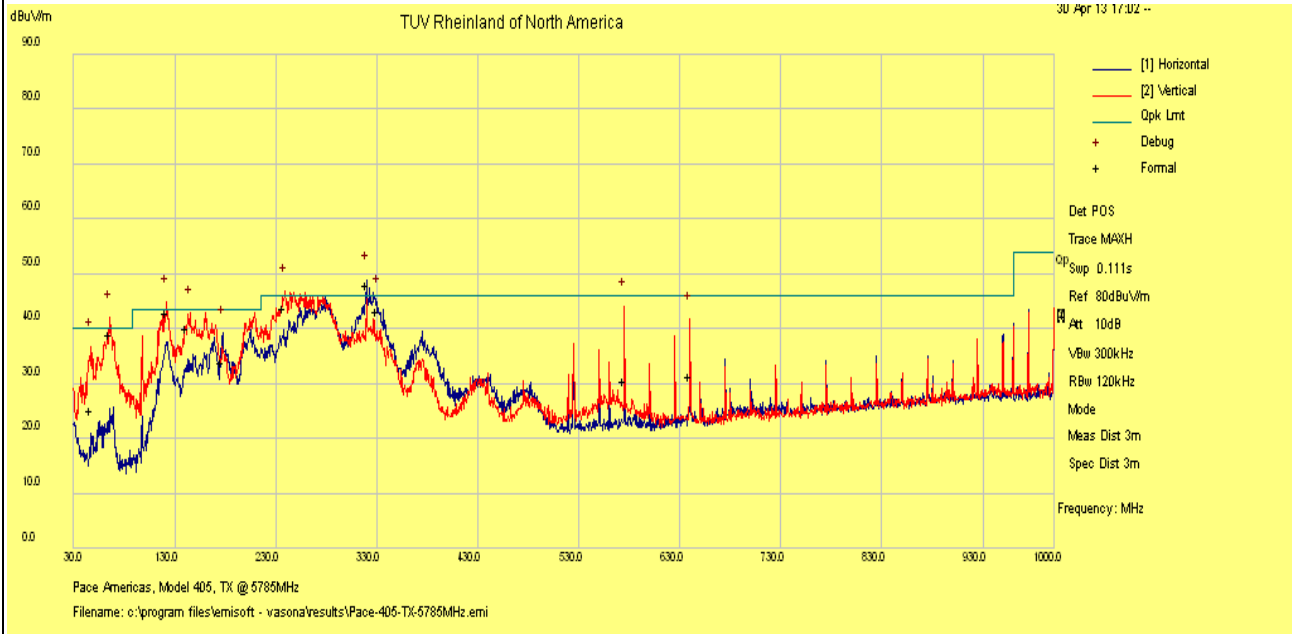

Notes: FCC Class B Limit. 320.00MHz emission was verified that it was not radio related. It was from digital circuitry.

SOP 1 Radiated Emissions				Tracking # 31360999.002 Page 3 of 15				
EUT Name	Wireless Video Access Point			Date	April 10, 2013			
EUT Model	405			Temp / Hum in	23°C / 33%rh			
EUT Serial	09130M000104			Temp / Hum out	N/A			
EUT Config.	Y-Axis, 802.11 HT20 at 6.5Mbps			Line AC / Freq	120Vac/60Hz			
Standard	CFR47 Part 15 Subpart C			RBW / VBW	1 MHz/ 3 MHz			
Dist/Ant Used	3m / EMCO3115 / 1m - RA42-K-F-4B-C			Performed by	Jeremy Luong			
Emission Freq (MHz)	ANT Polar (H/V)	ANT Pos (cm)	Table Pos (deg)	Peak (dBuV/m)	Average (dBuV/m)	Spec Limit (dBuV/m)	Spec Margin (dB)	Type
Transmitted Data at 5745 MHz @ 22 dBm								
1279.95	H	101	65	48.12	44.02	53.98	-9.96	Spurious
5577.35	V	171	173	63.16	51.48	53.98	-2.50	Spurious
5578.73	H	319	268	62.11	50.51	53.98	-3.47	Spurious
5981.63	H	350	269	60.26	48.82	53.98	-5.16	Spurious
5985.09	V	230	-33	60.00	51.03	53.98	-2.95	Spurious
7659.94	V	229	314	50.59	46.01	53.98	-7.97	Spurious
11486.10	H	240	77	62.89	49.78	53.98	-4.20	Harmonics
11487.10	V	272	69	62.84	49.81	53.98	-4.17	Harmonics
22969.90	V	99	32	74.10	59.13	64.00	-4.87	Harmonics
22979.80	H	114	107	68.98	61.90	64.00	-2.10	Harmonics
Transmitted Data at 5785 MHz @ 22 dBm								
1279.96	H	261	58	46.28	41.89	53.98	-12.09	Spurious
2428.05	V	280	-48	44.96	40.15	53.98	-13.83	Spurious
5058.90	H	261	255	58.82	46.71	53.98	-7.27	Spurious
5545.16	V	177	234	62.96	52.61	53.98	-1.37	Spurious
6025.01	V	213	155	59.52	50.99	53.98	-2.99	Spurious
7713.29	V	212	237	53.44	45.48	53.98	-8.50	Spurious
11568.90	V	107	50	65.35	52.79	53.98	-1.19	Harmonics
11569.80	H	136	414	63.99	51.73	53.98	-2.25	Harmonics
23147.00	V	93	477	69.16	56.73	64.00	-7.27	Harmonics
23139.90	H	99	95	63.33	58.46	64.00	-5.54	Harmonics
28924.80	V	101	163	52.72	45.22	64.00	-18.78	Harmonics
Transmitted Data at 5825 MHz @ 22 dBm								
1280.03	H	100	423	48.13	44.53	53.98	-9.45	Spurious
5061.87	H	269	274	59.73	47.23	53.98	-6.75	Spurious
5564.25	V	205	143	61.20	49.97	53.98	-4.01	Spurious
6041.64	V	246	302	61.63	51.63	53.98	-2.35	Spurious
7739.95	V	213	-23	50.66	43.14	53.98	-10.84	Spurious
11609.80	V	122	480	64.12	51.46	53.98	-2.52	Harmonics
11609.90	H	129	50	63.75	51.44	53.98	-2.54	Harmonics
23291.40	H	97	46	69.76	55.93	64.00	-8.07	Harmonics
23299.50	V	96	32	72.78	60.58	64.00	-3.42	Harmonics

Spec Margin = E-Field Average - Limit, E-Field Average = Field Meas.+ Total CF \pm Uncertainty
Total CF= Amp Gain + Cable Loss + ANT Factor
Combined Standard Uncertainty $u_c(y) = \pm 3.2$ dB Expanded Uncertainty $U = ku_c(y)$ $k = 2$ for 95% confidence
Notes: Worst case was observed on Y-axis, 6.5Mbps.

SOP 1 Radiated Emissions				Tracking # 31360999.002 Page 4 of 15				
EUT Name	Wireless Video Access Point			Date	April 10, 2013			
EUT Model	405			Temp / Hum in	23°C / 33%rh			
EUT Serial	09130M000104			Temp / Hum out	N/A			
EUT Config.	Y-Axis, 802.11 HT40 at 13.5Mbps			Line AC / Freq	120Vac/60Hz			
Standard	CFR47 Part 15 Subpart C			RBW / VBW	1 MHz/ 3 MHz			
Dist/Ant Used	3m / EMCO3115 / 1m - RA42-K-F-4B-C			Performed by	Jeremy Luong			
Emission Freq (MHz)	ANT Polar (H/V)	ANT Pos (cm)	Table Pos (deg)	Peak (dBuV/m)	Average (dBuV/m)	Spec Limit (dBuV/m)	Spec Margin (dB)	Type
Transmitted Data at 5755 MHz @ 22 dBm								
1279.91	H	105	292	50.76	46.90	53.98	-7.08	Spurious
5016.72	H	224	270	54.81	43.29	53.98	-10.69	Spurious
5039.90	V	179	123	53.38	42.05	53.98	-11.93	Spurious
5578.93	V	176	243	63.82	51.48	53.98	-2.50	Spurious
5985.24	V	131	191	59.34	48.48	53.98	-5.50	Spurious
7673.25	V	212	228	54.26	46.80	53.98	-7.18	Spurious
11507.40	V	108	418	61.82	51.81	53.98	-2.17	Harmonics
11510.10	H	142	71	60.64	50.86	53.98	-3.12	Harmonics
23029.70	V	97	31	65.20	57.52	64.00	-6.48	Harmonics
23019.80	H	99	100	64.82	60.51	64.00	-3.49	Harmonics
Transmitted Data at 5795 MHz @ 22 dBm								
5039.92	V	144	274	57.71	48.99	53.98	-4.99	Spurious
5554.96	V	141	236	62.66	51.90	53.98	-2.08	Spurious
6025.23	V	127	191	61.54	49.52	53.98	-4.46	Spurious
7726.54	V	107	221	53.41	44.14	53.98	-9.84	Spurious
11589.80	V	100	45	62.76	52.61	53.98	-1.37	Harmonics
11589.80	H	97	150	61.31	51.27	53.98	-2.71	Harmonics
23169.50	V	100	36	65.84	57.73	64.00	-6.27	Harmonics
23179.80	H	100	32	62.97	59.45	64.00	-4.55	Harmonics
Spec Margin = E-Field Average - Limit, E-Field Average = Field Meas.+ Total CF ± Uncertainty								
Total CF= Amp Gain + Cable Loss + ANT Factor								
Combined Standard Uncertainty $u_c(y) = \pm 3.2$ dB Expanded Uncertainty $U = ku_c(y)$ $k = 2$ for 95% confidence								
Notes: Worst case was observed on Y-axis, 13.5Mbps.								

SOP 1 Radiated Emissions

Tracking # 31360999.002 Page 6 of 15

EUT Name	Wireless Video Access Point	Date	April 10, 2013
EUT Model	405	Temp / Hum in	23°C / 33%rh
EUT Serial	09130M000104	Temp / Hum out	N/A
EUT Config.	Y-Axis, 802.11n HT20 at 6.5Mbps	Line AC	120Vac 60Hz
Standard	CFR47 Part 15 Subpart C	RBW / VBW	1 MHz / 3MHz
Dist/Ant Used	3m - EMCO3115 / 1m - RA42-K-F-4B-C	Performed by	Jeremy Luong

Above 1GHz Plots for Transmit Mode at 5745 MHz

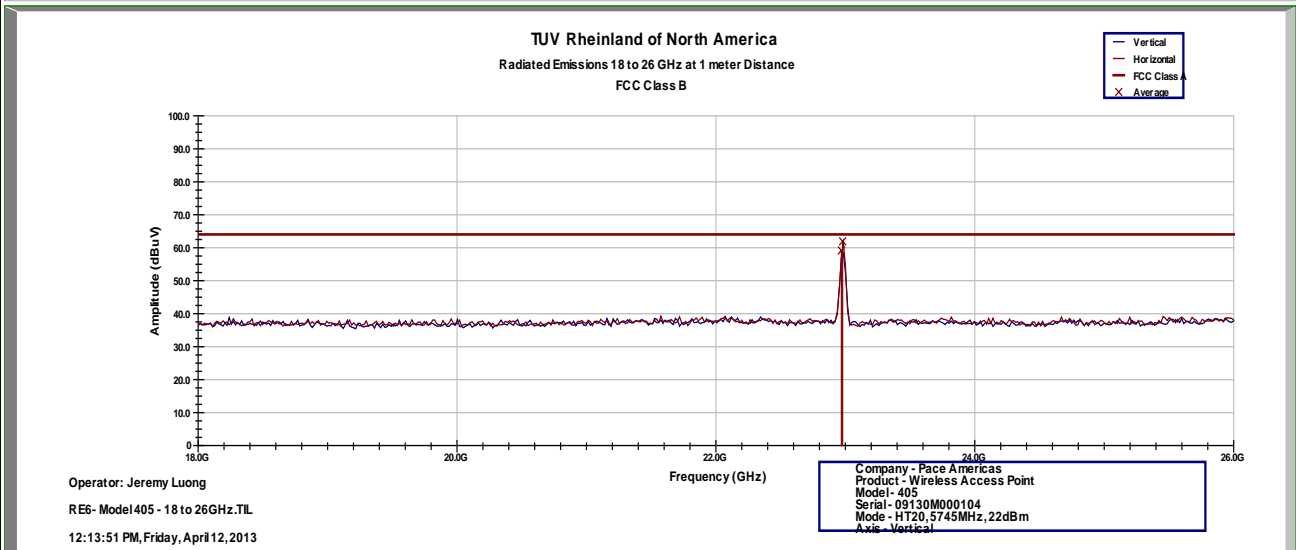
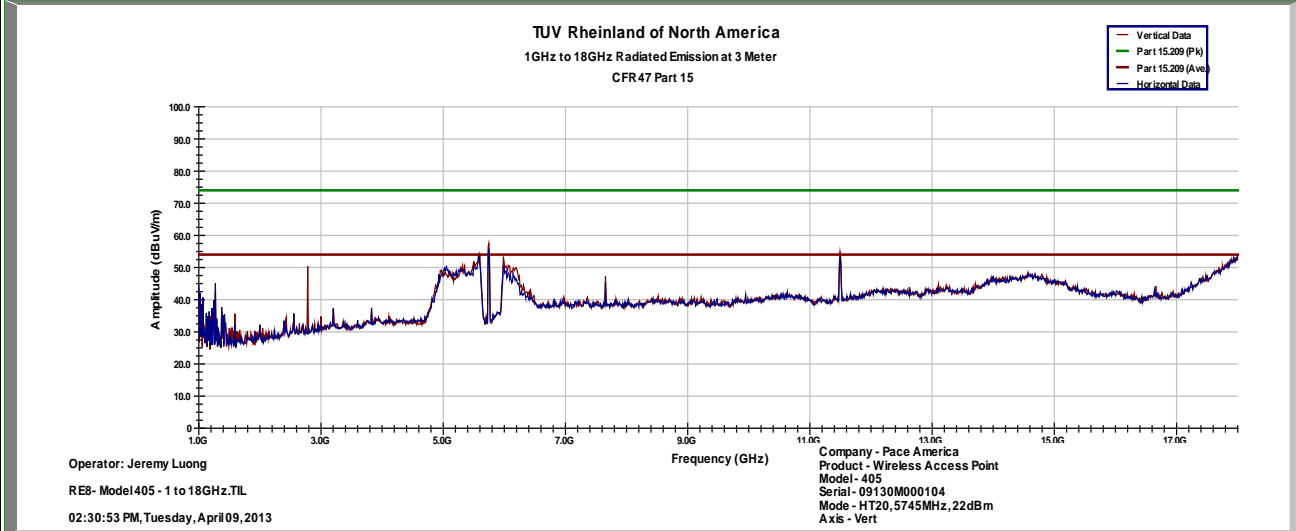

Notes: Limit was extrapolated to 1m distance for 18GHz – 40 GHz range.

SOP 1 Radiated Emissions

Tracking # 31360999.002 Page 7 of 15

EUT Name	Wireless Video Access Point	Date	April 10, 2013
EUT Model	405	Temp / Hum in	23°C / 33%rh
EUT Serial	09130M000104	Temp / Hum out	N/A
EUT Config.	Y-Axis, 802.11n HT20 at 6.5Mbps	Line AC	120Vac 60Hz
Standard	CFR47 Part 15 Subpart C	RBW / VBW	1 MHz / 3MHz
Dist/Ant Used	1m - RA42-K-F-4B-C	Performed by	Jeremy Luong

Above 1GHz Plots for Transmit Mode at 5745 MHz

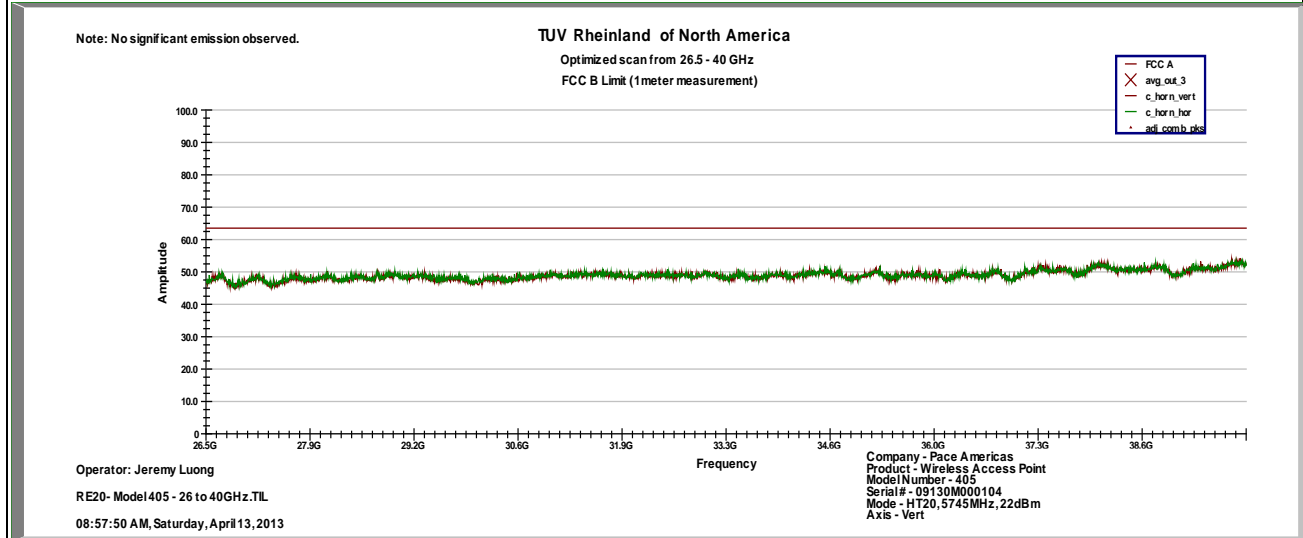

Notes: Limit was extrapolated to 1m distance for 18GHz – 40 GHz range.

SOP 1 Radiated Emissions

Tracking # 31360999.002 Page 8 of 15

EUT Name	Wireless Video Access Point	Date	April 10, 2013
EUT Model	405	Temp / Hum in	23°C / 33%rh
EUT Serial	09130M000104	Temp / Hum out	N/A
EUT Config.	Y-Axis, 802.11n HT20 at 6.5Mbps	Line AC	120Vac 60Hz
Standard	CFR47 Part 15 Subpart C	RBW / VBW	1 MHz / 3MHz
Dist/Ant Used	3m - EMCO3115 / 1m - RA42-K-F-4B-C	Performed by	Jeremy Luong

Above 1GHz Plots for Transmit Mode at 5785 MHz

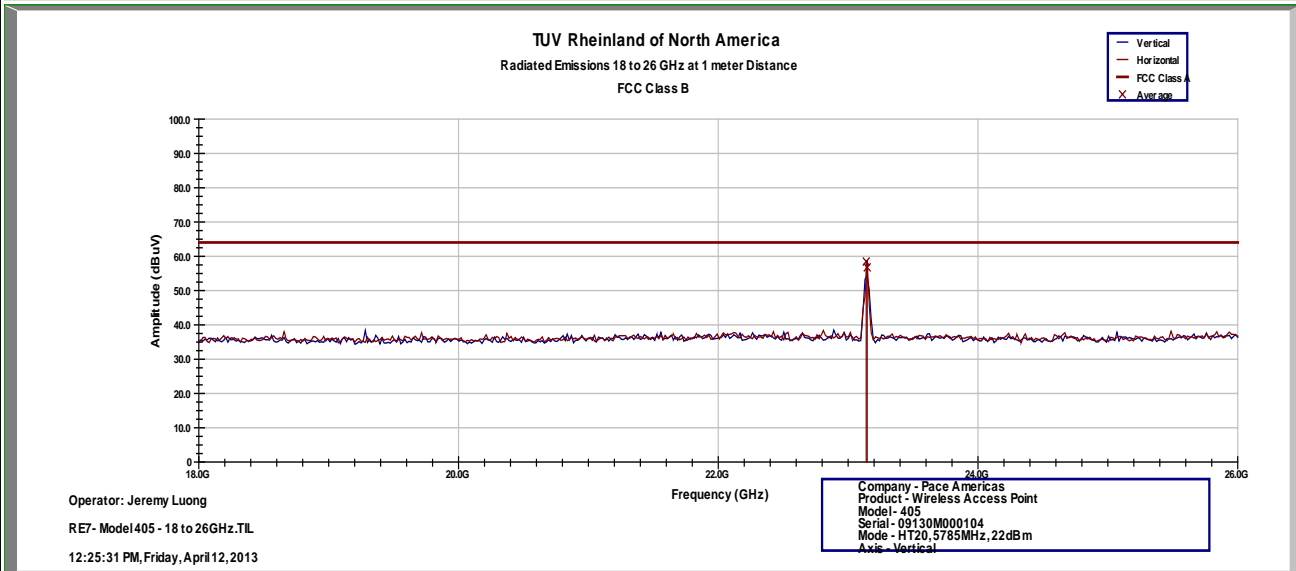
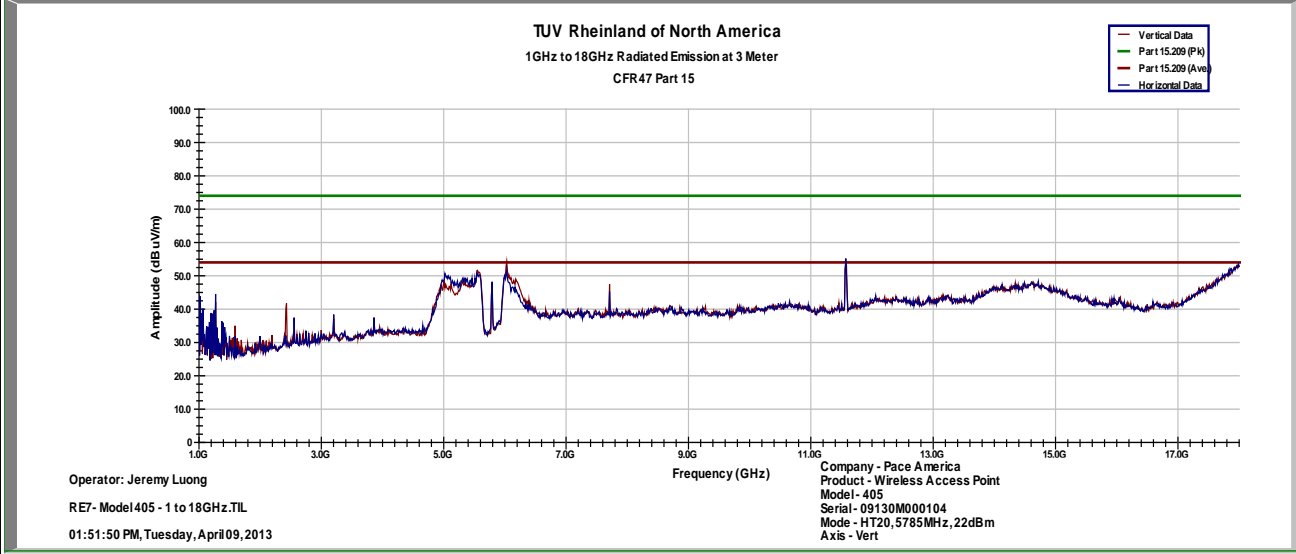

Notes: Limit was extrapolated to 1m distance for 18GHz – 40 GHz range.

SOP 1 Radiated Emissions

Tracking # 31360999.002 Page 9 of 15

EUT Name	Wireless Video Access Point	Date	April 10, 2013
EUT Model	405	Temp / Hum in	23°C / 33%rh
EUT Serial	09130M000104	Temp / Hum out	N/A
EUT Config.	Y-Axis, 802.11n HT20 at 6.5Mbps	Line AC	120Vac 60Hz
Standard	CFR47 Part 15 Subpart C	RBW / VBW	1 MHz / 3MHz
Dist/Ant Used	1m - RA42-K-F-4B-C	Performed by	Jeremy Luong

Above 1GHz Plots for Transmit Mode at 5785 MHz

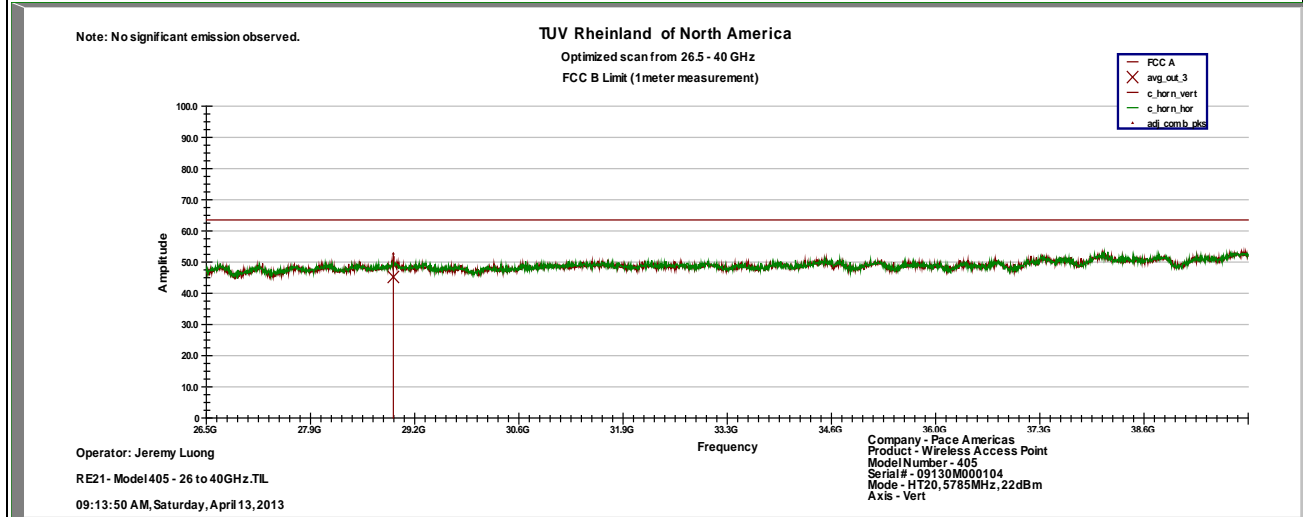

Notes: Limit was extrapolated to 1m distance for 18GHz – 40 GHz range.

SOP 1 Radiated Emissions

Tracking # 31360999.002 Page 10 of 15

EUT Name	Wireless Video Access Point	Date	April 10, 2013
EUT Model	405	Temp / Hum in	23°C / 33%rh
EUT Serial	09130M000104	Temp / Hum out	N/A
EUT Config.	Y-Axis, 802.11n HT20 at 6.5Mbps	Line AC	120Vac 60Hz
Standard	CFR47 Part 15 Subpart C	RBW / VBW	1 MHz / 3MHz
Dist/Ant Used	3m - EMCO3115 / 1m - RA42-K-F-4B-C	Performed by	Jeremy Luong

Above 1GHz Plots for Transmit Mode at 5825 MHz

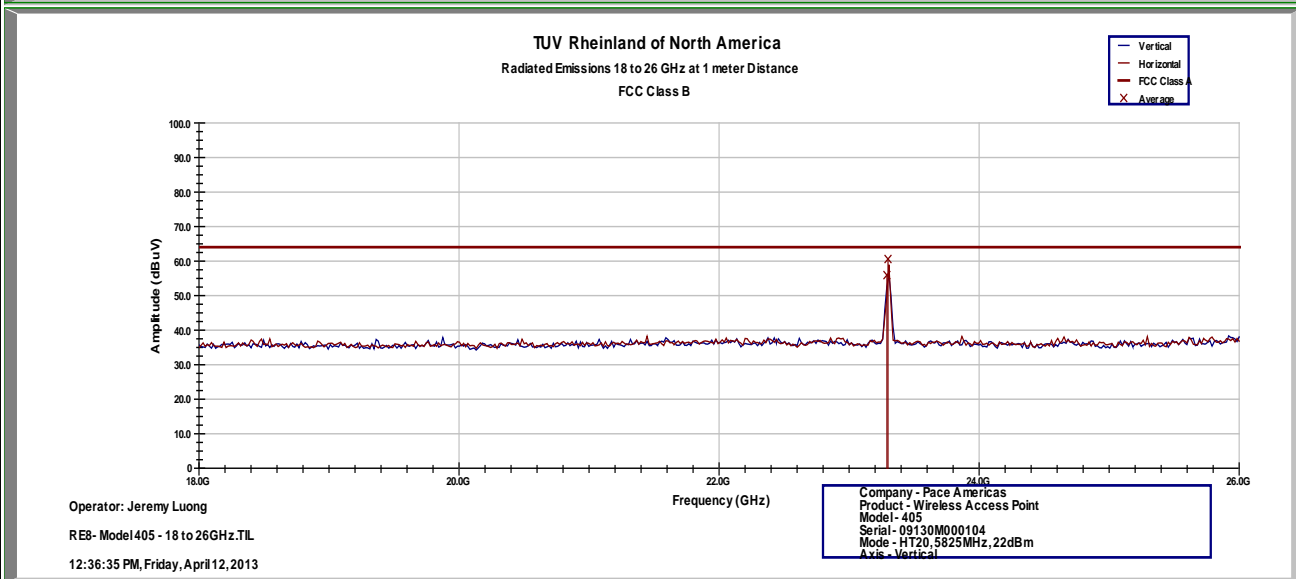
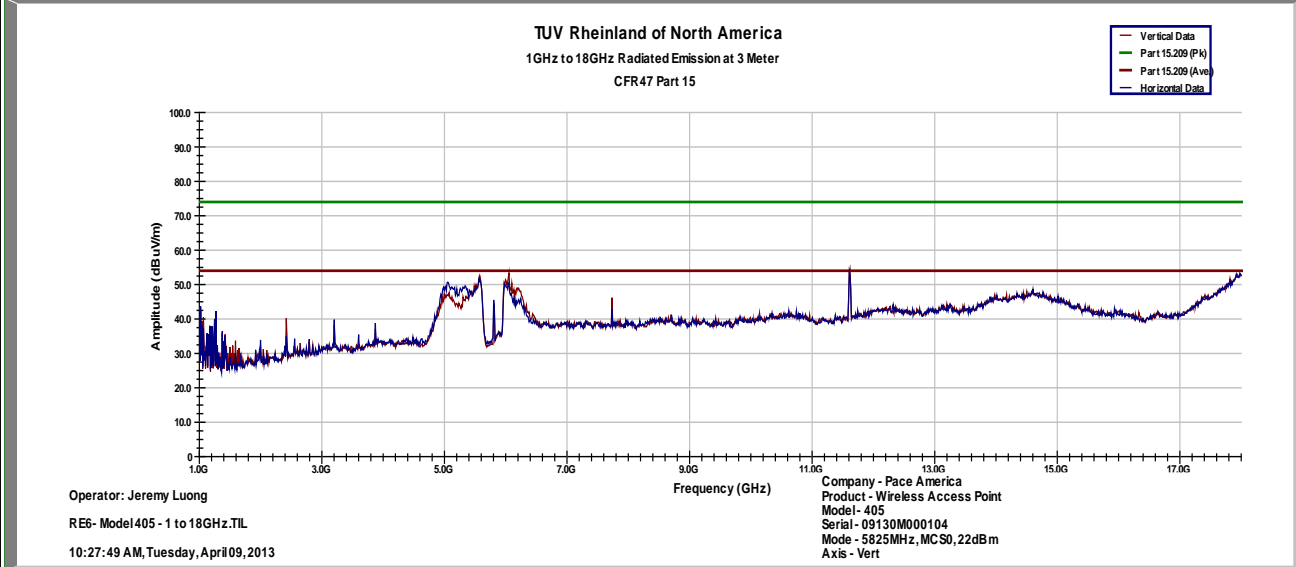

Notes: Limit was extrapolated to 1m distance for 18GHz – 40 GHz range.

SOP 1 Radiated Emissions

Tracking # 31360999.002 Page 11 of 15

EUT Name	Wireless Video Access Point	Date	April 10, 2013
EUT Model	405	Temp / Hum in	23°C / 33%rh
EUT Serial	09130M000104	Temp / Hum out	N/A
EUT Config.	Y-Axis, 802.11n HT20 at 6.5Mbps	Line AC	120Vac 60Hz
Standard	CFR47 Part 15 Subpart C	RBW / VBW	1 MHz / 3MHz
Dist/Ant Used	1m - RA42-K-F-4B-C	Performed by	Jeremy Luong

Above 1GHz Plots for Transmit Mode at 5825 MHz

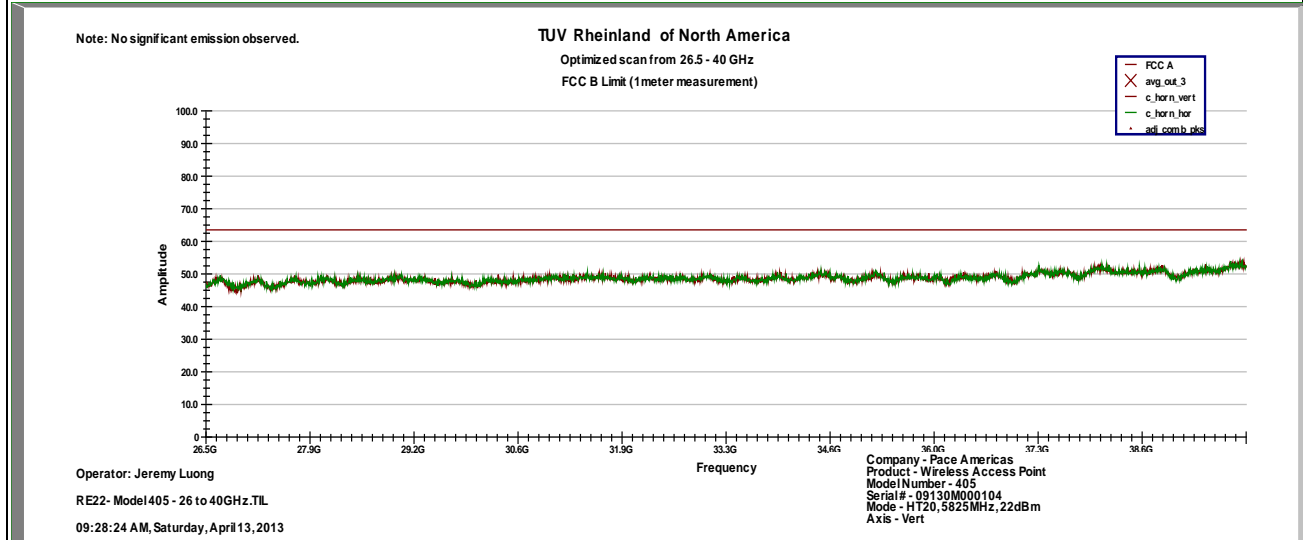

Notes: Limit was extrapolated to 1m distance for 18GHz – 40 GHz range.

SOP 1 Radiated Emissions

Tracking # 31360999.002 Page 12 of 15

EUT Name	Wireless Video Access Point	Date	April 10, 2013
EUT Model	405	Temp / Hum in	23°C / 33%rh
EUT Serial	09130M000104	Temp / Hum out	N/A
EUT Config.	Y-Axis, 802.11 HT40 at 13.5Mbps	Line AC	120Vac 60Hz
Standard	CFR47 Part 15 Subpart C	RBW / VBW	1 MHz / 3MHz
Dist/Ant Used	3m - EMCO3115 / 1m - RA42-K-F-4B-C	Performed by	Jeremy Luong

Above 1GHz Plots for Transmit Mode at 5755 MHz

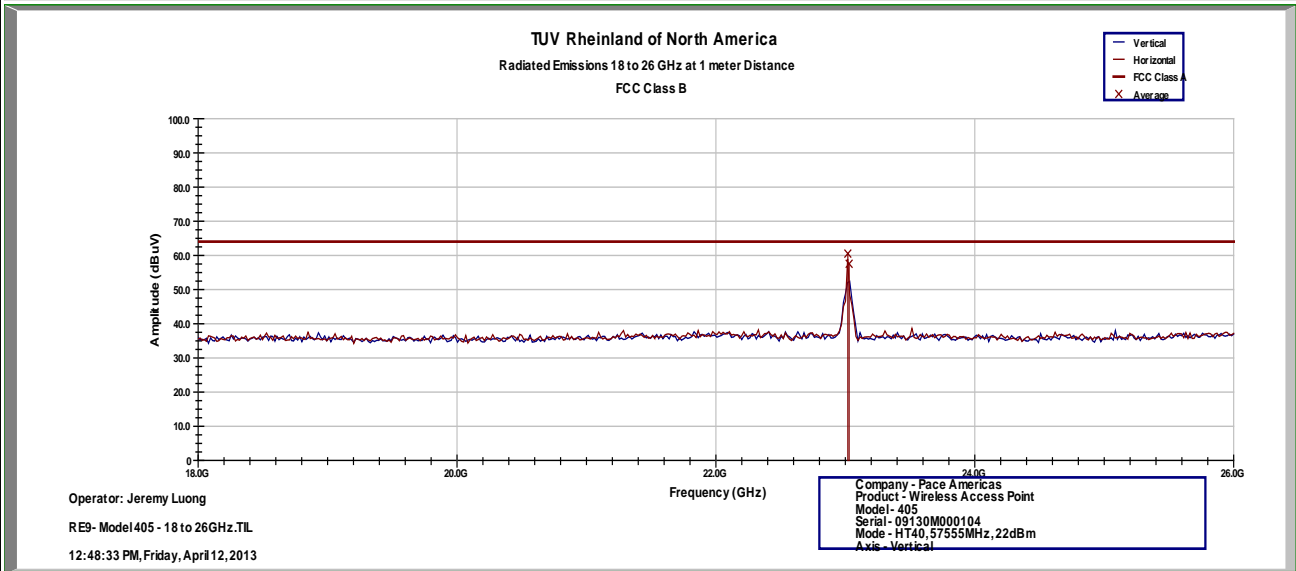
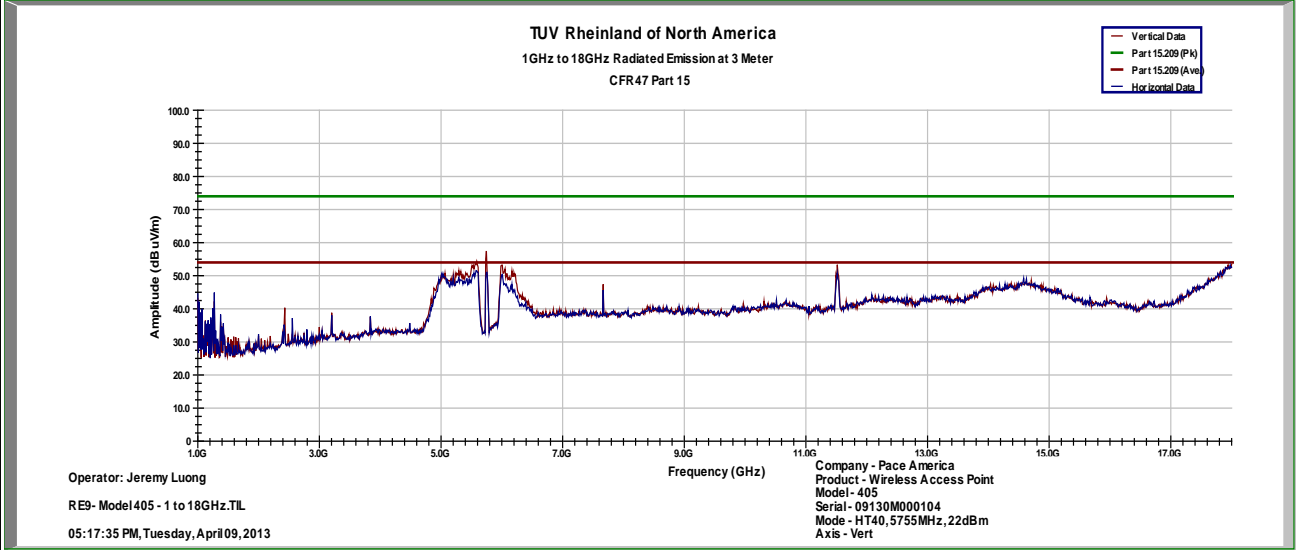

Notes: Limit was extrapolated to 1m distance for 18GHz – 40 GHz range.

SOP 1 Radiated Emissions

Tracking # 31360999.002 Page 13 of 15

EUT Name	Wireless Video Access Point	Date	April 10, 2013
EUT Model	405	Temp / Hum in	23°C / 33%rh
EUT Serial	09130M000104	Temp / Hum out	N/A
EUT Config.	Y-Axis, 802.11 HT40 at 13.5Mbps	Line AC	120Vac 60Hz
Standard	CFR47 Part 15 Subpart C	RBW / VBW	1 MHz / 3MHz
Dist/Ant Used	1m - RA42-K-F-4B-C	Performed by	Jeremy Luong

Above 1GHz Plots for Transmit Mode at 5755 MHz

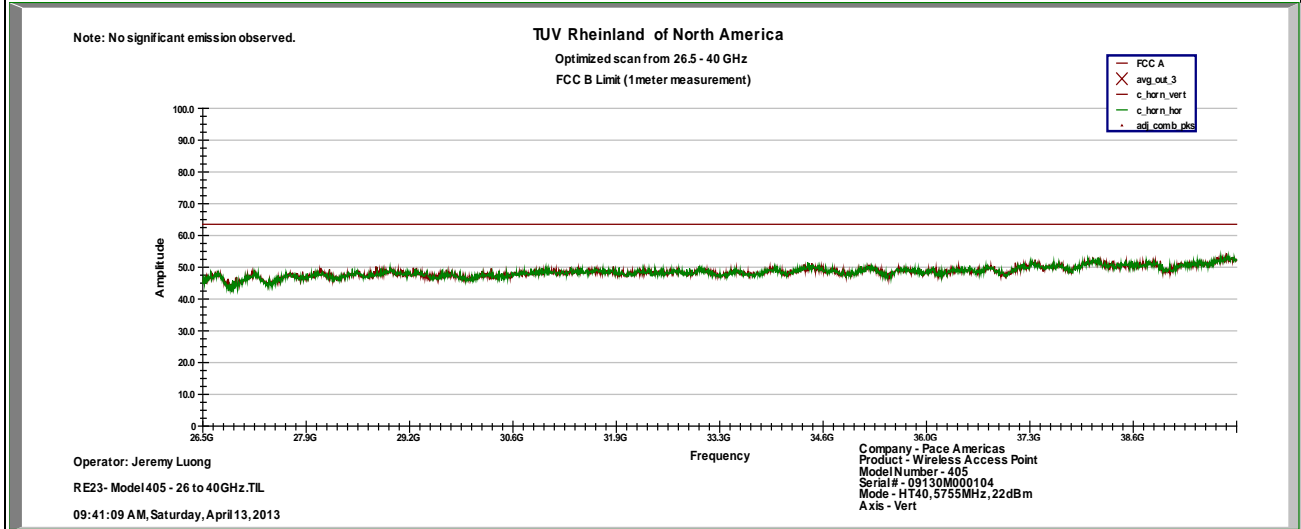

Notes: Limit was extrapolated to 1m distance for 18GHz – 40 GHz range.

SOP 1 Radiated Emissions

Tracking # 31360999.002 Page 14 of 15

EUT Name	Wireless Video Access Point	Date	April 10, 2013
EUT Model	405	Temp / Hum in	23°C / 33%rh
EUT Serial	09130M000104	Temp / Hum out	N/A
EUT Config.	Y-Axis, 802.11 HT40 at 13.5Mbps	Line AC	120Vac 60Hz
Standard	CFR47 Part 15 Subpart C	RBW / VBW	1 MHz / 3MHz
Dist/Ant Used	3m - EMCO3115 / 1m - RA42-K-F-4B-C	Performed by	Jeremy Luong

Above 1GHz Plots for Transmit Mode at 5795 MHz

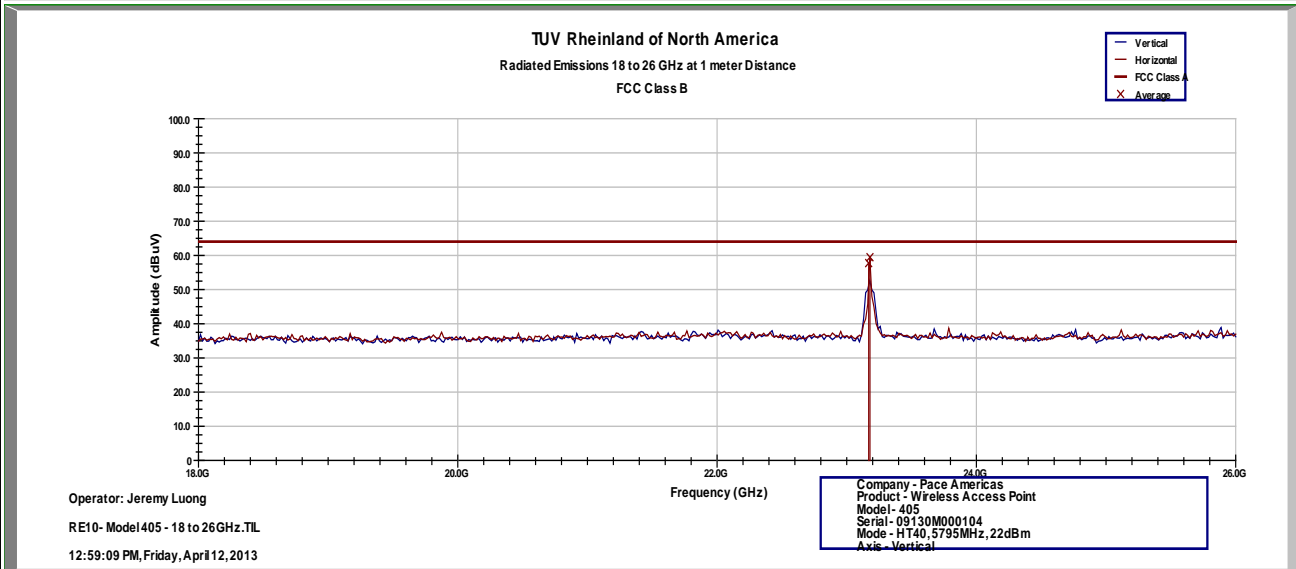
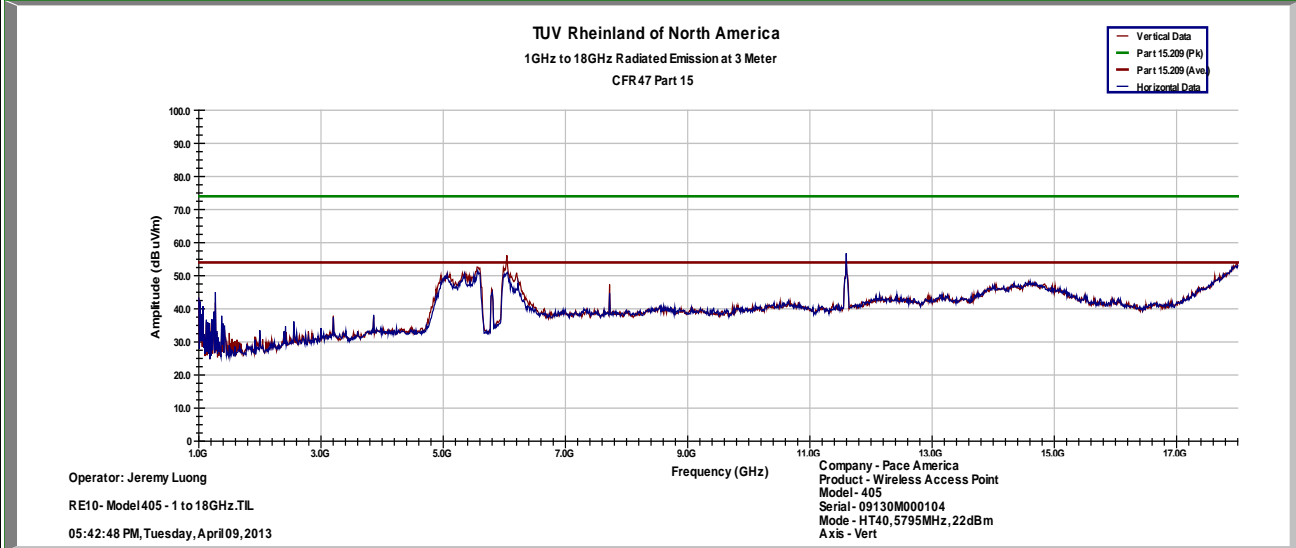

Notes: Limit was extrapolated to 1m distance for 18GHz – 40 GHz range.
 1GHz – 25 GHz Setting: RBW = 1 MHz/ VBW = 3MHz

SOP 1 Radiated Emissions

Tracking # 31360999.002 Page 15 of 15

EUT Name	Wireless Video Access Point	Date	April 10, 2013
EUT Model	405	Temp / Hum in	23°C / 33%rh
EUT Serial	09130M000104	Temp / Hum out	N/A
EUT Config.	Y-Axis, 802.11 HT40 at 13.5Mbps	Line AC	120Vac 60Hz
Standard	CFR47 Part 15 Subpart C	RBW / VBW	1 MHz / 3MHz
Dist/Ant Used	3m - EMCO3115 / 1m - RA42-K-F-4B-C	Performed by	Jeremy Luong

Above 1GHz Plots for Transmit Mode at 5795 MHz

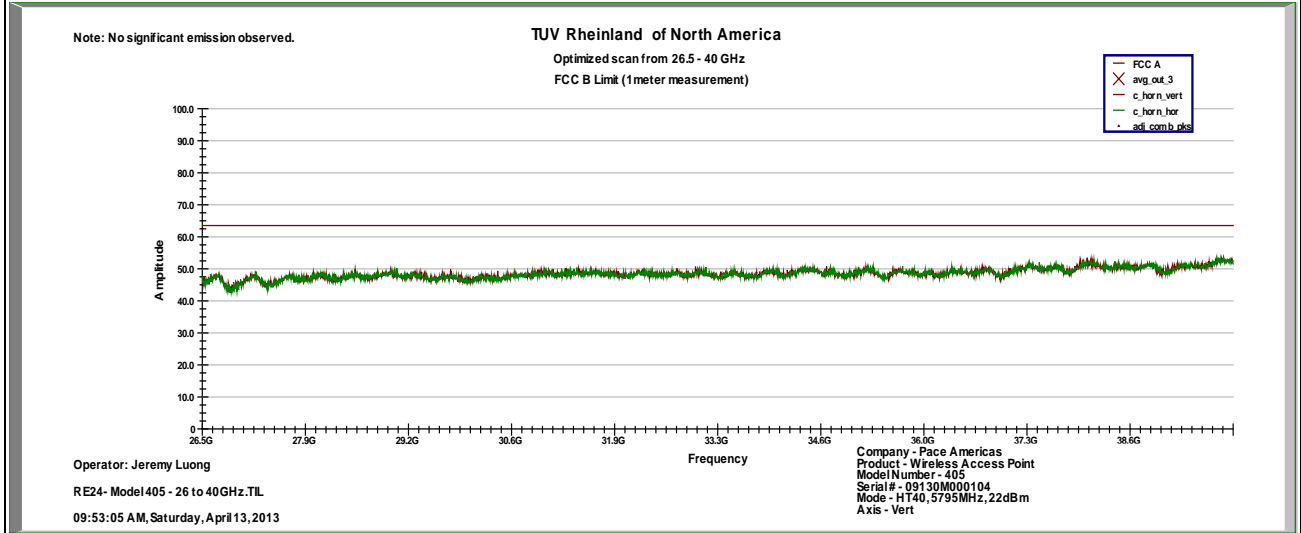

Notes: Limit was extrapolated to 1m distance for 18GHz – 40 GHz range.

4.5.4 Sample Calculation

The field strength is calculated by subtracting the Amplifier Gain and adding the Cable Loss and Antenna Correction Factor to the measured reading. The basic equation is as follows:

$$\text{Field Strength (dB}\mu\text{V/m)} = \text{FIM} - \text{AMP} + \text{CBL} + \text{ACF}$$

- Where: FIM = Field Intensity Meter (dBμV)
- AMP = Amplifier Gain (dB)
- CBL = Cable Loss (dB)
- ACF = Antenna Correction Factor (dB/m)

$$\mu\text{V/m} = 10^{\frac{\text{dB}\mu\text{V} / \text{m}}{20}}$$

4.6 AC Conducted Emissions

Testing was performed in accordance with ANSI C63.4: 2010. These test methods are listed under the laboratory's A2LA Scope of Accreditation.

This test measures the levels emanating from the EUT's AC input port, thus evaluating the potential for the EUT to cause radio frequency interference to other electronic devices.

The AC conducted emissions of equipment under test shall not exceed the values in CFR47 Part 15.207: 2012 and RSS 210: 2010.

4.6.1 Test Methodology

A test program that controls instrumentation and data logging was used to automate the AC Power Line Conducted emission test procedure. The frequency range of interest was divided into sub-ranges such as to yield a frequency resolution of 9 kHz. Each phase and neutral of the AC power line were measured with respect to ground. Measurements were performed using a set of 50µH / 50Ω LISNs.

Testing is either performed in Lab 2. The setup photographs clearly identify which site was used. The vertical ground plane used in the semi-anechoic chamber is a 2m x 2m solid aluminum frame and panel, and it is bonded to the horizontal ground plane.

In the case of tabletop equipment, the EUT is placed on a 1.0m x 1.5m non-conductive table 80cm above the ground plane and 40cm from a vertical ground reference plane. The rear of the EUT was positioned flush with the backside of the table and directly over the LISNs. The power and I/O cables were routed over the edge of the table and bundled approximately 40cm from the ground plane. Support equipment was powered from a separate LISN.

4.6.1.1 Deviations

There were no deviations from this test methodology.

4.6.2 Test Results

As originally tested, the EUT was found to be compliant to the requirements of the test standard(s).

Table 8: AC Conducted Emissions – Test Results

Test Conditions: Conducted Measurement at Normal Conditions only		
Antenna Type: Attached		Power Level: See Test Plan
AC Power: 120 Vac/60 Hz		Configuration: Tabletop
Ambient Temperature: 22° C		Relative Humidity: 37% RH
Configuration	Frequency Range	Test Result
Line 1 (Hot)	0.15 to 30 MHz	Pass
Line 2 (Neutral)	0.15 to 30 MHz	Pass

SOP 2 Conducted Emissions						Tracking # 31360999.002 Page 1 of 4				
EUT Name	Wireless Video Access Point					Date	April 20, 2013			
EUT Model	405					Temp / Hum in	23° C / 34% rh			
EUT Serial	09130M000104					Temp / Hum out	N/A			
EUT Config.	Attached Antenna					Line AC / Freq	120Vac/60Hz			
Standard	CFR47 Part 15.207					RBW / VBW	9kHz / 30 kHz			
Lab/LISN	Lab #2 /Com-Power, Line 1					Performed by	Jeremy Luong			
Frequency	Raw	Limiter	Ins. Loss	Level	Detector	Line	Limit	Margin	Result	
MHz	dBuV	dB	dB	dBuV		Line	dBuV	dB		
0.171	31.82	10.12	-0.66	41.28	QP	Live	64.90	-23.62	Pass	
0.171	-7.72	10.12	-0.66	1.74	Ave	Live	54.90	-53.16	Pass	
0.190	40.64	10.12	-0.60	50.17	QP	Live	64.02	-13.85	Pass	
0.190	18.39	10.12	-0.60	27.92	Ave	Live	54.02	-26.10	Pass	
0.190	40.24	10.12	-0.60	49.77	QP	Live	64.02	-14.25	Pass	
0.190	18.76	10.12	-0.60	28.29	Ave	Live	54.02	-25.73	Pass	
5.395	27.78	10.28	-0.13	37.93	QP	Live	60.00	-22.07	Pass	
5.395	19.78	10.28	-0.13	29.93	Ave	Live	50.00	-20.07	Pass	
6.074	25.25	10.30	-0.13	35.42	QP	Live	60.00	-24.58	Pass	
6.074	17.62	10.30	-0.13	27.79	Ave	Live	50.00	-22.21	Pass	
8.981	24.79	10.40	-0.10	35.09	QP	Live	60.00	-24.91	Pass	
8.981	17.91	10.40	-0.10	28.21	Ave	Live	50.00	-21.79	Pass	
9.693	25.89	10.42	-0.10	36.21	QP	Live	60.00	-23.79	Pass	
9.693	19.22	10.42	-0.10	29.54	Ave	Live	50.00	-20.46	Pass	
11.205	25.05	10.45	-0.09	35.41	QP	Live	60.00	-24.59	Pass	
11.205	18.47	10.45	-0.09	28.83	Ave	Live	50.00	-21.17	Pass	
12.089	24.66	10.46	-0.08	35.04	QP	Live	60.00	-24.96	Pass	
12.089	18.10	10.46	-0.08	28.48	Ave	Live	50.00	-21.52	Pass	
Spec Margin = QP./Ave. - Limit, ± Uncertainty										
Combined Standard Uncertainty $u_c(y) = \pm 1.2$ dB Expanded Uncertainty $U = ku_c(y)$ $k = 2$ for 95% confidence										
Notes: EUT was setup as table top equipment and transmitted at 5785 MHz in HT20 at 6.5Mbps										

SOP 2 Conducted Emissions

Tracking # 31360999.002 Page 2 of 4

EUT Name	Wireless Video Access Point	Date	April 20, 2013
EUT Model	405	Temp / Hum in	23° C / 34% rh
EUT Serial	09130M000104	Temp / Hum out	N/A
EUT Config.	Attached Antenna	Line AC	120Vac/60Hz
Standard	CFR47 Part 15.207	RBW / VBW	9kHz / 30 kHz
Lab/LISN	Lab #2 /Com-Power, Line 1	Performed by	Jeremy Luong

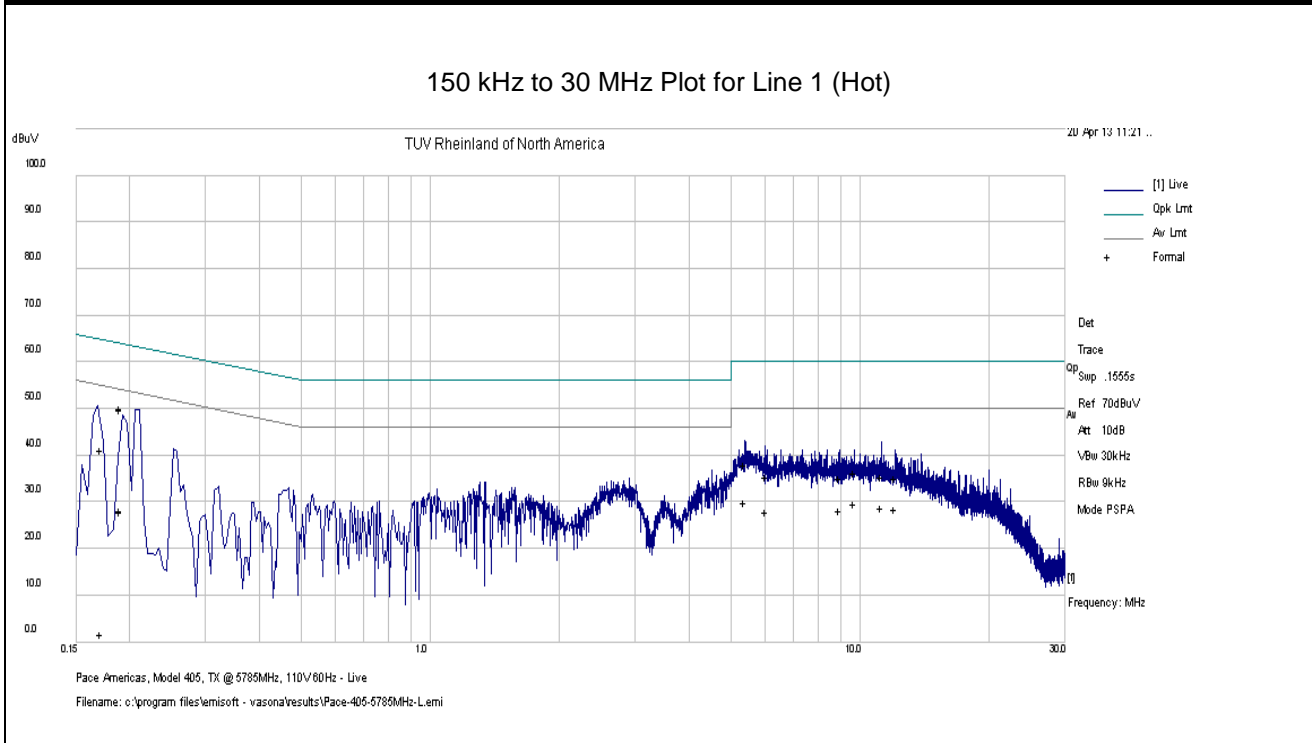

Notes: Meet FCC Class B limit.

SOP 2 Conducted Emissions						Tracking # 31360999.002 Page 3 of 4			
EUT Name		Wireless Video Access Point				Date		April 20, 2013	
EUT Model		405				Temp / Hum in		23° C / 34% rh	
EUT Serial		09130M000104				Temp / Hum out		N/A	
EUT Config.		Attached Antenna				Line AC / Freq		120Vac/60Hz	
Standard		CFR47 Part 15.207				RBW / VBW		9kHz / 30 kHz	
Lab/LISN		Lab #2 /Com-Power, Line 2				Performed by		Jeremy Luong	
Frequency	Raw	Limiter	Ins. Loss	Level	Detector	Line	Limit	Margin	Result
MHz	dBuV	dB	dB	dBuV		Line	dBuV	dB	
0.191	38.80	10.12	-0.60	48.33	QP	Neutral	64.01	-15.68	Pass
0.191	19.28	10.12	-0.60	28.81	Ave	Neutral	54.01	-25.20	Pass
0.193	38.56	10.13	-0.59	48.09	QP	Neutral	63.91	-15.82	Pass
0.193	21.16	10.13	-0.59	30.69	Ave	Neutral	53.91	-23.22	Pass
0.454	26.21	10.16	-0.33	36.04	QP	Neutral	56.81	-20.77	Pass
0.454	13.78	10.16	-0.33	23.61	Ave	Neutral	46.81	-23.20	Pass
5.461	27.79	10.28	-0.13	37.94	QP	Neutral	60.00	-22.06	Pass
5.461	19.43	10.28	-0.13	29.58	Ave	Neutral	50.00	-20.42	Pass
6.734	27.35	10.32	-0.12	37.55	QP	Neutral	60.00	-22.45	Pass
6.734	19.13	10.32	-0.12	29.33	Ave	Neutral	50.00	-20.67	Pass
7.621	26.09	10.36	-0.12	36.33	QP	Neutral	60.00	-23.67	Pass
7.621	18.10	10.36	-0.12	28.34	Ave	Neutral	50.00	-21.66	Pass
10.485	25.55	10.43	-0.10	35.89	QP	Neutral	60.00	-24.11	Pass
10.485	18.69	10.43	-0.10	29.03	Ave	Neutral	50.00	-20.97	Pass
11.140	25.22	10.45	-0.09	35.58	QP	Neutral	60.00	-24.42	Pass
11.140	18.82	10.45	-0.09	29.18	Ave	Neutral	50.00	-20.82	Pass
12.331	24.13	10.46	-0.08	34.52	QP	Neutral	60.00	-25.48	Pass
12.331	17.72	10.46	-0.08	28.11	Ave	Neutral	50.00	-21.89	Pass
Spec Margin = QP./Ave. - Limit, ± Uncertainty									
Combined Standard Uncertainty $u_c(y) = \pm 1.2$ dB Expanded Uncertainty $U = k u_c(y)$ $k = 2$ for 95% confidence									
Notes: EUT was setup as table top equipment and transmitted at 5785 MHz in HT20 at 6.5Mbps									

SOP 2 Conducted Emissions

Tracking # 31360999.002 Page 4 of 4

EUT Name	Wireless Video Access Point	Date	April 20, 2013
EUT Model	405	Temp / Hum in	23° C / 34% rh
EUT Serial	09130M000104	Temp / Hum out	N/A
EUT Config.	Attached Antenna	Line AC	120Vac/60Hz
Standard	CFR47 Part 15.207	RBW / VBW	9kHz / 30 kHz
Lab/LISN	Lab #2 /Com-Power, Line 2	Performed by	Jeremy Luong

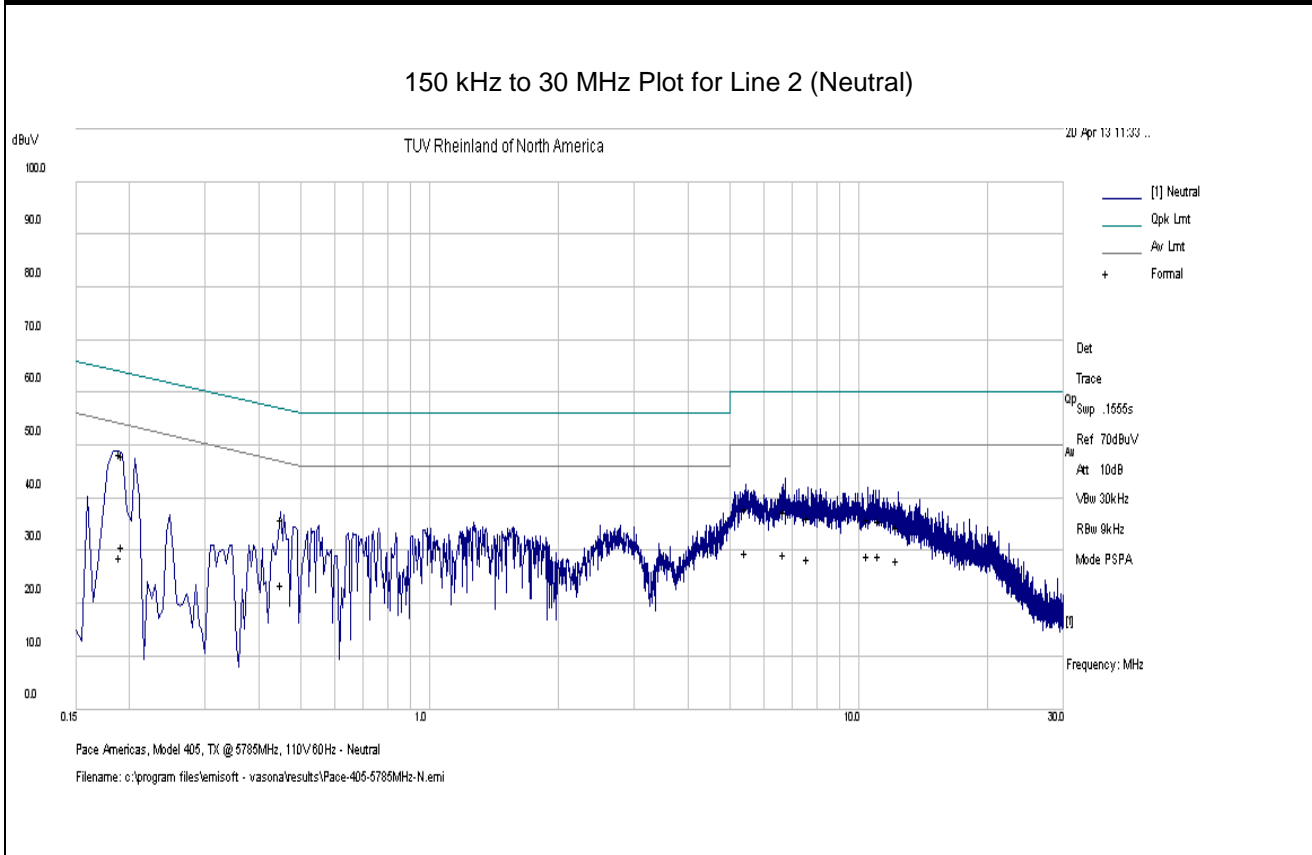

Note: Meet FCC Class B Limit.

4.7 Maximum Permissible Exposure

4.7.1 Test Methodology

In this document, we try to prove the safety of radiation harmfulness to the human body for our product. The limit for Maximum Permissible Exposure (MPE) specified in FCC 1.1310 is followed. The Gain of the antenna used in this calculation is declared by the manufacturer, and the maximum total power input to the antenna is measured. Through the Friis transmission formula and the maximum gain of the antenna, we can calculate the distance, away from the product, where the limit of MPE is reached.

Although the Friis transmission formula is a far field assumption, the calculated result of that is an over-prediction for near field power density. We will take that as the worst case to specify the safety range.

4.7.2 RF Exposure Limit

According to FCC 1.1310 table 1: The criteria listed in the following table shall be used to evaluate the environmental impact of human exposure to radio-frequency (RF) radiation as specified in 1.1307(b)

LIMITS FOR MAXIMUM PERMISSIBLE EXPOSURE (MPE)

Frequency Range (MHz)	Electric Field Strength (V/m)	Magnetic Field Strength (A/m)	Power Density (mW/cm ²)	Average Time (minutes)
(A)Limits For Occupational / Control Exposures				
0.3–3.0	614	1.63	*(100)	6
3.0–30	1842/f	4.89/f	*(900/f ²)	6
30–300	1.0	6
300 - 1500	f/300	6
1500 - 100,000	5	6
(B)Limits For General Population / Uncontrolled Exposure				
0.3–1.34	614	1.63	*(100)	30
1.34-30	824/f	2.19/f	*(180/ f ²)	30
30–300	27.5	0.037	0.2	30
300 - 1500	f/1500	30
1500 - 100,000	1.0	30

F = Frequency in MHz

* = Plane-wave equivalent power density

4.7.3 EUT Operating Condition

The software provided by Manufacturer enabled the EUT to transmit data at lowest, middle and highest channel individually.

4.7.4 Classification

The antenna of the product, under normal use condition, is at least 20cm away from the body of the user. Warning statement to the user for keeping at least 20cm or more separation distance with the antenna should be included in user's manual. So, this device is classified as a **Mobile Device**.

4.7.5 Test Results

4.7.5.1 Antenna Gain

The transmitting antenna was integrated. The directional antenna gain was +2.00 dBi or 1.58 (numeric).

4.7.5.2 Output Power into Antenna & RF Exposure value at distance 20cm:

Calculations for this report are based on highest power measurement.

Limit for MPE (from FCC part 1.1310 table1) is 1.0 mW/cm²

The highest measured total power is +27.41 dBm or 550.8077mW

Using the Friss transmission formula, the EIRP is Pout*G, and R is 20cm.

$Pd = (550.8077 * 1.58) / (1600\pi) = 0.1732 \text{ mW/cm}^2$, which is 0.8268 mW/cm² below to the limit.

As originally tested, the EUT was found to be compliant to the requirements of the test standard(s).

4.7.6 Sample Calculation

The Friss transmission formula: $Pd = (Pout * G) / (4 * \pi * R^2)$

Where;

Pd = power density in mW/cm²

Pout = output power to antenna in mW

G = gain of antenna in linear scale

$\pi \approx 3.1416$

R = distance between observation point and center of the radiator in cm

Ref. : David K. Cheng, *Field and Wave Electromagnetics*, Second Edition, Page 640, Eq. (11-133).

5 Test Equipment List

5.1 Equipment List

Equipment	Manufacturer	Model #	Serial/Inst #	Last Cal dd/mm/yy	Next Cal dd/mm/yy
Bilog Antenna	Sunol Sciences	JB3	A102606	05/15/2012	05/15/2014
Horn Antenna	Sunol Sciences	DRH-118	A040806	11/05/2012	11/05/2014
Antenna (18-26GHz)	CMT	RA42-K-F-4B-C	020131-004	03/05/2013	03/05/2014
Antenna (26-40 GHz)	CMT	RA28-K-F-4B-C	011469R-003	11/20/2012	11/20/2014
EMI Receiver	Hewlett Packard	8546A	3807A00445	01/18/2013	01/18/2014
Preselector	Hewlett Packard	85460A	3704A00407	01/18/2013	01/18/2014
Amplifier	Hewlett Packard	8447D	2944A07996	01/16/2013	01/16/2014
Spectrum Analyzer	Rohde & Schwarz	ESIB	832427/002	01/16/2013	01/16/2014
Amplifier	Rohde & Schwarz	TS-PR18	3545.7008.03	01/16/2013	01/16/2014
Amplifier	Rohde & Schwarz	TS-PR26	100011	03/05/2013	03/05/2014
Amplifier	Rohde & Schwarz	TS-PR40	100012	11/20/2012	11/20/2014
Signal Generator	Anritsu	MG3694A	42803	01/19/2013	01/19/2014
Notch Filter	Micro-Tronics	BRM50702	37	01/16/2013	01/16/2014
Notch Filter	Micro-Tronics	BRC50703	11	01/16/2013	01/16/2014
Notch Filter	Micro-Tronics	BRC50704	8	01/16/2013	01/16/2014
Notch Filter	Micro-Tronics	BRC50705	9	01/16/2013	01/16/2014
High Pass Filter (3.5 GHz)	Hewlett Packard	84300-80038	820004	01/16/2013	01/16/2014
High Pass Filter (8.5 GHz)	Micro-Tronics	HPM50107	4	01/16/2013	01/16/2014
Power Supplier	Kikosui	PCR8000W	CM000912	01/17/2013	01/17/2014
Digital Multimeter	Fluke	177	92780314	01/17/2013	01/17/2014
Power Meter	Agilent	E4418B	MY45103902	01/19/2013	01/19/2014
Power Sensor	Hewlett Packard	8482A	55-5131	01/19/2013	01/19/2014
EMI Receiver	Hewlett Packard	8546A	3942A00514	07/02/2012	07/02/2013
Preselector	Hewlett Packard	85460A	3704A00485	07/02/2012	07/02/2013
LISN	Com-Power	LI-215	12100	01/16/2013	01/16/2014
Transient Limiter	Com-Power	LIT-930	531582	01/16/2013	01/16/2014
Thermometer	Fluke	52II	88650033	07/26/2012	07/26/2013
Thermo Chamber	Espec	BTZ-133	0613436	03/11/2013	03/11/2014
Spectrum Analyzer	Rohde & Schwarz	FSL6	100169	02/07/2013	02/07/2014
Spectrum Analyzer	Agilent	N9038A	MY51210195	01/19/2013	01/19/2014
Vector Signal Generator	Rohde & Schwarz	SMU 200A	1141.2005.02	11/24/2011	11/24/2013
Amplifier	Hewlett Packard	8449B	30008A01014	01/17/2013	01/17/2014

* Calibration of equipment past due for re-calibration will be performed expeditiously. If any equipment is found to be out of tolerance at that time, affected customers will be notified accordingly.

6 EMC Test Plan

6.1 Introduction

This section provides a description of the Equipment Under Test (EUT), configurations, operating conditions, and performance acceptance criteria. It is an overview of information provided by the manufacturer so that the test laboratory may perform the requested testing.

6.2 Customer

Table 9: Customer Information

Company Name	Pace Americas
Address	310 Providence Mine Road, Ste. 200
City, State, Zip	Nevada City, CA 95959
Country	USA
Phone	(530) 274 5440
Fax	(530) 273 6340

Table 10: Technical Contact Information

Name	Mark Rieger
E-mail	Mark.Rieger@pace.com
Phone	(530) 274 5440
Fax	(530) 273 6340

6.3 Equipment Under Test (EUT)

Table 11: EUT Specifications

EUT Specifications	
Dimensions	6.0" x 5.6" x 1.3"
AC Adapter (Pace M/N:T018WA1225, S/N:810611302000003156)	Input Voltage: 120Vac 50-60Hz Input Current: 680mA Output Voltage: 12VDC Output Current: 1.5A
Environment	Indoor and Outdoor
Operating Temperature Range:	0 to 40 degrees C
Multiple Feeds:	<input type="checkbox"/> Yes and how many <input checked="" type="checkbox"/> No
Hardware Version	Rev. A1C
Part Number	297T1001700
RF Software Version	Busy Box V1.10.3
802.11-radio modules	
Operating Mode	802.11n HT20 and HT40
Transmitter Frequency Band	5.15 GHz to 5.25 GHz (Indoor Use) 5.725 GHz to 5.85 GHz
Max. Rated Power Output	See Channel Planning Table.
Power Setting @ Operating Channel	See Channel Planning Table.
Antenna Type	3 integrated PCB Antenna and 1 stamped metal loop antenna
Antenna Gain	+2 dBi per antenna. (Same for both antenna type)
Modulation Type	<input type="checkbox"/> AM <input type="checkbox"/> FM <input checked="" type="checkbox"/> DSSS <input checked="" type="checkbox"/> OFDM <input type="checkbox"/> Other describe:
Data Rate	802.11n HT20: 4 Spatial Streams: 26, 52, 78, 104, 156, 208, 234, 260 Mbps 802.11n HT40: 4 Spatial Streams: 54, 108, 162, 216, 324, 432, 486, 540 Mbps
TX/RX Chain (s)	MIMO (4x4)
Directional Gain Type	<input checked="" type="checkbox"/> Correlated <input checked="" type="checkbox"/> Beam-Forming <input type="checkbox"/> Other describe:
Type of Equipment	<input checked="" type="checkbox"/> Table Top <input type="checkbox"/> Wall-mount <input type="checkbox"/> Floor standing cabinet <input type="checkbox"/> Other

EUT Specifications

Note: 1. All four chains will be on / transmitted at all time.
2. This report only documents the radio characteristics for 5150 – 5250 MHz band

Table 12: EUT Channel Power Specifications

No.	Frequency (MHz)	Target Power Value				
		802.11b	802.11g	802.11a	802.11n HT20	802.11n HT40
36	5180				10.0	11
40	5200				9.0	
44	5220				9.0	11
48	5240				9.0	
52	5260					
56	5280					
60	5300					
64	5320					
100	5500					
104	5520					
108	5540					
112	5560					
116	5580					
120	5600					
124	5620					
128	5640					
132	5660					
136	5680					
140	5700					
149	5745				22.0	22.0
153	5765				22.0	
157	5785				22.0	22.0
159	5795				22.0	
161	5805				22.0	
165	5825				22.0	

Note: 1. The center operating frequency is shifted upward by 10 MHz for HT40.
 2. The adjusted power target values are updated at the evaluated frequencies.

Table 13: Interface Specifications

Interface Type	Cabled with what type of cable?	Is the cable shielded?	Maximum potential length of the cable?	Metallic (M), Coax (C), Fiber (F), or Not Applicable?
RJ45	CAT-5 Ethernet	<input type="checkbox"/> No	<input checked="" type="checkbox"/> Metric: 10 m	<input checked="" type="checkbox"/> M

Table 14: Supported Equipment

Equipment	Manufacturer	Model	Serial	Used for
Laptop	Dell	PP23LB	9271001233	Setup EUT operating channel
Note: None.				

Table 15: Description of Sample used for Testing

Device	Serial	RF Connection	CFR47 Part 15.247
405	09130M000104	Integrated Antenna	Radiated Emission. AC Conducted Emission
		Direct via Murada Connection	Output Power, Peak Power Spectral Density, Occupied Bandwidth Conducted Spurious Emission

Table 16: Description of Test Configuration used for Radiated Measurement.

Device	Antenna	Mode	Setup Photo (X-Axis)	Setup Photo (Y-Axis)	Setup Photo (Z-Axis)
Model 405	Integrated	Transmit	EUT laid flat.	EUT stood upright	Na.
Note: Pre-scans were performed in 2 supporting axis, and Y-axis was worst.					

Table 17: Final Test Mode for 5725 - 5850 Bands

Test	802.11a	802.11n HT20	802.11n HT40
Occupied Bandwidth CFR47 15.247 (a2), RSS GEN Sect.4.4.1		Band : 5745, 5785, 5825 MHz 4 Streams – 6.5Mbps/ stream	Band : 5755, 5795 MHz 4 Streams – 13.5Mbps/ stream
Output Power CFR47 15.247 (b3), RSS 210 Sect. A.8.4		Band : 5745, 5785, 5825 MHz 4 Streams – 6.5Mbps/ stream	Band : 5755, 5795 MHz 4 Streams – 13.5Mbps/ stream
Peak Power Spectral Density CFR47 15.247 (e), RSS 210 Sect. A.8.2		Band : 5745, 5785, 5825 MHz 4 Streams – 6.5Mbps/ stream	Band : 5755, 5795 MHz 4 Streams – 13.5Mbps/ stream

Test	802.11a	802.11n HT20	802.11n HT40
Out-of-Band (-30 dB). CFR47 15.247 (d), RSS 210 Sect. A.8.5		Band : 5745, 5785, 5825 MHz 4 Streams – 6.5Mbps/ stream	Band : 5755, 5795 MHz 4 Streams – 13.5Mbps/ stream
Band-Edge (Radiated) FCC Part 15.205, 15.209		Band : 5745, 5785, 5825 MHz 4 Streams – 6.5Mbps/ stream	Band : 5755, 5795 MHz 4 Streams – 13.5Mbps/ stream
Transmitted Spurious Emission (30 MHz – 1GHz) FCC Part 15.205, 15.209		Worst Case: 5785 MHz 4 Streams – 6.5Mbps/ stream (Y-Axis)	
Transmitted Spurious Emission (Above 1GHz) FCC Part 15.205, 15.209		Band : 5745, 5785, 5825 MHz 4 Streams – 6.5Mbps/ stream	Band : 5755, 5795 MHz 4 Streams – 13.5Mbps/ stream
AC Conducted Emission FCC Part 15.207		5785 MHz at 4 Data Stream: 6.5Mbps	
<p>Note: 1. Band 5725 MHz – 5850 MHz does not support 802.11a. 2. All radiated emission performed on Y-Axis; worst axis. 3. All four chains will be on at all time during the EUT's deployment. 4. All tests were pre-scanned for worst case before final testing.</p>			

6.4 Test Specifications

Testing requirements

Table 18: Test Specifications

Emissions and Immunity	
Standard	Requirement
CFR 47 Part 15.407: 2012	All
RSS 210 Issue 8, 2010	All

END OF REPORT