

EMC Test Report

Application for FCC Grant of Equipment Authorization and

FCC Part 15 Subpart C

Model: 260-E255030

FCC ID: PGR2G4360M

APPLICANT: Pace Americas Inc.
310 Providence Mine Road
Nevada City, CA 95959

TEST SITE(S): National Technical Systems - Silicon Valley
41039 Boyce Road.
Fremont, CA. 94538-2435

IC SITE REGISTRATION #: 2845B-3; 2845B-4, 2845B-5, 2845B-7

REPORT DATE: February 26, 2016

REISSUED DATE: March 4, 2016

FINAL TEST DATES: January 5, 6 and 11, February 2, 4, 8, 9 and 10,
2016

TOTAL NUMBER OF PAGES: 136

PROGRAM MGR /
TECHNICAL REVIEWER:

QUALITY ASSURANCE DELEGATE /
FINAL REPORT PREPARER:



David W. Bare
Chief Engineer



David Guidotti
Senior Technical Writer



National Technical Systems - Silicon Valley is accredited by the A2LA, certificate number 0214.26, to perform the test(s) listed in this report, except where noted otherwise. This report and the information contained herein represent the results of testing test articles identified and selected by the client performed to specifications and/or procedures selected by the client. National Technical Systems (NTS) makes no representations, expressed or implied, that such testing is adequate (or inadequate) to demonstrate efficiency, performance, reliability, or any other characteristic of the articles being tested, or similar products. This report should not be relied upon as an endorsement or certification by NTS of the equipment tested, nor does it represent any statement whatsoever as to its merchantability or fitness of the test article, or similar products, for a particular purpose. This report shall not be reproduced except in full



REVISION HISTORY

Rev#	Date	Comments	Modified By
-	February 26, 2016	First release	
1	March 4, 2016	Revised test log to correct typos, update statement about maximum RBW/VBW. Added statement about beam forming and non-beam forming. Removed preliminary test results	David W. Bare and David Guidotti

TABLE OF CONTENTS

REVISION HISTORY	2
TABLE OF CONTENTS	3
SCOPE	5
OBJECTIVE	5
STATEMENT OF COMPLIANCE	6
DEVIATIONS FROM THE STANDARDS	6
TEST RESULTS SUMMARY	7
DIGITAL TRANSMISSION SYSTEMS (2400 – 2483.5MHZ)	7
GENERAL REQUIREMENTS APPLICABLE TO ALL BANDS	7
MEASUREMENT UNCERTAINTIES	8
EQUIPMENT UNDER TEST (EUT) DETAILS	9
GENERAL.....	9
OTHER EUT DETAILS.....	9
ANTENNA SYSTEM	9
ENCLOSURE.....	9
MODIFICATIONS.....	9
SUPPORT EQUIPMENT.....	9
EUT INTERFACE PORTS	10
EUT OPERATION	10
TEST SITE	11
GENERAL INFORMATION	11
CONDUCTED EMISSIONS CONSIDERATIONS	11
RADIATED EMISSIONS CONSIDERATIONS	11
MEASUREMENT INSTRUMENTATION	12
RECEIVER SYSTEM	12
INSTRUMENT CONTROL COMPUTER	12
LINE IMPEDANCE STABILIZATION NETWORK (LISN).....	12
FILTERS/ATTENUATORS	13
ANTENNAS.....	13
ANTENNA MAST AND EQUIPMENT TURNTABLE.....	13
INSTRUMENT CALIBRATION.....	13
TEST PROCEDURES	14
EUT AND CABLE PLACEMENT	14
CONDUCTED EMISSIONS.....	14
RADIATED EMISSIONS.....	14
CONDUCTED EMISSIONS FROM ANTENNA PORT	18
BANDWIDTH MEASUREMENTS	18
SPECIFICATION LIMITS AND SAMPLE CALCULATIONS	19
CONDUCTED EMISSIONS SPECIFICATION LIMITS: FCC 15.207; FCC 15.107(A), RSS GEN	19
GENERAL TRANSMITTER RADIATED EMISSIONS SPECIFICATION LIMITS	20
RECEIVER RADIATED SPURIOUS EMISSIONS SPECIFICATION LIMITS	20
OUTPUT POWER LIMITS – DIGITAL TRANSMISSION SYSTEMS	20
TRANSMIT MODE SPURIOUS RADIATED EMISSIONS LIMITS – FHSS AND DTS SYSTEMS.....	21
SAMPLE CALCULATIONS - CONDUCTED EMISSIONS	21
SAMPLE CALCULATIONS - RADIATED EMISSIONS.....	21
GENERAL TRANSMITTER RADIATED EMISSIONS SPECIFICATION LIMITS	22
RECEIVER RADIATED SPURIOUS EMISSIONS SPECIFICATION LIMITS	22
OUTPUT POWER LIMITS – DIGITAL TRANSMISSION SYSTEMS	23
OUTPUT POWER LIMITS – FHSS SYSTEMS	23
TRANSMIT MODE SPURIOUS RADIATED EMISSIONS LIMITS – FHSS AND DTS SYSTEMS.....	23
FCC 15.407 (A) OUTPUT POWER LIMITS.....	24
OUTPUT POWER LIMITS –LELAN DEVICES.....	24
SPURIOUS EMISSIONS LIMITS –UNII AND LELAN DEVICES	24



SAMPLE CALCULATIONS - CONDUCTED EMISSIONS25
 SAMPLE CALCULATIONS - RADIATED EMISSIONS25
 SAMPLE CALCULATIONS - FIELD STRENGTH TO EIRP CONVERSION.....26
APPENDIX A TEST EQUIPMENT CALIBRATION DATA27
APPENDIX B TEST DATA29
END OF REPORT136

SCOPE

An electromagnetic emissions test has been performed on the Pace Americas Inc. model 260-E255030, pursuant to the following rules:

Industry Canada RSS-Gen Issue 4

RSS 247 Issue 1 “ Digital Transmission Systems (DTSs), Frequency Hopping Systems (FHSs) and Licence-Exempt Local Area Network (LE-LAN) Devices”

FCC Part 15 Subpart C

Conducted and radiated emissions data has been collected, reduced, and analyzed within this report in accordance with measurement guidelines set forth in the following reference standards and as outlined in National Technical Systems - Silicon Valley test procedures:

ANSI C63.10-2013

FCC DTS Measurement Guidance KDB558074

The intentional radiator above has been tested in a simulated typical installation to demonstrate compliance with the relevant Industry Canada performance and procedural standards.

Final system data was gathered in a mode that tended to maximize emissions by varying orientation of EUT, orientation of power and I/O cabling, antenna search height, and antenna polarization.

Every practical effort was made to perform an impartial test using appropriate test equipment of known calibration. All pertinent factors have been applied to reach the determination of compliance.

OBJECTIVE

The primary objective of the manufacturer is compliance with the regulations outlined in the previous section.

Prior to marketing in the USA, all unlicensed transmitters and transceivers require certification. Receive-only devices operating between 30 MHz and 960 MHz are subject to either certification or a manufacturer’s declaration of conformity, with all other receive-only devices exempt from the technical requirements.

Prior to marketing in Canada, Class I transmitters, receivers and transceivers require certification. Class II devices are required to meet the appropriate technical requirements but are exempt from certification requirements.

Certification is a procedure where the manufacturer submits test data and technical information to a certification body and receives a certificate or grant of equipment authorization upon successful completion of the certification body’s review of the submitted documents. Once the equipment authorization has been obtained, the label indicating compliance must be attached to all identical units, which are subsequently manufactured.

Maintenance of compliance is the responsibility of the manufacturer. Any modification of the product which may result in increased emissions should be checked to ensure compliance has been maintained (i.e., printed circuit board layout changes, different line filter, different power supply, harnessing or I/O cable changes, etc.).

STATEMENT OF COMPLIANCE

The tested sample of Pace Americas Inc. model 260-E255030 complied with the requirements of the following regulations:

Industry Canada RSS-Gen Issue 4

RSS 247 Issue 1 “Low-power Licence-exempt Radiocommunication Devices (All Frequency Bands): Category I Equipment”

FCC Part 15 Subpart C

Maintenance of compliance is the responsibility of the manufacturer. Any modifications to the product should be assessed to determine their potential impact on the compliance status of the device with respect to the standards detailed in this test report.

The test results recorded herein are based on a single type test of Pace Americas Inc. model 260-E255030 and therefore apply only to the tested sample. The sample was selected and prepared by Mark Rieger of Pace Americas Inc.

DEVIATIONS FROM THE STANDARDS

No deviations were made from the published requirements listed in the scope of this report.

TEST RESULTS SUMMARY

DIGITAL TRANSMISSION SYSTEMS (2400 – 2483.5MHz)

FCC Rule Part	Description	Measured Value / Comments	Limit / Requirement	Result
15.247(a)	Digital Modulation	Systems uses OFDM and DSSS techniques	System must utilize a digital transmission technology	Complies
15.247 (a) (2)	6dB Bandwidth	11b: 8.5 MHz 11g: 15.4 MHz n20: 15.6 MHz n40: 35.2 MHz	>500kHz	Complies
15.247 (b) (3)	Output Power (multipoint systems)	11b: 26.9dBm (-1.0dB) 11g: 27.5dBm (-.4dB) n20: 27.6dBm (-.3dB) n40: 21.2dBm (-6.7dB) Max EIRP = 3.72 W ^{Note 1}	1Watt, EIRP limited to 4 Watts.	Complies
15.247(d)	Power Spectral Density	11b: 6.5 dBm/3kHz (-1.5dB) 11g: 1.7 dBm/3kHz (-6.3dB) n20: 1.3 dBm/3kHz (-6.7dB) n40: -6.0 dBm/3kHz (-14.0dB)	8dBm/3kHz	Complies
15.247(c)	Antenna Port Spurious Emissions 30MHz – 25 GHz	All emissions < -30 dBc	< -30 dBc ^{Note 2}	Complies
15.247(c) / 15.209	Radiated Spurious Emissions 30MHz – 25 GHz	53.9 dBμV/m @ 2389.0 MHz (-0.1 dB)	15.207 in restricted bands, all others <-30dBc ^{Note 2}	Complies
Note 1: EIRP calculated using antenna gain of 2.3, 5.1 and 2.3 dBi for chains 1, 2 and 3 respectively for the highest EIRP system. Limit was reduced as the effective antenna gain was calculated as 8.1 dBi. Note 2: Limit of -30dBc used because the power was measured using the UNII test procedure (maximum power averaged over a transmission burst). Note 3: The device is operating under the smart antenna rules as detailed in FCC 15.247 (c) (2) / RSS 247 5.4 (6). Refer to the operational description for additional justification.				

GENERAL REQUIREMENTS APPLICABLE TO ALL BANDS

FCC Rule Part	Description	Measured Value / Comments	Limit / Requirement	Result (margin)
15.203	RF Connector	Module used U.FL board mount antenna connectors	Unique or integral antenna required	Complies
15.207	AC Conducted Emissions	39.4 dBμV @ 0.474 MHz (-7.0 dB)	Refer to page 19	Complies
15.247 (b) (5) / 15.407 (f)	RF Exposure Requirements	Refer to MPE calculations in separate exhibit	Refer to OET 65, FCC Part 1 and RSS 102	Complies

MEASUREMENT UNCERTAINTIES

ISO/IEC 17025 requires that an estimate of the measurement uncertainties associated with the emissions test results be included in the report. The measurement uncertainties given below are based on a 95% confidence level and were calculated in accordance with UKAS document LAB 34.

Measurement Type	Measurement Unit	Frequency Range	Expanded Uncertainty
RF power, conducted (power meter)	dBm	25 to 7000 MHz	± 0.52 dB
RF power, conducted (Spectrum analyzer)	dBm	25 to 7000 MHz	± 0.7 dB
Conducted emission of transmitter	dBm	25 to 26500 MHz	± 0.7 dB
Conducted emission of receiver	dBm	25 to 26500 MHz	± 0.7 dB
Radiated emission (substitution method)	dBm	25 to 26500 MHz	± 2.5 dB
Radiated emission (field strength)	dB μ V/m	25 to 1000 MHz	± 3.6 dB
		1000 to 40000 MHz	± 6.0 dB
Conducted Emissions (AC Power)	dB μ V	0.15 to 30 MHz	± 2.4 dB

EQUIPMENT UNDER TEST (EUT) DETAILS**GENERAL**

The Pace Americas Inc. model 260-E255030 is an 802.11bgn radio module that uses both 20 and 40 MHz nominal bandwidths.

The sample was received on January 5, 2016 and tested on January 5, 6 and 11, February 2, 4, 8, 9 and 10, 2016. The EUT tested was:

Company	Model	Description	Serial Number	FCC ID
Pace Americas, Inc.	260-E255030	Wi-Fi Module	PAV80000005	PGR2G4360M

OTHER EUT DETAILS

The following EUT details should be noted: The EUT operates with all 3 chains in both legacy and MIMO modes.

ANTENNA SYSTEM

The antenna system consists of three PCB antennas with attached coaxial cables for connection to the module.

ENCLOSURE

The EUT has no enclosure. The PCB measures 7 cm by 7 cm. It is designed to be installed within the enclosure of a host.

MODIFICATIONS

No modifications were made to the EUT during the time the product was at NTS Silicon Valley.

SUPPORT EQUIPMENT

The following equipment was used as support equipment for testing:

Company	Model	Description	Serial Number	FCC ID
Delta	ADP-66DR A	Power Adapter	HUGD5B9005J	-
Pace	-	Interface board	-	-

The following equipment was used as remote support equipment for emissions testing:

Company	Model	Description	Serial Number	FCC ID
Dell	Latitude D610	Laptop	6XYYQ91	-

EUT INTERFACE PORTS

The I/O cabling configuration during testing was as follows:

Port	Connected To	Description	Cable(s)	
			Shielded or Unshielded	Length(m)
Antenna port (x3)	Antenna	Coax	Shielded	Varies, Integral to antenna

The module connects to the interface board via PCI-E connector.

The cabling configuration of the support equipment used during testing was as follows:

Port	Connected To	Description	Cable(s)	
			Shielded or Unshielded	Length(m)
Interface board serial	Remote Laptop	Adapter to Dsub and standard serial	Unshielded Shielded	10
Interface board Ethernet	Remote Laptop	Cat 5	Unshielded	10

EUT OPERATION

During testing, the EUT was configured to transmit continuously on the selected channel, in the selected mode at the maximum power.

TEST SITE**GENERAL INFORMATION**

Final test measurements were taken at the test sites listed below. Pursuant to section 2.948 of the FCC's Rules and section 3.3 of RSP-100, construction, calibration, and equipment data has been filed with the Commission and with industry Canada.

Site	Designation / Registration Numbers		Location
	FCC	Canada	
Chamber 7	US0027	2845B-7	41039 Boyce Road Fremont, CA 94538-2435

ANSI C63.4 recommends that ambient noise at the test site be at least 6 dB below the allowable limits. Ambient levels are below this requirement. The test site(s) contain separate areas for radiated and conducted emissions testing. Considerable engineering effort has been expended to ensure that the facilities conform to all pertinent requirements of ANSI C63.4.

CONDUCTED EMISSIONS CONSIDERATIONS

Conducted emissions testing is performed in conformance with ANSI C63.10. Measurements are made with the EUT connected to the public power network through a nominal, standardized RF impedance, which is provided by a line impedance stabilization network, known as a LISN. A LISN is inserted in series with each current-carrying conductor in the EUT power cord.

RADIATED EMISSIONS CONSIDERATIONS

The FCC has determined that radiation measurements made in a shielded enclosure are not suitable for determining levels of radiated emissions. Radiated measurements are performed in an open field environment or in a semi-anechoic chamber. The test sites are maintained free of conductive objects within the CISPR defined elliptical area incorporated in ANSI C63.4 guidelines and meet the Normalized Site Attenuation (NSA) requirements of ANSI C63.4.

MEASUREMENT INSTRUMENTATION

RECEIVER SYSTEM

An EMI receiver as specified in CISPR 16-1-1 is used for emissions measurements. The receivers used can measure over the frequency range of 9 kHz up to 2000 MHz. These receivers allow both ease of measurement and high accuracy to be achieved. The receivers have Peak, Average, and CISPR (Quasi-peak) detectors built into their design so no external adapters are necessary. The receiver automatically sets the required bandwidth for the CISPR detector used during measurements. If the repetition frequency of the signal being measured is below 20Hz, peak measurements are made in lieu of Quasi-Peak measurements.

For measurements above the frequency range of the receivers, a spectrum analyzer is utilized because it provides visibility of the entire spectrum along with the precision and versatility required to support engineering analysis. Average measurements above 1000MHz are performed on the spectrum analyzer using the linear-average method with a resolution bandwidth of 1 MHz and a video bandwidth of 10 Hz, unless the signal is pulsed in which case the average (or video) bandwidth of the measuring instrument is reduced to onset of pulse desensitization and then increased.

INSTRUMENT CONTROL COMPUTER

Software is used to view and convert receiver measurements to the field strength at an antenna or voltage developed at the LISN measurement port, which is then compared directly with the appropriate specification limit. This provides faster, more accurate readings by performing the conversions described under Sample Calculations within the Test Procedures section of this report. Results are printed in a graphic and/or tabular format, as appropriate. A personal computer is used to record all measurements made with the receivers. The software used for radiated and conducted emissions measurements is NTS EMI Test Software (rev 2.10)

LINE IMPEDANCE STABILIZATION NETWORK (LISN)

Line conducted measurements utilize a fifty microhenry Line Impedance Stabilization Network as the monitoring point. The LISN used also contains a 250 uH CISPR adapter. This network provides for calibrated radio frequency noise measurements by the design of the internal low pass and high pass filters on the EUT and measurement ports, respectively.

FILTERS/ATTENUATORS

External filters and precision attenuators are often connected between the receiving antenna or LISN and the receiver. This eliminates saturation effects and non-linear operation due to high amplitude transient events.

ANTENNAS

A loop antenna is used below 30 MHz. For the measurement range 30 MHz to 1000 MHz either a combination of a biconical antenna and a log periodic or a bi-log antenna is used. Above 1000 MHz, horn antennas are used. The antenna calibration factors to convert the received voltage to an electric field strength are included with appropriate cable loss and amplifier gain factors to determine an overall site factor, which is then programmed into the test receivers or incorporated into the test software.

ANTENNA MAST AND EQUIPMENT TURNTABLE

The antennas used to measure the radiated electric field strength are mounted on a non-conductive antenna mast equipped with a motor-drive to vary the antenna height. Measurements below 30 MHz are made with the loop antenna at a fixed height of 1m above the ground plane.

ANSI C63.10 specifies that the test height above ground for table mounted devices shall be 80 centimeters. Floor mounted equipment shall be placed on the ground plane if the device is normally used on a conductive floor or separated from the ground plane by insulating material from 3 to 12 mm if the device is normally used on a non-conductive floor as specified in ANSI C63.4. During radiated measurements, the EUT is positioned on a motorized turntable in conformance with this requirement.

INSTRUMENT CALIBRATION

All test equipment is regularly checked to ensure that performance is maintained in accordance with the manufacturer's specifications. All antennas are calibrated at regular intervals with respect to tuned half-wave dipoles. An exhibit of this report contains the list of test equipment used and calibration information.

TEST PROCEDURES

EUT AND CABLE PLACEMENT

The regulations require that interconnecting cables be connected to the available ports of the unit and that the placement of the unit and the attached cables simulate the worst case orientation that can be expected from a typical installation, so far as practicable. To this end, the position of the unit and associated cabling is varied within the guidelines of ANSI C63.10, and the worst-case orientation is used for final measurements.

CONDUCTED EMISSIONS

Conducted emissions are measured at the plug end of the power cord supplied with the EUT. Excess power cord length is wrapped in a bundle between 30 and 40 centimeters in length near the center of the cord. Preliminary measurements are made to determine the highest amplitude emission relative to the specification limit for all the modes of operation. Placement of system components and varying of cable positions are performed in each mode. A final peak mode scan is then performed in the position and mode for which the highest emission was noted on all current carrying conductors of the power cord.

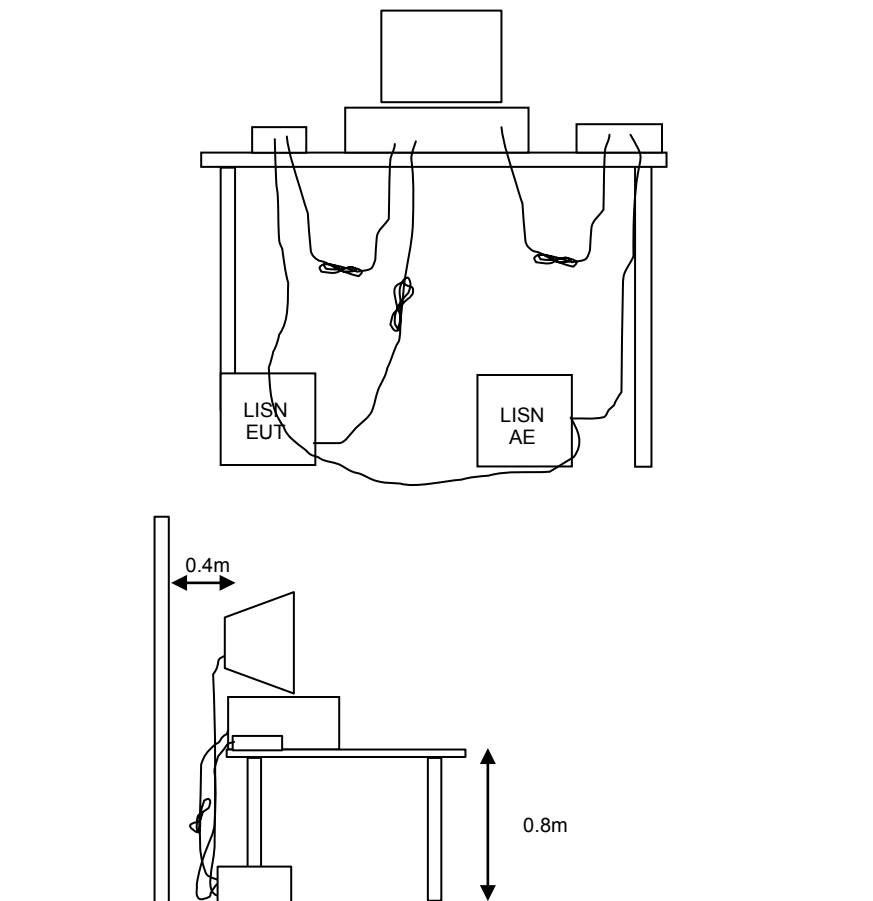

Figure 1 Typical Conducted Emissions Test Configuration

RADIATED EMISSIONS

A preliminary scan of the radiated emissions is performed in which all significant EUT frequencies are identified with the system in a nominal configuration. At least two scans are performed, one scan for each antenna polarization (horizontal and vertical; loop parallel and perpendicular to the EUT). During the preliminary scans, the EUT is rotated through 360°, the antenna height is varied (for measurements above 30 MHz) and cable positions are varied to determine the highest emission relative to the limit. Preliminary scans may be performed in a fully anechoic chamber for the purposes of identifying the frequencies of the highest emissions from the EUT.

A speaker is provided in the receiver to aid in discriminating between EUT and ambient emissions. Other methods used during the preliminary scan for EUT emissions involve scanning with near field magnetic loops, monitoring I/O cables with RF current clamps, and cycling power to the EUT.

Final maximization is a phase in which the highest amplitude emissions identified in the spectral search are viewed while the EUT azimuth angle is varied from 0 to 360 degrees relative to the receiving antenna. The azimuth, which results in the highest emission is then maintained while varying the antenna height from one to four meters (for measurements above 30 MHz, measurements below 30 MHz are made with the loop antenna at a fixed height of 1m). The result is the identification of the highest amplitude for each of the highest peaks. Each recorded level is corrected in the receiver using appropriate factors for cables, connectors, antennas, and preamplifier gain.

When testing above 18 GHz, the receive antenna is located at 1 meter from the EUT and the antenna height is restricted to a maximum of 2.5 meters.

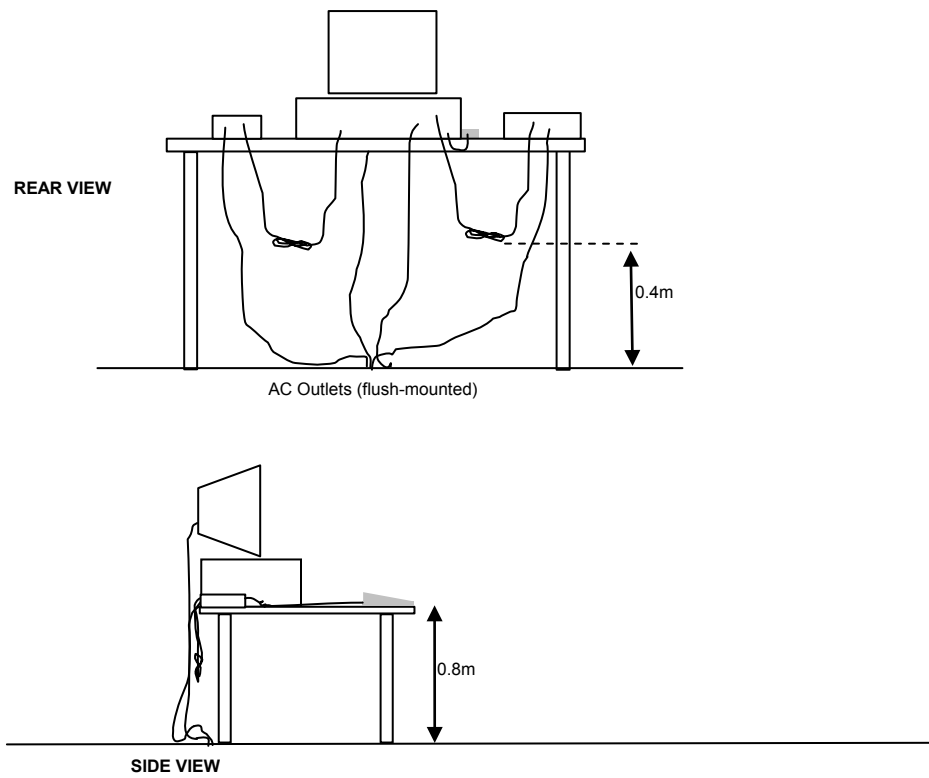

Typical Test Configuration for Radiated Field Strength Measurements

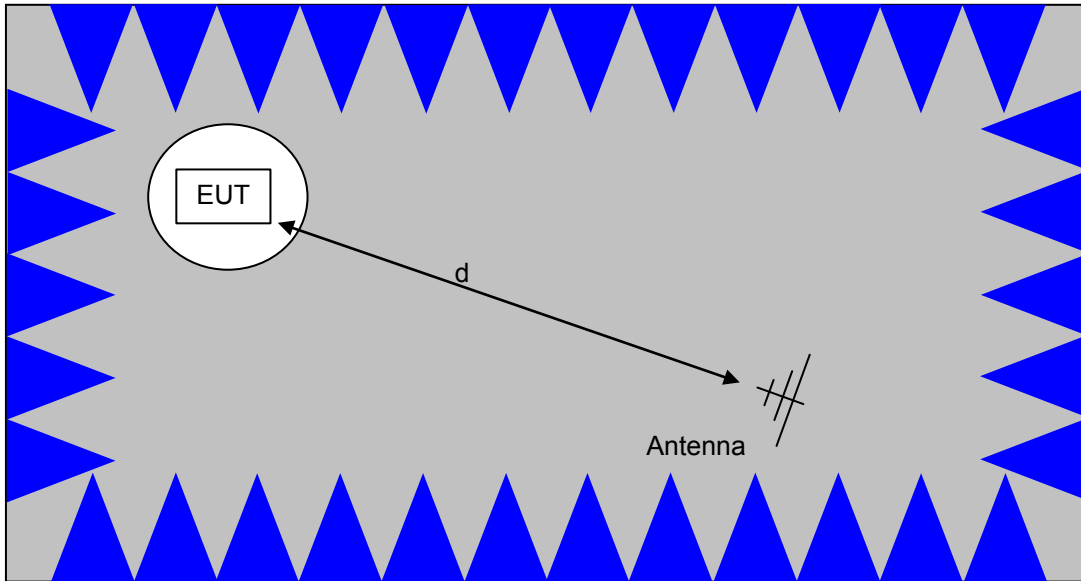

The anechoic materials on the walls and ceiling ensure compliance with the normalized site attenuation requirements of CISPR 16 / CISPR 22 / ANSI C63.4 for an alternate test site at the measurement distances used.

Floor-standing equipment is placed on the floor with insulating supports between the unit and the ground plane.

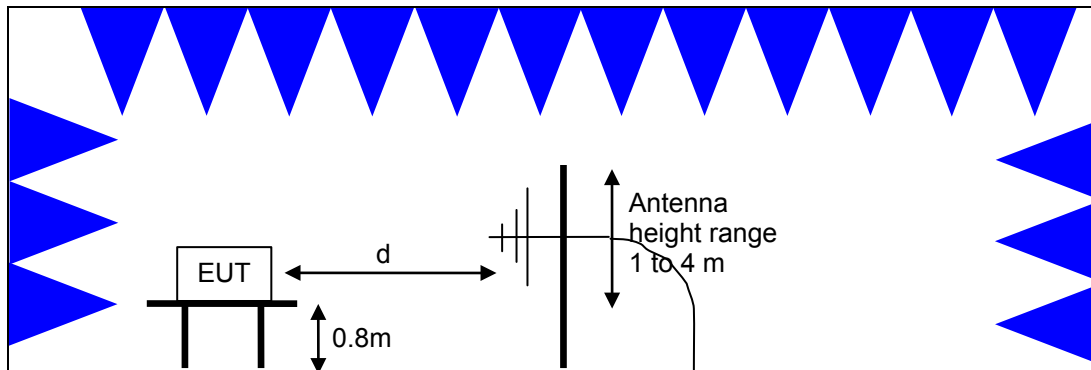

Test Configuration for Radiated Field Strength Measurements
Semi-Anechoic Chamber, Plan and Side Views

CONDUCTED EMISSIONS FROM ANTENNA PORT

Direct measurements of power, bandwidth and power spectral density are performed, where possible, with the antenna port of the EUT connected to either the power meter or spectrum analyzer via a suitable attenuator and/or filter. These are used to ensure that the front end of the measurement instrument is not overloaded by the fundamental transmission.

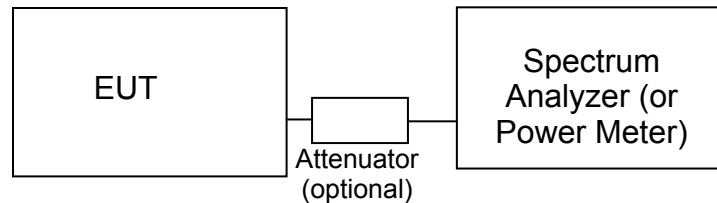
Test Configuration for Antenna Port Measurements

Measurement bandwidths (video and resolution) are set in accordance with the relevant standards and NTS Silicon Valley's test procedures for the type of radio being tested. When power measurements are made using a resolution bandwidth less than the signal bandwidth the power is calculated by summing the power across the signal bandwidth using either the analyzer channel power function or by capturing the trace data and calculating the power using software. In both cases the summed power is corrected to account for the equivalent noise bandwidth (ENBW) of the resolution bandwidth used.

If power averaging is used (typically for certain digital modulation techniques), the EUT is configured to transmit continuously. Power averaging is performed using either the built-in function of the analyzer or, if the analyzer does not feature power averaging, using external software. In both cases the average power is calculated over a number of sweeps (typically 100). When the EUT cannot be configured to continuously transmit then either the analyzer is configured to perform a gated sweep to ensure that the power is averaged over periods that the device is transmitting or power averaging is disabled and a max-hold feature is used.

If a power meter is used to make output power measurements the sensor head type (peak or average) is stated in the test data table.

BANDWIDTH MEASUREMENTS

The 6dB, 20dB, 26dB and/or 99% signal bandwidth are measured using the bandwidths recommended by ANSI C63.10 and RSS GEN.

SPECIFICATION LIMITS AND SAMPLE CALCULATIONS

The limits for conducted emissions are given in units of microvolts, and the limits for radiated emissions are given in units of microvolts per meter at a specified test distance. Data is measured in the logarithmic form of decibels relative to one microvolt, or dB microvolts (dBuV). For radiated emissions, the measured data is converted to the field strength at the antenna in dB microvolts per meter (dBuV/m). The results are then converted to the linear forms of uV and uV/m for comparison to published specifications.

For reference, converting the specification limits from linear to decibel form is accomplished by taking the base ten logarithm, then multiplying by 20. These limits in both linear and logarithmic form are as follows:

CONDUCTED EMISSIONS SPECIFICATION LIMITS: FCC 15.207; FCC 15.107(a), RSS GEN

The table below shows the limits for the emissions on the AC power line from an intentional radiator and a receiver.

Frequency (MHz)	Average Limit (dBuV)	Quasi Peak Limit (dBuV)
0.150 to 0.500	Linear decrease on logarithmic frequency axis between 56.0 and 46.0	Linear decrease on logarithmic frequency axis between 66.0 and 56.0
0.500 to 5.000	46.0	56.0
5.000 to 30.000	50.0	60.0

GENERAL TRANSMITTER RADIATED EMISSIONS SPECIFICATION LIMITS

The table below shows the limits for the spurious emissions from transmitters that fall in restricted bands¹ (with the exception of transmitters operating under FCC Part 15 Subpart D and RSS 210 Annex 9), the limits for all emissions from a low power device operating under the general rules of RSS 310 (tables 3 and 4), RSS 210 (table 2) and FCC Part 15 Subpart C section 15.209.

Frequency Range (MHz)	Limit (uV/m)	Limit (dBuV/m @ 3m)
0.009-0.490	2400/F _{KHz} @ 300m	67.6-20*log ₁₀ (F _{KHz}) @ 300m
0.490-1.705	24000/F _{KHz} @ 30m	87.6-20*log ₁₀ (F _{KHz}) @ 30m
1.705 to 30	30 @ 30m	29.5 @ 30m
30 to 88	100 @ 3m	40 @ 3m
88 to 216	150 @ 3m	43.5 @ 3m
216 to 960	200 @ 3m	46.0 @ 3m
Above 960	500 @ 3m	54.0 @ 3m

RECEIVER RADIATED SPURIOUS EMISSIONS SPECIFICATION LIMITS

The table below shows the limits for the spurious emissions from receivers as detailed in FCC Part 15.109, RSS 210 Table 2, RSS GEN Table 1 and RSS 310 Table 3. Note that receivers operating outside of the frequency range 30 MHz – 960 MHz are exempt from the requirements of 15.109.

Frequency Range (MHz)	Limit (uV/m @ 3m)	Limit (dBuV/m @ 3m)
30 to 88	100	40
88 to 216	150	43.5
216 to 960	200	46.0
Above 960	500	54.0

OUTPUT POWER LIMITS – DIGITAL TRANSMISSION SYSTEMS

The table below shows the limits for output power and output power density. Where the signal bandwidth is less than 20 MHz the maximum output power is reduced to the power spectral density limit plus 10 times the log of the bandwidth (in MHz).

Operating Frequency (MHz)	Output Power	Power Spectral Density
902 – 928	1 Watt (30 dBm)	8 dBm/3kHz
2400 – 2483.5	1 Watt (30 dBm)	8 dBm/3kHz
5725 – 5850	1 Watt (30 dBm)	8 dBm/3kHz

¹ The restricted bands are detailed in FCC 15.203, RSS 210 Table 1 and RSS 310 Table 2

The maximum permitted output power is reduced by 1dB for every dB the antenna gain exceeds 6dBi. Fixed point-to-point applications using the 5725 – 5850 MHz band are not subject to this restriction.

TRANSMIT MODE SPURIOUS RADIATED EMISSIONS LIMITS – FHSS and DTS SYSTEMS

The limits for unwanted (spurious) emissions from the transmitter falling in the restricted bands are those specified in the general limits sections of FCC Part 15 and RSS 210. All other unwanted (spurious) emissions shall be at least 20dB below the level of the highest in-band signal level (30dB if the power is measured using the sample detector/power averaging method).

SAMPLE CALCULATIONS - CONDUCTED EMISSIONS

Receiver readings are compared directly to the conducted emissions specification limit (decibel form) as follows:

$$R_r - S = M$$

where:

R_r = Receiver Reading in dBuV

S = Specification Limit in dBuV

M = Margin to Specification in +/- dB

SAMPLE CALCULATIONS - RADIATED EMISSIONS

Receiver readings are compared directly to the specification limit (decibel form). The receiver internally corrects for cable loss, preamplifier gain, and antenna factor. The calculations are in the reverse direction of the actual signal flow, thus cable loss is added and the amplifier gain is subtracted. The Antenna Factor converts the voltage at the antenna coaxial connector to the field strength at the antenna elements.

A distance factor, when used for electric field measurements above 30MHz, is calculated by using the following formula:

$$F_d = 20 * \text{LOG}_{10} (D_m/D_s)$$

where:

F_d = Distance Factor in dB

D_m = Measurement Distance in meters

D_s = Specification Distance in meters

For electric field measurements below 30MHz the extrapolation factor is either determined by making measurements at multiple distances or a theoretical value is calculated using the formula:

$$F_d = 40 * \text{LOG}_{10} (D_m/D_s)$$

Measurement Distance is the distance at which the measurements were taken and Specification Distance is the distance at which the specification limits are based. The antenna factor converts the voltage at the antenna coaxial connector to the field strength

at the antenna elements.

GENERAL TRANSMITTER RADIATED EMISSIONS SPECIFICATION LIMITS

The table below shows the limits for the spurious emissions from transmitters that fall in restricted bands².

Frequency Range (MHz)	Limit (uV/m)	Limit (dBuV/m @ 3m)
0.009-0.490	2400/F _{KHz} @ 300m	67.6-20*log ₁₀ (F _{KHz}) @ 300m
0.490-1.705	24000/F _{KHz} @ 30m	87.6-20*log ₁₀ (F _{KHz}) @ 30m
1.705 to 30	30 @ 30m	29.5 @ 30m
30 to 88	100 @ 3m	40 @ 3m
88 to 216	150 @ 3m	43.5 @ 3m
216 to 960	200 @ 3m	46.0 @ 3m
Above 960	500 @ 3m	54.0 @ 3m

RECEIVER RADIATED SPURIOUS EMISSIONS SPECIFICATION LIMITS

The table below shows the limits for the spurious emissions from receivers as detailed in FCC Part 15.109 and RSS GEN Table 2. Note that receivers operating outside of the frequency range 30 MHz – 960 MHz are exempt from the requirements of 15.109 and receivers that are not stand-alone are exempt from the ISED Canada requirements per RSS-GEN.

Frequency Range (MHz)	Limit (uV/m @ 3m)	Limit (dBuV/m @ 3m)
30 to 88	100	40
88 to 216	150	43.5
216 to 960	200	46.0
Above 960	500	54.0

² The restricted bands are detailed in FCC 15.205 and RSS-Gen Table 6

OUTPUT POWER LIMITS – DIGITAL TRANSMISSION SYSTEMS

The table below shows the limits for output power and output power density. Where the signal bandwidth is less than 20 MHz the maximum output power is reduced to the power spectral density limit plus 10 times the log of the bandwidth (in MHz).

Operating Frequency (MHz)	Output Power	Power Spectral Density
902 – 928	1 Watt (30 dBm)	8 dBm/3kHz
2400 – 2483.5	1 Watt (30 dBm)	8 dBm/3kHz
5725 – 5850	1 Watt (30 dBm)	8 dBm/3kHz

The maximum permitted output power is reduced by 1dB for every dB the antenna gain exceeds 6dBi. Fixed point-to-point applications using the 5725 – 5850 MHz band are not subject to this restriction.

OUTPUT POWER LIMITS – FHSS SYSTEMS

The table below shows the limits for output power based on the number of channels available for the hopping system.

Operating Frequency (MHz)	Number of Channels	Output Power
902 – 928	≥ 50	1 Watt (30 dBm)
902 – 928	25 to 49	0.25 Watts (24 dBm)
2400 – 2483.5	≥ 75	1 Watt (30 dBm)
2400 – 2483.5	< 75	0.125 Watts (21 dBm)
5725 – 5850	75	1 Watt (30 dBm)

The maximum permitted output power is reduced by 1dB for every dB the antenna gain exceeds 6dBi. Fixed point-to-point applications using the 5725 – 5850 MHz band are not subject to this restriction.

TRANSMIT MODE SPURIOUS RADIATED EMISSIONS LIMITS – FHSS and DTS SYSTEMS

The limits for unwanted (spurious) emissions from the transmitter falling in the restricted bands are those specified in the general limits sections of FCC Part 15 and RSS 210. All other unwanted (spurious) emissions shall be at least 20dB below the level of the highest in-band signal level (30dB if the power is measured using the sample detector/power averaging method).

FCC 15.407 (a) OUTPUT POWER LIMITS

The table below shows the limits for output power and output power density. For the 5250-5350 and 5470-5725 MHz bands, where the signal bandwidth is less than 20 MHz the maximum output power is reduced to the power spectral density limit plus 10 times the log of the bandwidth (in MHz).

Operating Frequency (MHz)	Output Power	Power Spectral Density
5150 – 5250	1Watt (30 dBm)	17 dBm/MHz
5250 – 5350 and 5470-5725	250 mW (24 dBm)	11 dBm/MHz
5725 – 5825	1 Watt (30 dBm)	30 dBm/500kHz

For system using antennas with gains exceeding 6dBi, the output power and power spectral density limits are reduced by 1dB for every dB the antenna gain exceeds 6dBi. Fixed point-to-point applications using the 5725 – 5825 MHz band may use antennas with gains of up to 23dBi without this limitation. If the gain exceeds 23dBi then the output power limit of 1 Watt is reduced by 1dB for every dB the gain exceeds 23dBi.

OUTPUT POWER LIMITS –LELAN DEVICES

The table below shows the limits for output power and output power density defined by RSS 247. Where the signal bandwidth is less than 20 MHz the maximum output power is reduced to the power spectral density limit plus 10 times the log of the bandwidth (in MHz).

Operating Frequency (MHz)	Output Power	Power Spectral Density
5150 – 5250	200mW (23 dBm) eirp	10 dBm/MHz eirp
5250 – 5350 and 5470 - 5725	250 mW (24 dBm) ³ 1W (30dBm) eirp	11 dBm/MHz
5725 – 5825	1 Watt (30 dBm) 4W eirp	30 dBm/500kHz

Fixed point-to-point applications using the 5725 – 5825 MHz band may use antennas with gains of up to 23dBi without this limitation. If the gain exceeds 23dBi then the output power limit of 1 Watt is reduced by 1dB for every dB the gain exceeds 23dBi.

SPURIOUS EMISSIONS LIMITS –UNII and LELAN DEVICES

The spurious emissions limits for signals below 1GHz are the FCC/RSS-GEN general limits. For emissions above 1GHz, signals in restricted bands are subject to the FCC/RSS GEN general limits. All other signals have a limit of –27dBm/MHz, which is a field strength of 68.3dBuV/m/MHz at a distance of 3m. For devices operating in the 5725-5850MHz bands under the LELAN/UNII rules, the limit within 10MHz of the allocated band is increased to –17dBm/MHz.

³ If EIRP exceeds 500mW the device must employ TPC

SAMPLE CALCULATIONS - CONDUCTED EMISSIONS

Receiver readings are compared directly to the conducted emissions specification limit (decibel form) as follows:

$$R_r - S = M$$

where:

R_r = Receiver Reading in dBuV

S = Specification Limit in dBuV

M = Margin to Specification in +/- dB

SAMPLE CALCULATIONS - RADIATED EMISSIONS

Receiver readings are compared directly to the specification limit (decibel form). The receiver internally corrects for cable loss, preamplifier gain, and antenna factor. The calculations are in the reverse direction of the actual signal flow, thus cable loss is added and the amplifier gain is subtracted. The Antenna Factor converts the voltage at the antenna coaxial connector to the field strength at the antenna elements.

A distance factor, when used for electric field measurements above 30MHz, is calculated by using the following formula:

$$F_d = 20 * \text{LOG}_{10} (D_m/D_s)$$

where:

F_d = Distance Factor in dB

D_m = Measurement Distance in meters

D_s = Specification Distance in meters

For electric field measurements below 30MHz the extrapolation factor is either determined by making measurements at multiple distances or a theoretical value is calculated using the formula:

$$F_d = 40 * \text{LOG}_{10} (D_m/D_s)$$

Measurement Distance is the distance at which the measurements were taken and Specification Distance is the distance at which the specification limits are based. The antenna factor converts the voltage at the antenna coaxial connector to the field strength at the antenna elements.

The margin of a given emission peak relative to the limit is calculated as follows:

$$R_c = R_r + F_d$$

and

$$M = R_c - L_s$$

where:

R_r = Receiver Reading in dBuV/m

F_d = Distance Factor in dB

R_c = Corrected Reading in dBuV/m

L_s = Specification Limit in dBuV/m

M = Margin in dB Relative to Spec

SAMPLE CALCULATIONS - FIELD STRENGTH TO EIRP CONVERSION

Where the radiated electric field strength is expressed in terms of the equivalent isotropic radiated power (eirp), or where a field strength measurement of output power is made in lieu of a direct measurement, the following formula is used to convert between eirp and field strength at a distance of d (meters) from the equipment under test:

$$E = \frac{1000000 \sqrt{30 P}}{d} \quad \text{microvolts per meter}$$

where P is the eirp (Watts)

For a measurement at 3m the conversion from a logarithmic value for field strength (dBuV/m) to an eirp power (dBm) is -95.3dB.

Appendix A Test Equipment Calibration Data

<u>Manufacturer</u>	<u>Description</u>	<u>Model</u>	<u>Asset #</u>	<u>Calibrated</u>	<u>Cal Due</u>
Radiated Emissions, 1000 - 25000 MHz, 05-Jan-16					
EMCO	Antenna, Horn, 1-18GHz	3115	868	6/26/2014	6/26/2016
HP / Miteq	SA40 Head (Purple)	TTA1840-45-5P-HG-S	1772	12/21/2015	12/21/2016
A. H. Systems	Spare System Horn, 18-40GHz	SAS-574, p/n: 2581	2162	7/29/2015	7/29/2017
Hewlett Packard	Microwave Preamplifier, 1-26.5GHz	8449B	2199	10/9/2015	10/9/2016
Micro-Tronics	Band Reject Filter, 2400-2500 MHz	BRM50702-02	2249	9/16/2015	9/16/2016
Hewlett Packard	Spectrum Analyzer (SA40) Purple 9 kHz - 40 GHz,	8564E (84125C)	2415	3/7/2015	3/7/2016
Radiated Emissions, 1,000 - 25,000 MHz, 06-Jan-16					
EMCO	Antenna, Horn, 1-18 GHz	3115	487	7/29/2014	7/29/2016
Hewlett Packard	Microwave Preamplifier, 1-26.5GHz	8449B	870	2/20/2015	2/20/2016
Hewlett Packard	Spectrum Analyzer (SA40) Red 30 Hz -40 GHz	8564E (84125C)	1148	10/17/2015	10/17/2016
Rohde & Schwarz	EMI Test Receiver, 20 Hz-7 GHz	ESIB7	1538	12/19/2015	12/19/2016
A. H. Systems	Purple System Horn, 18-40GHz	SAS-574, p/n: 2581	2160	8/28/2014	8/28/2017
Micro-Tronics	Band Reject Filter, 2400-2500 MHz	BRM50702-02	2249	9/16/2015	9/16/2016
Radiated Emissions, 30 - 1,000 MHz, 11-Jan-16					
Rohde & Schwarz	EMI Test Receiver, 20 Hz-7 GHz	ESIB7	1538	12/19/2015	12/19/2016
Sunol Sciences	Biconilog, 30-3000 MHz	JB3	1549	6/2/2015	6/2/2017
Hewlett Packard	9KHz-1300MHz pre-amp	8447F	2777	3/4/2015	3/5/2016
Radiated Emissions, 1000 - 2500 MHz, 02-Feb-16					
EMCO	Antenna, Horn, 1-18GHz	3115	868	6/26/2014	6/26/2016
Rohde & Schwarz	EMI Test Receiver, 20 Hz-7 GHz	ESIB7	1538	12/19/2015	12/19/2016
Radiated Emissions, 1000 - 25000 MHz, 04-Feb-16					
Rohde & Schwarz	EMI Test Receiver, 20 Hz-7 GHz	ESIB7	1538	12/19/2015	12/19/2016
EMCO	Antenna, Horn, 1-18 GHz	3115	1561	6/27/2014	6/27/2016
HP / Miteq	SA40 Head (Purple)	TTA1840-45-5P-HG-S	1772	12/21/2015	12/21/2016
A. H. Systems	Spare System Horn, 18-40GHz	SAS-574, p/n: 2581	2162	7/29/2015	7/29/2017
Hewlett Packard	Microwave Preamplifier, 1-26.5GHz	8449B	2199	10/9/2015	10/9/2016
Hewlett Packard	Spectrum Analyzer (SA40) Purple 9 kHz - 40 GHz,	8564E (84125C)	2415	3/7/2015	3/7/2016
Radio Antenna Port (Power and Spurious Emissions), 08-10-Feb-16					
Rohde & Schwarz	Signal Analyzer 20 Hz - 26.5 GHz	FSQ26	2327	5/6/2015	5/6/2016



<u>Manufacturer</u>	<u>Description</u>	<u>Model</u>	<u>Asset #</u>	<u>Calibrated</u>	<u>Cal Due</u>
Rohde & Schwarz	Open Switch and Control Unit, p/s	OSP120 with B157	3000	6/8/2015	6/8/2016
Conducted Emissions - AC Power Ports, 11-Jan-16					
Rohde & Schwarz	Pulse Limiter	ESH3 Z2	1401	5/14/2015	5/14/2016
Rohde & Schwarz	EMI Test Receiver, 20 Hz-7 GHz	ESIB7	1538	12/19/2015	12/19/2016
Com-Power	9KHz-30MHz, 50uH, 15Aac, 10Adc, max CISPR 15	LI-215A	2671	5/26/2015	5/26/2016

Appendix B Test Data

T100355 Pages 30 – 135



EMC Test Data

Client:	Pace Americas, Inc.	Job Number:	JD100298
Product:	Wi-Fi Module 2.4 GHz	T-Log Number:	T100355
System Configuration:		Project Manager:	Irene Radamacher
Contact:	Mark Rieger	Project Coordinator:	
Emissions Standard(s):	FCC Part 15.247	Class:	N/A
Immunity Standard(s):		Environment:	Radio

EMC Test Data

For The

Pace Americas, Inc.

Product

Wi-Fi Module 2.4 GHz

Date of Last Test: 2/11/2016



EMC Test Data

Client: Pace Americas, Inc.	Job Number: JD100298
Model: Wi-Fi Module 2.4 GHz	T-Log Number: T100355
	Project Manager: Irene Radamacher
Contact: Mark Rieger	Project Coordinator: -
Standard: FCC Part 15.247	Class: N/A

Power vs. Data Rate

In normal operating modes the card uses power settings stored on EEPROM to set the output power. For a given nominal output power the actual transmit power normally is reduced as the data rate increases, therefore testing was performed at the data rate in the mode with highest power to determine compliance with the requirements.

The following power measurements were made using a average power meter and with the device configured in a continuous transmit mode on Chain 1 at the various data rates in each mode to verify the highest power mode:

Sample Notes

Sample S/N: F55154470184

Driver: 7.14.89.21.571.206

Date of Test: 1/4/2016

Test Engineer: David Bare

Test Location: Fremont Chamber #7

Mode	Data Rate	Power (dBm)	Power setting
802.11b	1	18.7	20.0
	2	19.2	
	5.5	19.2	
	11	19.2	
802.11g	6	18.6	20.0
	9	18.6	
	12	18.6	
	18	18.6	
	24	18.5	
	36	18.5	
	48	18.5	
	54	18.5	



EMC Test Data

Client:	Pace Americas, Inc.	Job Number:	JD100298
Model:	Wi-Fi Module 2.4 GHz	T-Log Number:	T100355
		Project Manager:	Irene Radamacher
Contact:	Mark Rieger	Project Coordinator:	-
Standard:	FCC Part 15.247	Class:	N/A

Mode	Data Rate	Power (dBm)	Power setting
802.11n/ac 20MHz	6.5	18.8	20.0
	13	18.8	
	19.5	18.7	
	26	18.6	
	39	18.6	
	52	18.6	
	58.5	18.6	
	65	18.5	
	78	18.5	<<-11 ac mode only
802.11n/ac 40MHz	13.5	19.1	20.0
	27	19.1	
	40.5	19.0	
	54	18.9	
	81	18.8	
	108	18.8	
	121.5	18.7	
	135	18.7	
	162	18.6	
	180	18.6	

Note : Power setting - the software power setting used during testing, included for reference only.

Client: Pace Americas, Inc.	Job Number: JD100298
Model: Wi-Fi Module 2.4 GHz	T-Log Number: T100355
	Project Manager: Irene Radamacher
Contact: Mark Rieger	Project Coordinator: -
Standard: FCC Part 15.247	Class: N/A

Duty Cycle

Date of Test: 1/4/2016
 Test Engineer: David Bare
 Test Location: Fremont Chamber #7

Non Beamforming Duty Cycles

Duty cycle measurements performed on the worse case data rate for power.

Mode	Data Rate	Duty Cycle (x)	Constant DC?	T (ms)	Pwr Cor Factor*	Lin Volt Cor Factor**	Min VBW for FS (Hz)
11b	2 Mb/s	1.00	Yes	10	0.0	0.0	10
11g	6 Mb/s	0.99	Yes	2.157	0.0	0.0	10
n20	MCS 0	0.98	Yes	2.018	0.0	0.0	10
n40	MCS 0	0.90	Yes	1.249	0.4	0.9	801

* Correction factor when using RMS/Power averaging - $10 \cdot \log(1/x)$

** Correction factor when using linear voltage average - $20 \cdot \log(1/x)$

T = Minimum transmission duration



EMC Test Data

Client: Pace Americas, Inc.	Job Number: JD100298
Model: Wi-Fi Module 2.4 GHz	T-Log Number: T100355
	Project Manager: Irene Radamacher
Contact: Mark Rieger	Project Coordinator: -
Standard: FCC Part 15.247	Class: N/A

Duty Cycle

Date of Test: 2/2/2016
 Test Engineer: Eddie Mariscal
 Test Location: Fremont Chamber #7

Beamforming Duty Cycles

Duty cycle measurements performed on the worse case data rate for power.

Notes: Measurements taken with maximum RBW and reduced VBW settings to obtain values for duty cycle.

Mode	Data Rate	Duty Cycle (x)	Constant DC?	T (ms)	Pwr Cor Factor*	Lin Volt Cor Factor**	Min VBW for FS (Hz)
n20	MCS 0	0.97	Yes	3.841	0.1	0.3	260
n40	MCS 0	0.97	Yes	4.575	0.1	0.2	219

* Correction factor when using RMS/Power averaging - $10 \cdot \log(1/x)$

** Correction factor when using linear voltage average - $20 \cdot \log(1/x)$

T = Minimum transmission duration

Client: Pace Americas, Inc.	Job Number: JD100298
Model: Wi-Fi Module 2.4 GHz	T-Log Number: T100355
Contact: Mark Rieger	Project Manager: Irene Radamacher
Standard: FCC Part 15.247	Project Coordinator: -
	Class: N/A

2.4GHz HT20 Plots

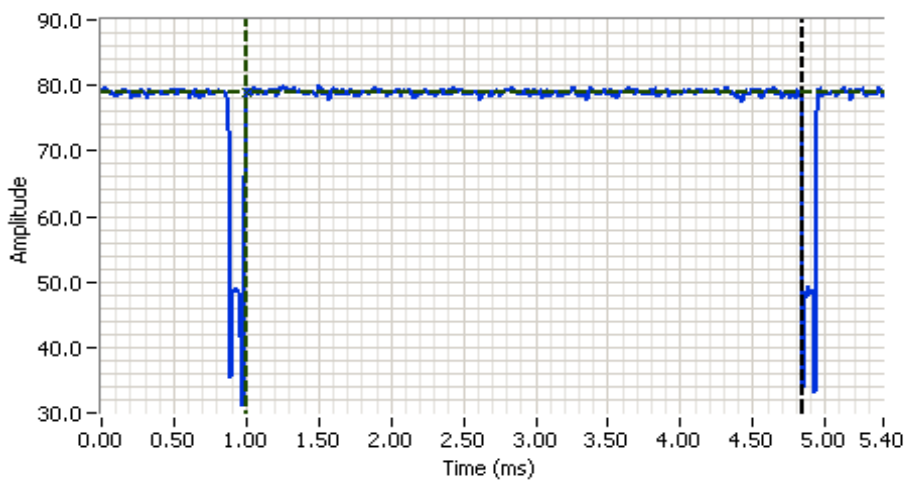

Analyzer Settings
 Rohde&Schwarz,ESI
 CF: 2412.000 MHz
 SPAN: 0.000 MHz
 RB: 10.000 MHz
 VB: 30.0 kHz
 Detector: ???
 Attn: 10 DB
 RL Offset: 0.0 DB
 Sweep Time: 5.4ms
 Ref Lvl: 87.0 DBUW

Comments
 HT20 mode
 On Time = 3.841ms

Cursor 1	1.0021	78.91	
Cursor 2	4.8433	0.00	

Delta Time (ms) 3.841
 Delta Amplitude 78.91

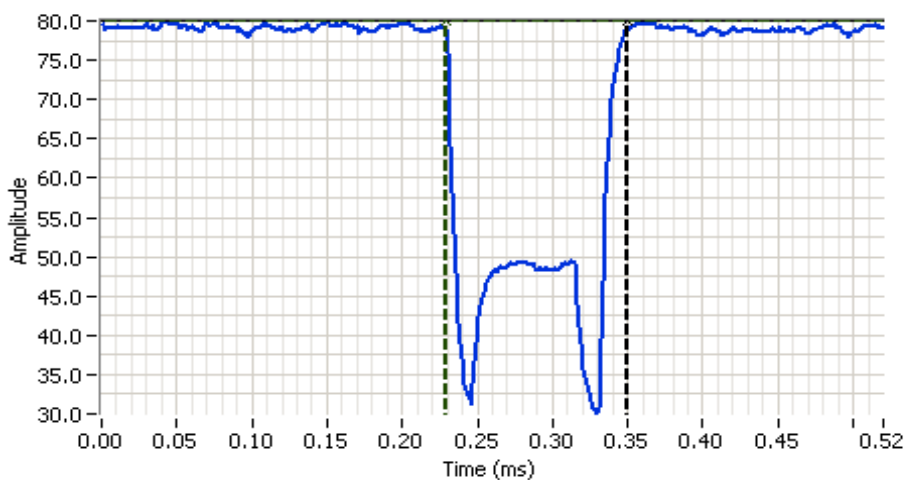

Analyzer Settings
 Rohde&Schwarz,ESI
 CF: 2412.000 MHz
 SPAN: 0.000 MHz
 RB: 10.000 MHz
 VB: 30.0 kHz
 Detector: POS
 Attn: 10 DB
 RL Offset: 0.0 DB
 Sweep Time: 0.5ms
 Ref Lvl: 87.0 DBUW

Comments
 HT20 Mode
 Off Time = 0.121ms

Cursor 1	0.2292	79.96	
Cursor 2	0.3498	79.96	

Delta Time (ms) 0.121
 Delta Amplitude 0.00



Client: Pace Americas, Inc.	Job Number: JD100298
Model: Wi-Fi Module 2.4 GHz	T-Log Number: T100355
Contact: Mark Rieger	Project Manager: Irene Radamacher
Standard: FCC Part 15.247	Project Coordinator: -
	Class: N/A

2.4GHz HT40 Plots

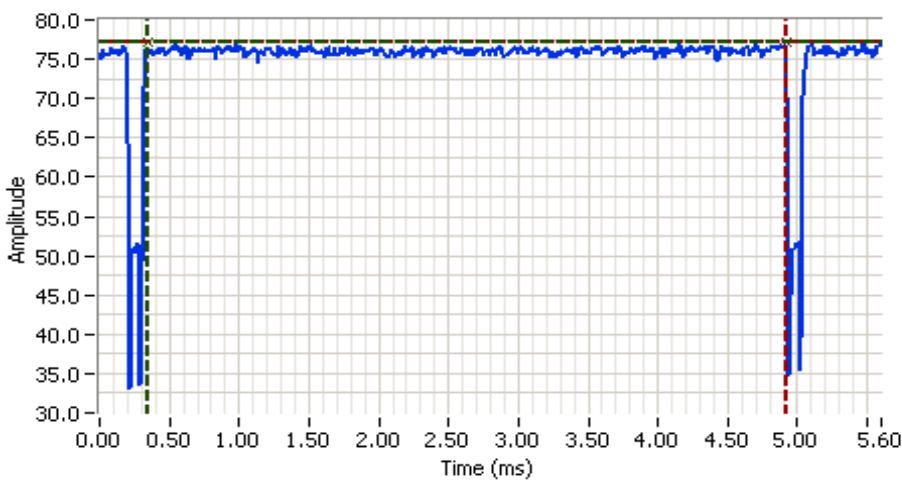

Analyzer Settings
 Rohde&Schwarz,ESI
 CF: 2424.800 MHz
 SPAN: 0.000 MHz
 RB: 10.000 MHz
 VB: 30.0 kHz
 Detector: ???
 Attn: 10 DB
 RL Offset: 0.0 DB
 Sweep Time: 5.6ms
 Ref Lvl: 87.0 DBUV

Comments
 HT40
 On Time = 4.575ms

Cursor 1 0.3464 77.16
 Cursor 2 4.9216 77.16

Delta Time (ms) 4.575
 Delta Amplitude 0.00

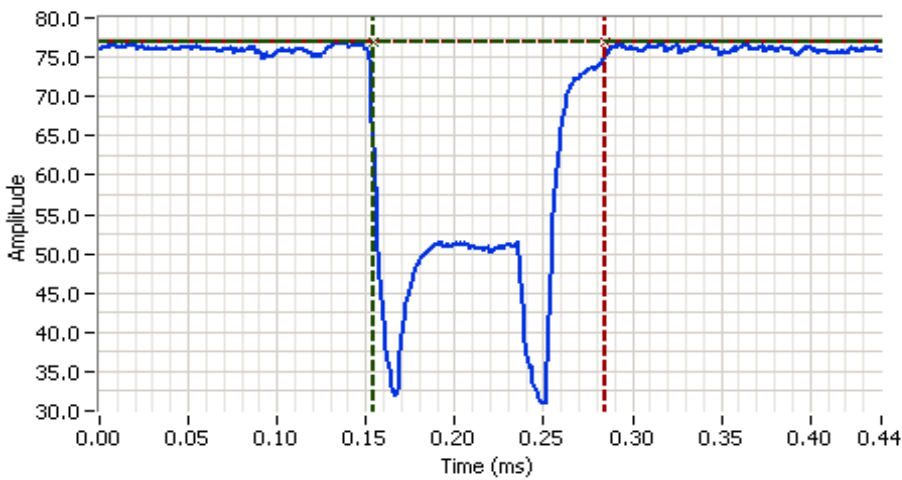

Analyzer Settings
 Rohde&Schwarz,ESI
 CF: 2424.800 MHz
 SPAN: 0.000 MHz
 RB: 10.000 MHz
 VB: 30.0 kHz
 Detector: POS
 Attn: 10 DB
 RL Offset: 0.0 DB
 Sweep Time: 0.4ms
 Ref Lvl: 87.0 DBUV

Comments
 HT40
 Off Time = 0.130ms

Cursor 1 0.1542 76.84
 Cursor 2 0.2846 76.84

Delta Time (ms) 0.130
 Delta Amplitude 0.00





EMC Test Data

Client: Pace Americas, Inc.	Job Number: JD100298
Model: Wi-Fi Module 2.4 GHz	T-Log Number: T100355
	Project Manager: Irene Radamacher
Contact: Mark Rieger	Project Coordinator: -
Standard: FCC Part 15.247	Class: N/A

RSS-247 and FCC 15.247 (DTS) Antenna Port Measurements MIMO and Smart Antenna Systems Power, PSD, Bandwidth and Spurious Emissions

Test Specific Details

Objective: The objective of this test session is to perform final qualification testing of the EUT with respect to the specification listed above.

Date of Test: 2/8-/2/10, 2016	Config. Used: 1
Test Engineer: Rafael Varelas & John Caizzi	Config Change: None
Test Location: FT Lab #4B	EUT Voltage: 120V/60Hz

General Test Configuration

The EUT was connected to the spectrum analyzer or power meter via a suitable attenuator. All measurements were made on a single chain.
All measurements have been corrected to allow for the external attenuators used.

Ambient Conditions:

Temperature: 21.8 °C
Rel. Humidity: 35 %

Summary of Results

Run #	Test Performed	Limit	Pass / Fail	Result / Margin
1	Output Power	15.247(b)	Pass	11b: 26.9dBm (-1.0dB) 11g: 27.5dBm (-.4dB) n20: 27.6dBm (-.3dB) n40: 21.2dBm (-6.7dB)
2	Power spectral Density (PSD)	15.247(d)	Pass	11b: 6.5 dBm/3kHz (-1.5dB) 11g: 1.7dBm/3kHz (-6.3dB) n20: 1.3dBm/3kHz (-6.7dB) n40: -6.0dBm/3kHz (-14.0dB)
3	Minimum 6dB Bandwidth	15.247(a)	Pass	11b: 8.5 MHz 11g: 15.4 MHz n20: 15.6 MHz n40: 35.2 MHz



EMC Test Data

Client: Pace Americas, Inc.	Job Number: JD100298
Model: Wi-Fi Module 2.4 GHz	T-Log Number: T100355
	Project Manager: Irene Radamacher
Contact: Mark Rieger	Project Coordinator: -
Standard: FCC Part 15.247	Class: N/A

3		99% Bandwidth	RSS GEN	Pass	11b: 13.0 MHz 11g: 20.9 MHz n20: 18.2 MHz n40: 36.7 MHz
4		Spurious emissions	15.247(b)	Pass	All emissions < -30 dBc

Modifications Made During Testing

No modifications were made to the EUT during testing

Deviations From The Standard

No deviations were made from the requirements of the standard.

Procedure Comments:

Measurements performed in accordance with FCC KDB 558074

Mode	Data Rate	Duty Cycle (x)	Constant DC?	T (ms)	Pwr Cor Factor*	Lin Volt Cor Factor**	Min VBW for FS (Hz)
11b	2 Mb/s	100%	Yes	10	0.0	0.0	10
11g	6 Mb/s	98.5%	Yes	2.157	0.0	0.0	10
n20	MCS 0	98.5%	Yes	2.018	0.0	0.0	10
n40	MCS 0	90.4%	Yes	1.249	0.4	0.9	801

Sample Notes

Sample S/N: PAV80000005

Driver:

Antenna Gain Information

Freq	Antenna Gain (dBi) / Chain				BF	MultiChain Legacy	CDD	Sectorized / Xpol	Dir G (PWR)	Dir G (PSD)
	1	2	3	4						
2412-2462	2.3	5.1	2.3		Yes	Yes	Yes, n modes only	No	8.1	8.1

For devices that support CDD modes

Min # of spatial streams: 3
Max # of spatial streams: 3



EMC Test Data

Client:	Pace Americas, Inc.	Job Number:	JD100298
Model:	Wi-Fi Module 2.4 GHz	T-Log Number:	T100355
		Project Manager:	Irene Radamacher
Contact:	Mark Rieger	Project Coordinator:	-
Standard:	FCC Part 15.247	Class:	N/A

Notes:	BF = beamforming mode supported, Multichain Legacy = 802.11 legacy data rates supported for multichain transmissions, CDD = Cyclic Delay Diversity (or Cyclic Shift Diversity) modes supported, Sectorized / Xpol = antennas are sectorized or cross polarized
Notes:	Dir G (PWR) = total gain (Gant + Array Gain) for power calculations; Dir G (PSD) = total gain for PSD calculations based on FCC KDB 662911. Depending on the modes supported, the Array Gain value for power could be different from the PSD value.
Notes:	Array gain for power/psd calculated per KDB 662911 D01, v01r02.



EMC Test Data

Client: Pace Americas, Inc.	Job Number: JD100298
Model: Wi-Fi Module 2.4 GHz	T-Log Number: T100355
	Project Manager: Irene Radamacher
Contact: Mark Rieger	Project Coordinator: -
Standard: FCC Part 15.247	Class: N/A

Run #1: Output Power

Operating Mode: b
Directional Gain (dBi): 8.1

Max EIRP (mW): 3192.44

Frequency (MHz)	Chain	Software Setting	Power ¹		Total		Max Power (W)	Limit dBm	Result	Power (dBm) ³
			dBm	mW	mW	dBm				
2412	1	23.5	21.8	151.4	483.4	26.8	0.494	27.9	Pass	
	3		22.3	169.8						
	4									
	2		22.1	162.2						
2437	1	23.5	22.1	162.2	494.5	26.9		27.9	Pass	
	3		22.4	173.8						
	4									
	2		22.0	158.5						
2462	1	23.5	21.8	151.4	479.7	26.8		27.9	Pass	
	3		22.3	169.8						
	4									
	2		22.0	158.5						

Note 1: Duty Cycle ≥ 98%. Output power measured using a spectrum analyzer (see plots below) with RBW= 1-5% of OBW and ≤ 1 MHz, VB≥3* RBW, Span ≥ 1.5 of OBW, auto sweep time, RMS detector, power averaging on, and power integration over the OBW, trace average 100 traces (option AVGSA-1 in ANSI C63.10). Spurious limit becomes -30dBc.

Client: Pace Americas, Inc.	Job Number: JD100298
Model: Wi-Fi Module 2.4 GHz	T-Log Number: T100355
	Project Manager: Irene Radmacher
Contact: Mark Rieger	Project Coordinator: -
Standard: FCC Part 15.247	Class: N/A

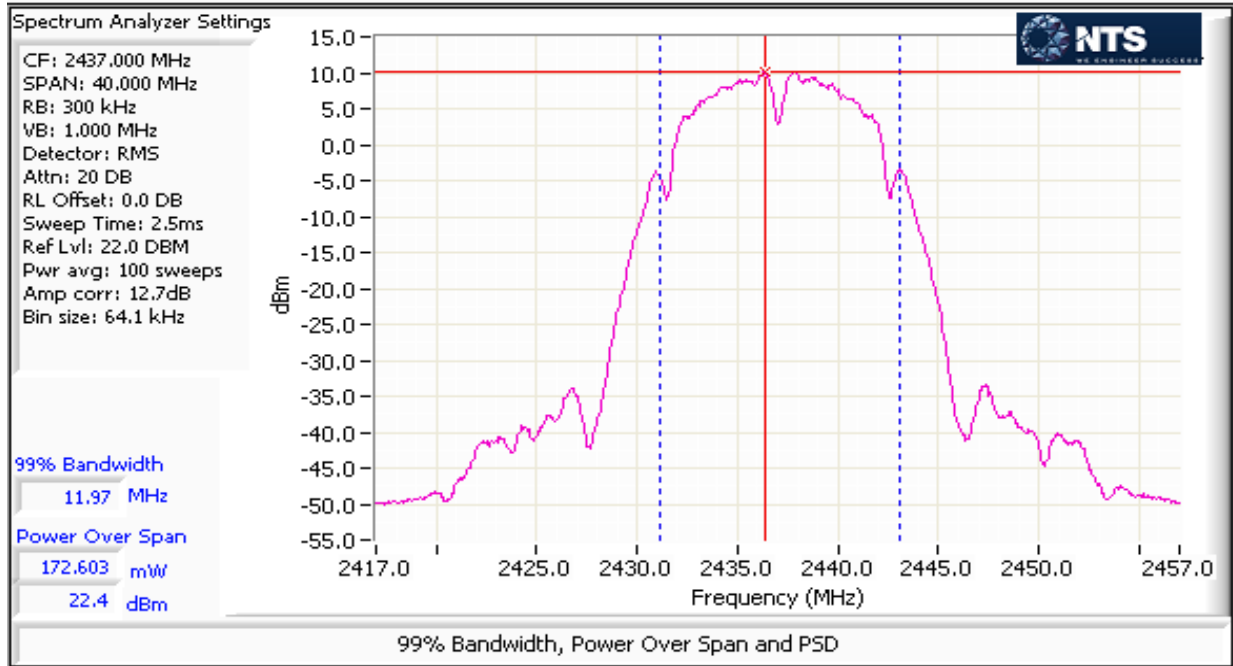



EMC Test Data

Client: Pace Americas, Inc.	Job Number: JD100298
Model: Wi-Fi Module 2.4 GHz	T-Log Number: T100355
	Project Manager: Irene Radamacher
Contact: Mark Rieger	Project Coordinator: -
Standard: FCC Part 15.247	Class: N/A

Operating Mode: g
Directional Gain (dBi): 8.1

Max EIRP (mW): 3607.4308

Frequency (MHz)	Chain	Software Setting	Power ¹		Total		Max Power (W)	Limit dBm	Result	Power (dBm) ³
			dBm	mW	mW	dBm				
2412	1	20.5	18.2	66.1	216.1	23.3	0.559	27.9	Pass	
	3		18.8	75.9						
	4									
	2		18.7	74.1						
2437	1	24	22.6	182.0	558.7	27.5		27.9	Pass	
	3		22.8	190.5						
	4									
	2		22.7	186.2						
2462	1	19.5	17.4	55.0	171.4	22.3		27.9	Pass	
	3		17.8	60.3						
	4									
	2		17.5	56.2						

Note 1: Duty Cycle ≥ 98%. Output power measured using a spectrum analyzer (see plots below) with RBW= 1-5% of OBW and ≤ 1 MHz, VB≥3* RBW, Span ≥ 1.5 of OBW, auto sweep time, RMS detector, power averaging on, and power integration over the OBW, trace average 100 traces (option AVGSA-1 in ANSI C63.10). Spurious limit becomes -30dBc.

Client: Pace Americas, Inc.	Job Number: JD100298
Model: Wi-Fi Module 2.4 GHz	T-Log Number: T100355
	Project Manager: Irene Radmacher
Contact: Mark Rieger	Project Coordinator: -
Standard: FCC Part 15.247	Class: N/A

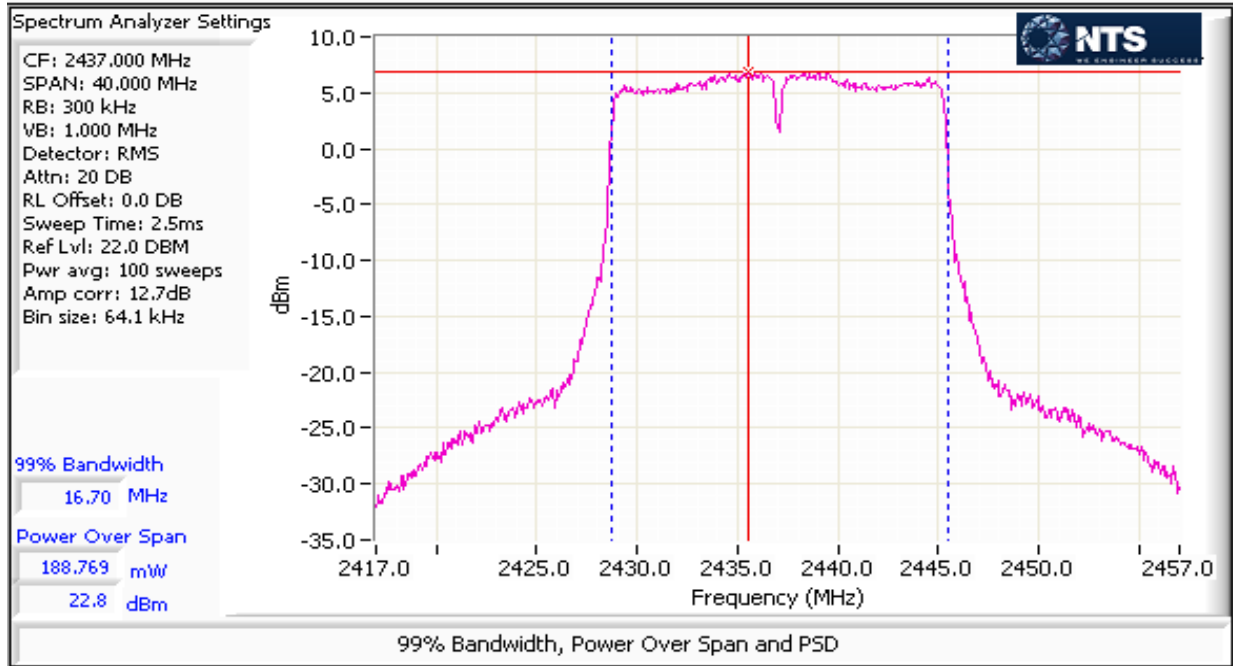



EMC Test Data

Client: Pace Americas, Inc.	Job Number: JD100298
Model: Wi-Fi Module 2.4 GHz	T-Log Number: T100355
	Project Manager: Irene Radamacher
Contact: Mark Rieger	Project Coordinator: -
Standard: FCC Part 15.247	Class: N/A

Operating Mode: n20
 Directional Gain (dBi): 8.1

Max EIRP (mW): 3722.0725

Frequency (MHz)	Chain	Software Setting	Power ¹		Total		Max Power (W)	Limit dBm	Result	Power (dBm) ³
			dBm	mW	mW	dBm				
2412	1	19.5	18.0	63.1	198.3	23.0	0.576	27.9	Pass	
	3		18.4	69.2						
	4									
	2		18.2	66.1						
2437	1	24.5	22.6	182.0	576.5	27.6		27.9	Pass	
	3		23.0	199.5						
	4									
	2		22.9	195.0						
2462	1	17.5	15.8	38.0	113.4	20.5		27.9	Pass	
	3		16.1	40.7						
	4									
	2		15.4	34.7						

Note 1: Duty Cycle ≥ 98%. Output power measured using a spectrum analyzer (see plots below) with RBW= 1-5% of OBW and ≤ 1 MHz, VB≥3* RBW, Span ≥ 1.5 of OBW, auto sweep time, RMS detector, power averaging on, and power integration over the OBW, trace average 100 traces (option AVGSA-1 in ANSI C63.10). Spurious limit becomes -30dBc.

Client: Pace Americas, Inc.	Job Number: JD100298
Model: Wi-Fi Module 2.4 GHz	T-Log Number: T100355
	Project Manager: Irene Radmacher
Contact: Mark Rieger	Project Coordinator: -
Standard: FCC Part 15.247	Class: N/A

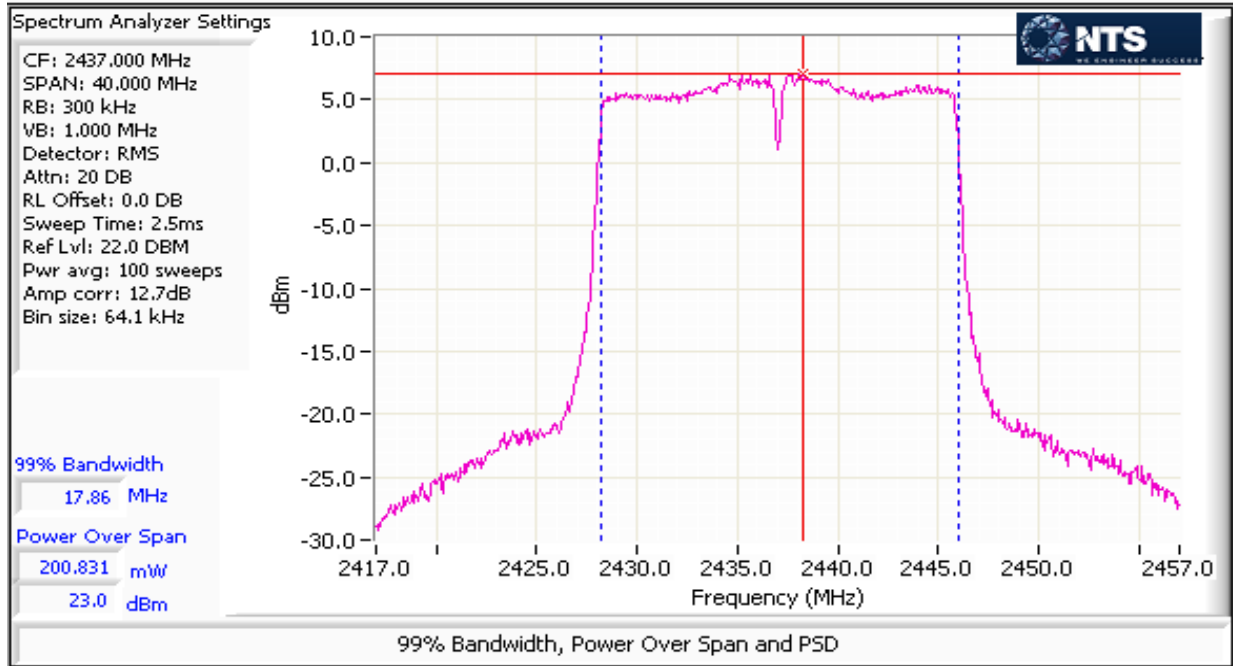



EMC Test Data

Client: Pace Americas, Inc.	Job Number: JD100298
Model: Wi-Fi Module 2.4 GHz	T-Log Number: T100355
	Project Manager: Irene Radamacher
Contact: Mark Rieger	Project Coordinator: -
Standard: FCC Part 15.247	Class: N/A

Operating Mode: n40
Directional Gain (dBi): 8.1

Max EIRP (mW): 845.95978

Frequency (MHz)	Chain	Software Setting	Power ¹		Total		Max Power (W)	Limit dBm	Result	Power (dBm) ³	
			dBm	mW	mW	dBm					
2422	1	17.5	16.1	40.7	122.2	20.9	0.131	27.9	Pass		
	3		16.2	41.7							
	4										
	2		16.0	39.8							
2437	1	17.5	16.5	44.7	131.0	21.2		0.131	27.9	Pass	
	3		16.5	44.7							
	4										
	2		16.2	41.7							
2452	1	14.5	13.1	20.4	67.9	18.3			0.131	27.9	Pass
	3		13.9	24.5							
	4										
	2		13.6	22.9							

- Note 1: Constant Duty Cycle < 98%. Output power measured using a spectrum analyzer (see plots below) with RBW= 1-5% of OBW and ≤ 1 MHz, VB≥3* RBW, Span ≥ 1.5 of OBW, RMS detector, auto sweep time, power averaging on, and power integration over the OBW, trace average 100 traces (option AVGSA-2 in ANSI C63.10). Measurement corrected by Pwr Cor Factor. Spurious limit becomes -30dBc.
- Note 2: Power setting - the software power setting used during testing, included for reference only.
- Note 3: Power measured using average power meter (non-gated) and is included for reference only.

Client: Pace Americas, Inc.	Job Number: JD100298
Model: Wi-Fi Module 2.4 GHz	T-Log Number: T100355
	Project Manager: Irene Radmacher
Contact: Mark Rieger	Project Coordinator: -
Standard: FCC Part 15.247	Class: N/A

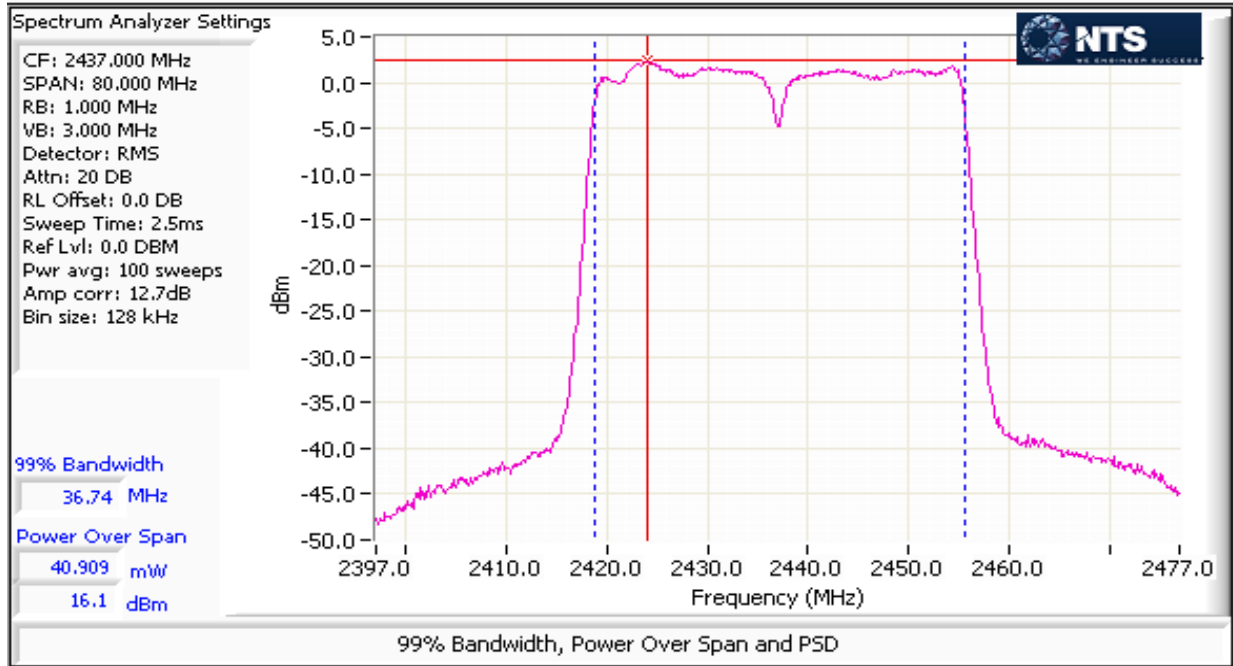



EMC Test Data

Client: Pace Americas, Inc.	Job Number: JD100298
Model: Wi-Fi Module 2.4 GHz	T-Log Number: T100355
Contact: Mark Rieger	Project Manager: Irene Radamacher
Standard: FCC Part 15.247	Project Coordinator: -
	Class: N/A

Run #2: Power spectral Density

Mode: 11b

Power Setting	Frequency (MHz)	PSD (dBm/3kHz) ^{Note 1}				Total	Limit dBm/3kHz	Result
		Chain 1	Chain 2	Chain 3	Chain 4			
25.5	2412	1.8	1.4	1.4		6.3	8.0	Pass
26.0	2437	1.8	1.6	1.9		6.5	8.0	Pass
27.0	2437	2.1	1.9	2.2		6.8	8.0	Pass
25.5	2462	1.2	1.1	1.4		6.0	8.0	Pass

Mode: 11g

Power Setting	Frequency (MHz)	PSD (dBm/3kHz) ^{Note 1}				Total	Limit dBm/3kHz	Result
		Chain 1	Chain 2	Chain 3	Chain 4			
20.5	2412	-6.8	-7.0	-7.2		-2.2	8.0	Pass
24.5	2437	-3.2	-3.3	-2.8		1.7	8.0	Pass
27.0	2437	0.3	-0.3	-0.3		4.7	8.0	Pass
19.5	2462	-8.1	-7.9	-8.1		-3.3	8.0	Pass

Mode: n20

Power Setting	Frequency (MHz)	PSD (dBm/3kHz) ^{Note 1}				Total	Limit dBm/3kHz	Result
		Chain 1	Chain 2	Chain 3	Chain 4			
20	2412	-6.3	-6.4	-6.1		-1.5	8.0	Pass
24.5	2437	-3.8	-3.8	-3.0		1.3	8.0	Pass
17.5	2462	-9.7	-10.1	-9.6		-5.0	8.0	Pass

Mode: n40

Power Setting	Frequency (MHz)	PSD (dBm/3kHz) ^{Note 1}				Total	Limit dBm/3kHz	Result
		Chain 1	Chain 2	Chain 3	Chain 4			
17.5	2422	-10.4	-11.2	-10.8		-6.0	8.0	Pass
17.5	2437	-11.4	-11.2	-11.1		-6.5	8.0	Pass
14.5	2452	-13.9	-14.1	-13.2		-8.9	8.0	Pass

Note 1: Test performed per method PKSPD, in KDB 558074. Power spectral density measured using: $3\text{kHz} \leq \text{RBW} \leq 100\text{kHz}$, $\text{VBW}=3*\text{RBW}$, peak detector, span = $1.5*\text{DTS BW}$, auto sweep time, max hold.

Client: Pace Americas, Inc.	Job Number: JD100298
Model: Wi-Fi Module 2.4 GHz	T-Log Number: T100355
Contact: Mark Rieger	Project Manager: Irene Radamacher
Standard: FCC Part 15.247	Project Coordinator: -
	Class: N/A

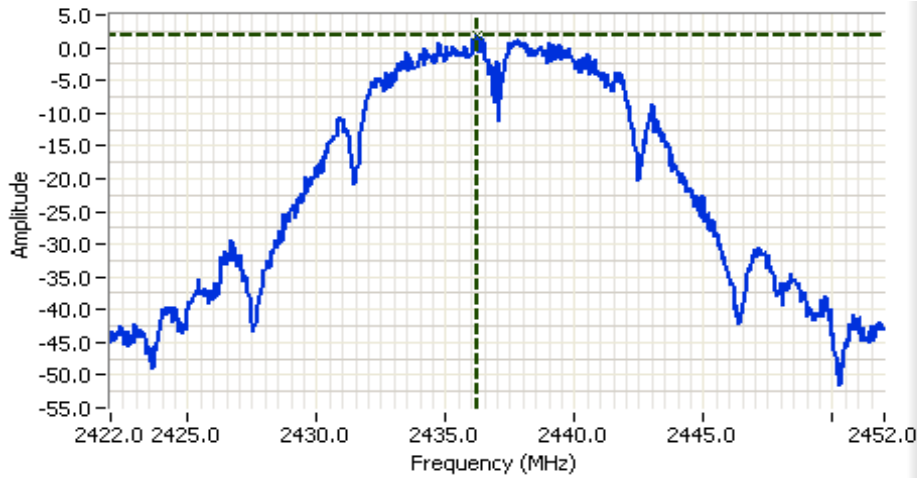

Analyzer Settings

Rohde&Schwarz,FSQ
 CF: 2437.000 MHz
 SPAN: 30.000 MHz
 RB: 3.00 kHz
 VB: 10.0 kHz
 Detector: POS
 Attn: 35 DB
 RL Offset: 12.7 DB
 Sweep Time: 3.4s
 Ref Lvl: 32.7 DBM

Comments

PSD: 1.9 dBm/3kHz
 802.11b, Chain 3

Cursor 1 2436.2308 1.9

0.0000 0.0

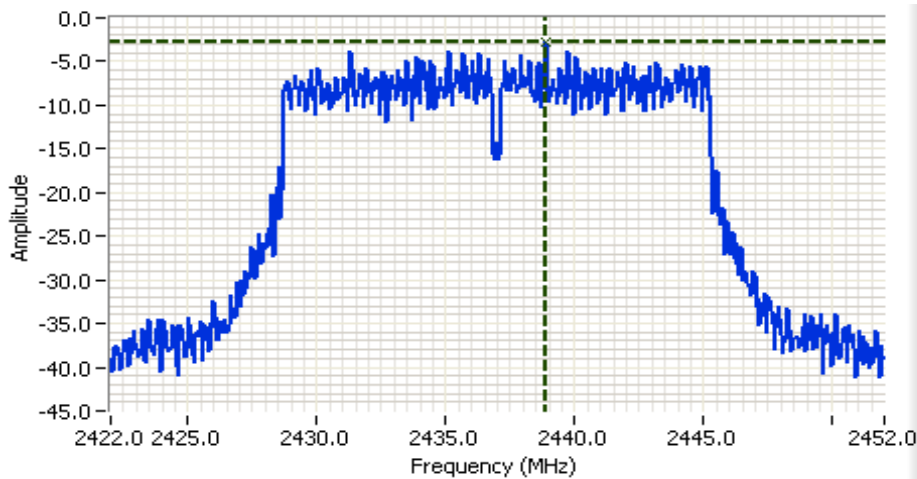

Analyzer Settings

Rohde&Schwarz,FSQ
 CF: 2437.000 MHz
 SPAN: 30.000 MHz
 RB: 3.00 kHz
 VB: 10.0 kHz
 Detector: POS
 Attn: 35 DB
 RL Offset: 12.7 DB
 Sweep Time: 3.4s
 Ref Lvl: 32.7 DBM

Comments

PSD: -2.8 dBm/3kHz
 802.11g, Chain 3

Cursor 1 2438.8750 -2.8

0.0000 0.0



Client: Pace Americas, Inc.	Job Number: JD100298
Model: Wi-Fi Module 2.4 GHz	T-Log Number: T100355
Contact: Mark Rieger	Project Manager: Irene Radmacher
Standard: FCC Part 15.247	Project Coordinator: -
	Class: N/A

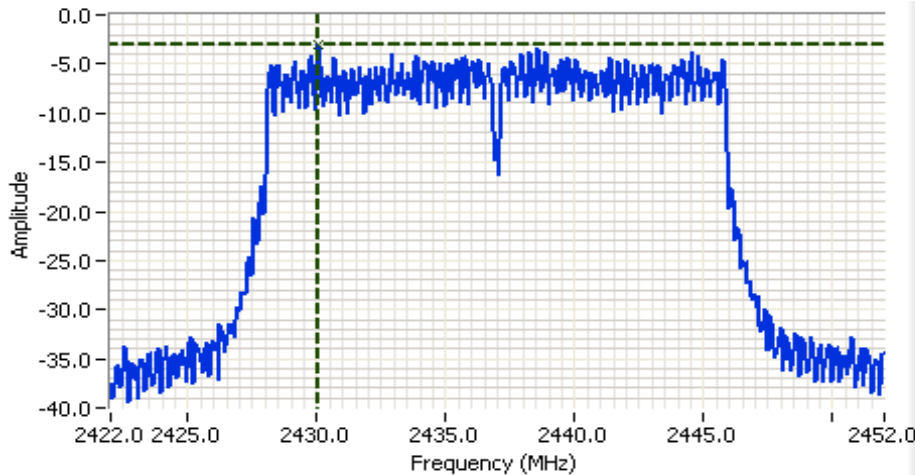

Analyzer Settings

Rohde&Schwarz,FSQ
 CF: 2437.000 MHz
 SPAN: 30.000 MHz
 RB: 3.00 kHz
 VB: 10.0 kHz
 Detector: POS
 Attn: 35 DB
 RL Offset: 12.7 DB
 Sweep Time: 3.4s
 Ref Lvl: 32.7 DBM

Comments

PSD: -3.0 dBm/3kHz
 802.11n20, Chain 3

Cursor 1 2430.0769 -3.0

0.0000 0.0

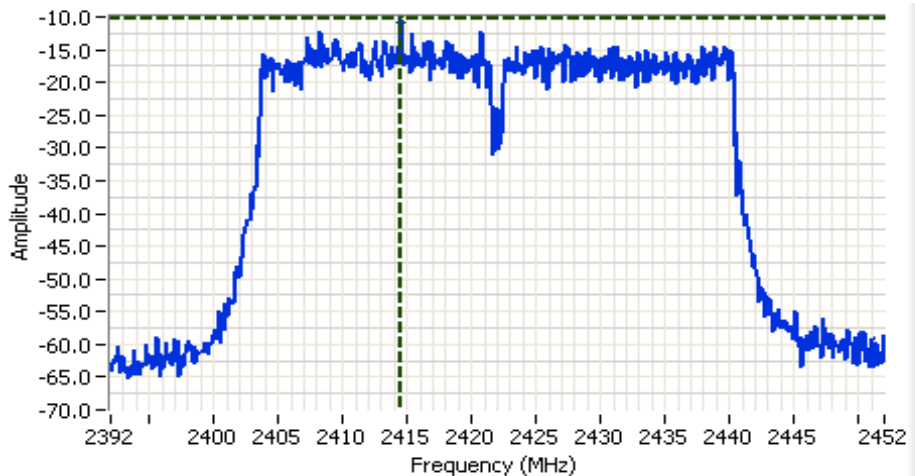

Analyzer Settings

Rohde&Schwarz,FSQ
 CF: 2422.000 MHz
 SPAN: 60.000 MHz
 RB: 3.00 kHz
 VB: 10.0 kHz
 Detector: POS
 Attn: 20 DB
 RL Offset: 12.7 DB
 Sweep Time: 6.8s
 Ref Lvl: 19.7 DBM

Comments

PSD: -10.4 dBm/3kHz
 802.11n40, Chain 1

Cursor 1 2414.5000 -10.4

0.0000 0.0





EMC Test Data

Client: Pace Americas, Inc.	Job Number: JD100298
Model: Wi-Fi Module 2.4 GHz	T-Log Number: T100355
	Project Manager: Irene Radamacher
Contact: Mark Rieger	Project Coordinator: -
Standard: FCC Part 15.247	Class: N/A

Run #3: Signal Bandwidth

Mode: 11b

Power Setting	Frequency (MHz)	Bandwidth (MHz)		RBW Setting (kHz)	
		6dB	99%	6dB	99%
27	2412	8.5	12.9	100	300
27	2437	9.0	12.8	100	300
27	2462	8.6	13.0	100	300

Mode: 11g

Power Setting	Frequency (MHz)	Bandwidth (MHz)		RBW Setting (kHz)	
		6dB	99%	6dB	99%
27	2412	15.4	19.9	100	300
27	2437	15.7	19.5	100	300
27	2462	15.7	20.9	100	300

Mode: n20

Power Setting	Frequency (MHz)	Bandwidth (MHz)		RBW Setting (kHz)	
		6dB	99%	6dB	99%
24.5	2412	15.7	18.1	100	300
24.5	2437	16.9	18.2	100	300
24.5	2462	15.6	18.1	100	300

Mode: n40

Power Setting	Frequency (MHz)	Bandwidth (MHz)		RBW Setting (kHz)	
		6dB	99%	6dB	99%
24.5	2422	35.2	36.6	100	500
24.5	2437	35.8	36.7	100	500
24.5	2462	35.8	36.6	100	500

Note 1: DTS BW: RBW=100kHz, VBW ≥ 3*RBW, peak detector, max hold, auto sweep time, Span 2-5 times measured BW.
 99% BW: RBW=1-5% of 99%BW, VBW ≥ 3*RBW, peak detector, max hold, auto sweep time. Span 1.5-5 times OBW.

Note 2: Measurements performed on chain 3

Client: Pace Americas, Inc.	Job Number: JD100298
Model: Wi-Fi Module 2.4 GHz	T-Log Number: T100355
Contact: Mark Rieger	Project Manager: Irene Radmacher
Standard: FCC Part 15.247	Project Coordinator: -
	Class: N/A

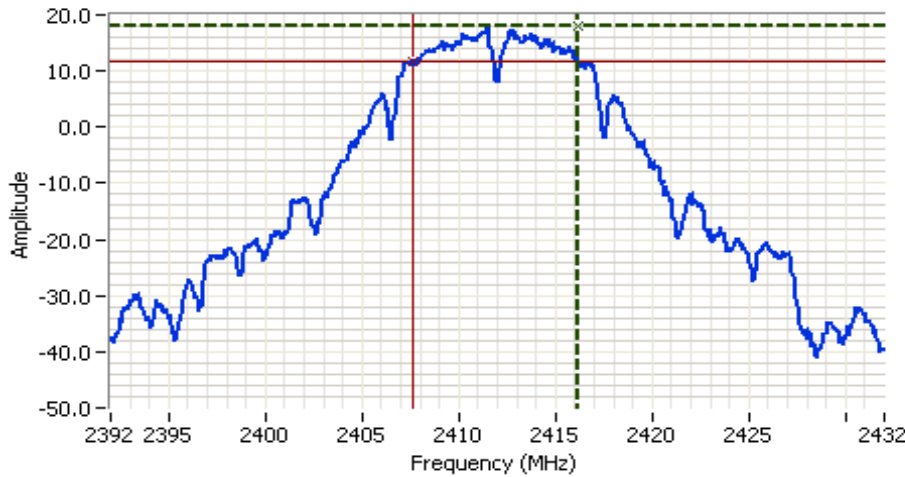

Analyzer Settings
 Rohde&Schwarz,FSQ
 CF: 2412.000 MHz
 SPAN: 40.000 MHz
 RB: 100 kHz
 VB: 300 kHz
 Detector: POS
 Attn: 20 DB
 RL Offset: 12.7 DB
 Sweep Time: 15.0ms
 Ref Lvl: 19.7 DBM

Comments
 6dB BW: 8.526 MHz
 802.11b

Cursor 1 2416.1667 17.9

Cursor 2 2407.6410 11.9

Delta Freq. 8.526

Delta Amplitude 6.0

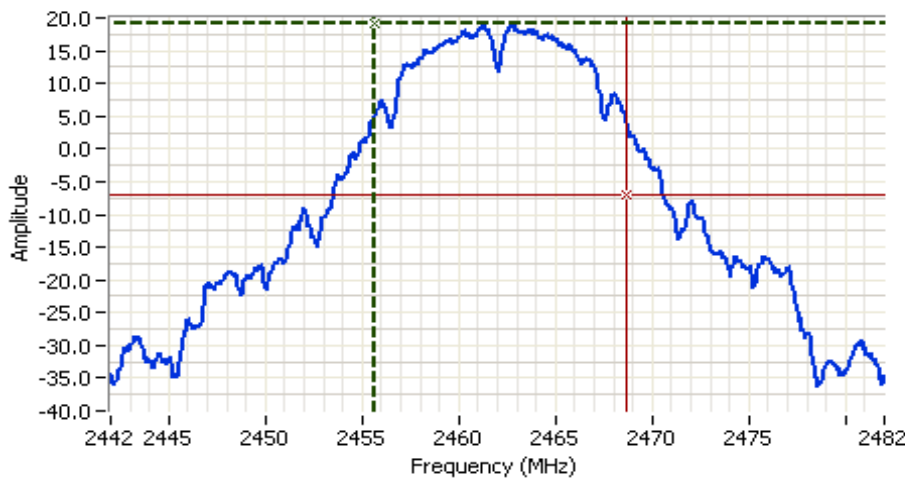

Analyzer Settings
 Rohde&Schwarz,FSQ
 CF: 2462.000 MHz
 SPAN: 40.000 MHz
 RB: 300 kHz
 VB: 1.000 MHz
 Detector: POS
 Attn: 20 DB
 RL Offset: 12.7 DB
 Sweep Time: 2.5ms
 Ref Lvl: 19.7 DBM

Comments
 99% BW: 12.992 MHz
 802.11b

Cursor 1 2455.6320 19.0

Cursor 2 2468.6240 -7.0

Delta Freq. 12.992

Delta Amplitude 26.0



Client: Pace Americas, Inc.	Job Number: JD100298
Model: Wi-Fi Module 2.4 GHz	T-Log Number: T100355
Contact: Mark Rieger	Project Manager: Irene Radamacher
Standard: FCC Part 15.247	Project Coordinator: -
	Class: N/A

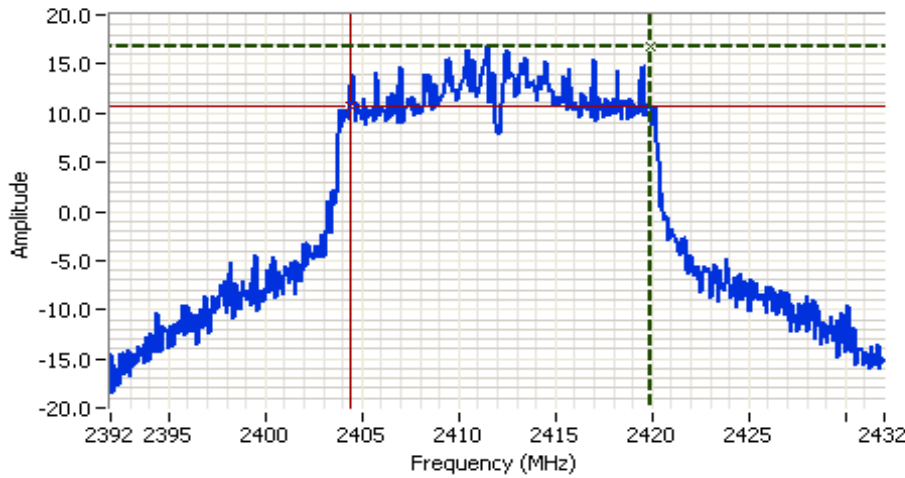

Analyzer Settings
 Rohde&Schwarz,FSQ
 CF: 2412.000 MHz
 SPAN: 40.000 MHz
 RB: 100 kHz
 VB: 300 kHz
 Detector: POS
 Attn: 20 DB
 RL Offset: 12.7 DB
 Sweep Time: 15.0ms
 Ref Lvl: 19.7 DBM

Comments
 6dB BW: 15.449 MHz
 802.11g

Cursor 1 2419.8846 16.8 

Cursor 2 2404.4359 10.8 

Delta Freq. 15.449

Delta Amplitude 6.0

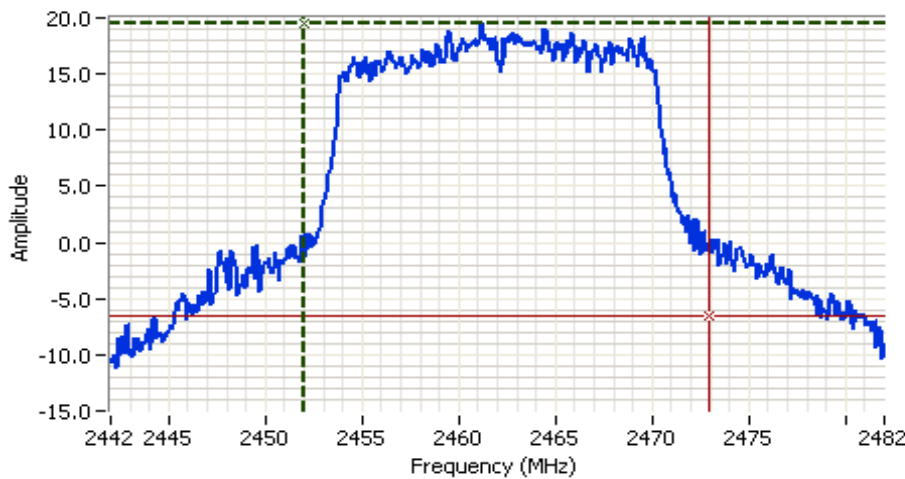

Analyzer Settings
 Rohde&Schwarz,FSQ
 CF: 2462.000 MHz
 SPAN: 40.000 MHz
 RB: 300 kHz
 VB: 1.000 MHz
 Detector: POS
 Attn: 20 DB
 RL Offset: 12.7 DB
 Sweep Time: 2.5ms
 Ref Lvl: 19.7 DBM

Comments
 99% BW: 20.928 MHz
 802.11g

Cursor 1 2452.0480 19.5 

Cursor 2 2472.9760 -6.5 

Delta Freq. 20.928

Delta Amplitude 26.0



Client: Pace Americas, Inc.	Job Number: JD100298
Model: Wi-Fi Module 2.4 GHz	T-Log Number: T100355
Contact: Mark Rieger	Project Manager: Irene Radamacher
Standard: FCC Part 15.247	Project Coordinator: -
	Class: N/A

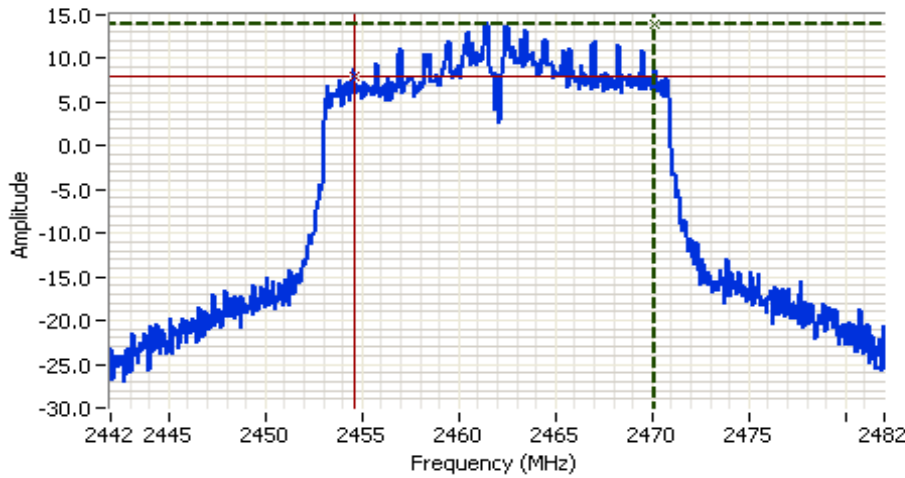

Analyzer Settings
 Rohde&Schwarz,FSQ
 CF: 2462.000 MHz
 SPAN: 40.000 MHz
 RB: 100 kHz
 VB: 300 kHz
 Detector: POS
 Attn: 20 DB
 RL Offset: 12.7 DB
 Sweep Time: 15.0ms
 Ref Lvl: 19.7 DBM

Comments
 6dB BW: 15.577 MHz
 802.11n20

Cursor 1 2470.1410 14.0

Cursor 2 2454.5641 8.0

Delta Freq. 15.577

Delta Amplitude 6.0

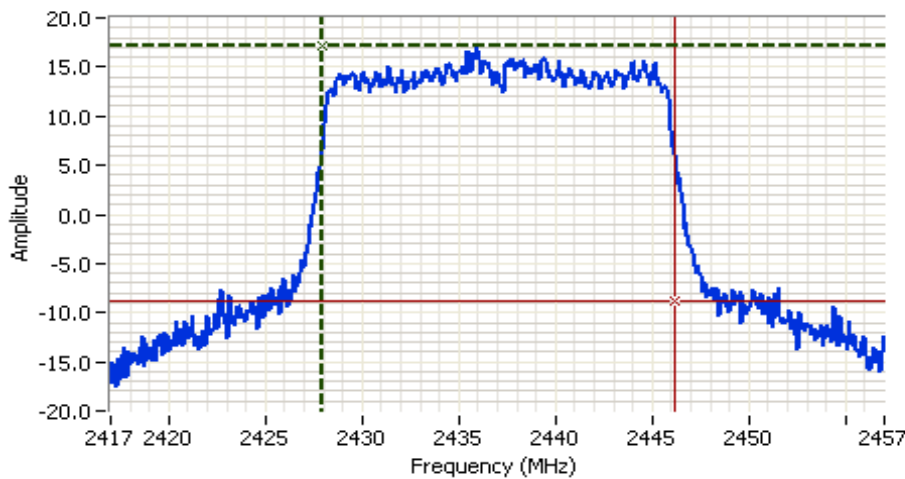

Analyzer Settings
 Rohde&Schwarz,FSQ
 CF: 2437.000 MHz
 SPAN: 40.000 MHz
 RB: 300 kHz
 VB: 1.000 MHz
 Detector: POS
 Attn: 20 DB
 RL Offset: 12.7 DB
 Sweep Time: 2.5ms
 Ref Lvl: 19.7 DBM

Comments
 99% BW: 18.240 MHz
 802.11n20

Cursor 1 2427.9440 17.1

Cursor 2 2446.1840 -8.9

Delta Freq. 18.240

Delta Amplitude 26.0



Client: Pace Americas, Inc.	Job Number: JD100298
Model: Wi-Fi Module 2.4 GHz	T-Log Number: T100355
Contact: Mark Rieger	Project Manager: Irene Radmacher
Standard: FCC Part 15.247	Project Coordinator: -
	Class: N/A

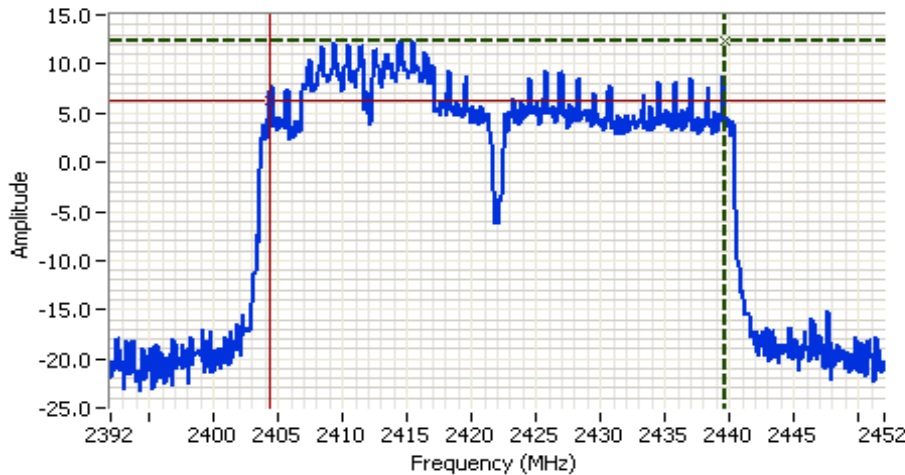

Analyzer Settings
 Rohde&Schwarz,FSQ
 CF: 2422.000 MHz
 SPAN: 60.000 MHz
 RB: 100 kHz
 VB: 300 kHz
 Detector: POS
 Attn: 20 DB
 RL Offset: 12.7 DB
 Sweep Time: 10.0ms
 Ref Lvl: 19.7 DBM

Comments
 6dB BW: 35.192 MHz
 802.11n40

Cursor 1 2439.5962 12.4
 Cursor 2 2404.4038 6.4

Delta Freq. 35.192
 Delta Amplitude 6.0



Analyzer Settings
 Rohde&Schwarz,FSQ
 CF: 2437.000 MHz
 SPAN: 60.000 MHz
 RB: 500 kHz
 VB: 2.000 MHz
 Detector: POS
 Attn: 20 DB
 RL Offset: 12.7 DB
 Sweep Time: 2.5ms
 Ref Lvl: 19.7 DBM

Comments
 99% BW: 36.672 MHz
 802.11n40

Cursor 1 2418.8080 17.8
 Cursor 2 2455.4800 -8.2

Delta Freq. 36.672
 Delta Amplitude 26.0



Client: Pace Americas, Inc.	Job Number: JD100298
Model: Wi-Fi Module 2.4 GHz	T-Log Number: T100355
	Project Manager: Irene Radamacher
Contact: Mark Rieger	Project Coordinator: -
Standard: FCC Part 15.247	Class: N/A

Run #4a: Out of Band Spurious Emissions

Power Setting Per Chain				Mode	Frequency (MHz)	Limit	Result
#1	#2	#3	#4				
26	26	26		b	2412	-30dBc	Pass
27	27	27		b	2437	-30dBc	Pass
26	26	26		b	2462	-30dBc	Pass
23	23	23		g	2412	-30dBc	Pass
27	27	27		g	2437	-30dBc	Pass
27	27	27		g	2462	-30dBc	Pass
20	20	20		n20	2412	-30dBc	Pass
24.5	24.5	24.5		n20	2437	-30dBc	Pass
24.5	24.5	24.5		n20	2462	-30dBc	Pass
17.5	17.5	17.5		n40	2422	-30dBc	Pass
17.5	17.5	17.5		n40	2437	-30dBc	Pass
17.5	17.5	17.5		n40	2452	-30dBc	Pass

Note 1: Measured on each chain individually. Power setting for all channels the same as for channel 6.

Plots for low channel, 802.11b mode

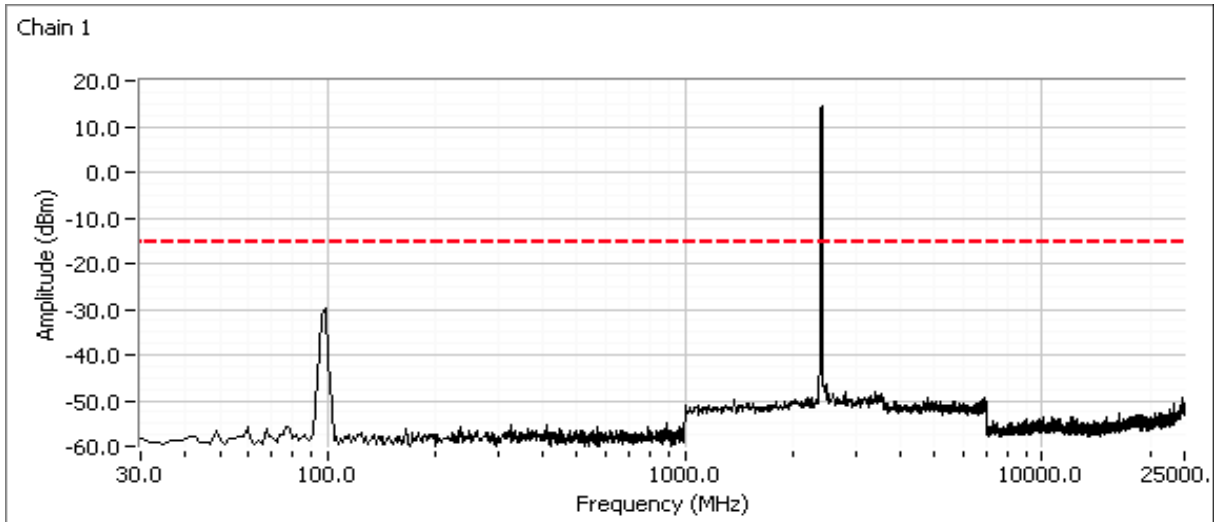

Client: Pace Americas, Inc.	Job Number: JD100298
Model: Wi-Fi Module 2.4 GHz	T-Log Number: T100355
Contact: Mark Rieger	Project Manager: Irene Radmacher
Standard: FCC Part 15.247	Project Coordinator: -
	Class: N/A

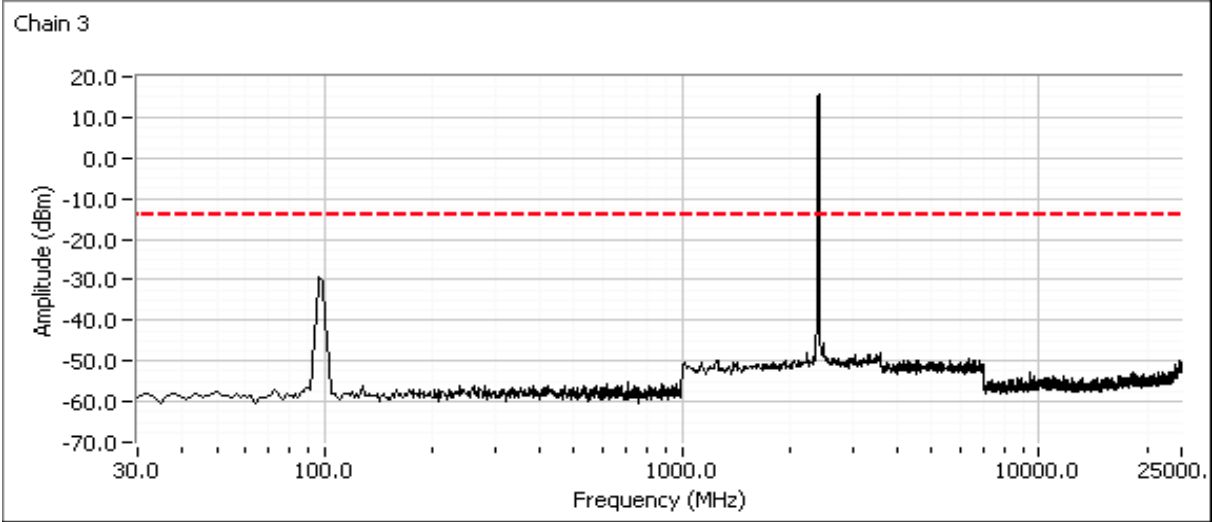
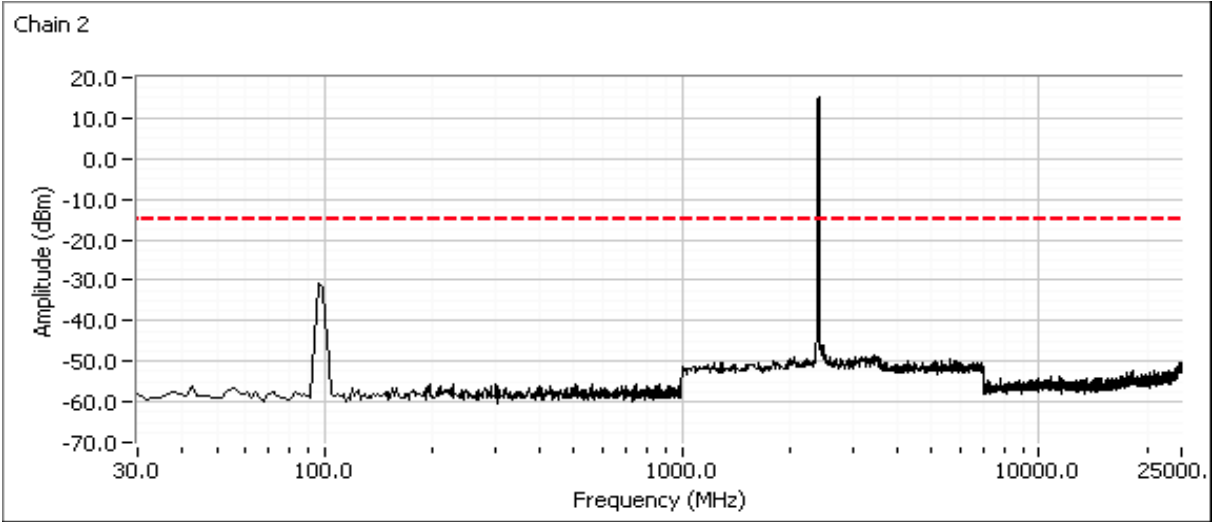

Client: Pace Americas, Inc.	Job Number: JD100298
Model: Wi-Fi Module 2.4 GHz	T-Log Number: T100355
	Project Manager: Irene Radamacher
Contact: Mark Rieger	Project Coordinator: -
Standard: FCC Part 15.247	Class: N/A

Additional plot showing compliance with -30dBc limit from 2390 MHz to 2400 MHz. Radiated measurements used to show compliance with the limits in the restricted band below 2390 MHz.

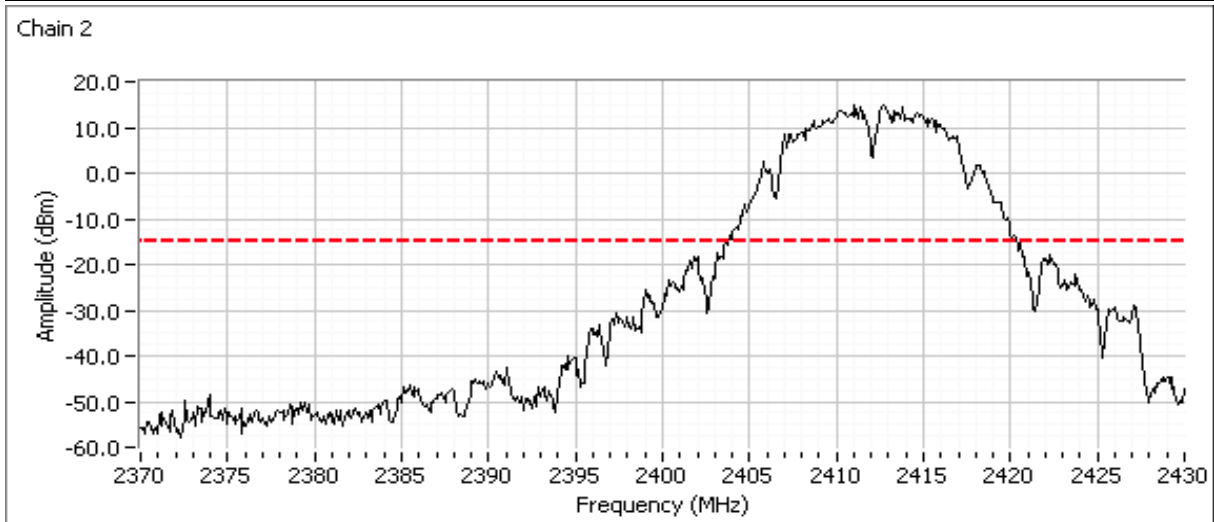
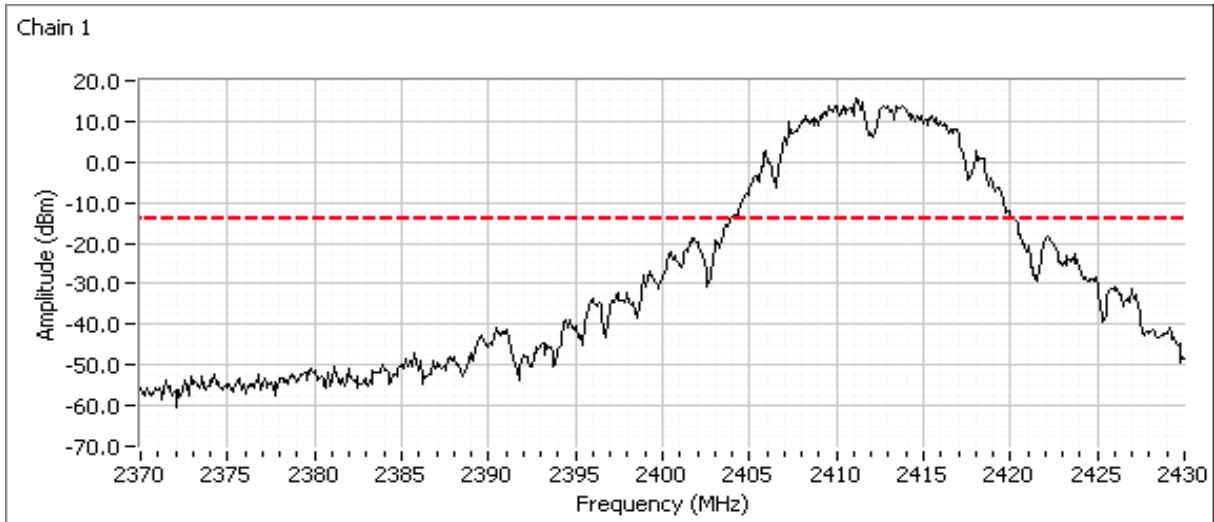

Client: Pace Americas, Inc.	Job Number: JD100298
Model: Wi-Fi Module 2.4 GHz	T-Log Number: T100355
	Project Manager: Irene Radmacher
Contact: Mark Rieger	Project Coordinator: -
Standard: FCC Part 15.247	Class: N/A

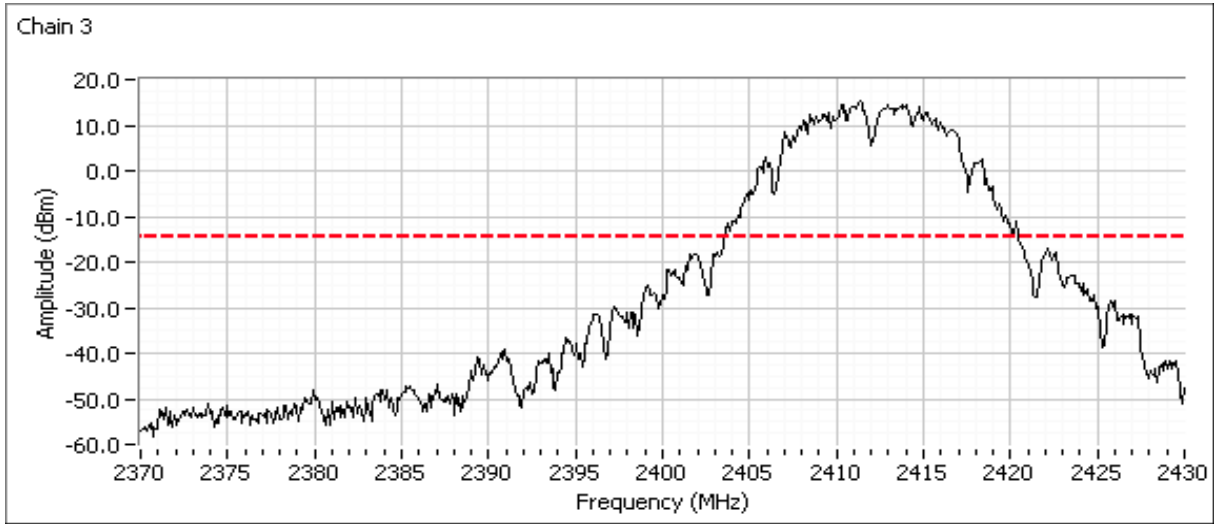

Plots for center channel, 802.11b Mode

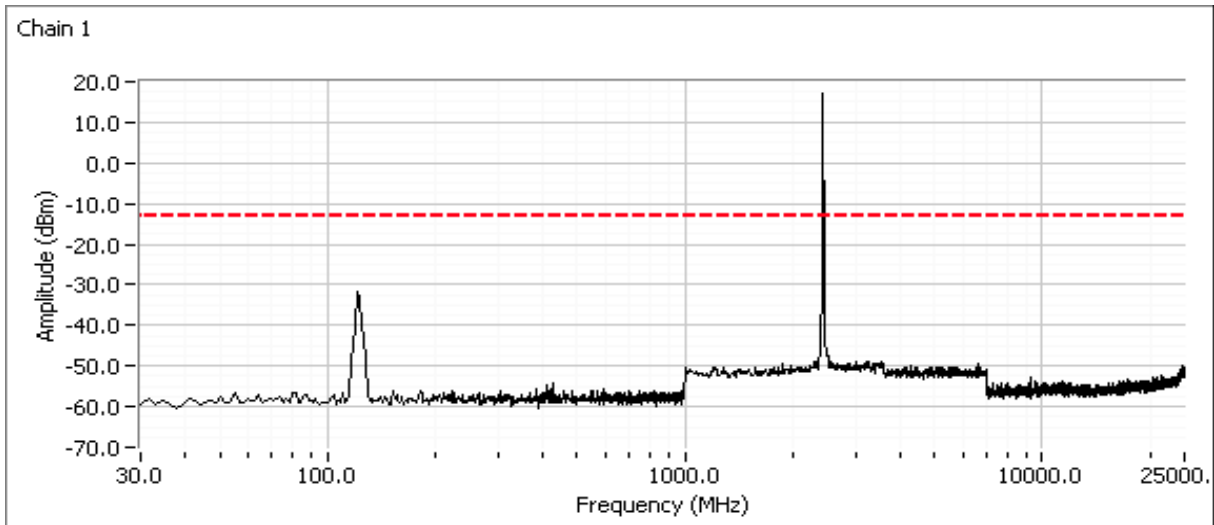

Client: Pace Americas, Inc.	Job Number: JD100298
Model: Wi-Fi Module 2.4 GHz	T-Log Number: T100355
	Project Manager: Irene Radmacher
Contact: Mark Rieger	Project Coordinator: -
Standard: FCC Part 15.247	Class: N/A

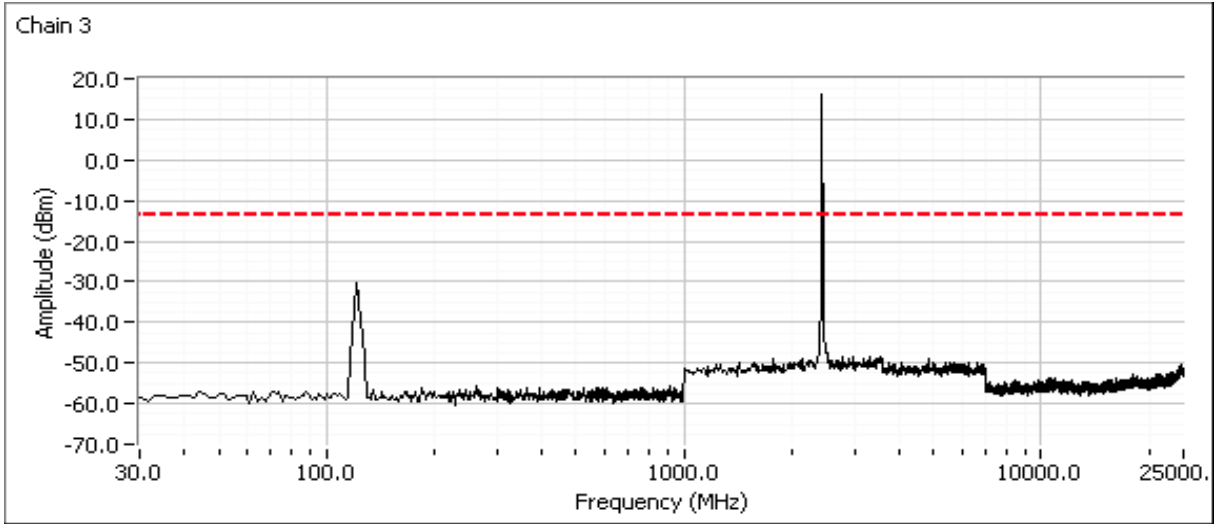
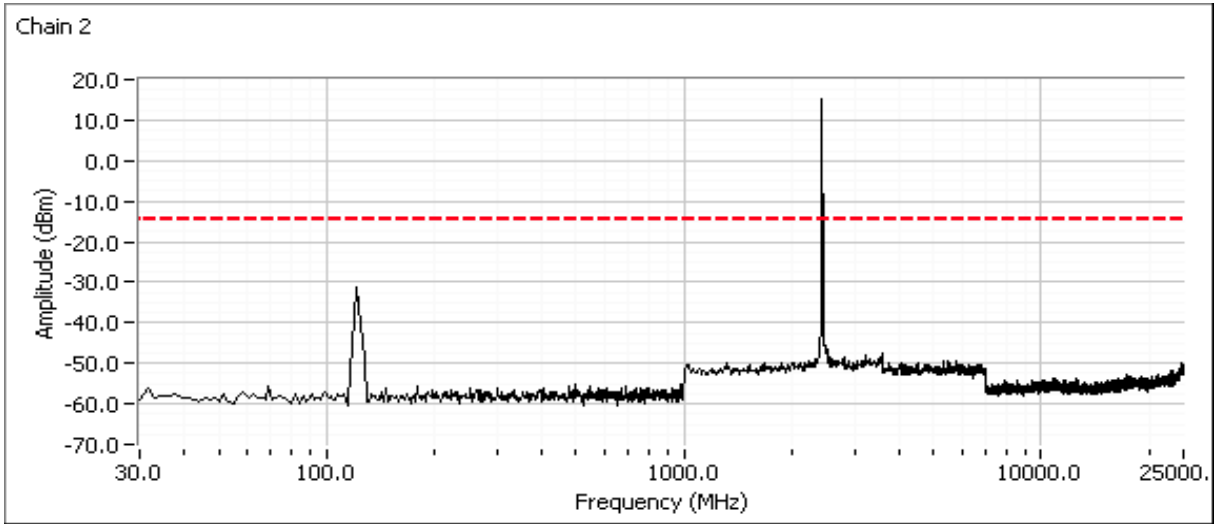

Client: Pace Americas, Inc.	Job Number: JD100298
Model: Wi-Fi Module 2.4 GHz	T-Log Number: T100355
	Project Manager: Irene Radamacher
Contact: Mark Rieger	Project Coordinator: -
Standard: FCC Part 15.247	Class: N/A

Plots for high channel, 802.11b Mode

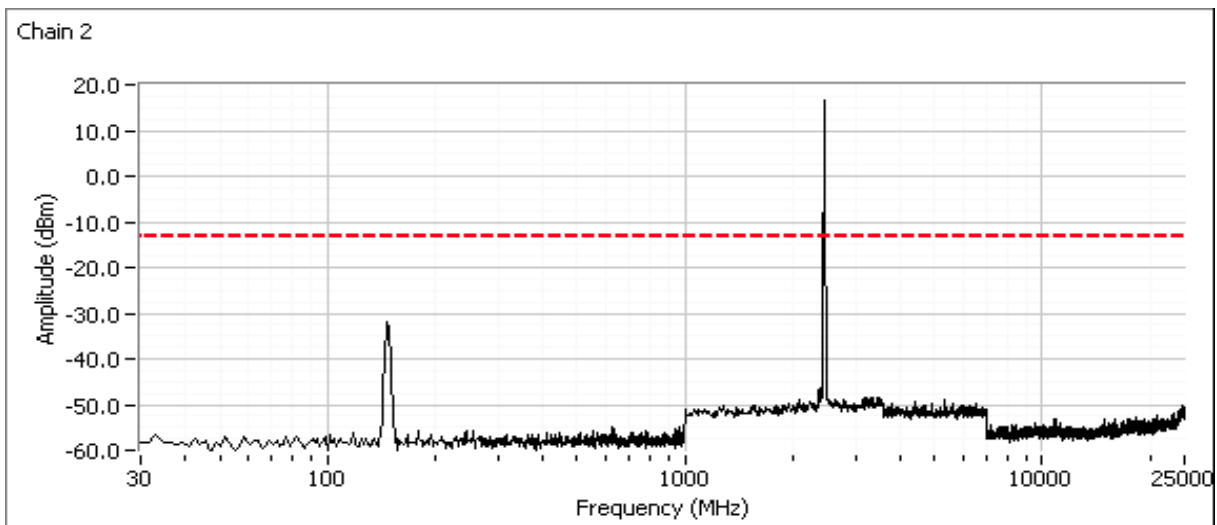
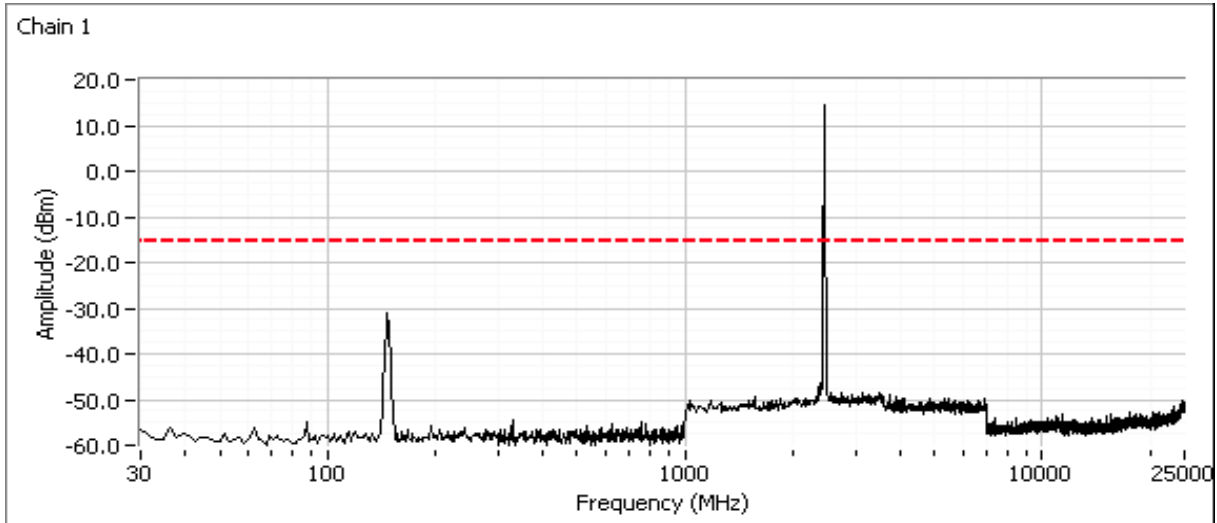

Client: Pace Americas, Inc.	Job Number: JD100298
Model: Wi-Fi Module 2.4 GHz	T-Log Number: T100355
	Project Manager: Irene Radamacher
Contact: Mark Rieger	Project Coordinator: -
Standard: FCC Part 15.247	Class: N/A

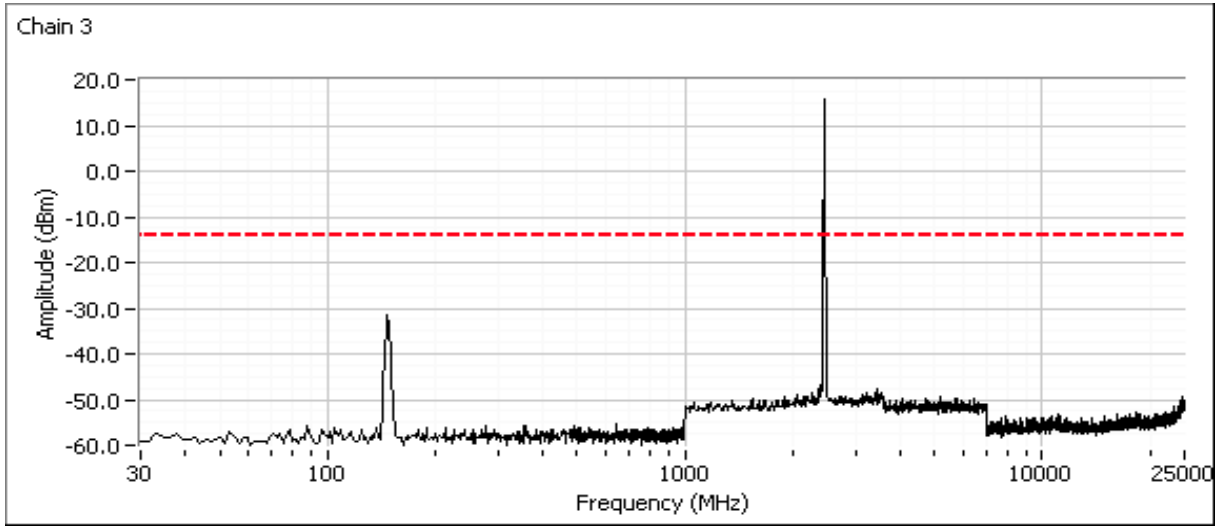

802.11g

Plots for low channel, 802.11g mode

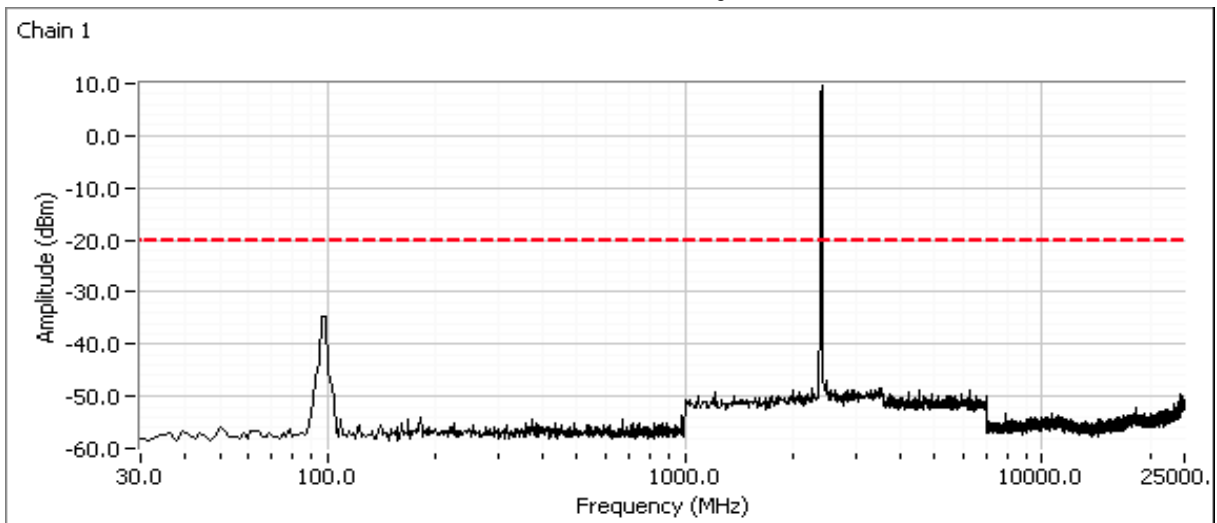

Client: Pace Americas, Inc.	Job Number: JD100298
Model: Wi-Fi Module 2.4 GHz	T-Log Number: T100355
Contact: Mark Rieger	Project Manager: Irene Radmacher
Standard: FCC Part 15.247	Project Coordinator: -
	Class: N/A

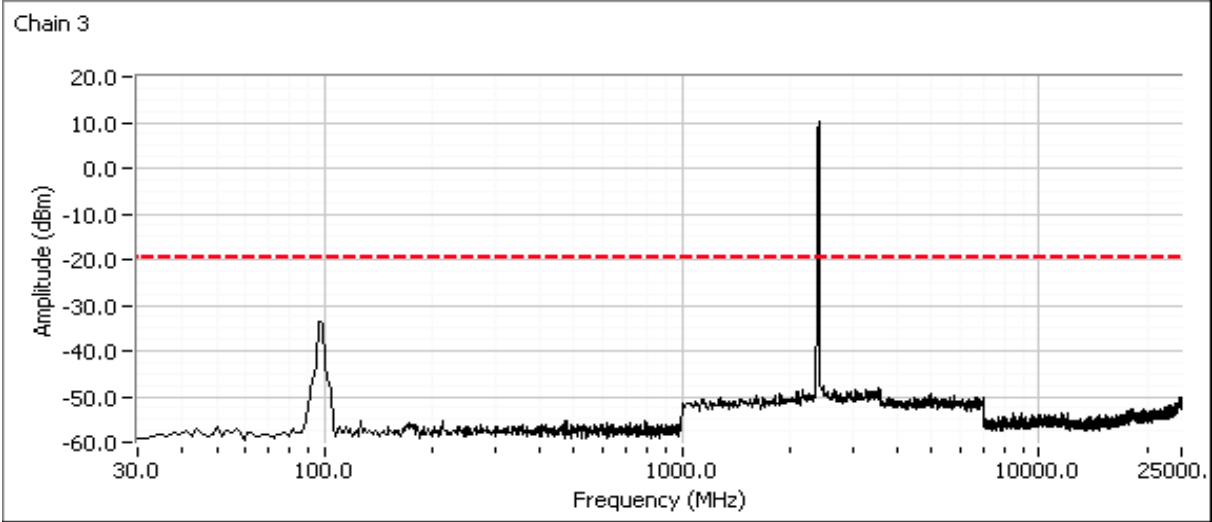
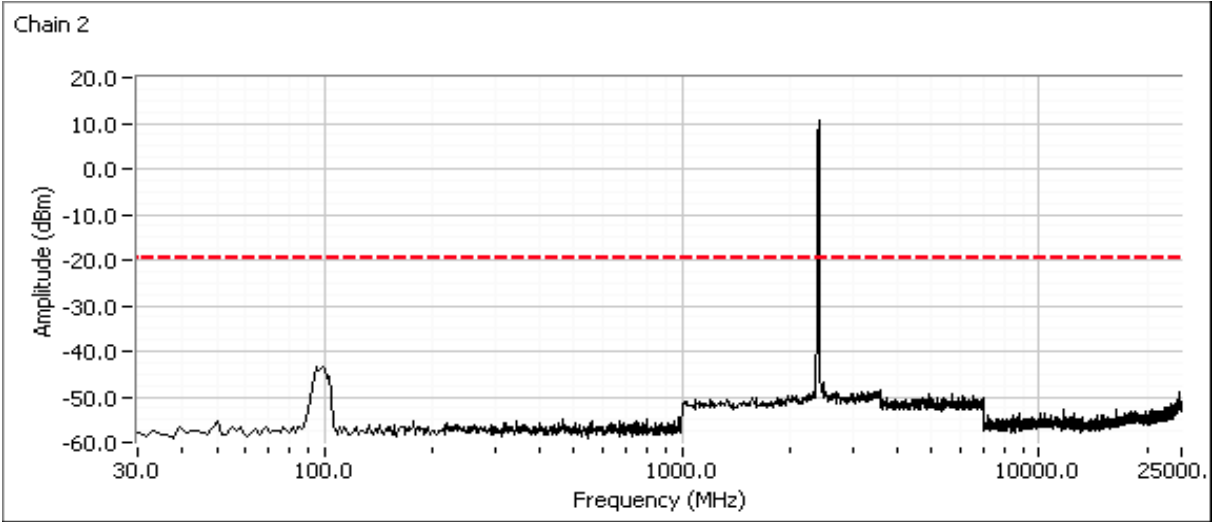

Client: Pace Americas, Inc.	Job Number: JD100298
Model: Wi-Fi Module 2.4 GHz	T-Log Number: T100355
	Project Manager: Irene Radamacher
Contact: Mark Rieger	Project Coordinator: -
Standard: FCC Part 15.247	Class: N/A

Additional plot showing compliance with -30dBc limit from 2390 MHz to 2400 MHz. Radiated measurements used to show compliance with the limits in the restricted band below 2390 MHz.

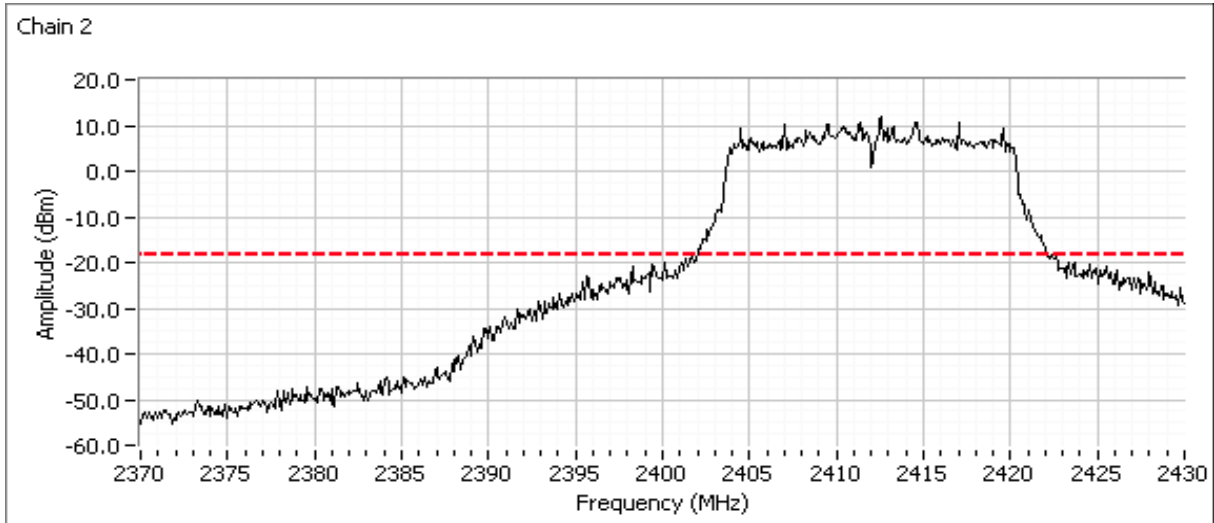
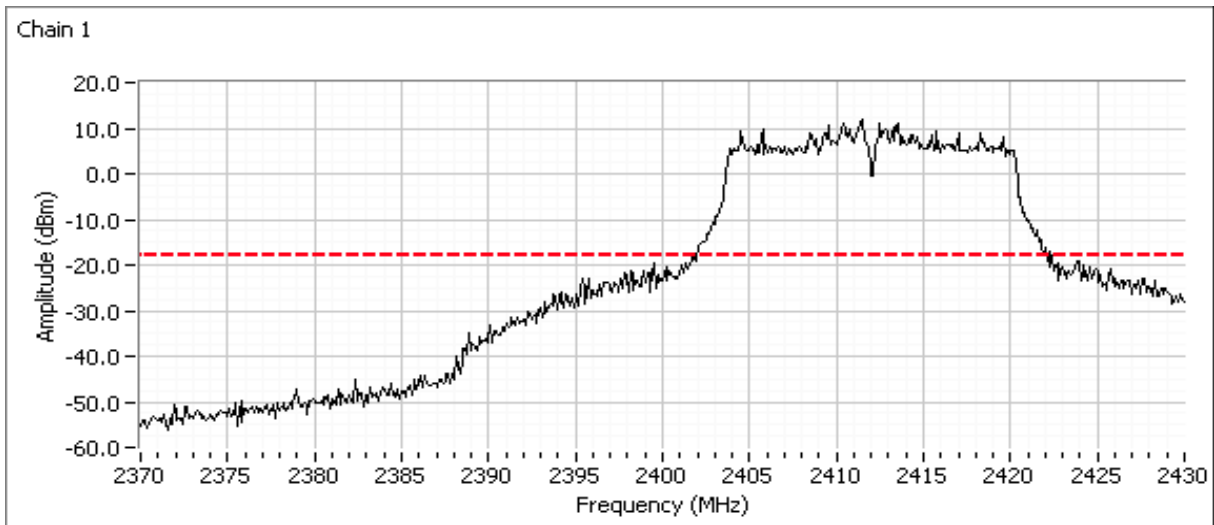

Client: Pace Americas, Inc.	Job Number: JD100298
Model: Wi-Fi Module 2.4 GHz	T-Log Number: T100355
	Project Manager: Irene Radmacher
Contact: Mark Rieger	Project Coordinator: -
Standard: FCC Part 15.247	Class: N/A

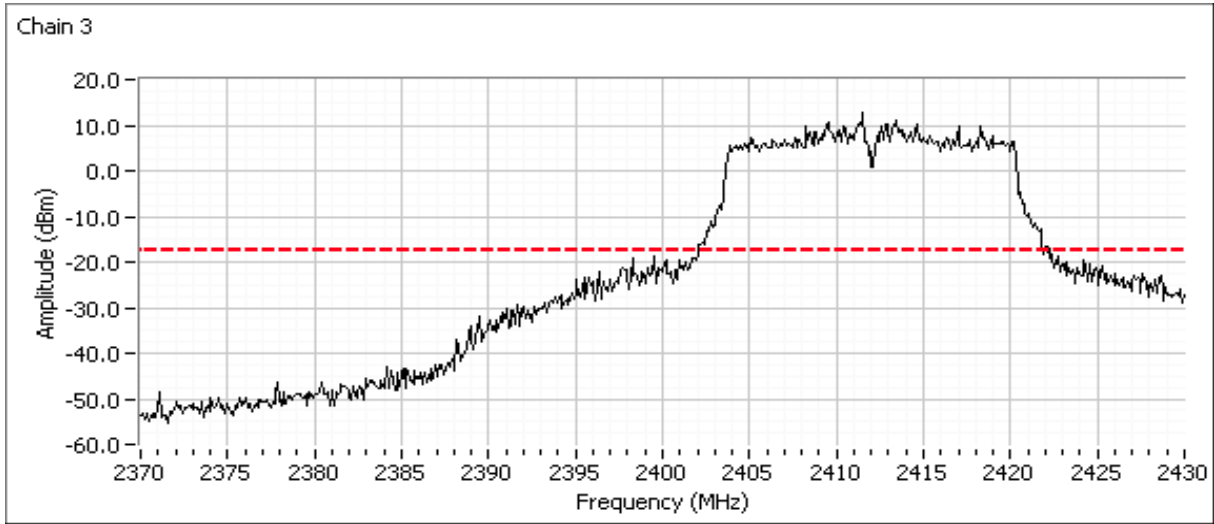

Plots for center channel, 802.11g Mode

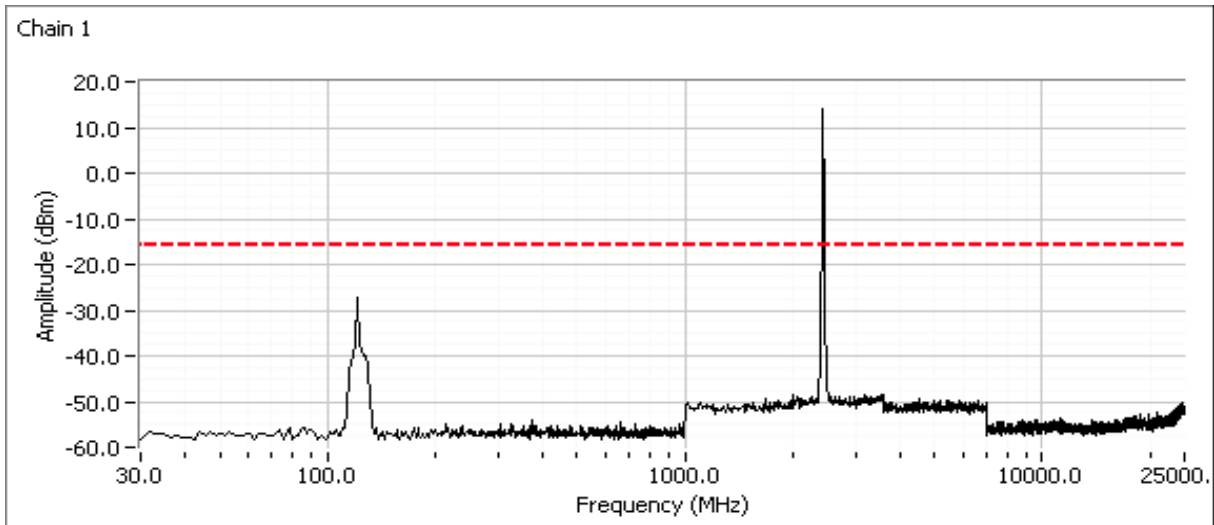

Client: Pace Americas, Inc.	Job Number: JD100298
Model: Wi-Fi Module 2.4 GHz	T-Log Number: T100355
	Project Manager: Irene Radmacher
Contact: Mark Rieger	Project Coordinator: -
Standard: FCC Part 15.247	Class: N/A

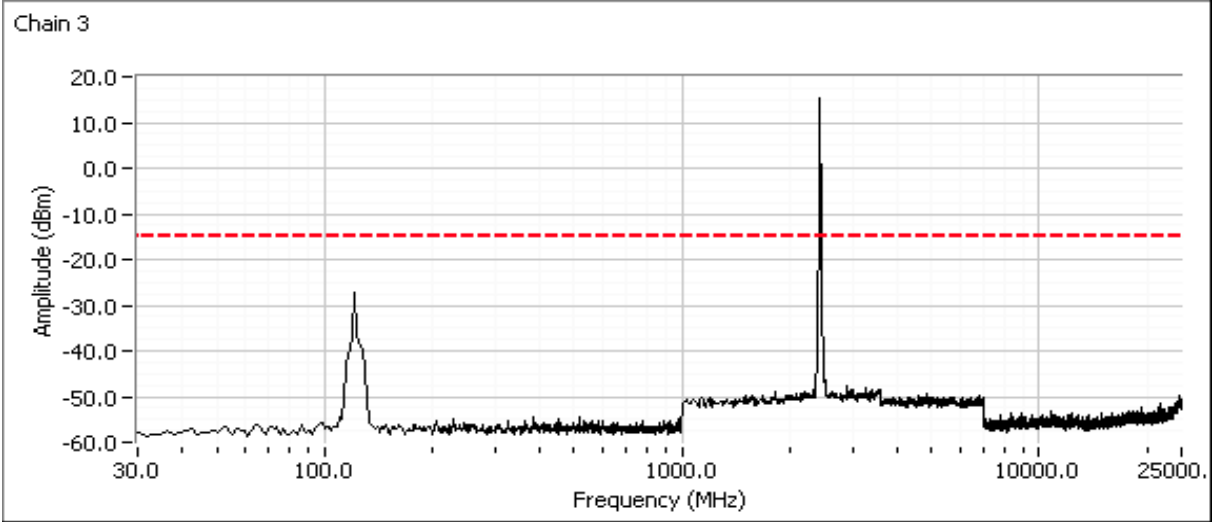
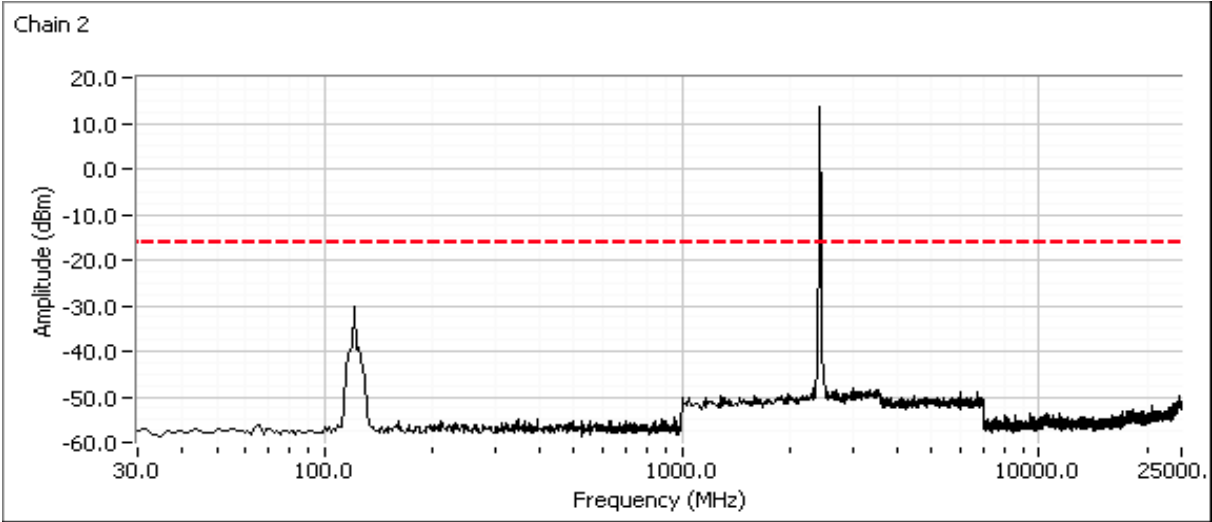

Client: Pace Americas, Inc.	Job Number: JD100298
Model: Wi-Fi Module 2.4 GHz	T-Log Number: T100355
	Project Manager: Irene Radmacher
Contact: Mark Rieger	Project Coordinator: -
Standard: FCC Part 15.247	Class: N/A

Plots for high channel, 802.11g Mode

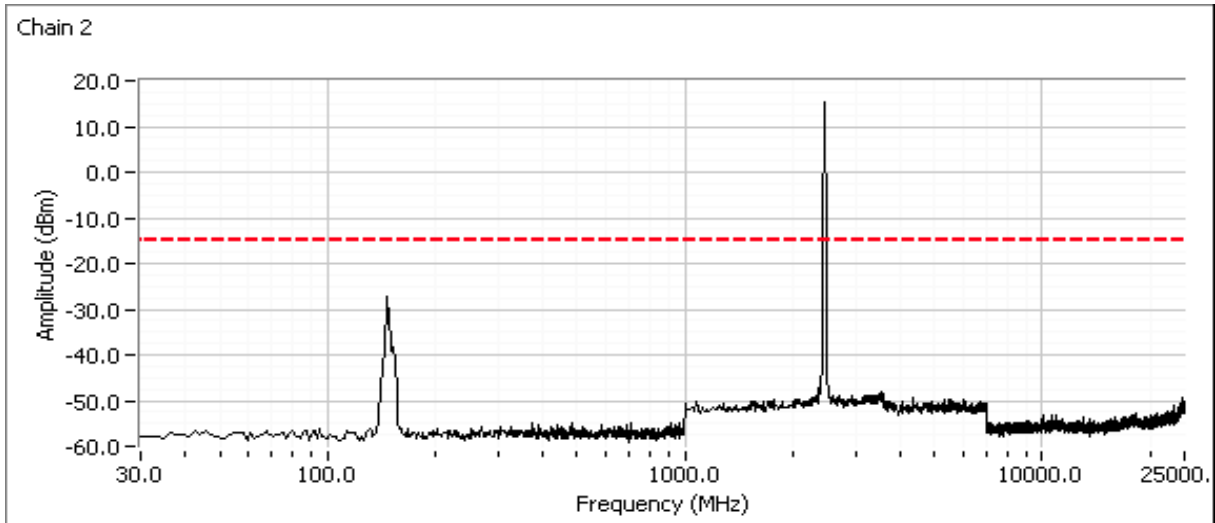
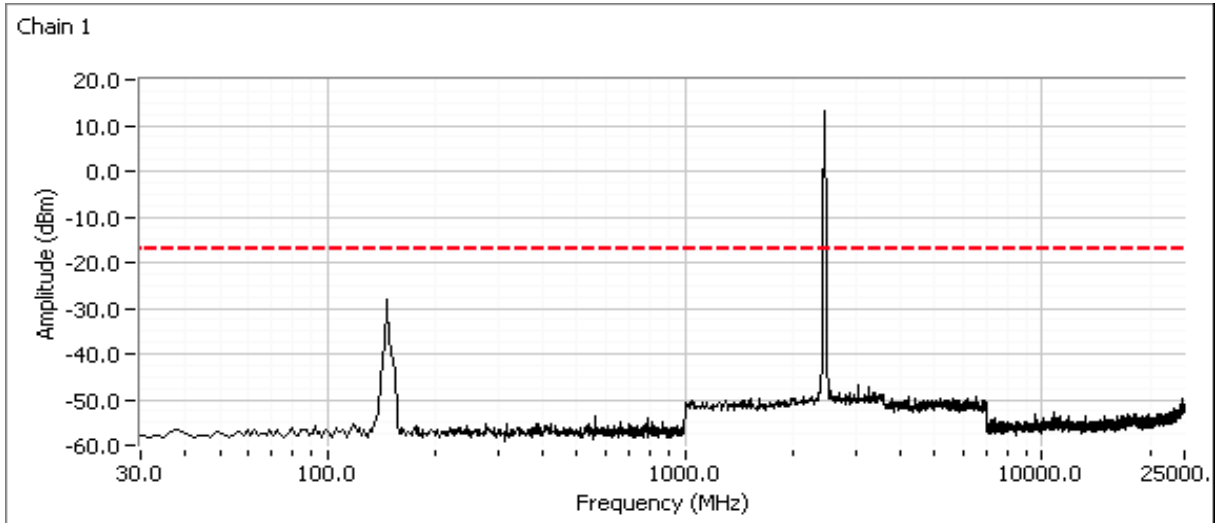

Client: Pace Americas, Inc.	Job Number: JD100298
Model: Wi-Fi Module 2.4 GHz	T-Log Number: T100355
	Project Manager: Irene Radamacher
Contact: Mark Rieger	Project Coordinator: -
Standard: FCC Part 15.247	Class: N/A

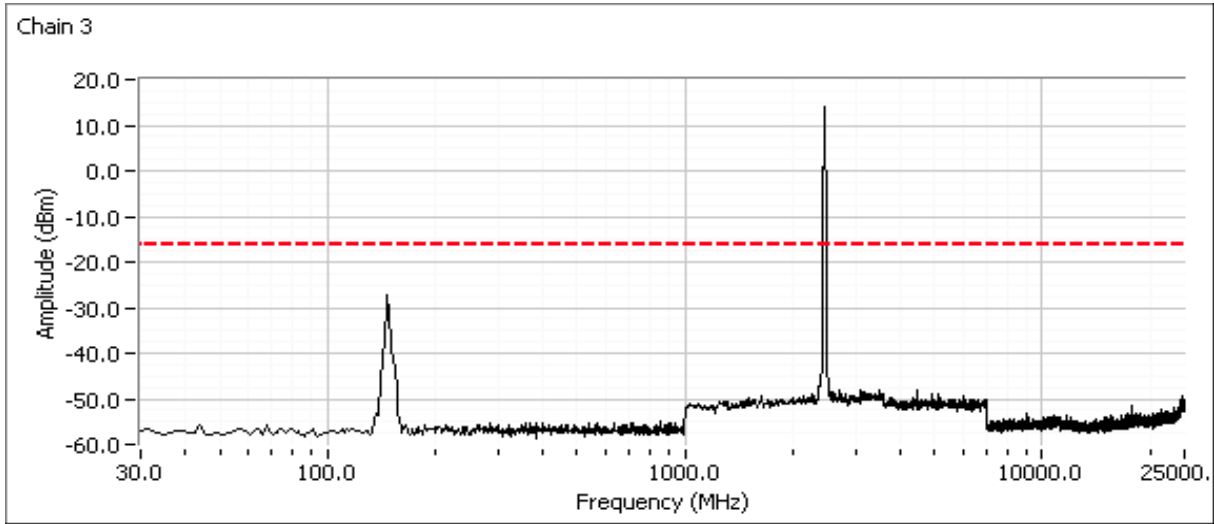

802.11n20

Plots for low channel, 802.11n20 mode

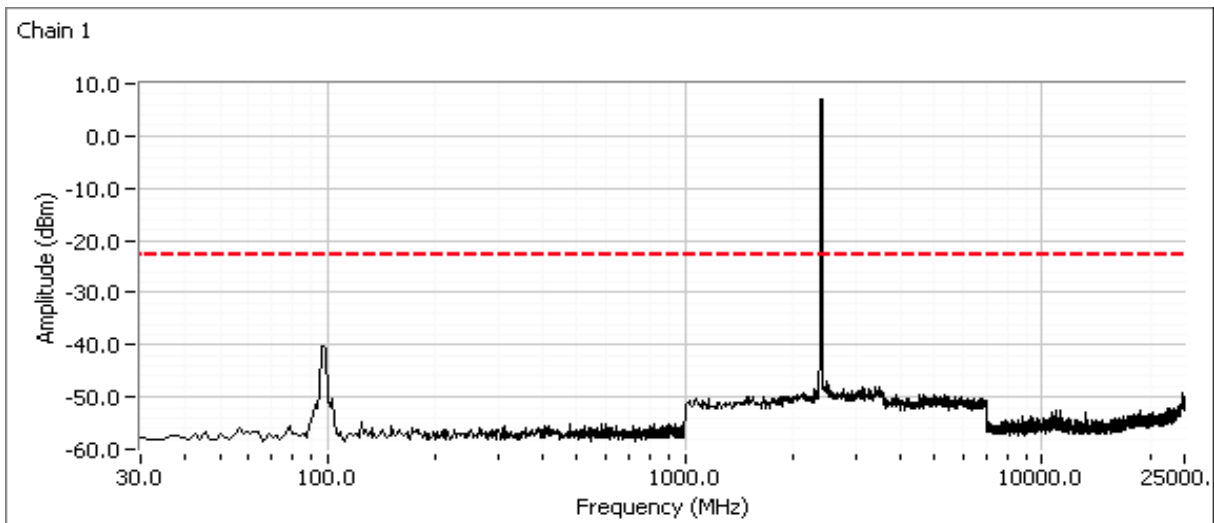

Client: Pace Americas, Inc.	Job Number: JD100298
Model: Wi-Fi Module 2.4 GHz	T-Log Number: T100355
	Project Manager: Irene Radamacher
Contact: Mark Rieger	Project Coordinator: -
Standard: FCC Part 15.247	Class: N/A

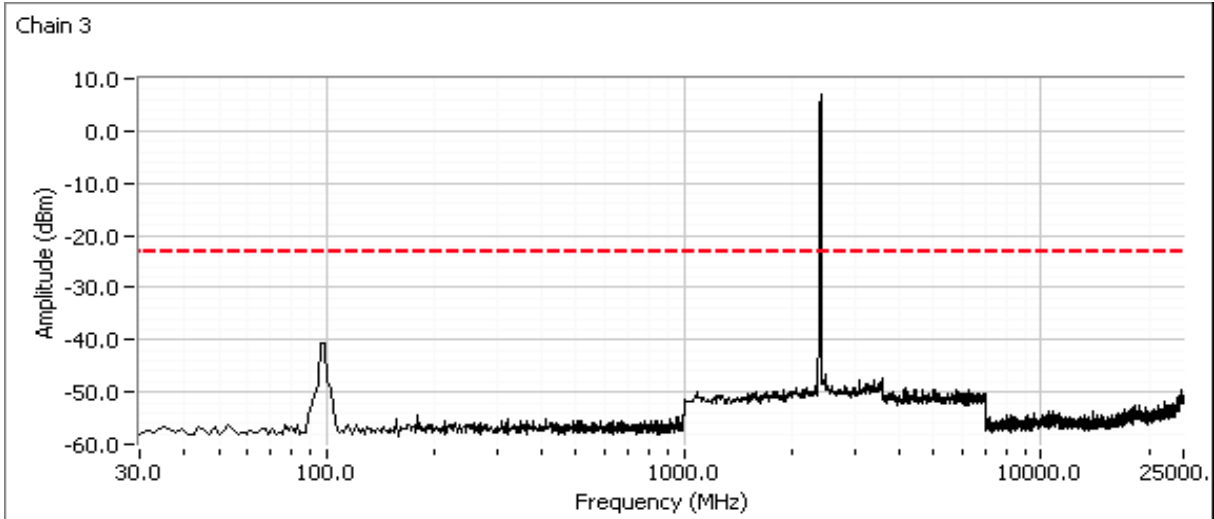
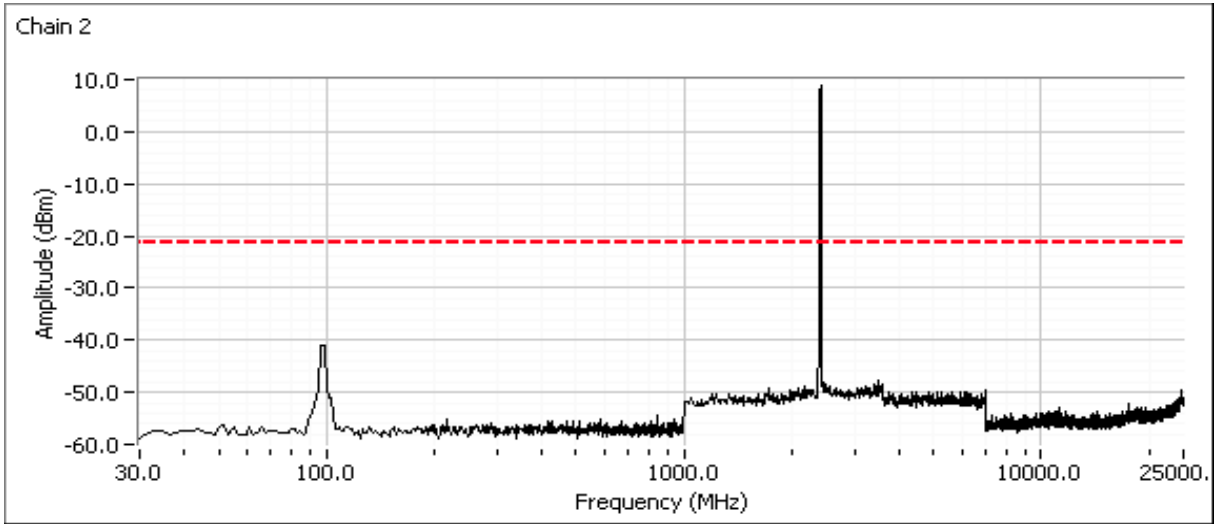

Client: Pace Americas, Inc.	Job Number: JD100298
Model: Wi-Fi Module 2.4 GHz	T-Log Number: T100355
	Project Manager: Irene Radmacher
Contact: Mark Rieger	Project Coordinator: -
Standard: FCC Part 15.247	Class: N/A

Additional plot showing compliance with -30dBc limit from 2390 MHz to 2400 MHz. Radiated measurements used to show compliance with the limits in the restricted band below 2390 MHz.

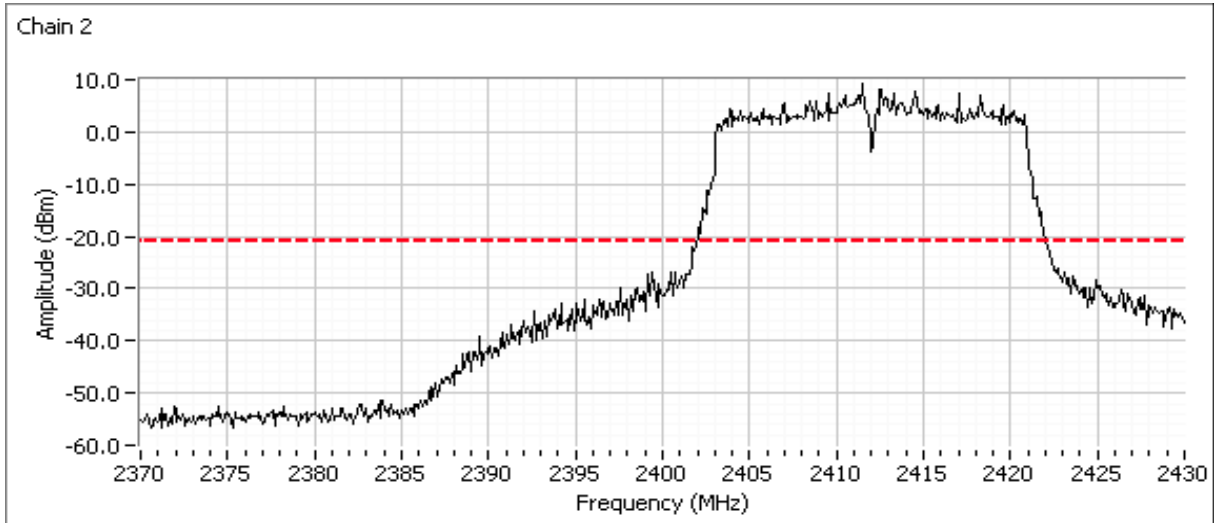
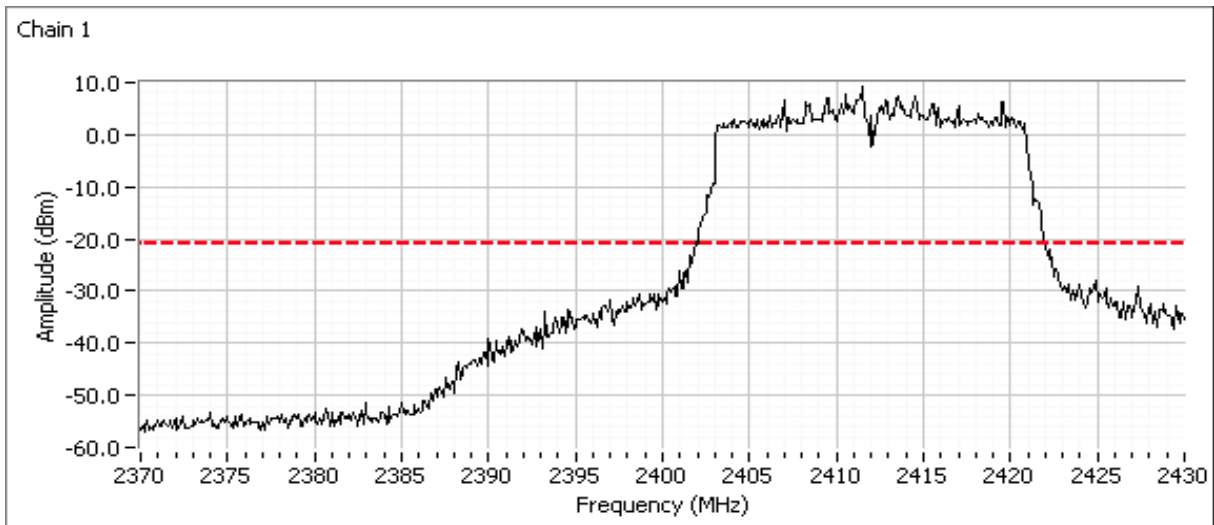

Client: Pace Americas, Inc.	Job Number: JD100298
Model: Wi-Fi Module 2.4 GHz	T-Log Number: T100355
Contact: Mark Rieger	Project Manager: Irene Radmacher
Standard: FCC Part 15.247	Project Coordinator: -
	Class: N/A

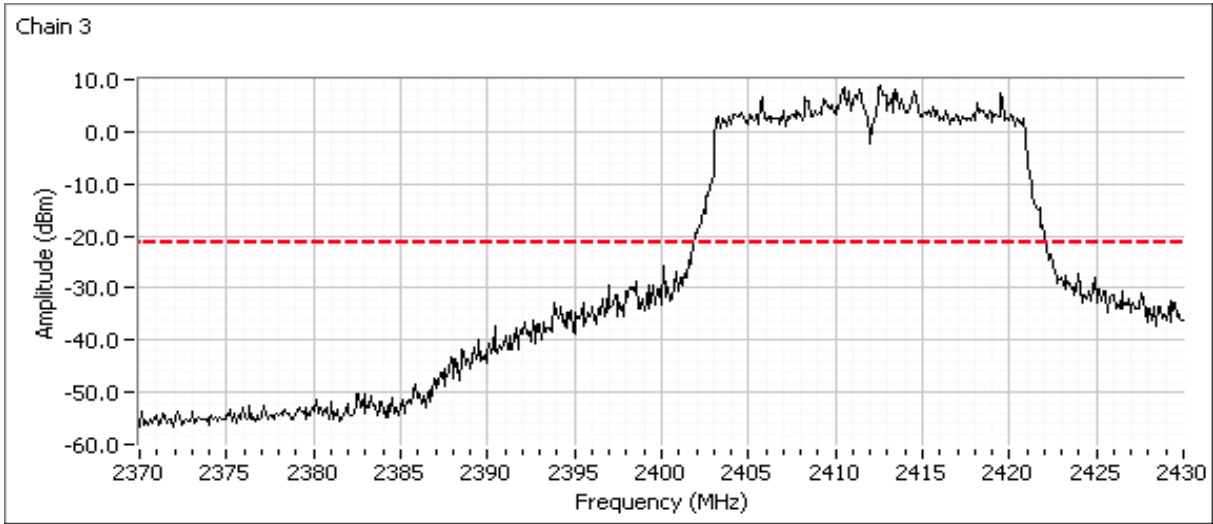

Plots for center channel, 802.11n20 mode

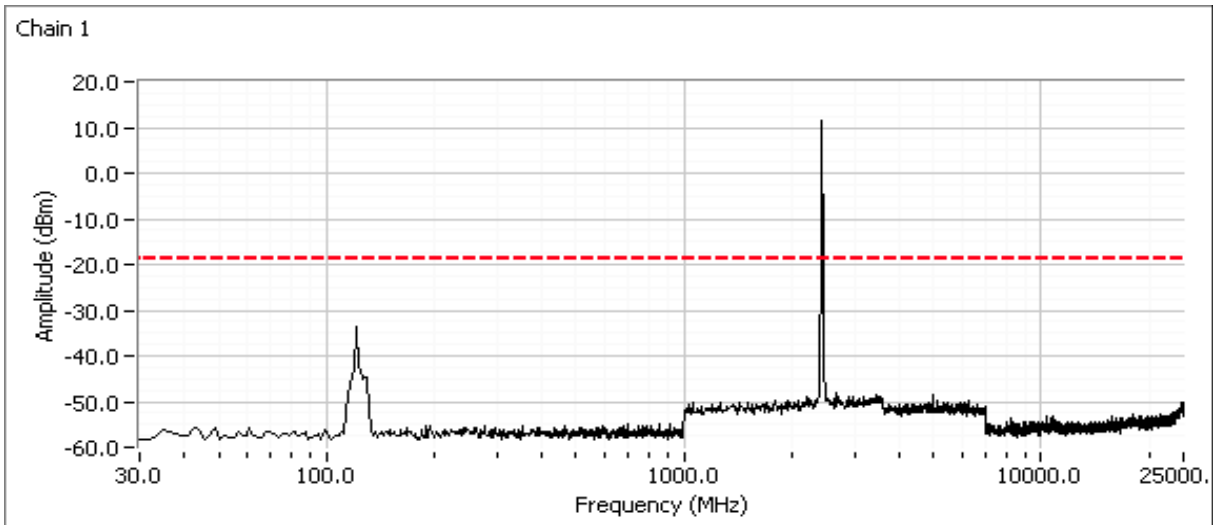

Client: Pace Americas, Inc.	Job Number: JD100298
Model: Wi-Fi Module 2.4 GHz	T-Log Number: T100355
	Project Manager: Irene Radmacher
Contact: Mark Rieger	Project Coordinator: -
Standard: FCC Part 15.247	Class: N/A

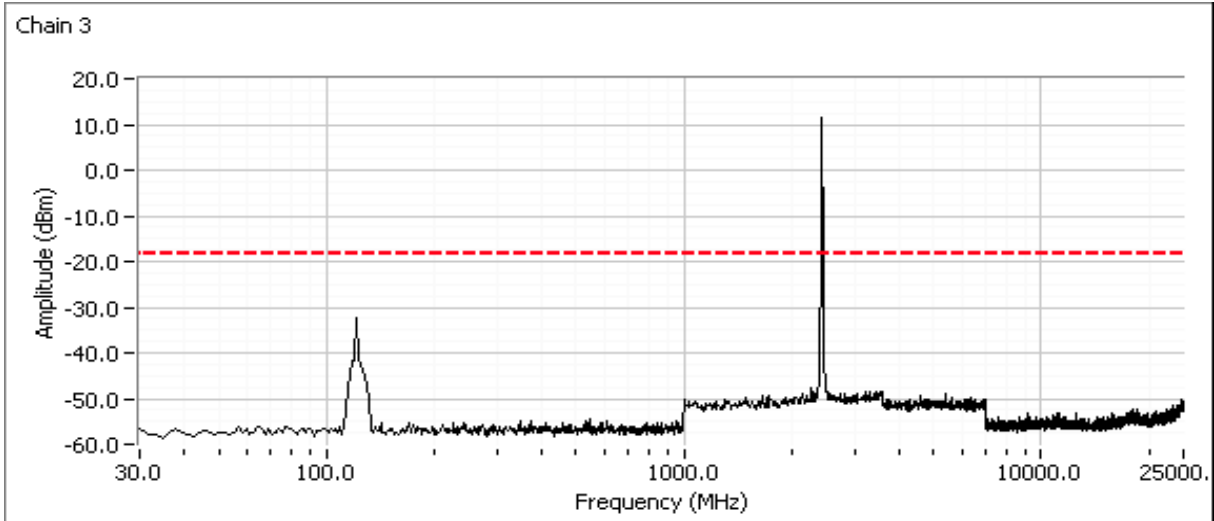
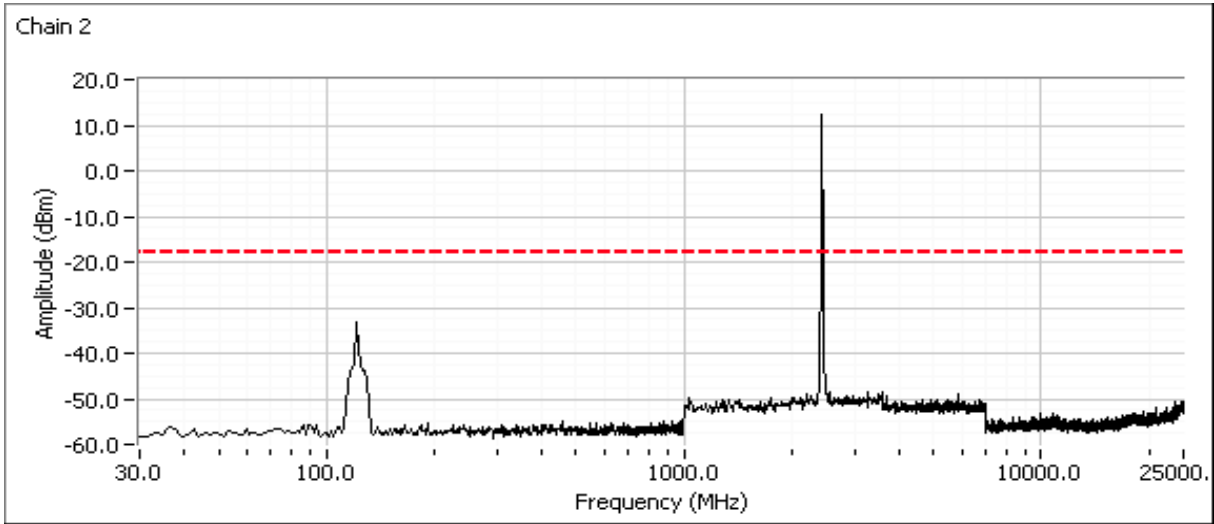

Client: Pace Americas, Inc.	Job Number: JD100298
Model: Wi-Fi Module 2.4 GHz	T-Log Number: T100355
	Project Manager: Irene Radamacher
Contact: Mark Rieger	Project Coordinator: -
Standard: FCC Part 15.247	Class: N/A

Plots for high channel, 802.11n20 mode

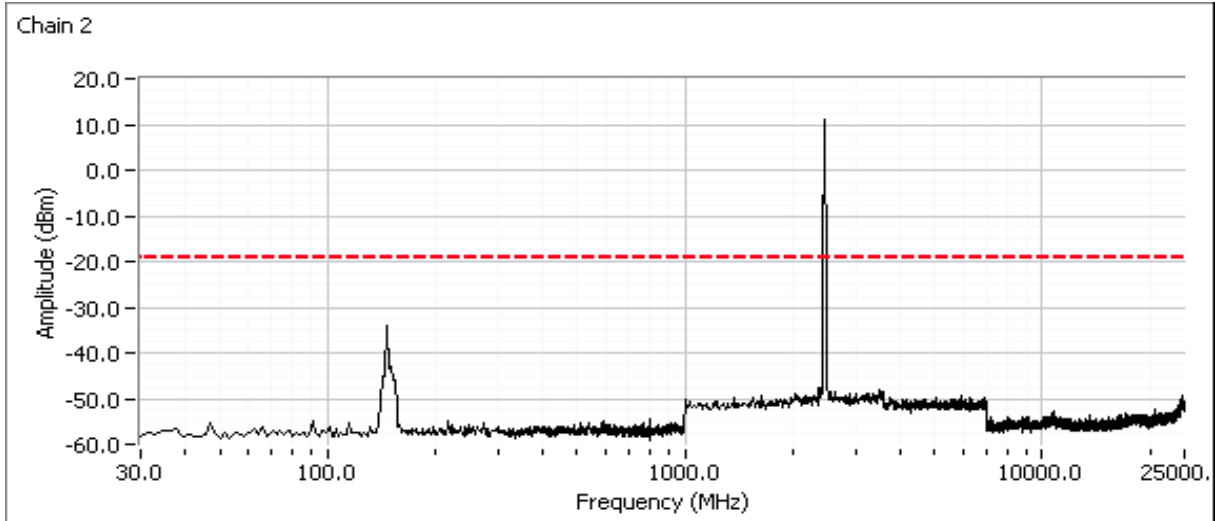
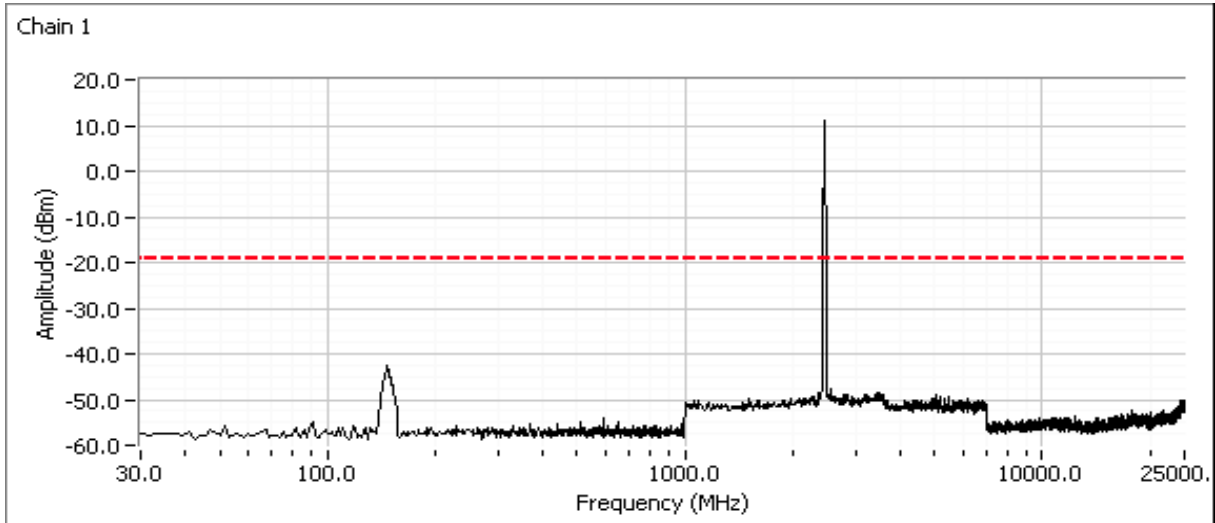

Client: Pace Americas, Inc.	Job Number: JD100298
Model: Wi-Fi Module 2.4 GHz	T-Log Number: T100355
Contact: Mark Rieger	Project Manager: Irene Radmacher
Standard: FCC Part 15.247	Project Coordinator: -
	Class: N/A

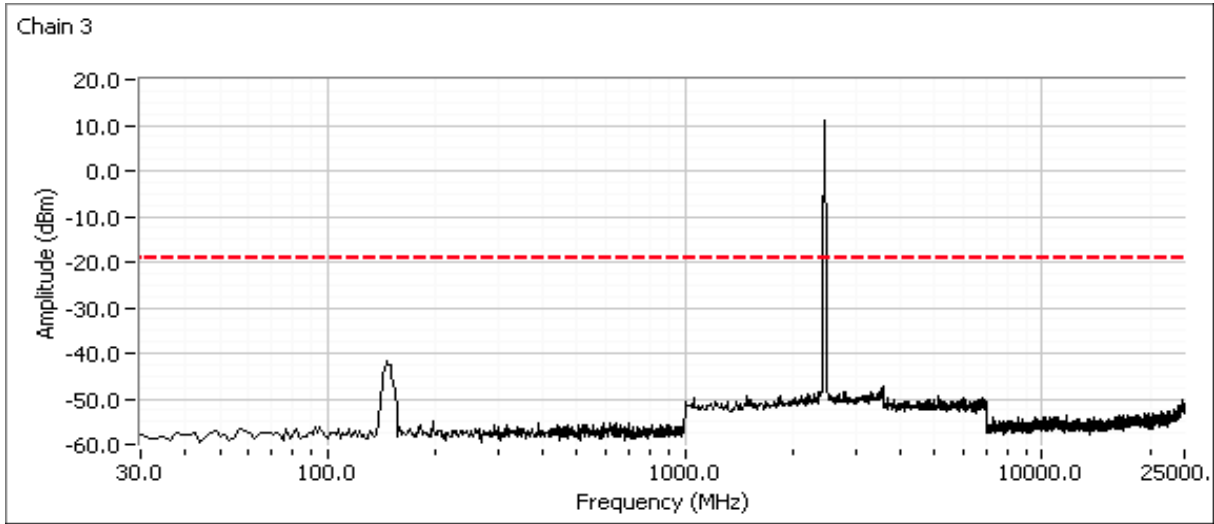

802.11n40

Plots for low channel, 802.11n40 mode

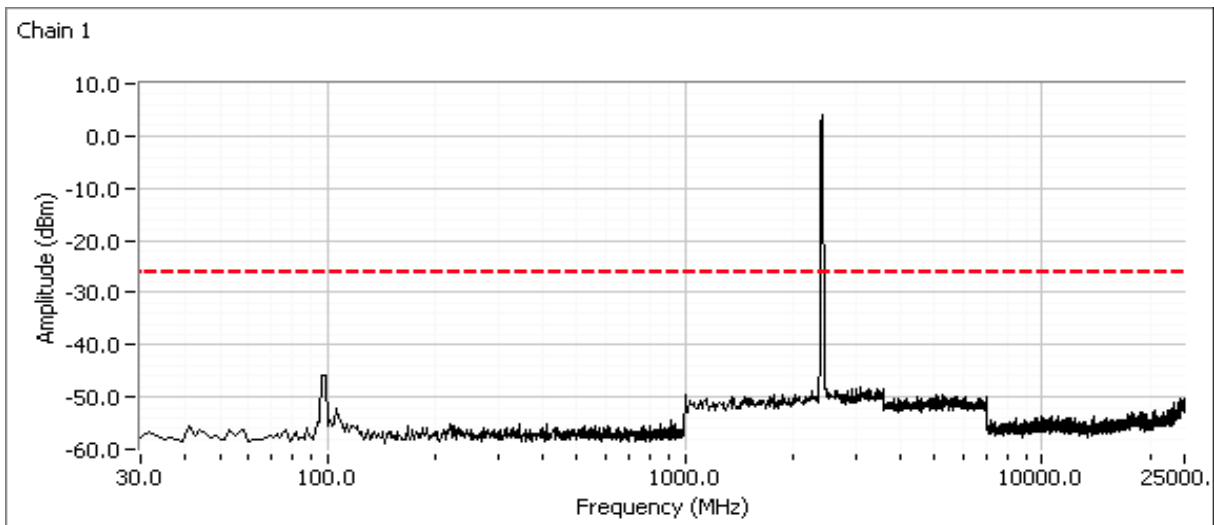

Client: Pace Americas, Inc.	Job Number: JD100298
Model: Wi-Fi Module 2.4 GHz	T-Log Number: T100355
	Project Manager: Irene Radmacher
Contact: Mark Rieger	Project Coordinator: -
Standard: FCC Part 15.247	Class: N/A

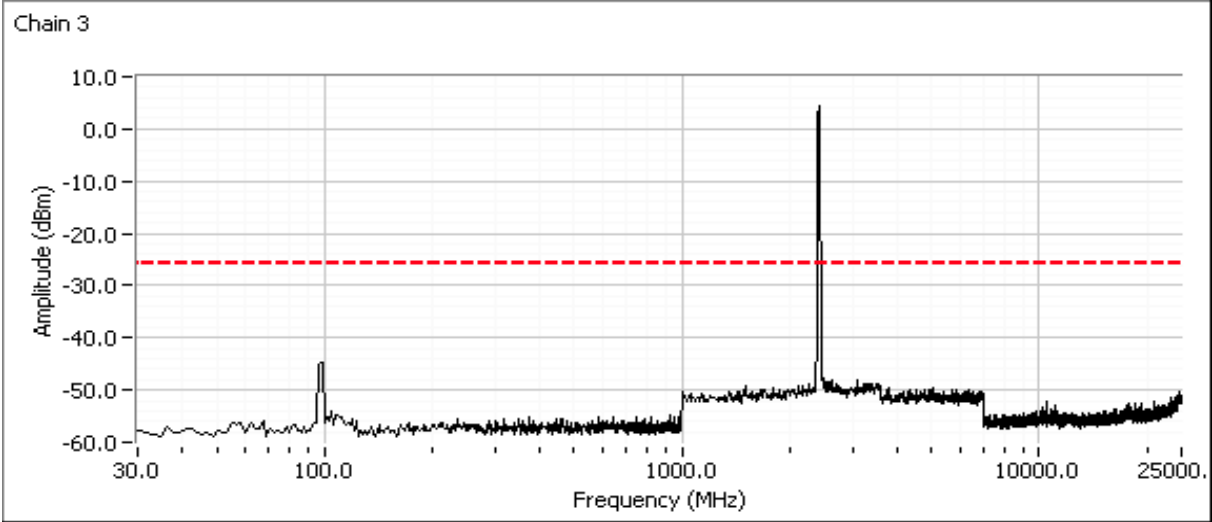
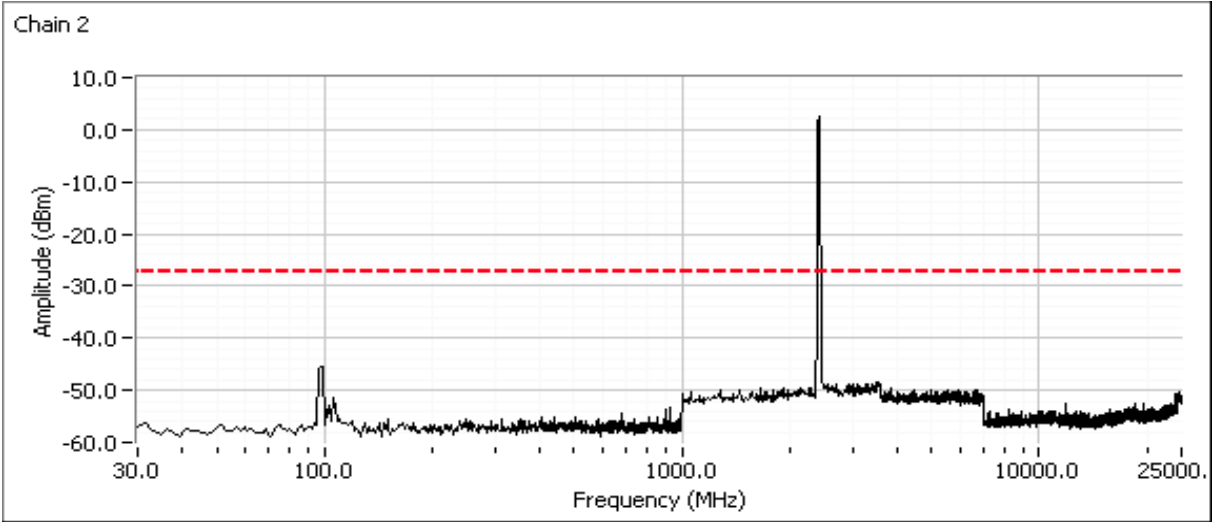

Client: Pace Americas, Inc.	Job Number: JD100298
Model: Wi-Fi Module 2.4 GHz	T-Log Number: T100355
	Project Manager: Irene Radamacher
Contact: Mark Rieger	Project Coordinator: -
Standard: FCC Part 15.247	Class: N/A

Additional plot showing compliance with -30dBc limit from 2390 MHz to 2400 MHz. Radiated measurements used to show compliance with the limits in the restricted band below 2390 MHz.

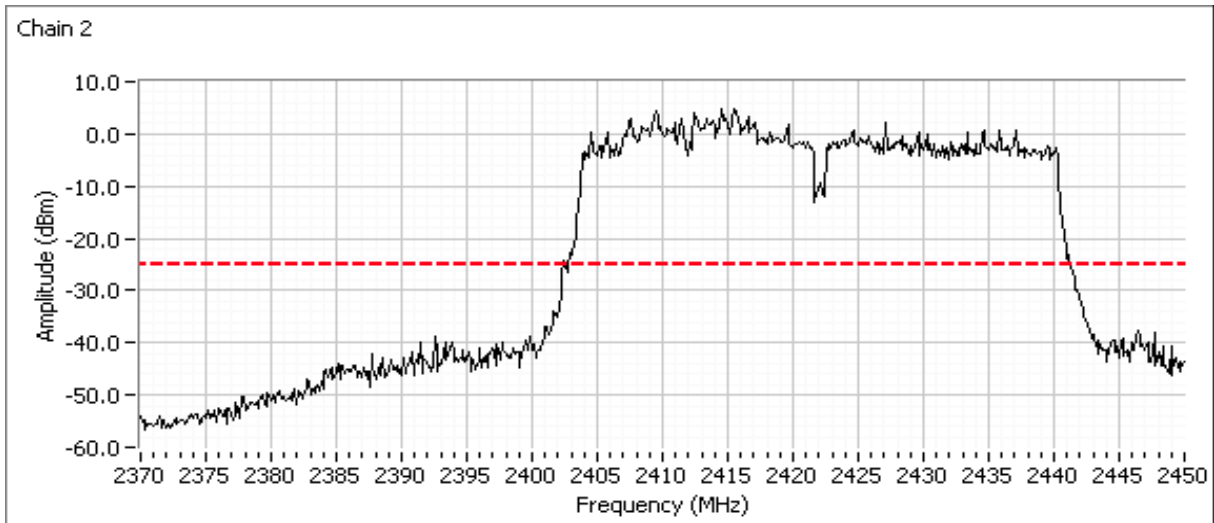
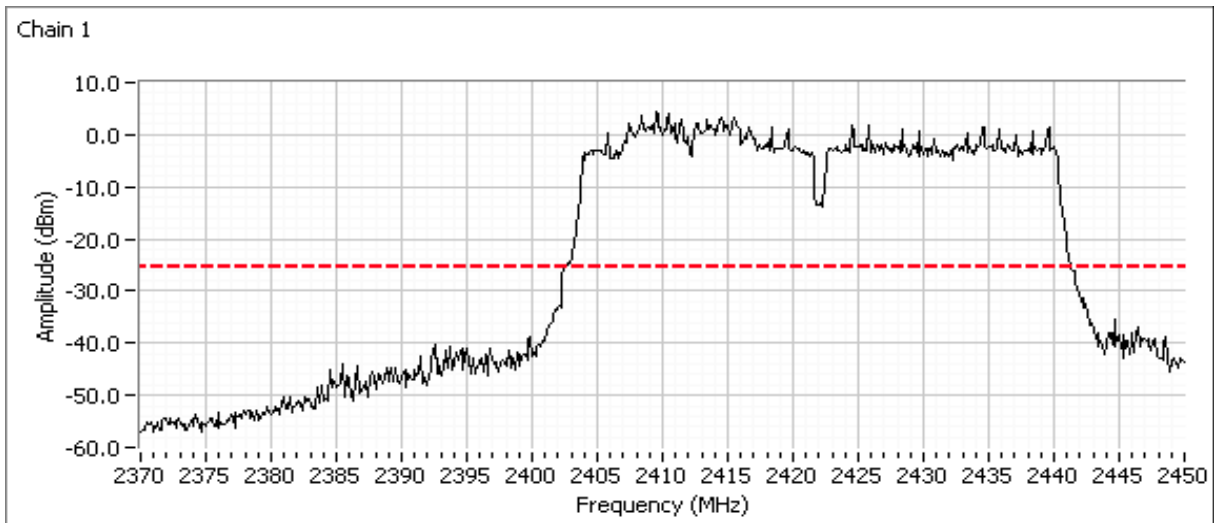

Client: Pace Americas, Inc.	Job Number: JD100298
Model: Wi-Fi Module 2.4 GHz	T-Log Number: T100355
	Project Manager: Irene Radmacher
Contact: Mark Rieger	Project Coordinator: -
Standard: FCC Part 15.247	Class: N/A

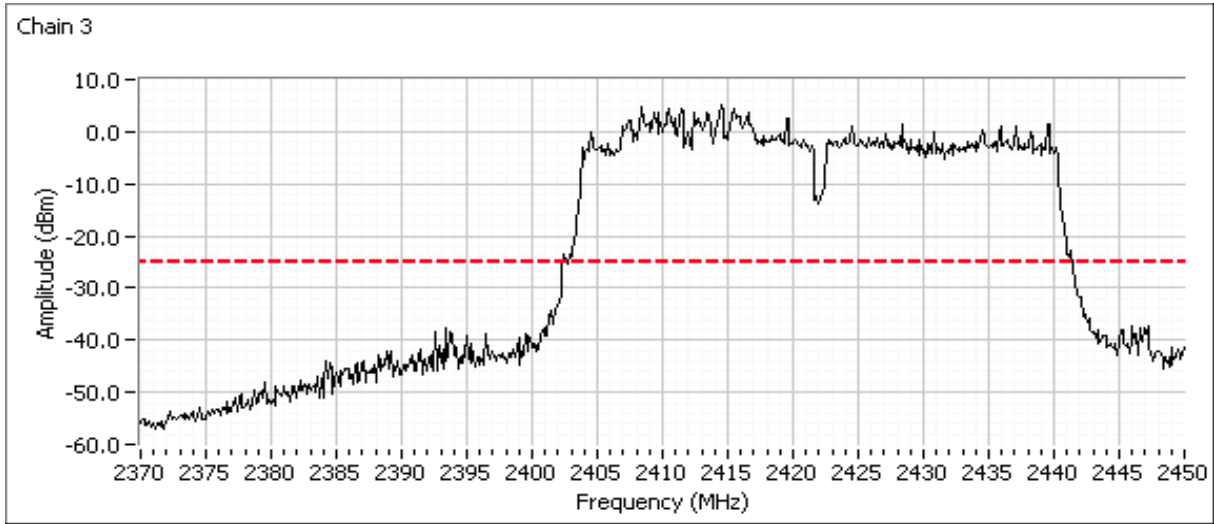

Plots for center channel, 802.11n40 mode

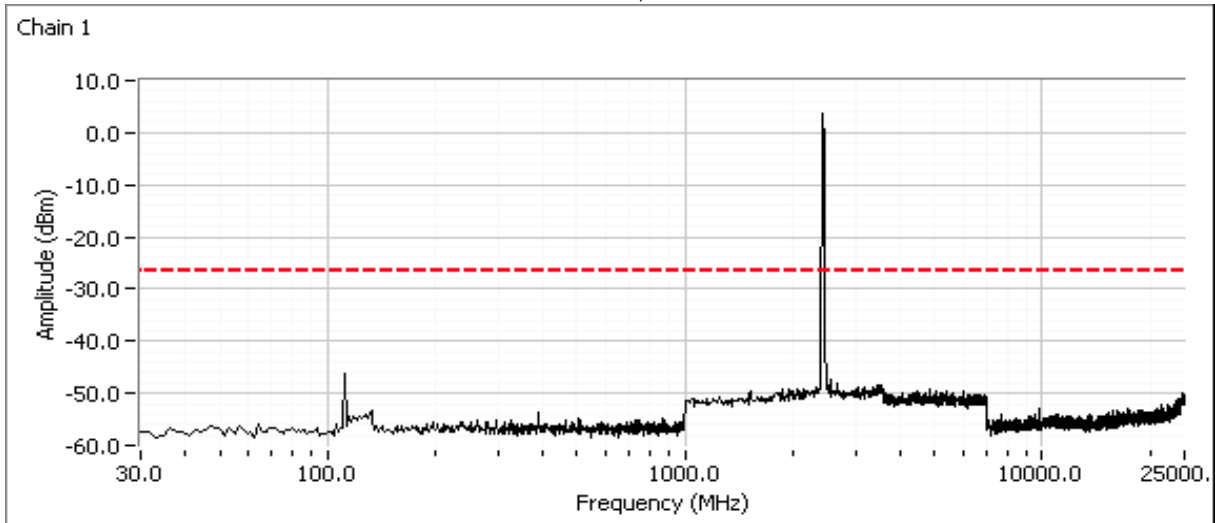

Client: Pace Americas, Inc.	Job Number: JD100298
Model: Wi-Fi Module 2.4 GHz	T-Log Number: T100355
	Project Manager: Irene Radmacher
Contact: Mark Rieger	Project Coordinator: -
Standard: FCC Part 15.247	Class: N/A

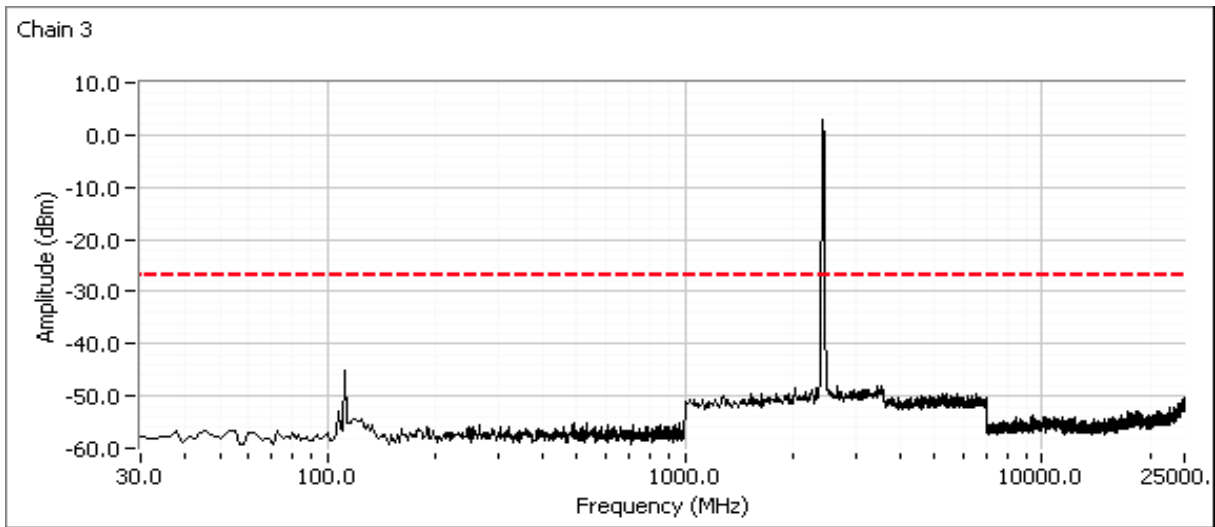
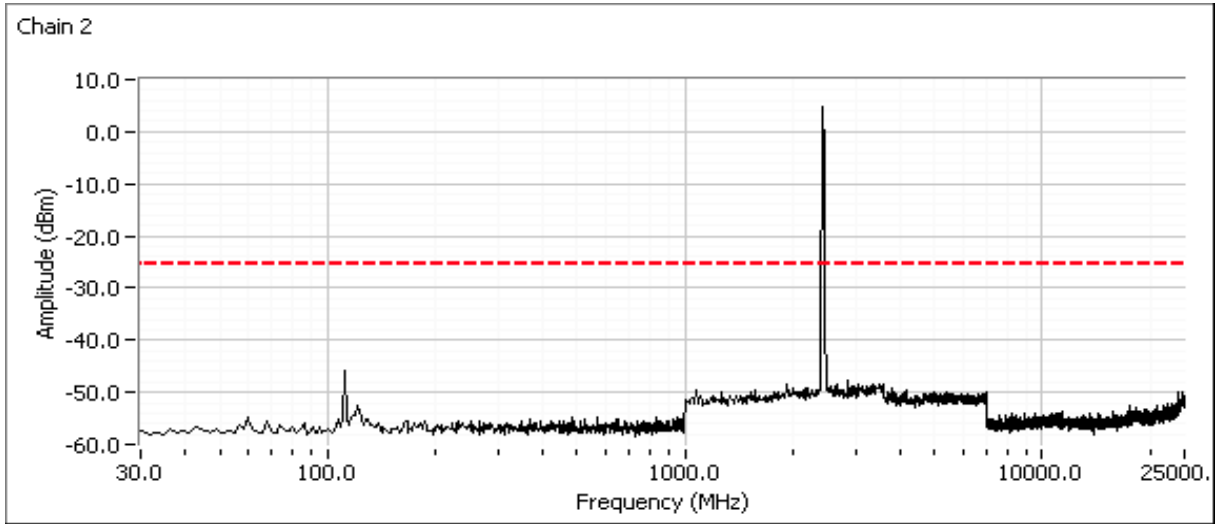

Client: Pace Americas, Inc.	Job Number: JD100298
Model: Wi-Fi Module 2.4 GHz	T-Log Number: T100355
	Project Manager: Irene Radamacher
Contact: Mark Rieger	Project Coordinator: -
Standard: FCC Part 15.247	Class: N/A

Plots for high channel, 802.11n40 Mode

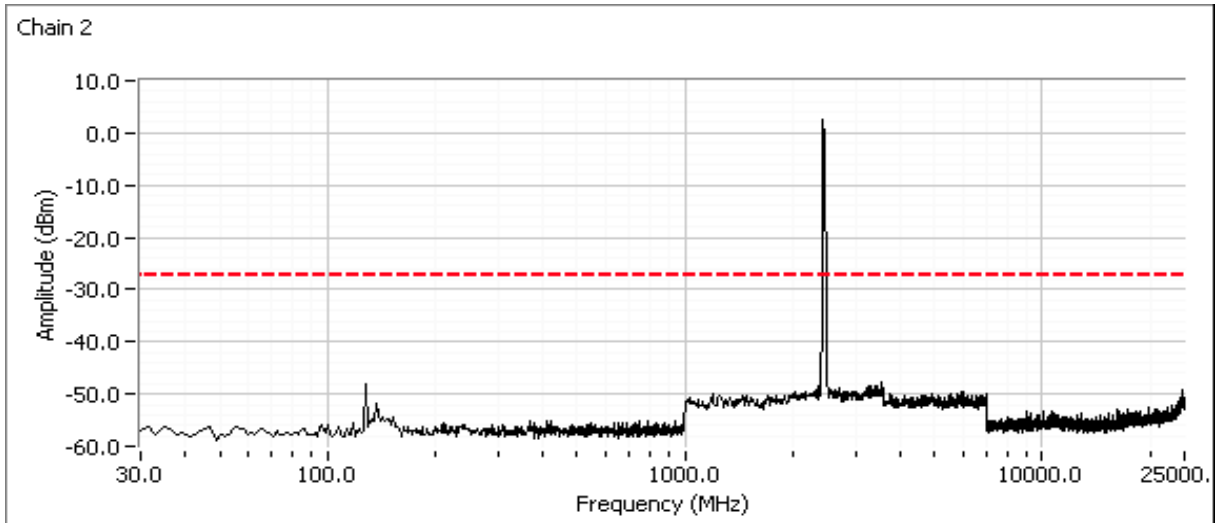
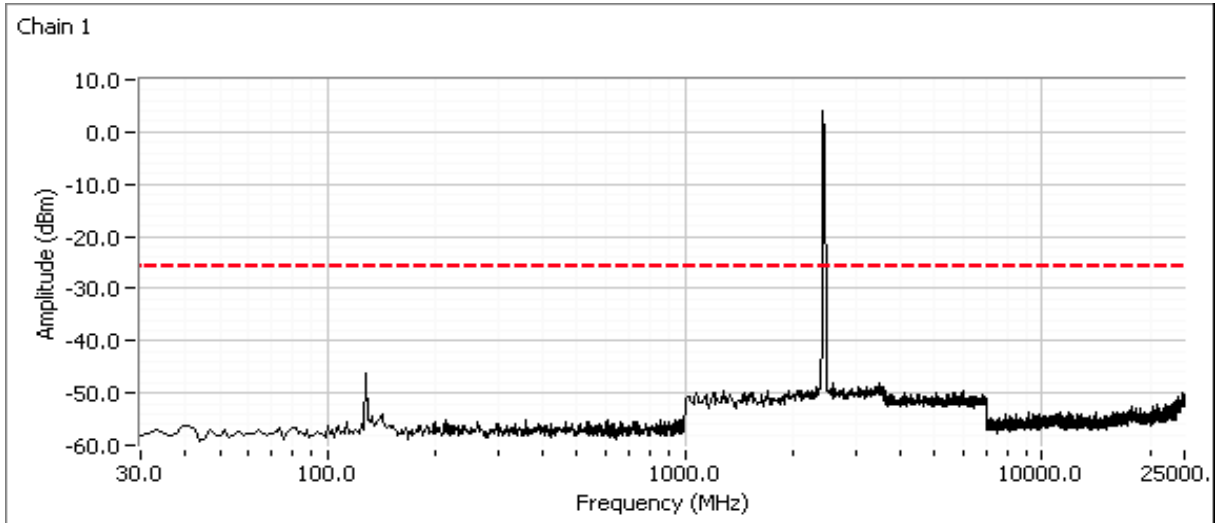

Client: Pace Americas, Inc.	Job Number: JD100298
Model: Wi-Fi Module 2.4 GHz	T-Log Number: T100355
	Project Manager: Irene Radamacher
Contact: Mark Rieger	Project Coordinator: -
Standard: FCC Part 15.247	Class: N/A

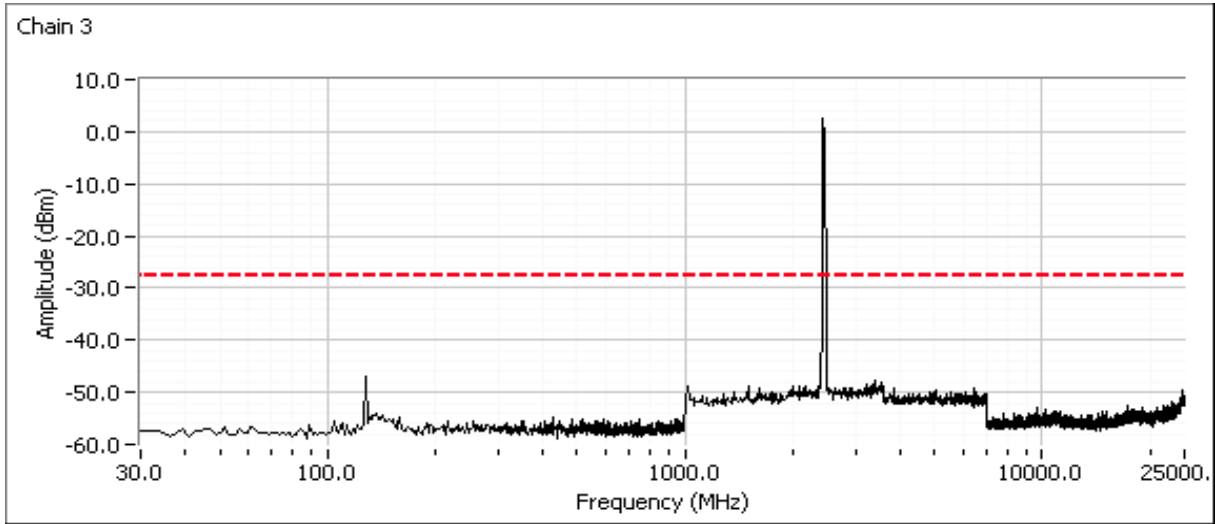



EMC Test Data

Client:	Pace Americas, Inc.	Job Number:	JD100298
Model:	Wi-Fi Module 2.4 GHz	T-Log Number:	T100355
		Project Manager:	Irene Radamacher
Contact:	Mark Rieger	Project Coordinator:	-
Standard:	FCC Part 15.247	Class:	N/A

RSS-247 and FCC 15.247 (DTS) Radiated Spurious Emissions

Test Specific Details

Objective: The objective of this test session is to perform final qualification testing of the EUT with respect to the specification listed above.

General Test Configuration

The EUT and all local support equipment were located on the turntable for radiated spurious emissions testing. For radiated emissions testing the measurement antenna was located 3 meters from the EUT, unless otherwise noted.

Ambient Conditions:

Temperature: 19.8 °C
Rel. Humidity: 34 %

Summary of Results - Device Operating in the 2400-2483.5 MHz Band

Run #	Mode	Channel	Target Power	Power Setting	Test Performed	Limit	Result / Margin
3	n20	1 - 2412MHz	24.5	20.0	Restricted Band Edge (2390 MHz)	FCC Part 15.209 / 15.247(c)	53.8 dBµV/m @ 2389.5 MHz (-0.2 dB)
	n20	2 - 2417MHz	24.5	24.0	Restricted Band Edge (2390 MHz)	FCC Part 15.209 / 15.247(c)	73.4 dBµV/m @ 2385.7 MHz (-0.6 dB)
	n20	10 - 2457MHz	24.5	23.0	Restricted Band Edge (2483.5 MHz)	FCC Part 15.209 / 15.247(c)	73.2 dBµV/m @ 2483.6 MHz (-0.8 dB)
	n20	11 - 2462MHz	24.5	17.5	Restricted Band Edge (2483.5 MHz)	FCC Part 15.209 / 15.247(c)	53.1 dBµV/m @ 2483.5 MHz (-0.9 dB)
4	n40	3 - 2422MHz	24.5	17.5	Restricted Band Edge (2390 MHz)	FCC Part 15.209 / 15.247(c)	53.9 dBµV/m @ 2389.0 MHz (-0.1 dB)
	n40	6 - 2437MHz	24.5	17.5	Restricted Band Edge (2390 MHz)	FCC Part 15.209 / 15.247(c)	51.6 dBµV/m @ 2483.5 MHz (-2.4 dB)
	n40	7 - 2442MHz	24.5	15.5	Restricted Band Edge (2483.5 MHz)	FCC Part 15.209 / 15.247(c)	51.2 dBµV/m @ 2483.7 MHz (-2.8 dB)
	n40	8 - 2447MHz	24.5	14.5	Restricted Band Edge (2390 MHz)	FCC Part 15.209 / 15.247(c)	51.9 dBµV/m @ 2483.5 MHz (-2.1 dB)
	n40	9 - 2452MHz -	24.5	14.5	Restricted Band Edge (2483.5 MHz)	FCC Part 15.209 / 15.247(c)	53.2 dBµV/m @ 2483.8 MHz (-0.8 dB)



EMC Test Data

Client:	Pace Americas, Inc.	Job Number:	JD100298
Model:	Wi-Fi Module 2.4 GHz	T-Log Number:	T100355
		Project Manager:	Irene Radamacher
Contact:	Mark Rieger	Project Coordinator:	-
Standard:	FCC Part 15.247	Class:	N/A

Modifications Made During Testing

No modifications were made to the EUT during testing

Deviations From The Standard

No deviations were made from the requirements of the standard.

Sample Notes

Sample S/N: N3193327100

Driver: 2.24 BL 2.56 SW

Antenna: 3 Tx (Beamforming modes)

Procedure Comments:

Measurements performed in accordance with FCC KDB 558074

Peak measurements performed with: RBW=1MHz, VBW=3MHz, peak detector, max hold, auto sweep time

Unless otherwise stated/noted, emission has a duty cycle $\geq 98\%$ and was measured using RBW=1MHz, VBW=10Hz, peak detector, linear average mode, auto sweep time, max hold.

Mode	Data Rate	Duty Cycle (x)	Constant DC?	T (ms)	Pwr Cor Factor*	Lin Volt Cor Factor**	Min VBW for FS (Hz)
n20	MCS0	0.97	Y	3.841	0.1	0.3	260
n40	MCS0	0.97	Y	4.575	0.1	0.2	219

Measurement Specific Notes:

Note 1:	Emission in non-restricted band, but limit of 15.209 used.
Note 2:	Emission in non-restricted band, the limit was set 30dB below the level of the fundamental and measured in 100kHz.
Note 3:	Emission has a duty cycle $\geq 98\%$, average measurement performed: RBW=1MHz, VBW=3MHz, RMS, Power averaging, auto sweep, trace average 100 traces
Note 4:	Emission has constant duty cycle $< 98\%$, average measurement performed: RBW=1MHz, VBW> $> 1/T$ but not less than 10Hz, peak detector, linear averaging, auto sweep, trace average 100 traces, measurement corrected by Linear voltage correction factor
Note 5:	Emission has constant duty cycle $< 98\%$, average measurement performed: RBW=1MHz, VBW=3MHz, RMS, Power averaging, auto sweep, trace average 100 traces, measurement corrected by Pwr correction factor
Note 6:	Emission has non constant duty cycle $< 98\%$, average measurement performed: RBW=1MHz, VBW $> 1/T$, peak detector, linear average mode, sweep time auto, max hold. Max hold for $50*(1/DC)$ traces
Note 7:	Emission has non constant duty cycle $< 98\%$, average measurement performed: RBW=1MHz, VBW $> 1/T$, RMS detector, sweep time auto, max hold. Max hold for $50*(1/DC)$ traces
Note 8:	Plots of the average and peak bandedge do not account for any duty cycle correction. Refer to the tabular results for final measurements.



EMC Test Data

Client: Pace Americas, Inc.	Job Number: JD100298
Model: Wi-Fi Module 2.4 GHz	T-Log Number: T100355
	Project Manager: Irene Radamacher
Contact: Mark Rieger	Project Coordinator: -
Standard: FCC Part 15.247	Class: N/A

Run #1: Radiated Bandedge Measurements

Date of Test: 2/2/2016 0:00
 Test Engineer: Eddie Mariscal
 Test Location: FT Chamber #7
 Config. Used: 1
 Config Change: None
 EUT Voltage: 120V/60Hz

Channel: 1 Mode: n20
 Tx Chain: 3Tx Data Rate: MCS0

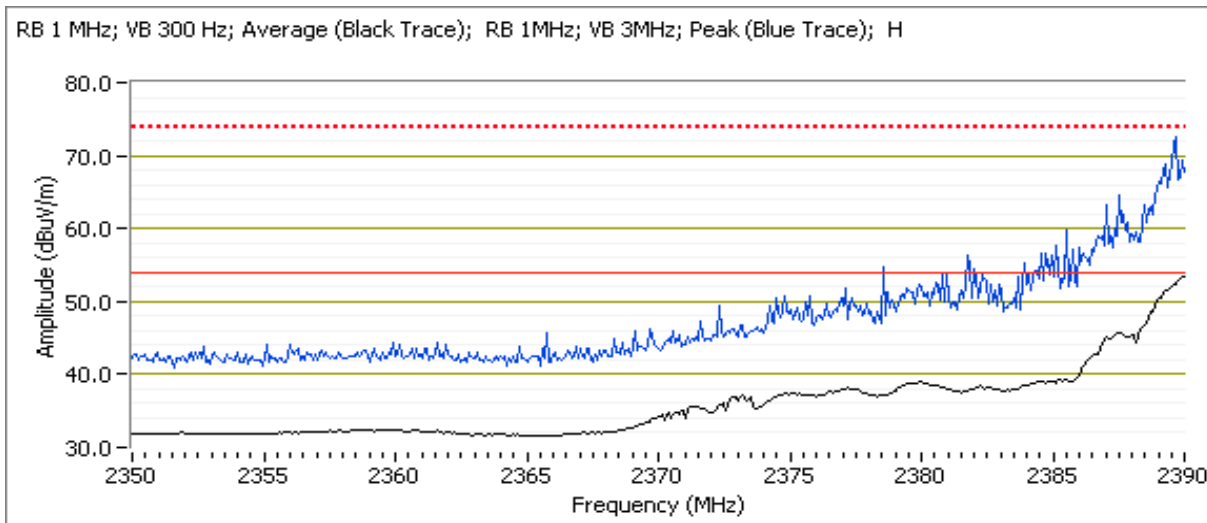

Band Edge Signal Field Strength - Direct measurement of field strength

Power Setting = 20

Frequency MHz	Level dB μ V/m	Pol v/h	15.209 / 15.247		Detector Pk/QP/Avg	Azimuth degrees	Height meters	Comments
			Limit	Margin				
2389.530	53.8	H	54.0	-0.2	AVG	351	1.8	POS; RB 1 MHz; VB: 300 Hz
2389.800	71.5	H	74.0	-2.5	PK	351	1.8	POS; RB 1 MHz; VB: 3 MHz
2389.970	52.3	V	54.0	-1.7	AVG	246	1.2	POS; RB 1 MHz; VB: 300 Hz
2389.850	73.5	V	74.0	-0.5	PK	246	1.2	POS; RB 1 MHz; VB: 3 MHz



EMC Test Data

Client: Pace Americas, Inc.	Job Number: JD100298
Model: Wi-Fi Module 2.4 GHz	T-Log Number: T100355
	Project Manager: Irene Radamacher
Contact: Mark Rieger	Project Coordinator: -
Standard: FCC Part 15.247	Class: N/A

Date of Test: 2/4/2016 0:00
 Test Engineer: Rafael Varelas
 Test Location: FT Chamber #7

Config. Used: 1
 Config Change: None
 EUT Voltage: 120V/60Hz

Channel: 2 Mode: n20
 Tx Chain: 3Tx Data Rate: MCS0

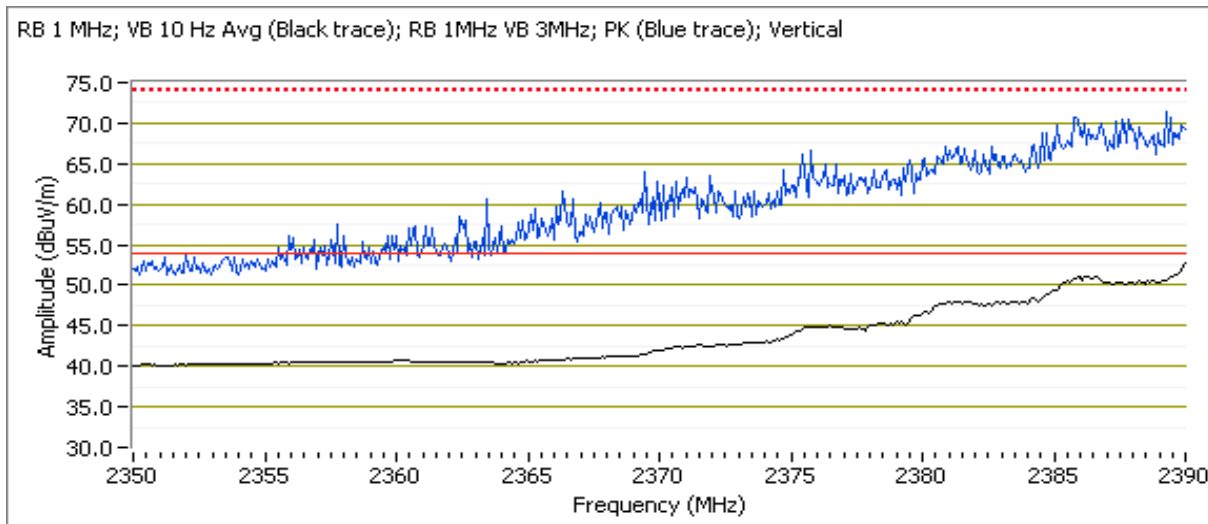

Band Edge Signal Field Strength - Direct measurement of field strength

Frequency	Level	Pol	15.209 / 15.247		Detector	Azimuth	Height	Comments
MHz	dBuV/m	v/h	Limit	Margin	Pk/QP/Avg	degrees	meters	
2385.730	73.4	V	74.0	-0.6	PK	283	1.3	POS; RB 1 MHz; VB: 3 MHz
2390.000	52.2	V	54.0	-1.8	Avg	283	1.3	Note 4,POS Vavg:100; RB 1 MHz; VB
2388.600	72.6	H	74.0	-1.4	PK	193	1.3	POS; RB 1 MHz; VB: 3 MHz
2388.480	52.2	H	54.0	-1.8	Avg	193	1.3	Note 4,POS Vavg:100; RB 1 MHz; VB



EMC Test Data

Client: Pace Americas, Inc.	Job Number: JD100298
Model: Wi-Fi Module 2.4 GHz	T-Log Number: T100355
Contact: Mark Rieger	Project Manager: Irene Radmacher
Standard: FCC Part 15.247	Project Coordinator: -
	Class: N/A

Channel: 11 Mode: n20
 Tx Chain: 3Tx Data Rate: MCS0

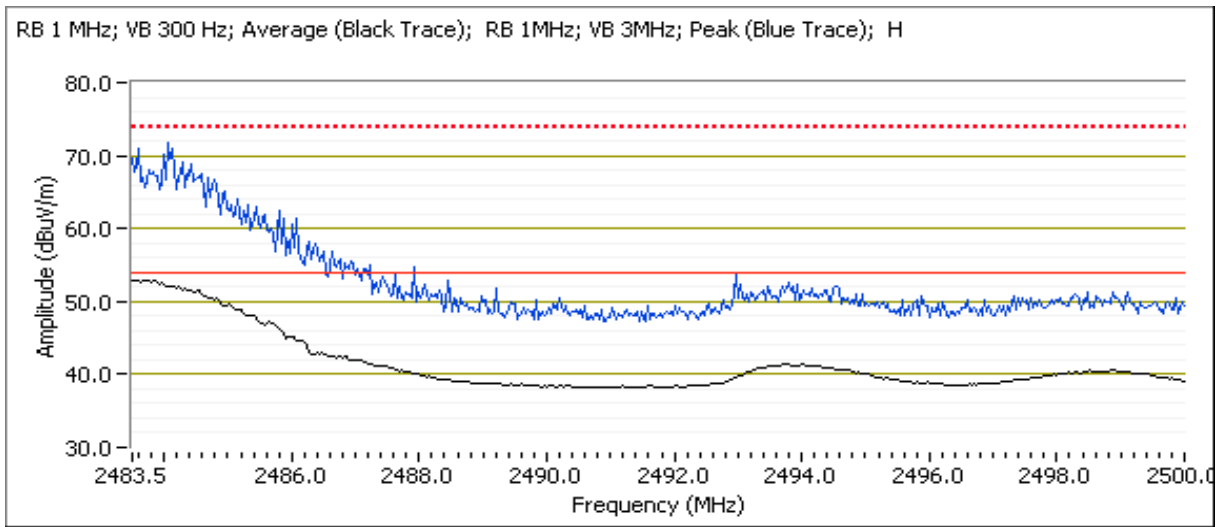

Band Edge Signal Field Strength - Direct measurement of field strength

Power Setting = 17.5								
Frequency	Level	Pol	15.209 / 15.247		Detector	Azimuth	Height	Comments
MHz	dB μ V/m	v/h	Limit	Margin	Pk/QP/Avg	degrees	meters	
2483.520	53.1	V	54.0	-0.9	AVG	291	1.0	POS; RB 1 MHz; VB: 300 Hz
2483.750	70.3	V	74.0	-3.7	PK	291	1.0	POS; RB 1 MHz; VB: 3 MHz
2483.610	53.1	H	54.0	-0.9	AVG	192	1.7	POS; RB 1 MHz; VB: 300 Hz
2484.870	70.0	H	74.0	-4.0	PK	192	1.7	POS; RB 1 MHz; VB: 3 MHz



EMC Test Data

Client: Pace Americas, Inc.	Job Number: JD100298
Model: Wi-Fi Module 2.4 GHz	T-Log Number: T100355
	Project Manager: Irene Radamacher
Contact: Mark Rieger	Project Coordinator: -
Standard: FCC Part 15.247	Class: N/A

Date of Test: 2/4/2016 0:00
 Test Engineer: Rafael Varelas
 Test Location: FT Chamber #7

Config. Used: 1
 Config Change: None
 EUT Voltage: 120V/60Hz

Channel: 10 Mode: n20
 Tx Chain: 3Tx Data Rate: MCS0

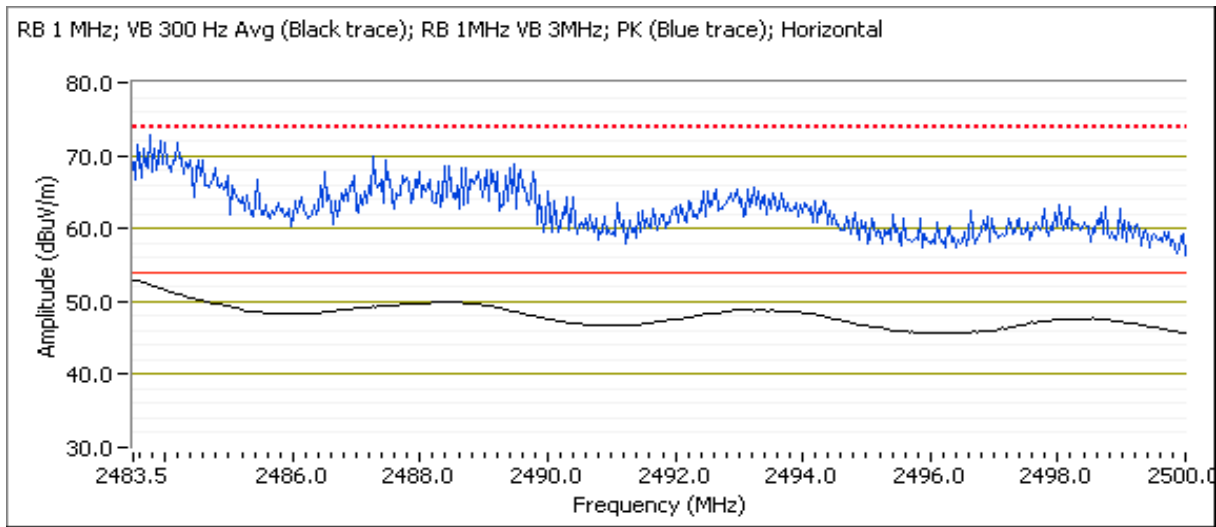

Band Edge Signal Field Strength - Direct measurement of field strength

Frequency MHz	Level dB μ V/m	Pol v/h	15.209 / 15.247		Detector Pk/QP/Avg	Azimuth degrees	Height meters	Comments
			Limit	Margin				
2483.630	73.2	H	74.0	-0.8	PK	189	1.1	POS; RB 1 MHz; VB: 3 MHz
2483.500	53.1	H	54.0	-0.9	Avg	189	1.1	Note 4, POS Vavg:100; RB 1 MHz; VB
2488.260	72.6	V	74.0	-1.4	PK	86	1.0	POS; RB 1 MHz; VB: 3 MHz
2483.500	50.9	V	54.0	-3.1	Avg	86	1.0	Note 4, POS Vavg:100; RB 1 MHz; VB



EMC Test Data

Client: Pace Americas, Inc.	Job Number: JD100298
Model: Wi-Fi Module 2.4 GHz	T-Log Number: T100355
	Project Manager: Irene Radamacher
Contact: Mark Rieger	Project Coordinator: -
Standard: FCC Part 15.247	Class: N/A

Run #2: Radiated Bandedge Measurements

Date of Test: 2/2/2016 0:00
 Test Engineer: Eddie Mariscal
 Test Location: FT Chamber #7
 Config. Used: 1
 Config Change: None
 EUT Voltage: 120V/60Hz

Channel: 3 Mode: n40
 Tx Chain: 3Tx Data Rate: MCS0

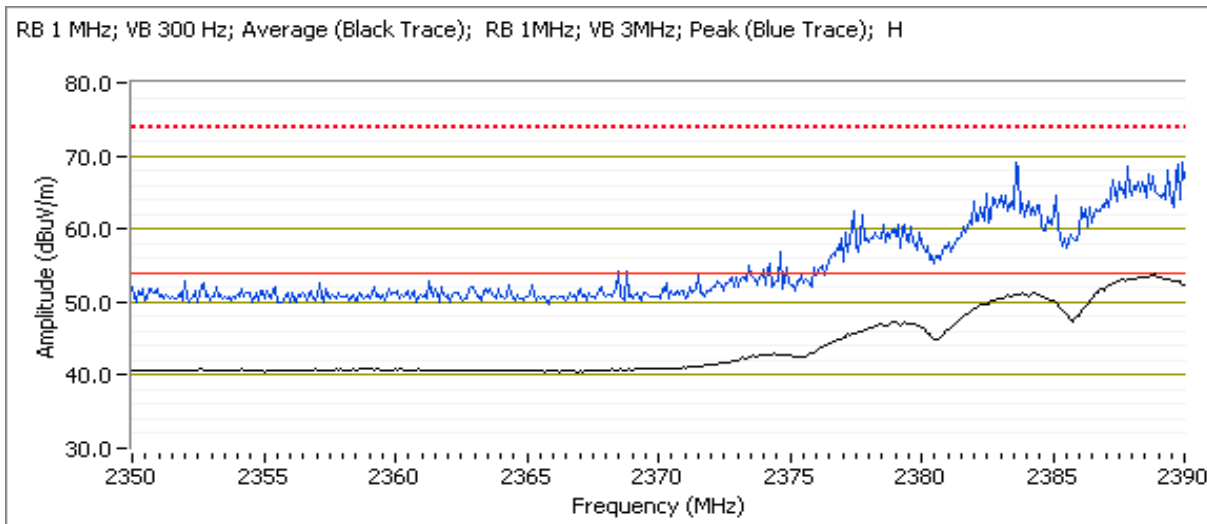

Band Edge Signal Field Strength - Direct measurement of field strength

Power Setting = 17.5

Frequency	Level	Pol	15.209 / 15.247		Detector	Azimuth	Height	Comments
MHz	dB μ V/m	v/h	Limit	Margin	Pk/QP/Avg	degrees	meters	
2389.000	53.9	H	54.0	-0.1	AVG	193	1.7	POS; RB 1 MHz; VB: 300 Hz
2389.690	70.1	H	74.0	-3.9	PK	193	1.7	POS; RB 1 MHz; VB: 3 MHz
2389.440	49.5	V	54.0	-4.5	AVG	248	1.2	POS; RB 1 MHz; VB: 300 Hz
2389.320	66.6	V	74.0	-7.4	PK	248	1.2	POS; RB 1 MHz; VB: 3 MHz



EMC Test Data

Client: Pace Americas, Inc.	Job Number: JD100298
Model: Wi-Fi Module 2.4 GHz	T-Log Number: T100355
Contact: Mark Rieger	Project Manager: Irene Radmacher
Standard: FCC Part 15.247	Project Coordinator: -
	Class: N/A

Channel: 6 Mode: n40
 Tx Chain: 3Tx Data Rate: MCS0

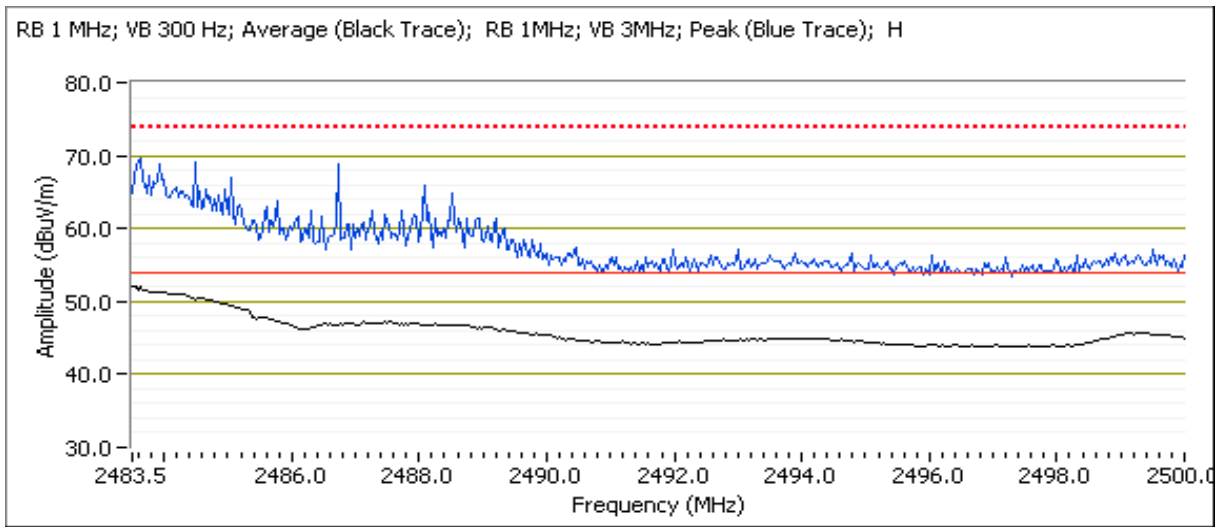

Band Edge Signal Field Strength - Direct measurement of field strength

Power Setting = 17.5

Frequency	Level	Pol	15.209 / 15.247		Detector	Azimuth	Height	Comments
MHz	dB μ V/m	v/h	Limit	Margin	Pk/QP/Avg	degrees	meters	
2483.500	51.6	H	54.0	-2.4	AVG	190	1.7	POS; RB 1 MHz; VB: 300 Hz
2484.420	66.9	H	74.0	-7.1	PK	190	1.7	POS; RB 1 MHz; VB: 3 MHz
2485.300	45.1	V	54.0	-8.9	AVG	293	2.2	POS; RB 1 MHz; VB: 300 Hz
2484.830	64.3	V	74.0	-9.7	PK	293	2.2	POS; RB 1 MHz; VB: 3 MHz



EMC Test Data

Client: Pace Americas, Inc.	Job Number: JD100298
Model: Wi-Fi Module 2.4 GHz	T-Log Number: T100355
Contact: Mark Rieger	Project Manager: Irene Radamacher
Standard: FCC Part 15.247	Project Coordinator: -
	Class: N/A

Channel: 7 Mode: n40
 Tx Chain: 3Tx Data Rate: MCS0

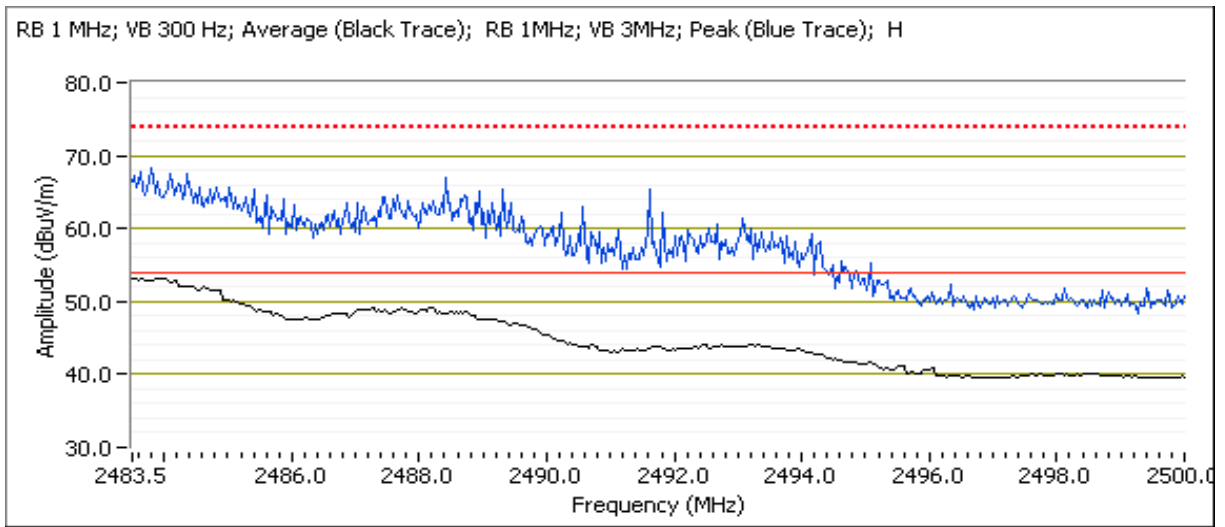

Band Edge Signal Field Strength - Direct measurement of field strength

Power Setting = 15.5

Frequency	Level	Pol	15.209 / 15.247		Detector	Azimuth	Height	Comments
MHz	dB μ V/m	v/h	Limit	Margin	Pk/QP/Avg	degrees	meters	
2483.700	51.2	H	54.0	-2.8	AVG	190	1.3	POS; RB 1 MHz; VB: 300 Hz
2484.100	68.1	H	74.0	-5.9	PK	190	1.3	POS; RB 1 MHz; VB: 3 MHz
2485.440	48.8	V	54.0	-5.2	AVG	290	1.8	POS; RB 1 MHz; VB: 1 kHz
2485.490	65.4	V	74.0	-8.6	PK	290	1.8	POS; RB 1 MHz; VB: 3 MHz



EMC Test Data

Client: Pace Americas, Inc.	Job Number: JD100298
Model: Wi-Fi Module 2.4 GHz	T-Log Number: T100355
Contact: Mark Rieger	Project Manager: Irene Radamacher
Standard: FCC Part 15.247	Project Coordinator: -
	Class: N/A

Channel: 8 Mode: n40
 Tx Chain: 3Tx Data Rate: MCS0

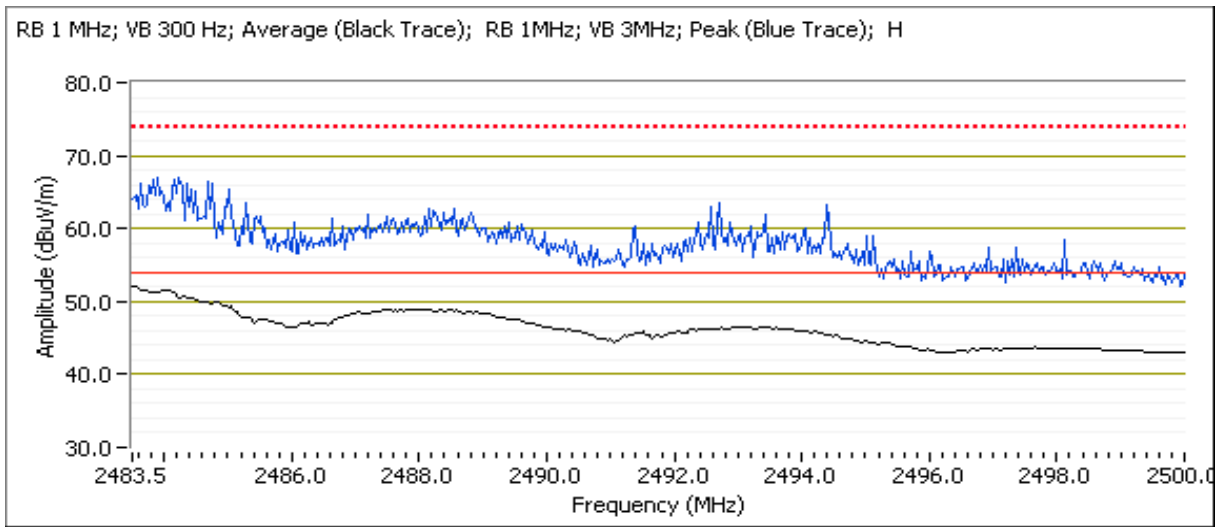

Band Edge Signal Field Strength - Direct measurement of field strength

Power Setting = 14.5

Frequency	Level	Pol	15.209 / 15.247		Detector	Azimuth	Height	Comments
MHz	dB μ V/m	v/h	Limit	Margin	Pk/QP/Avg	degrees	meters	
2483.540	51.9	H	54.0	-2.1	AVG	187	1.5	POS; RB 1 MHz; VB: 300 Hz
2483.650	67.2	H	74.0	-6.8	PK	187	1.5	POS; RB 1 MHz; VB: 3 MHz
2485.680	45.2	V	54.0	-8.8	AVG	299	1.9	POS; RB 1 MHz; VB: 300 Hz
2487.030	59.8	V	74.0	-14.2	PK	299	1.9	POS; RB 1 MHz; VB: 3 MHz



EMC Test Data

Client: Pace Americas, Inc.	Job Number: JD100298
Model: Wi-Fi Module 2.4 GHz	T-Log Number: T100355
	Project Manager: Irene Radamacher
Contact: Mark Rieger	Project Coordinator: -
Standard: FCC Part 15.247	Class: N/A

Channel: 9 Mode: n40
 Tx Chain: 3Tx Data Rate: MCS0

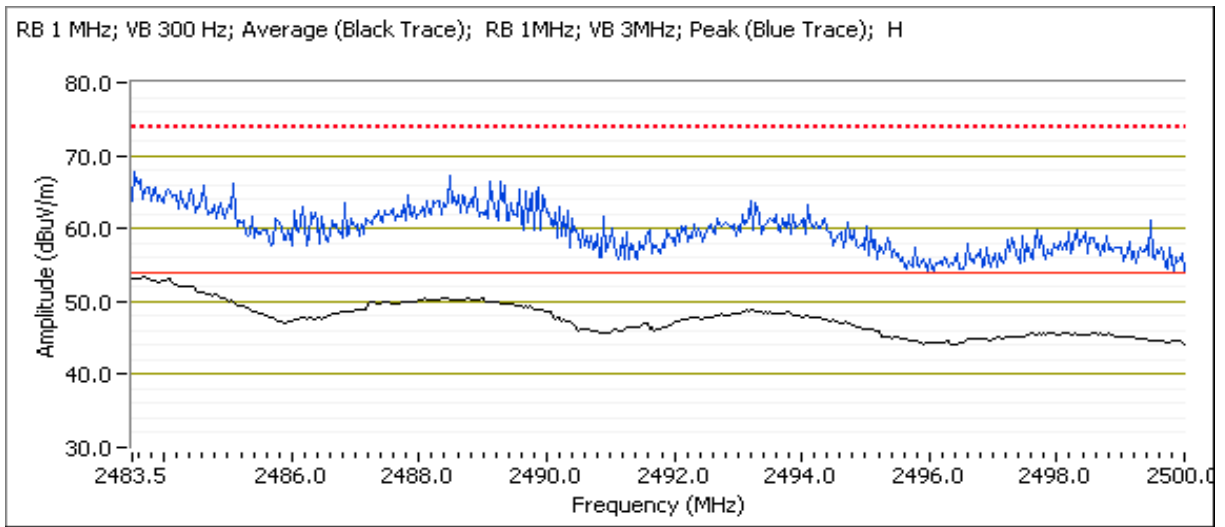

Band Edge Signal Field Strength - Direct measurement of field strength

Power Setting = 14.5

Frequency	Level	Pol	15.209 / 15.247		Detector	Azimuth	Height	Comments
MHz	dB μ V/m	v/h	Limit	Margin	Pk/QP/Avg	degrees	meters	
2483.800	53.2	H	54.0	-0.8	AVG	189	1.5	POS; RB 1 MHz; VB: 300 Hz
2483.790	68.2	H	74.0	-5.8	PK	189	1.5	POS; RB 1 MHz; VB: 3 MHz
2485.630	47.7	V	54.0	-6.3	AVG	301	1.8	POS; RB 1 MHz; VB: 300 Hz
2484.600	70.1	V	74.0	-3.9	PK	301	1.8	POS; RB 1 MHz; VB: 3 MHz



EMC Test Data

Client:	Pace Americas, Inc.	Job Number:	JD100298
Model:	Wi-Fi Module 2.4 GHz	T-Log Number:	T100355
		Project Manager:	Irene Radmacher
Contact:	Mark Rieger	Project Coordinator:	-
Standard:	FCC Part 15.247	Class:	N/A

RSS-247 and FCC 15.247 (DTS) Radiated Spurious Emissions

Test Specific Details

Objective: The objective of this test session is to perform final qualification testing of the EUT with respect to the specification listed above.

General Test Configuration

The EUT and all local support equipment were located on the turntable for radiated spurious emissions testing. For radiated emissions testing the measurement antenna was located 3 meters from the EUT, unless otherwise noted.

Ambient Conditions:

Temperature: 20 °C
Rel. Humidity: 32 %

Modifications Made During Testing

No modifications were made to the EUT during testing

Deviations From The Standard

No deviations were made from the requirements of the standard.



EMC Test Data

Client: Pace Americas, Inc.	Job Number: JD100298
Model: Wi-Fi Module 2.4 GHz	T-Log Number: T100355
	Project Manager: Irene Radamacher
Contact: Mark Rieger	Project Coordinator: -
Standard: FCC Part 15.247	Class: N/A

Summary of Results - Device Operating in the 2400-2483.5 MHz Band

Run #	Mode	Channel	Target Power	Power Setting	Test Performed	Limit	Result / Margin
1	b	1 - 2412MHz	26	25.5	Restricted Band Edge (2390 MHz)	FCC Part 15.209 / 15.247(c)	49.8 dBµV/m @ 2387.1 MHz (-4.2 dB)
	b	11 - 2462MHz	26	25.5	Restricted Band Edge (2483.5 MHz)	FCC Part 15.209 / 15.247(c)	51.3 dBµV/m @ 2486.7 MHz (-2.7 dB)
2	g	1 - 2412MHz	24.5	20.5	Restricted Band Edge (2390 MHz)	FCC Part 15.209 / 15.247(c)	72.2 dBµV/m @ 2389.9 MHz (-1.8 dB)
	g	2 - 2417MHz	24.5	24.5	Restricted Band Edge (2390 MHz)	FCC Part 15.209 / 15.247(c)	73.3 dBµV/m @ 2388.6 MHz (-0.7 dB)
	g	9 - 2452MHz	27.0	25.5	Restricted Band Edge (2483.5 MHz)	FCC Part 15.209 / 15.247(c)	73.6 dBµV/m @ 2483.6 MHz (-0.4 dB)
	g	10 - 2457MHz	24.5	23.5	Restricted Band Edge (2483.5 MHz)	FCC Part 15.209 / 15.247(c)	70.7 dBµV/m @ 2487.7 MHz (-3.3 dB)
	g	11 - 2462MHz	24.5	19.5	Restricted Band Edge (2483.5 MHz)	FCC Part 15.209 / 15.247(c)	72.5 dBµV/m @ 2484.2 MHz (-1.5 dB)
3	n20	1 - 2412MHz	24.5	19.5	Restricted Band Edge (2390 MHz)	FCC Part 15.209 / 15.247(c)	71.9 dBµV/m @ 2389.6 MHz (-2.1 dB)
	n20	2 - 2417MHz	24.5	23.5	Restricted Band Edge (2390 MHz)	FCC Part 15.209 / 15.247(c)	73.5 dBµV/m @ 2386.9 MHz (-0.5 dB)
	n20	10 - 2457MHz	24.5	22.5	Restricted Band Edge (2483.5 MHz)	FCC Part 15.209 / 15.247(c)	71.2 dBµV/m @ 2484.1 MHz (-2.8 dB)
	n20	11 - 2462MHz	24.5	18.5	Restricted Band Edge (2483.5 MHz)	FCC Part 15.209 / 15.247(c)	73.1 dBµV/m @ 2484.1 MHz (-0.9 dB)
4	n40	3 - 2422MHz	24.5	19.5	Restricted Band Edge (2390 MHz)	FCC Part 15.209 / 15.247(c)	52.7 dBµV/m @ 2389.7 MHz (-1.3 dB)
	n40	4 - 2427MHz	24.5	20.5	Restricted Band Edge (2390 MHz)	FCC Part 15.209 / 15.247(c)	72.3 dBµV/m @ 2389.1 MHz (-1.7 dB)
	n40	5 - 2432MHz	24.5	22.5	Restricted Band Edge (2390 MHz)	FCC Part 15.209 / 15.247(c)	52.6 dBµV/m @ 2390.0 MHz (-1.4 dB)
	n40	6 - 2437MHz	24.5	18.0	Restricted Band Edge (2483.5 MHz)	FCC Part 15.209 / 15.247(c)	52.7 dBµV/m @ 2483.7 MHz (-1.3 dB)
	n40	7 - 2442MHz	24.5	16.5	Restricted Band Edge (2483.5 MHz)	FCC Part 15.209 / 15.247(c)	52.6 dBµV/m @ 2484.3 MHz (-1.4 dB)
	n40	8 - 2447MHz	24.5	15.5	Restricted Band Edge (2483.5 MHz)	FCC Part 15.209 / 15.247(c)	53.8 dBµV/m @ 2484.2 MHz (-0.2 dB)
	n40	9 - 2452MHz	24.5	14.5	Restricted Band Edge (2483.5 MHz)	FCC Part 15.209 / 15.247(c)	53.3 dBµV/m @ 2483.8 MHz (-0.7 dB)



EMC Test Data

Client:	Pace Americas, Inc.	Job Number:	JD100298
Model:	Wi-Fi Module 2.4 GHz	T-Log Number:	T100355
		Project Manager:	Irene Radamacher
Contact:	Mark Rieger	Project Coordinator:	-
Standard:	FCC Part 15.247	Class:	N/A

Sample Notes

Sample S/N: F55154470184
 Driver: 7.14.89.21.571.206
 Antenna: 3 Tx (Non beamforming modes)

Procedure Comments:

Measurements performed in accordance with FCC KDB 558074
 Peak measurements performed with: RBW=1MHz, VBW=3MHz, peak detector, max hold, auto sweep time
 Unless otherwise stated/noted, emission has a duty cycle $\geq 98\%$ and was measured using RBW=1MHz, VBW=10Hz, peak detector, linear average mode, auto sweep time, max hold.

Mode	Data Rate	Duty Cycle (x)	Constant DC?	T (ms)	Pwr Cor Factor*	Lin Volt Cor Factor**	Min VBW for FS (Hz)
11b	2 Mb/s	100.0%	Yes	10.0	0.0	0.0	10
11g	6 Mb/s	98.5%	Yes	2.16	0.0	0.0	10
n20	MCS 0	98.5%	Yes	2.02	0.0	0.0	10
n40	MCS 0	90.4%	Yes	1.25	0.4	0.9	801

Measurement Specific Notes:

Note 1:	Emission in non-restricted band, but limit of 15.209 used.
Note 2:	Emission in non-restricted band, the limit was set 30dB below the level of the fundamental and measured in 100kHz.
Note 4:	Emission has constant duty cycle $< 98\%$, average measurement performed: RBW=1MHz, VBW=3MHz, RMS, Power averaging, auto sweep, trace average 100 traces, measurement corrected by Pwr correction factor
Note 8:	Plots of the average and peak bandedge do not account for any duty cycle correction. Refer to the tabular results for final measurements.



EMC Test Data

Client: Pace Americas, Inc.	Job Number: JD100298
Model: Wi-Fi Module 2.4 GHz	T-Log Number: T100355
	Project Manager: Irene Radamacher
Contact: Mark Rieger	Project Coordinator: -
Standard: FCC Part 15.247	Class: N/A

Run #1: Radiated Bandedge Measurements

Date of Test: 01/05/16
 Test Engineer: Eddie Mariscal
 Test Location: FT Chamber#7
 Config. Used: 1
 Config Change: none
 EUT Voltage: 120V/60Hz

Channel: 1 Mode: b Target Power Setting: 26
 Tx Chain: 3x3 Data Rate: 2 Mb/s Passing Power Setting: 25.5

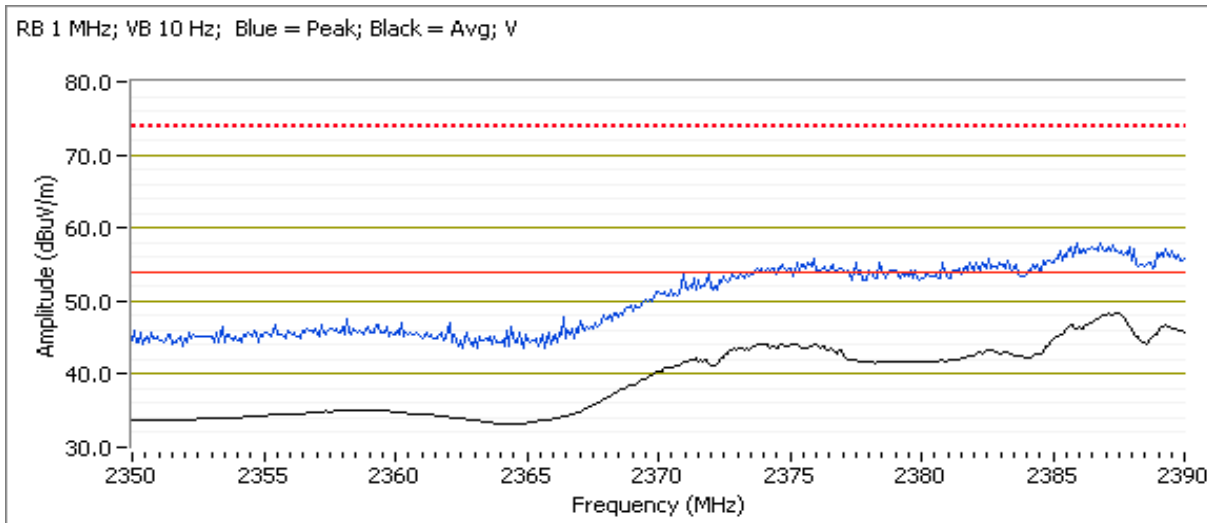

Band Edge Signal Field Strength - Direct measurement of field strength

Power Setting = 25.5

Frequency	Level	Pol	15.209 / 15.247		Detector	Azimuth	Height	Comments
MHz	dB μ V/m	v/h	Limit	Margin	Pk/QP/Avg	degrees	meters	
2387.060	49.8	V	54.0	-4.2	AVG	270	1.0	POS; RB 1 MHz; VB: 10 Hz
2387.050	60.2	V	74.0	-13.8	PK	270	1.0	POS; RB 1 MHz; VB: 3 MHz
2389.590	52.3	H	54.0	-1.7	AVG	249	2.0	POS; RB 1 MHz; VB: 10 Hz
2389.850	59.9	H	74.0	-14.1	PK	249	2.0	POS; RB 1 MHz; VB: 3 MHz



EMC Test Data

Client: Pace Americas, Inc.	Job Number: JD100298
Model: Wi-Fi Module 2.4 GHz	T-Log Number: T100355
Contact: Mark Rieger	Project Manager: Irene Radamacher
Standard: FCC Part 15.247	Project Coordinator: -
	Class: N/A

Channel: 11 Mode: b Target Power Setting: 26
 Tx Chain: 3x3 Data Rate: 2 Mb/s Passing Power Setting: 25.5

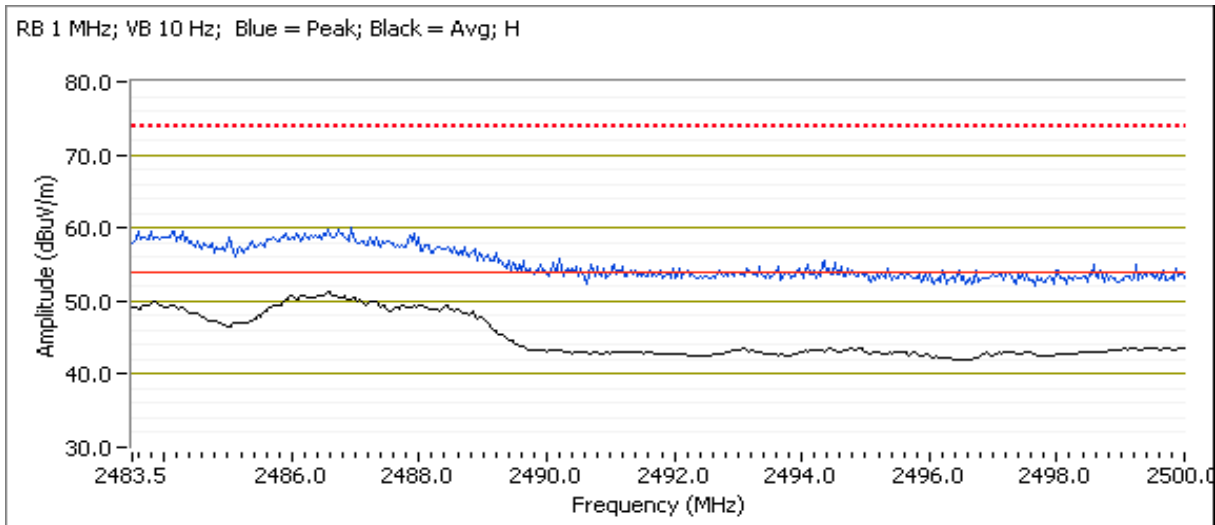

Band Edge Signal Field Strength - Direct measurement of field strength

Power Setting = 25.5

Frequency	Level	Pol	15.209 / 15.247		Detector	Azimuth	Height	Comments
MHz	dB μ V/m	v/h	Limit	Margin	Pk/QP/Avg	degrees	meters	
2486.670	51.3	H	54.0	-2.7	AVG	4	1.0	POS; RB 1 MHz; VB: 10 Hz
2486.990	60.4	H	74.0	-13.6	PK	4	1.0	POS; RB 1 MHz; VB: 3 MHz
2483.520	53.9	V	54.0	-0.1	AVG	191	1.9	POS; RB 1 MHz; VB: 10 Hz
2483.940	62.2	V	74.0	-11.8	PK	191	1.9	POS; RB 1 MHz; VB: 3 MHz



EMC Test Data

Client: Pace Americas, Inc.	Job Number: JD100298
Model: Wi-Fi Module 2.4 GHz	T-Log Number: T100355
	Project Manager: Irene Radamacher
Contact: Mark Rieger	Project Coordinator: -
Standard: FCC Part 15.247	Class: N/A

Run #2: Radiated Bandedge Measurements

Date of Test: 01/05/16
 Test Engineer: Eddie Mariscal
 Test Location: FT Chamber#7
 Config. Used: 1
 Config Change: none
 EUT Voltage: 120V/60Hz

Channel: 1 Mode: g Target Power Setting: 24.5
 Tx Chain: 3x3 Data Rate: 6 Mb/s Passing Power Setting: 20.5

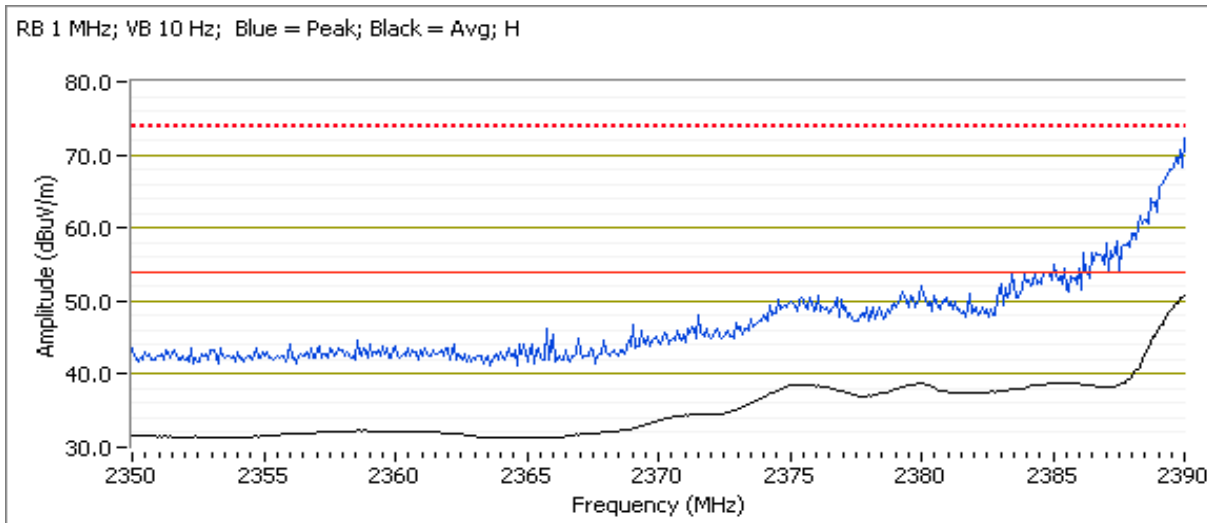

Band Edge Signal Field Strength - Direct measurement of field strength

Power Setting = 20.5

Frequency	Level	Pol	15.209 / 15.247		Detector	Azimuth	Height	Comments
MHz	dB μ V/m	v/h	Limit	Margin	Pk/QP/Avg	degrees	meters	
2389.990	50.1	H	54.0	-3.9	AVG	192	1.9	POS; RB 1 MHz; VB: 10 Hz
2389.920	72.2	H	74.0	-1.8	PK	192	1.9	POS; RB 1 MHz; VB: 3 MHz

Client: Pace Americas, Inc.	Job Number: JD100298
Model: Wi-Fi Module 2.4 GHz	T-Log Number: T100355
	Project Manager: Irene Radamacher
Contact: Mark Rieger	Project Coordinator: -
Standard: FCC Part 15.247	Class: N/A

Date of Test: 01/05/16
 Test Engineer: Mehran Birgani
 Test Location: FT Chamber#7

Config. Used: 1
 Config Change: none
 EUT Voltage: 120V/60Hz

Channel: 2 Mode: g Target Power Setting: 24.5
 Tx Chain: 3x3 Data Rate: 6 Mb/s Passing Power Setting: 24.5

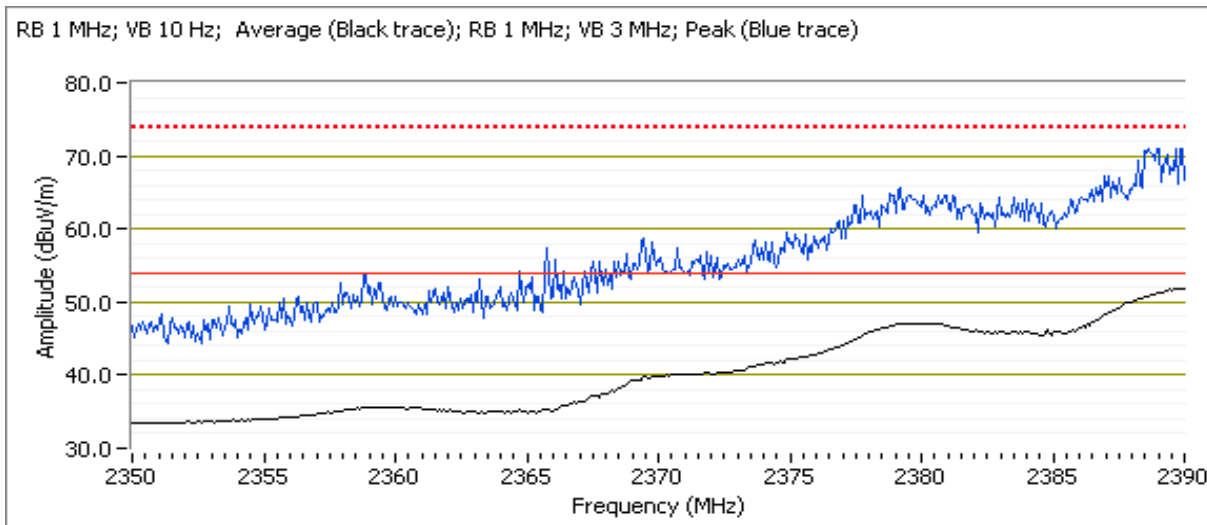

Band Edge Signal Field Strength - Direct measurement of field strength

Frequency	Level	Pol	15.209 / 15.247		Detector	Azimuth	Height	Comments
MHz	dB μ V/m	v/h	Limit	Margin	Pk/QP/Avg	degrees	meters	
2388.620	73.3	V	74.0	-0.7	PK	312	1.0	POS; RB 1 MHz; VB: 3 MHz
2389.810	53.1	V	54.0	-0.9	AVG	312	1.0	POS; RB 1 MHz; VB: 10 Hz
2389.380	69.2	H	74.0	-4.8	PK	180	1.0	POS; RB 1 MHz; VB: 3 MHz
2389.980	48.9	H	54.0	-5.1	AVG	180	1.0	POS; RB 1 MHz; VB: 10 Hz



EMC Test Data

Client: Pace Americas, Inc.	Job Number: JD100298
Model: Wi-Fi Module 2.4 GHz	T-Log Number: T100355
	Project Manager: Irene Radamacher
Contact: Mark Rieger	Project Coordinator: -
Standard: FCC Part 15.247	Class: N/A

Date of Test: 01/05/16
 Test Engineer: Rafael Varelas
 Test Location: FT Chamber#7

Config. Used: 1
 Config Change: none
 EUT Voltage: 120V/60Hz

Channel: 9 Mode: g Target Power Setting: 27.0
 Tx Chain: 3x3 Data Rate: 6 Mb/s Passing Power Setting: 25.5

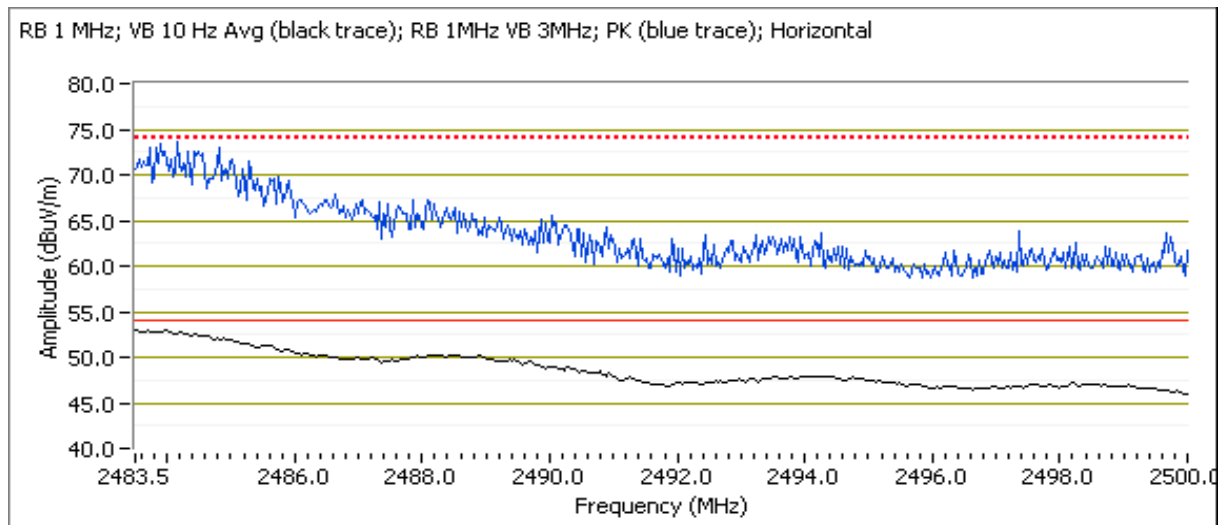

Band Edge Signal Field Strength - Direct measurement of field strength

Frequency MHz	Level dB μ V/m	Pol v/h	15.209 / 15.247		Detector Pk/QP/Avg	Azimuth degrees	Height meters	Comments
			Limit	Margin				
2483.630	73.6	H	74.0	-0.4	PK	190	1.2	POS; RB 1 MHz; VB: 3 MHz
2483.930	53.2	H	54.0	-0.8	AVG	190	1.2	POS; RB 1 MHz; VB: 10 Hz
2484.760	72.5	V	74.0	-1.5	PK	325	1.0	POS; RB 1 MHz; VB: 3 MHz
2483.600	52.2	V	54.0	-1.8	AVG	325	1.0	POS; RB 1 MHz; VB: 10 Hz



EMC Test Data

Client: Pace Americas, Inc.	Job Number: JD100298
Model: Wi-Fi Module 2.4 GHz	T-Log Number: T100355
	Project Manager: Irene Radamacher
Contact: Mark Rieger	Project Coordinator: -
Standard: FCC Part 15.247	Class: N/A

Date of Test: 01/05/16
 Test Engineer: Mehran Birgani
 Test Location: FT Chamber#7

Config. Used: 1
 Config Change: none
 EUT Voltage: 120V/60Hz

Channel: 10 Mode: g Target Power Setting: 24.5
 Tx Chain: 3x3 Data Rate: 6 Mb/s Passing Power Setting: 23.5

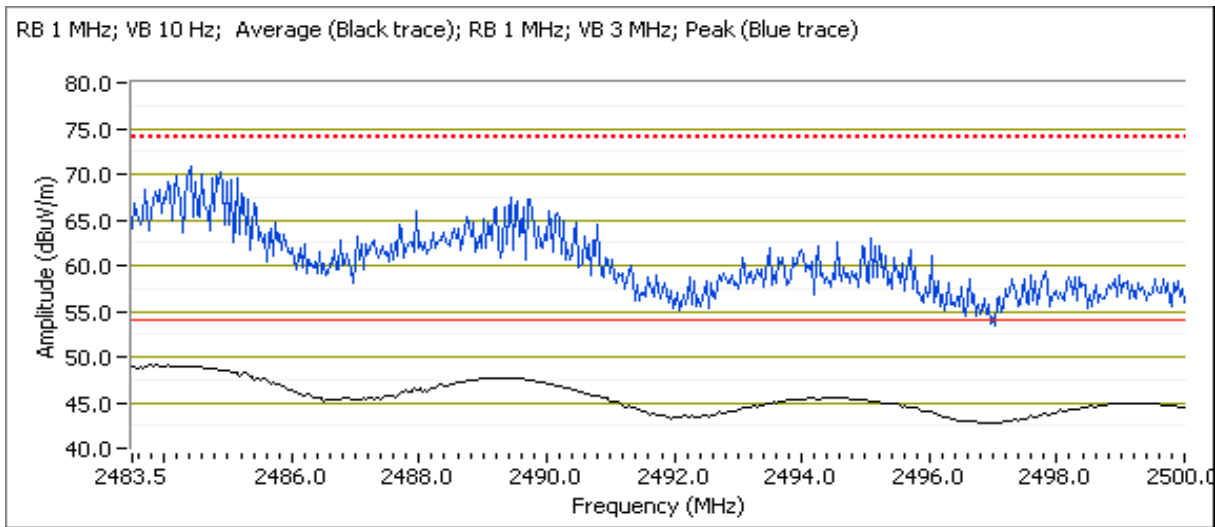

Band Edge Signal Field Strength - Direct measurement of field strength

Power Setting = 23.5

Frequency	Level	Pol	15.209 / 15.247		Detector	Azimuth	Height	Comments
MHz	dB μ V/m	v/h	Limit	Margin	Pk/QP/Avg	degrees	meters	
2487.690	70.7	V	74.0	-3.3	PK	282	1.4	POS; RB 1 MHz; VB: 3 MHz
2483.520	50.3	H	54.0	-3.7	AVG	187	1.4	POS; RB 1 MHz; VB: 10 Hz
2485.140	70.1	H	74.0	-3.9	PK	187	1.4	POS; RB 1 MHz; VB: 3 MHz
2485.200	48.6	V	54.0	-5.4	AVG	282	1.4	POS; RB 1 MHz; VB: 10 Hz



EMC Test Data

Client: Pace Americas, Inc.	Job Number: JD100298
Model: Wi-Fi Module 2.4 GHz	T-Log Number: T100355
	Project Manager: Irene Radamacher
Contact: Mark Rieger	Project Coordinator: -
Standard: FCC Part 15.247	Class: N/A

Date of Test: 01/05/16
 Test Engineer: Mehran Birgani
 Test Location: FT Chamber#7

Config. Used: 1
 Config Change: none
 EUT Voltage: 120V/60Hz

Channel: 11 Mode: g Target Power Setting: 24.5
 Tx Chain: 3x3 Data Rate: 6 Mb/s Passing Power Setting: 19.5

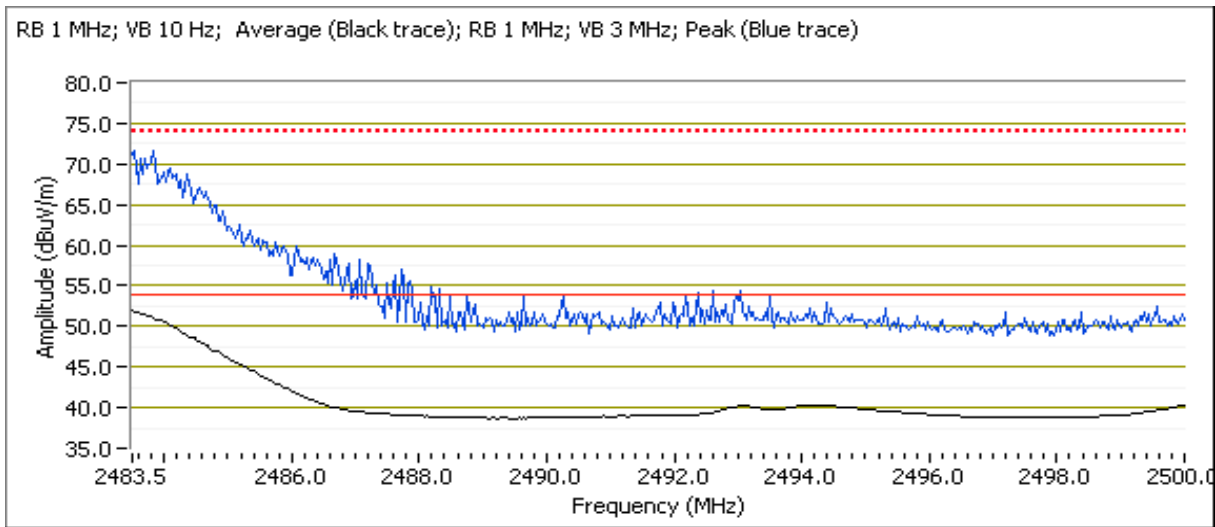

Band Edge Signal Field Strength - Direct measurement of field strength

Power Setting = 19.5

Frequency	Level	Pol	15.209 / 15.247		Detector	Azimuth	Height	Comments
MHz	dB μ V/m	v/h	Limit	Margin	Pk/QP/Avg	degrees	meters	
2484.220	72.5	H	74.0	-1.5	PK	187	1.4	POS; RB 1 MHz; VB: 3 MHz
2483.730	51.7	H	54.0	-2.3	AVG	187	1.4	POS; RB 1 MHz; VB: 10 Hz
2483.510	51.2	V	54.0	-2.8	AVG	285	1.9	POS; RB 1 MHz; VB: 10 Hz
2484.040	70.7	V	74.0	-3.3	PK	285	1.9	POS; RB 1 MHz; VB: 3 MHz



EMC Test Data

Client: Pace Americas, Inc.	Job Number: JD100298
Model: Wi-Fi Module 2.4 GHz	T-Log Number: T100355
Contact: Mark Rieger	Project Manager: Irene Radamacher
Standard: FCC Part 15.247	Project Coordinator: -
	Class: N/A

Run #3: Radiated Bandedge Measurements

Date of Test: 01/05/16
 Test Engineer: Mehran Birgani
 Test Location: FT Chamber#7
 Config. Used: 1
 Config Change: none
 EUT Voltage: 120V/60Hz

Channel: 1 Mode: n20 Target Power Setting: 24.5
 Tx Chain: 3x3 Data Rate: MCS 0 Passing Power Setting: 19.5

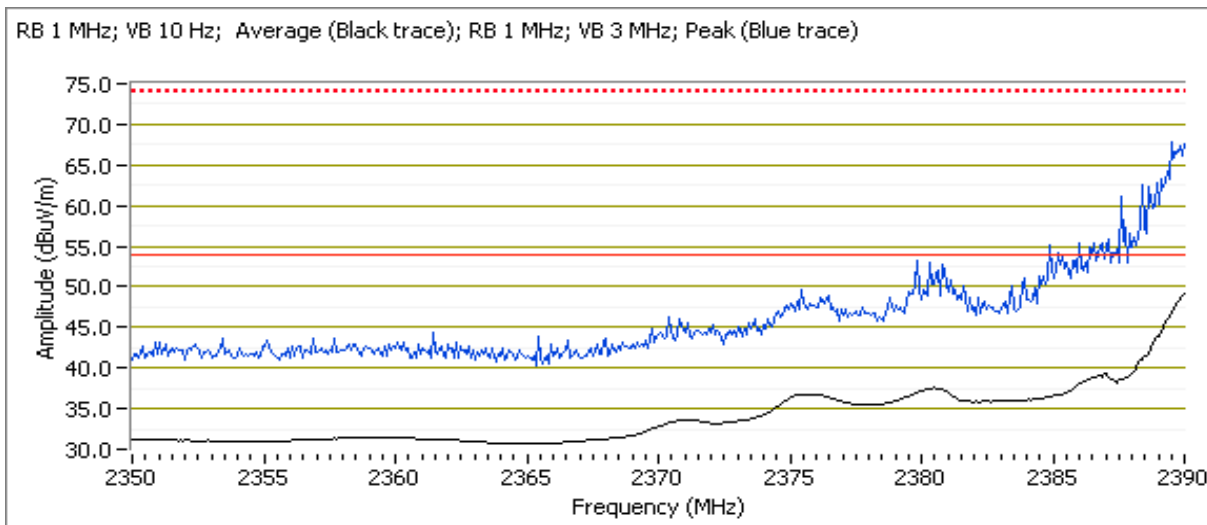

Band Edge Signal Field Strength - Direct measurement of field strength

Power Setting = 19.5

Frequency MHz	Level dB μ V/m	Pol v/h	15.209 / 15.247		Detector Pk/QP/Avg	Azimuth degrees	Height meters	Comments
			Limit	Margin				
2389.580	71.9	H	74.0	-2.1	PK	186	1.9	POS; RB 1 MHz; VB: 3 MHz
2390.000	50.9	V	54.0	-3.1	AVG	324	1.3	POS; RB 1 MHz; VB: 10 Hz
2389.850	70.1	V	74.0	-3.9	PK	324	1.3	POS; RB 1 MHz; VB: 3 MHz
2390.000	49.9	H	54.0	-4.1	AVG	186	1.9	POS; RB 1 MHz; VB: 10 Hz



EMC Test Data

Client: Pace Americas, Inc.	Job Number: JD100298
Model: Wi-Fi Module 2.4 GHz	T-Log Number: T100355
	Project Manager: Irene Radamacher
Contact: Mark Rieger	Project Coordinator: -
Standard: FCC Part 15.247	Class: N/A

Date of Test: 01/05/16
 Test Engineer: Mehran Birgani
 Test Location: FT Chamber#7

Config. Used: 1
 Config Change: none
 EUT Voltage: 120V/60Hz

Channel: 2 Mode: n20 Target Power Setting: 24.5
 Tx Chain: 3x3 Data Rate: MCS 0 Passing Power Setting: 23.5

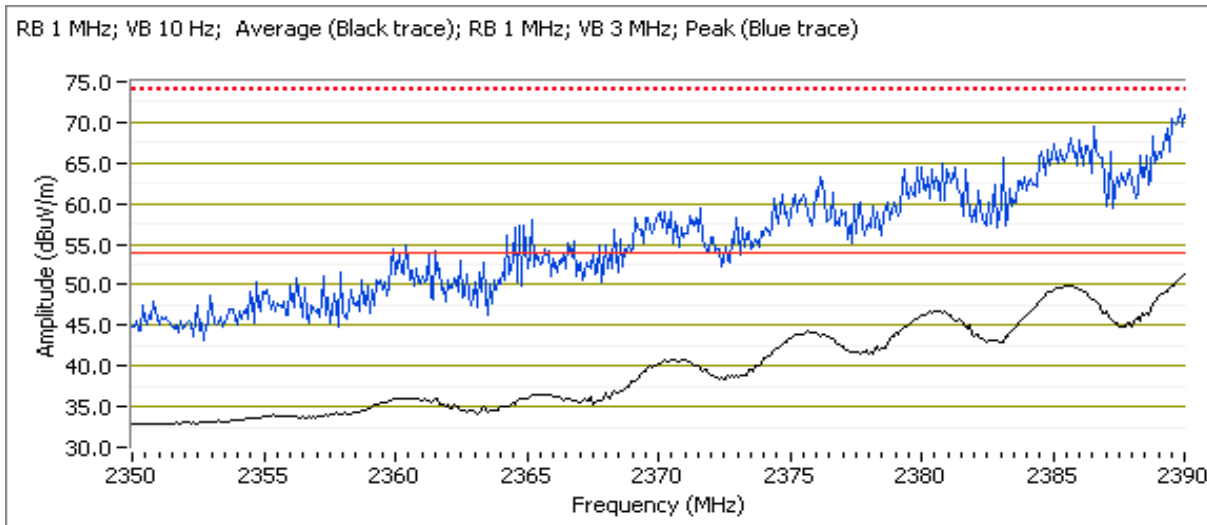

Band Edge Signal Field Strength - Direct measurement of field strength

Power Setting = 23.5

Frequency	Level	Pol	15.209 / 15.247		Detector	Azimuth	Height	Comments
MHz	dBuV/m	v/h	Limit	Margin	Pk/QP/Avg	degrees	meters	
2386.870	73.5	V	74.0	-0.5	PK	307	1.9	POS; RB 1 MHz; VB: 3 MHz
2389.280	72.9	H	74.0	-1.1	PK	192	1.9	POS; RB 1 MHz; VB: 3 MHz
2386.930	51.8	V	54.0	-2.2	AVG	307	1.9	POS; RB 1 MHz; VB: 10 Hz
2389.990	51.5	H	54.0	-2.5	AVG	192	1.9	POS; RB 1 MHz; VB: 10 Hz



EMC Test Data

Client: Pace Americas, Inc.	Job Number: JD100298
Model: Wi-Fi Module 2.4 GHz	T-Log Number: T100355
	Project Manager: Irene Radamacher
Contact: Mark Rieger	Project Coordinator: -
Standard: FCC Part 15.247	Class: N/A

Date of Test: 01/06/16 Config. Used: 1
 Test Engineer: Eddie Mariscal Config Change: none
 Test Location: FT Chamber#7 EUT Voltage: 120V/60Hz

Channel: 10 Mode: n20 Target Power Setting: 24.5
 Tx Chain: 3x3 Data Rate: MCS 0 Passing Power Setting: 22.5

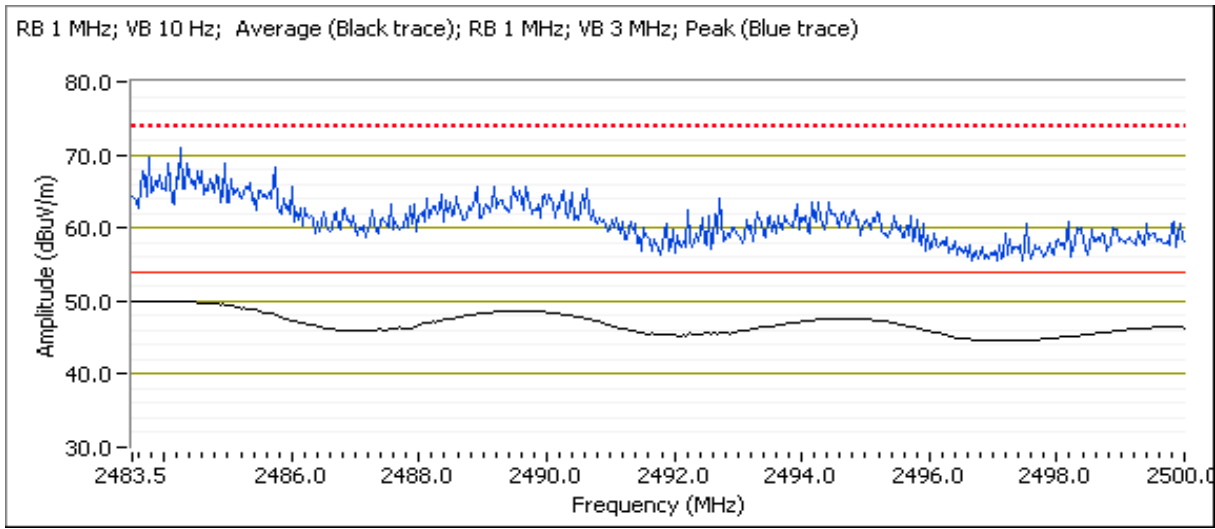

Band Edge Signal Field Strength - Direct measurement of field strength

Power Setting = 22.5

Frequency	Level	Pol	15.209 / 15.247		Detector	Azimuth	Height	Comments
MHz	dBuV/m	v/h	Limit	Margin	Pk/QP/Avg	degrees	meters	
2484.200	49.9	H	54.0	-4.1	AVG	189	1.8	POS; RB 1 MHz; VB: 10 Hz
2484.120	71.2	H	74.0	-2.8	PK	189	1.8	POS; RB 1 MHz; VB: 3 MHz



EMC Test Data

Client: Pace Americas, Inc.	Job Number: JD100298
Model: Wi-Fi Module 2.4 GHz	T-Log Number: T100355
	Project Manager: Irene Radamacher
Contact: Mark Rieger	Project Coordinator: -
Standard: FCC Part 15.247	Class: N/A

Date of Test: 01/06/16 Config. Used: 1
 Test Engineer: Eddie Mariscal Config Change: none
 Test Location: FT Chamber#7 EUT Voltage: 120V/60Hz

Channel: 11 Mode: n20 Target Power Setting: 24.5
 Tx Chain: 3x3 Data Rate: MCS 0 Passing Power Setting: 18.5

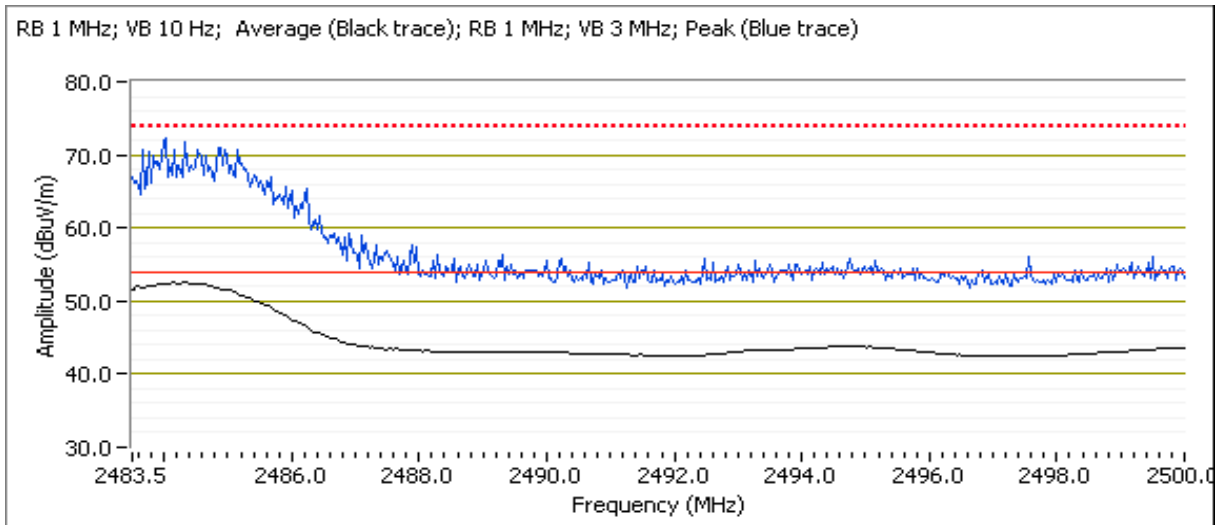

Band Edge Signal Field Strength - Direct measurement of field strength

Power Setting = 18.5

Frequency	Level	Pol	15.209 / 15.247		Detector	Azimuth	Height	Comments
MHz	dB μ V/m	v/h	Limit	Margin	Pk/QP/Avg	degrees	meters	
2484.180	52.6	H	54.0	-1.4	AVG	192	1.8	POS; RB 1 MHz; VB: 10 Hz
2484.130	73.1	H	74.0	-0.9	PK	192	1.8	POS; RB 1 MHz; VB: 3 MHz



EMC Test Data

Client: Pace Americas, Inc.	Job Number: JD100298
Model: Wi-Fi Module 2.4 GHz	T-Log Number: T100355
Contact: Mark Rieger	Project Manager: Irene Radamacher
Standard: FCC Part 15.247	Project Coordinator: -
	Class: N/A

Run #4: Radiated Bandedge Measurements

Date of Test: 01/06/16 Config. Used: 1
 Test Engineer: Eddie Mariscal Config Change: none
 Test Location: FT Chamber#7 EUT Voltage: 120V/60Hz

Channel: 3 Mode: n40 Target Power Setting: 24.5
 Tx Chain: 3x3 Data Rate: MCS 0 Passing Power Setting: 19.5

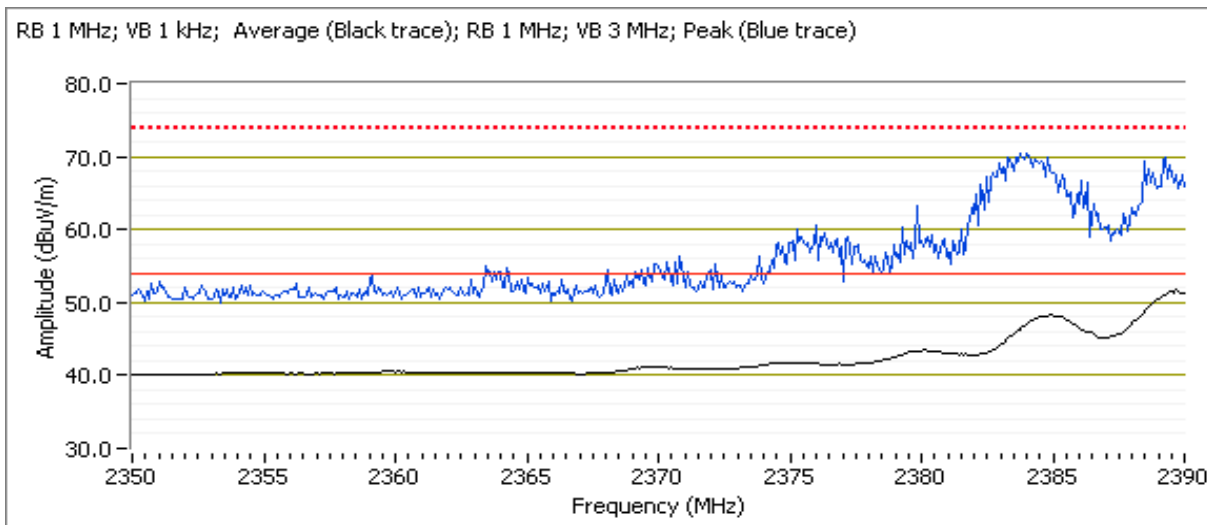

Band Edge Signal Field Strength - Direct measurement of field strength

Power Setting = 19.5

Frequency	Level	Pol	15.209 / 15.247		Detector	Azimuth	Height	Comments
MHz	dB μ V/m	v/h	Limit	Margin	Pk/QP/Avg	degrees	meters	
2389.690	52.7	H	54.0	-1.3	RMS	252	1.7	Note 4
2389.160	70.9	H	74.0	-3.1	PK	252	1.7	POS; RB 1 MHz; VB: 3 MHz



EMC Test Data

Client: Pace Americas, Inc.	Job Number: JD100298
Model: Wi-Fi Module 2.4 GHz	T-Log Number: T100355
Contact: Mark Rieger	Project Manager: Irene Radamacher
Standard: FCC Part 15.247	Project Coordinator: -
	Class: N/A

Channel: 4 Mode: n40 Target Power Setting: 24.5
 Tx Chain: 3x3 Data Rate: MCS 0 Passing Power Setting: 20.5

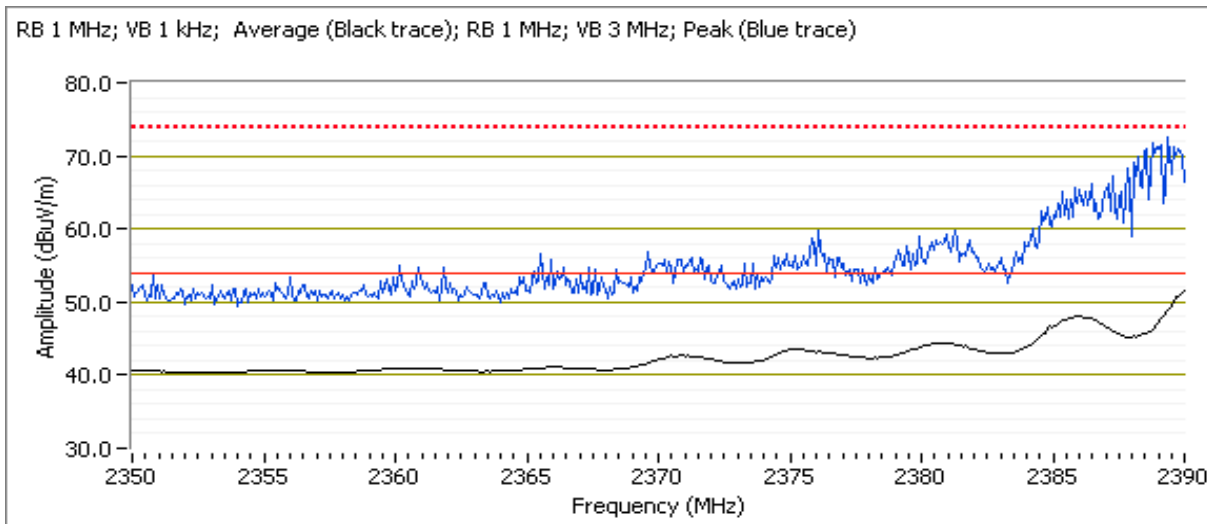

Band Edge Signal Field Strength - Direct measurement of field strength

Power Setting = 20.5

Frequency	Level	Pol	15.209 / 15.247		Detector	Azimuth	Height	Comments
MHz	dB μ V/m	v/h	Limit	Margin	PK/QP/Avg	degrees	meters	
2390.000	52.2	H	54.0	-1.8	RMS	197	1.7	Note 4
2389.120	72.3	H	74.0	-1.7	PK	197	1.7	POS; RB 1 MHz; VB: 3 MHz



EMC Test Data

Client: Pace Americas, Inc.	Job Number: JD100298
Model: Wi-Fi Module 2.4 GHz	T-Log Number: T100355
Contact: Mark Rieger	Project Manager: Irene Radamacher
Standard: FCC Part 15.247	Project Coordinator: -
	Class: N/A

Channel: 5 Mode: n40 Target Power Setting: 24.5
 Tx Chain: 3x3 Data Rate: MCS 0 Passing Power Setting: 22.5

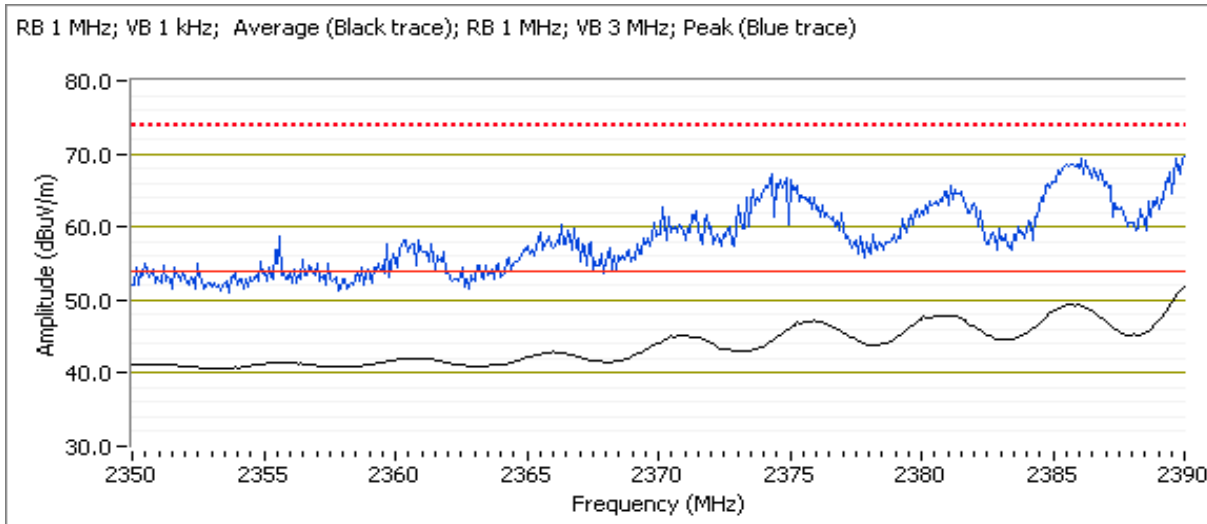

Band Edge Signal Field Strength - Direct measurement of field strength

Power Setting = 22.5

Frequency	Level	Pol	15.209 / 15.247		Detector	Azimuth	Height	Comments
MHz	dB μ V/m	v/h	Limit	Margin	Pk/QP/Avg	degrees	meters	
2389.990	52.6	H	54.0	-1.4	RMS	194	1.7	Note 4
2385.960	70.9	H	74.0	-3.1	PK	194	1.7	POS; RB 1 MHz; VB: 3 MHz



EMC Test Data

Client: Pace Americas, Inc.	Job Number: JD100298
Model: Wi-Fi Module 2.4 GHz	T-Log Number: T100355
	Project Manager: Irene Radamacher
Contact: Mark Rieger	Project Coordinator: -
Standard: FCC Part 15.247	Class: N/A

Date of Test: 01/06/16
 Test Engineer: Mehran Birgani
 Test Location: FT Chamber#7

Config. Used: 1
 Config Change: None
 EUT Voltage: 120V/60Hz

Channel: 6 Mode: n40 Target Power Setting: 24.5
 Tx Chain: 3x3 Data Rate: MCS 0 Passing Power Setting: 18.0

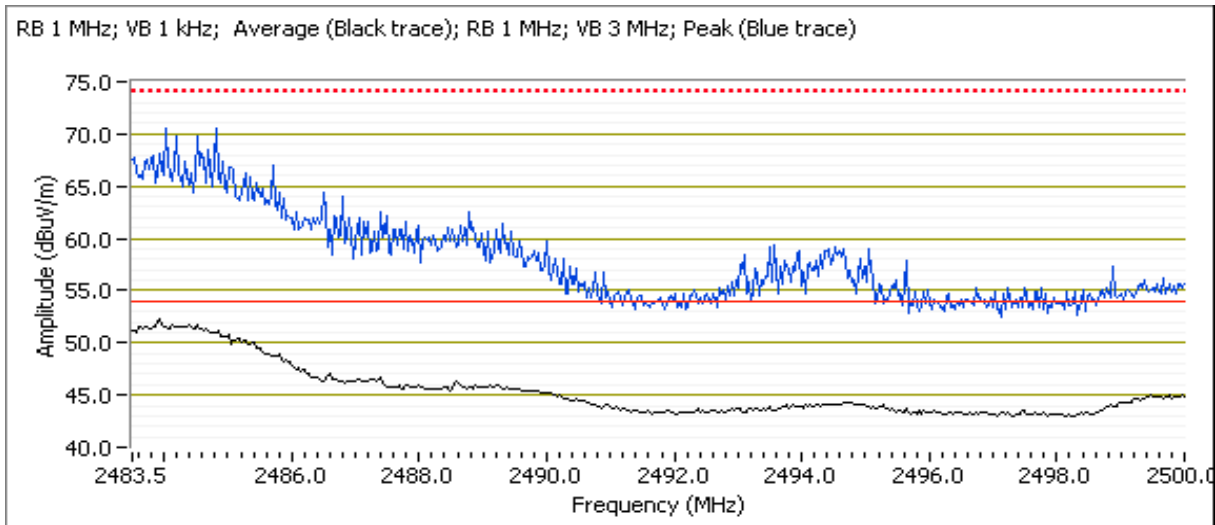

Band Edge Signal Field Strength - Direct measurement of field strength

Power Setting = 18.0

Frequency	Level	Pol	15.209 / 15.247		Detector	Azimuth	Height	Comments
MHz	dBuV/m	v/h	Limit	Margin	Pk/QP/Avg	degrees	meters	
2483.660	52.7	H	54.0	-1.3	RMS	191	1.2	Note 4
2483.520	50.8	V	54.0	-3.2	RMS	230	1.2	Note 4
2484.420	70.6	H	74.0	-3.4	PK	191	1.2	POS; RB 1 MHz; VB: 3 MHz
2485.850	67.0	V	74.0	-7.0	PK	230	1.2	POS; RB 1 MHz; VB: 3 MHz



EMC Test Data

Client: Pace Americas, Inc.	Job Number: JD100298
Model: Wi-Fi Module 2.4 GHz	T-Log Number: T100355
	Project Manager: Irene Radamacher
Contact: Mark Rieger	Project Coordinator: -
Standard: FCC Part 15.247	Class: N/A

Date of Test: 01/06/16
 Test Engineer: Mehran Birgani
 Test Location: FT Chamber#7

Config. Used: 1
 Config Change: None
 EUT Voltage: 120V/60Hz

Channel: 7 Mode: n40 Target Power Setting: 24.5
 Tx Chain: 3x3 Data Rate: MCS 0 Passing Power Setting: 16.5

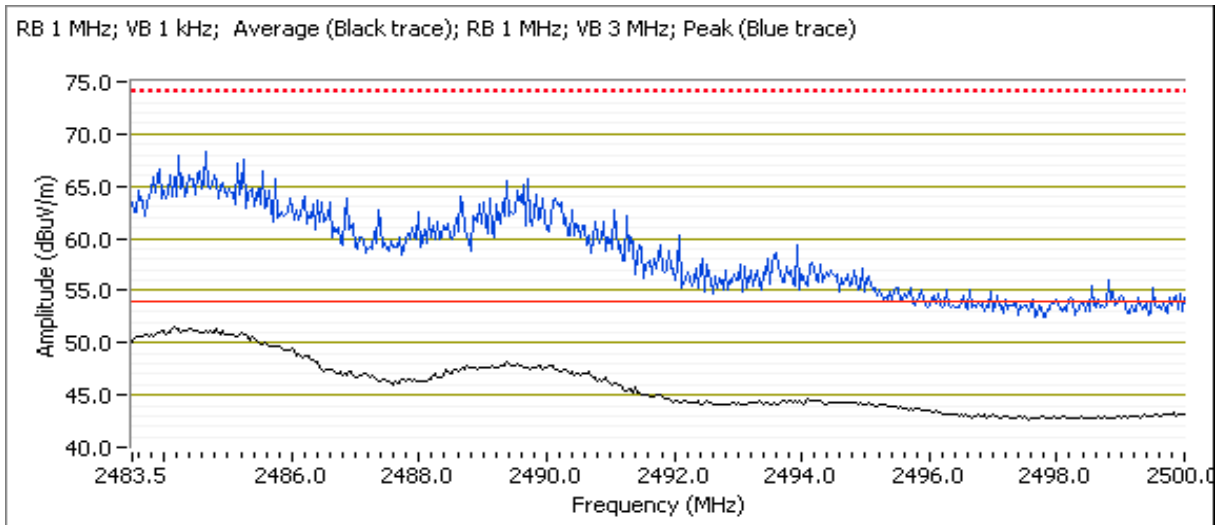

Band Edge Signal Field Strength - Direct measurement of field strength

Power Setting = 16.5

Frequency	Level	Pol	15.209 / 15.247		Detector	Azimuth	Height	Comments
MHz	dBuV/m	v/h	Limit	Margin	Pk/QP/Avg	degrees	meters	
2484.280	52.6	H	54.0	-1.4	RMS	194	1.1	Note 4
2484.950	50.3	V	54.0	-3.7	RMS	318	1.1	Note 4
2484.890	68.0	H	74.0	-6.0	PK	194	1.1	POS; RB 1 MHz; VB: 3 MHz
2484.830	67.4	V	74.0	-6.6	PK	318	1.1	POS; RB 1 MHz; VB: 3 MHz



EMC Test Data

Client: Pace Americas, Inc.	Job Number: JD100298
Model: Wi-Fi Module 2.4 GHz	T-Log Number: T100355
	Project Manager: Irene Radamacher
Contact: Mark Rieger	Project Coordinator: -
Standard: FCC Part 15.247	Class: N/A

Date of Test: 01/06/16
 Test Engineer: Mehran Birgani
 Test Location: FT Chamber#7

Config. Used: 1
 Config Change: None
 EUT Voltage: 120V/60Hz

Channel: 8 Mode: n40 Target Power Setting: 24.5
 Tx Chain: 3x3 Data Rate: MCS 0 Passing Power Setting: 15.5

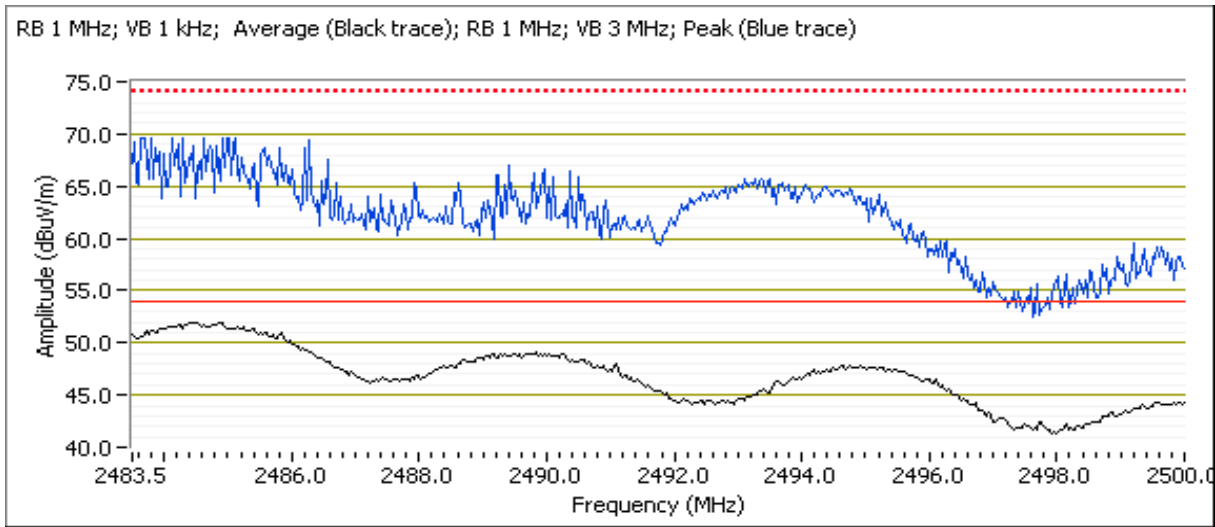

Band Edge Signal Field Strength - Direct measurement of field strength

Power Setting = 13.0

Frequency	Level	Pol	15.209 / 15.247		Detector	Azimuth	Height	Comments
MHz	dB μ V/m	v/h	Limit	Margin	Pk/QP/Avg	degrees	meters	
2484.190	53.8	H	54.0	-0.2	RMS	194	1.9	Note 4
2484.310	71.8	H	74.0	-2.2	PK	194	1.9	POS; RB 1 MHz; VB: 3 MHz
2485.520	51.8	V	54.0	-2.2	RMS	194	1.4	Note 4
2486.130	67.3	V	74.0	-6.7	PK	194	1.4	POS; RB 1 MHz; VB: 3 MHz



EMC Test Data

Client: Pace Americas, Inc.	Job Number: JD100298
Model: Wi-Fi Module 2.4 GHz	T-Log Number: T100355
Contact: Mark Rieger	Project Manager: Irene Radamacher
Standard: FCC Part 15.247	Project Coordinator: -
	Class: N/A

Channel: 9 Mode: n40 Target Power Setting: 24.5
 Tx Chain: 3x3 Data Rate: MCS 0 Passing Power Setting: 14.5

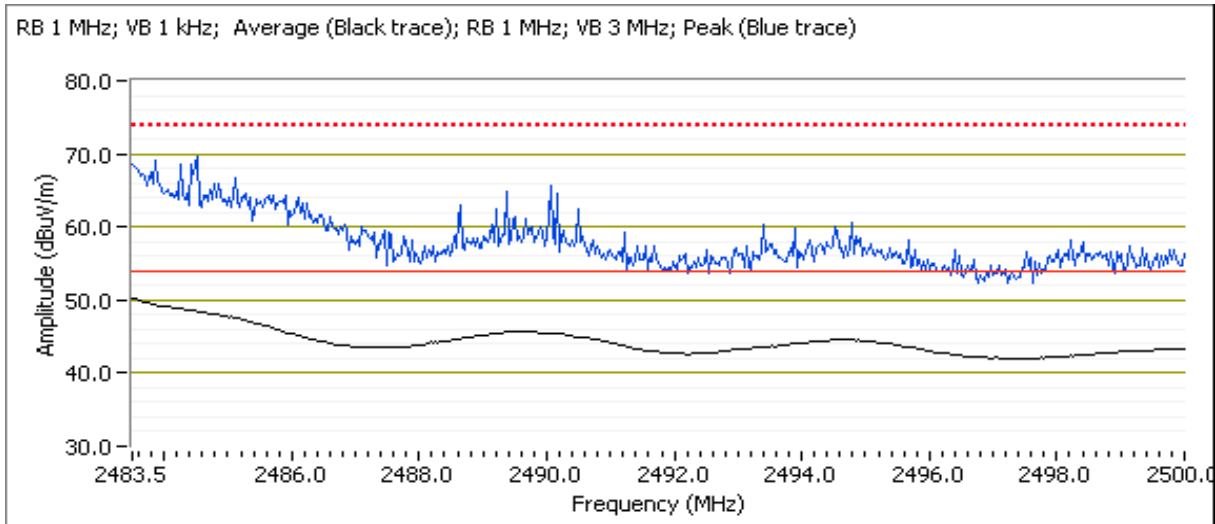

Band Edge Signal Field Strength - Direct measurement of field strength

Power Setting = 14.5

Frequency	Level	Pol	15.209 / 15.247		Detector	Azimuth	Height	Comments
MHz	dB μ V/m	v/h	Limit	Margin	PK/QP/Avg	degrees	meters	
2483.760	53.3	H	54.0	-0.7	RMS	194	1.5	Note 4
2488.290	68.5	H	74.0	-5.5	PK	194	1.5	POS; RB 1 MHz; VB: 3 MHz

Note 4: Emission has constant duty cycle < 98%, average measurement performed: RBW=1MHz, VBW=3MHz, RMS, Power averaging, auto sweep, trace average 100 traces, measurement corrected by Pwr correction factor



EMC Test Data

Client:	Pace Americas, Inc.	Job Number:	JD100298
Model:	Wi-Fi Module 2.4 GHz	T-Log Number:	T100355
		Project Manager:	Irene Radamacher
Contact:	Mark Rieger	Project Coordinator:	-
Standard:	FCC Part 15.247	Class:	N/A

RSS-247 and FCC 15.247 (DTS) Radiated Spurious Emissions

Test Specific Details

Objective: The objective of this test session is to perform final qualification testing of the EUT with respect to the specification listed above.

General Test Configuration

The EUT and all local support equipment were located on the turntable for radiated spurious emissions testing.

For radiated emissions testing the measurement antenna was located 3 meters from the EUT, unless otherwise noted.

Ambient Conditions:

Temperature: 21.4 °C
Rel. Humidity: 35 %

Summary of Results - Device Operating in the 2400-2483.5 MHz Band

Run #	Mode	Channel	Target Power	Power Setting	Test Performed	Limit	Result / Margin
Scans on center channel in all three OFDM modes to determine the worst case mode.							
2	n20	6 - 2437MHz	24.5	24.5	Radiated Emissions, 1 - 25 GHz	FCC Part 15.209 / 15.247(c)	50.1 dBµV/m @ 9999.9 MHz (-3.9 dB)
	n40	6 - 2437MHz	24.5	24.5	Radiated Emissions, 1 - 25 GHz	FCC Part 15.209 / 15.247(c)	50.0 dBµV/m @ 9999.9 MHz (-4.0 dB)
Measurements on low and high channels in worst-case OFDM mode.							
3	n20	1 - 2412MHz	24.5	24.5	Radiated Emissions, 1 - 25 GHz	FCC Part 15.209 / 15.247(c)	47.7 dBµV/m @ 1625.0 MHz (-6.3 dB)
	n20	11 - 2462MHz	24.5	25.0	Radiated Emissions, 1 - 25 GHz	FCC Part 15.209 / 15.247(c)	53.6 dBµV/m @ 10000.0 MHz (-0.4 dB)



EMC Test Data

Client:	Pace Americas, Inc.	Job Number:	JD100298
Model:	Wi-Fi Module 2.4 GHz	T-Log Number:	T100355
		Project Manager:	Irene Radamacher
Contact:	Mark Rieger	Project Coordinator:	-
Standard:	FCC Part 15.247	Class:	N/A

Modifications Made During Testing

No modifications were made to the EUT during testing

Deviations From The Standard

No deviations were made from the requirements of the standard.

Sample Notes

Sample S/N: PAV80000005
 Driver: 2.24 BL 2.56 SW
 Antenna: 3 Tx (Beamforming modes)

Procedure Comments:

Measurements performed in accordance with FCC KDB 558074
 Peak measurements performed with: RBW=1MHz, VBW=3MHz, peak detector, max hold, auto sweep time
 Unless otherwise stated/noted, emission has duty cycle $\geq 98\%$ and was measured using RBW=1MHz, VBW=10Hz, peak detector, linear average mode, auto sweep time, max hold.
 2.4GHz band reject filter used

Mode	Data Rate	Duty Cycle (x)	Constant DC?	T (ms)	Pwr Cor Factor*	Lin Volt Cor Factor**	Min VBW for FS (Hz)
n20	MCS0	0.97	Y	3.841	0.1	0.3	260
n40	MCS0	0.97	Y	4.575	0.1	0.2	219

Measurement Specific Notes:

Note 1:	Emission in non-restricted band, but limit of 15.209 used.
Note 2:	Emission in non-restricted band, the limit was set 30dB below the level of the fundamental and measured in 100kHz.
Note 3:	Emission has a duty cycle $\geq 98\%$, average measurement performed: RBW=1MHz, VBW=3MHz, RMS, Power averaging, auto sweep, trace average 100 traces
Note 4:	Emission has constant duty cycle $< 98\%$, average measurement performed: RBW=1MHz, VBW> $> 1/T$ but not less than 10Hz, peak detector, linear averaging, auto sweep, trace average 100 traces, measurement corrected by Linear voltage correction factor
Note 5:	Emission has constant duty cycle $< 98\%$, average measurement performed: RBW=1MHz, VBW=3MHz, RMS, Power averaging, auto sweep, trace average 100 traces, measurement corrected by Pwr correction factor
Note 6:	Emission has non constant duty cycle $< 98\%$, average measurement performed: RBW=1MHz, VBW> $> 1/T$, peak detector, linear average mode, sweep time auto, max hold. Max hold for $50*(1/DC)$ traces
Note 7:	Emission has non constant duty cycle $< 98\%$, average measurement performed: RBW=1MHz, VBW> $> 1/T$, RMS detector, sweep time auto, max hold. Max hold for $50*(1/DC)$ traces

Client: Pace Americas, Inc.	Job Number: JD100298
Model: Wi-Fi Module 2.4 GHz	T-Log Number: T100355
Contact: Mark Rieger	Project Manager: Irene Radamacher
Standard: FCC Part 15.247	Project Coordinator: -
	Class: N/A

Run #2: Radiated Spurious Emissions, 1,000 - 25000 MHz. Operating Mode: OFDM

Date of Test: 02/04/16

Test Location: FT Chamber #7

Test Engineer: Rafael Varelas

EUT Voltage: 120V/60Hz

Run #2b: Center Channel

Channel: 6

Mode: n20

Tx Chain: 3x3

Data Rate: MCS0

Frequency MHz	Level dB μ V/m	Pol v/h	15.209 / 15.247		Detector PK/QP/Avg	Azimuth degrees	Height meters	Comments
			Limit	Margin				
9999.850	50.1	V	54.0	-3.9	Avg	340	1.0	RB 1 MHz;VB 300 Hz;Peak VAVG 50
9999.720	55.7	V	74.0	-18.3	PK	340	1.0	RB 1 MHz;VB 3 MHz;Peak
4999.950	43.7	V	54.0	-10.3	Avg	261	1.0	RB 1 MHz;VB 300 Hz;Peak VAVG 50
4999.890	48.4	V	74.0	-25.6	PK	261	1.0	RB 1 MHz;VB 3 MHz;Peak
2766.250	42.4	H	54.0	-11.6	Avg	270	1.1	RB 1 MHz;VB 300 Hz;Peak VAVG 50
2767.250	53.2	H	74.0	-20.8	PK	270	1.1	RB 1 MHz;VB 3 MHz;Peak
3272.490	30.2	H	54.0	-23.8	Avg	238	1.8	RB 1 MHz;VB 300 Hz;Peak VAVG 50
3272.800	43.1	H	74.0	-30.9	PK	238	1.8	RB 1 MHz;VB 3 MHz;Peak
1625.010	46.8	V	54.0	-7.2	Avg	194	2.3	RB 1 MHz;VB 300 Hz;Peak VAVG 50
1624.940	49.4	V	74.0	-24.6	PK	194	2.3	RB 1 MHz;VB 3 MHz;Peak
1875.010	49.2	V	54.0	-4.8	Avg	188	2.2	RB 1 MHz;VB 300 Hz;Peak VAVG 50
1875.020	52.0	V	74.0	-22.0	PK	188	2.2	RB 1 MHz;VB 3 MHz;Peak
4874.570	33.6	V	54.0	-20.4	Avg	35	1.2	RB 1 MHz;VB 300 Hz;Peak VAVG 50
4873.790	46.0	V	74.0	-28.0	PK	35	1.2	RB 1 MHz;VB 3 MHz;Peak

Note: Scans made between 18 - 25 GHz with the measurement antenna moved around the card and its antennas 20-50cm from the device indicated there were no significant emissions in this frequency range

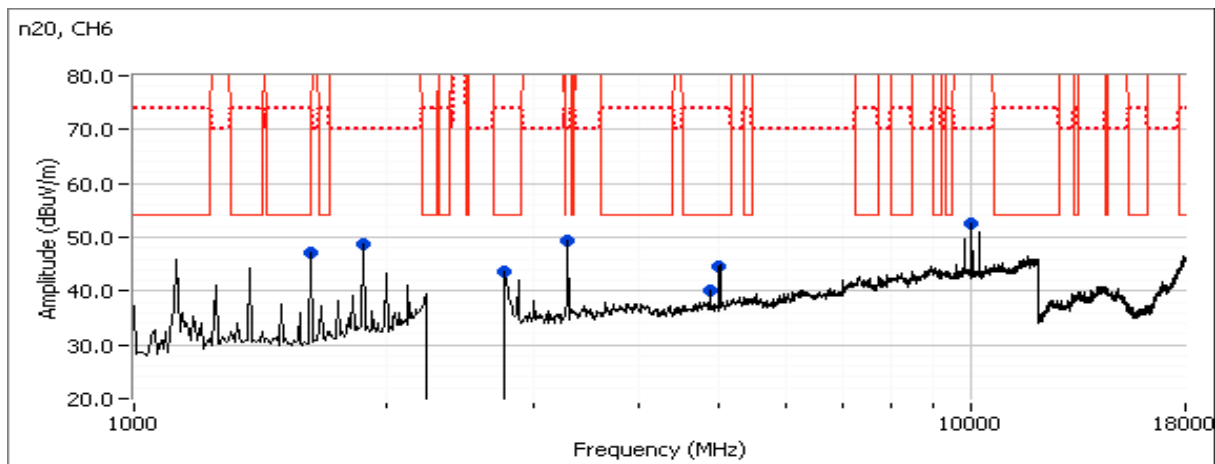



EMC Test Data

Client: Pace Americas, Inc.	Job Number: JD100298
Model: Wi-Fi Module 2.4 GHz	T-Log Number: T100355
Contact: Mark Rieger	Project Manager: Irene Radamacher
Standard: FCC Part 15.247	Project Coordinator: -
	Class: N/A

Run #2c: Center Channel

Channel: 6 Mode: n40
 Tx Chain: 3x3 Data Rate: MCS0

Frequency	Level	Pol	15.209 / 15.247		Detector	Azimuth	Height	Comments
MHz	dB μ V/m	v/h	Limit	Margin	PK/QP/Avg	degrees	meters	
9999.910	50.0	V	54.0	-4.0	Avg	360	1.0	RB 1 MHz;VB 300 Hz;Peak VAVG 50
10000.060	56.1	V	74.0	-13.9	PK	360	1.0	RB 1 MHz;VB 3 MHz;Peak
4999.970	46.0	V	54.0	-8.0	Avg	278	1.6	RB 1 MHz;VB 300 Hz;Peak VAVG 50
5021.080	45.1	V	74.0	-28.9	PK	278	1.6	RB 1 MHz;VB 3 MHz;Peak
4898.020	32.4	V	54.0	-21.6	Avg	262	2.4	RB 1 MHz;VB 300 Hz;Peak VAVG 50
4898.880	44.9	V	74.0	-29.1	PK	262	2.4	RB 1 MHz;VB 3 MHz;Peak
2760.990	42.7	V	54.0	-11.3	Avg	131	1.0	RB 1 MHz;VB 300 Hz;Peak VAVG 50
2764.800	55.0	V	74.0	-19.0	PK	131	1.0	RB 1 MHz;VB 3 MHz;Peak
1125.000	45.2	H	54.0	-8.8	Peak	107	2.2	Not from radio
1625.000	46.9	V	54.0	-7.1	Peak	206	1.9	Not from radio
1875.000	47.5	V	70.0	-22.5	Peak	200	1.9	Not from radio

Note: Scans made between 18 - 25 GHz with the measurement antenna moved around the card and its antennas 20-50cm from the device indicated there were no significant emissions in this frequency range

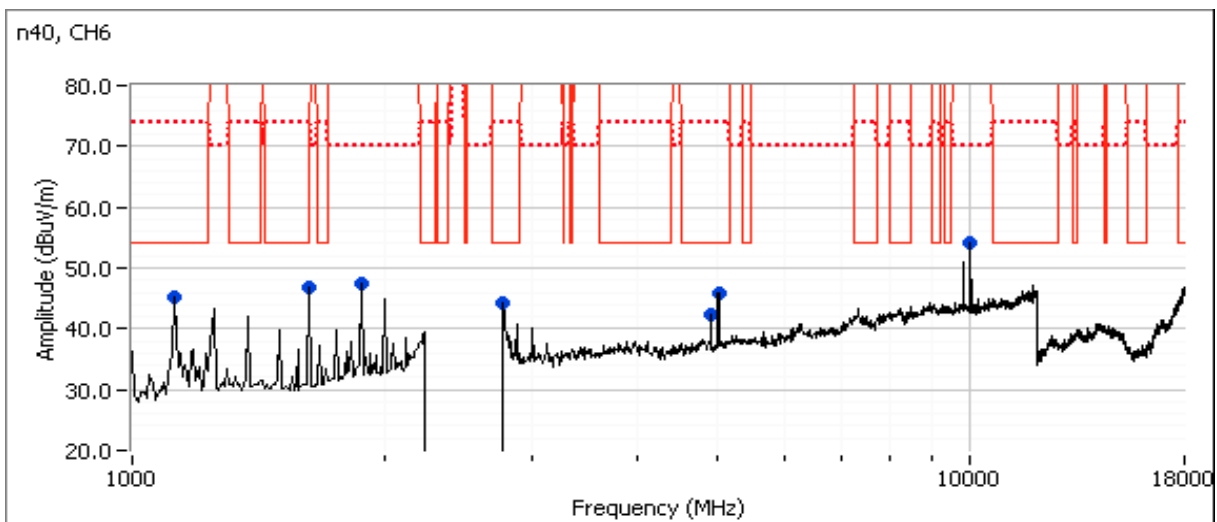



EMC Test Data

Client: Pace Americas, Inc.	Job Number: JD100298
Model: Wi-Fi Module 2.4 GHz	T-Log Number: T100355
Contact: Mark Rieger	Project Manager: Irene Radamacher
Standard: FCC Part 15.247	Project Coordinator: -
	Class: N/A

Run #3: Radiated Spurious Emissions, 1,000 - 25000 MHz. Operating Mode: Worse case from Run #2

Date of Test: 02/04/16 Test Location: FT Chamber #7
 Test Engineer: R. Varelas & M. Birgani EUT Voltage: 120V/60Hz

Run #3a: Low Channel

Channel: 1 Mode: n20 Target Power Setting: 24.5
 Tx Chain: 3x3 Data Rate: MCS0 Passing Power Setting: 24.5

Frequency	Level	Pol	15.209 / 15.247		Detector	Azimuth	Height	Comments
MHz	dB μ V/m	v/h	Limit	Margin	Pk/QP/Avg	degrees	meters	
1625.030	47.7	V	54.0	-6.3	AVG	205	2.2	RB 1 MHz;VB 10 Hz;Peak
4999.930	44.4	V	54.0	-9.6	AVG	270	1.6	RB 1 MHz;VB 10 Hz;Peak
1125.010	43.6	H	54.0	-10.4	AVG	147	2.2	RB 1 MHz;VB 10 Hz;Peak
1625.090	50.1	V	74.0	-23.9	PK	205	2.2	RB 1 MHz;VB 3 MHz;Peak
4999.940	49.6	V	74.0	-24.4	PK	270	1.6	RB 1 MHz;VB 3 MHz;Peak
1125.050	47.8	H	74.0	-26.2	PK	147	2.2	RB 1 MHz;VB 3 MHz;Peak

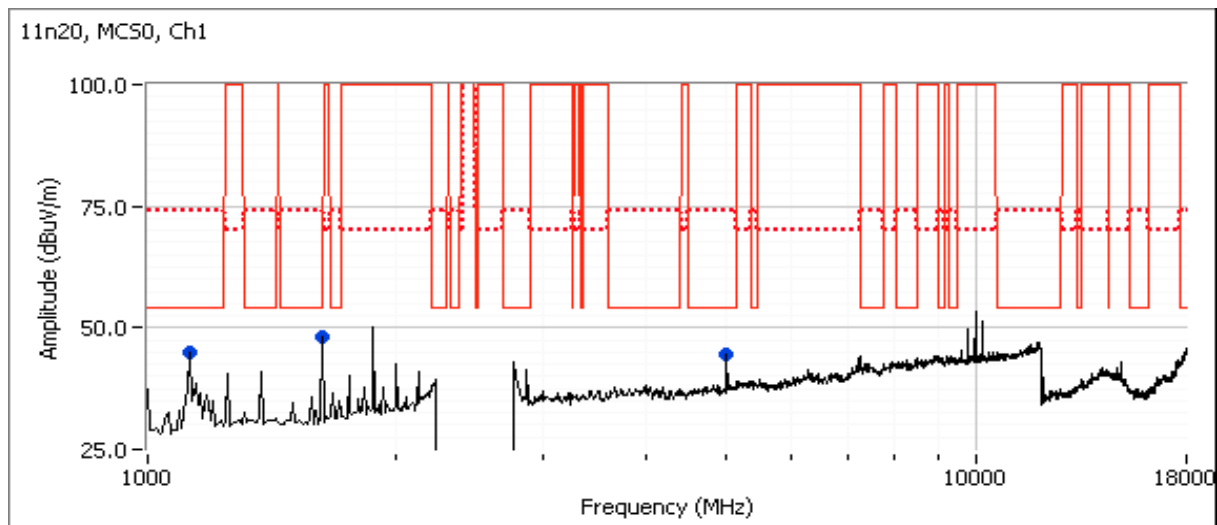



EMC Test Data

Client: Pace Americas, Inc.	Job Number: JD100298
Model: Wi-Fi Module 2.4 GHz	T-Log Number: T100355
Contact: Mark Rieger	Project Manager: Irene Radamacher
Standard: FCC Part 15.247	Project Coordinator: -
	Class: N/A

Run #3b: High Channel

Channel: 11 Mode: n20
 Tx Chain: 3x3 Data Rate: MCS0

Frequency MHz	Level dB μ V/m	Pol v/h	15.209 / 15.247		Detector PK/QP/Avg	Azimuth degrees	Height meters	Comments
			Limit	Margin				
9999.980	53.6	V	54.0	-0.4	Avg	345	1.3	Note 1, RB 1 MHz; VB 300 Hz; Peak V
10000.040	58.1	V	74.0	-15.9	PK	345	1.3	RB 1 MHz; VB 3 MHz; Peak
2766.030	42.8	H	54.0	-11.2	Avg	10	2.1	RB 1 MHz; VB 300 Hz; Peak VAVG 50
2764.730	55.4	H	74.0	-18.6	PK	10	2.1	RB 1 MHz; VB 3 MHz; Peak
4999.990	45.3	V	54.0	-8.7	Avg	290	1.5	RB 1 MHz; VB 300 Hz; Peak VAVG 50
4999.900	50.2	V	74.0	-23.8	PK	290	1.5	RB 1 MHz; VB 3 MHz; Peak

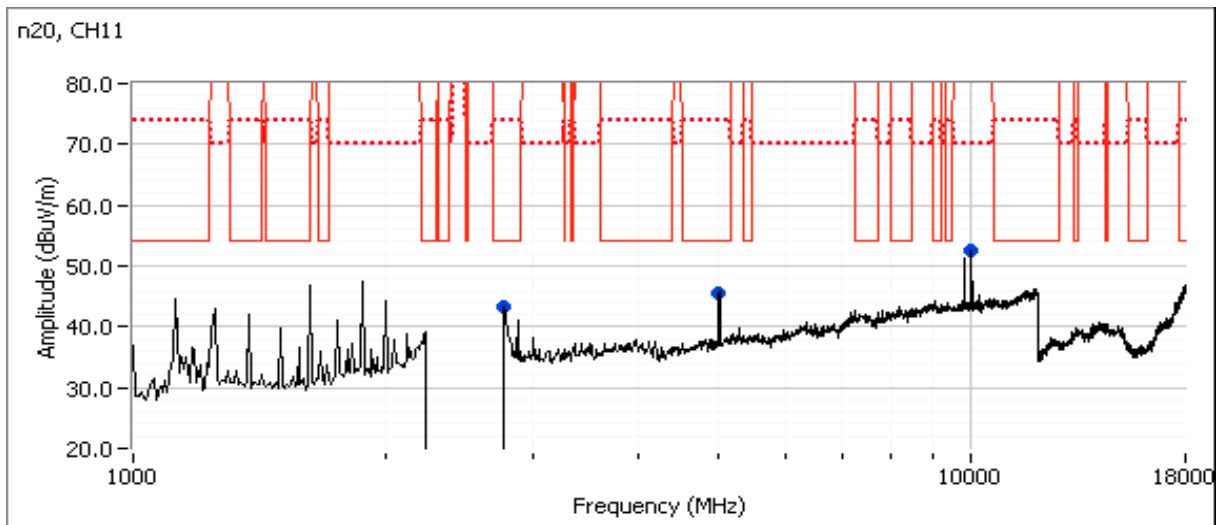



EMC Test Data

Client:	Pace Americas, Inc.	Job Number:	JD100298
Model:	Wi-Fi Module 2.4 GHz	T-Log Number:	T100355
		Project Manager:	Irene Radmacher
Contact:	Mark Rieger	Project Coordinator:	-
Standard:	FCC Part 15.247	Class:	N/A

RSS-247 and FCC 15.247 (DTS) Radiated Spurious Emissions

Test Specific Details

Objective: The objective of this test session is to perform final qualification testing of the EUT with respect to the specification listed above.

General Test Configuration

The EUT and all local support equipment were located on the turntable for radiated spurious emissions testing.

For radiated emissions testing the measurement antenna was located 3 meters from the EUT, unless otherwise noted.

Ambient Conditions:

Temperature: 25 °C
Rel. Humidity: 30 %

Modifications Made During Testing

No modifications were made to the EUT during testing

Deviations From The Standard

No deviations were made from the requirements of the standard.

Sample Notes

Sample S/N: F55154470184
Driver: 7.14.89.21.571.206
Antenna: 3 Tx (Non beamforming modes)



EMC Test Data

Client: Pace Americas, Inc.	Job Number: JD100298
Model: Wi-Fi Module 2.4 GHz	T-Log Number: T100355
	Project Manager: Irene Radamacher
Contact: Mark Rieger	Project Coordinator: -
Standard: FCC Part 15.247	Class: N/A

Summary of Results - Device Operating in the 2400-2483.5 MHz Band

Run #	Mode	Channel	Target Power	Power Setting	Test Performed	Limit	Result / Margin
1	b	1 - 2412MHz	26	26.0	Radiated Emissions, 1 - 25 GHz	FCC Part 15.209 / 15.247(c)	45.7 dBµV/m @ 4824.0 MHz (-8.3 dB)
	b	6 - 2437MHz	27	27.0	Radiated Emissions, 1 - 25 GHz	FCC Part 15.209 / 15.247(c)	52.9 dBµV/m @ 7311.8 MHz (-1.1 dB)
	b	11 - 2462MHz	26	26.0	Radiated Emissions, 1 - 25 GHz	FCC Part 15.209 / 15.247(c)	49.8 dBµV/m @ 7388.2 MHz (-4.2 dB)
Scans on center channel in all three OFDM modes to determine the worst case mode.							
2	g	6 - 2437MHz	27.0	27.0	Radiated Emissions, 1 - 25 GHz	FCC Part 15.209 / 15.247(c)	48.1 dBµV/m @ 7310.2 MHz (-5.9 dB)
	n20	6 - 2437MHz	24.5	24.5	Radiated Emissions, 1 - 25 GHz	FCC Part 15.209 / 15.247(c)	44.4 dBµV/m @ 7310.3 MHz (-9.6 dB)
	n40	6 - 2437MHz	24.5	24.5	Radiated Emissions, 1 - 25 GHz	FCC Part 15.209 / 15.247(c)	46.5 dBµV/m @ 5000.0 MHz (-7.5 dB)
Measurements on low and high channels in worst-case OFDM mode.							
3	n40	1 - 2412MHz	24.5	24.5	Radiated Emissions, 1 - 25 GHz	FCC Part 15.209 / 15.247(c)	45.1 dBµV/m @ 5000.0 MHz (-8.9 dB)
		11 - 2462MHz	24.5	24.5	Radiated Emissions, 1 - 25 GHz	FCC Part 15.209 / 15.247(c)	44.4 dBµV/m @ 5000.0 MHz (-9.6 dB)

Client:	Pace Americas, Inc.	Job Number:	JD100298
Model:	Wi-Fi Module 2.4 GHz	T-Log Number:	T100355
		Project Manager:	Irene Radamacher
Contact:	Mark Rieger	Project Coordinator:	-
Standard:	FCC Part 15.247	Class:	N/A

Procedure Comments:

Measurements performed in accordance with FCC KDB 558074

Peak measurements performed with: RBW=1MHz, VBW=3MHz, peak detector, max hold, auto sweep time

Unless otherwise stated/noted, emission has duty cycle $\geq 98\%$ and was measured using RBW=1MHz, VBW=10Hz, peak detector, linear average mode, auto sweep time, max hold.

2.4GHz band reject filter used

Mode	Data Rate	Duty Cycle (x)	Constant DC?	T (ms)	Pwr Cor Factor*	Lin Volt Cor Factor**	Min VBW for FS (Hz)
11b	2 Mb/s	1.00	Yes	10	0.0	0.0	100
11g	6 Mb/s	0.99	Yes	2.157	0.0	0.0	464
n20	MCS 0	0.98	Yes	2.018	0.0	0.0	496
n40	MCS 0	0.90	Yes	1.249	0.4	0.9	801

Measurement Specific Notes:

Note 1:	Emission in non-restricted band, but limit of 15.209 used.
Note 2:	Emission in non-restricted band, the limit was set 30dB below the level of the fundamental and measured in 100kHz.
Note 3:	Emission has a duty cycle $\geq 98\%$, average measurement performed: RBW=1MHz, VBW=3MHz, RMS, Power averaging, auto sweep, trace average 100 traces
Note 4:	Emission has constant duty cycle $< 98\%$, average measurement performed: RBW=1MHz, VBW> $> 1/T$ but not less than 10Hz, peak detector, linear averaging, auto sweep, trace average 100 traces, measurement corrected by Linear voltage correction factor
Note 5:	Emission has constant duty cycle $< 98\%$, average measurement performed: RBW=1MHz, VBW=3MHz, RMS, Power averaging, auto sweep, trace average 100 traces, measurement corrected by Pwr correction factor
Note 6:	Emission has non constant duty cycle $< 98\%$, average measurement performed: RBW=1MHz, VBW> $> 1/T$, peak detector, linear average mode, sweep time auto, max hold. Max hold for $50 \cdot (1/DC)$ traces
Note 7:	Emission has non constant duty cycle $< 98\%$, average measurement performed: RBW=1MHz, VBW> $> 1/T$, RMS detector, sweep time auto, max hold. Max hold for $50 \cdot (1/DC)$ traces



EMC Test Data

Client: Pace Americas, Inc.	Job Number: JD100298
Model: Wi-Fi Module 2.4 GHz	T-Log Number: T100355
	Project Manager: Irene Radamacher
Contact: Mark Rieger	Project Coordinator: -
Standard: FCC Part 15.247	Class: N/A

Run #1: Radiated Spurious Emissions, 1,000 - 25000 MHz. Operating Mode: 802.11b
 Date of Test: 1/5/2016 0:00 Config. Used: 1
 Test Engineer: Eddie Mariscal Config Change: none
 Test Location: FT Chamber#7 EUT Voltage: 120V/60Hz

Run #1a: Low Channel

Channel: 1 Mode: b
 Tx Chain: 3x3 Data Rate: 2 Mb/s

Frequency	Level	Pol	15.209 / 15.247		Detector	Azimuth	Height	Comments
MHz	dB μ V/m	v/h	Limit	Margin	Pk/QP/Avg	degrees	meters	
4824.020	45.7	V	54.0	-8.3	AVG	231	1.6	RB 1 MHz;VB 10 Hz;Peak
4823.900	52.5	V	74.0	-21.5	PK	231	1.6	RB 1 MHz;VB 3 MHz;Peak
4999.940	44.7	V	54.0	-9.3	AVG	272	1.8	RB 1 MHz;VB 10 Hz;Peak
4999.990	50.1	V	74.0	-23.9	PK	272	1.8	RB 1 MHz;VB 3 MHz;Peak
7238.270	52.1	V	100.0	-47.9	AVG	292	1.4	RB 1 MHz;VB 10 Hz;Peak
7235.900	58.5	V	70.0	-11.5	PK	292	1.4	RB 1 MHz;VB 3 MHz;Peak
9999.900	53.6	V	100.0	-46.4	AVG	351	2.2	RB 1 MHz;VB 10 Hz;Peak
9999.930	58.0	V	70.0	-12.0	PK	351	2.2	RB 1 MHz;VB 3 MHz;Peak
10199.870	51.4	V	100.0	-48.6	AVG	354	2.1	RB 1 MHz;VB 10 Hz;Peak
10199.960	56.9	V	70.0	-13.1	PK	354	2.1	RB 1 MHz;VB 3 MHz;Peak

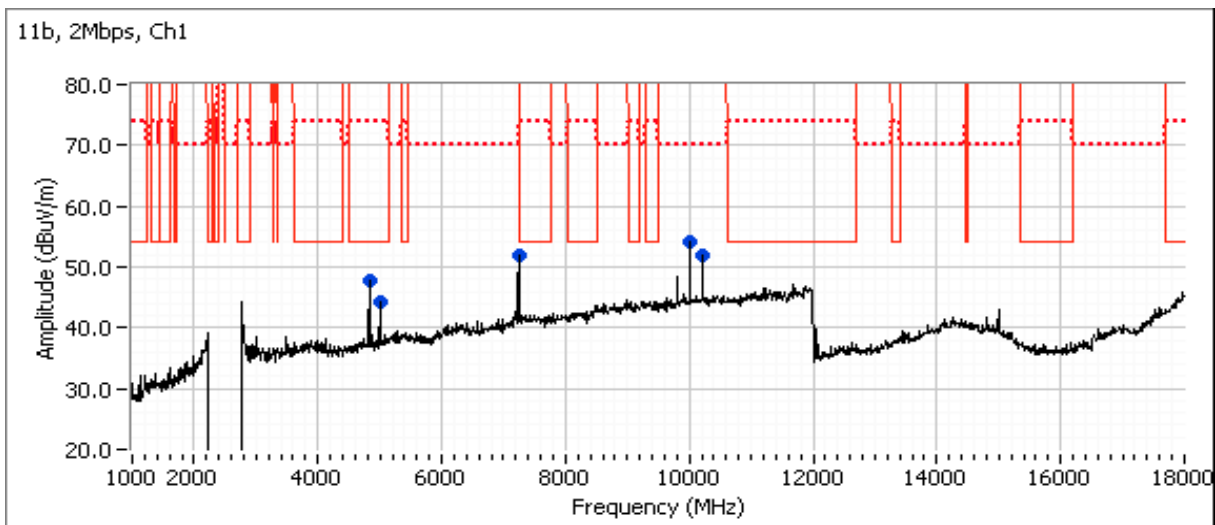

Note: Scans made between 18 - 25 GHz with the measurement antenna moved around the card and its antennas 20-50cm from the device indicated there were no significant emissions in this frequency range



EMC Test Data

Client: Pace Americas, Inc.	Job Number: JD100298
Model: Wi-Fi Module 2.4 GHz	T-Log Number: T100355
Contact: Mark Rieger	Project Manager: Irene Radamacher
Standard: FCC Part 15.247	Project Coordinator: -
	Class: N/A

Run #1b: Center Channel

Channel: 6 Mode: b
 Tx Chain: 3x3 Data Rate: 2 Mb/s

Frequency	Level	Pol	15.209 / 15.247		Detector	Azimuth	Height	Comments
MHz	dB μ V/m	v/h	Limit	Margin	PK/QP/Avg	degrees	meters	
7311.830	52.9	V	54.0	-1.1	AVG	287	1.0	RB 1 MHz;VB 10 Hz;Peak
7311.850	59.0	V	74.0	-15.0	PK	287	1.0	RB 1 MHz;VB 3 MHz;Peak
5000.010	44.4	V	54.0	-9.6	Peak	272	1.9	Note 1
10000.020	53.5	V	70.0	-16.5	Peak	355	2.2	Note 1
10200.020	52.3	V	70.0	-17.7	Peak	352	1.0	Note 1
4873.890	41.5	H	54.0	-12.5	AVG	237	1.8	RB 1 MHz;VB 10 Hz;Peak
4873.840	49.4	H	74.0	-24.6	PK	237	1.8	RB 1 MHz;VB 3 MHz;Peak
power setting 26								
7313.410	52.6	V	54.0	-1.4	AVG	289	1.3	RB 1 MHz;VB 10 Hz;Peak
7310.740	58.6	V	74.0	-15.4	PK	289	1.3	RB 1 MHz;VB 3 MHz;Peak

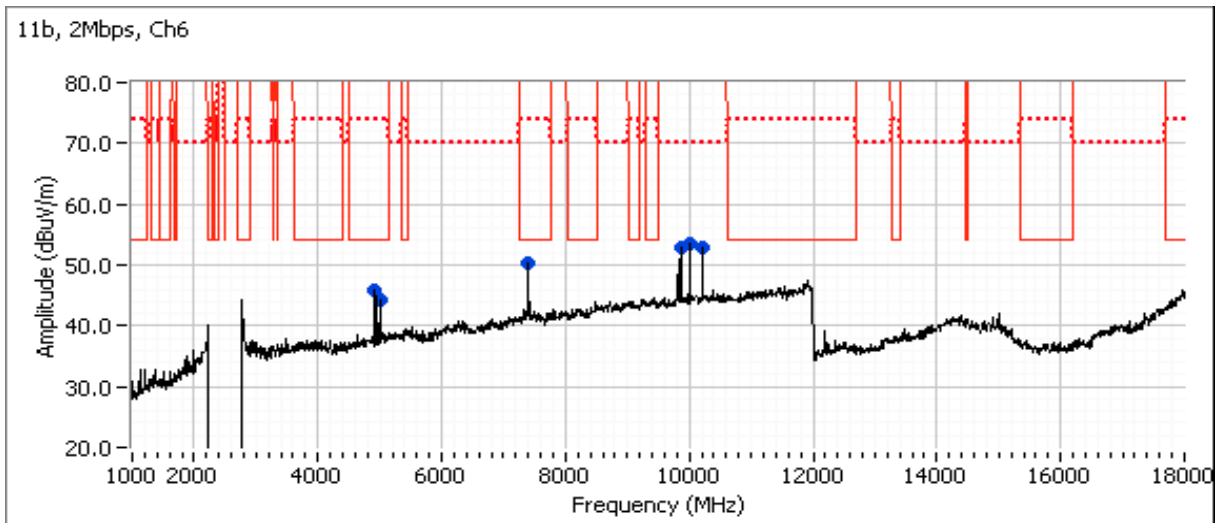

Note 1: Emissions were unrelated to radio. Final measurements were gathered under Run #1a.

Note: Scans made between 18 - 25 GHz with the measurement antenna moved around the card and its antennas 20-50cm from the device indicated there were no significant emissions in this frequency range



EMC Test Data

Client: Pace Americas, Inc.	Job Number: JD100298
Model: Wi-Fi Module 2.4 GHz	T-Log Number: T100355
Contact: Mark Rieger	Project Manager: Irene Radamacher
Standard: FCC Part 15.247	Project Coordinator: -
	Class: N/A

Run #1c: High Channel

Channel: 11 Mode: b
 Tx Chain: 3x3 Data Rate: 2 Mb/s

Frequency	Level	Pol	15.209 / 15.247		Detector	Azimuth	Height	Comments
MHz	dB μ V/m	v/h	Limit	Margin	PK/QP/Avg	degrees	meters	
5000.010	44.4	H	54.0	-9.6	Peak	281	1.6	Note 1
10000.020	53.5	V	70.0	-16.5	Peak	0	2.5	Note 1
10200.020	52.8	V	70.0	-17.2	Peak	355	2.2	Note 1
4923.930	44.3	V	54.0	-9.7	AVG	36	1.6	RB 1 MHz;VB 10 Hz;Peak
4923.840	50.9	V	74.0	-23.1	PK	36	1.6	RB 1 MHz;VB 3 MHz;Peak
7388.200	49.8	V	54.0	-4.2	AVG	288	1.3	RB 1 MHz;VB 10 Hz;Peak
7388.330	56.5	V	74.0	-17.5	PK	288	1.3	RB 1 MHz;VB 3 MHz;Peak
9847.950	52.1	V	100.0	-47.9	AVG	4	2.1	RB 1 MHz;VB 10 Hz;Peak
9847.950	57.2	V	70.0	-12.8	PK	4	2.1	RB 1 MHz;VB 3 MHz;Peak

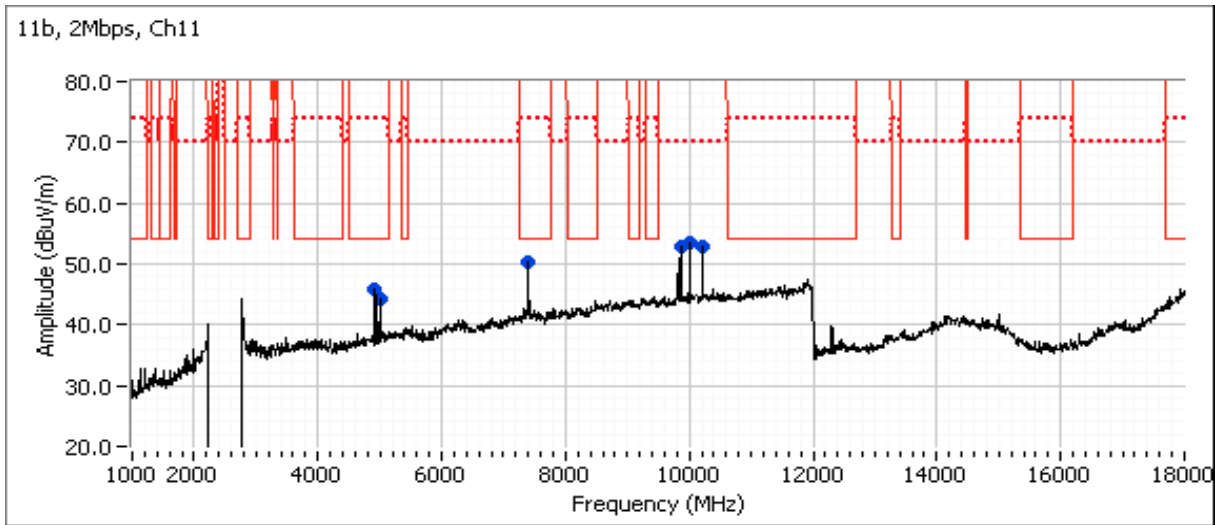

Note 1: Emissions were unrelated to radio. Final measurements were gathered under Run #1a.

Note: Scans made between 18 - 25 GHz with the measurement antenna moved around the card and its antennas 20-50cm from the device indicated there were no significant emissions in this frequency range



EMC Test Data

Client: Pace Americas, Inc.	Job Number: JD100298
Model: Wi-Fi Module 2.4 GHz	T-Log Number: T100355
	Project Manager: Irene Radamacher
Contact: Mark Rieger	Project Coordinator: -
Standard: FCC Part 15.247	Class: N/A

Run #2: Radiated Spurious Emissions, 1,000 - 25000 MHz. Operating Mode: OFDM
 Date of Test: 01/05/16 Config. Used: 1
 Test Engineer: Eddie Mariscal Config Change: None
 Test Location: FT Chamber #7 EUT Voltage: 120V/60Hz

Run #2a: Center Channel

Channel: 6 Mode: g Setting: 27
 Tx Chain: 3Tx Data Rate: 6 Mb/s

Frequency	Level	Pol	15.209 / 15.247		Detector	Azimuth	Height	Comments
MHz	dB μ V/m	v/h	Limit	Margin	Pk/QP/Avg	degrees	meters	
7310.210	48.1	V	54.0	-5.9	AVG	286	1.0	RB 1 MHz;VB 10 Hz;Peak
7311.610	61.5	V	74.0	-12.5	PK	286	1.0	RB 1 MHz;VB 3 MHz;Peak
5000.010	44.7	V	54.0	-9.3	Peak	302	2.2	Note 1
10000.020	54.5	V	70.0	-15.5	Peak	354	2.2	Note 1
10200.020	52.3	V	70.0	-17.7	Peak	355	1.9	Note 1
4873.870	37.6	V	54.0	-16.4	AVG	233	1.7	RB 1 MHz;VB 10 Hz;Peak
4869.040	50.0	V	74.0	-24.0	PK	233	1.7	RB 1 MHz;VB 3 MHz;Peak
9799.840	48.3	V	100.0	-51.7	AVG	312	2.2	RB 1 MHz;VB 10 Hz;Peak
9799.820	56.2	V	70.0	-13.8	PK	312	2.2	RB 1 MHz;VB 3 MHz;Peak
power setting 24.5								
7310.220	46.7	V	54.0	-7.3	AVG	283	1.0	RB 1 MHz;VB 10 Hz;Peak
7314.600	58.2	V	74.0	-15.8	PK	283	1.0	RB 1 MHz;VB 3 MHz;Peak

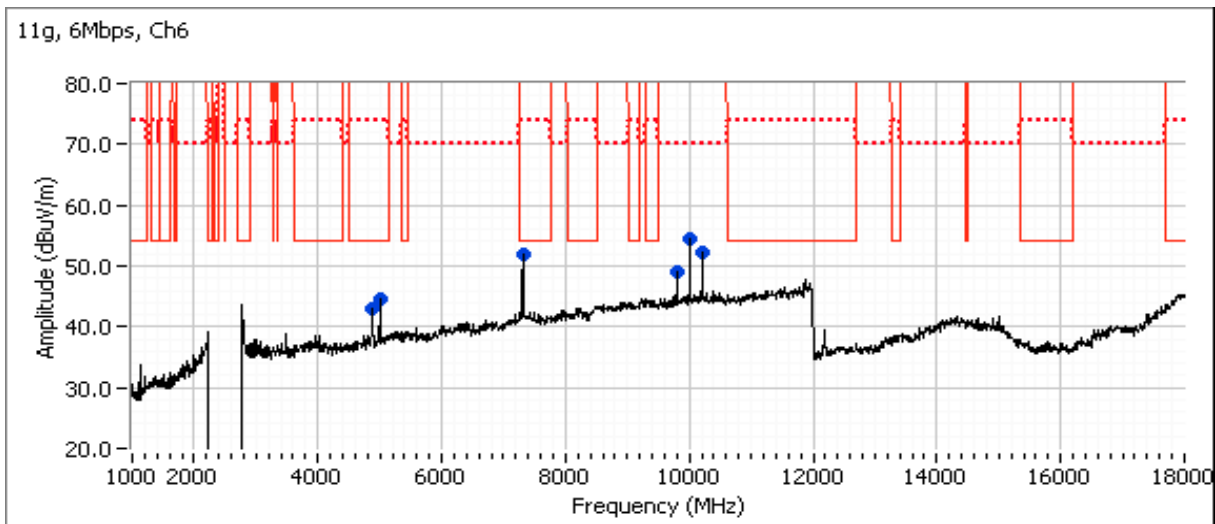

Note 1: Emissions were unrelated to radio. Final measurements were gathered under Run #1a.

Note: Scans made between 18 - 25 GHz with the measurement antenna moved around the card and its antennas 20-50cm from the device indicated there were no significant emissions in this frequency range



EMC Test Data

Client: Pace Americas, Inc.	Job Number: JD100298
Model: Wi-Fi Module 2.4 GHz	T-Log Number: T100355
Contact: Mark Rieger	Project Manager: Irene Radmacher
Standard: FCC Part 15.247	Project Coordinator: -
	Class: N/A

Run #2b: Center Channel

Channel: 6 Mode: n20 Setting: 24.5
 Tx Chain: 3x3 Data Rate: MCS 0

Frequency	Level	Pol	15.209 / 15.247		Detector	Azimuth	Height	Comments
MHz	dB μ V/m	v/h	Limit	Margin	PK/QP/Avg	degrees	meters	
7310.330	44.4	V	54.0	-9.6	AVG	287	1.0	RB 1 MHz;VB 10 Hz;Peak
7305.330	58.5	V	74.0	-15.5	PK	287	1.0	RB 1 MHz;VB 3 MHz;Peak
4873.730	34.5	V	54.0	-19.5	AVG	327	1.0	RB 1 MHz;VB 10 Hz;Peak
4877.400	46.1	V	74.0	-27.9	PK	327	1.0	RB 1 MHz;VB 3 MHz;Peak

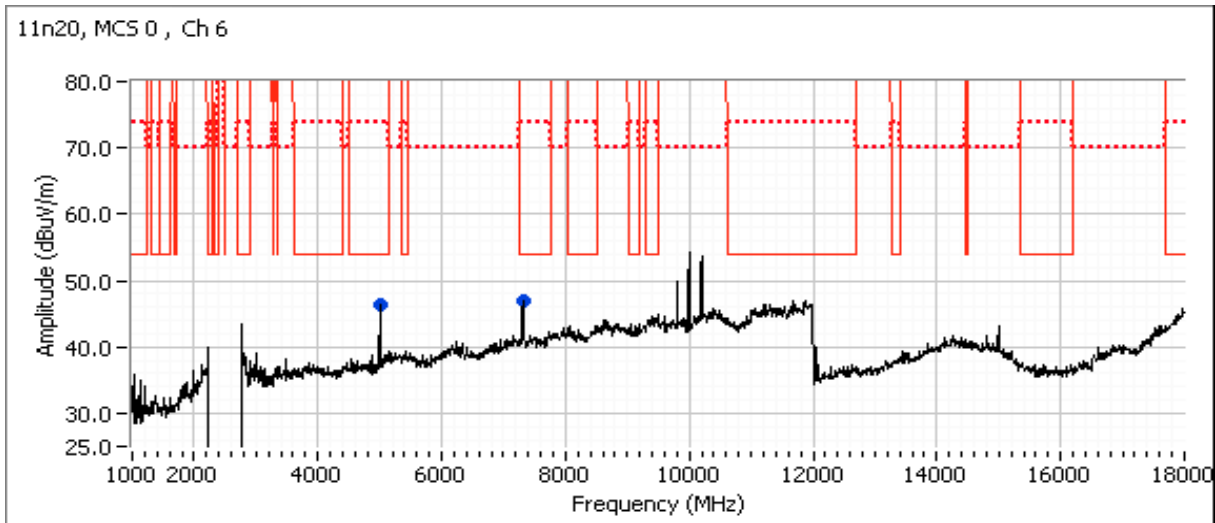

Note: Scans made between 18 - 25 GHz with the measurement antenna moved around the card and its antennas 20-50cm from the device indicated there were no significant emissions in this frequency range



EMC Test Data

Client: Pace Americas, Inc.	Job Number: JD100298
Model: Wi-Fi Module 2.4 GHz	T-Log Number: T100355
Contact: Mark Rieger	Project Manager: Irene Radamacher
Standard: FCC Part 15.247	Project Coordinator: -
	Class: N/A

Run #2c: Center Channel

Channel: 6 Mode: n40 Setting: 24.5
 Tx Chain: 3x3 Data Rate: MCS 0

Frequency	Level	Pol	15.209 / 15.247		Detector	Azimuth	Height	Comments
MHz	dB μ V/m	v/h	Limit	Margin	PK/QP/Avg	degrees	meters	
5000.000	46.5	V	54.0	-7.5	AVG	277	1.9	RB 1 MHz;VB 1 kHz;Peak
7325.300	40.8	V	54.0	-13.2	AVG	280	2.2	RB 1 MHz;VB 1 kHz;Peak
7320.300	52.3	V	74.0	-21.7	PK	280	2.2	RB 1 MHz;VB 3 MHz;Peak
4999.820	50.9	V	74.0	-23.1	PK	277	1.9	RB 1 MHz;VB 3 MHz;Peak

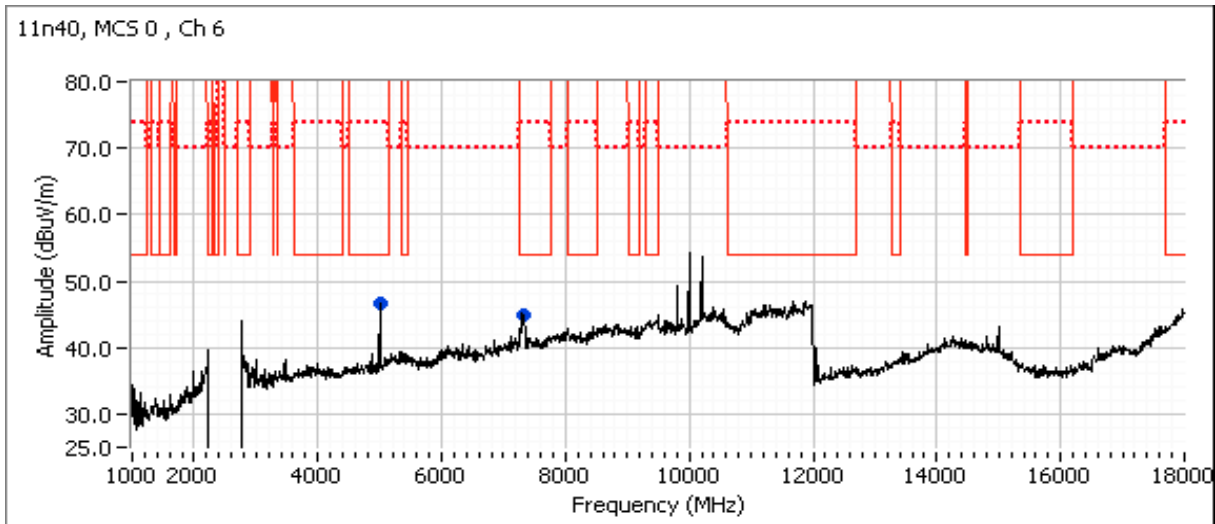

Note: Scans made between 18 - 25 GHz with the measurement antenna moved around the card and its antennas 20-50cm from the device indicated there were no significant emissions in this frequency range



EMC Test Data

Client: Pace Americas, Inc.	Job Number: JD100298
Model: Wi-Fi Module 2.4 GHz	T-Log Number: T100355
Contact: Mark Rieger	Project Manager: Irene Radmacher
Standard: FCC Part 15.247	Project Coordinator: -
	Class: N/A

Run #3: Radiated Spurious Emissions, 1,000 - 25000 MHz. Operating Mode: Worse case from Run #2

Date of Test: 01/06/16 Config. Used: 1
 Test Engineer: Mehran Birgani Config Change: None
 Test Location: FT Chamber#7 EUT Voltage: 120V/60Hz

Run #3a: Low Channel

Channel: 1 Mode: g Setting: 24.5
 Tx Chain: 3Tx Data Rate: 6 Mb/s

Frequency	Level	Pol	15.209 / 15.247		Detector	Azimuth	Height	Comments
MHz	dB μ V/m	v/h	Limit	Margin	Pk/QP/Avg	degrees	meters	
5000.030	45.1	V	54.0	-8.9	AVG	274	1.6	RB 1 MHz;VB 10 Hz;Peak
4999.870	50.7	V	74.0	-23.3	PK	274	1.6	RB 1 MHz;VB 3 MHz;Peak
7241.670	45.7	V	-	-	PK	285	1.6	

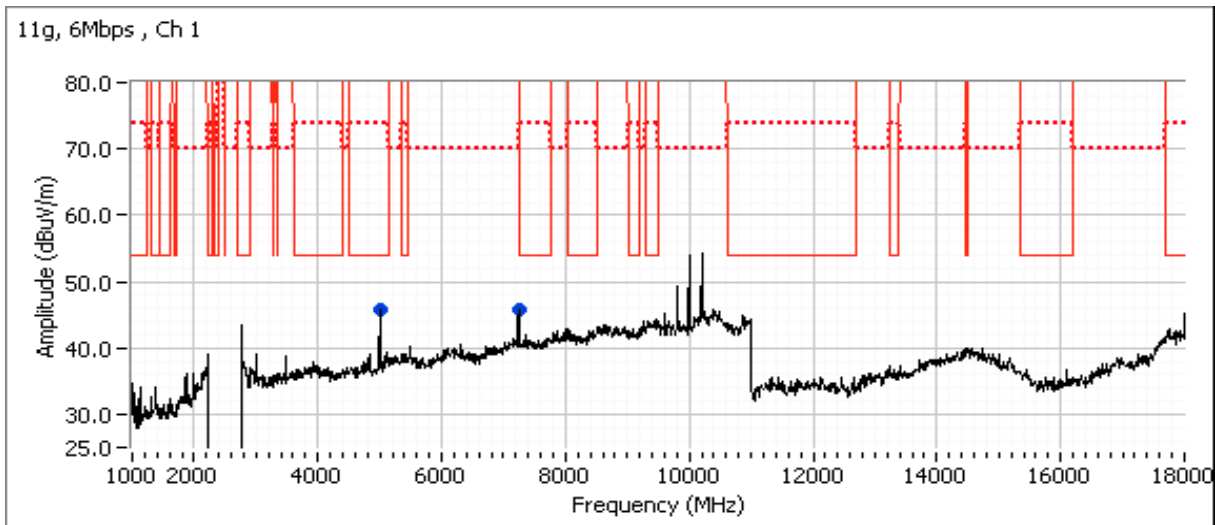

Note: Scans made between 18 - 25 GHz with the measurement antenna moved around the card and its antennas 20-50cm from the device indicated there were no significant emissions in this frequency range



EMC Test Data

Client: Pace Americas, Inc.	Job Number: JD100298
Model: Wi-Fi Module 2.4 GHz	T-Log Number: T100355
Contact: Mark Rieger	Project Manager: Irene Radamacher
Standard: FCC Part 15.247	Project Coordinator: -
	Class: N/A

Run #3b: High Channel

Channel: 11 Mode: g Setting: 24.5
 Tx Chain: 3Tx Data Rate: 6 Mb/s

Frequency	Level	Pol	15.209 / 15.247		Detector	Azimuth	Height	Comments
MHz	dB μ V/m	v/h	Limit	Margin	PK/QP/Avg	degrees	meters	
5000.000	44.4	V	54.0	-9.6	AVG	269	1.6	RB 1 MHz;VB 10 Hz;Peak
7389.570	42.4	V	54.0	-11.6	AVG	288	1.0	RB 1 MHz;VB 10 Hz;Peak
7389.170	55.8	V	74.0	-18.2	PK	288	1.0	RB 1 MHz;VB 3 MHz;Peak
4999.850	50.6	V	74.0	-23.4	PK	269	1.6	RB 1 MHz;VB 3 MHz;Peak

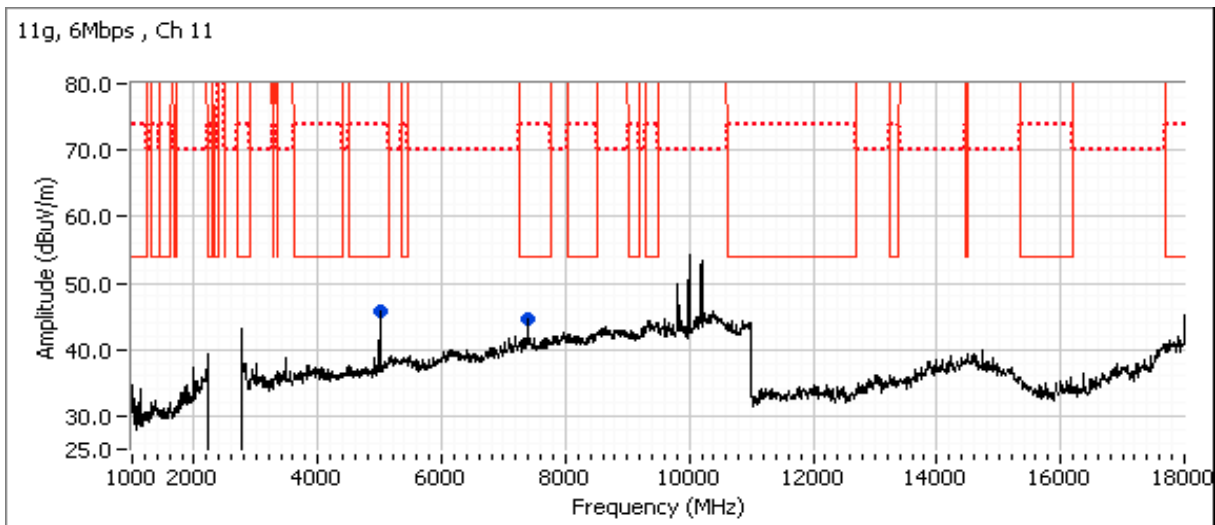

Note: Scans made between 18 - 25 GHz with the measurement antenna moved around the card and its antennas 20-50cm from the device indicated there were no significant emissions in this frequency range



EMC Test Data

Client: Pace Americas, Inc.	Job Number: JD100298
Model: Wi-Fi Module 2.4 GHz	T-Log Number: T100355
	Project Manager: Irene Radamacher
Contact: Mark Rieger	Project Coordinator: -
Standard: FCC Part 15.247	Class: N/A

RSS-247 and FCC 15.247 (DTS) Radiated Spurious Emissions

Test Specific Details

Objective: The objective of this test session is to perform final qualification testing of the EUT with respect to the specification listed above.

General Test Configuration

The EUT and all local support equipment were located on the turntable for radiated spurious emissions testing.

For radiated emissions testing the measurement antenna was located 3 meters from the EUT, unless otherwise noted.

Ambient Conditions:

Temperature: 15-17 °C
Rel. Humidity: 35-40 %

Summary of Results - Device Operating in the 2400-2483.5 MHz Band

Run #	Mode	Channel	Target Power	Power Setting	Test Performed	Limit	Result / Margin
1	b	1 - 2412MHz	26.0	26.0	Radiated Emissions, 30 - 1,000 MHz	FCC Part 15.209 / 15.247(c)	35.4 dBµV/m @ 874.99 MHz (-10.6 dB)
2	n20	11 - 2462MHz	24.5	24.5	Radiated Emissions, 30 - 1,000 MHz	FCC Part 15.209 / 15.247(c)	33.7 dBµV/m @ 30.27 MHz (-6.3 dB)

If no difference between modes and channels, then no additional modes or channels need be tested.

Modifications Made During Testing

No modifications were made to the EUT during testing

Deviations From The Standard

No deviations were made from the requirements of the standard.

Sample Notes

Sample S/N: F55154470184
Driver: 7.14.89.21.571.206
Antenna: 3 Tx (Non beamforming modes)

Procedure Comments:

Measurements performed in accordance with ANSI C63.10

Measurement Specific Notes:

Note 1:	Emission in non-restricted band, but limit of 15.209 used.
Note 2:	Emission in non-restricted band, the limit was set 30dB below the level of the fundamental and measured in 100kHz.



EMC Test Data

Client: Pace Americas, Inc.	Job Number: JD100298
Model: Wi-Fi Module 2.4 GHz	T-Log Number: T100355
Contact: Mark Rieger	Project Manager: Irene Radamacher
Standard: FCC Part 15.247	Project Coordinator: -
	Class: N/A

Run #1: Radiated Spurious Emissions, 30 - 1,000 MHz

Date of Test: 01/11/16
 Test Engineer: Mehran Birgani
 Test Location: Chamber #7
 Config. Used: 1
 Config Change: -
 EUT Voltage: 120V/60Hz

Channel: 1 Mode: b Setting: 26.0
 Tx Chain: 3Tx Data Rate: 2Mbps

Frequency	Level	Pol	15.209 / 15.247		Detector	Azimuth	Height	Comments
MHz	dB μ V/m	v/h	Limit	Margin	Pk/QP/Avg	degrees	meters	
874.990	35.4	H	46.0	-10.6	QP	81	1.0	QP (1.00s)
432.007	34.5	H	46.0	-11.5	QP	308	2.5	QP (1.00s)
46.683	27.2	V	40.0	-12.8	QP	7	1.0	QP (1.00s)
40.450	22.9	V	40.0	-17.1	QP	287	1.5	QP (1.00s)
356.653	28.4	H	46.0	-17.6	QP	247	1.5	QP (1.00s)
196.878	23.2	H	43.5	-20.3	QP	254	1.5	QP (1.00s)
138.707	13.7	H	43.5	-29.8	QP	22	1.0	QP (1.00s)

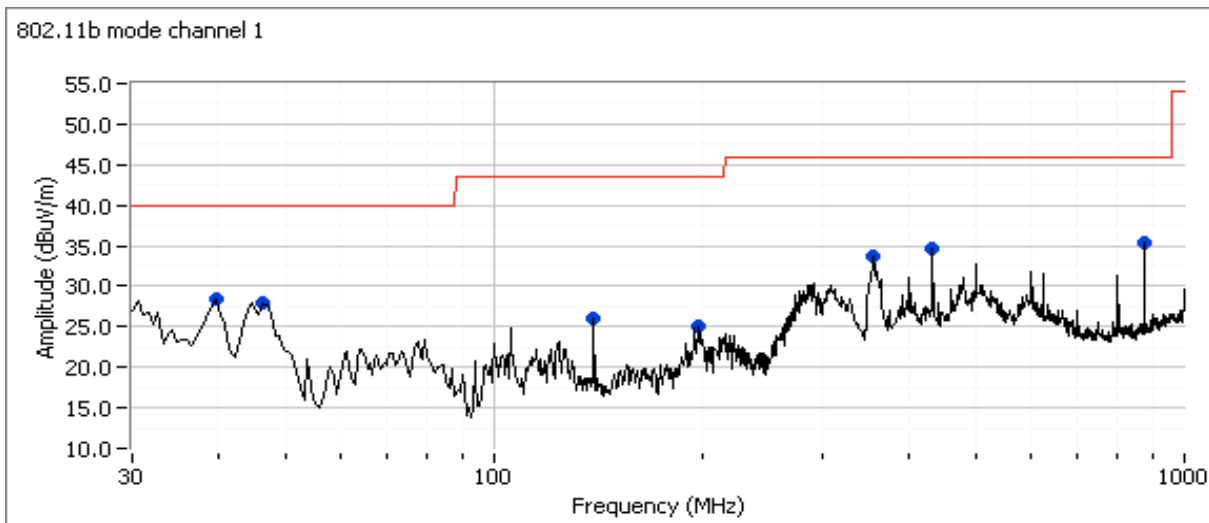



EMC Test Data

Client: Pace Americas, Inc.	Job Number: JD100298
Model: Wi-Fi Module 2.4 GHz	T-Log Number: T100355
	Project Manager: Irene Radamacher
Contact: Mark Rieger	Project Coordinator: -
Standard: FCC Part 15.247	Class: N/A

Run 2: Radiated Spurious Emissions, 30 - 1,000 MHz

Date of Test: 01/11/16

Config. Used: 1

Test Engineer: Mehran Birgani

Config Change: -

Test Location: Chamber #7

EUT Voltage: 120V/60Hz

Channel: 11 Mode: n20 Setting: 23.0
 Tx Chain: 3Tx Data Rate: MCS 0

Frequency	Level	Pol	15.209 / 15.247		Detector	Azimuth	Height	Comments
MHz	dB μ V/m	v/h	Limit	Margin	Pk/QP/Avg	degrees	meters	
30.269	33.7	H	40.0	-6.3	QP	219	1.5	QP (1.00s)
875.007	35.2	H	46.0	-10.8	QP	85	1.0	QP (1.00s)
432.007	34.2	H	46.0	-11.8	QP	319	2.0	QP (1.00s)
46.722	27.4	V	40.0	-12.6	QP	292	1.0	QP (1.00s)
499.998	33.4	H	46.0	-12.6	QP	314	2.0	QP (1.00s)
77.793	19.1	V	40.0	-20.9	QP	219	1.0	QP (1.00s)
196.652	20.9	H	43.5	-22.6	QP	231	2.0	QP (1.00s)

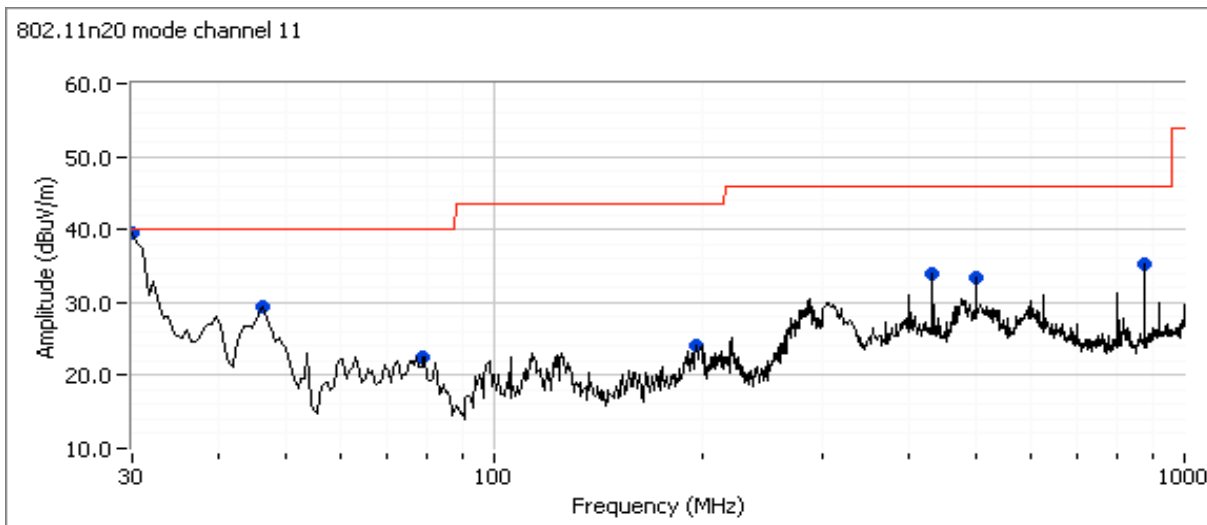



EMC Test Data

Client: Pace Americas, Inc.	Job Number: JD100298
Model: Wi-Fi Module 2.4 GHz	T-Log Number: T100355
	Project Manager: Irene Radamacher
Contact: Mark Rieger	Project Coordinator: -
Standard: FCC Part 15.247	Class: N/A

Conducted Emissions

(NTS Silicon Valley, Fremont Facility, Semi-Anechoic Chamber)

Test Specific Details

Objective: The objective of this test session is to perform final qualification testing of the EUT with respect to the specification listed above.

Date of Test: 1/11/2016	Config. Used: 1
Test Engineer: Mehran Birgani	Config Change: -
Test Location: Chamber #7	EUT Voltage: 120V/ 60Hz

General Test Configuration

The EUT and power source were located on a wooden table inside the semi-anechoic chamber, 40 cm from a vertical coupling plane and 80cm from the LISN. Remote support equipment was located outside of the semi-anechoic chamber. Any cables running to remote support equipment were routed through metal conduit and when possible passed through a ferrite clamp upon exiting the chamber.

Ambient Conditions:

Temperature:	17-19 °C
Rel. Humidity:	35-40 %

Summary of Results

Run #	Test Performed	Limit	Result	Margin
1	CE, AC Power, 120V/60Hz	FCC 15.207	Pass	39.4 dBµV @ 0.474 MHz (-7.0 dB)

Modifications Made During Testing

No modifications were made to the EUT during testing

Deviations From The Standard

No deviations were made from the requirements of the standard.

Client: Pace Americas, Inc.	Job Number: JD100298
Model: Wi-Fi Module 2.4 GHz	T-Log Number: T100355
Contact: Mark Rieger	Project Manager: Irene Radamacher
Standard: FCC Part 15.247	Project Coordinator: -
	Class: N/A

Run #1: AC Power Port Conducted Emissions, 0.15 - 30MHz, 120V/60Hz
 Mode: 802.11n 20MHz (MCS 0) Power Setting: 24.5
 Channel: 6 (2437 MHz)

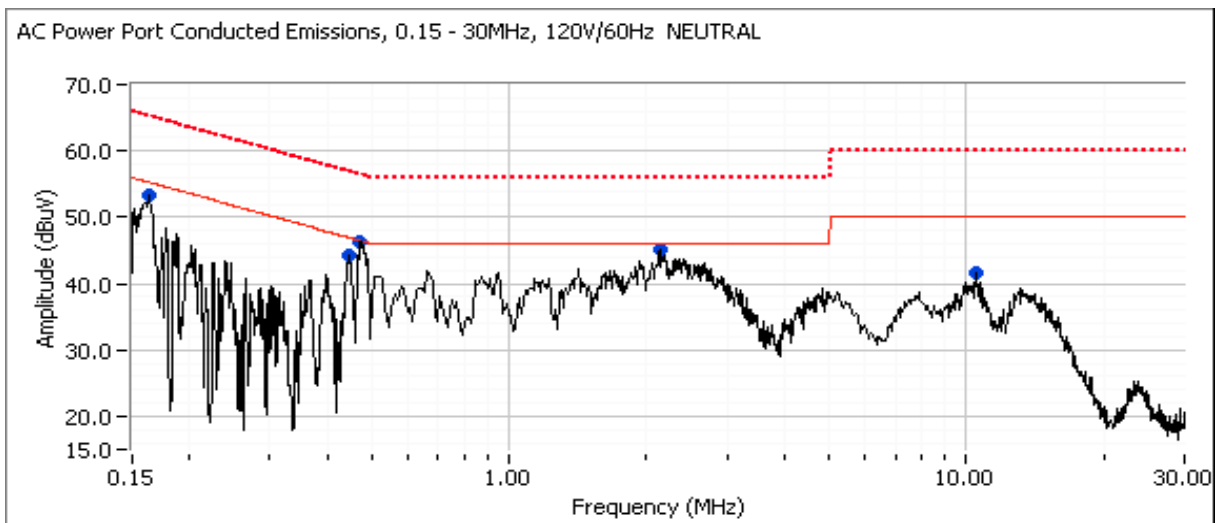
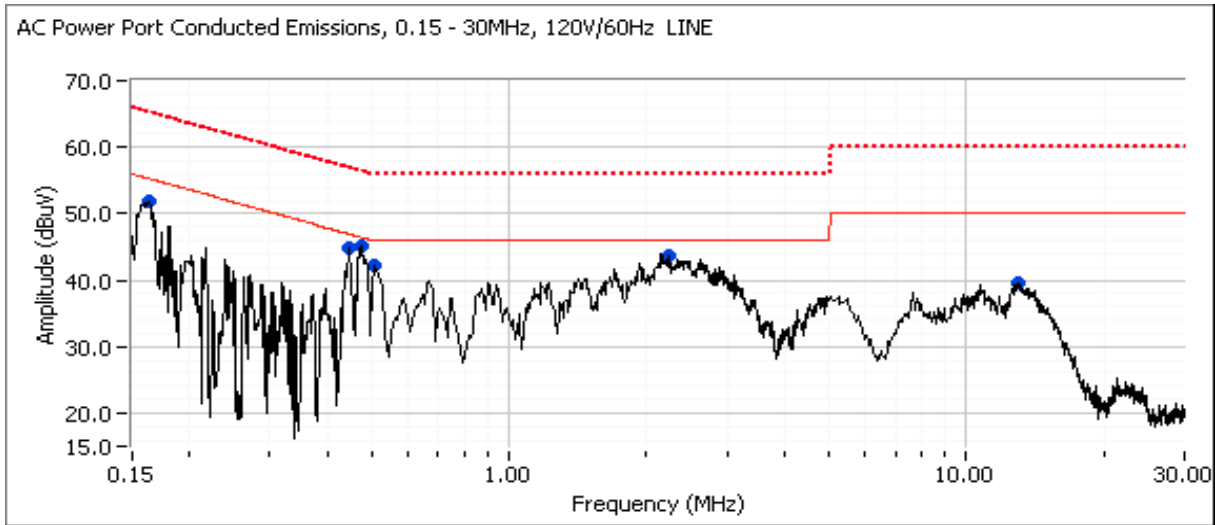



EMC Test Data

Client: Pace Americas, Inc.	Job Number: JD100298
Model: Wi-Fi Module 2.4 GHz	T-Log Number: T100355
	Project Manager: Irene Radamacher
Contact: Mark Rieger	Project Coordinator: -
Standard: FCC Part 15.247	Class: N/A

Run #1: AC Power Port Conducted Emissions, 0.15 - 30MHz, 120V/60Hz
Mode: 802.11n 20MHz (MCS 0) Power Setting: 24.5
Channel: 6 (2437 MHz)

Preliminary peak readings captured during pre-scan (peak readings vs. average limit)

Frequency MHz	Level dB μ V	AC Line	FCC 15.207		Detector QP/Ave	Comments
			Limit	Margin		
0.472	46.4	Neutral	46.5	-0.1	Peak	
2.124	45.1	Neutral	46.0	-0.9	Peak	
0.474	45.1	Line	46.4	-1.3	Peak	
0.162	53.3	Neutral	55.3	-2.0	Peak	
0.447	44.7	Line	46.9	-2.2	Peak	
2.227	43.8	Line	46.0	-2.2	Peak	
0.447	44.4	Neutral	47.0	-2.6	Peak	
0.163	51.8	Line	55.3	-3.5	Peak	
0.513	42.2	Line	46.0	-3.8	Peak	
10.451	41.6	Neutral	50.0	-8.4	Peak	
12.953	39.6	Line	50.0	-10.4	Peak	

Final quasi-peak and average readings

Frequency MHz	Level dB μ V	AC Line	FCC 15.207		Detector QP/Ave	Comments
			Limit	Margin		
0.474	39.4	Line	46.4	-7.0	AVG	AVG (0.10s)
0.472	38.6	Neutral	46.5	-7.9	AVG	AVG (0.10s)
0.162	45.9	Neutral	55.4	-9.5	AVG	AVG (0.10s)
2.124	36.2	Neutral	46.0	-9.8	AVG	AVG (0.10s)
0.472	46.3	Neutral	56.5	-10.2	QP	QP (1.00s)
0.513	35.5	Line	46.0	-10.5	AVG	AVG (0.10s)
0.163	44.7	Line	55.3	-10.6	AVG	AVG (0.10s)
0.474	45.0	Line	56.4	-11.4	QP	QP (1.00s)
0.447	35.3	Neutral	46.9	-11.6	AVG	AVG (0.10s)
2.227	34.3	Line	46.0	-11.7	AVG	AVG (0.10s)
0.447	35.0	Line	46.9	-11.9	AVG	AVG (0.10s)
0.447	43.4	Neutral	56.9	-13.5	QP	QP (1.00s)
0.447	43.2	Line	56.9	-13.7	QP	QP (1.00s)
0.513	42.1	Line	56.0	-13.9	QP	QP (1.00s)
2.124	41.9	Neutral	56.0	-14.1	QP	QP (1.00s)
0.162	50.6	Neutral	65.4	-14.8	QP	QP (1.00s)
0.163	49.9	Line	65.3	-15.4	QP	QP (1.00s)
2.227	40.2	Line	56.0	-15.8	QP	QP (1.00s)

End of Report

This page is intentionally blank and marks the last page of this test report.