

MPE/SAR/RF exposure information

This device was verified for RF exposure and found to comply with Council Recommendation 1999/519/EC and FCC OET-65 RF exposure requirements. This equipment complies with FCC radiation exposure limits set forth for an uncontrolled environment.

WARNING: While this device is in operation, a separation distance of at least 30 cm (12 inches) must be maintained between the radiating antenna inside the EUT and the bodies of all persons exposed to the transmitter to meet the FCC RF exposure guidelines.

Making changes to the antenna or the device is not permitted. Doing so may result in the installed system exceeding RF exposure requirements. This device must not be co-located or operated in conjunction with any other antenna or radio transmitter.

Cet appareil répond aux directives d'exposition RF 1999/519/EC et FCC OET-65 sur la limitation d'exposition du public général aux champs électromagnétiques.

MISE AN GARDE: Pour satisfaire aux exigences de la FCC et IC concernant l'exposition aux radiofréquences, une séparation de 30 cm ou plus doit être maintenue entre cet appareil et des personnes lors de fonctionnement du dispositif. Pour assurer la conformité, des opérations au plus près que cette distance n'est pas recommandée.

L'antenne utilisée pour cet émetteur ne doit pas être co-localisée ou fonctionner conjointement avec une autre antenne ou transmetteur.

Safety information

The following sections describe the safety guidelines for this product.

AC adapter

This product is intended to be supplied with a listed ARRIS desktop AC adapter marked Class 2 or LPS and rated 100 – 120V, 50/60Hz 1A, Output 12V, 3.75A for all NVG5X8 series gateway models.

The AC power adapter supplied with this product is designed to ensure your personal safety and to be compatible with this equipment. Use only the power adapter that was provided with the gateway.

Please follow these guidelines:

- Do not use the adapter in a high moisture environment. Never touch the adapter when your hands or feet are wet.
- Allow adequate ventilation around the adapter. Avoid locations with restricted airflow.
- Connect the adapter to a proper power source. The voltage and grounding requirements are found on the product case and/or packaging.

Adaptateur secteur

Cet appareil est destiné à être alimenté par une source d'alimentation directe fournie par ARRIS ou 2Wire, de « Classe 2 » ou marquée « LPS », et avec un courant de sortie de 100 – 120V, 50/60Hz 3.75A pour tous les modèles NVG5X8.

Le bloc d'alimentation secteur fourni avec ce produit a été conçu pour garantir votre sécurité et être compatible avec cet appareil.

Veillez suivre les consignes suivantes:

- N'utilisez pas l'adaptateur secteur dans un environnement hautement humide. Ne touchez jamais l'adaptateur secteur si vos pieds ou mains sont humides.
- Laissez une ventilation adéquate autour de l'adaptateur secteur. Evitez les endroits où la circulation de l'air est insuffisante.
- Branchez l'adaptateur secteur sur une prise respectant les spécifications sur la tension et la mise à la terre se trouvant sur la coque et/ou l'emballage du produit.

Telecommunication cord Caution: To reduce the risk of fire, use only No. 26 AWG or larger UL Listed or CSA Certified Telecommunication Line Cord.

Cordon téléphonique Attention: Afin de réduire le risque d'incendie, n'utilisez qu'un cordon téléphonique de calibre 26 AWG ou supérieur listé UL ou certifié CSA.

Internal telephone ports (VoIP)

Telecommunication equipment connected to this port (e.g., via "Phone Lines 1 & 2" port) should be UL Listed and the connections shall be made in accordance with Article 800 of the NEC.

Port téléphonique (VoIP)

Tout équipement de télécommunication téléphonique connecté à ce port doit être listé UL et les branchements doivent être fait conformément aux dispositions de l'Article 800 du Code national de l'électricité (NEC).

Repairs

Do not, under any circumstances, attempt any service, adjustments, or repairs on this equipment. Instead, contact your local ARRIS distributor or service provider for assistance. Failure to comply may void the product warranty.

Réparations

N'essayez en aucun cas d'effectuer des réparations, des ajustements ou des réparations sur cet équipement. Contactez plutôt votre distributeur ou fournisseur de services ARRIS local pour obtenir de l'aide. Le non-respect de cette consigne peut annuler la garantie du produit.

Location - electrical considerations

CAUTION: Due to risk of electrical shock or damage, do not use this product near water, including a bathtub, wash bowl, kitchen sink or laundry tub, in a wet basement, or near a swimming pool. Also, avoid using this product during electrical storms. Avoid locations near electrical appliances or other devices that cause excessive voltage fluctuations or emit electrical noise (for example, air conditioners, neon signs, high-frequency or magnetic security devices, or electric motors).

Emplacement – Considération électriques

AVERTISSEMENT: Pour éviter un risque de choc électrique, n'utilisez pas cet appareil à proximité d'une source d'eau, par exemple près d'une baignoire, un lavabo, une machine à laver, dans un garage humide ou près d'une piscine. Evitez aussi d'utiliser cet appareil durant un orage. Evitez de brancher cet appareil à proximité d'appareils électriques pouvant causer de large fluctuations de tension ou émettant du bruit électrique (tel que climatiseurs, enseignes au néon, dispositifs de sécurité magnétique ou de haute-fréquence, ou moteurs électriques).

Location - environmental considerations

Do not plug the power adapter into an outdoor outlet or operate the residential gateway outdoors. It is not waterproof or dustproof, and is for indoor use only. Any damage to the unit from exposure to rain or dust may void your warranty.

Do not use the residential gateway where there is high heat, dust, humidity, moisture, or caustic chemicals or oils.

Keep the gateway away from direct sunlight and anything that radiates heat, such as a stove or a motor.

- Do not use the adapter if the cord becomes damaged.
- Do not attempt to service the adapter. There are no serviceable parts inside. Replace the unit if it is damaged or exposed to excess moisture.

Lieu - considérations environnementales

Ne branchez pas l'adaptateur secteur sur une prise extérieure et n'utilisez pas la passerelle résidentielle à l'extérieur. Il n'est pas étanche à l'eau ou à la poussière, et est pour une utilisation à l'intérieur seulement. Tout dommage à l'appareil résultant d'une exposition à la pluie ou à la poussière peut annuler votre garantie. N'utilisez pas la passerelle résidentielle dans des endroits où la chaleur, la poussière, l'humidité, des produits chimiques ou des huiles sont caustiques. Gardez la passerelle à l'abri de la lumière directe du soleil et de tout ce qui dégage de la chaleur, tel qu'un poêle ou un moteur.

- N'utilisez pas l'adaptateur si le cordon est endommagé.
- N'essayez pas de réparer l'adaptateur. Il n'y a aucune pièce réparable à l'intérieur. Remplacez l'appareil s'il est endommagé ou exposé à un excès d'humidité.

Class 1M Laser Product

DANGER: Viewing the laser output with certain optical instruments (e.g. eye loupes, magnifiers and microscopes) within a distance of 100 mm may pose an eye hazard.

DANGER: Use of controls or adjustments, or performance of procedures other than those specified herein may result in hazardous radiation exposure.

DANGER: There must be a proper termination of all active fibers in the network.

IEC 60825-1:2014- Safety of laser products- Equipment classification and requirements
EN 60825-1:2014- Safety of laser products- Equipment classification and requirements

IEC 60825-2:2004+A1+A2- Safety of laser products- Safety of OFCS

EN 60825-2:2004+A1+A2- Safety of laser products- Safety of OFCS
Complies with 21 CFR 1040.10 and 1040.11 except for deviations pursuant to Laser Notice

No. 50, dated June 24, 2007

Produit laser de classe 1M

DANGER: La visualisation de la sortie laser avec certains instruments optiques (loupes, loupes et microscopes, par exemple) à une distance de 100 mm peut présenter un risque pour les yeux.

DANGER: L'utilisation de commandes ou de réglages, ou l'exécution de procédures autres que celles spécifiées dans le présent document peut entraîner une exposition à un rayonnement dangereux.

DANGER: toutes les fibres actives du réseau doivent être correctement terminées

IEC 60825-1: 2014- Sécurité des produits à laser- Classification et exigences de l'équipement

EN 60825-1: 2014- Sécurité des produits à laser- Classification et exigences de l'équipement

IEC 60825-2: 2004 + A1 + A2- Sécurité des produits laser- Sécurité des systèmes OFCS
EN 60825-2: 2004 + A1 + A2- Sécurité des produits laser- Sécurité des systèmes OFCS

Conforme aux normes 21 CFR 1040.10 et 1040.11 à l'exception des déviations par rapport à l'avis laser No 50, daté du 24 juin 2007.

Trade Name	ARRIS
Responsible Party	ARRIS International plc.
Address	3871 Lakefield Drive, Suwanee, GA 30024, United States
Phone	1-866 362-7747

CBRS

Part 96.35 General authorized access use.

(a) General Authorized Access Users shall be permitted to use frequencies assigned to PALs when such frequencies are not in use, as determined by the SAS, consistent with §96.25(c).

(b) Frequencies that are available for General Authorized Access Use shall be made available on a shared basis.

(c) General Authorized Access Users shall have no expectation of interference protection from other General Authorized Access Users operating in accordance with this part.

(d) General Authorized Access Users must not cause harmful interference to and must accept interference from Priority Access Licensees and Incumbent Users in accordance with this part.

(e) General Authorized Access Users operating Category B CBSDs must make every effort to cooperate in the selection and use of available frequencies provided by an SAS to minimize the potential for interference and make the most effective use of the authorized facilities. Such users shall coordinate with an SAS before seeking station authorization, and make every effort to ensure that their CBSDs operate at a location, and with technical parameters, that will minimize the potential to cause and receive interference among CBSDs. Operators of CBSDs suffering from or causing harmful interference are expected to cooperate and resolve interference problems through technological solutions or by other mutually satisfactory arrangements.

NVG5X8 Gateway Quick Start Guide

Introduction

Use this Quick Start Guide to install, configure, and perform basic troubleshooting for the NVG558 and NVG578S gateways.

Power supply installation

Connect the power supply cord to the Power In connector on the gateway and the other end into an appropriate electrical outlet.



Product ventilation

The gateway is intended for residential use. Position the gateway in a vertical position and where temperature remains within a range of 32° – 104°F (0° – 40°C) and heat from the unit itself is not trapped.

There must be at least two inches (2") of clearance on all sides except the bottom.

Inserting your SIM card

Before inserting a SIM card into the gateway, ensure the SIM card is flat & the central part of the card is present and securely attached to the SIM frame.

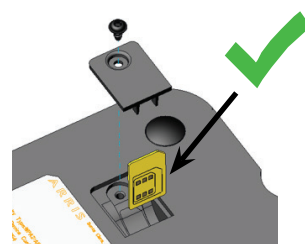

Never insert a SIM card frame into the unit without the central SIM card present and securely attached to the outer SIM frame. Doing so will lock the SIM frame inside the unit preventing its removal.

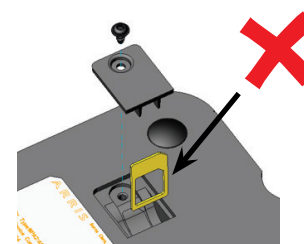

Gateway positioning, status indicator lights and port configuration

Proper positioning of the gateway is essential for proper cooling.

Colored LEDs on the gateway indicate the status of various port activity.

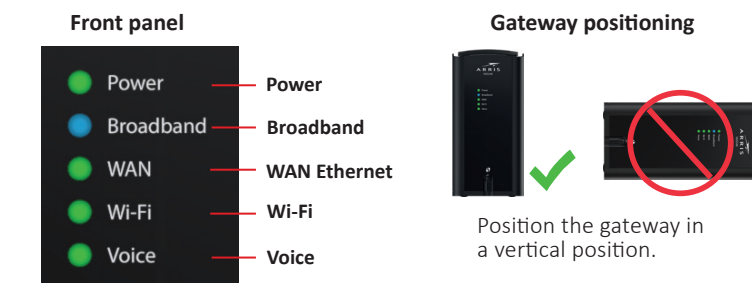

NVG558

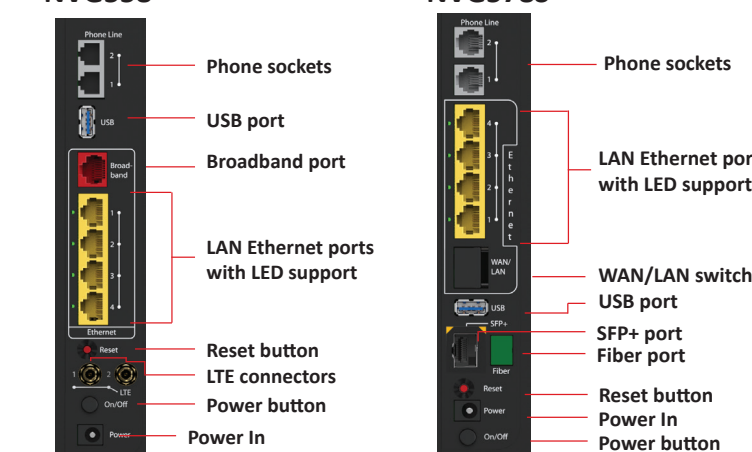

NVG578S

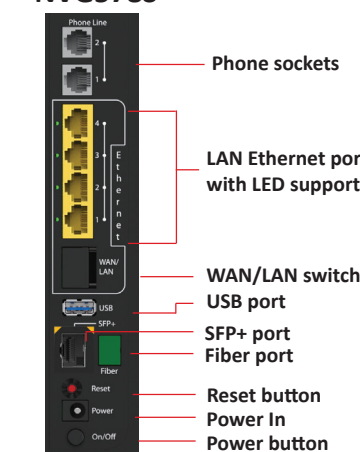

LED descriptions

LED	Status										
Power	<p>Solid Green: The device is powered on.</p> <p>Flashing Green: The device is starting.</p> <p>Solid Red: Boot failure.</p> <p>Flashing Red: Detecting factory reset (press and hold the recessed Reset button for 10 or more seconds to trigger the factory reset).</p>										
Broadband	<p>Solid Blue: Broadband internet connection is active.</p> <p>Solid Red: No IP address or authentication failed.</p> <p>Off: No active broadband connection.</p>										
WAN	<table border="1"> <tr> <td>NVG578S/NVG558 (with Ethernet WAN interface)</td> <td>NVG558 (with Cellular WAN interface)</td> </tr> <tr> <td>Solid Green: Ethernet WAN connection is good.</td> <td>Solid Green: Cellular WAN connection is good.</td> </tr> <tr> <td>Flashing Green: Trying to connect to the available network.</td> <td>Solid Yellow: Cellular WAN connection is fair.</td> </tr> <tr> <td>Solid Red: No Ethernet WAN connection on the line.</td> <td>Solid Red: Cellular WAN connection is poor.</td> </tr> <tr> <td></td> <td>Flashing Red: No cellular WAN connection on the line.</td> </tr> </table>	NVG578S/NVG558 (with Ethernet WAN interface)	NVG558 (with Cellular WAN interface)	Solid Green: Ethernet WAN connection is good.	Solid Green: Cellular WAN connection is good.	Flashing Green: Trying to connect to the available network.	Solid Yellow: Cellular WAN connection is fair.	Solid Red: No Ethernet WAN connection on the line.	Solid Red: Cellular WAN connection is poor.		Flashing Red: No cellular WAN connection on the line.
NVG578S/NVG558 (with Ethernet WAN interface)	NVG558 (with Cellular WAN interface)										
Solid Green: Ethernet WAN connection is good.	Solid Green: Cellular WAN connection is good.										
Flashing Green: Trying to connect to the available network.	Solid Yellow: Cellular WAN connection is fair.										
Solid Red: No Ethernet WAN connection on the line.	Solid Red: Cellular WAN connection is poor.										
	Flashing Red: No cellular WAN connection on the line.										
Wi-Fi	<p>Solid Green: Wireless enabled (either radio).</p> <p>Flashing Yellow: Wi-Fi protected Set-up (WPS) is active.</p> <p>Flashing Red: Flashes for 30 seconds to indicate the timeout or conflict of WPS.</p> <p>Solid Red: Wireless network failure.</p> <p>Off: Wireless is disabled for both the radios.</p>										
Voice	<p>Solid Green: All voice lines are registered and active.</p> <p>Flashing Green: A voice line is ringing or off-hook.</p> <p>Solid Yellow: Both lines of a two line system are provisioned with one unregistered.</p> <p>Flashing Yellow: Both lines of a two line system are provisioned with one registered and ringing or off hook and the other one unregistered.</p> <p>Solid Red: All provision voice lines are provisioned but not SIP registered.</p> <p>Off: VoIP is not provisioned or the gateway is turned off.</p>										
LAN/WAN Ethernet LEDs on rear panel RJ-45 ports	<p>Solid Green: Port is active.</p> <p>Off: Port is not active.</p> <p>Flashing Green: Traffic is passing on the line.</p>										



Powering and initial cabling

Press the **Power** button on the back of the gateway. The Power indicator will initially flash GREEN to indicate that the gateway is booting and then solid GREEN to indicate it is operational. Under normal operation, while the gateway is powering up, LED status is as follows:

- Broadband, WAN Ethernet, Wi-Fi and and Voice indicators will be off.
- Broadband indicator will initially be solid RED, and upon Ethernet link, it will light solid BLUE.
- Phone indicator will light solid GREEN after the Broadband indicator lights BLUE to indicate that digital phone service is active.
- Wireless indicator will light solid GREEN to indicate that the Wireless service is enabled.

NOTE: During the initial setup, it may take several minutes to achieve service connectivity.

Broadband: Follow instructions provided by your Service Provider. If no instructions are provided, then call your Service Provider.

Digital Phone Service: To connect the gateway to a digital phone line:

1. Connect the supplied RJ-11 terminated phone cable to the Phone port on the back of the gateway.
2. Connect the phone cable to a phone or fax machine.

LAN Ethernet: To make an Ethernet connection:

1. Connect the supplied RJ-45 terminated Ethernet cable to one of the Ethernet ports on the back of the gateway.
2. Connect the Ethernet cable to the Ethernet port on a local computer.

USB port: To connect the gateway to the USB port:

1. Connect the USB cable to the USB port on the back of the gateway.
2. Connect the other end of the USB cable to your device.

Access the Web Management Interface

1. Open a web browser, such as Firefox, Chrome, or Microsoft Internet Explorer, from the computer connected to the gateway.
2. Type the following address in the address bar of the browser to open the Access Code Required Screen:

http://192.168.1.254

NOTE: Select the appropriate language button in the lower right corner of the Access Code Required screen to continue with the selected language.

1. Provide the Device Access Code, a unique code printed on a label on the base of the gateway.
2. Select **Continue**.

To access the Web Management configuration pages:

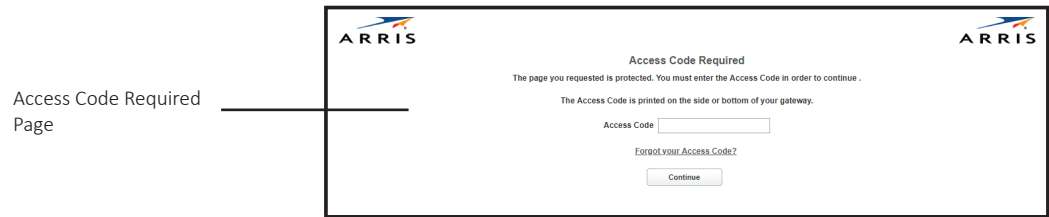

NOTE: The terms Device Access Code and Password are sometimes used interchangeably.

Add a wireless device to the gateway

On the wireless device, use the Wireless setup option to find the available wireless network names. The Wi-Fi Network Name for the gateway is printed on the bottom of the label along with the Wi-Fi password.

NOTE: The main page provides an overview about the connection and home network status. You can also access information for the following:

- **Home:** Network Status/Configuration
- **System:** System status, upgrade, restart and factory reset options
- **Broadband:** WAN status, statistics, and parameter settings
- **Wi-Fi:** Wi-Fi status and configuration
- **Voice:** Voice status and QoS configuration
- **Home Network:** LAN status and configuration
- **Firewall:** Firewall status/configuration
- **Diagnostics:** Gateway connection and application diagnostics

Radio Band	Radio Status	SSID Type	SSID State	Network Name (SSID)	Password
2.4 GHz	operational	Primary	On	ARRIS001E (Broadcast)	WPA: vtf8pr7wq58k
		Guest	Off	Guest001E (Broadcast)	WPA: 1804289383
5.0 GHz	operational	Primary	On	ARRIS001E (Broadcast)	WPA: vtf8pr7wq58k
		Guest	Off	Guest001E (Broadcast)	WPA: 1804289383

Image: Home page

NOTE: This is a reference image and may slightly differ based on your device.

Declaration of conformity

The following sections describe regulatory compliance by region.

FCC/ISED compliance

This device has been tested and certified as compliant with the regulations and guidelines set forth in the Federal Communication Commission- FCC Title 47 Part 15 and the Innovation Science and Economic Development (ISED) Canada CAN ICES-3 (B)/NMB-3(B) and RSS-247 Radio and Telecommunication regulatory requirements.

Cet appareil a été testé et certifié conforme aux réglementations et directives définies dans les exigences réglementaires CAN CAN ICES-3 (B) / NMB-3 (B) et RSS-247 d’Innovation et Canada (ISED).

Manufacturer: ARRIS

Models: NVG558H, NVG558CH

Part 15 of FCC rules

This device complies with part 15 of the FCC Rules and Industry Canada license- exempt RSS standard(s). Operation is subject to the following two conditions:

(1) this device may not cause harmful interference, and (2) this device must accept any interference received, including interference that may cause undesired operation of the device.

Le présent appareil est conforme aux normes CNR d’Industrie Canada applicables aux appareils radio exempts de licence. L’exploitation est autorisée aux deux conditions suivantes:

1. l’appareil ne doit pas produire de brouillage, et
2. l’utilisateur de l’appareil doit accepter tout brouillage radioélectrique subi, même si le brouillage est susceptible d’en compromettre le fonctionnement.

The device could automatically discontinue transmission in case of absence of information to transmit, or operational failure. Note that this is not intended to prohibit transmission of control or signaling information or the use of repetitive codes where required by the technology.

The device for operation in the band 5150–5250 MHz is only for indoor use to reduce the potential for harmful interference to co-channel mobile satellite systems.

L’appareil peut interrompre automatiquement la transmission en cas d’absence d’informations à transmettre ou de panne opérationnelle. Notez que ceci n’est pas destiné à interdire la transmission d’informations de contrôle ou de signalisation ou l’utilisation de

codes répétitifs lorsque cela est requis par la technologie.

Le dispositif utilisé dans la bande 5150-5250 MHz est réservé à une utilisation en intérieur afin de réduire le risque de brouillage préjudiciable aux systèmes mobiles par satellite dans le même canal.

Les dispositifs fonctionnant dans la bande 5150-5250 MHz sont réservés uniquement pour une utilisation à l’intérieur afin de réduire les risques de brouillage préjudiciable aux systèmes de satellites mobiles utilisant les mêmes canaux.

This equipment has been tested and found to comply with the limits for a Class B digital device, pursuant to part 15 of the FCC Rules. These limits are designed to provide reasonable protection against harmful interference in a residential installation. This equipment generates, uses and can radiate radio frequency energy and, if not installed and used in accordance with the instructions, may cause harmful interference to radio communications. However, there is no guarantee that interference will not occur in a particular installation. If this equipment does cause harmful interference to radio or television reception, which can be determined by turning the equipment off and on, the user is encouraged to try to correct the interference by one or more of the following measures:

- Reorient or relocate the receiving antenna.
 - Increase the separation between the equipment and receiver.
 - Connect the equipment to an outlet on a circuit different from that to which the receiver is connected.
 - Consult the dealer or an experienced radio/TV technician for help.
- Caution:** Changes or modifications not expressly approved by the party responsible for compliance could void your authority to operate this equipment.

This radio transmitter 3439B-NVG5XDBAC has been approved by Innovation, Science and Economic Development Canada to operate with the antenna types listed below, with the maximum permissible gain indicated. Antenna types not included in this list that have a gain greater than the maximum gain indicated for any type listed are strictly prohibited for use with this device.

Cet émetteur radio 3439B-NVG5XDBAC a été approuvé par Innovation, Sciences et Développement économique Canada pour fonctionner avec les types d’antenne énumérés ci-dessous, avec le gain maximal autorisé indiqué. Les types d’antenne non inclus dans cette liste et dont le gain est supérieur au gain maximal indiqué pour l’un des types répertoriés ne sont strictement pas autorisés pour une utilisation avec cet appareil.