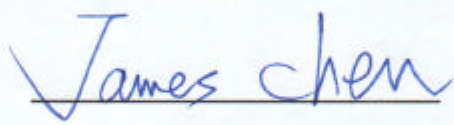
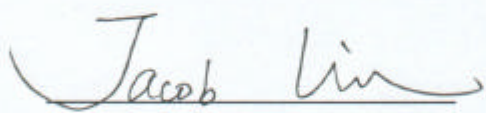

***EXHIBIT B***  
***Test Report***

Report No.	U1215628
FCC ID	PGCAD-1130
Specifications	FCC Part 15
Test Method	ANSI C63.4 1992
Applicant	UAT Inc.
Applicant Address	2F, No. 5, Alley22, Lane513, Jui Kuang Rd, Nei Hu, Taipei, Taiwan, 114
Items tested	USB ADSL Modem
Model No.	AD-1130 (Sample # U12628)
Results	<b>Compliance</b> (As detailed within this report)
Date	01/08/2001 (month / day / year)(Sample received) 01/08/2000 (month / day / year)(Tested)
Prepared by	 Project Engineer
Authorized by	 V.General Manager (Jacob Lin)
Issue date	Jan. 17, 2001 (month / day / year)
Modifications	None
Tested by	Training Research Co., Ltd.
Office at	2, Lane 194, Huan-Ho Street, Hsichih, Taipei Hsien 221, Taiwan
Open site at	No. 15, Lane 530, Pa-Lian RD., Sec. 1, Hsichih City, Taipei Hsien, Taiwan, R.O.C..

**Conditions of issue :**

- (1) This test report shall not be reproduced except in full, without written approval of TRC. And the test result contained within this report only relate to the sample submitted for testing.
- (2) This report must not be used by the client to claim product endorsement by NVLAP or any agency of U.S. Government.
- (3) This test report, measurements made by TRC are traceable to the NIST only Conducted and Radiated Method.

★ NVLAP LAB CODE: 200174-0

# Contents

## **Chapter 1 Introduction**

Description of EUT .....	3
Configuration of Test Setup .....	4
List of Support Equipment .....	5

## **Chapter 2 Conducted Emission Test**

Test Condition and Setup .....	7
Conducted Test Placement .....	8

## **Chapter 3 Radiated Emission Test**

Test Condition and Setup .....	9
Radiated Test Placement .....	10

## **Appendix A :**

Conducted test result .....	11
-----------------------------	----

## **Appendix B :**

Radiated test result .....	12
----------------------------	----

## ***Chapter 1 Introduction***

### ***Description of EUT:***

The EUT contains a complete evaluation package including hardware reference design, Windows software drivers, test/utility software, design documents.

The ADI ADSL USB Modem features:

- Plug and Play USB 1.1 specification interface
- Rate Adaptive ADSL technology that adapts to your phone line conditions
- Receive line rate up to 10Mbps (downstream) and transmit line rate up to 1Mbps(upstream).

### ***Test method:***

***The applicant provides the testing program.***

Pretest was found that the emission of operating mode is worse than standby mode. So, The final test is made at the operating mode.

During the pretest, the following mode was “link” mode that was the worst case.

The test placement as the photographs showed is the worst case emission placed. (If the emission is close to the ambient, the resolution BW and view resolution will be reduced and the data will be recorded by detection of maximum hold peak mode.)

***The testing configuration of test setup is showing in the next page.***

**Configuration of test setup**

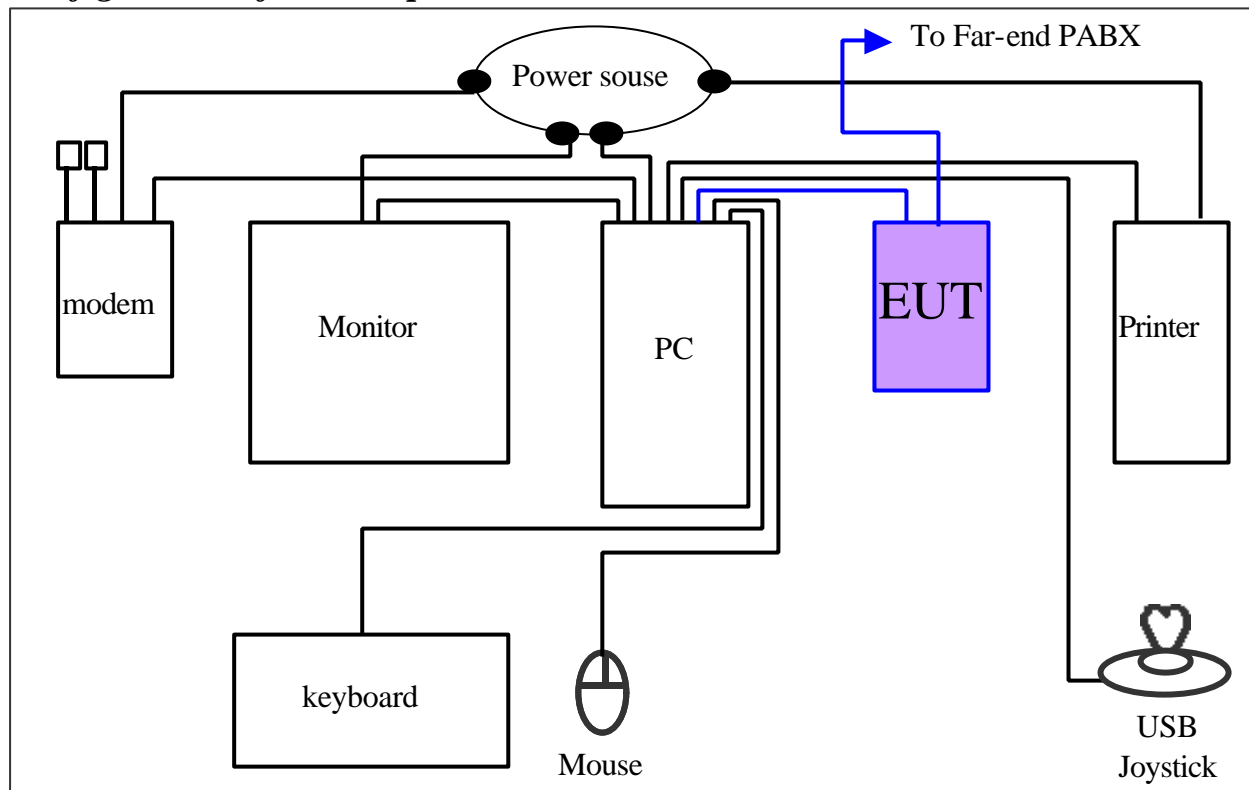

**Connections:**

**PC:**

- \*Power port --- via a 185cm long, non-shield, no ferrite bead, power cable to the AC power source.
  - \*Serial port --- via a 76cm shielded RS-232 cable to an external modem.
  - \*Printer port --- a printer with 1.80m length data cable.
  - \*Monitor port --- a monitor with 1.80m long of data cable.
  - \*Keyboard port --- a keyboard with 1.50m length data cable.
  - \*Mouse port --- a mouse with 1.50m length data cable.
  - \*USB port A --- a joystick with 1.50m long, shielded and no ferrite bead data cable.
  - \*USB port B --- to EUT.
- (Each port on PC is connected with suitable device)

**EUT:**

- \*USB port --- via a 1.50m long, shielded and no ferrite bead data cable to the USB port B of PC.
- \*Line port -- via a 30m long, non-shielded, no ferrite core, RJ11 cable to the line jack of Far-end PABX.

**List of support equipment**

**Conducted test:**

**PC** : **HP Brio 85xx 6/350**  
Model No. : D6928A  
Serial No. : SG91801432  
FCC ID : N/A  
檢磁 : 3872H013  
Power type : 100 ~ 230VAC / 50 ~ 60Hz, 5A, Switching  
Power cord : Non-shielded, 2.33m long, Plastic, No ferrite core

**Monitor** : **HP**  
Model No. : D2821  
Serial No. : TW 73512262  
FCC ID : A3KMO64  
Power type : AC 110~120 / 220~240 VAC, Switching  
Power cord : Non-Shielded, 3m long, no ferrite core  
Data cable : Shielded, 1.8m long, with ferrite core

**Keyboard** : **Digital**  
Model No. : KB-5923  
Serial No. : 9S74904837  
FCC ID : E8HKB-5923  
Power type : By PC  
Data cable : Shielded, 1.8m long, with ferrite core

**Mouse** : **HP**  
Model No. : M-S34  
Serial No. : LZB90714106  
FCC ID : DZL211029  
檢磁 : 4862A011  
Power type : By PC  
Power cord : Non-shielded, 1.88m long, No ferrite core

**Modem** : **ACEEX**  
Model No. : XDM-9624  
FCC ID : IFAXDM-9624  
Power type : 220VAC, 50Hz / 9VAC, 1A  
Power cord : Non-shielded, 1.9m long, No ferrite cord  
Data cable : RS232, Shielded, 1.2m long, No ferrite core  
RJ11C x 2, 7' long non-shielded, No ferrite core

**Printer** : **HP**  
Model No. : C2642A  
Serial No. : SG69A196GV  
FCC ID : B94C2642X  
Power type : 220VAC, 50Hz  
Power cord : Non-shielded, 2m long, no ferrite core  
Data cable : Shielded, 1.84m long, no ferrite core (1.7m)

**USB Joystick** : **Padix**  
Model No. : QF-606U, QF-707U  
Serial No. : N/A, 8100848  
FCC ID : N/A, Doc Approval  
Power type : Powered by PC  
Power Cable : Shielded, 1.5M long, No ferrite bead data cable

**Joystick** : **Logitech**  
Model No. : G-YA ARC2 (Doc Approval)  
Power type : Powered by PC  
Power Cable : Shielded. 3M long, No ferrite bead data cable

**PABX** : **King Design**  
Model No. : KD8705-A  
Serial No. : GV101101186  
Power type : 220 VAC 50Hz  
Power cord : non-shielded, 1.8m long, no ferrite bead

## **Chapter 2 Conducted emission test**

### **Test condition and setup:**

All the equipment is placed and setup according to the CISPR 22. The EUT is assembled on a wooden table that is 80 cm high, is placed 40 cm from the back-wall that is a vertical conducting plane. One LISN is for EUT, the other LISN is for support equipment. They are all placed on the conductive ground. The EUT's LISN connect a line switch box for selecting L1 or L2, then connect to a preamplifier and spectrum.

The spectrum scans from 450KHz to 30MHz. Conducted emission levels are detected at max. peak mode. But if the max. peak mode failed or over average limit, it will be measured by average detection mode.

While testing, there is the worst-emission plot printed at peak detection mode, and there are more than 6 highest emissions relative to limit recorded. The plot is kept as the original data, not included in test report.

### **List of test Instrument :**

Instrument Name	Model No.	Brand	Serial No.	<b>Calibration Date</b>	
				Last time	Next time
Spectrum analyzer	8594EM	H P	3710A00198	06/29/00	06/29/01
LISN (EUT)	3825/2	EMCO	9411-2284	06/10/00	06/10/01
LISN (Support E.)	3825/2	EMCO	9210-2007	05/31/00	05/31/01
Preamplifier	EQ3-006	TRC	-----	05/15/00	05/15/01
Line switch box	EQ3-007	TRC	-----	05/15/00	05/15/01

The level of confidence of 95% , the uncertainty of measurement of conducted emission is  $\pm 2.4$  dB .

### **Test Result: Pass (Appendix A)**



*Conducted Test Placement: (Photographs)*



### **Chapter 3 Radiated emission test**

#### **Test condition and setup:**

**Pretest :** Prior to the final test (OATS test) ,the EUT is placed in a shielded enclosure, and scan from 30MHz to 1GHz. This is done to ensure the radiation exactly emits form the EUT.

**Final test:** Final radiation measurement is made on a **3 - meter**, open-field test site. The EUT is placed on a nonconductive table that is 0.8m height, the top surface is 1.0 x 1.5 meter. The placement is according to CISPR 22.

The spectrum is examined from 30 MHz to 1000 MHz measured by HP spectrum.

The M.E. whole range Antenna is used to measure frequency from 30 MHz to 1GHz.The final test is used the spectrum analyzer.

Measure more than six top marked frequencies generated form pretest by computer step by step at each frequency. The EUT is rotated 360 degrees, and antenna is raised and lowered from 1 to 4 meters to find the maximum emission levels. The antenna is used with both horizontal and vertical polarization.

Appropriated preamplifier that is made by TRC is used for improving sensitivity and precaution is taken to avoid overloading. The spectrum analyzer' s 6dB bandwidth is set to 120 KHz, and the EUT is measured at quasi-peak mode.

If the emission is close to the frequency band of ambient, the tester will recheck the data and the corrected data will be written in the test data sheet. If the emission is just within the ambient, the data from shield room will be taken as the final data.

#### **List of test Instrument :**

<u>Instrument Name</u>	<u>Model No.</u>	<u>Brand</u>	<u>Serial No.</u>	<u>Calibration Date</u>	
				<u>Last time</u>	<u>Next time</u>
Spectrum analyzer	8594EM	H P	3710A00279	06/22/00	06/22/01
Spectrum analyzer	8568B	H P	3710A00198	06/10/00	06/10/01
Antenna (30M-1.5G Hz)	VULB 9160	M.E.	3063	06/26/00	06/23/01
Antenna (30M-2G Hz)	3141	EMCO	9711-1076	05/15/00	05/15/01
RF Pre-selector	EQ3-003	TRC	-----	05/15/00	05/15/01
Open test side (Antenna, Amplify, cable calibrated together)				05/15/00	05/15/01

The level of confidence of 95% , the uncertainty of measurement of radiated emission is  $\pm 4.96$  dB .

#### **Test Result : Pass (Appendix B)**



*Radiated Test Placement: (Photographs)*



## Appendix A

### Conducted Emission Test Result:

Testing room:            Temperature : 20 ° C            Humidity : 67 % RH

#### Line 1

Frequency (KHz)	READING AMPLITUDE			LIMIT		Margin (dB)
	Peak (dBmV/m)	Quasi-Pea k (dBmV/m)	Average (dBmV/m)	Quasi-Pea k (dBmV/m)	Average (dBmV/m)	
608.00	27.35	***.***	***.***	48.00	48.00	-20.65
705.00	28.88	***.***	***.***	48.00	48.00	-19.12
813.00	28.65	***.***	***.***	48.00	48.00	-19.35
1009.00	27.72	***.***	***.***	48.00	48.00	-20.28
1113.00	29.03	***.***	***.***	48.00	48.00	-18.97
1516.00	29.53	***.***	***.***	48.00	48.00	-18.47
15490.00	28.50	***.***	***.***	48.00	48.00	-19.50
16590.00	27.57	***.***	***.***	48.00	48.00	-20.43
20260.00	34.76	***.***	***.***	48.00	48.00	-13.24
24300.00	48.52	47.14	44.64	48.00	48.00	-0.86

#### Line 2

Frequency (KHz)	READING AMPLITUDE			LIMIT		Margin (dB)
	Peak (dBmV/m)	Quasi-Pea k (dBmV/m)	Average (dBmV/m)	Quasi-Pea k (dBmV/m)	Average (dBmV/m)	
705.00	27.90	***.***	***.***	48.00	48.00	-20.10
813.00	29.37	***.***	***.***	48.00	48.00	-18.63
1009.00	29.53	***.***	***.***	48.00	48.00	-18.47
1120.00	29.74	***.***	***.***	48.00	48.00	-18.26
1215.00	28.44	***.***	***.***	48.00	48.00	-19.56
1516.00	28.82	***.***	***.***	48.00	48.00	-19.18
1623.00	29.02	***.***	***.***	48.00	48.00	-18.98
16480.00	28.89	***.***	***.***	48.00	48.00	-19.11
20260.00	34.45	***.***	***.***	48.00	48.00	-13.55
24300.00	47.91	***.***	***.***	48.00	48.00	-0.09

\* The reading amplitudes are all under limit.

**Appendix B**

**Radiated Emission Test Result: (Horizontal)**

Test Conditions:

Testing room : Temperature : 26.38 ° C      Humidity : 66 % RH  
 Testing site : Temperature : 28.45 ° C      Humidity : 72 % RH

Frequency	Reading Amplitude	Ant. Height	Table	Correction Factors	Corrected Amplitude	Class B Limit	Margin
MHz	dBμV	m	degree	dB/m	dBμV/m	dBμV/m	dB

176.641	51.39	2.51	80	-22.98	28.41	43.50	-15.09
229.633	53.66	0.99	88	-23.69	29.97	46.00	-16.03
247.297	58.37	0.99	171	-22.80	35.57	46.00	-10.43
***							

Note:

1. Margin = Amplitude - limit, *if margin is minus means under limit.*
2. Corrected Amplitude = Reading Amplitude + Correction Factors
3. Correction factor = Antenna factor + ( Cable Loss - Amplitude gain )  
 (For example : 30MHz correction factor = 15.5 + (-15.26) = 0.24 dB/m)

**Radiated Emission Test Result: (Vertical)**

<b>Frequency</b>	<b>Reading Amplitude</b>	<b>Ant. Height</b>	<b>Table</b>	<b>Correction Factors</b>	<b>Corrected Amplitude</b>	<b>Class B Limit</b>	<b>Margin</b>
MHz	dBμV	m	degree	dB/m	dBμV/m	dBμV/m	dB

141.306	59.70	2.51	93	-21.02	38.68	43.50	-4.82
158.979	57.78	0.99	71	-21.12	36.66	43.50	-6.84
229.637	54.82	0.99	61	-23.69	31.13	46.00	-14.87
264.966	52.59	0.99	86	-22.08	30.51	46.00	-15.49
***							