

# RF Emissions Test Report To Determine Compliance With: EN55022 and FCC, Part 15 Rules and Regulations

**Model number:** SD300

April 22, 2003

**Manufacturer:** CoaXmedia  
1220 Oak Industrial Lane  
Suite B  
Cumming, GA 30041

<b><u>Contents</u></b>	<b><u>Section</u></b>
General Information.....	1
Test Summary.....	2
Standard Reference .....	3
Test Method .....	4
Radiated Emissions Measurements .....	5
Conducted Emissions Measurements.....	6
Configuration and Photographs .....	7

## Section 1

### General Information

**Manufacturer:** CoaXmedia  
1220 Oak Industrial Lane  
Suite B  
Cumming, GA 30041

**Manufacturer representative:** **Mr. Stephane Chapeau**

**Equipment covered by this report:** Model number: SD300

**Options covered by this report:** None

**Equipment serial no.** Prototype

**Test specifications:** To determine compliance with:  
CISPR 22/EN55022 and  
FCC, Part 15, Subpart B  
Rules and Regulations.  
Class B

**Test report number:** 03-140A

**Test commenced:** April 21, 2003

**Test completed:** April 21, 2003

**Test engineer:** **Ed Barnes**

**Test Facility:** The test facility used to perform these tests is on file with  
the FCC under registration number 637500 and located at:

**EMC Testing Laboratories, Inc.**  
2210 Justin Trail  
Alpharetta, GA 30004

## Section 2

### Test report summary sheet 1 of 3

**Summary:**

Tests	Results
FCC, Part 15, Class B, Radiated emissions:	<b>Pass</b>
FCC, Part 15, Class B, Conducted emissions:	<b>Pass</b>
EN55022, Class B, Radiated emissions	<b>Pass</b>
EN55022, Class B, Conducted emissions	<b>Pass</b>

- 1- The product(s) covered by this report was found to comply with the Class B limits of the FCC, Part 15, Subpart B Rules and Regulations and CISPR 22/EN55022.
- 2- The minimum margin of compliance was **-11.0 dB $\mu$ v/m** at 49.6 Mhz followed by **-21.1 dB $\mu$ v/m** at .45 Mhz.
- 3- The test results apply only to the products identified on the test report.

**Product description:**

The equipment under test (EUT) consisted of a model SD300, broadband gateway for use in enabling high-speed Internet connectivity over a building's coaxial distribution system. Provided with an external power supply, manufactured by Ventronics, part no. R48W051000-14/1, rated 120V or manufactured by GlobTek, part no. GT-3T48-5-10000R-3 or WR23A10000LCP-N, rated 220V.

During the 120V conducted emissions testing the EUT was powered from an external I.T.E. power supply, manufactured by Ventronics, part no. R48W051000-14/1

During the 220V conducted emissions testing the EUT was powered from an external I.T.E. power supply, manufactured by GlobTek, part no. GT-3T48-5-10000R-3 and WR23A10000LCP-N.

The enclosure is constructed of thermoplastic material with overall dimensions measuring 11.5cm wide by 13.5cm deep by 3.0cm maximum height and encloses the following components judged as critical:

1. A printed wiring board manufactured by coaXmedia, part no. 311010-001, Rev. A.

## Test report summary sheet 2 of 3

### **Test configuration:**

The equipment under test was set-up and configured as specified by the manufacturer as follows:

Note: The broadband gateway was positioned away from the EUT during testing.

1- The EUT was connected to the following support peripherals:

- A) A laptop computer, manufactured by Dell, part no. PPX, serial no. 62HMN, FCC marked.
- B) A mouse, FCC ID: C3KKMP1.
- C) A broadband gateway.
- D) Printer, manufactured by HP, model no. 712C, FCC ID: B94C4557X.

2- The EUT utilized the following cables and were connected as indicated below:

- A) An unshielded Ethernet cable, part no. 506009-001 was connected from the EUT's Ethernet port to the laptop computer's Ethernet port.
- B) An unshielded, coax cable was connected to the broadband gateway.
- C) An unshielded power cord, integral to the external power supply, was connected to the EUT's INPUT power port.
- D) A standard printer cable connected the printer to the laptop computer.

### **Test operation:**

For all measurements, the equipment under test was caused to function in a continuous mode of operation for maximum electrical activity as specified by the manufacturer. Specifically, the EUT was made to continuously send and receive a ping signal between the laptop and the broadband gateway.

## Test report summary sheet 3 of 3

**Marking:** (For the European market and Class A products only)

Class A products are marked as follows:

**Warning:** This is a Class A product. In a domestic environment, this product may cause radio interference in which case the user may be required to take adequate measures.

**Modifications:**

The following modifications were required to comply with the radiated emission limits:

1. When provided with the power supply manufactured by GlobTek, part no. WR23A10000LCP-N, a capacitor, C309, rated 680  $\mu$ F is required.

**Engineering Statement:**

All measurement data of this test report was taken in accordance with the European Normative EN55022 (1994), FCC, Part 15, Subpart B Rules and Regulations and ANSI C63.4-1992 by EMC Testing Laboratories, Inc. located in Alpharetta, Georgia. Although this data is taken under stringent laboratory conditions and, to the best of our knowledge, represents accurate data, it must be recognized that emissions from or immunity to this type equipment may be greatly affected by the final installation of the equipment. Therefore, EMC Testing Laboratories, Inc., while supporting the accuracy of the data in this report, takes no responsibility for use of equipment based on these tests. The manufacturer of this equipment must take full responsibility for any field problems which may arise, and agrees that EMC Testing Laboratories, Inc., in performing its functions in accordance with its objectives and purposes, does not assume or undertake to discharge any responsibility of the manufacturer to any other party or parties.

**Conclusion:**

With the above indicated modifications, the product(s) covered by this report has been tested and found to comply with the limits for a Class B device in accordance with 1) C.I.S.P.R 22/EN55022 and 2) the FCC, Part 15, Subpart B Rules and Regulations.

Tested by:

Reviewed by:

**Ed Barnes**  
**Test Engineer**  
**EMC Testing Laboratories, Inc.**

**Gene J. Bailey**  
**Engineering Manager**  
**EMC Testing Laboratories, Inc.**  
April 22, 2003

This page intentionally left blank.

(Reserved for future use)

## Section 3

### Standard Reference

The following primary standards were used for this test:

- 1) **ANSI C63.4-1992:** Method of Measurements of Radio-Noise Emissions from Low-Voltage Electrical and Electronic Equipment in the 9 Khz to 40 Ghz.
- 2) **US Code of Federal Regulations (CFR) (1998):** Title 47, Part 15, Radio Frequency Devices, Subpart B, Unintentional Radiators.
- 3) **C.I.S.P.R 22 (1997):** Limit and Methods of Measurement of Radio Interference Characteristics of Information Technology Equipment.
- 4) **EN55022 (1994):** Limits and Methods of Measurement of Radio Interference Characteristics of Information Technology Equipment.



## Section 4

### Test Method

#### **INTRODUCTION:**

The product(s) covered by this report were subjected to electromagnetic interference emissions measurements to determine compliance with the EMI portion of the EC directive 92/336/EEC as specified in CISPR 22/EN55022. In addition, the product was evaluated for compliance with the FCC, Part 15 requirements.

Radiated and conducted emissions were measured in accordance with the Limits and Methods of Measurement of Radio Interference Characteristics of Information Technology Equipment, C.I.S.P.R 22 /EN55022 and Methods of Measurement of Radio- Noise Emissions from Low-Voltage Electrical and Electronic Equipment in the Range of 9 Khz to 40 Ghz, ANSI C63.4.

#### **MEASUREMENT CALCULATIONS:**

##### **Radiated Emissions:**

For radiated emissions measurements, the signal attenuation due to impedance losses in the antenna and signal cable were significant and was added to the spectrum analyzer reading to give corrected signal strength reading. If a preamplifier was used, the signal gain was subtracted from the signal strength reading. Radiated emissions data was specified as decibels above 1 microvolt per meter (dB $\mu$ V/m) of radiated field strength.

$$\text{Radiated emissions (dB}\mu\text{V)} = \text{Analyzer reading (dB}\mu\text{V)} \text{ plus} \\ \text{antenna factor (dB) plus cable factor (dB) minus Amplifier gain (dB)}$$

##### **Conducted Emissions:**

For conducted emissions, the signal attenuation due to impedance losses in the LISN and signal cables were negligible and assumed to be 0dB. The conducted emissions were directly equal to the spectrum analyzer reading. Conducted emissions data was specified as decibels above 1 microvolt (dB $\mu$ V) of conducted line voltage.

$$\text{Conducted emissions (dB}\mu\text{V)} = \text{Analyzer reading (dB}\mu\text{V)}$$

## **RADIATED EMISSIONS MEASUREMENT:**

Radiated emissions measurements were performed at an open field test site. The receiving antenna was positioned 10 meters from the equipment under test along the center axis of the test site. Measurements were made with broadband antennas and if necessary, detected emissions were verified with dipole antennas. The dipole antenna was manually tuned to the signal frequency by adjusting the length of the antenna elements. The radiated emissions were measured for both the horizontal and vertical signal planes by rotating the antennas. Additionally, the EUT was rotated by the turntable and the antenna height was raised and lowered 1 to 4 meters to locate the maximum emission strength at each frequency.

The radiated emissions were measured over the frequency span of 30 Mhz to 5.0 Ghz. The following antennas were used to measure the radiated emissions within the specified frequency spans.

<u>Antenna</u>	<u>Frequency Span</u>
Biconical	20 - 200 Mhz
Log Periodic	200 - 1000 Mhz
Dipoles	20 - 1000 Mhz
Horn	1-18 Ghz

## **CONDUCTED EMISSIONS MEASUREMENT:**

Conducted emissions measurements were performed on a ground plane that was electrically bonded to earth ground. The equipment under test was positioned 0.8 meter above the ground plane and 0.8 meter minimum from the LISN that was positioned on the ground plane. The LISN housings were electrically bonded to the ground plane. The conducted emissions for both the ungrounded supply conductor (L1) and the grounded conductor (L2) of the power supply cord were measured. The conducted emissions were measured over the frequency span of 0.15 to 30 Mhz. The measurements were conducted in the quasi-peak and average detector modes.

**INSTRUMENTATION:**

Radiated and conducted signal strength measurements were taken with a spectrum analyzer. Radiated emissions were measured with broadband and tuned dipole antennas. Conducted emissions were measured with a 50ohm/50μH line impedance stabilization network (LISN). The test equipment consists of the following:

<u>Test Equipment</u>	<u>Model No.</u>	<u>Serial No.</u>	<u>Cal. Due</u>
Spectrum Analyzer	HP 8591A	3144A02506	01-06-04
Spectrum Analyzer	8592L	3649A00744	01-10-04
LISN	94641-1	0145/0146	06-05-03
LISN	3825/2	9305-2088	08-21-03
LISN	LI-210	25145	07-10-03
Biconical Antenna	3110B	1708	10-01-03
Biconical Antenna	BIA-25	2451	09-18-03
Log Periodic	LPA25	1112	10-01-03
Dipole Antenna	DM-105A-T1	31402-110	06-05-03
Dipole Antenna	DM-105A-T2	31402-105	06-05-03
Dipole Antenna	DM-105A-T3	31402-109	06-05-03
Horn Antenna	3115	9405-4264	10-01-03
R.F. Amplifier	QB-820	11602	01-11-04
Preamplifier	8449B	3008A00914	01-07-04

**DETECTOR FUNCTION:**

All measurements were taken using a peak hold signal detector function. In this mode, the spectrum analyzer makes continuous scans across the frequency band and stores the highest emission value detected at each frequency for all scans. The peak hold integration will detect transient or low duty cycle emissions peak which might be missed on single scan measurement. The emission value at each frequency was a true value.

**SPECTRUM ANALYZER SETTING:**

For all measurements, the spectrum analyzer was set for a 10 dB input attenuation, 10 dB/Division vertical scale and 90 or 100 dBμV reference level. The resolution bandwidth was set at 9 KHz for the 0.15 - 30 Mhz span and at 120 KHz for 30 Mhz to 5.0 Ghz span. The video bandwidth and sweep rate were automatically coupled by the analyzer.

## Section 5

# RADIATED EMISSIONS MEASUREMENTS

## RADIATED EMISSIONS MEASUREMENTS

**Model number:** SD300

**Test Date:** 04/21/03

<b>Frequency Mhz</b>	<b>Measurement Reading dB<math>\mu</math>V/m</b>	<b>Corrected Reading dB<math>\mu</math>V/m</b>	<b>EN55022 Limit dB<math>\mu</math>V/m</b>	<b>FCC Limit dB<math>\mu</math>V/m</b>	<b>Minimum Margin dB<math>\mu</math>V/m</b>
<b>Vertical</b>					
30.6	22.1	14.2	30.0	29.5	- 15.3
125	28.0	19.4	30.0	33.0	- 10.6
<b>Horizontal</b>					
49.6	39.2	28.0	30.0	29.5	- 1.5
200	30.5	22.1	30.0	33.0	- 7.9
400	28.4	24.7	37.0	35.5	- 10.8
700	25.3	28.5	37.0	35.5	- 7.0

## Section 6

# CONDUCTED EMISSIONS MEASUREMENTS

## CONDUCTED EMISSIONS MEASUREMENTS

**Model number:** SD300

**Test voltage:** 120V 60Hz

**Test Date:** 04/21/03

Power supply, Ventronics, Part no. R48W051000-14/1

Frequency Mhz	Reading dBuV, L1	Frequency Mhz	Reading dBuV, L2	FCC Limit, dBuV	Margin dBuV
.498	29.6	.450	44.9	66.0	-21.1
18.6	21.2	17.7	35.8	60.0	-24.2
-	-	18.3	35.3	60.0	-24.7
-	-	20.2	31.1	60.0	-28.9

**Model number:** SD300**Test voltage:** 220V 60Hz**Test Date:** 04/21/03

Power supply, Globtek, part no. GT-3T48-5-1000R-3

Frequency Mhz	Reading dBuV, L1	Frequency Mhz	Reading dBuV, L2	CISPR Limit, dBuV	Margin dBuV
.474	38.7	.450	26.3	66.0	-27.3
16.3	36.0	16.3	34.0	60.0	-24.0
21.6	37.6	17.7	33.1	60.0	-22.4

Power supply, Globtek Inc. – Part No. WR23A1000 LCP-N

Frequency Mhz	Reading dBuV, L1	Frequency Mhz	Reading dBuV, L2	CISPR Limit, dBuV	Margin dBuV
.15	38.8	.15	34.8	66.0	-27.2
.79	24.0	.79	24.4	60.0	-35.6
2.3	20.7	2.3	21.8	60.0	-38.2
14.6	19.1	14.6	21.6	60.0	-38.4



## Section 7

### Configuration and Photographs

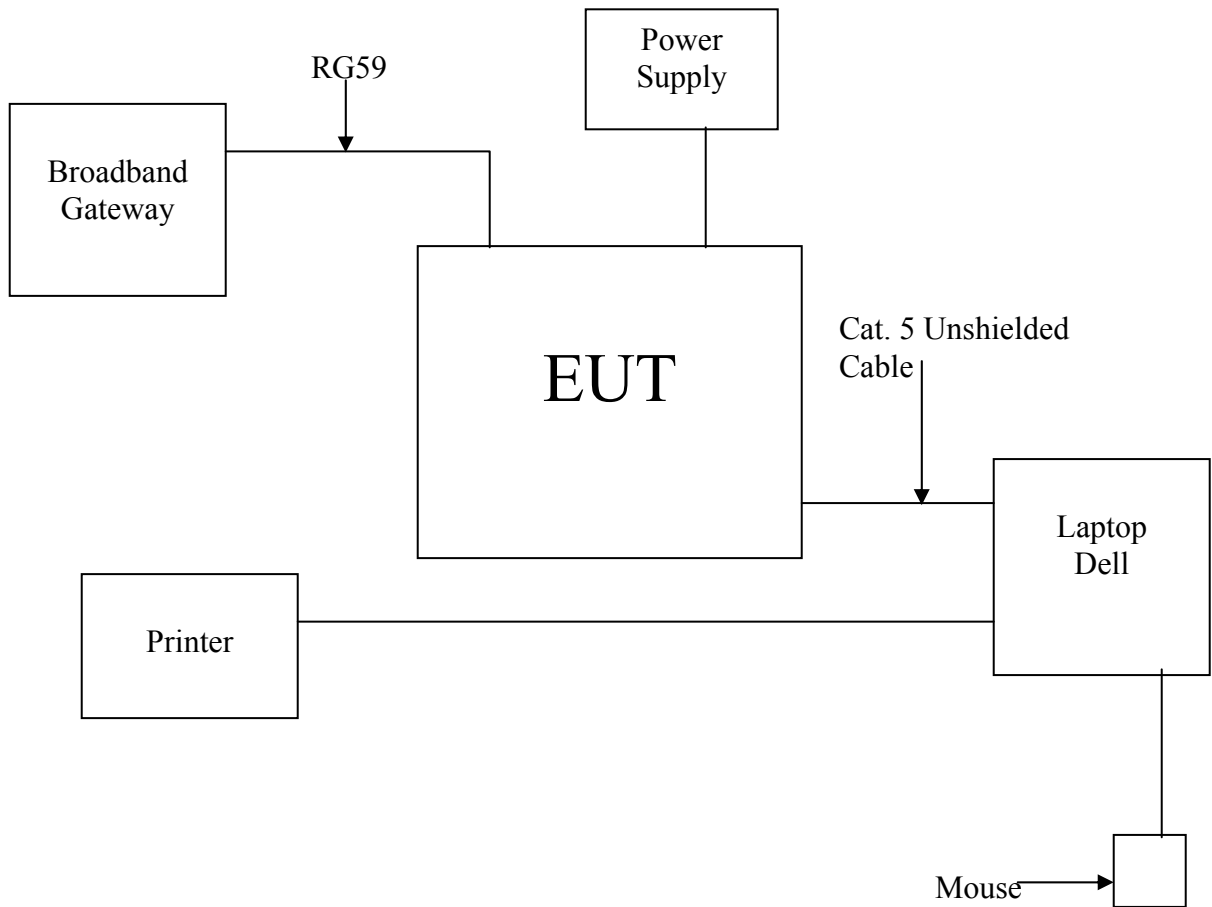

Photographs cont...

Photographs cont...

Photographs cont...

**LAST PAGE ...**