



Underwriters Laboratories Inc.

www.ul.com/emc
www.ulk.co.kr

Project No.: 12CA08535

File No.: MC16340

Report No.: 12CA08535-4-FCC

Date: August 17, 2013

Model No.: FXRD-1417WA (Basic), FXRD-1417WB

FCC ID.: PFRFXRD1417W

RF Test Report

in accordance with
FCC Part 15 Subpart C §15.247

for

Detector

Vieworks Co., Ltd.
#601 ~ 610, Suntechcity 2, 307-2, Sangdaewon-dong Jungwon-Gu
Seongnam-city Gyeonggi-do, 462-806, South Korea

Copyright © 2005 Underwriters Laboratories Inc.

Underwriters Laboratories Inc. authorizes the above-named company to reproduce this Report provided it is reproduced in its entirety.

Only those products bearing the UL Mark should be considered as being covered by UL.

Summary of Test Results:

The following tests were performed on a sample submitted for evaluation of compliance with FCC Part 15 C Section 15.247				
No	Reference Clause No.	FCC Part15 Subpart C Conformance Requirements	Result Verdict	Remark
	FCC Rule			
1	15.247(a) (2)	6dB Bandwidth Measurement	N/A	*Note ³
2	-	99% Bandwidth Measurement	N/A	*Note ³
3	15.247 (e)	Power Spectral Density Measurement	N/A	*Note ³
4	-	Average Power Measurement	N/A	*Note ³
5	15.247(b)	Peak Power Measurement	N/A	*Note ³
6	15.247(d)	Conducted Spurious Emission Measurement	N/A	*Note ³
7	15.247(d)	Band Edges Measurement	Complied	-
8	15.247(d)	Radiated Emission Measurement	Complied	-
9	15.247	AC Conducted Emission Measurement	N/A	*Note ²

*Note 1: N/T=Not Tested, N/A=Not Applicable

*Note 2: The power input of EUT is DC type.

*Note 3: Test was performed by modular transmitter (FCC ID : PPD-AR5BHB116)

Compliance with FCC rules is being demonstrated by performing radiated spurious emissions on the host system and providing the test reports for the rf module used in this system to cover the antenna port measurement requirements.

The modular reports allow for a maximum gain PIFA antenna to be 3.0dBi/3.6dBi in the 2.4GHz band and 4.8dBi in the 5GHz bands. This host device uses a PCB antenna with a maximum gain of 4.7dBi in the 2.4GHz band and 2.2dBi in the 5GHz bands, therefore the limits used for the output power and power spectral density in the modular reports for 5GHz operations (DTS and NII) show compliance for the host using these antennas as they are of equal or lower gain. For 2.4GHz operations the composite gain for 2x2 beamforming modes is 7.7dBi. the output power limit for a 7.7dBi antenna is 28.3dBm. the maximum measured output power was 27.19dBm which complies with this limit of 28.3dBm. All bandwidth, power and power density measurements were made in accordance with the latest FCC KDB guidance documents for DTS and NII transmitters.

Radiated spurious emissions were tested for the host system so the different antenna type is covered by the system level tests.

Conclusion:

The tests listed in the Summary of Testing section of this report have been performed and the results recorded by UL Korea Ltd. in accordance with the procedures stated in each test requirement and specification. The test list was determined by the Applicant as being applicable to the Equipment Under Test. As a result, the subject product has been verified to comply or not comply as noted in the Summary of Testing with each test specification. The test results relate only to the items tested.



Witness tested by
 Hongsuk Oh, WiSE Associate Project Engineer
 UL Verification Services- 3014ASEO
 UL Korea Ltd.
 Aug. 17, 2013



Reviewed by
 Jeawoon, Choi, WiSE Operations Manager
 UL Verification Services- 3014ASEO
 UL Korea Ltd.
 Aug. 17, 2013

Test Report Details

Test Report No: 12CA08535-4-FCC
Witness Tests Performed By: UL Korea Ltd.
33rd FL. GFC Center, 737 Yeoksam-dong, Gangnam-gu, Seoul, 135-984, Korea
Test Site: KES Co., Ltd.
477-6, Hageo-ri, Yeosu-eup, Yeosu-gun, Gyeonggi-do, 469-803, Korea
Applicant: Vieworks Co., Ltd.
#601 ~ 610, Suntechcity 2, 307-2, Sangdaewon-dong Jungwon-Gu Seongnam-city Gyeonggi-do, 462-806, South Korea
Applicant Contact: Jeong-mi Kim
Title: Manager
Phone: +82-70-7011-6176
Fax: +82-31-737-4953
FCC ID: PFRFXRD1417W
E-mail: salangshy@vieworks.com
Product Type: X-ray Detector
Model Number: FXRD-1417WA
Multiple Model Name: FXRD-1417WB
The manufacturer has declared to all the multiple model names into the basic model without any further evaluation by UL.

Trademark



Sample Serial Number: N/A
Test standards: FCC Part 15 C Section 15.247
Sample Serial Number: N / A
Sample Receive Date: 2013.07.09
Testing Date: 2013.07.30 ~ 2013.08.09
Test Report Date: 2013.08.17
Overall Results: Pass

UL Korea Ltd. reports apply only to the specific test samples and test results submitted for UL's review. All samples tested were in good operating condition throughout the entire test program. It is the manufacturer's responsibility to assure that additional production units of this model are manufactured with identical electrical and mechanical components. UL Korea Ltd. shall have no liability for any deductions, inferences or generalizations drawn by the client or others from UL Korea Ltd. issued reports. This report shall not be used to claim, constitute or imply product certification, approval, or any agency of the National Authorities. This report may contain test results that are not covered by the NVLAP or KOLAS accreditation.

REPORT DIRECTORY

1. GENERAL PRODUCT INFORMATION	5
1.1 EQUIPMENT DESCRIPTION	5
1.2 DETAILS OF TEST EQUIPMENT (EUT)	5
1.3 EQUIPMENT CONFIGURATION	5
1.4 TECHNICAL DATA.....	5
1.5 ANTENNA INFORMATION	5
1.6 EQUIPMENT TYPE :	6
1.7 TECHNICAL DESCRIPTIONS AND DOCUMENTS	6
1.8 EQUIPMENT MARKING PLATE.....	6
1.9 DESCRIPTION OF ADDITIONAL MODEL NAME.....	7
2. TEST SPECIFICATION.....	7
3. TEST CONDITIONS.....	7
3.1 EQUIPMENT USED DURING TEST	7
3.2 INPUT/OUTPUT PORTS	7
3.3 POWER INTERFACE	7
3.4 OPERATING FREQUENCIES	8
3.5 OPERATION MODES	8
3.6 TEST CONFIGURATIONS	9
3.7 LIST OF TEST EQUIPMENT.....	9
4. OVERVIEW OF TECHNICAL REQUIREMENTS	10
4.1 ANTENNA REQUIREMENT	10
5. TEST RESULTS.....	11
5.1 TRANSMITTER RADIATED SPURIOUS EMISSIONS	11

1. General Product Information

1.1 Equipment Description

Wireless communication is established between the ViVIX-S Wireless detector and System Control Unit.

1.2 Details of Test Equipment (EUT)

- Equipment Type : X-ray Detector
- Model No. : FXRD-1417WA, FXRD-1417WB
- Operating characteristic : Short range wireless device operating in the 2400 – 2483.5 ISM frequency band
- Manufacturer : Vieworks Co., Ltd.
 #601 ~ 610, Suntechcity 2, 307-2, Sangdaewon-dong Jungwon GuSeongnam-city
 Gyeonggi-do, 462-806, South korea

1.3 Equipment Configuration

The EUT is consisted of the following component provided by the manufacturer.

Use*	Product Type	Manufacturer	Model	Comments
EUT	X-ray Detector	Vieworks Co., Ltd.	FXRD-1417WA	S/N : D3CABH001
EUT	Battery	Vieworks Co., Ltd.	FXRB-01A	S/N : B1-AAAT002
*Note: Use = EUT - Equipment Under Test, AE - Auxiliary/Associated Equipment. SIM - Simulator (Not Subjected to Test)				

1.4 Technical Data

Item	X-ray Detector
Frequency Ranges	2412 ~ 2462 MHz, 5745~5825 MHz,
Kind of modulation (s)	DSSS (CCK), OFDM(BPSK, QPSK, 16QAM, 64QAM)
Channel	2412 ~ 2462 MHz: 11 channel(11b/g/n_HT20), 2422 ~ 2452 MHz : 7 channel(11n_HT40) 5745~5825 MHz: 5 channel(11a/n_HT20– Non DFS) 5755 ~ 5795 MHz: 2 channel(11n_HT40 – Non DFS)
Antenna information	Integral type (PCB antenna)
Working temperature	-20 ~ 70 °C
Supply Voltage	DC +24 V
*Note: All the technical data described above were provided by the manufacturer.	

1.5 Antenna Information

Item	X-ray Detector
Antenna Model Name	AEi-2450/5500DP-C1.13[Vieworks]
Antenna Type	PCB antenna
Manufacturer	Viework Co., Ltd.
GAIN(dBi) - 2.4GHz	4.66 dBi

GAIN(dBi) - 5GHz	2.19 dBi
Polarization	Isotropic
*Note: All the technical data described above were provided by the manufacturer.	

1.6 Equipment Type :

- Radio and ancillary equipment for fixed or semi-fixed use
- Radio and ancillary equipment for vehicular mounted use
- Radio and ancillary equipment for portable or handheld use

- Stand alone Host connected

- Self contained single unit Module with associated connection or interface

1.7 Technical descriptions and documents

No.	Document Title and Description
1	User Manual
*Note: The following document was provided by the manufacturer.	

1.8 Equipment Marking Plate

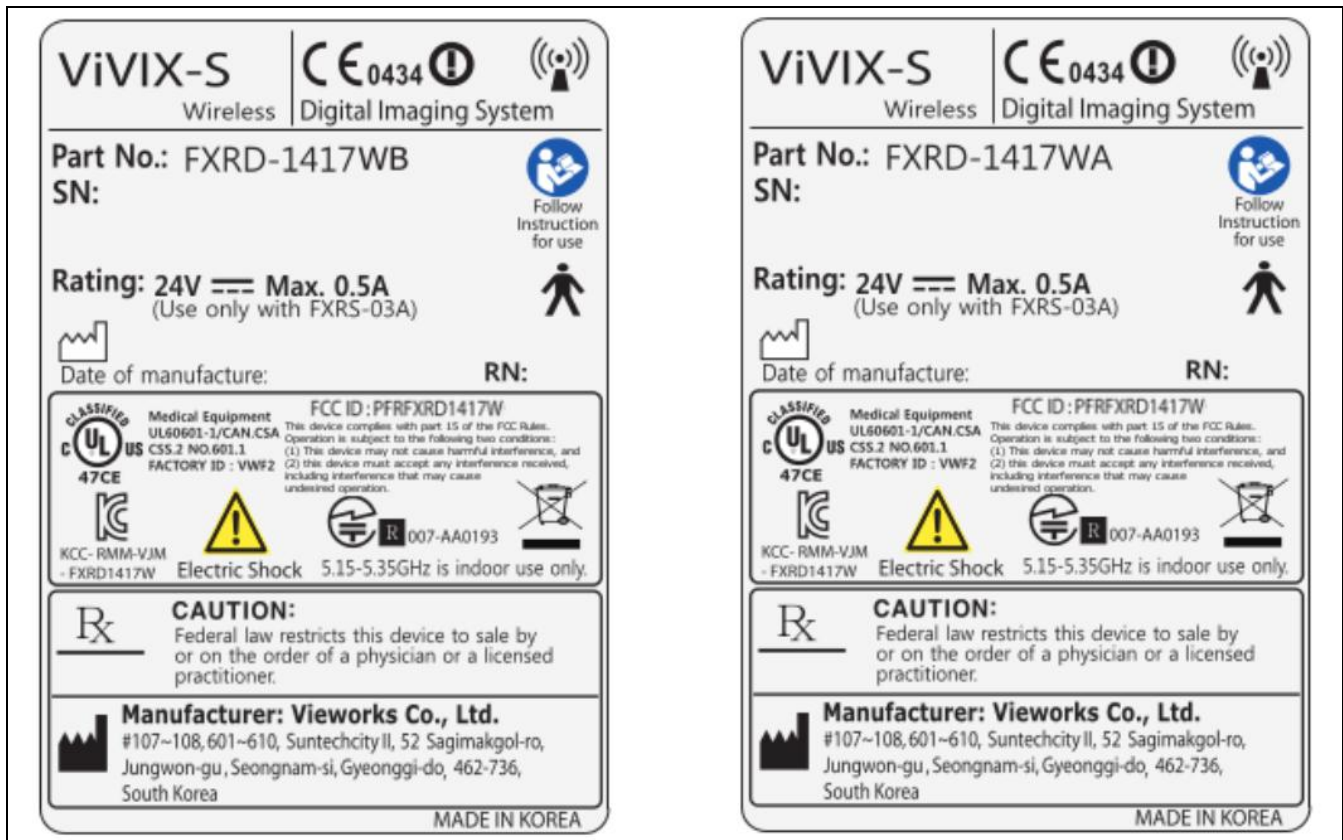

1.9 Description of additional model name

Model name	Model name Designation	Description of design
FXRD-1417WB	Identical to FXRD-1417WA	Depending on scintillator of detector, the model name is different. Scintillator is CsI(Tl), model name is FXRD-1417WA. And also when the scintillator is Gadox, model name is FXRD-1417WB.

2. Test Specification

The following test specifications and standards have been applied and used for testing.

1) FCC Part 15 C Section 15.247

Operation within the bands 902–928 MHz, 2400–2483.5 MHz, and 5725–5850 MHz

2) ANSI C63.4:2009

American National Standard for Methods of Measurement of Radio- Noise Emissions from Low-Voltage Electrical and Electronic Equipment in the Range of 9 kHz to 40 GHz

3. Test Conditions

3.1 Equipment Used During Test

Use*	Product Type	Manufacturer	Model	Comments
EUT	X-Ray Detector	Vieworks Co., Ltd.	FXRD-1417WA	S/N : D3CABH001
EUT	Battery	Vieworks Co., Ltd.	FXRB-01A	S/N : B1-AAAT002
AE	System Control Unit	Vieworks Co., Ltd.	FXRS-03A	-
AE	Note PC	Lenovo	X2000	-

*Note: Use = EUT - Equipment Under Test, AE - Auxiliary/Associated Equipment. SIM - Simulator (Not Subjected to Test)

3.2 Input/Output Ports

Port #	Name	Type*	Cable Max. >3m	Shielded	Comments
1	Signal port	I/O	15 m	Shielded	SCU to X-Ray detector Cable

*Note 1: All the interface cables and Power Cable have been provided by the manufacturer

*Note 2: *AC = AC Power Port DC = DC Power Port N/E = Non-Electrical
 I/O = Signal Input or Output Port (Not Involved in Process Control) TP = Telecommunication Ports

3.3 Power Interface

Mode #	Voltage (V)	Current (A)	Power (W)	Frequency (DC/AC-Hz)	Comments
Rated	DC +24 V	Max. 0.5 A	-	DC	Rated of Battery
1	DC +24 V	-	-	DC	

3.4 Operating Frequencies

Mode #	Frequency tested
1	<p>Operating frequency range: 2 412 MHz ~ 2 462 MHz (11b/g & n_HT20)</p> <p>3 channels in the Transmitter modes of 11b/g/n-HT20 are tested.</p> <p>- Low : 2412 MHz / CH = 1</p> <p>- Mid : 2437 MHz / CH = 6</p> <p>- Top : 2462 MHz / CH= 11</p>
2	<p>Operating frequency range : 2 422 MHz ~ 2 452 MHz (11n_HT40)</p> <p>3 channels in the Transmitter modes of 11n-HT40 are tested.</p> <p>- Low : 2422 MHz / CH = 3</p> <p>- Mid : 2437 MHz / CH = 6</p> <p>- Top : 2452 MHz / CH= 9</p>
3	<p>Operating frequency range : 5 745 MHz ~ 5 825 MHz (11a & n_HT20)</p> <p>3 channels in the Transmitter modes of 11a/n-HT20 are tested.</p> <p>- Low : 5745 MHz / CH = 149</p> <p>- Mid : 5785 MHz / CH = 157</p> <p>- Top : 5825 MHz / CH= 165</p>
4	<p>Operating frequency range : 5 755 MHz ~ 5 795 MHz (11an_HT40)</p> <p>2 channels in the Transmitter modes of 11n-HT40 are tested.</p> <p>- Low : 5755 MHz / CH = 151</p> <p>- Top : 5795 MHz / CH= 159</p>

3.5 Operation Modes

Mode #	Description
1	Carrier on mode: Signal from the RF module was generated continuously for the representative channels (Low, Mid, High) by the test program incorporated
2	Carrier off (Idle) mode: RF carrier was not activated by the RF module.
<p>*Note:</p> <ol style="list-style-type: none"> The worst-case condition is determined by the baseline measurement of rf output power of the modular transmitter test report. The worst-case channel was determined as the channel with highest output power. Output power from the device during the radiated spurious measurements are within expected tolerance of the module test results to justify using the original conducted antenna port measurements for the module(average power). <ul style="list-style-type: none"> - . 11b/g : 17.0 dBm, 11n-HT20 : 16.0 dBm, 11n-HT40: 13.0 dBm for each channel - . 11a/n-HT20/40 : 16.0 dBm for each channel. 	

3.6 Test Configurations

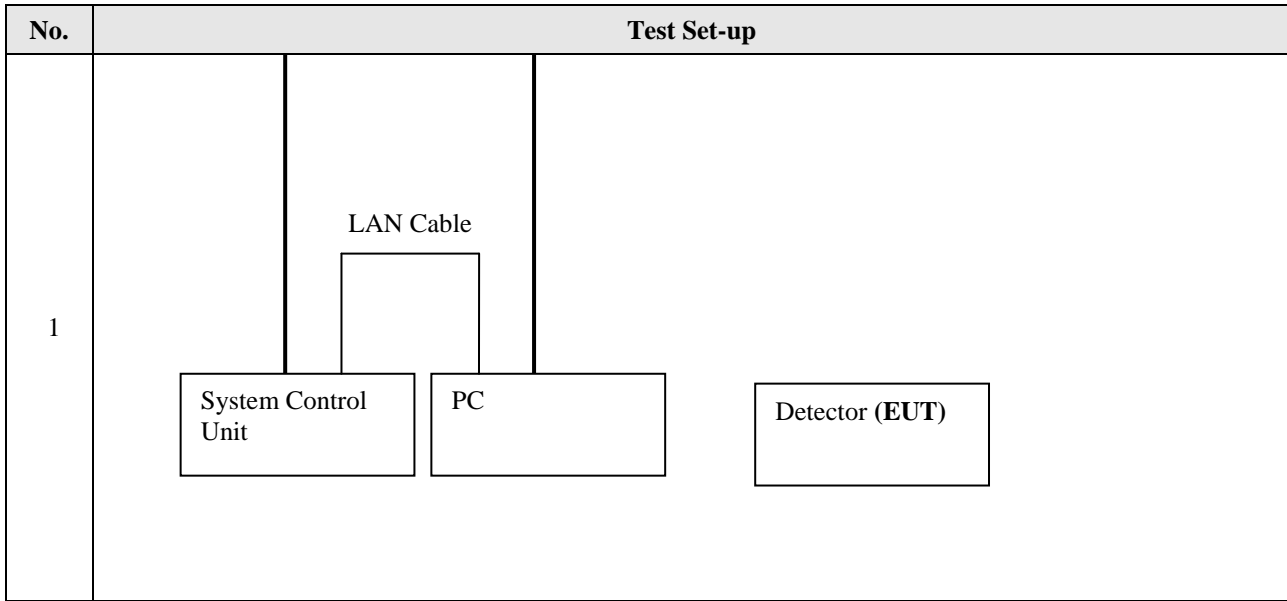

3.7 List of Test Equipment

No	Description	Manufacturer	Model	Identifier	Cal. Due
1	Spectrum Analyzer	R&S	FSV30	100736	2014.01.09
2	8360B Series Swept Signal Generator	HP	83630B	3844A00786	2014.06.06
3	Low Pass Filter	Mini-Circuits	NLP-1200+	V8979400903-1	2014.07.11
4	High Pass Filter	Wainwright Instrument	WHK6.0/18G-10SS	11	2014.07.07
5	High Pass Filter	Wainwright Instrument	WHJS3000-10TT	1	2014.01.10
6	Trilog-BroadBand Antenna	Schwarzbeck	VULB 9168	9168-462	2013.10.25
7	Horn Antenna	A.H.	SAS-571	414	2014.03.22
8	Preamplifier	R&S	SCU18	0117	2014.01.12
9	EMI Test Receiver	R&S	ESU40	100336	2014.06.27
10	Horn Antenna	ETS-Lindgren	3116	00062916	2015.03.20
11	Preamplifier	R&S	SCU40	10023	2013.11.15

4. Overview of Technical requirements

The following tests were performed on a sample submitted for evaluation of compliance with FCC Part 15 C Section 15.247				
No	Reference Clause No.	FCC Part15 Subpart C Conformance Requirements	Test method	Reported
1	15.205(a)	Restricted bands of operation	Note 1	[X]
2	15.209(a)	Radiated emission limits, general requirements	Note 1	[X]
3	15.247(d)	Transmitter radiated spurious emissions	Note 1	[X]
4	1.1307(b)(1)	Maximum Permissible Exposure (Exposure of Humans to RF Fields)	KDB 447498	Replaced by modular report
5	15.203	Antenna Requirement	-	[X]

***Note:** N/T=Not Tested, N/A=Not Applicable

Note 1: The measurement procedures described in the American National Standard for Methods of Measurement of Radio-Noise Emission from Low-Voltage Electrical and Electronic Equipment in the Range of 9 kHz to 40 MHz (ANSI C63.4-2003), the guidance provided in KDB 558074 and KDB 662911 were used in the measurement of the DUT.

Note 2: This device use already certified module so that the below specified test items are not tested in the end product evaluation. (TX Module FCC ID : PPD-AR5BHB116, Test Report no. FR080603A issued on Sep.16,2010 by Sporton International Inc.)

- . 6dB bandwidth
- . Tx Output Power
- . Band edge
- . Tx Spectral Power Density

4.1 Antenna Requirement

1.1.1. Standard Applicable

For intentional device, according to FCC 47 CFR Section §15.203, an intentional radiator shall be designed to ensure that no antenna other than that furnished by the responsible party shall be used with the device. And according to FCC 47 CFR Section § 15.247 (b), if transmitting antennas of directional gain greater than 6 dBi are used, the power shall be reduced by the amount in dB that the gain of the antenna exceeds 6 dBi.

1.1.2. Antenna Connected Construction

The antenna used of this product is dipole Antenna Assembly and peak max gain of each antennas as below. Antenna is permanently installed in the end product enclosure and no user exchange is allowed.

Band	2412 – 2462 MHz	5745 – 5825 MHz 5180 – 5320 MHz 5500 – 5700 MHz
Antenna Gain (dBi)	4.66 dB Max.	2.19 dB Max.

5. Test Results

5.1 Transmitter radiated spurious emissions

TEST: Transmitter radiated spurious emissions		
Method	Radiated emissions from the EUT were measured according to ANSI C63.4 procedure. 1. The EUT was placed on the top of a rotating table 0.8 meters above the ground at a 3 meter anechoic chamber test site. The table was rotated 360 degrees to determine the position of the highest radiation. The antenna is varied from 1 to 4 meters above the ground to find the maximum field strength. Measurement are made with both horizontal and vertical polarizations For fundamental investigation, the EUT was positioned for 3 orthogonal orientations. 2. For measurement below 1GHz, the resolution bandwidth is set to 100 kHz for peak detection or 120kHz for quasi-peak detection measurements. Peak detection is used unless otherwise noted as quasi-peak. 3. For measurement above 1GHz, the resolution bandwidth is set to 1 MHz and video bandwidth is set to 1 MHz for peak measurement and 10 Hz for average measurement. 4. For 2.4GHz transmitter measurement, the spectrum from 30 MHz to 26GHz is investigated for Low, Mid and High channels. For 5 GHz transmitter measurement, the spectrum from 30 MHz to 40GHz is investigated for Low, Mid and High channels.	
Supplementary information: Radiated emission which fall in the restricted bands must also comply with FCC section 15.209.		
Reference Clause	Part15 C Section 15.247 (d)	
Parameters recorded during the test	Laboratory Ambient Temperature	22 °C
	Relative Humidity	36 %
	Frequency range	Measurement Point
Fully configured sample scanned over the following frequency range	30MHz to 10 th harmonics	Enclosure Port

Configuration Settings

Test Item	Power Interface Mode # (See Section 3.3)	Test Configurations Mode # (See Section 3.6)	EUT Operation Mode # (See 3.5)
Radiated Spurious emission	1	1	1
Conducted Spurious emission	N/A	N/A	N/A
Supplementary information: None			

Limits

According to §15.247(d), in any 100 kHz bandwidth outside the frequency band in which the spread spectrum or digitally modulated intentional radiator is operating, the radio frequency power that is produced by the intentional radiator shall be at least 20 dB below that in the 100 kHz bandwidth within the band that contains the highest level of the desired power, based on either an RF conducted or a radiated measurement, provided the transmitter demonstrates compliance with the peak conducted power limits. If the transmitter complies with the conducted power limits based on the use of RMS averaging over a time interval, as permitted under paragraph(b)(3) of this section, the attenuation required under this paragraph shall be 30 dB instead of 20 dB. Attenuation below the general limits specified in section §15.209(a) is not required. In addition, radiated emission which in the restricted band, as define in section §15.205(a), must also comply the radiated emission limits specified in section §15.209(a) (see section §15.205(c))

According to § 15.209(a), Except as provided elsewhere in this Subpart, the emissions from an intentional radiator shall not exceed the field strength levels specified in the following table:

Frequency (MHz)	Distance (meters)	Field Strength (dBuV/m)	Field Strength (uV/m)
30-88	3	40.0	100
88-216	3	43.5	150
216-960	3	46.0	200
Above 960	3	54.0	500

5.1.1. Radiated Spurious Emissions for Below 1 GHz

Measurement method : Radiated Conducted
 Mode of operation : Continuous Wave

Table 1. Test data for Radiated emission for Below 1 GHz_2.4GHz

Radiated emissions			Ant	Correction factors			Total	Limit	
Frequency (MHz)	Reading (dBuV)	Detect Mode	Pol.	Distance (dB)	AF (dB/m)	Cable loss (dB)	Actual (dBuV/m)	Limit (dBuV/m)	Margin (dB)
134.8	23.74	Q.P.	H	N/A	12.30	2.20	38.25	43.50	5.25
134.8	23.04	Q.P.	V	N/A	12.30	2.20	37.55	43.50	5.95
176.2	22.34	Q.P.	H	N/A	11.96	2.56	36.85	43.50	6.65
190.5	24.76	Q.P.	H	N/A	10.75	2.75	38.25	43.50	5.25
713.4	14.91	Q.P.	H	N/A	21.05	5.89	41.85	46.00	4.15
714.8	17.89	Q.P.	V	N/A	21.07	5.90	44.85	46.00	1.15

Table 2. Test data for Radiated emission for Below 1 GHz_5 GHz

Radiated emissions			Ant	Correction factors			Total	Limit	
Frequency (MHz)	Reading (dBuV)	Detect Mode	Pol.	Distance (dB)	AF (dB/m)	Cable loss (dB)	Actual (dBuV/m)	Limit (dBuV/m)	Margin (dB)
124.8	24.87	Q.P.	H	N/A	11.58	2.10	38.55	43.50	4.95
145.6	22.07	Q.P.	V	N/A	12.86	2.33	37.25	43.50	6.25
167.1	22.33	Q.P.	H	N/A	12.72	2.50	37.55	43.50	5.95
180.4	24.83	Q.P.	V	N/A	11.61	2.62	39.05	43.50	4.45
734.5	15.48	Q.P.	H	N/A	21.37	6.00	42.85	46.00	3.15
734.5	14.92	Q.P.	V	N/A	21.37	6.00	42.29	46.00	3.71

Supplementary information:

-. The frequency spectrum from 30 MHz to 1 000 MHz was investigated. Emission levels are not reported much lower than the limits by over 20 dB. All reading values are peak values.

Remark

- a. To get a maximum emission level from the EUT, the EUT was moved throughout the x-axis, Y-axis and Z-axis. The worst case is Y-axis.
- b. Actual = Reading + AF + CL (AF : Antenna factor, CL : Cable loss)
- c. Distance factor = $20\log(\text{Measurement distance} / \text{The measured distance})$
- d. Margin = Limit (dBuV/m) - Actual (dBuV/m)

5.1.2. Radiated Spurious Emissions for Above 1 GHz

Measurement method : Radiated Conducted
 Mode of operation : Continuous Wave

802.11b

Table 3. Low Channel (2412 MHz)

Radiated emissions			Ant	Correction factors			Total	Limit	
Frequency (MHz)	Reading (dBuV)	Detect Mode	Pol.	Distance (dB)	AF (dB/m)	Amp gain+CL (dB)	Actual (dBuV/m)	Limit (dBuV/m)	Margin (dB)
4824	59.49	Peak	H	N/A	32.87	-36.69	55.67	74.00	18.33
4824	50.13	Average	H	N/A	32.87	-36.69	46.31	54.00	7.69
4824	57.19	Peak	V	N/A	32.87	-36.69	53.37	74.00	20.63
4824	50.21	Average	V	N/A	32.87	-36.69	46.39	54.00	7.61

Table 4. Middle Channel (2437 MHz)

Radiated emissions			Ant	Correction factors			Total	Limit	
Frequency (MHz)	Reading (dBuV)	Detect Mode	Pol.	Distance (dB)	AF (dB/m)	Amp gain+CL (dB)	Actual (dBuV/m)	Limit (dBuV/m)	Margin (dB)
4874	58.15	Peak	H	N/A	33.01	-36.69	54.47	74.00	19.53
4874	51.08	Average	H	N/A	33.01	-36.69	47.40	54.00	6.60
4874	60.38	Peak	V	N/A	33.01	-36.69	56.70	74.00	17.30
4874	47.54	Average	V	N/A	33.01	-36.69	43.86	54.00	10.14

Table 5. High Channel(2462 MHz)

Radiated emissions			Ant	Correction factors			Total	Limit	
Frequency (MHz)	Reading (dBuV)	Detect Mode	Pol.	Distance (dB)	AF (dB/m)	Amp gain+CL (dB)	Actual (dBuV/m)	Limit (dBuV/m)	Margin (dB)
4924	53.78	Peak	H	N/A	33.05	-36.42	50.41	74.00	23.59
4924	42.29	Average	H	N/A	33.05	-36.42	38.92	54.00	15.08
4924	53.49	Peak	V	N/A	33.05	-36.42	50.12	74.00	23.88
4924	43.64	Average	V	N/A	33.05	-36.42	40.27	54.00	13.73

802.11g

Table 6. Low Channel (2412 MHz)

Radiated emissions			Ant	Correction factors			Total	Limit	
Frequency (MHz)	Reading (dBuV)	Detect Mode	Pol.	Distance (dB)	AF (dB/m)	Amp gain+CL (dB)	Actual (dBuV/m)	Limit (dBuV/m)	Margin (dB)
4824	52.31	Peak	H	N/A	32.87	-36.69	48.49	74.00	25.51
4824	39.83	Average	H	N/A	32.87	-36.69	36.01	54.00	17.99
4824	51.63	Peak	V	N/A	32.87	-36.69	47.81	74.00	26.19
4824	39.82	Average	V	N/A	32.87	-36.69	36.00	54.00	18.00

Table 7. Middle Channel (2437 MHz)

Radiated emissions			Ant	Correction factors			Total	Limit	
Frequency (MHz)	Reading (dBuV)	Detect Mode	Pol.	Distance (dB)	AF (dB/m)	Amp gain+CL (dB)	Actual (dBuV/m)	Limit (dBuV/m)	Margin (dB)
4874	60.89	Peak	H	N/A	33.01	-36.69	57.21	74.00	16.79
4874	44.22	Average	H	N/A	33.01	-36.69	40.54	54.00	13.46
4874	59.64	Peak	V	N/A	33.01	-36.69	55.96	74.00	18.04
4874	45.88	Average	V	N/A	33.01	-36.69	42.20	54.00	11.80

Table 8. High Channel (2462 MHz)

Radiated emissions			Ant	Correction factors			Total	Limit	
Frequency (MHz)	Reading (dBuV)	Detect Mode	Pol.	Distance (dB)	AF (dB/m)	Amp gain+CL (dB)	Actual (dBuV/m)	Limit (dBuV/m)	Margin (dB)
4924	65.64	Peak	H	N/A	33.05	-36.42	62.27	74.00	11.73
4924	49.88	Average	H	N/A	33.05	-36.42	46.51	54.00	7.49
4924	64.45	Peak	V	N/A	33.05	-36.42	61.08	74.00	12.92
4924	47.59	Average	V	N/A	33.05	-36.42	44.22	54.00	9.78

802.11n_HT20

Table 9. Low Channel (2412 MHz)

Radiated emissions			Ant	Correction factors			Total	Limit	
Frequency (MHz)	Reading (dBuV)	Detect Mode	Pol.	Distance (dB)	AF (dB/m)	Amp gain+CL (dB)	Actual (dBuV/m)	Limit (dBuV/m)	Margin (dB)
4824	56.37	Peak	H	N/A	32.87	-36.69	52.55	74.00	21.45
4824	46.98	Average	H	N/A	32.87	-36.69	43.16	54.00	10.84
4824	56.92	Peak	V	N/A	32.87	-36.69	53.10	74.00	20.90
4824	46.84	Average	V	N/A	32.87	-36.69	43.02	54.00	10.98

Table 10. Middle Channel (2437 MHz)

Radiated emissions			Ant	Correction factors			Total	Limit	
Frequency (MHz)	Reading (dBuV)	Detect Mode	Pol.	Distance (dB)	AF (dB/m)	Amp gain+CL (dB)	Actual (dBuV/m)	Limit (dBuV/m)	Margin (dB)
4874	56.50	Peak	H	N/A	33.01	-36.69	52.82	74.00	21.18
4874	42.82	Average	H	N/A	33.01	-36.69	39.14	54.00	14.86
4874	59.51	Peak	V	N/A	33.01	-36.69	55.83	74.00	18.17
4874	44.11	Average	V	N/A	33.01	-36.69	40.43	54.00	13.57

Table 11. High Channel (2462 MHz)

Radiated emissions			Ant	Correction factors			Total	Limit	
Frequency (MHz)	Reading (dBuV)	Detect Mode	Pol.	Distance (dB)	AF (dB/m)	Amp gain+CL (dB)	Actual (dBuV/m)	Limit (dBuV/m)	Margin (dB)
4924	57.48	Peak	H	N/A	33.05	-36.42	54.11	74.00	19.89
4924	45.56	Average	H	N/A	33.05	-36.42	42.19	54.00	11.81
4924	59.59	Peak	V	N/A	33.05	-36.42	56.22	74.00	17.78
4924	46.34	Average	V	N/A	33.05	-36.42	42.97	54.00	11.03

802.11n_HT40

Table 12. Low Channel (2422 MHz)

Radiated emissions			Ant	Correction factors			Total	Limit	
Frequency (MHz)	Reading (dBuV)	Detect Mode	Pol.	Distance (dB)	AF (dB/m)	Amp gain+CL (dB)	Actual (dBuV/m)	Limit (dBuV/m)	Margin (dB)
4844	55.79	Peak	H	N/A	33.36	-36.71	52.44	74.00	21.56
4844	45.20	Average	H	N/A	33.36	-36.71	41.85	54.00	12.15
4844	56.73	Peak	V	N/A	33.36	-36.71	53.38	74.00	20.62
4844	47.55	Average	V	N/A	33.36	-36.71	44.20	54.00	9.80

Table 13. Middle Channel (2437 MHz)

Radiated emissions			Ant	Correction factors			Total	Limit	
Frequency (MHz)	Reading (dBuV)	Detect Mode	Pol.	Distance (dB)	AF (dB/m)	Amp gain+CL (dB)	Actual (dBuV/m)	Limit (dBuV/m)	Margin (dB)
4874	57.63	Peak	H	N/A	33.01	-36.69	53.95	74.00	20.05
4874	46.63	Average	H	N/A	33.01	-36.69	42.95	54.00	11.05
4874	57.70	Peak	V	N/A	33.01	-36.69	54.02	74.00	19.98
4874	47.58	Average	V	N/A	33.01	-36.69	43.90	54.00	10.10

Table 14. High Channel (2452 MHz)

Radiated emissions			Ant	Correction factors			Total	Limit	
Frequency (MHz)	Reading (dBuV)	Detect Mode	Pol.	Distance (dB)	AF (dB/m)	Amp gain+CL (dB)	Actual (dBuV/m)	Limit (dBuV/m)	Margin (dB)
4904	59.48	Peak	H	N/A	33.13	-36.59	56.02	74.00	17.98
4904	45.81	Average	H	N/A	33.13	-36.59	42.35	54.00	11.65
4904	57.55	Peak	V	N/A	33.13	-36.59	54.09	74.00	19.91
4904	46.83	Average	V	N/A	33.13	-36.59	43.37	54.00	10.63

802.11a

Table 15. Low Channel (5745 MHz)

Radiated emissions			Ant	Correction factors			Total	Limit	
Frequency (MHz)	Reading (dBuV)	Detect Mode	Pol.	Distance (dB)	AF (dB/m)	Amp gain+CL (dB)	Actual (dBuV/m)	Limit (dBuV/m)	Margin (dB)
11490	54.80	Peak	H	N/A	38.22	-32.67	60.35	74.00	13.65
11490	37.41	Average	H	N/A	38.22	-32.67	42.96	54.00	11.04
11490	53.30	Peak	V	N/A	38.22	-32.67	58.85	74.00	15.15
11490	40.89	Average	V	N/A	38.22	-32.67	46.44	54.00	7.56

Table 16. Middle Channel (5785 MHz)

Radiated emissions			Ant	Correction factors			Total	Limit	
Frequency (MHz)	Reading (dBuV)	Detect Mode	Pol.	Distance (dB)	AF (dB/m)	Amp gain+CL (dB)	Actual (dBuV/m)	Limit (dBuV/m)	Margin (dB)
11570	54.71	Peak	H	N/A	38.20	-34.95	57.96	74.00	16.04
11570	40.21	Average	H	N/A	38.20	-34.95	43.46	54.00	10.54
11570	55.84	Peak	V	N/A	38.20	-34.95	59.09	74.00	14.91
11570	42.71	Average	V	N/A	38.20	-34.95	45.96	54.00	8.04

Table 17. High Channel (5825 MHz)

Radiated emissions			Ant	Correction factors			Total	Limit	
Frequency (MHz)	Reading (dBuV)	Detect Mode	Pol.	Distance (dB)	AF (dB/m)	Amp gain+CL (dB)	Actual (dBuV/m)	Limit (dBuV/m)	Margin (dB)
11650	53.39	Peak	H	N/A	38.20	-35.20	56.39	74.00	17.61
11650	37.14	Average	H	N/A	38.20	-35.20	40.14	54.00	13.86
11650	60.72	Peak	V	N/A	38.20	-35.20	63.72	74.00	10.28
11650	39.97	Average	V	N/A	38.20	-35.20	42.97	54.00	11.03

802.11a_HT20

Table 18. Low Channel (5745 MHz)

Radiated emissions			Ant	Correction factors			Total	Limit	
Frequency (MHz)	Reading (dBuV)	Detect Mode	Pol.	Distance (dB)	AF (dB/m)	Amp gain+CL (dB)	Actual (dBuV/m)	Limit (dBuV/m)	Margin (dB)
11490	47.83	Peak	H	N/A	38.22	-32.67	53.38	74.00	20.62
11490	33.86	Average	H	N/A	38.22	-32.67	39.41	54.00	14.59
11490	58.23	Peak	V	N/A	38.22	-32.67	63.78	74.00	10.22
11490	40.23	Average	V	N/A	38.22	-32.67	45.78	54.00	8.22

Table 19. Middle Channel (5785 MHz)

Radiated emissions			Ant	Correction factors			Total	Limit	
Frequency (MHz)	Reading (dBuV)	Detect Mode	Pol.	Distance (dB)	AF (dB/m)	Amp gain+CL (dB)	Actual (dBuV/m)	Limit (dBuV/m)	Margin (dB)
11570	45.57	Peak	H	N/A	38.20	-34.95	48.82	74.00	25.18
11570	30.09	Average	H	N/A	38.20	-34.95	33.34	54.00	20.66
11570	54.59	Peak	V	N/A	38.20	-34.95	57.84	74.00	16.16
11570	39.73	Average	V	N/A	38.20	-34.95	42.98	54.00	11.02

Table 20. High Channel (5825 MHz)

Radiated emissions			Ant	Correction factors			Total	Limit	
Frequency (MHz)	Reading (dBuV)	Detect Mode	Pol.	Distance (dB)	AF (dB/m)	Amp gain+CL (dB)	Actual (dBuV/m)	Limit (dBuV/m)	Margin (dB)
11650	48.57	Peak	H	N/A	38.20	-35.20	51.57	74.00	22.43
11650	31.32	Average	H	N/A	38.20	-35.20	34.32	54.00	19.68
11650	55.16	Peak	V	N/A	38.20	-35.20	58.16	74.00	15.84
11650	40.07	Average	V	N/A	38.20	-35.20	43.07	54.00	10.93

802.11a_HT40

Table 21. Low Channel (5755 MHz)

Radiated emissions			Ant	Correction factors			Total	Limit	
Frequency (MHz)	Reading (dBuV)	Detect Mode	Pol.	Distance (dB)	AF (dB/m)	Amp gain+CL (dB)	Actual (dBuV/m)	Limit (dBuV/m)	Margin (dB)
11510	45.81	Peak	H	N/A	38.21	-32.51	51.51	74.00	22.49
11510	29.83	Average	H	N/A	38.21	-32.51	35.53	54.00	18.47
11510	54.12	Peak	V	N/A	38.21	-32.51	59.82	74.00	14.18
11510	41.41	Average	V	N/A	38.21	-32.51	47.11	54.00	6.89

Table 22. High Channel (5795 MHz)

Radiated emissions			Ant	Correction factors			Total	Limit	
Frequency (MHz)	Reading (dBuV)	Detect Mode	Pol.	Distance (dB)	AF (dB/m)	Amp gain+CL (dB)	Actual (dBuV/m)	Limit (dBuV/m)	Margin (dB)
11590	46.37	Peak	H	N/A	38.21	-35.01	49.57	74.00	24.43
11590	30.89	Average	H	N/A	38.21	-35.01	34.09	54.00	19.91
11590	55.96	Peak	V	N/A	38.21	-35.01	59.16	74.00	14.84
11590	38.60	Average	V	N/A	38.21	-35.01	41.80	54.00	12.20

Supplementary information:

-. Measuring frequencies from 1 GHz to the 10th harmonic of highest fundamental Frequency. Radiated emissions measured in frequency above 1 000 MHz were made with an instrument using peak/average detector mode.

Remark

- “*” means the restricted band.
- Average test would be performed if the peak result were greater than the average limit.
- To get a maximum emission level from the EUT, the EUT was moved throughout the x-axis, Y-axis and Z-axis. The worst case is Y -axis.
- Actual = Reading + AF + AMP + CL (AF : Antenna factor, AMP : Amp gain, CL : Cable loss)
- Distance factor = $20\log(\text{Measurement distance} / \text{The measured distance})$
- Margin = Limit (dBuV/m) - Actual (dBuV/m)

5.1.3. Radiated Restricted Band Edge Measurements

Measurement method : Radiated Conducted
 Mode of operation : Continuous Wave

Table 23. Measurement for restricted band of 11b

Radiated emissions			Ant	Correction factors			Total	Limit	
Frequency (MHz)	Reading (dBuV)	Detect Mode	Pol.	Distance (dB)	AF (dB/m)	Cable loss (dB)	Actual (dBuV/m)	Limit (dBuV/m)	Margin (dB)
2385.73	27.33	Peak	V	N/A	28.04	6.31	61.68	74.00	12.32
2386.67	14.06	Average	V	N/A	28.04	6.31	48.41	54.00	5.59
2346.53	26.53	Peak	H	N/A	27.87	6.19	60.59	74.00	13.41
2386.53	14.05	Average	H	N/A	28.04	6.31	48.40	54.00	5.60
2487.68	26.64	Peak	V	N/A	28.32	6.56	61.52	74.00	12.48
2487.52	13.66	Average	V	N/A	28.32	6.56	48.54	54.00	5.46
2495.00	26.67	Peak	H	N/A	28.34	6.56	61.57	74.00	12.43
2487.10	13.63	Average	H	N/A	28.32	6.56	48.51	54.00	5.49

Table 24. Measurement for restricted band of 11g

Radiated emissions			Ant	Correction factors			Total	Limit	
Frequency (MHz)	Reading (dBuV)	Detect Mode	Pol.	Distance (dB)	AF (dB/m)	Cable loss (dB)	Actual (dBuV/m)	Limit (dBuV/m)	Margin (dB)
2389.33	27.18	Peak	V	N/A	28.04	6.30	61.52	74.00	12.48
2390.00	14.31	Average	V	N/A	28.05	6.30	48.66	54.00	5.34
2390.00	27.07	Peak	H	N/A	28.05	6.30	61.42	74.00	12.58
2389.33	14.24	Average	H	N/A	28.04	6.30	48.58	54.00	5.42
2484.19	31.01	Peak	V	N/A	28.31	6.56	65.88	74.00	8.12
2483.50	15.02	Average	V	N/A	28.31	6.56	49.89	54.00	4.11
2484.27	32.18	Peak	H	N/A	28.31	6.56	67.05	74.00	6.95
2483.64	15.10	Average	H	N/A	28.31	6.56	49.97	54.00	4.03

Table 25. Measurement for restricted band of 11n (HT20)

Radiated emissions			Ant	Correction factors			Total	Limit	
Frequency (MHz)	Reading (dBuV)	Detect Mode	Pol.	Distance (dB)	AF (dB/m)	Cable loss (dB)	Actual (dBuV/m)	Limit (dBuV/m)	Margin (dB)
2389.87	26.36	Peak	V	N/A	28.04	6.3	60.70	74.00	13.30
2390.00	14.14	Average	V	N/A	28.05	6.3	48.49	54.00	5.51
2389.07	27.51	Peak	H	N/A	28.04	6.3	61.85	74.00	12.15
2390.00	14.22	Average	H	N/A	28.05	6.3	48.57	54.00	5.43
2483.61	31.46	Peak	V	N/A	28.31	6.56	66.33	74.00	7.67
2483.58	15.31	Average	V	N/A	28.31	6.56	50.18	54.00	3.82
2483.75	31.88	Peak	H	N/A	28.31	6.56	66.75	74.00	7.25
2483.56	15.29	Average	H	N/A	28.31	6.56	50.16	54.00	3.84

Table 26. Measurement for restricted band of 11n (HT40)

Radiated emissions			Ant	Correction factors			Total	Limit	
Frequency (MHz)	Reading (dBuV)	Detect Mode	Pol.	Distance (dB)	AF (dB/m)	Cable loss (dB)	Actual (dBuV/m)	Limit (dBuV/m)	Margin (dB)
2337.73	26.70	Peak	V	N/A	27.80	6.20	60.70	74.00	13.30
2385.73	13.33	Average	V	N/A	28.04	6.31	47.68	54.00	6.32
2384.13	25.89	Peak	H	N/A	28.04	6.31	60.24	74.00	13.76
2385.47	13.30	Average	H	N/A	28.04	6.31	47.65	54.00	6.35
2483.53	34.84	Peak	V	N/A	28.31	6.56	69.71	74.00	4.29
2484.30	14.28	Average	V	N/A	28.31	6.56	49.15	54.00	4.85
2483.97	34.38	Peak	H	N/A	28.31	6.56	69.25	74.00	4.75
2490.93	14.84	Average	H	N/A	28.33	6.56	49.73	54.00	4.27

5.1.1. Receiving mode Radiated Spurious Emissions for Below 1 GHz**Table 27. Test data for Radiated emission for Below 1 GHz_5 GHz**

Frequency [MHz]	Reading [dBuV]	Pol	Angle	Height [m]	Correction Factor (dB)			Data [dBuV/m]	Limits [dB]	Margin [dB]
					Amp. Gain	Antenna	Cable			
36.702	20.1	V	15	100	23.1	15.7	1.1	13.8	40	26.2
36.019	27.9	V	300	110	23.1	16.1	1	21.9	40	18.1
167.85	29.6	V	295	115	23.2	10.1	2.1	18.6	40	21.4
557.569	29	V	150	120	24.8	18.3	4.1	26.6	47	20.4
606.424	25.6	V	230	150	24.6	18.8	4.4	24.2	47	22.8

Supplementary information: If no frequencies are specified in the tables, no measurement for quasi-peak was necessary.

Table 28. Test data for Radiated emission for Below 1 GHz_5 GHz

Frequency [MHz]	Reading [dBuV]	Pol	Angle	Height [m]	Correction Factor (dB)			Data [dBuV/m]	Limits [dB]	Margin [dB]
					Amp. Gain	Antenna	Cable			
36.10	21.7	H	8	105	23.1	15.7	1.1	15.4	40.0	24.6
36.20	28.2	V	120	143	23.1	16.1	1.0	22.2	40.0	17.8
167.85	30.5	V	295	285	23.2	10.1	2.1	19.5	40.0	20.5
557.60	28.7	V	185	285	24.8	18.3	4.1	26.3	47.0	20.7
606.52	27.6	H	143	214	24.6	18.8	4.4	26.2	47.0	20.8

Supplementary information: If no frequencies are specified in the tables, no measurement for quasi-peak was necessary.

Supplementary information:

- The frequency spectrum from 30 MHz to 1000 MHz was investigated. Emission levels are not reported much lower than the limits by over 20 dB. All reading values are peak values.

Remark

1. The field strength of spurious emission was measured in the following position: EUT stand-up position(Z axis), lie-down position(X,Y axis). The worst emission was found in stand-up position(Z axis) and the worst case was recorded.

5.1.2. Receiving mode Radiated Spurious Emissions for Above 1 GHz

Measurement method : Radiated Conducted
 Mode of operation : Receiving mode

802.11g

Table 29. Low Channel (2412 MHz)

Frequency [MHz]	Reading	Pol.	Correction Factor		Limits	Result	Margin
	[dBuV/m]		[dB]		[dBuV/m]	[dBuV/m]	[dB]
	AV / Peak		Ant	CL+Amp	AV / Peak	AV / Peak	AV / Peak
No emissions were detected at a level greater than 20dB below limit.							

Table 30. Middle Channel (2437 MHz)

Frequency [MHz]	Reading	Pol.	Correction Factor		Limits	Result	Margin
	[dBuV/m]		[dB]		[dBuV/m]	[dBuV/m]	[dB]
	AV / Peak		Ant	CL+Amp	AV / Peak	AV / Peak	AV / Peak
No emissions were detected at a level greater than 20dB below limit.							

Table 31. High Channel (2462 MHz)

Frequency [MHz]	Reading	Pol.	Correction Factor		Limits	Result	Margin
	[dBuV/m]		[dB]		[dBuV/m]	[dBuV/m]	[dB]
	AV / Peak		Ant	CL+Amp	AV / Peak	AV / Peak	AV / Peak
No emissions were detected at a level greater than 20dB below limit.							

802.11n_HT20_2.4GHz

Table 32. Low Channel (2412 MHz)

Frequency [MHz]	Reading [dBuV/m] AV / Peak	Pol.	Correction Factor [dB]		Limits [dBuV/m] AV / Peak	Result [dBuV/m] AV / Peak	Margin [dB] AV / Peak
			Ant	CL+Amp			
No emissions were detected at a level greater than 20dB below limit.							

Table 33. Middle Channel (2437 MHz)

Frequency [MHz]	Reading [dBuV/m] AV / Peak	Pol.	Correction Factor [dB]		Limits [dBuV/m] AV / Peak	Result [dBuV/m] AV / Peak	Margin [dB] AV / Peak
			Ant	CL+Amp			
No emissions were detected at a level greater than 20dB below limit.							

Table 34. High Channel (2462 MHz)

Frequency [MHz]	Reading [dBuV/m] AV / Peak	Pol.	Correction Factor [dB]		Limits [dBuV/m] AV / Peak	Result [dBuV/m] AV / Peak	Margin [dB] AV / Peak
			Ant	CL+Amp			
No emissions were detected at a level greater than 20dB below limit.							

802.11n_HT40_2.4GHz

Table 35. Low Channel (2422 MHz)

Frequency [MHz]	Reading [dBuV/m]	Pol.	Correction Factor [dB]		Limits [dBuV/m]	Result [dBuV/m]	Margin [dB]
	AV / Peak		Ant	CL+Amp	AV / Peak	AV / Peak	AV / Peak
No emissions were detected at a level greater than 20dB below limit.							

Table 36. Middle Channel (2437 MHz)

Frequency [MHz]	Reading [dBuV/m]	Pol.	Correction Factor [dB]		Limits [dBuV/m]	Result [dBuV/m]	Margin [dB]
	AV / Peak		Ant	CL+Amp	AV / Peak	AV / Peak	AV / Peak
No emissions were detected at a level greater than 20dB below limit.							

Table 37. High Channel (2452 MHz)

Frequency [MHz]	Reading [dBuV/m]	Pol.	Correction Factor [dB]		Limits [dBuV/m]	Result [dBuV/m]	Margin [dB]
	AV / Peak		Ant	CL+Amp	AV / Peak	AV / Peak	AV / Peak
No emissions were detected at a level greater than 20dB below limit.							

802.11a

Table 38. Low Channel (5745 MHz)

Frequency [MHz]	Reading [dBuV/m]	Pol.	Correction Factor [dB]		Limits [dBuV/m]	Result [dBuV/m]	Margin [dB]
	AV / Peak		Ant	CL+Amp	AV / Peak	AV / Peak	AV / Peak
No emissions were detected at a level greater than 20dB below limit.							

Table 39. Middle Channel (5785 MHz)

Frequency [MHz]	Reading [dBuV/m]	Pol.	Correction Factor [dB]		Limits [dBuV/m]	Result [dBuV/m]	Margin [dB]
	AV / Peak		Ant	CL+Amp	AV / Peak	AV / Peak	AV / Peak
No emissions were detected at a level greater than 20dB below limit.							

Table 40. High Channel (5825 MHz)

Frequency [MHz]	Reading [dBuV/m]	Pol.	Correction Factor [dB]		Limits [dBuV/m]	Result [dBuV/m]	Margin [dB]
	AV / Peak		Ant	CL+Amp	AV / Peak	AV / Peak	AV / Peak
No emissions were detected at a level greater than 20dB below limit.							

802.11n_HT20_5GHz

Table 41. Low Channel (5745 MHz)

Frequency [MHz]	Reading [dBuV/m]	Pol.	Correction Factor [dB]		Limits [dBuV/m]	Result [dBuV/m]	Margin [dB]
	AV / Peak		Ant	CL+Amp	AV / Peak	AV / Peak	AV / Peak
No emissions were detected at a level greater than 20dB below limit.							

Table 42. Middle Channel (5785 MHz)

Frequency [MHz]	Reading [dBuV/m]	Pol.	Correction Factor [dB]		Limits [dBuV/m]	Result [dBuV/m]	Margin [dB]
	AV / Peak		Ant	CL+Amp	AV / Peak	AV / Peak	AV / Peak
No emissions were detected at a level greater than 20dB below limit.							

Table 43. High Channel (5825 MHz)

Frequency [MHz]	Reading [dBuV/m]	Pol.	Correction Factor [dB]		Limits [dBuV/m]	Result [dBuV/m]	Margin [dB]
	AV / Peak		Ant	CL+Amp	AV / Peak	AV / Peak	AV / Peak
No emissions were detected at a level greater than 20dB below limit.							

802.11n_HT40_5GHz

Table 44. Low Channel (5755 MHz)

Frequency [MHz]	Reading [dBuV/m] AV / Peak	Pol.	Correction Factor [dB]		Limits [dBuV/m] AV / Peak	Result [dBuV/m] AV / Peak	Margin [dB] AV / Peak
			Ant	CL+Amp			
No emissions were detected at a level greater than 20dB below limit.							

Table 45. High Channel (5795 MHz)

Frequency [MHz]	Reading [dBuV/m] AV / Peak	Pol.	Correction Factor [dB]		Limits [dBuV/m] AV / Peak	Result [dBuV/m] AV / Peak	Margin [dB] AV / Peak
			Ant	CL+Amp			
No emissions were detected at a level greater than 20dB below limit.							