

Electromagnetic Emission

FCC MEASUREMENT REPORT

CERTIFICATION OF COMPLIANCE

FCC Part 15 Certification Measurement

PRODUCT : SET-TOP BOX
MODEL/TYPE NO : DMS2444UHDS / NONE
FCC ID : PFNDMS2444UHDS
MULTIPLE MODEL : -
BRAND NAME : COX
APPLICANT : Digital Multimedia Technology Co., Ltd.
2nd Fl., 926 Gwanyang-Dong, Dongan-Gu, Anyang-Si,
Gyeonggi-Do, 431-060 Korea
Attn.: Jung Hwan Lee / Senior Research Engineer
MANUFACTURER : Hengdi Digital Technology (Shen Zhen) Co.,Ltd
A.B Building, Xin Shi Qiao Guanjie Industrial Park, Guihua Community,
Guanlan Street, Bao'an District, Shenzhen City, Guangdong Province,
China, 518-110
FCC CLASSIFICATION : HID - Part 15 TV Interface Device
RULE PART(S) : FCC Part 15 Subpart B
TEST PROCEDURE : ANSI C63.4-2009
TEST REPORT No. : ETLE160523.0452
DATES OF TEST : May 31, 2016 to June 07, 2016
REPORT ISSUE DATE : June 13, 2016
TEST LABORATORY : ETL Inc. (FCC Designation Number: KR0022)

This SET-TOP BOX, Model DMS2444UHDS has been tested in accordance with the measurement procedures specified in ANSI C63.4-2009 at the ETL/EMC Test Laboratory and has been shown to be complied with the electromagnetic radiated emission limits specified in FCC Rule Part15 Subpart B:

I attest to the accuracy of data. All measurement herein was performed by me or was made under my supervision and is correct to the best of my knowledge and belief. I assume full responsibility for the completeness of these measurements and vouch for the qualifications of all persons taking them.

The results of testing in this report apply to the product/system which was tested only. Other similar equipment will not necessarily produce the same results due to production tolerance and measurement uncertainties.

Prepared by:

Chul Min, Ji (Test Engineer)

June 13, 2016

Reviewed by:

Hyung Min, Choi (Chief Engineer)

June 13, 2016

ETL Inc.

Head office: #371-51, Gasan-dong, Geumcheon-gu, Seoul, 153-803, Korea

Open site: #499-1, Sagot-ri, Seosin-myeon, Hwaseong-si, Gyeonggi-do, 445-882, Korea

Tel: 82-2-858-0786 Fax: 82-2-858-0788

The test report merely corresponds to the test sample(s).

This report shall not be reproduced, in whole or in part without the written approval of ETL Inc.

Table of Contents

FCC Measurement Report

- 1. Introduction**
- 2. Product Information**
- 3. Description of Tests**
- 4. Test Condition**
- 5. Test Results**
 - 5.1 Summary of Test Results**
 - 5.2 AC Power line Conducted Emissions Measurement**
 - 5.3 Radiated Emissions Measurement**
 - 5.4 Antenna Power Conduction Measurement**
 - 5.5 Output Signal Level Measurement**
 - 5.6 Output Terminal Conducted Spurious Emission Measurement**
 - 5.7 Antenna Transfer Switch Measurement**
- 6. Sample Calculation**
- 7. List of test Equipment used for Measurement**

Appendix A. FCC Label and Location

Appendix B. Test Setup Photographs

Appendix C. External Photographs

Appendix D. Internal Photographs

FCC MEASUREMENT REPORT

Scope – Measurement and determination of electromagnetic emission(EME) of radio frequency devices including intentional radiators and/or unintentional radiators for compliance with the technical rules and regulations of the U.S Federal Communications Commission(FCC)

General Information

Applicant Name : Digital Multimedia Technology Co., Ltd.

Address : 2nd Fl., 926 Gwanyang-Dong, Dongan-Gu, Anyang-Si,
Gyeonggi-Do, 431-060 Korea

Attention : Jung Hwan Lee / Senior Research Engineer

- **EUT Type** : SET-TOP BOX
- **Model Number** : DMS2444UHDS
- **S/N** : NONE
- **Rule Part(s)** : FCC Part 15 Subpart B
- **Test Procedure** : ANSI C63.4-2009
- **FCC Classification** : HID - Part 15 TV Interface Device
- **Dates of Tests** : May 31, 2016 to June 07, 2016
- **Environmental of Tests** : Temperature: (24.1 ± 3.6) °C
Humidity: (51 ± 14) % R.H.
Atmospheric Pressure: (101.0 ± 0.5) kPa
- **Place of Tests** : ETL Inc. Testing Lab. (FCC Designation Number : KR0022)

Radiated Emission test 1;
#499-1, Sagot-ri, Seosin-myeon, Hwaseong-si,
Gyeonggi-do, 445-882, Korea

Radiated Emission test 2 and Conducted Emission test;
#371-51, Gasan-dong, Geumcheon-gu, Seoul, 153-803, Korea
- **Test Report No.** : ETLE160523.0452

1. INTRODUCTION

The measurement tests for radiated and conducted emission test were conducted at the ETL Inc. The site is constructed in conformance with the requirements of the ANSI C63.4-2009 and CISPR Publication 16. The ETL has site descriptions on file with the FCC for 3 m and 10 m site configurations. Detailed description of test facility was found to be in compliance with the requirements of Section 2.948 FCC Rules according to the ANSI C63.4-2009 and registered to the Federal Communications Commission (FCC Designation Number : KR0022).

The measurement procedure described in American National Standard for Method of Measurement of Radio-Noise Emission from Low-Voltage Electrical and Electronic Equipment in the Range of 9 kHz to 40 GHz (ANSI C63.4-2009) was used in determining radiated and conducted emissions from the Digital Multimedia Technology Co., Ltd., Model: DMS2444UHDS.



2. PRODUCT INFORMATION

2.1 Equipment Description

The Equipment Under Test (EUT) is the SET-TOP BOX (model: DMS2444UHDS).

The model DMS2444UHDS is basic model that was tested.

Change of AC/DC Adapter. (Change the level of efficiency of the AC/DC Adapter.)

| Model name of AC/DC Adapter | Before | After |
|-----------------------------|---|---|
| EDF0500150A1BB | <p style="text-align: center;">EFFICIENCY LEVEL: V</p>  | <p style="text-align: center;">EFFICIENCY LEVEL: VI</p>  |

2.2 General Specification

- General Features

| |
|--|
| MPEG-2 / ,[EG-4 Part 10 / H.264 |
| Video Display format with NTSC / 480p / 576p / 720p / 1 080i |
| Favorite channel, Parental Lock |
| Dolby Digital AC3 |
| HDMI 1.3a with HDCP 1.1 |
| Automatic search for newly added transponder (Network Auto Search) |
| Stores up to 5 000 channels |
| Plug-and-play data transfer system (DSR to DSR) |
| Timer function, automatically turns On/Off by setting function (daily, weekly, monthly and one time) |
| Automatic reserved channel moving system |
| Provide Electronic Program Guide (EPG) |
| More than 800 pages OSD Teletext (DVB ETS 300 706) and Subtitle function support |
| Support for various video output: HDMI, RF 3/4 Mod. |
| 256 colors On-Screen-Display |
| PAL/NTSC automatically conversion |
| Last channel automatically saving |
| High Internal Frequency: CPU Clock → 432 MHz |

- Engineering Specification

| Front-End | | |
|---|---|---|
| Tuner Input | Input frequency | 105 MHz to 1 002 MHz |
| | Connector | F-Type (1 Input) |
| Demodulator | Demodulation type | Demodulation and FEC decoding in accordance with ITU-T J.83 Annex-A/B/C |
| | | Demodulation: 64 / 256 - QAM |
| Demultiplexing | | |
| In accordance with ISO 13818-1 | | |
| - Maximum input band transport stream rate supported is 100 Mbps. | | |
| - Maximum combined transport stream burst rate can be greater than 262 Mbps based on usage. | | |
| - Maximum combined transport stream average rate after PID filtering is 262 Mbps. | | |
| - Supports 256 PID filters via 128 PID channels. | | |
| Video Processing | | |
| Decompression | H.264/AVC main and high profile to level 4.1 | |
| | VC-1 advanced profile @ level 3 | |
| | VC-1 simple and main profile | |
| | HD MPEG-2 and SD MPEG-2 | |
| | AVC / MPEG-2 / VC-1 still picture decode simultaneous with live decode | |
| Video buffer | 512 Mbit of DDR DRAM is provided | |
| Video output | 480i / 480p / 576i / 576p / 720p / 1 080i / 1 080p (24 Hz/30 Hz) output formats | |
| | Macrovision 7.1 Support | |
| Video format | 4:3, 16:9 | |
| Audio Processing | | |
| Decompression | MPEG I Layer 1, 2 / MPEG I Layer 3 (MP3) | |
| | AAC LC, AAC LC+ SBR Level 2, AAC+ Level 2, AAC+ Level 4 | |
| | Dolby Digital, Dolby Digital Plus | |
| Output | Windows Media Audio (WMA) | |
| | Stereo Channel | |
| | Dual Mono | |
| | Joint Stereo Channel | |
| | Mono | |
| | Spdif with AC-3 | |

| Baseband Inputs / Outputs | | |
|----------------------------------|---|-----------------------------|
| RF Output Signal | NTSC | |
| Video Carrier Frequency | (61.25 ± 90) kHz US 3 CH | |
| | (67.25 ± 90) kHz US 4 CH | |
| | IEC169-24, 1 x F-Type | |
| HDMI Outputs | | |
| Connector type | 1 x HDMI 1.3a | |
| | 19 pin Type-A HDMI connect | |
| Microprocessor | | |
| Microprocessor | BCM7572QKFEB03G | |
| Clock Frequency | 432 MHz | |
| DDR-RAM Memory | 128 Mbyte (DDR2-RAM 1 G x 1) | |
| Flash memory | 16 Mbyte (Serial Flash) | |
| Remote Control Unit | | |
| Transmission Type | Infrared | |
| Number of KEYS | 21 keys | |
| Operating distance | 15 m | |
| Battery | AA | |
| Power Supply | | |
| Type | Wallmount Type External Adapter (100 V ~ 120 V AC @ 50 Hz/60 Hz, 0.18 A) | |
| Main Output voltage | 5 V DC, 1.5 A | |
| Nominal power consumption | 5 Watts | |
| Physical Characteristics | | |
| Front Panel | Display | 2 color LED |
| Rear Panel | Connectors | 1 RF Input (F-type) |
| | | 1 x CH 3/4 (Slide Switch) |
| | | 1 x RF Modulator (1 F-type) |
| | | 1 x IR Input (3.5 mm) |
| | | 1 x HDMI |
| | | 1 x DC Power Jack |

3. DESCRIPTION OF TESTS

3.1 AC Power line Conducted Emission Measurement

AC Power line Conducted emissions measurements were made in accordance with section 12, "Measurement of unintentional radiators other than ITE" of ANSI C63.4-2009. The measurements were performed over the frequency range of 0.15 MHz to 30 MHz using a 50 Ω /50 μ H LISN as the input transducer to a Spectrum Analyzer or a Test Receiver. The measurements were made with the detector set for "Peak" amplitude within a bandwidth of 9 kHz or for "quasi-peak" within a bandwidth of 9 kHz.

The line-conducted emission test is conducted inside a shielded anechoic chamber room with 1 m x 1.5 m x 0.8 m wooden table which is placed 40 cm away from the vertical wall and 1.5 m away from the side wall of the chamber room. Two LISN are bonded to the shielded room. The EUT is powered from the LISN and the support equipment is powered from the other LISN. Powers to the LISNs are filtered by a noise cut power line filters. If the EUT is a DC-powered device, power will be derived from the source power supply it normally will be powered from and these supply lines will be connected to the LISN.

Non-inductive bundling to a 1 m length shortened all interconnecting cables more than 1 m. Sufficient time for the EUT, support equipment, and test equipment was allowed in order for them to warm up to their normal operating condition. The RF output of the LISN was connected to the EMI Test Receiver to determine the frequency producing the maximum emission from the EUT. The frequency producing the maximum level was reexamined using to set Quasi-Peak mode by manual, after scanned by automatic Peak mode from 0.15 MHz to 30 MHz. The bandwidth of the spectrum analyzer was set to 9 kHz. The EUT, support equipment, and interconnecting cables were arranged and manipulated to maximize each emission.

Photographs of the worst-case emission can be seen in photographs of conducted emission test setup in Appendix B.

3.2 Radiated Emission Measurement

Radiated emission measurements were made in accordance with section 12, "Measurement of unintentional radiators other than ITE" of ANSI C63.4-2009. The measurements were performed over the frequency range of 30 MHz to 40 GHz (or 5th harmonic of the highest frequency) in using antenna as the input transducer to a spectrum analyzer or a field intensity meter. The measurements below 1 GHz were made with the detector set for "Quasi-peak" within a bandwidth of 120 kHz. The measurements above 1 GHz were made with the detector set for "Peak and Average" within a bandwidth of 1 MHz.

Preliminary measurements were made at 3 m using broadband antennas, and spectrum analyzer to determined the frequency producing the maximum emission in shielded room. Appropriate precaution was taken to ensure that all emission from the EUT were maximized and investigated. The system configuration, mode of operation, turntable azimuth and height with respect to the antenna were noted for each frequency found. The spectrum was scanned from 30 MHz to 1 000 MHz using Log-Bicon antenna. Above 1 GHz, linearly polarized double ridge horn antennas were used. Final measurements were made open site or SVSWR chamber at 3 m. The test equipment was placed on a styrofoam table. Sufficient time for the EUT, support equipment, and test equipment was allowed in order for them to warm up to their normal operating condition. Each frequency found during pre-scan measurements was re-examined by manual. The EUT, support equipment and interconnecting cables were re-configured to the set-up producing the maximum emission for the frequency and were placed on top of a 0.8 m high nonmetallic 1 m x 1.5 m table. The EUT, support equipment, and interconnecting cables were re-arranged and manipulated to maximize each emission. The turntable containing the system was rotated; the antenna height was varied 1 m to 4 m and stopped at the azimuth or height producing the maximum emission. Each emission was maximized by: varying the mode of operation to the EUT and/or support equipment and changing the polarity of the antenna, whichever determined the worst-case emission.

Photographs of the worst-case emission can be seen in Photographs of the worst-case emission test setup can be seen in Appendix B.

3.3 Antenna Power Conducted Measurements

Power on the receive antenna terminals was to be determined by measurement of the voltage present at these terminals. An antenna-conducted power measurement is performed with the EUT antenna terminals connected directly to a spectrum analyzer, if the antenna impedance matches the impedance of the measuring instrument. Otherwise, use an impedance-matching network to connect the measuring instrument to the antenna terminals of the EUT. Losses in decibels in any impedance-matching network used are added to the measured value in dB μ V.

With the EUT tuned to one of the frequency over which device operates, measure both the frequency and voltage present at the antenna input terminals over the frequency range specified in the individual equipment requirements. Repeat this measurement with the receiver tuned to another frequency until the numbers of frequencies specified have been successively measured. Power on the receive antenna terminals is the ratio of V^2/R , where V is the loss-corrected voltage measured at the antenna terminals, and R is the impedance of the measuring instrument.

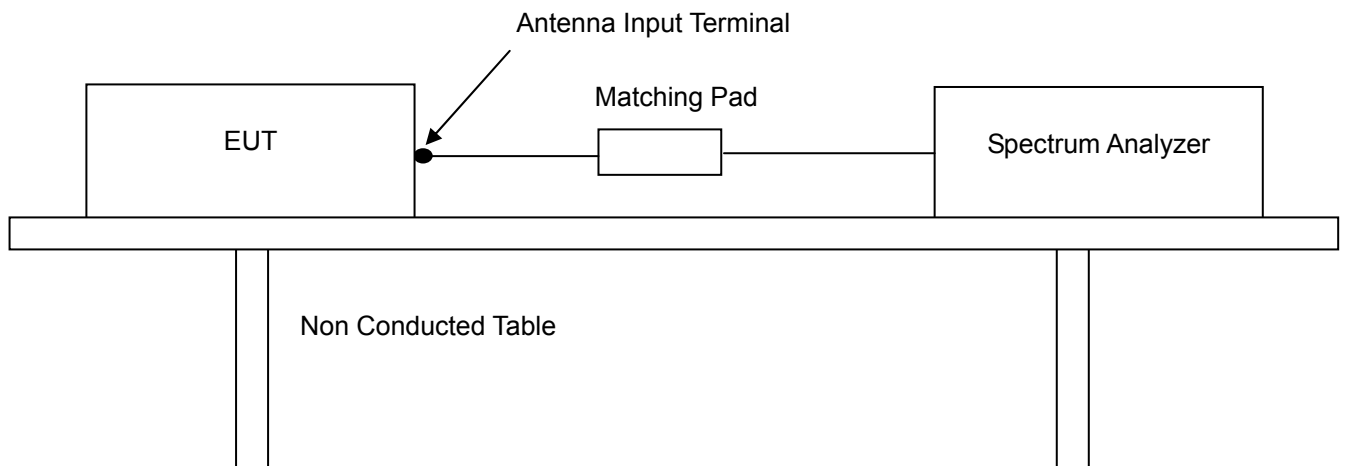

3.4 Output Signal Conducted Level Measurement

The output signal level is the maximum voltage level present at the output terminals of the EUT on a particular frequency during normal use of the device.

The signal level was measured by direct connection to the spectrum analyzer with 50 ohm/75 ohm matching transformer between the spectrum analyzer and the TV interface device. The RF output signal level measured was the highest RF level present at the output terminals during normal use of the device. Measurements were made of the levels of both the visual and audio carrier for each TV channel (3 and 4) on which the device operates. The Satellite Receiver was supported between the EUT and the measuring instrument in a straight horizontal line so it had at least 75 cm clearance from any conducting surface.

The EUT is provided with a typical signal consistent with normal operation. For each channel on which the EUT operates and in each mode in which the device operates, the video and audio carrier level is measured and recorded.

The voltage corresponding to the peak envelope power of the video modulated signal during maximum amplitude peaks across a resistance (R ohms) matching the rated output impedance of the device, must not exceed $692.8 R^{1/2} \mu\text{V}$ for all other TV interface device. The voltage corresponding to peak envelope power of the audio modulated signal, if provided by the TV interface device, must not exceed $155 R^{1/2} \mu\text{V}$ for Cable Receiver system terminal device of TV interface device used with a master antenna, and $77.5 R^{1/2} \mu\text{V}$ for all other TV interface device. Losses in decibels in any impedance-matching network used were added to the measured value in dB μV . The EUT was configured in accordance with ANSI C63.4-2009 Section 12.2 as below configuration block diagram.

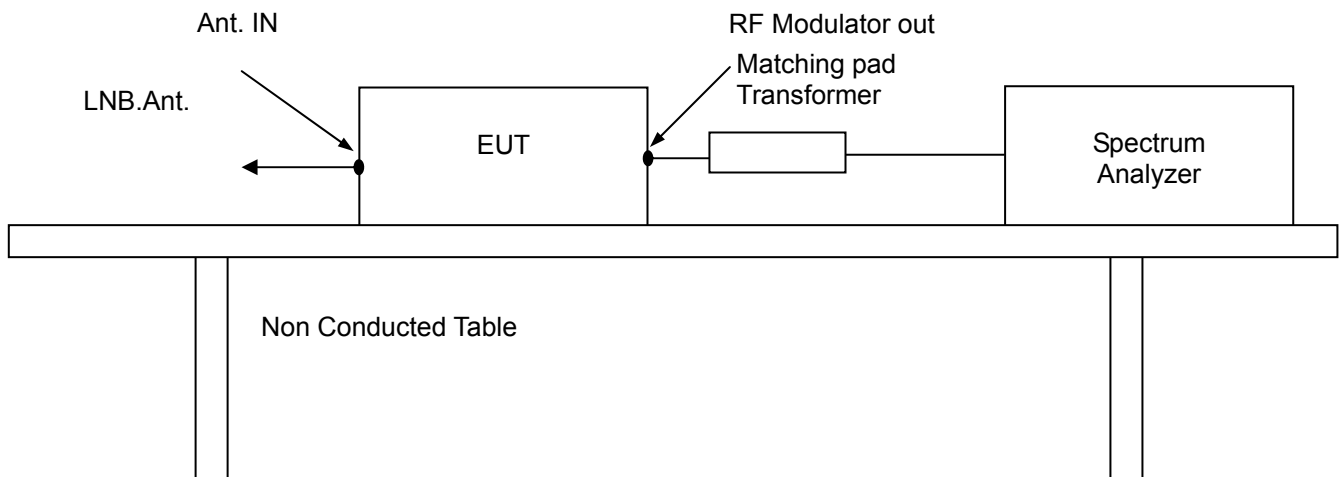

3.5 Output Terminal Conducted Spurious Emission Measurement

The RF output signal was fed to the TV receiver via coaxial Satellite Receiver. Measurements were made by direct connection to the spectrum analyzer and TV interface device with 50 ohm/75 ohm matching transformer. The frequency range 30 MHz to 1 000 MHz was investigated for significant emission.

The maximum RMS voltage of any emission appearing on frequencies removed by more than 4.6 MHz below and 7.4 MHz above the video carrier frequency on which the TV interface device is operated must not exceed $692.8 R^{1/2} \mu\text{V}$ for Cable Receiver system terminal device or TV interface device used with a master antenna and $10.95 R^{1/2} \mu\text{V}$ for all other TV interface device when terminated with a resistance (R ohms) matching the rated output impedance of the TV interface device. The EUT was configured in accordance with ANSI C63.4-2009 Section 12.2 as below configuration block diagram.

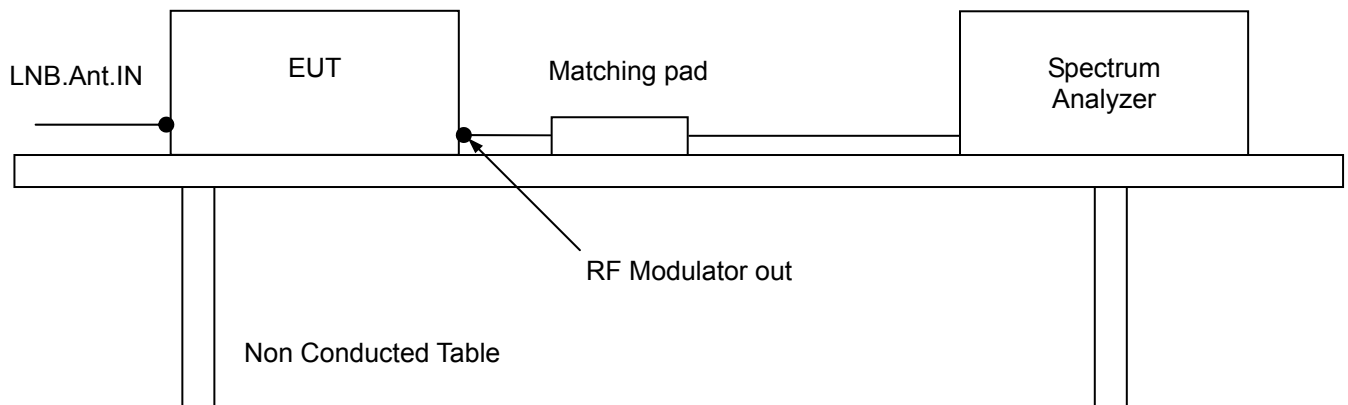

3.6 Antenna Transfer Switch Measurement

Isolation was measured for all positions of an antenna transfer switch on all output channels of the EUT. TV interface device transfer switch isolation is the difference the levels of a signal going into one antenna input port of the switch and that of the same signal coming out of another antenna terminal of transfer switch. The isolation of an antenna transfer switch equipped with coaxial connector performed by measuring the maximum voltage of the visual carrier. Measurements were made of the maximum RMS voltage at the antenna input terminals of the switch for all positions of the transfer switch. The maximum voltage corresponds to the peak envelope power of the video signal during maximum amplitude peaks. In either position of the receiver transfer switch, the maximum voltage at the receiving antenna input terminals of the switch when terminated with a resistance (R ohms) matching the rated impedance of the antenna input of the switch, must not exceed $0.346 R^{1/2} \mu V$.

The maximum voltage corresponds to the peak envelope power of the video modulated signal during maximum amplitude.

The EUT was configured in accordance with ANSI C63.4-2009 Section 12.2 as below configuration block diagram. And the EUT configuration can also be seen in Appendix B. Photographs of the test setup.

The unused RF input/output terminals are terminated in proper impedance. The antenna input terminal is connected to the input of preamplifier through the matching transformer coaxial Satellite Receiver. And the output of preamplifier is connected to the spectrum analyzer. Then, the signal level on the antenna input terminal is measured under the EUT condition produced the maximum signal level.

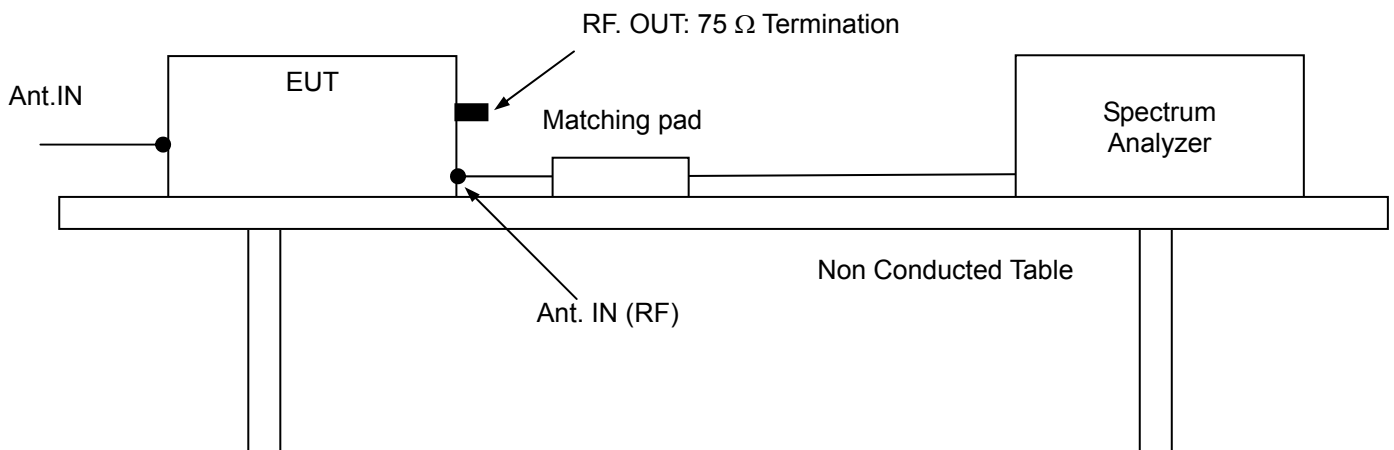

4. TEST CONDITION

4.1 Test Configuration

The device was configured for testing in a typical fashion (as a customer would normally use it). During the tests, the EUT and the supported equipments were installed to meet FCC requirement and operated in a manner which tends to maximize its emission level in a typical application.

4.2 EUT operation

The EUT was set to the normal receiving mode in a TV mode during all the testing in a manner similar to a typical use. For the EUT operation, the satellite live signal was fed to the EUT through the LNB input. During the preliminary testing, the worst case condition of the operating mode was ch.3

4.3 Support Equipment Used

| Description | Model Name | Serial No. | Manufacturer | FCC |
|-------------------------------|----------------|-----------------------|--------------------------------|-----|
| Adapter (for EUT) | EDF0500150A1BB | NONE | ChungKwang Tech Inc. | - |
| IR (for EUT) | NONE | NONE | NONE | - |
| Remote Control Unit (for EUT) | NONE | NONE | NONE | - |
| LED LCD TV | M2380DM | 203KCY Q 8V226 | LG Electronics | - |
| Adapter (for LED LCD TV) | PA-1650-68 | OC17N612314 032598 | Lite-On Technology Corporation | - |

4.4 Type of Cables Used

| Device from | Device to | Type of I/O port | Length[m] | Type of shield | Used ferrite core |
|-------------|------------|------------------|-----------|----------------|-------------------|
| EUT | LED LCD TV | HDMI | 1.5 | Shielded | X |
| EUT | LED LCD TV | TV OUT | > 3.0 | Shielded | X |
| EUT | IR | IR | 1.2 | Shielded | X |
| EUT | Cable ANT. | Cable Tuner | > 3.0 | Shielded | X |
| EUT | Adapter | DC Input | 1.2 | Shielded | X |
| LED LCD TV | Adapter | DC Input | 1.2 | Shielded | O |

4.5 The setup drawing(s)

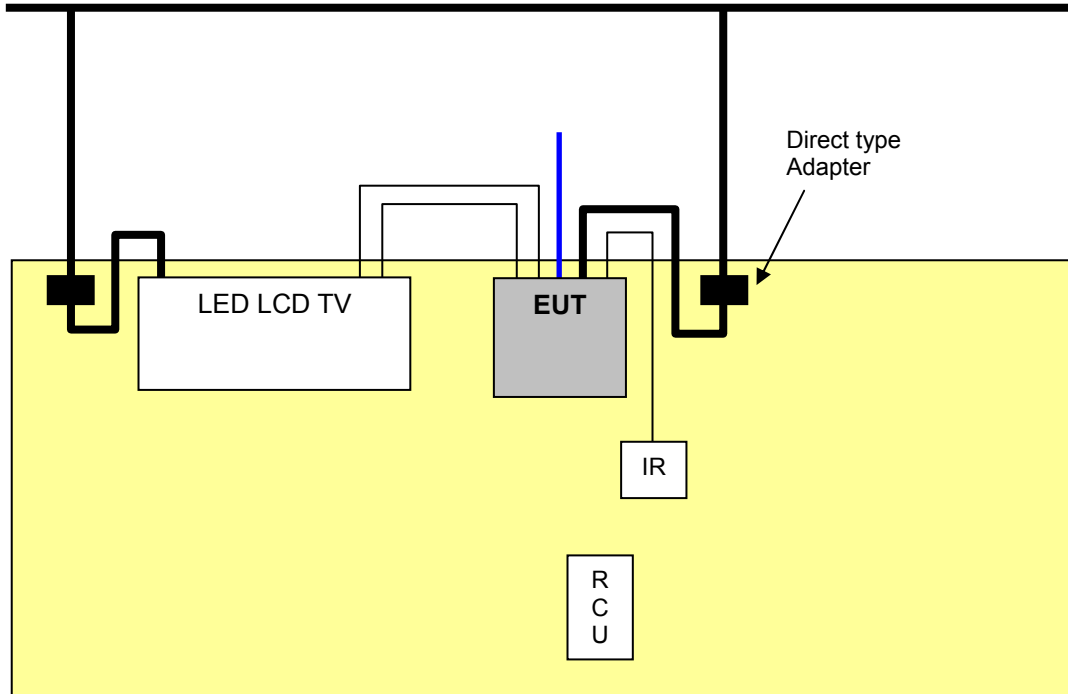

5. TEST RESULTS

5.1 Summary of Test Results

The measurement results were obtained with the EUT tested in the conditions described in this report. Detailed measurement data and plots showing the maximum emission of the EUT are reported.

| FCC Rule | Measurement Required | Result |
|------------------|---|--------------------|
| 15.107(a) | AC Power line Conducted Emission Measurement | Passed by 12.70 dB |
| 15.109(a) | Radiated Emission Measurement (Below 1 GHz) | Passed by 6.20 dB |
| 15.109(a) | Radiated Emission Measurement (Above 1 GHz) | Passed by 19.10 dB |
| 15.111(a) | Antenna Power Conduction Measurement | Passed by 9.10 dB |
| 15.115(b)(1)(i) | Output Signal Level Measurement | Passed by 3.33 dB |
| 15.115(b)(2)(ii) | Output Terminal Conducted Spurious Emission Measurement | Passed by 4.20 dB |
| 15.115(c)(1)(ii) | Antenna Transfer Switch Measurement | Passed * |

* During this test, no signal detected.

The data collected shows that the **Digital Multimedia Technology Co., Ltd. / SET-TOP BOX / DMS2444UHDS** complied with technical requirements of above rules part 15.107(a) and 15.109(a), 15.111 and 15.115(b),(c) Limits.

The equipment is not modified anything, mechanical or circuits to improve EMI status during a measurement. No EMI suppression device(s) was added and/or modified during testing.

5.2 AC Power line Conducted Emissions Measurement

5.2.1 AC Power line Conducted Emissions Data

| | |
|-----------------------|---|
| EUT | SET-TOP BOX / DMS2444UHDS (S/N: N/A) |
| Limit apply to | FCC Part 15 Subpart B Section 15.107(a) Class B |
| Test Date | June 01, 2016 |
| Environmental of Test | (20.5 ± 0.0) °C, (41 ± 0) % R.H., (101.4 ± 0.0) kPa |
| Operating Condition | TV Mode (Channel 3) |
| Result | Passed by 12.70 dB |

Conducted Emission Test Data

The following data and graph shows the highest levels of conducted emissions on both polarizations of hot and neutral line.

Detector mode: CISPR Quasi-Peak mode (6 dB Bandwidth: 9 kHz)

NOTES:

1. Please see the measured data and graph in next page.
2. The c.f value was included the LISN factor and cable loss.
3. Result value = Reading + c.f
4. Margin value = Limit - Result
5. Measurement were performed at the AC Power Inlet in the frequency band of 150 kHz ~ 30 MHz according to the FCC Part 15.107(a) Class B.
6. If the average limit is met when using a Quasi-peak detector receiver, the EUT shall be deemed to meet both limits and measurement with the average detector receiver is unnecessary.
7. Channel 3 was the worst case operation mode.

Line: HOT

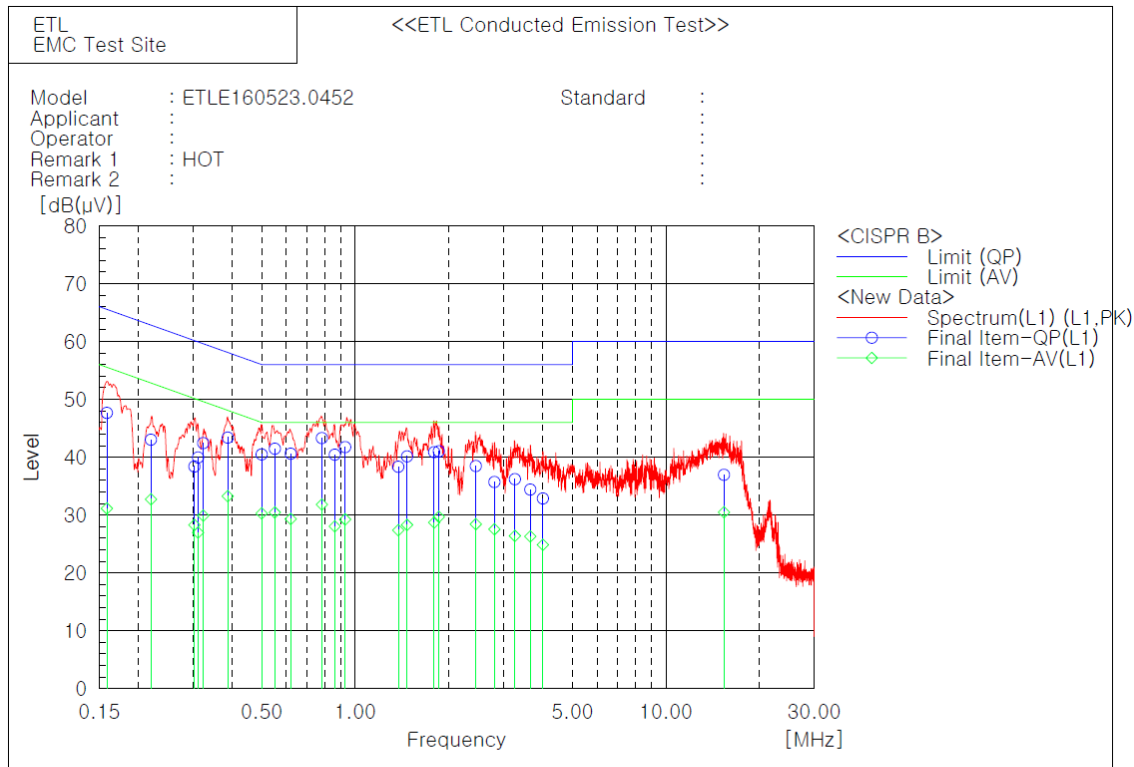

Final Result

--- L1 Phase ---

| No. | Frequency [MHz] | Reading QP [dB(μV)] | Reading AV [dB(μV)] | c. f [dB] | Result QP [dB(μV)] | Result AV [dB(μV)] | Limit QP [dB(μV)] | Limit AV [dB(μV)] | Margin QP [dB] | Margin AV [dB] |
|-----|-----------------|---------------------|---------------------|-----------|--------------------|--------------------|-------------------|-------------------|----------------|----------------|
| 1 | 0.15865 | 36.6 | 20.0 | 11.1 | 47.7 | 31.1 | 65.5 | 55.5 | 17.8 | 24.4 |
| 2 | 0.22004 | 32.4 | 22.1 | 10.6 | 43.0 | 32.7 | 62.8 | 52.8 | 19.8 | 20.1 |
| 3 | 0.30353 | 28.0 | 17.9 | 10.4 | 38.4 | 28.3 | 60.1 | 50.1 | 21.7 | 21.8 |
| 4 | 0.31182 | 29.6 | 16.6 | 10.4 | 40.0 | 27.0 | 59.9 | 49.9 | 19.9 | 22.9 |
| 5 | 0.32387 | 32.0 | 19.5 | 10.4 | 42.4 | 29.9 | 59.6 | 49.6 | 17.2 | 19.7 |
| 6 | 0.38859 | 33.1 | 23.0 | 10.3 | 43.4 | 33.3 | 58.1 | 48.1 | 14.7 | 14.8 |
| 7 | 0.49975 | 30.2 | 20.0 | 10.3 | 40.5 | 30.3 | 56.0 | 46.0 | 15.5 | 15.7 |
| 8 | 0.55095 | 31.2 | 20.1 | 10.3 | 41.5 | 30.4 | 56.0 | 46.0 | 14.5 | 15.6 |
| 9 | 0.62005 | 30.3 | 19.0 | 10.3 | 40.6 | 29.3 | 56.0 | 46.0 | 15.4 | 16.7 |
| 10 | 0.78085 | 33.0 | 21.5 | 10.3 | 43.3 | 31.8 | 56.0 | 46.0 | 12.7 | 14.2 |
| 11 | 0.85935 | 30.1 | 17.7 | 10.3 | 40.4 | 28.0 | 56.0 | 46.0 | 15.6 | 18.0 |
| 12 | 0.92815 | 31.5 | 19.0 | 10.2 | 41.7 | 29.2 | 56.0 | 46.0 | 14.3 | 16.8 |
| 13 | 1.3763 | 28.1 | 17.2 | 10.2 | 38.3 | 27.4 | 56.0 | 46.0 | 17.7 | 18.6 |
| 14 | 1.4679 | 29.9 | 18.1 | 10.2 | 40.1 | 28.3 | 56.0 | 46.0 | 15.9 | 17.7 |
| 15 | 1.79555 | 30.7 | 18.5 | 10.2 | 40.9 | 28.7 | 56.0 | 46.0 | 15.1 | 17.3 |
| 16 | 1.8579 | 30.8 | 19.5 | 10.2 | 41.0 | 29.7 | 56.0 | 46.0 | 15.0 | 16.3 |
| 17 | 2.44495 | 28.3 | 18.2 | 10.2 | 38.5 | 28.4 | 56.0 | 46.0 | 17.5 | 17.6 |
| 18 | 2.80345 | 25.5 | 17.3 | 10.2 | 35.7 | 27.5 | 56.0 | 46.0 | 20.3 | 18.5 |
| 19 | 3.2658 | 26.0 | 16.2 | 10.2 | 36.2 | 26.4 | 56.0 | 46.0 | 19.8 | 19.6 |
| 20 | 3.65862 | 24.2 | 16.1 | 10.2 | 34.4 | 26.3 | 56.0 | 46.0 | 21.6 | 19.7 |
| 21 | 4.0173 | 22.8 | 14.8 | 10.1 | 32.9 | 24.9 | 56.0 | 46.0 | 23.1 | 21.1 |
| 22 | 15.3664 | 26.7 | 20.2 | 10.3 | 37.0 | 30.5 | 60.0 | 50.0 | 23.0 | 19.5 |

Line: Neutral

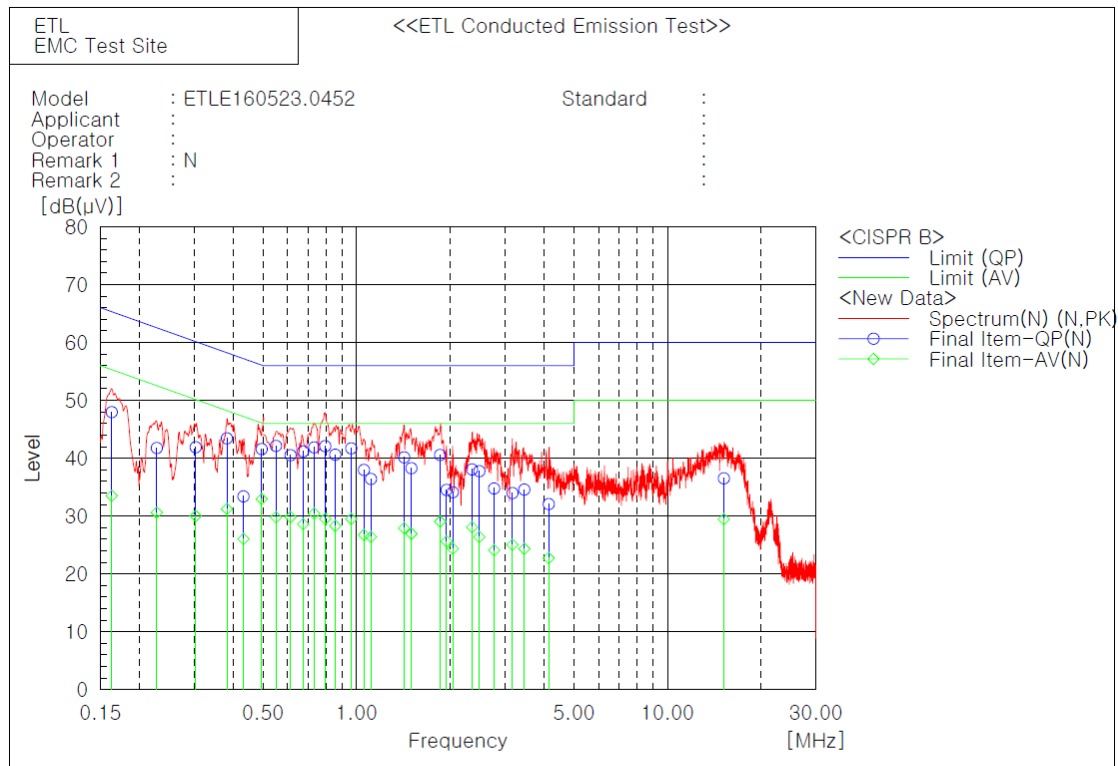

Final Result

| --- N Phase --- | | | | | | | | | | |
|-----------------|-----------|------------|------------|------|-----------|-----------|----------|----------|-----------|-----------|
| No. | Frequency | Reading QP | Reading AV | c. f | Result QP | Result AV | Limit QP | Limit AV | Margin QP | Margin AV |
| | [MHz] | [dB(µV)] | [dB(µV)] | [dB] | [dB(µV)] | [dB(µV)] | [dB(µV)] | [dB(µV)] | [dB] | [dB] |
| 1 | 0.1632 | 37.1 | 22.6 | 10.9 | 48.0 | 33.5 | 65.3 | 55.3 | 17.3 | 21.8 |
| 2 | 0.22781 | 31.3 | 20.1 | 10.5 | 41.8 | 30.6 | 62.5 | 52.5 | 20.7 | 21.9 |
| 3 | 0.30393 | 31.5 | 19.6 | 10.4 | 41.9 | 30.0 | 60.1 | 50.1 | 18.2 | 20.1 |
| 4 | 0.38275 | 33.1 | 20.9 | 10.3 | 43.4 | 31.2 | 58.2 | 48.2 | 14.8 | 17.0 |
| 5 | 0.43266 | 23.1 | 15.7 | 10.3 | 33.4 | 26.0 | 57.2 | 47.2 | 23.8 | 21.2 |
| 6 | 0.49524 | 31.3 | 22.6 | 10.3 | 41.6 | 32.9 | 56.1 | 46.1 | 14.5 | 13.2 |
| 7 | 0.55075 | 31.8 | 19.5 | 10.3 | 42.1 | 29.8 | 56.0 | 46.0 | 13.9 | 16.2 |
| 8 | 0.6132 | 30.2 | 19.5 | 10.3 | 40.5 | 29.8 | 56.0 | 46.0 | 15.5 | 16.2 |
| 9 | 0.6734 | 30.9 | 18.3 | 10.3 | 41.2 | 28.6 | 56.0 | 46.0 | 14.8 | 17.4 |
| 10 | 0.73065 | 31.6 | 20.1 | 10.3 | 41.9 | 30.4 | 56.0 | 46.0 | 14.1 | 15.6 |
| 11 | 0.7926 | 31.8 | 19.2 | 10.3 | 42.1 | 29.5 | 56.0 | 46.0 | 13.9 | 16.5 |
| 12 | 0.8537 | 30.3 | 18.0 | 10.3 | 40.6 | 28.3 | 56.0 | 46.0 | 15.4 | 17.7 |
| 13 | 0.9611 | 31.5 | 19.3 | 10.2 | 41.7 | 29.5 | 56.0 | 46.0 | 14.3 | 16.5 |
| 14 | 1.05595 | 27.8 | 16.5 | 10.2 | 38.0 | 26.7 | 56.0 | 46.0 | 18.0 | 19.3 |
| 15 | 1.1121 | 26.2 | 16.2 | 10.2 | 36.4 | 26.4 | 56.0 | 46.0 | 19.6 | 19.6 |
| 16 | 1.4221 | 29.9 | 17.7 | 10.2 | 40.1 | 27.9 | 56.0 | 46.0 | 15.9 | 18.1 |
| 17 | 1.50125 | 28.1 | 16.7 | 10.2 | 38.3 | 26.9 | 56.0 | 46.0 | 17.7 | 19.1 |
| 18 | 1.8564 | 30.4 | 18.8 | 10.2 | 40.6 | 29.0 | 56.0 | 46.0 | 15.4 | 17.0 |
| 19 | 1.94665 | 24.3 | 15.4 | 10.2 | 34.5 | 25.6 | 56.0 | 46.0 | 21.5 | 20.4 |
| 20 | 2.03925 | 23.9 | 14.2 | 10.2 | 34.1 | 24.4 | 56.0 | 46.0 | 21.9 | 21.6 |
| 21 | 2.35155 | 27.9 | 17.9 | 10.2 | 38.1 | 28.1 | 56.0 | 46.0 | 17.9 | 17.9 |
| 22 | 2.4813 | 27.6 | 16.2 | 10.2 | 37.8 | 26.4 | 56.0 | 46.0 | 18.2 | 19.6 |
| 23 | 2.7698 | 24.6 | 13.9 | 10.2 | 34.8 | 24.1 | 56.0 | 46.0 | 21.2 | 21.9 |
| 24 | 3.17316 | 23.8 | 14.8 | 10.2 | 34.0 | 25.0 | 56.0 | 46.0 | 22.0 | 21.0 |
| 25 | 3.46344 | 24.4 | 14.1 | 10.2 | 34.6 | 24.3 | 56.0 | 46.0 | 21.4 | 21.7 |
| 26 | 4.15062 | 22.0 | 12.6 | 10.1 | 32.1 | 22.7 | 56.0 | 46.0 | 23.9 | 23.3 |
| 27 | 15.1828 | 26.0 | 19.0 | 10.5 | 36.5 | 29.5 | 60.0 | 50.0 | 23.5 | 20.5 |

5.3 Radiated Emissions Measurement

5.3.1 Radiated Emissions Data

- Below 1 GHz

| | |
|-----------------------|---|
| EUT | SET-TOP BOX / DMS2444UHDS (S/N: N/A) |
| Limit apply to | FCC Part 15 Subpart B Section 15.109(a) Class B |
| Test Date | May 31, 2016 |
| Environmental of Test | (27.2 ± 0.4) °C, (62 ± 2) % R.H., (100.5 ± 0.0) kPa |
| Operating Condition | TV Mode (Channel 3) |
| Result | Passed by 6.20 dB |

Radiated Emission Test Data

The following table shows the highest levels of radiated emissions on both polarizations of horizontal and vertical.
 Detector mode: CISPR Quasi-Peak mode (6 dB Bandwidth: 120 kHz)

| Frequency [MHz] | Reading [dB(μV)] | Polarization (*H/**V) | Ant. Factor [dB/m] | Cable Loss [dB(μV)] | Height [cm] | Result [dB(μV/m)] | Limit [dB(μV/m)] | Margin [dB] |
|-----------------|------------------|-----------------------|--------------------|---------------------|-------------|-------------------|------------------|-------------|
| 38.46 | 45.10 | V | 12.59 | -30.91 | 100 | 26.78 | 40.00 | 13.22 |
| 48.27 | 51.40 | V | 13.20 | -30.80 | 100 | 33.80 | 40.00 | 6.20 |

NOTES:

1. * H : Horizontal polarization , ** V : Vertical polarization
2. The cable loss value was included the Amp. Gain.
3. Result = Reading + Antenna factor + Cable loss
4. Margin value = Limit - Result
5. The measurement was performed for the frequency range 30 MHz ~ 1 000 MHz according to the FCC Part 15.109(a) Class B.
6. Channel 3 was the worst case operation mode.

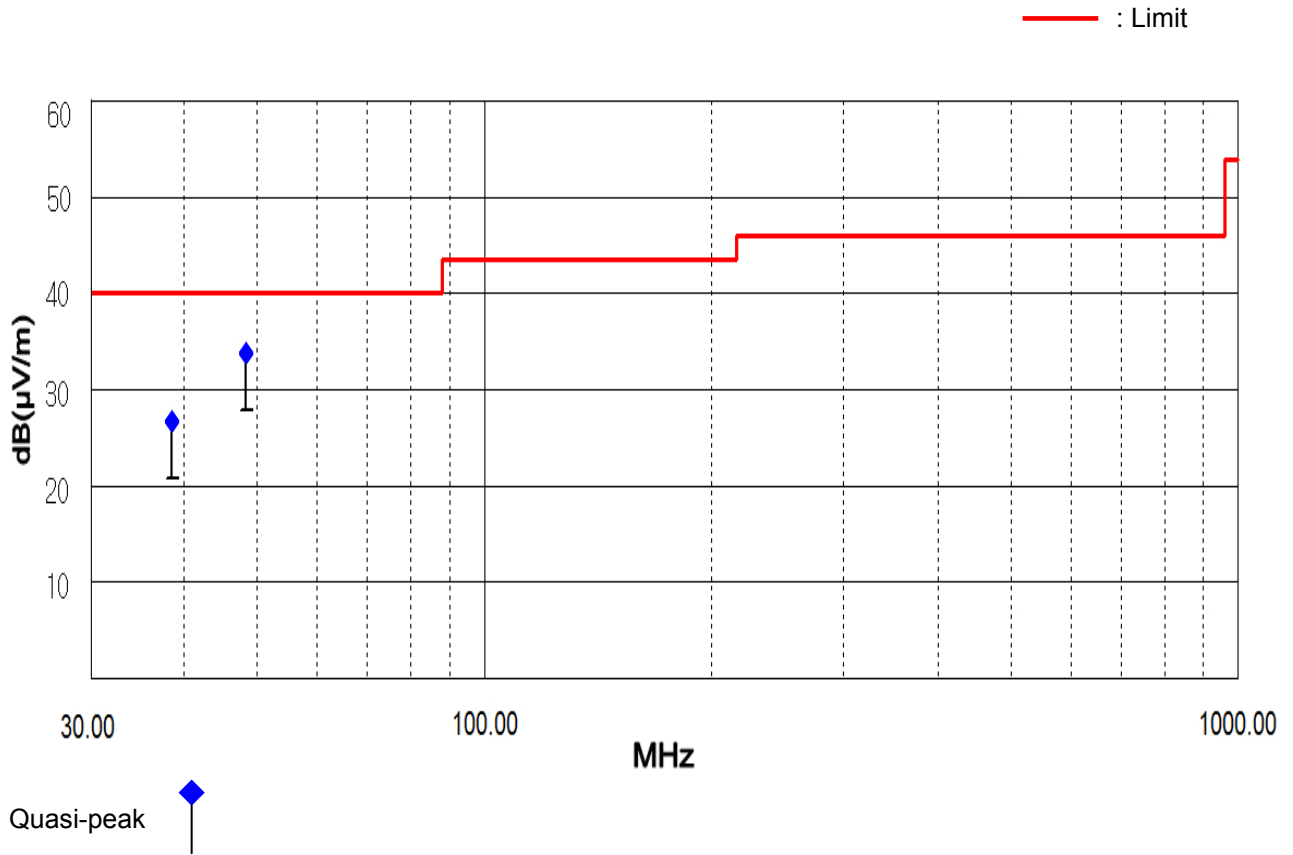

- Above 1 GHz

| | |
|-----------------------|---|
| EUT | SET-TOP BOX / DMS2444UHDS (S/N: N/A) |
| Limit apply to | FCC Part 15 Subpart B Section 15.109(a) Class B |
| Test Date | June 02, 2016 |
| Environmental of Test | (21.5 ± 0.0) °C, (42 ± 0) % R.H., (101.2 ± 0.0) kPa |
| Operating Condition | TV Mode (Channel 3) |
| Result | Passed by 19.10 dB |

Radiated Emission Test Data

The following data and graph shows the highest levels of radiated emissions on both polarizations of horizontal and vertical.

Detector mode: CISPR Peak mode, Average mode

NOTES:

1. Please see the measured data and graph in next page.
2. H : Horizontal polarization , V : Vertical polarization
3. The c.f value was included the antenna factor, cable loss and Amp. Gain.
4. Result value = Reading + c.f
5. Margin value = Limit - Result
6. The measurement was performed for the frequency range 1 GHz ~ 6 GHz according to FCC Part 15.109(a) Class B.
7. Upper frequency of measurement range: 5th harmonic of the highest frequency.
8. Channel 3 was the worst case operation mode.

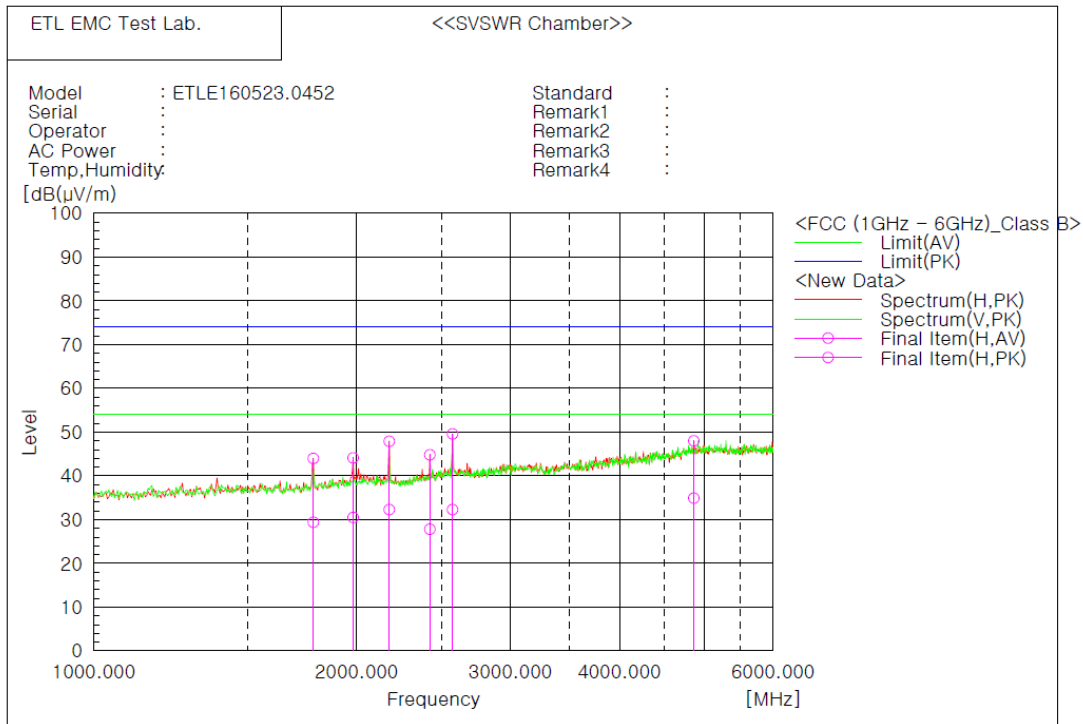

Final Result

| — Horizontal Polarization (AV)— | | | | | | |
|---------------------------------|-----------------|------------------|---------------|-------------------|------------------|-------------|
| No. | Frequency [MHz] | Reading [dB(μV)] | c.f [dB(1/m)] | Result [dB(μV/m)] | Limit [dB(μV/m)] | Margin [dB] |
| 1 | 1783.760 | 41.9 | -12.5 | 29.4 | 54.0 | 24.6 |
| 2 | 1981.720 | 42.3 | -11.8 | 30.5 | 54.0 | 23.5 |
| 3 | 2179.680 | 43.2 | -10.9 | 32.3 | 54.0 | 21.7 |
| 4 | 2426.120 | 37.5 | -9.7 | 27.8 | 54.0 | 26.2 |
| 5 | 2575.600 | 41.2 | -8.9 | 32.3 | 54.0 | 21.7 |
| 6 | 4866.480 | 36.3 | -1.4 | 34.9 | 54.0 | 19.1 |

| — Horizontal Polarization (PK)— | | | | | | |
|---------------------------------|-----------------|------------------|---------------|-------------------|------------------|-------------|
| No. | Frequency [MHz] | Reading [dB(μV)] | c.f [dB(1/m)] | Result [dB(μV/m)] | Limit [dB(μV/m)] | Margin [dB] |
| 1 | 1783.760 | 56.5 | -12.5 | 44.0 | 74.0 | 30.0 |
| 2 | 1981.720 | 55.9 | -11.8 | 44.1 | 74.0 | 29.9 |
| 3 | 2179.680 | 58.8 | -10.9 | 47.9 | 74.0 | 26.1 |
| 4 | 2426.120 | 54.5 | -9.7 | 44.8 | 74.0 | 29.2 |
| 5 | 2575.600 | 58.5 | -8.9 | 49.6 | 74.0 | 24.4 |
| 6 | 4866.480 | 49.4 | -1.4 | 48.0 | 74.0 | 26.0 |

5.4 Antenna Power Conduction Measurement

5.4.1 Antenna Power Conduction Measurement

| | |
|-----------------------|---|
| EUT | SET-TOP BOX / DMS2444UHDS (S/N: N/A) |
| Limit apply to | FCC Part 15 Subpart B Section 15.111(a) |
| Test Date | June 07, 2016 |
| Environmental of Test | (20.6 ± 0.0) °C, (37 ± 0) % R.H., (100.9 ± 0.0) kPa |
| Operating Condition | Signal tuning mode |
| Result | Passed by 9.10 dB |

Antenna Power Conduction Test Data

| Test port | Tuned Frequency [MHz] | Meter Reading [dB(μV)] | Correction Factor [dB] | Result [dB(μV)] | Limit [dB(μV)] | Margin [dB] |
|-----------|-----------------------|------------------------|------------------------|-----------------|----------------|-------------|
| CABLE IN | 118.020 | 6.70 | 23.90 | 30.60 | 50.00 | 19.40 |
| | 244.380 | 6.70 | 24.20 | 30.90 | 50.00 | 19.10 |
| | 494.600 | 5.40 | 24.40 | 29.80 | 50.00 | 20.20 |
| | 820.800 | 7.10 | 24.20 | 31.30 | 50.00 | 18.70 |
| | 1 121.900 | 15.50 | 24.60 | 40.10 | 50.00 | 9.90 |
| | 2 016.600 | 16.00 | 24.90 | 40.90 | 50.00 | 9.10 |

NOTES:

1. **Result = Meter Reading + Correction Factor (Matching Loss + Cable loss)**
2. **Margin value = Limit - Result**
3. **Measurements using the CISPR Quasi-peak mode in the frequency range 30 MHz to 6 GHz and measurements using the CISPR peak mode in the frequency range above 1 GHz.**
4. **The limits is 2.0 μW in the frequency range section 15.33(b)(1) of FCC Part 15.**

5.5 Output Signal Level Measurement

5.5.1 Output Signal Level Measurement

| | |
|-----------------------|---|
| EUT | SET-TOP BOX / DMS2444UHDS (S/N: N/A) |
| Limit apply to | FCC Part15 Subpart B Section 15.115(b)(1)(i) |
| Test Date | June 07, 2016 |
| Environmental of Test | (20.7 ± 0.0) °C, (37 ± 0) % R.H., (100.9 ± 0.0) kPa |
| Operating Condition | TV Mode (Channel 3, Channel 4) |
| Result | Passed by 3.33 dB |

Output Signal Level Test Data

| Test Channel | Emission Frequency [MHz] | Meter Reading [dB(μV)] | Correction Factor [dB] | Signal Level [dB(μV)] | Limit [dB(μV)] | Margin [dB] |
|--------------|--------------------------|------------------------|------------------------|-----------------------|----------------|-------------|
| 3 | 61.250 | 64.57 | 7.60 | 72.17 | 75.50 | 3.33 |
| | 65.750 | 49.92 | 7.60 | 57.52 | 62.50 | 4.98 |
| 4 | 67.250 | 64.54 | 7.60 | 72.14 | 75.50 | 3.36 |
| | 71.750 | 49.82 | 7.60 | 57.42 | 62.50 | 5.08 |

NOTES:

1. The correction factor consist of the insertion loss of the impedance matching transformer and the coaxial Satellite Receiver used for the test.
2. The spectrum was checked in each test mode and operation mode, and the maximum measured data were reported.
3. Signal Level = Meter Reading + Correction Factor (Matching Loss + Cable loss)
4. Margin value = Limit - Signal Level

5.6 Output Terminal Conducted Spurious Emission Measurement

5.6.1 Output Terminal Conducted Spurious Emission Measurement

| | |
|-----------------------|---|
| EUT | SET-TOP BOX / DMS2444UHDS (S/N: N/A) |
| Limit apply to | FCC Part15 Subpart B Section 15.115(b)(2)(i) |
| Test Date | June 07, 2016 |
| Environmental of Test | (20.8 ± 0.0) °C, (37 ± 0) % R.H., (100.9 ± 0.0) kPa |
| Operating Condition | TV Mode (Channel 3, Channel 4) |
| Result | Passed by 4.20 dB |

Output Terminal Conducted Spurious Test Data

| Test Channel | Emission Frequency [MHz] | Meter Reading [dB(μV)] | Correction Factor [dB] | Result [dB(μV)] | Limit [dB(μV)] | Margin [dB] |
|--------------|--------------------------|------------------------|------------------------|-----------------|----------------|-------------|
| 3 | 56.460 | 49.90 | 7.60 | 57.50 | 75.50 | 18.00 |
| | 61.320 | 63.70 | 7.60 | 71.30 | 75.50 | 4.20 |
| | 65.640 | 49.90 | 7.60 | 57.50 | 75.50 | 18.00 |
| | 108.300 | 14.00 | 7.60 | 21.60 | 75.50 | 53.90 |
| | 122.340 | 19.30 | 7.70 | 27.00 | 75.50 | 48.50 |
| | 179.580 | 20.10 | 7.70 | 27.80 | 75.50 | 47.70 |
| | 183.900 | 30.60 | 7.70 | 38.30 | 75.50 | 37.20 |
| | 188.220 | 19.00 | 7.70 | 26.70 | 75.50 | 48.80 |
| | 980.400 | 28.40 | 8.00 | 36.40 | 75.50 | 39.10 |

NOTES:

1. The correction factor consists of the insertion loss of the impedance matching transformer.
2. The spectrum was checked in each test mode and operation mode, and the maximum measured data were reported.
3. Result = Meter Reading + Correction (Matching Loss+ Cable loss)
4. Margin value = Limit - Signal Level

| Test Channel | Emission Frequency [MHz] | Meter Reading [dB(μV)] | Correction Factor [dB] | Result [dB(μV)] | Limit [dB(μV)] | Margin [dB] |
|--------------|--------------------------|------------------------|------------------------|-----------------|----------------|-------------|
| 4 | 62.400 | 50.10 | 7.60 | 57.70 | 75.50 | 17.80 |
| | 67.260 | 63.70 | 7.60 | 71.30 | 75.50 | 4.20 |
| | 71.580 | 49.70 | 7.60 | 57.30 | 75.50 | 18.20 |
| | 107.760 | 11.60 | 7.60 | 19.20 | 75.50 | 56.30 |
| | 134.220 | 16.00 | 7.70 | 23.70 | 75.50 | 51.80 |
| | 197.400 | 17.50 | 7.70 | 25.20 | 75.50 | 50.30 |
| | 201.720 | 29.50 | 7.70 | 37.20 | 75.50 | 38.30 |
| | 206.580 | 15.40 | 7.70 | 23.10 | 75.50 | 52.40 |

NOTES:

1. The correction factor consists of the insertion loss of the impedance matching transformer.
2. The spectrum was checked in each test mode and operation mode, and the maximum measured data were reported.
3. Result = Meter Reading + Correction (Matching Loss+ Cable loss)
4. Margin value = Limit - Signal Level

5.7 Antenna Transfer Switch Measurement

5.7.1 Antenna Transfer Switch Measurement

| | |
|-----------------------|---|
| EUT | SET-TOP BOX / DMS2444UHDS (S/N: N/A) |
| Limit apply to | FCC Part15 Subpart B Section 15.115(c)(1)(ii) |
| Test Date | June 07, 2016 |
| Environmental of Test | (20.9 ± 0.0) °C, (37 ± 0) % R.H., (100.9 ± 0.0) kPa |
| Operating Condition | TV Mode (Channel 3, Channel 4) |
| Result | Passed |

Antenna Transfer Switch Test Data

| Test Channel | Emission Frequency [MHz] | Meter Reading [dB(μV)] | Correction Factor [dB] | Result [dB(μV)] | Limit [dB(μV)] | Margin [dB] |
|--------------|--------------------------|---|------------------------|-----------------|----------------|-------------|
| 3 | 61.250 | During this test, no signal detected | | | | - |
| 4 | 67.250 | | | | | - |

NOTES:

1. No emission was observed during the test. The spectrum was checked in each test mode and operation mode Transfer switch isolation measurements were made on the Channel 3 or 4 video output frequency of 61.25 MHz or 67.25 MHz and both positions of the transfer switch were checked for compliance.
2. To clarify the emissions emanated from ANT. input terminal on the EUT, RF pre-amplifier was used. The gain of pre-amplifier at each frequency measured from the EUT was obtained after sufficient warm-up for stabilization of gain. The correction factor consists of the insertion loss of the impedance matching transformer, the coaxial Satellite Receiver used for the test and the gain of pre-amplifier.
3. Result = Meter Reading + Correction Factor (Matching Loss + Cable loss)
4. Margin value = Limit - Result
5. Spectrum analyzer setting: Frequency Span 1 MHz, Resolution bandwidth 100 kHz, Video bandwidth 300 kHz, Detector function Peak mode.

6. SAMPLE CALCULATION

Sample Field Strength Calculation

The field strength is calculated by adding the Antenna Factor and Cable Factor.
The basic equation with a sample calculation is as follows:

$$FS = RA + AF + CF$$

Where FS = Field Strength

RA = Receiver Amplitude

AF = Antenna Factor

CF = Cable Attenuation Factor - Preamplifier Factor

$$dB(\mu V) = 20 \log_{10} (\mu V) : \text{Equation}$$

$$dB(\mu V) = dBm + 107$$

Example : @ 48.27 MHz

$$\text{Class B Limit} = 40.00 \text{ dB}(\mu V/m)$$

$$\text{Reading} = 51.40 \text{ dB}(\mu V)$$

$$\text{Antenna Factor} + (\text{Cable Loss} - \text{Amp. Gain.}) = 13.20 + (-30.80) = -17.60 \text{ dB}(\mu V/m)$$

$$\text{Total} = 33.80 \text{ dB}(\mu V/m)$$

$$\text{Margin} = 40.00 - 33.80 = 6.20 \text{ dB}$$

$$= 6.20 \text{ dB below Limit}$$

7. List of test equipments used for measurements

| | Test Equipment | Model | Mfg. | Serial No. | Cal. Date | Cal. Due Date |
|-------------------------------------|-------------------------|-------------|--------------------|------------|-----------|---------------|
| <input checked="" type="checkbox"/> | EMI Test Receiver | ESCS30 | R&S | 100087 | 16.01.12 | 17.01.12 |
| <input checked="" type="checkbox"/> | EMI Test Receiver | ESPI3 | R&S | 100478 | 15.09.03 | 16.09.03 |
| <input checked="" type="checkbox"/> | EMI Test Receiver | ESCS30 | R&S | 847793/005 | 16.03.14 | 17.03.14 |
| <input checked="" type="checkbox"/> | EMI Test Receiver | ESCI7 | R&S | 100851 | 15.09.04 | 16.09.04 |
| <input checked="" type="checkbox"/> | Amplifier | 310N | Sonoma Instrument | 284750 | 15.12.08 | 16.12.08 |
| <input checked="" type="checkbox"/> | Two-Line V-Network | ENV216 | R&S | 958599/106 | 16.03.15 | 17.03.15 |
| <input checked="" type="checkbox"/> | LISN | 3816-2 | EMCO | 1002 | 16.03.15 | 17.03.15 |
| <input checked="" type="checkbox"/> | Horn Antenna | BBHA 9120D | Schwarzbeck | 826 | 16.03.23 | 18.03.23 |
| <input checked="" type="checkbox"/> | Amplifier | TK-PA18 | TESTEK. | 120020 | 15.09.03 | 16.09.03 |
| <input checked="" type="checkbox"/> | LogBicon Antenna | VULB9160 | Schwarzbeck | 3164 | 15.06.08 | 17.06.08 |
| <input checked="" type="checkbox"/> | Matching Pad (RAM) | 358.5414.02 | R&S | 101841 | 15.09.04 | 16.09.04 |
| <input checked="" type="checkbox"/> | 75 Ω Directional Bridge | 86207A | Agilent | 3140A00678 | 15.09.04 | 16.09.04 |
| <input checked="" type="checkbox"/> | Turn-Table | DS1200-S | Innco Systems GmbH | 2740311 | N/A | N/A |
| <input checked="" type="checkbox"/> | Turn-Table | TT 1.35 SI | SES | - | N/A | N/A |
| <input checked="" type="checkbox"/> | Antenna Master | AM 4.5 | SES | - | N/A | N/A |