



**Test Report:** 1W04436

**Applicant:** Sur-Gard Security Systems  
3301 Langstaff Road  
Vaughan, Ontario  
L4K 4L2

**Equipment Under Test: (EUT)** SKYROUTE Cellemetry Transceiver

**FCC ID:** PED-SKYROUTE1

**In Accordance With:** **FCC Part 22**

**Tested By:** Nemko Canada Inc.  
3325 River Road, R.R. 5  
Ottawa, Ontario K1V 1H2

**Authorized By:**

G. Westwell, Wireless Technologist

**Date:** January 4, 2002

**Total Number of Pages:** 13

**Authorized Copy:** Soft Copy

*EQUIPMENT: SKYROUTE Cellemetry Transceiver*  
*FCC ID: PED-SKYROUTE1*

---

## **Table of Contents**

<b>Section 1. Summary of Test Results.....</b>	<b>3</b>
<b>Section 2. General Equipment Specification .....</b>	<b>5</b>
<b>Section 3. RF Power Output.....</b>	<b>8</b>
<b>Section 4. Field Strength of Spurious Emissions .....</b>	<b>9</b>
<b>Section 5. Block Diagrams.....</b>	<b>12</b>
<b>Section 6. Test Equipment List .....</b>	<b>13</b>

*EQUIPMENT: SKYROUTE Cellemetry Transceiver*  
*FCC ID: PED-SKYROUTE1*

---

## Section 1. Summary of Test Results

### General

**All measurements are traceable to national standards.**

These tests were conducted on a sample of the equipment for the purpose of demonstrating compliance with FCC Part 22.

THIS TEST REPORT RELATES ONLY TO THE ITEM(S) TESTED.

THE FOLLOWING DEVIATIONS FROM, ADDITIONS TO, OR EXCLUSIONS FROM THE TEST SPECIFICATIONS HAVE BEEN MADE.

See " Summary of Test Data".



TESTED BY:

Russell Grant, Wireless Group Manager

DATE: January 4, 2002

Nemko Canada Inc., a testing laboratory, is accredited by the Standards Council of Canada. The tests included in this report are within the scope of this accreditation. The results apply only to the samples tested.

Nemko Canada Inc. authorizes the above named company to reproduce this report provided it is reproduced in its entirety and for use by the company's employees only.

Any use which a third party makes of this report, or any reliance on or decisions to be made based on it, are the responsibility of such third parties. Nemko Canada Inc. accepts no responsibility for damages, if any, suffered by any third party as a result of decisions made or actions based on this report.

This report applies only to the items tested.

*EQUIPMENT: SKYROUTE Cellemetry Transceiver*  
*FCC ID: PED-SKYROUTE1*

---

**Summary Of Test Data**

<b>Name Of Test</b>	<b>Para. No.</b>	<b>Result</b>
RF Power Output	2.1046	Complies
Audio Frequency Response	2.1047	N/A
Audio Low-Pass Filter Response	2.1047	N/A
Modulation Limiting	2.1047	Not Tested
Occupied Bandwidth	2.1049	Not Tested
Spurious Emissions at Antenna Terminals	2.1051	Not Tested
Field Strength of Spurious Emissions	2.1053	Complies
Frequency Stability	2.1055	Not Tested
Transient Frequency Behavior	—	N/A

**Footnotes For N/A's:**

This equipment does not use voice modulation.

This equipment has been previously approved for user under FCC ID: APV09001. The approval is for OEM integration using 2.5 dBi antenna. The applicant has changed the antenna to 3 dBi and has mounted the transceiver module on a digital interface card for installation in an alarm control panel. Therefore measurements made were Transmitter Power Output and Transmitter Radiated Spurious Emissions. The applicant has permission from the original certificate holder to obtain equipment authorization based on the original certificate.

**Indoor**                      Temperature: 22 °C  
   Humidity: 52 %

**Outdoor**                     Temperature: 25 °C  
   Humidity: 54 %

*EQUIPMENT: SKYROUTE Cellemetry Transceiver*  
*FCC ID: PED-SKYROUTE1*

---

## Section 2. General Equipment Specification

**Model No.:** SKYROUTE, SKYROUTE MAX & SKYROUTE UT

**Serial No.:** None

**Date Received In Laboratory:** October 24, 2001

**Nemko Identification No.:** Item #34

Tx: 824 – 849 MHz

Rx: 826 – 894 MHz

3 Watts

36K0F1D

### Block Diagram

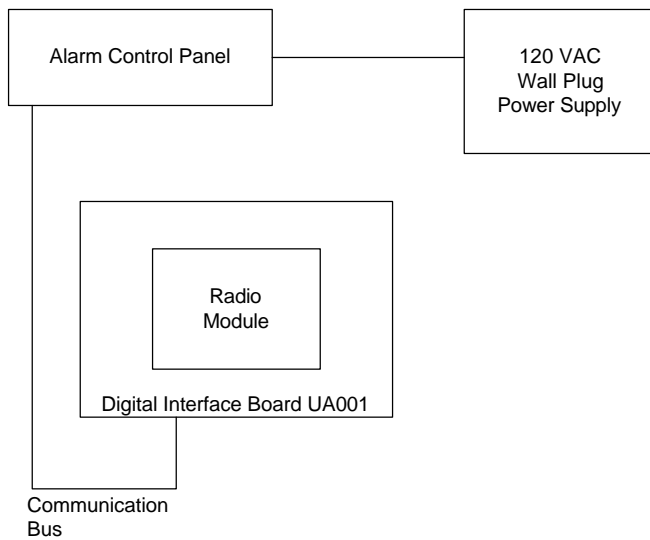

*EQUIPMENT: SKYROUTE Cellemetry Transceiver**FCC ID: PED-SKYROUTE1*

**MPE Statement**  
**FCC Radio Frequency Exposure Limits 1.1310**  
**Health Canada Safety Code 6**  
**Industry Canada RSS 102**

$$\text{General Population Limit} = f/1500 \text{ mW/cm}^2 = 824/1500 = 0.549 \text{ mW/cm}^2$$

$$\text{Therefore } \frac{GP}{4pR^2} \text{ } \mathbf{\$} \text{ Limit}$$

$$R \cong \sqrt{\frac{GP}{4pL}} = \sqrt{\frac{2 \times 3000}{4p0.549}} = 29.5 \text{ cm} \gg 30 \text{ cm}$$

$$\text{Measured} = 0.552 \text{ mW/cm}^2 @ 30 \text{ cm}$$

$$\text{Calculated Power Density} = \frac{2 \times 3000}{4p30^2} = 0.531 \text{ mW/cm}^2$$

The measured power density is within 0.2 dB of the calculated power density at 30 cm.

The first page of the installation manual contains an RF exposure warning statement.

Page ii cautions against the use of any antenna except that which is provided by the manufacturer.

Measurements were made using a Narda Microwave Radiation Monitor

*EQUIPMENT: SKYROUTE Cellemetry Transceiver*  
*FCC ID: PED-SKYROUTE1*

---

**Equipment Setup Photograph**

**Front View:**



*EQUIPMENT: SKYROUTE Cellemetry Transceiver*  
*FCC ID: PED-SKYROUTE1*

---

**Section 3. RF Power Output**

**Para. No.: 2.1046**

<b>Test Performed By:</b> Russell Grant	<b>Date of Test:</b> December 20, 2001
---	--

**Minimum Standard:** 22.913(a), 500 Watts ERP

**Test Results:** Complies within  $\pm 1$  dB of rated power.

**Measurement Data:** Measured: 35.7 dBm  
Rated: 34.8 dBm  
  
Antenna Gain: 3 dBi, 0.9 dBd  
ERP:  $35.7 + 0.9 = 36.6$  dBm



*EQUIPMENT: SKYROUTE Cellemetry Transceiver*  
*FCC ID: PED-SKYROUTE1*

---

**Section 4. Field Strength of Spurious Emissions**

**Para. No.: 2.1053**

<b>Test Performed By:</b> Russell Grant	<b>Date of Test:</b> December 20, 2001
---	--

**Minimum Standard:** 22.917 (d)(e), -13 dBm ERP

**Test Results:** Complies.

**Measurement Data:** See attached test data.

The spectrum was searched up to the 10<sup>th</sup> harmonic of the fundamental frequency of operation.

EQUIPMENT: SKYROUTE Cellemetry Transceiver  
FCC ID: PED-SKYROUTE1

**Test Data - Field Strength of Spurious Emissions**

Test Distance (meters) : 3	Range: A Tower		Receiver: Spectrum Analyzer		RBW(kHz) : 1000	Detector: Peak	
	Freq. (MHz)	Ant. *	Pol. (V/H)	RCVD Signal (dBµV/m)	Conversion Factor (dBµV, dBm)	Field Strength (dBm)	Limit (dBm)
1672.4	SSV	V	103.7	-117.5	-13.8	-13.0	0.8
1672.4	SSH	H	99.2	-117.9	-18.7	-13.0	5.7
2508.6	SSV	V	72.3	-123.2	-50.9	-13.0	37.9
2508.6	SSH	H	80.5	-122.9	-42.4	-13.0	29.4
3344.8	SSV	V	74.8	-119.9	-45.1	-13.0	32.1
3344.8	SSH	H	72.0	-120.8	-48.8	-13.0	35.8
4180.9	SSV	V	56.2	-113.4	-57.2	-13.0	44.2
4180.9	SSH	H	61.0	-113.1	-52.1	-13.0	39.1
5017.1	SSV	V	44.7	-111.8	-67.1	-13.0	54.1
5017.1	SSH	H	52.3	-110.9	-58.6	-13.0	45.6
5853.2	SSV	V	49.3	-110.2	-60.9	-13.0	47.9
5853.2	SSH	H	47.2	-107.7	-60.5	-13.0	47.5
6689.5	SSV	V	50.8	-109.4	-58.6	-13.0	45.6
6689.5	SSH	H	41.0	-107.2	-66.2	-13.0	53.2

**Notes:**  
 B/C = Biconical, B/L = Biconilog, L/P = Log-Periodic, H = Horn, D/P = Dipole  
 \* Re-measured using dipole antenna.  
 \*\* Includes cable loss when amplifier is not used.  
 \*\*\* Includes cable loss.  
 ( ) Denotes failing emission level.  
 N.D. = Not Detected

*EQUIPMENT: SKYROUTE Cellemetry Transceiver*  
*FCC ID: PED-SKYROUTE1*

---

**Field Strength of Spurious Emissions Photograph**

**Front View:**

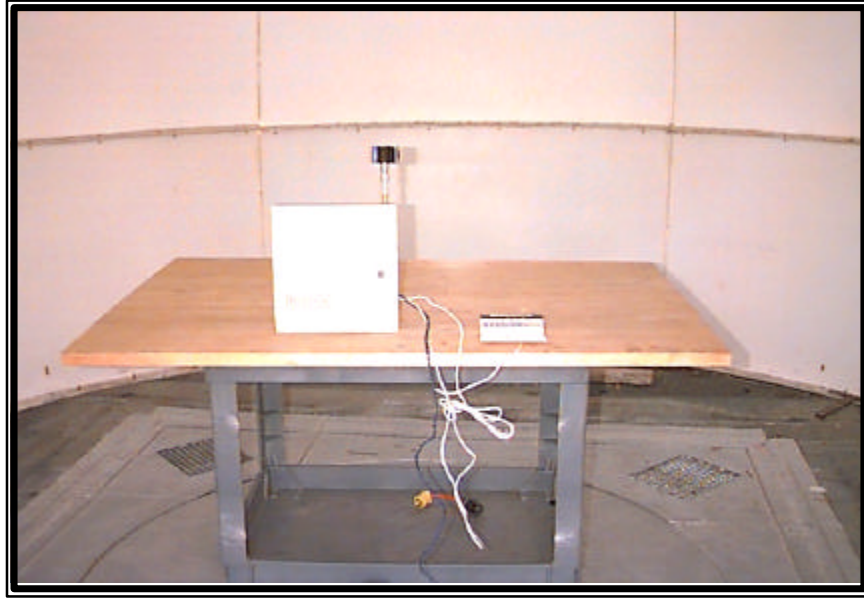

*EQUIPMENT: SKYROUTE Cellemetry Transceiver*  
*FCC ID: PED-SKYROUTE1*

---

## Section 5. Block Diagrams

### Para. No. 2.1046 - R.F. Power Output

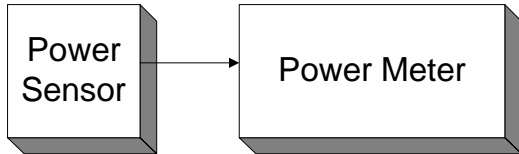

### Para. No. 2.1053 - Field Strength of Spurious Radiation

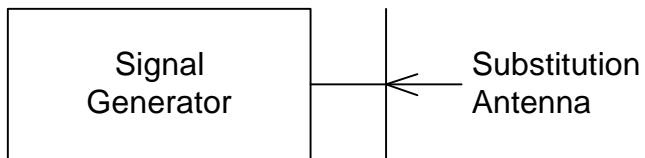
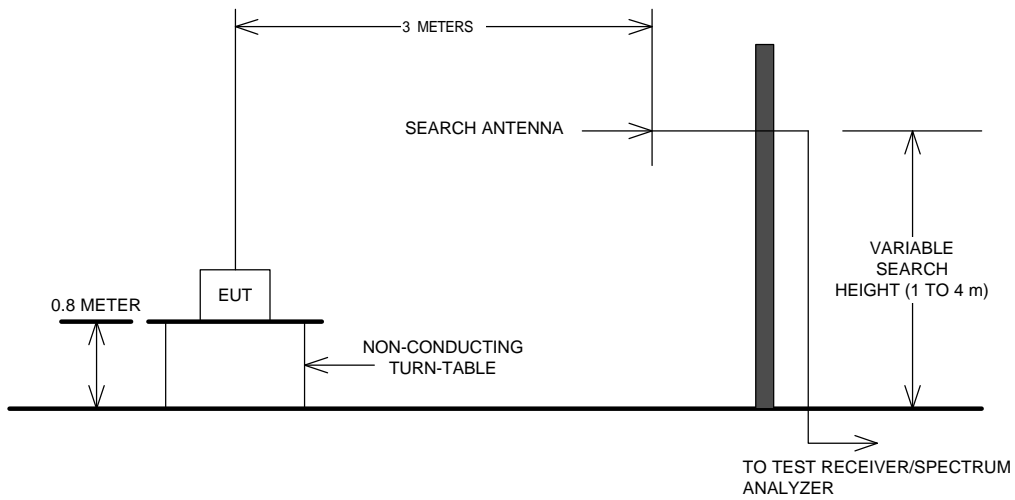

*EQUIPMENT: SKYROUTE Cellemetry Transceiver*  
*FCC ID: PED-SKYROUTE1*

---

**Section 6. Test Equipment List**

CAL CYCLE	EQUIPMENT	MANUFACTURER	MODEL	SERIAL	LAST CAL.	NEXT CAL.
1 Year	Spectrum Analyzer	Hewlett Packard	8565E	FA000981	June 08/01	June 08/02
3 Year	RF Millivoltmeter	Rohde & Schwarz	URV5	FA001570	July 3/00	July 3/03
3 Year	Power Sensor	Rohde & Schwarz	URV5-Z5	FA000419	Oct. 6/99	Oct. 6/02
1 Year	Horn Antenna	EMCO #2	3115	4336	Dec. 1/01	Dec. 1/02
1 Year	RF AMP	JCA	2-4 GHz	FA001496	COU	COU
1 Year	RF AMP	JCA	1-2 GHz	FA001498	COU	COU
1 Year	RF AMP	JCA	4-8 GHz	FA001497	COU	COU
2 Year	RF AMP	Narda	5 - 18GHz	FA001409	COU	COU
2 Year	Radiation Monitor	Narda	8616	FA000538	Jan 25/00	Jan 25/02
2 Year	Isotropic Probe	Narda	8621D	FA000538	Jan 25/00	Jan 25/02

NA: Not Applicable  
NCR: No Cal Required  
COU: CAL On Use