

Serial Flash

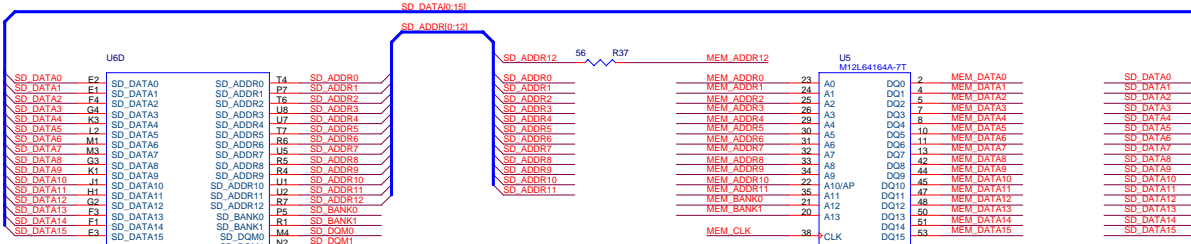

AR2315 Memory Interface

CONNECT SD_CLK_FB AT HALF WAY POINT OF SD_CLK

SDRAM

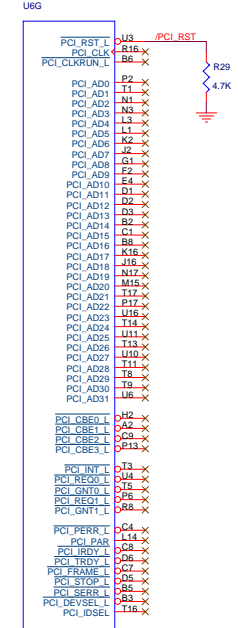
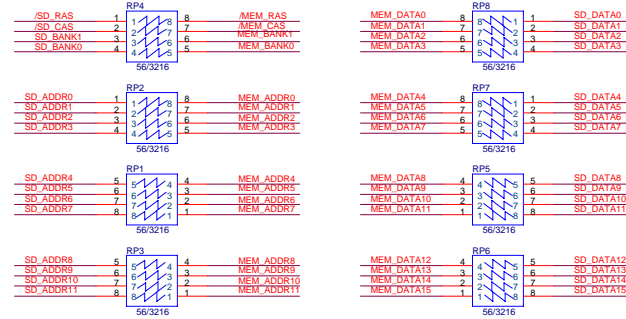

AR2315 PCI Interface

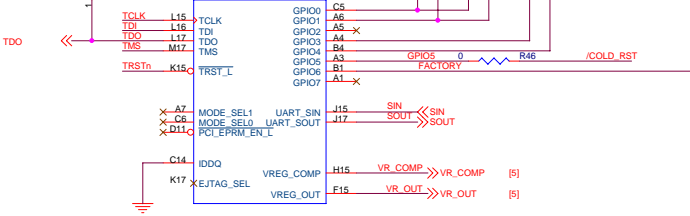

AR2315 UART, GPIO, EJTAG

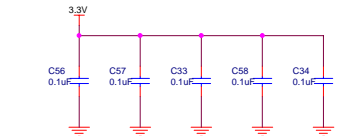
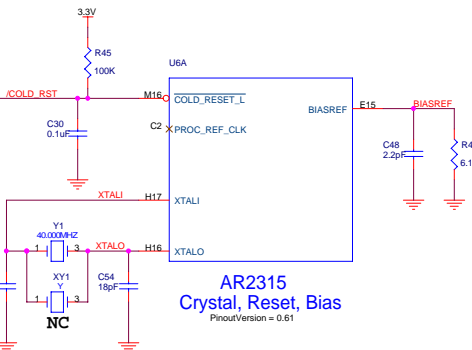
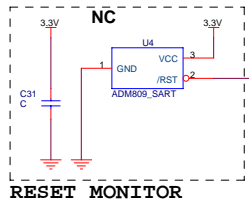
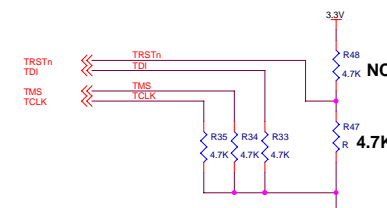

Acrowave Systems Co., Ltd.		
MEMORY		
Size	Document Number	Rev
C		0.1
Date	Sunday, October 23, 2005	Sheet 2 of 6

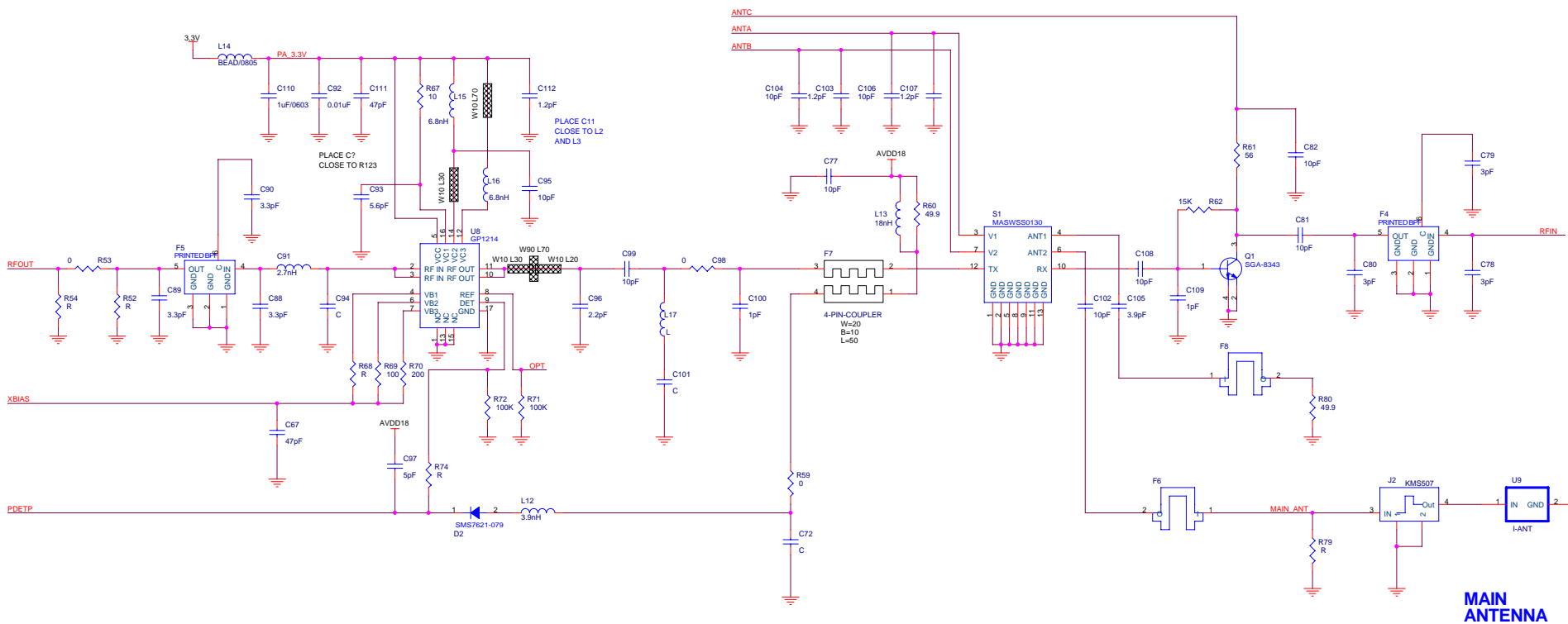
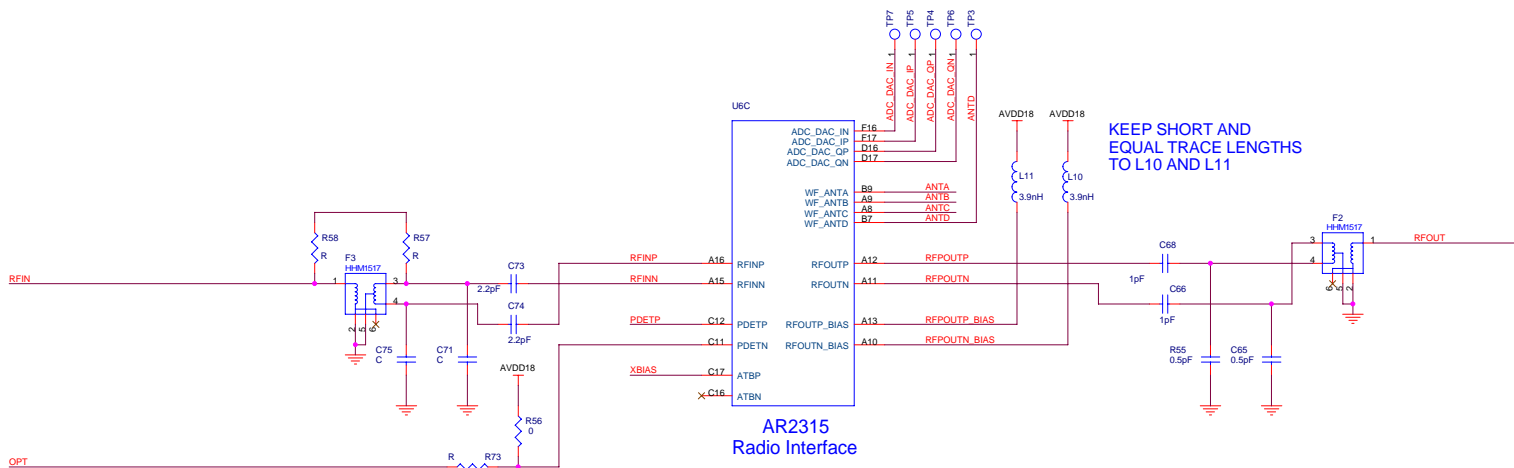

Acrowave Systems Co., Ltd.		
File		
RF Part		
Size	Document Number	Rev
C		0.1
Date	Sunday, October 23, 2005	Sheet 3 of 6

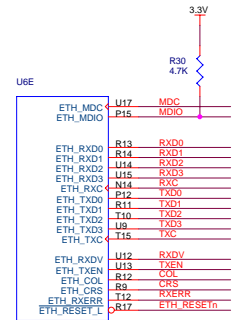

AR2315
MII Interface

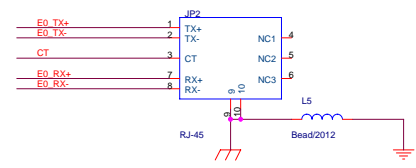
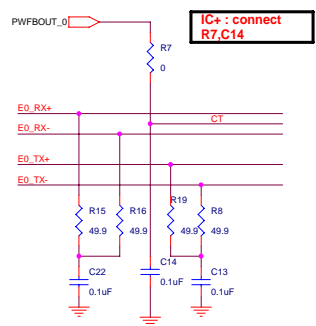
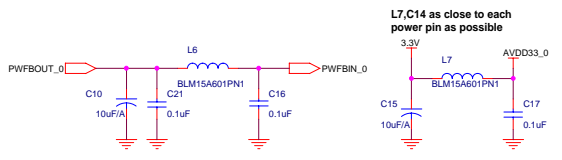
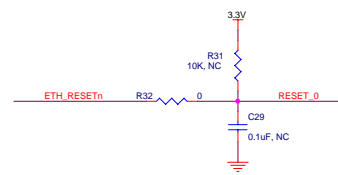
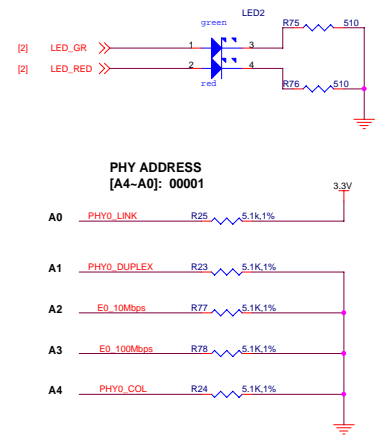
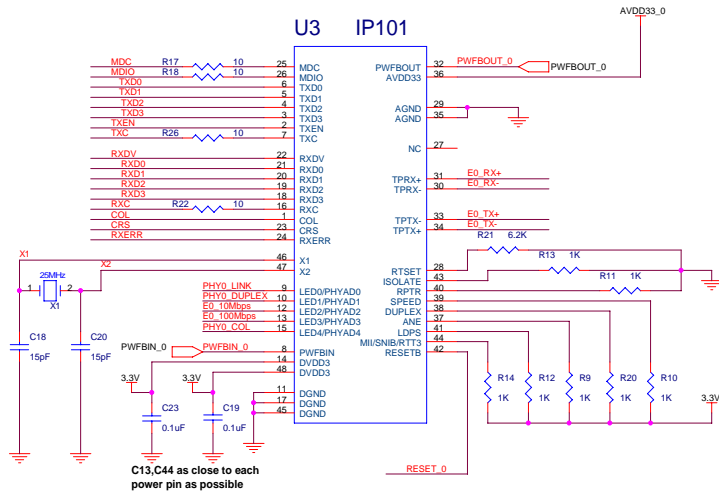

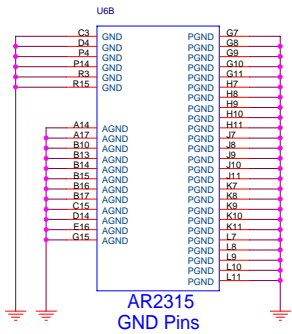

GROUND PINS

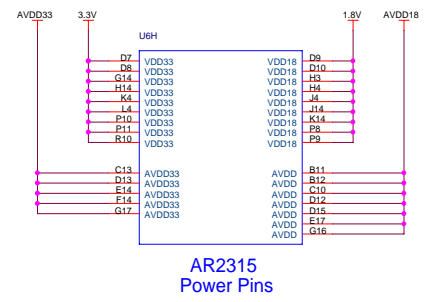

POWER PINS

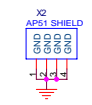
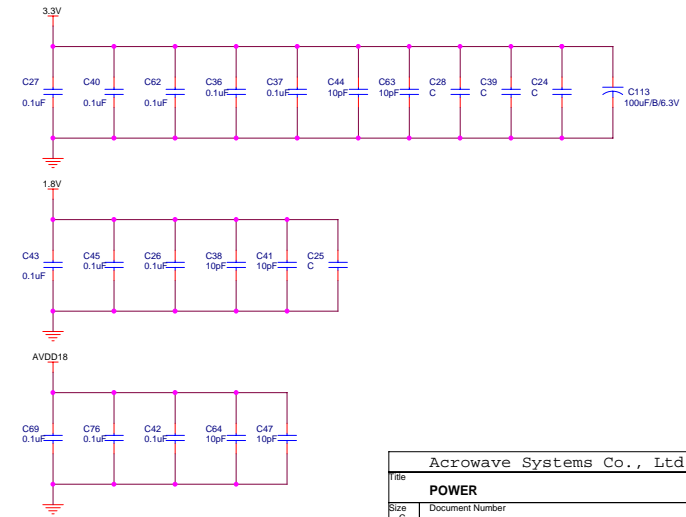
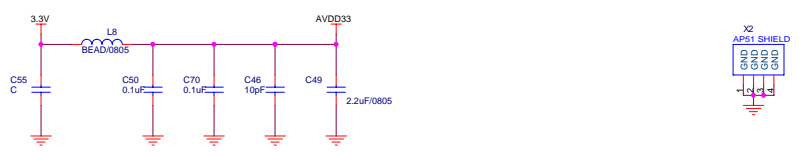
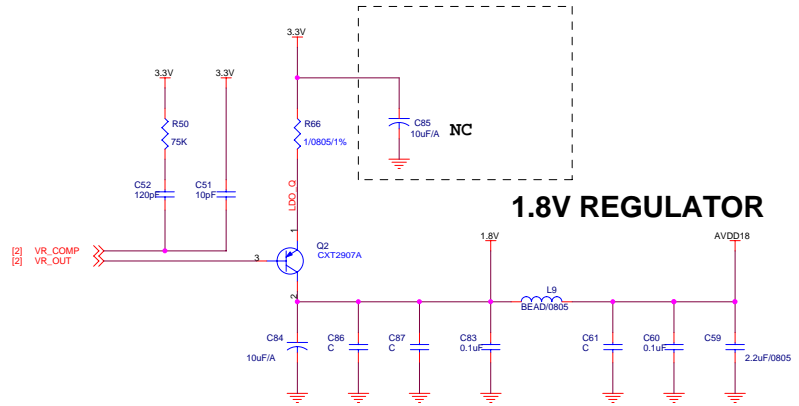
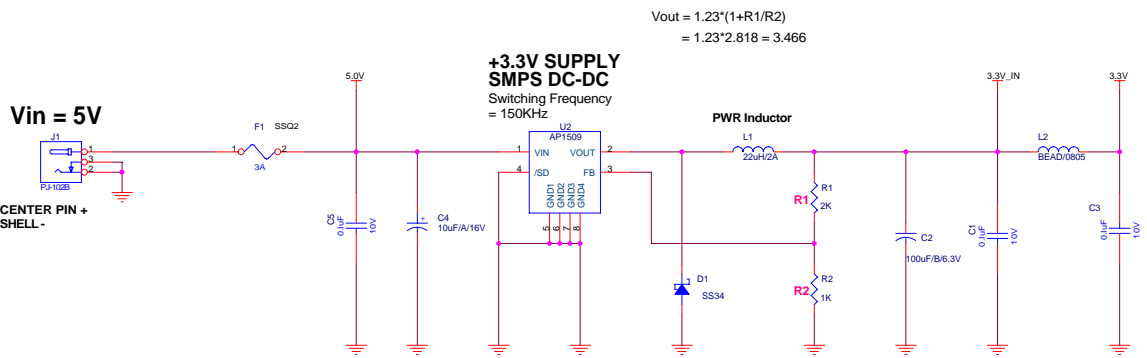
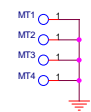

Acrowave Systems Co., Ltd.		
File	POWER	
Size	Document Number	Rev
C		0.1
Date	Sunday, October 23, 2005	Sheet 5 of 6

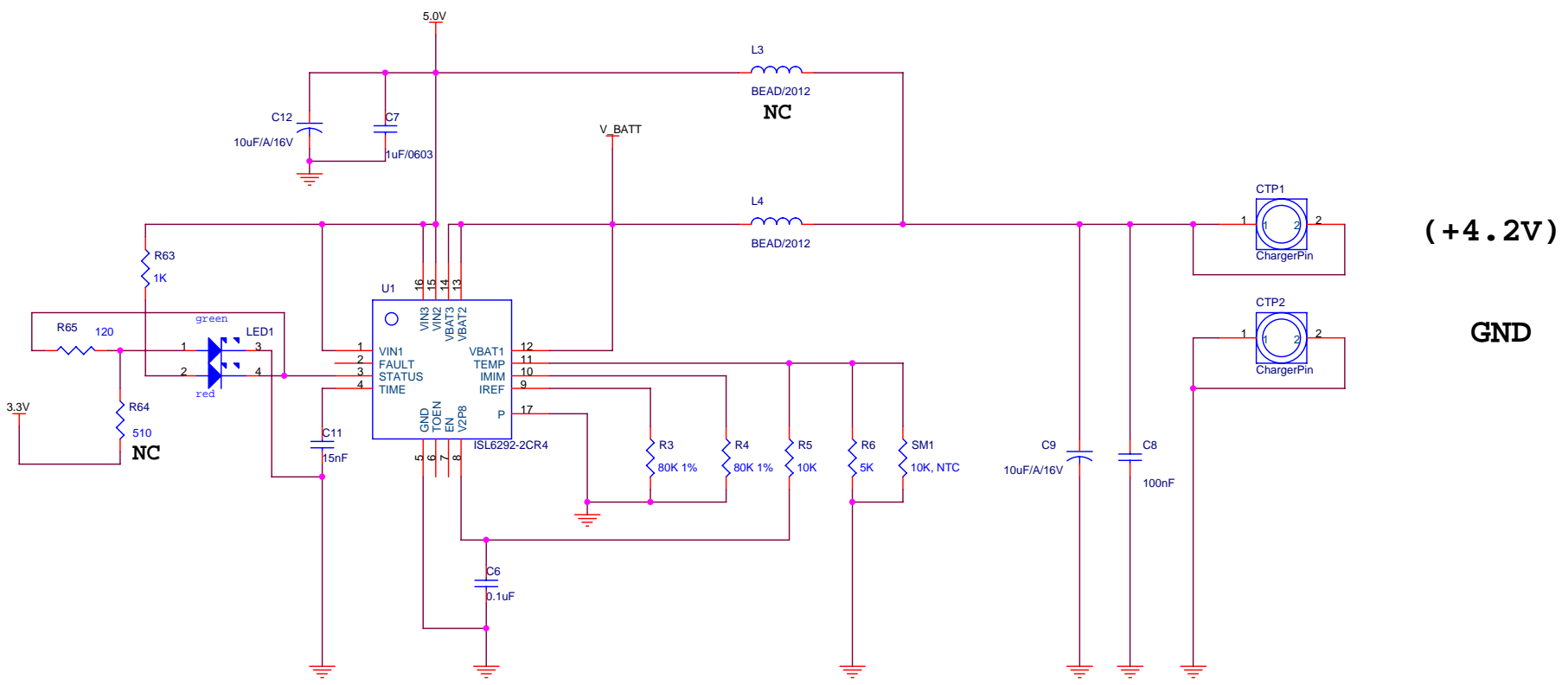

Title			
Charge Part			
Size B	Document Number	Rev 0.1	
Date:	Sunday, October 23, 2005	Sheet 6	of 6