

DESIGN		CUSTOMER	
		Widelink	
CHECK-1		WAP-1100E_MAIN (MPC860)	REV.
CHECK-2			R3
DATE		UPDATE	SHEET
			1/5
REMARK			

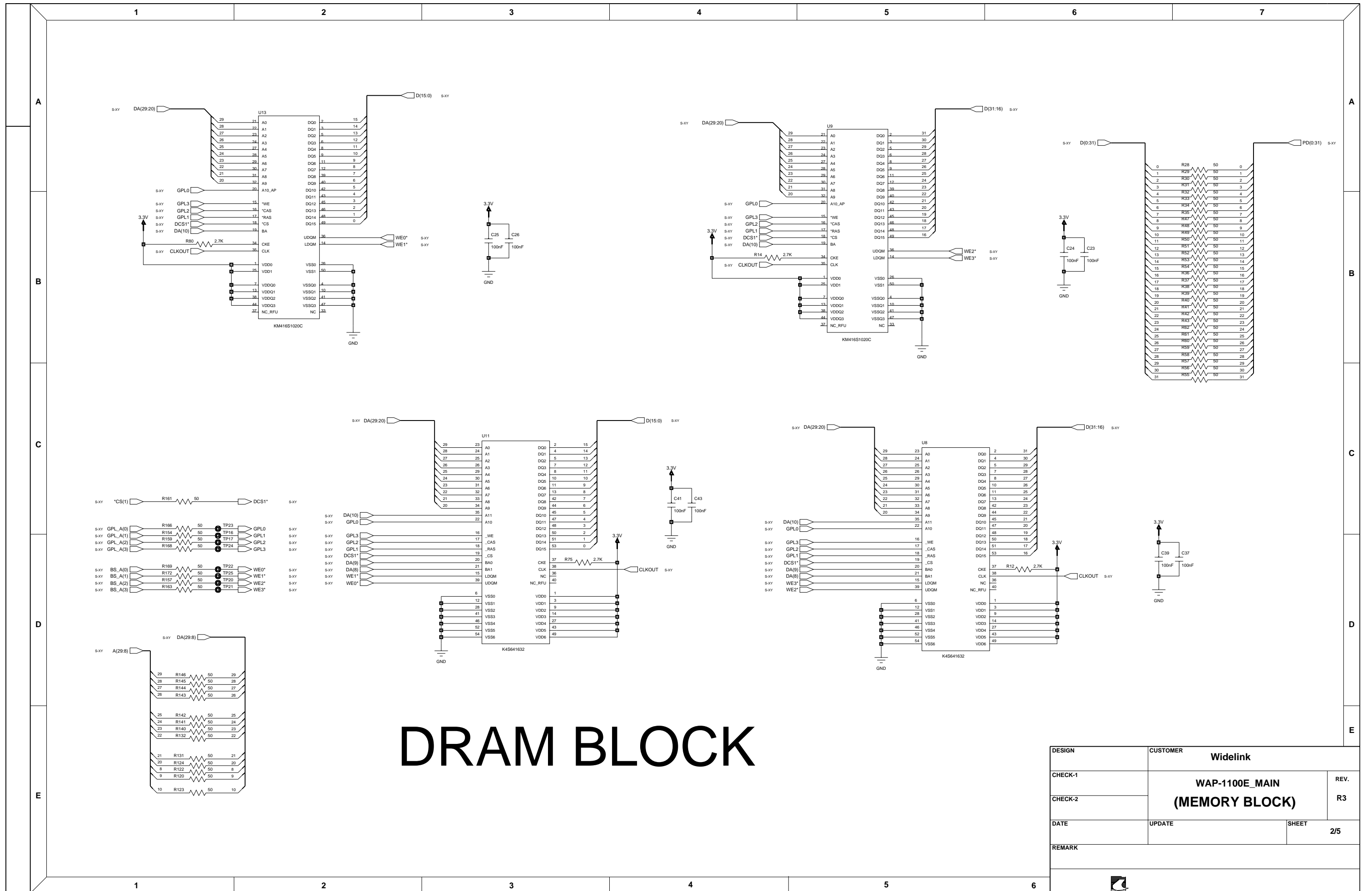

DRAM BLOCK

DESIGN	CUSTOMER		Widelink	
CHECK-1	WAP-1100E_MAIN			REV.
CHECK-2	(MEMORY BLOCK)			R3
DATE	UPDATE	SHEET	2/5	
REMARK				

FLASH ROM BLOCK

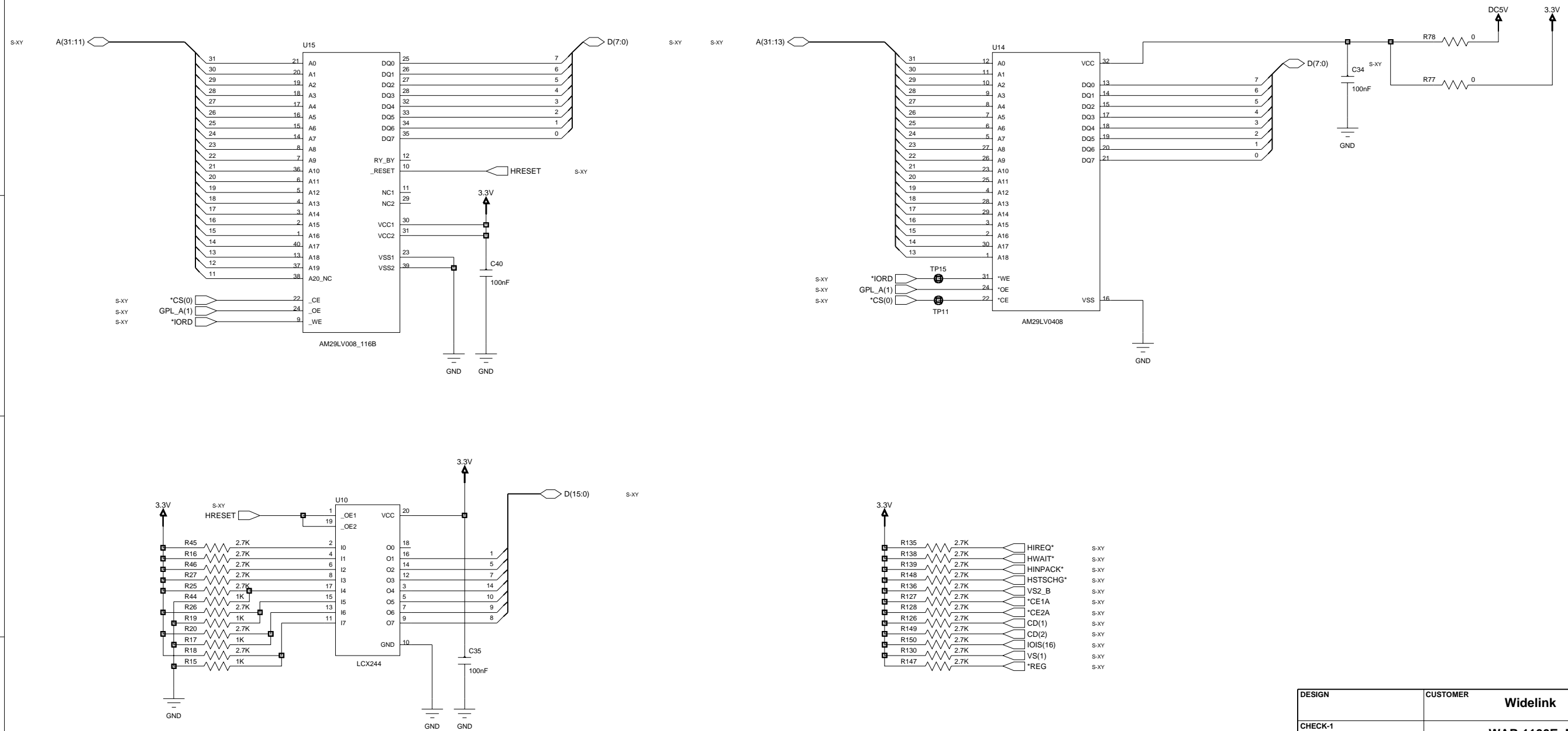

DESIGN	CUSTOMER		Widelink
CHECK-1	WAP-1100E_MAIN		REV.
CHECK-2			R3
DATE	UPDATE	SHEET	3/5
REMARK			

DC/DC POWER

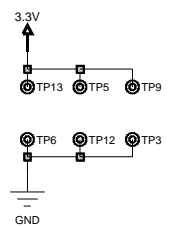
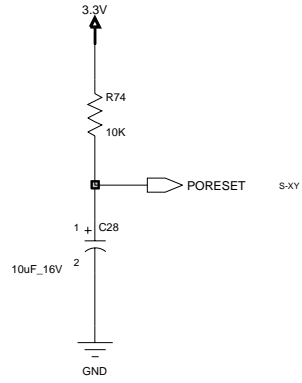
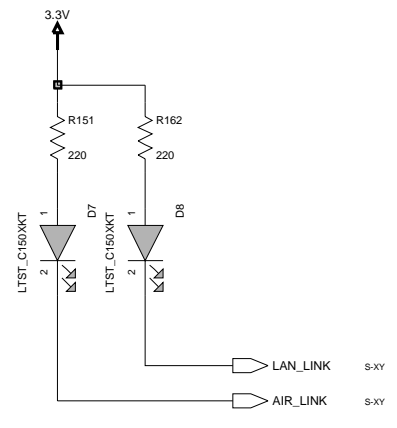
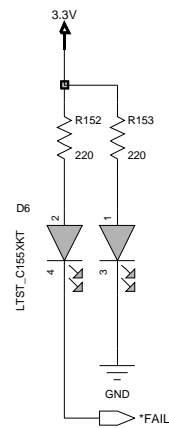
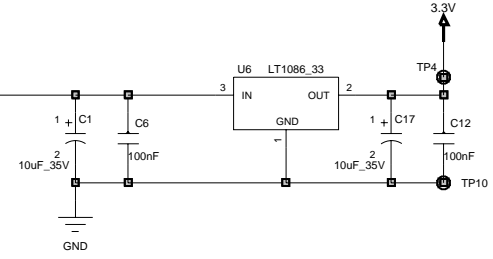
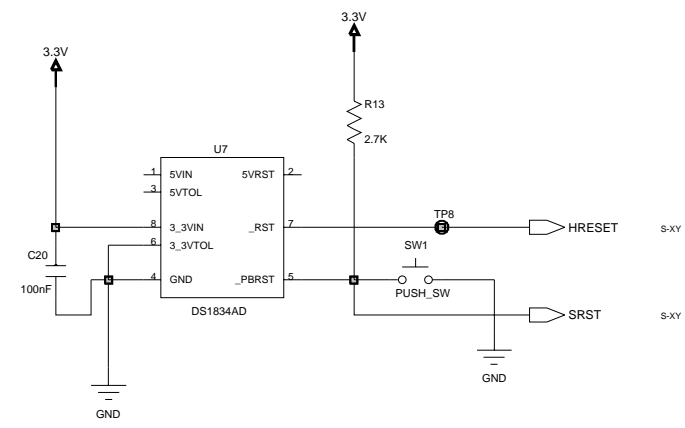
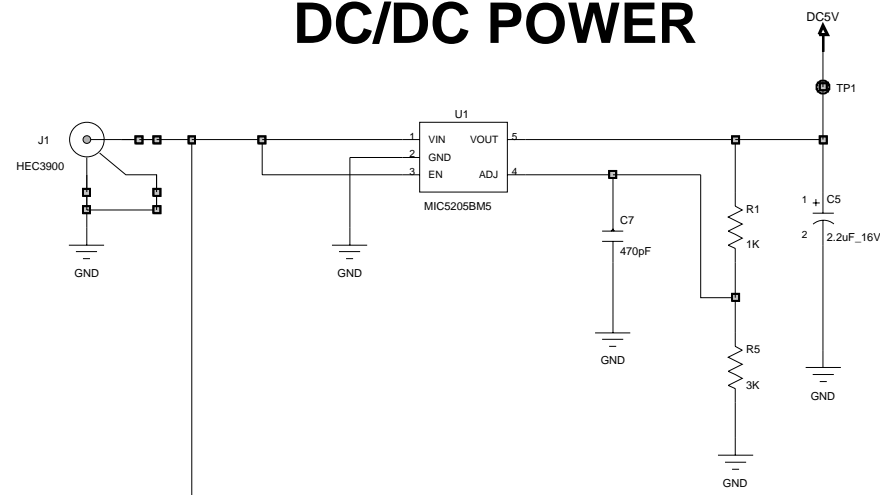

DESIGN	CUSTOMER Widelink		
CHECK-1	WAP-1100E_MAIN (RESET&POWER)		REV.
CHECK-2			R3
DATE	UPDATE	SHEET	4/5
REMARK			



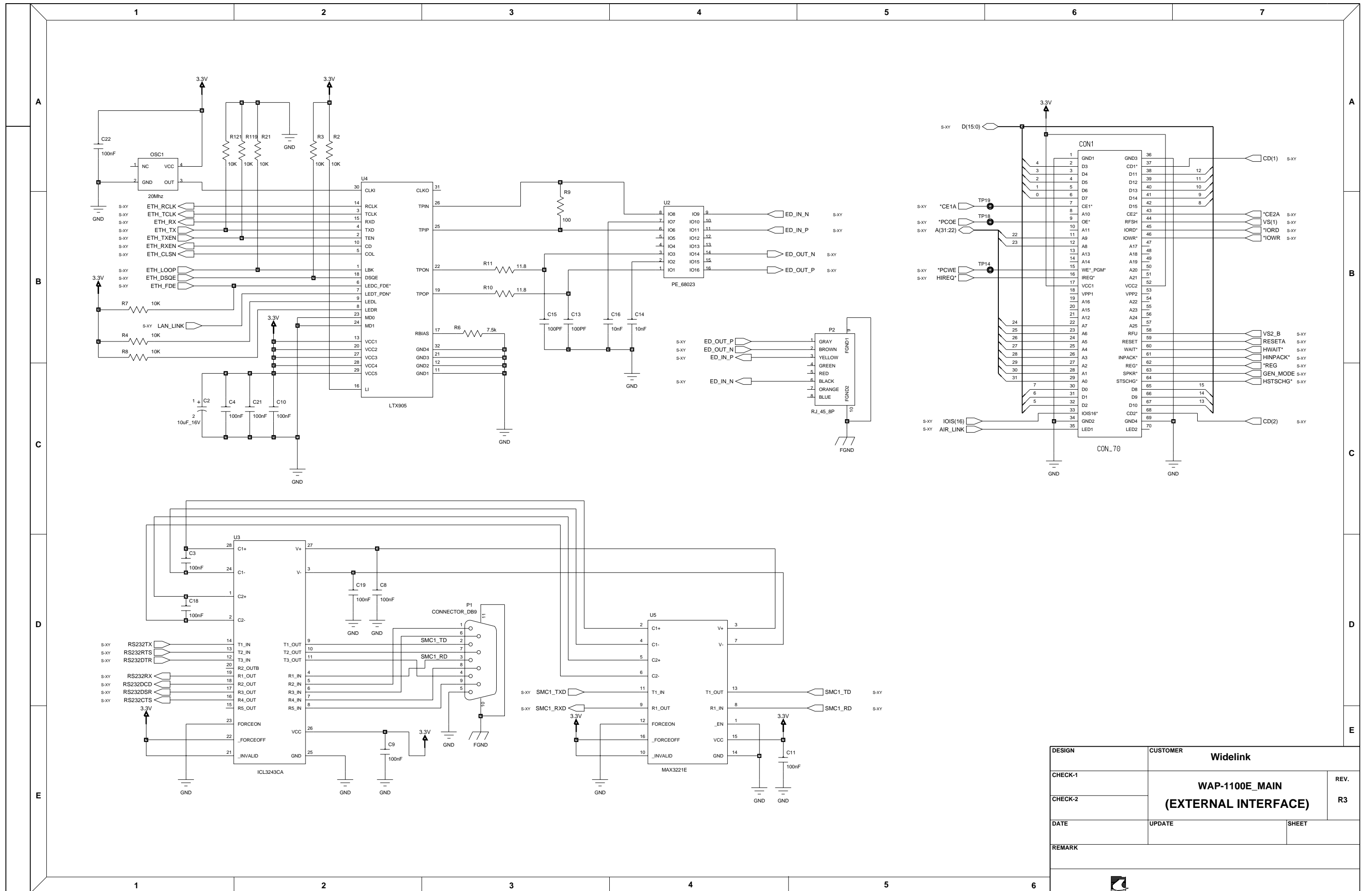

DESIGN	CUSTOMER		Widelink	
CHECK-1	WAP-1100E_MAIN (EXTERNAL INTERFACE)			REV.
CHECK-2				R3
DATE	UPDATE	SHEET		
REMARK				

