

@Road *iWM*3100 Series Installation Guide

Important – Please Read!

Following the simple steps below will ensure optimum performance of your *iWM* unit.

Should you have questions, please contact @Road Customer Service toll-free at 1-877-4-AtRoad (1-877-428-7623).

FCC RF Exposure Information

Warning: The antenna supplied with this device must be used for installation and operation. Substitution of other antennas must be approved by the manufacturer for compliance to radiation safety limits. The mounting of this device and antenna must be done by professional installers to ensure that the user or nearby persons will maintain at least 20 cm from the antenna in normal use.

Cautions: All persons must maintain a separation distance at least 20 cm from modem antenna when transmitter is operating to meet FCC RF exposure requirements.

BEFORE THE INSTALLATION

➤ Gather Components

Please ensure you have the following items are together before beginning the installation. There should be one complete set for each vehicle being installed. If any items are missing, contact a local Agent or @Road immediately.

1. WM31XX Unit
2. Power Cable
3. Installation Parts Kit
4. One of following Antenna options,
 - Option A: separate GPS and GSM “on glass” antenna
 - Option B: one-piece permanent roof mount antenna
 - Option C: Limo/Lip mount: one-piece trunk lip mount antenna
 - Option D: Flush/Surface mount GPS/Wireless antenna
 - Option E: Glass mount GPS/Wireless antenna

- 5. WLAN antenna
- 6. Installation Information Sheet, 4 part carbon (packaged with *iWM* Unit)



The use of any items except for those provided by @Road or authorized @Road installers might result in damage to the unit or impaired accuracy to the service. Make sure to only use the items shipped with the *iLM* unit as listed above or @Road-provided accessories.

➤ **BEFORE YOU CONTINUE Verify/Match Unit to Correct Vehicle**

NOTE: Some *iWM*'s are pre-matched to vehicle by number. This must be known before beginning the installation.

- 1) Check with the customer to see if vehicles were pre-matched by name/VIN/Serial Number.
- 2) Fill out the Installation Information Sheet noting *iWM* ID's to Vehicles by VIN, License or Car Number. This information is required for the customer to track their vehicles.

*iWM*3100 Assembly and External Interface Detail

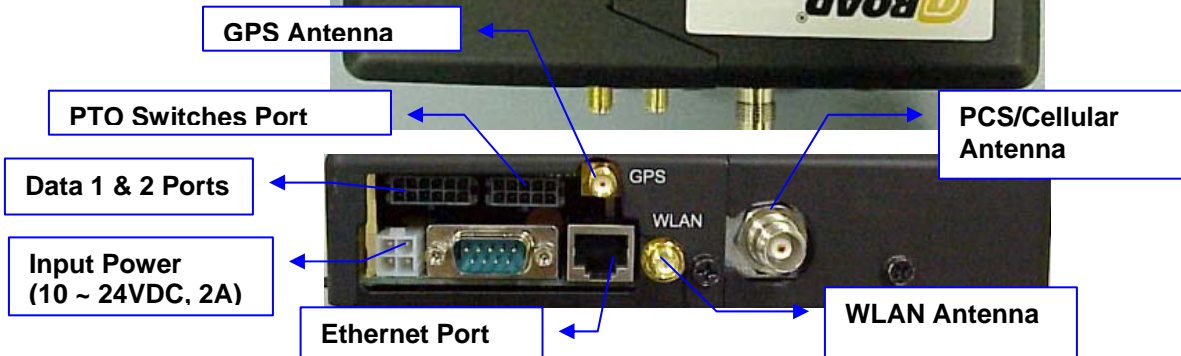

BEGINNING THE INSTALLATION

1) Choose a Location

Determine the best location to install the *iWM* unit. Recommendations are:

- In the trunk, where luggage and other items will not come into contact with the unit
- Behind or under the seats
- Under or behind the dashboard
- Behind the left or right kick-panels
- In the console (side or overhead)
- In the glove compartment/glove box
- Hidden from driver's view when possible, to limit driver tampering

PLEASE NOTE:

Placement should:

- Avoid direct sunlight
- Provide minimal exposure to dust
- Ensure minimal exposure to moisture
- Never be installed in engine compartment (Unit is designed to be installed inside the vehicle)



CAUTION

Functionality of the unit may be impaired by improper placement. Make sure to place the unit where recommended, as listed above.

2) Mount the *iWM* Unit

The *iWM* should be mounted using screws or tie-wraps

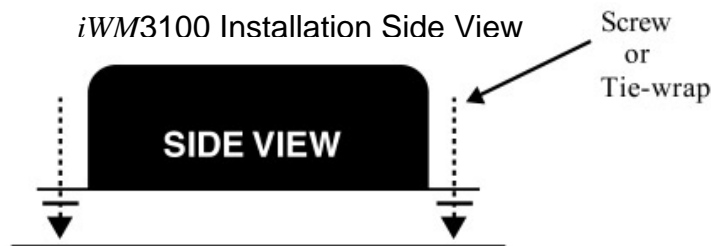

3) Hook Up Power



CAUTION

It is essential that you follow these steps exactly, as any inaccuracies may cause hardware damage and the @Road system to malfunction.

The *iWM* should be connected directly to a known 12V-DC power source (range of 10 to 24VDC), either the column harness or battery of the vehicle. Although the unit has a built-in self-resetting fuse, the *iWM3100*'s power cable must be fused protected at the power source

on both the RED and WHITE power connections with the **10** amp fuses and fuse holders, included in the installation kit. Additionally, remember to place the tamper resistant sticker and a tie wrap over the cover of the fuse holder, as shown in the following picture, so that any tampering with power source wires can be easily detected.

Use a voltmeter to verify voltage and hook wires as indicated below.

- Black** → Ground
- Red** (fused, 10 Amps) → **to vehicle battery, unswitched (+), this wire must see at least 10 volts at all times, if not the unit will reset continually and send inaccurate information**
- White** (fused, 10 Amps) → To true ignition, 12V switched, there must be 12 volt power in the “on”, “start”, and “run” position.

All connections at the column harness must be made by either soldering bare wire to bare wire or using the poke and wrap method. *Note: T-taps, scotch locks, and like connectors are not permitted and must not be used to tie the iWM to its power source.*



1) Poke



2) Wrap



3) Insulate and wire tie

Tapping into ignition for the power source

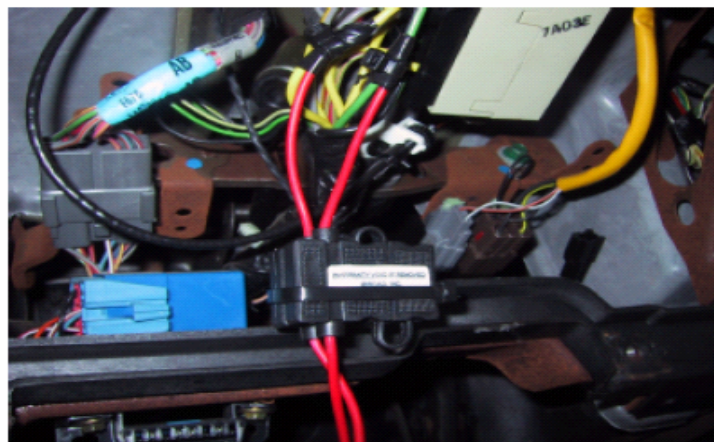

Please note how fuse holders are tamper proofed with tamper proofing stickers and a tie wrap.

4) Position GPS Antenna for Optimum Performance

To ensure best reception, install the GPS antenna in a location that provides a clear sky view (greater than a 90 degree angle view of the sky). Note: Mount antenna as far as possible (at least 2 feet) away from other antennas to minimize the possibility of interference.

 **CAUTION** When drilling holes, use of safety glasses is recommended.

SMALL VEHICLE
(A) BEST – Top of vehicle

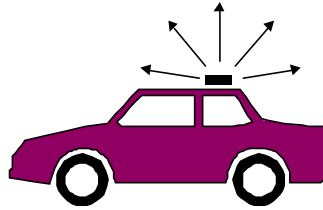

(B) Option – Dashboard of vehicle
(must be non-metallic)

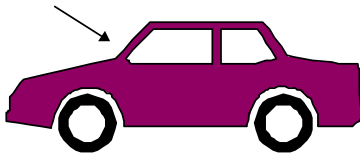

Could be on the dashboard or hidden under non-metallic dashboard. The antenna **must** face toward the sky.

(C) Option – Rear brake light compartment

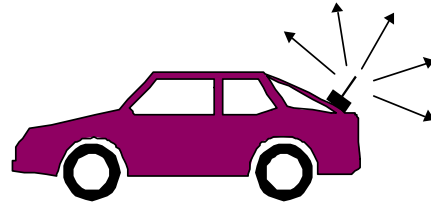

Place under the rear brake light. Can be accessed through the trunk. Only recommended when the rear window **has a steep slope**.

LARGE VEHICLE
(A) BEST – Top of the vehicle and as close to the front as possible

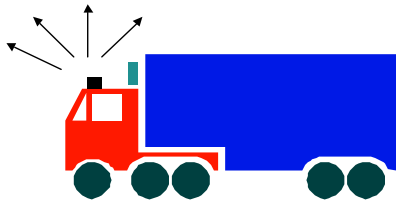

(B) OPTION – Middle of the roof

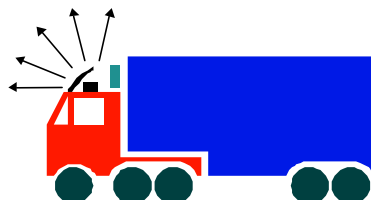

 **CAUTION** THIS POSITION NOT RECOMMENDED (due to restricted sky view)

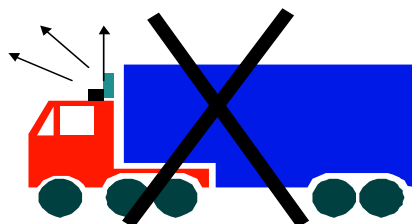

5) Connect GSM and WLAN Antenna (if separate GSM antenna or non-combo antenna)

The GSM antenna should be installed in an optimum location, to intercept the cellular signals, arriving at slightly above zero degrees from the horizon. Signals will typically penetrate through non-metal material such as glass, fiberglass, and aluminum. Please refer to the illustrations below.

Note: Mount antenna as far as possible (at least 2 feet) away from other antennas to minimize the possibility of interference.

(A) BEST – Top of vehicle

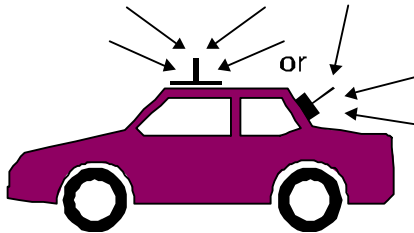

(B) Not Recommended – Inside the vehicle

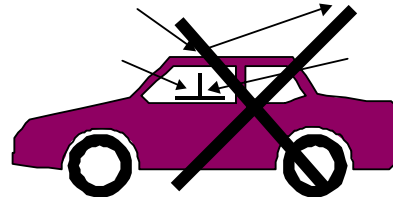

(May experience some lost signal strength)

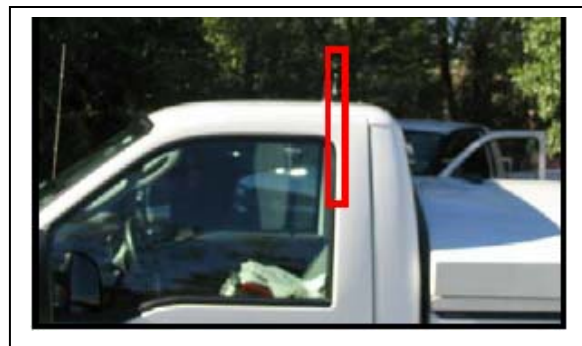
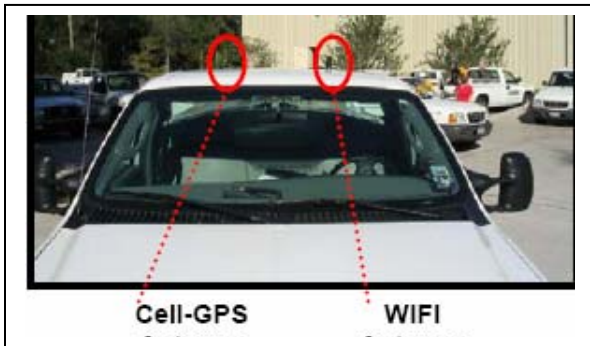

6) Power On the iWM



STEP 1: The vehicle or equipment must be outside, with a clear and unobstructed view of the sky, away from tall buildings that may interfere with the units GPS reception is also best.

STEP 2: Plug in the power connector and turn the unit on.

STEP 3: Once the unit is ON, within 15 minutes all four lights should be lit in the following:

(1) Status LED: Steady GREEN.

- (2) WAN LED: Steady GREEN.
- (3) WLAN LED:
 - OFF: No WiFi 802.11b device is connected to it.
 - ON Steady: Some WiFi 802.11b device is connected to it.
- (4) GPS LED: Steady GREEN

IMPORTANT
Please allow 15 minutes for complete initialization.
DO NOT MOVE the vehicle during this process

Information on the installer screen

The installer screen is designed to present the most important information in a clear, easy to follow format. If you have feedback on the presentation of the screen then please pass this back to @Road so that the screen information can be improved in future firmware releases. The information presented covers :

- Firmware version of the iWM
- IWM serial number
- Ignition sense state (ON/OFF)
- GSM signal and registration status
- GPS status (whether making position fixes, and whether tracking satellites)
- StatWhere switch status (ON/OFF)
- Configuration of the Data2 accessory port.

Screen Layout

The screen shows information in the format shown below. If the screen appears grossly different then you have an iWM with an earlier version of firmware, in which case you should press the VIEW key to return to normal operation since none of the information on earlier iWMs is useful to customer satisfaction group or for general installation purposes.

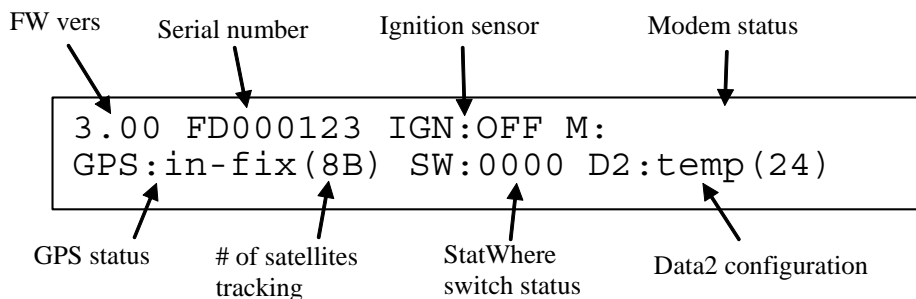

Most of this screen is quite intuitive. However, below is a complete description of the fields and how they can help in troubleshooting an installed unit :

GSM status values

- **Registered** : this is a normal operating mode. The modem has a good radio signal and is registered.
- **Reg-wk-sig** : The GSM modem is registered, and the iWM will operate normally, but the radio signal strength is marginal. This is most likely due to poor GSM coverage but could also indicate a bad/damaged GSM antenna.
- **Good signal** : The modem is not registered. The iWM will not transmit or receive data. If the signal remains strong for several minutes, but the status does not change to “registered” then there may be a problem with the IP address. Contact @Road customer satisfaction and report the condition.
- **Weak signal** : The modem is not registered and has a weak signal. This is most likely due to being in an area of poor coverage, but may indicate a problem with the GSM antenna or the IP address. The iWM will not transmit or receive data in this state so @Road customer satisfaction should be contacted.

GPS Status values

The GPS status comprises a description, followed by a number (0-8) and a letter A or B in brackets. The letter is for engineering diagnostics only, but should be reported to customer satisfaction when reporting trouble with a unit.

- **In-fix (7A)** : The GPS module is performing position fixes, and is tracking 7 satellites. This is the normal operating mode. (The actual number of satellites tracked may vary between 4 and 8 when in this mode, the greater the better).
- **Tracking (3B)** : The GPS module is tracking satellites, but is not performing position fixes. In a stationary vehicle the unit may take up to 60 seconds to start to make position fixes when it is tracking satellites. If, after 60 seconds, the unit is still not making position fixes then this is most likely due to not tracking enough satellites (at least 4 must be tracked). This may be due to bad placement of the GPS antenna, or may be because the vehicle is parked in an area of bad coverage (e.g. next to a tall building or under trees. However in this state it is certain that the GPS module is functioning correctly.
- **No-track (0A)** : This indicates that the GPS module is not tracking any satellites. A new unit should start to track satellites within 60 seconds of having the power applied. If not then likely problems are that the vehicle may be parked in a bad location, the GPS antenna may be badly placed, with a limited view of the sky, or the GPS antenna may not be connected fully to the iWM. It is very rare that the problem is in the iWM itself, since this is tested at the factory.

StatWhere switch status

The switch status shows 4 digits which are either 0 (switch not activated) or 1 (switch activated). By activating the switch while observing the display it is possible to confirm that the iWM is correctly sensing the state of the switches.

Data2 status

This field shows which peripheral the iWM is expecting to have connected to data2. If it is configured to be the temperature sensor then the display will also show the current temperature of the sensor in degrees Celsius. (To perform a rough conversion from Celsius to Fahrenheit multiply by 2 and add 32. E.g. 25 C is approximately 82 F).



**How to Contact @Road
US Support and Service**

Voice: 1-877-428-7623 **Fax:** 1-510-353-1442

Email: support@road-inc.com **Web site:** <http://www.road.com>

At Road, Inc. Headquarters
47200 Bayside Parkway
Fremont, CA 94538
Tel: 510.668.1638
Fax: 510.353.6021
Toll Free: 1.877.4AtRoad

Find @Road on the World Wide Web at: <http://www.road.com/>

Copyright © 2003 - 2004 by At Road, Inc. @Road and *iWM* are registered trademarks of At Road, Inc. The @Road logo, www.road.com, www.atroad.com, GeoManager, *iDT*, *iTM*, Pocket Edition and @Road Pathway are trademarks and/or service marks of At Road, Inc. All other trademarks and/or service marks used are the property of their respective owners.

@Road reserves the right to make changes at any time, in order to improve the reliability, function or design of its devices, products or services and to supply the best devices, products and services possible. @Road devices, products and services are protected under one or more of the following U.S. Patents: 5,477,228; 5,694,594; 5,959,577; 5,990,827; 6,459,988; 6,529,159; 6,552,682; 6,594,576, and numerous patents pending. @Road does not represent that the devices, products or services shown or described herein are free from patent infringement or from any other third party right. @Road assumes no obligation to correct any errors contained herein or to advise any user of liability for the accuracy or correctness of any engineering software support or assistance provided to a user.

The @Road devices, products and services are dependent on the coverage and calling areas of wireless networks owned and operated by third parties. Coverage and calling areas are approximate and do not cover significant portions of the United States. Actual coverage and operation of the devices, products and services depend on a variety of factors, including without limitation, system availability and capacity; system and equipment upgrades, repairs, maintenance, modifications and relocation; user's equipment; terrain; signal strength; structural conditions; weather and atmospheric conditions; availability of power; governmental regulations; suspected fraudulent activities; acts of God and other conditions beyond the reasonable control of @Road. @Road will not be responsible for limits in coverage or performance degradation due to any such conditions. The user acknowledges that coverage and calling areas may be interrupted, halted, or curtailed or the quality of the transmission may be diminished at any time.

The devices, products and services are dependent upon the availability of the Internet, which is owned and operated by and accessed through third parties. @Road assumes no responsibility for improper storage of data or information or delivery of messages. The user assumes the entire risk in downloading or otherwise accessing any data, information, files or other materials obtained from the @Road website, even if the user has paid for or otherwise been provided virus protection services from @Road.

The @Road devices, products and services and any modifications, alterations, additions or changes to the devices, products or services, are not fault tolerant and are not designed, manufactured or

intended for use in life support, emergency, mission critical or other ultra-hazardous activities (“High Risk Activities”). @Road specifically disclaims any express or implied warranty of fitness for such High Risk Activities. Use of an @Road device, product or services in any application without the written consent of @Road is prohibited.

All customer information is governed by the @Road Privacy Policy located on the @Road website at www.road.com.

Notice of Rights

All rights reserved. No part of this book may be reproduced or transmitted in any form by any means, electronic, mechanical, photocopying, recording, or otherwise, without the prior written permission of At Road, Inc. For information on getting permission for reprints, contact Bridgette Birdie at At Road, Inc. Headquarters.

Notice of Liability

The information in this book is distributed on an “As Is” basis, without warranty and was current at the time of publication. While every precaution has been taken in the preparation of the manual, @Road will not have any liability to any person or entity with respect to any loss or damage caused or alleged to be caused directly or indirectly by the instructions contained in this manual or by the software and hardware products described in it.

Privacy and Use

This product is intended to monitor and make available information concerning the end-user’s activities. It is the customer’s sole responsibility to ensure that its use complies with any applicable laws and regulations. The end-user can disable the application at any time by quitting the @Road application. It is the customer’s responsibility to develop and communicate policies concerning use of the application and the end-user’s ability to disable the application prior to implementing the product. Customers are urged to consult with their own counsel in connection with the particular use to which the customer puts the product and the potential implications from that use. Handsets should not be used while driving. Users should comply with all terms, conditions, obligations, instructions, directions, and requirements of the manufacturers and/or distributors of handsets used in conjunction with the @Road service.