

Regulatory WLAN Antenna Information

(English Language Required for Intel Regulatory Review / Approval)

OEM Vendor: CPBG

Platform: MS01 (with PCB Ass'y)

Antenna Vendor: FOXCONN

Antenna Sample / Antenna Data Requirements for worldwide regulatory approval

Section	Description of Required OEM / ODM Antenna Information	US / IC	EU	Japan	Taiwan	S.Korea
1A	Part Number for Antenna only	Required	Required	Required	Required	Required
1B	Antenna Manufacturer Name	Required	Required	Required	Required	Required
1C	Description of Antenna Type	Required	N/A	N/A	N/A	N/A
1D	Part number of Antenna Assembly / cable impedance, length & diameter.	Required	Desired	Desired	Desired	Desired
1E	Main & Aux antenna (Peak Gain W/ cable loss)	Required	Required	Required	Required	Required
	1E OR 1F, 1G, 1H					
1F	Main & Aux antenna (Peak Gain only)	Required	Required	Required	Required	Required
1G	VSWR of cable including connector	Required	Required	Required	Required	Required
1H	Main & Aux antenna (Cable loss W/ connector)	Required	Required	Required	Required	Required
2	Dimensioned Photographs and Drawings of main & auxiliary antennas	Required	Required	Required	Required	Required
3	Radiation patterns of antennas loaded in the host platform.	Required	Desired	Required	N/A	Required
4	Platform model name / number - correlated to antenna manufacturer and antenna part number	Required	Required	Desired	Required	Desired
5	Photograph(s) and Drawings showing location of antennas in platform. (S. Korea requires photographs of antennas for approval submission). Taiwan requires pictures of each antenna type shown in the system.	Required	Required	Desired	Required (Photos)	Required (Photos)
6	Mech. drawings / photos with dimensions of antenna locations and distance from end-user (For evaluation of SAR testing requirement).	Required	N/A	N/A	N/A	N/A
7	Photograph(s) or Drawings showing the location of all antennas (WLAN, BT, other) and distance between those transmitting antennas. Information will be used to evaluate whether co-location testing is required.	Required	N/A	N/A	N/A	N/A

Singapore: If product is shipping to Singapore the following is required:

- **Photograph of miniPCI card location in laptop to determine if it is easily accessible by the user. (See Section 4. Host Platform Information).**

Antenna Information

Section 1. Antenna Assembly Specifications

Antenna Assembly Summary:

1A Antenna Part Number	1B Manufacturer	1C Antenna Type	1D Cable Assembly Part Number and Information	1E Peak Gain W/ Cable &PCB Ass'y loss (dBi)	1F Peak Gain w/o Cable Loss (dBi)	1G VSWR	1H Cable Loss (dBi)
(P/N:WDAN-FC MS1001) Main antenna	HON HAI PRECISION IND. CO.,LTD.	PIFA	(P/N: SGX0001) 50 ohm Coaxial. length: 615 mm diameter: 1.13mm Connector: SGX	2400-2500MHz -2.17 dBi (peak)	2400-2500MHz -0.5 dBi (peak)	2400-2500MHz 2.0 max	2400-2500MHz 1.670dBi (peak)
				5150-5350MHz -0.55 dBi (peak)	5150-5350MHz 1.99 dBi (peak)	5150-5350MHz 2.0 max	5150-5350MHz 2.516dBi (peak)
				5725-5875MHz -1.42 dBi (peak)	5725-5875MHz 1.22 dBi (peak)	5725-5875MHz 2.0 max	5725-5875MHz 2.640dBi (peak)
(P/N:WDAN-FC MS1002) Auxiliary antenna	HON HAI PRECISION IND. CO.,LTD.	PIFA	(P/N: SGX0001) 50 ohm Coaxial. length: 920 mm diameter: 1.13mm Connector: SGX	2400-2500MHz -2.85 dBi (peak)	2400-2500MHz -0.352 dBi (peak)	2400-2500MHz 2.0 max	2400-2500MHz 2.498dBi (peak)
				5150-5350MHz -2.74 dBi (peak)	5150-5350MHz 1.024 dBi (peak)	5150-5350MHz 2.0 max	5150-5350MHz 3.764dBi (peak)
				5725-5875MHz -2.7 dBi (peak)	5725-5875MHz 1.25 dBi (peak)	5725-5875MHz 2.0 max	5725-5875MHz 3.950dBi (peak)

1A Antenna Part Number	1J PCB Ass'y loss (dBi)	1K Peak Gain w/o Cable & PCB Ass'y Loss (dBi)	
(P/N:WDAN-FC MS1001) Main antenna	2400-2500MHz 0.69 dBi (peak)	2400-2500MHz 0.19 dBi (peak)	
	5150-5350MHz 1.8 dBi (peak)	5150-5350MHz 3.79 dBi (peak)	
	5725-5875MHz 1.5 dBi (peak)	5725-5875MHz 2.72 dBi (peak)	
(P/N:WDAN-FC MS1002) Auxiliary antenna	2400-2500MHz 0.69 dBi (peak)	2400-2500MHz 0.338dBi (peak)	
	5150-5350MHz 1.8 dBi (peak)	5150-5350MHz 2.842dBi (peak)	
	5725-5875MHz 1.5 dBi (peak)	5725-5875MHz 2.75 dBi (peak)	

Section 2. Dimensioned Photos and Drawings of Antennas

Include a dimensioned photo and dimensioned drawing of main antenna here.

Main Antenna Dimensioned Drawing:

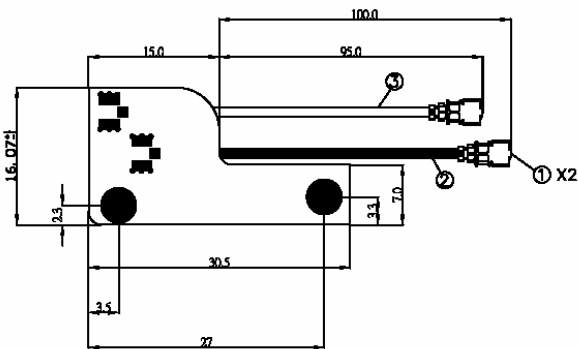
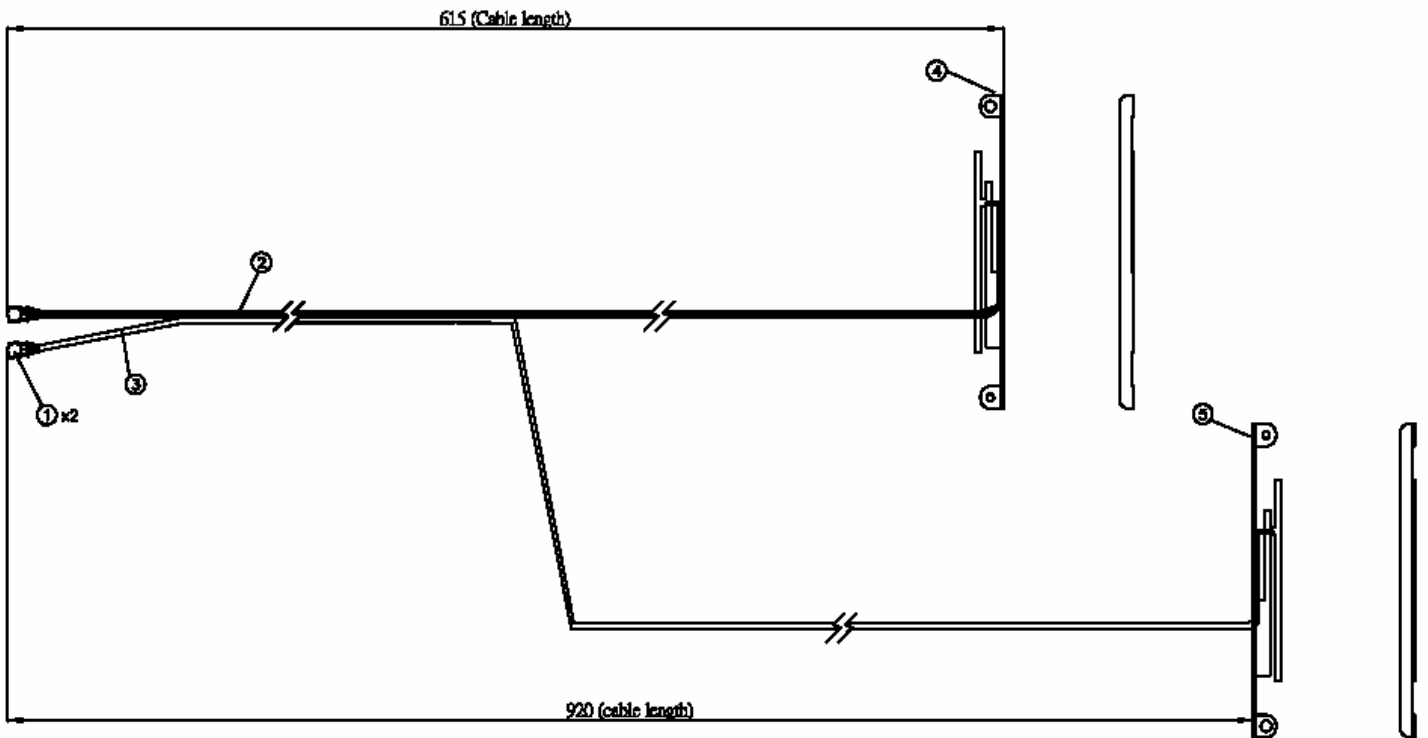

Main Antenna Photo:

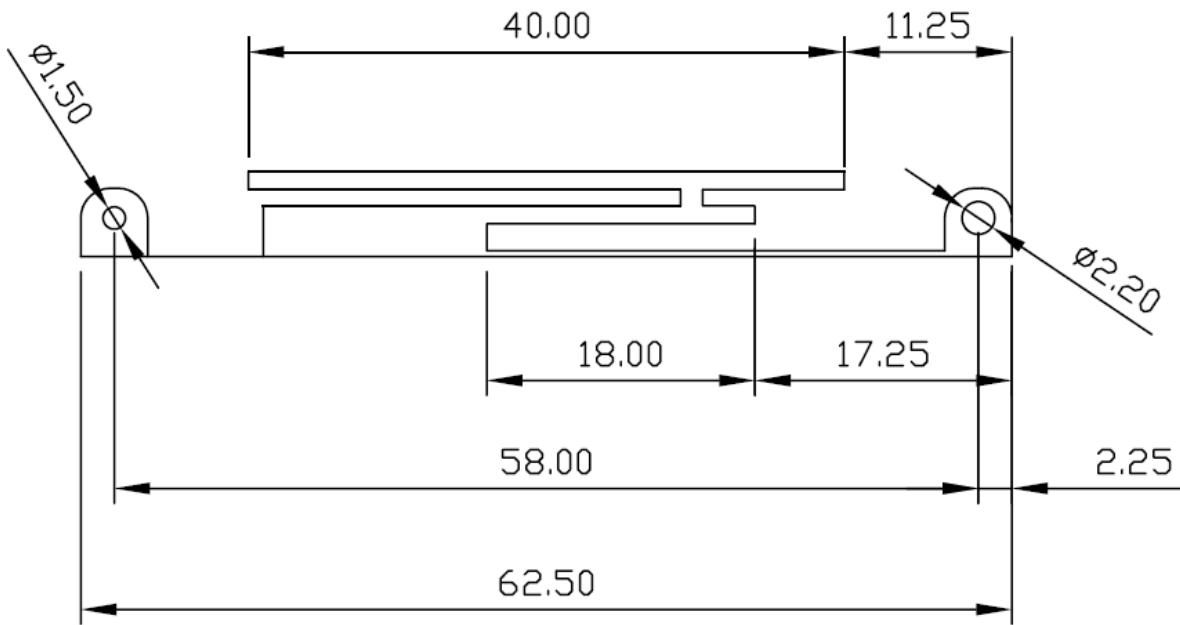

Include a dimensioned photo and dimensioned drawing of aux antenna here.

Aux Antenna Dimensioned Drawing:

(Please see the drawing of Main Antenna.)

Aux Antenna Photo:

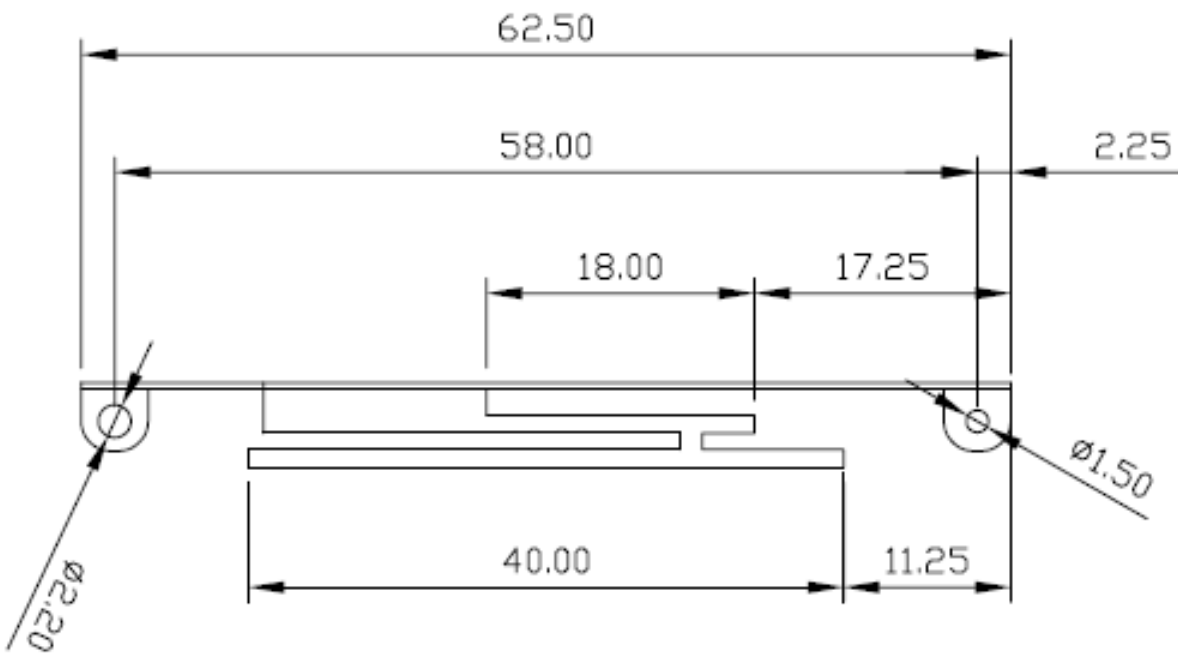

Section 3. Radiation characteristics of antenna Loaded in Host Platform

2400-2500MHz radiation characteristic

Main antenna: 2400 MHz

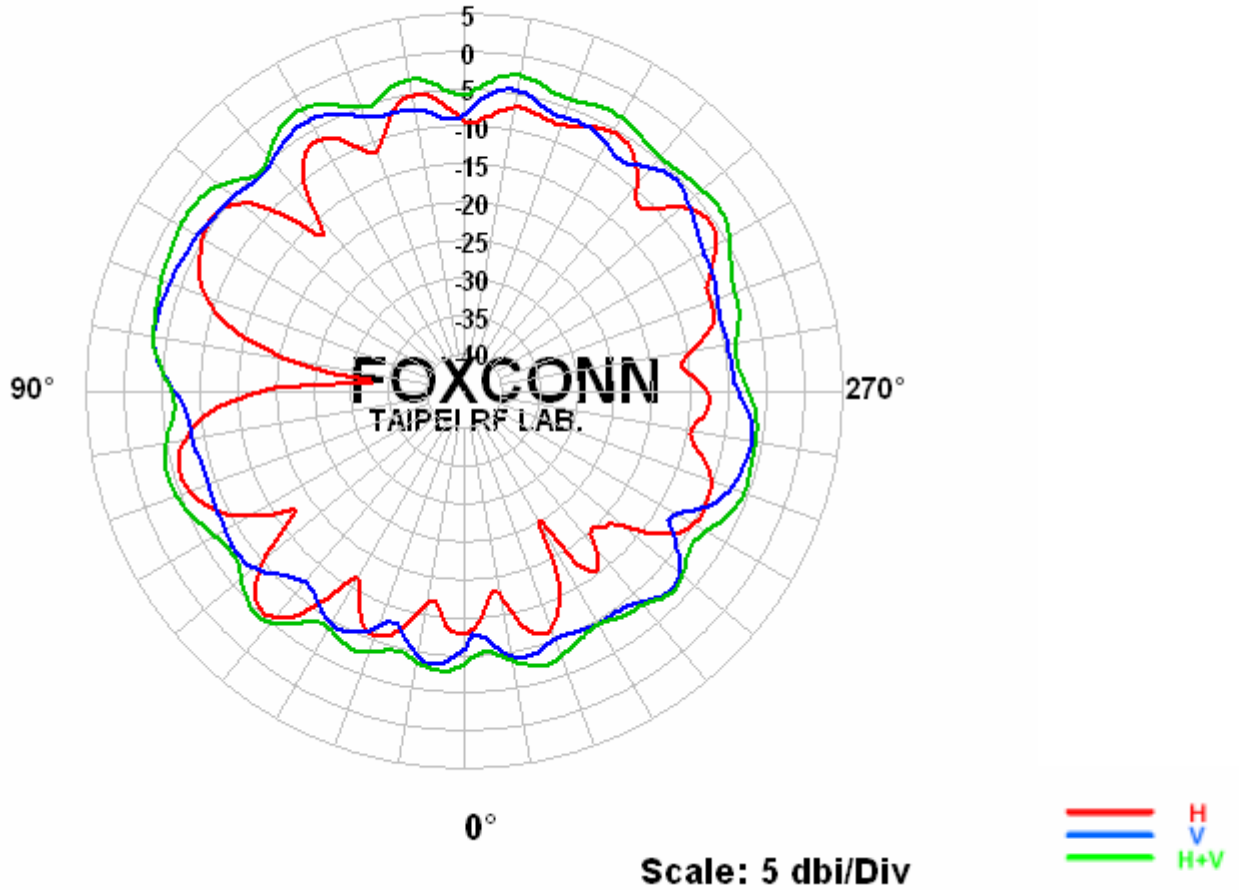

Center Frequency	2400 MHz
Horizontal (dBi) peak	-4.45
Vertical (dBi) peak	-3.23
Horz+Vert (dBi) peak	-1.44

Main antenna: 2450 MHz

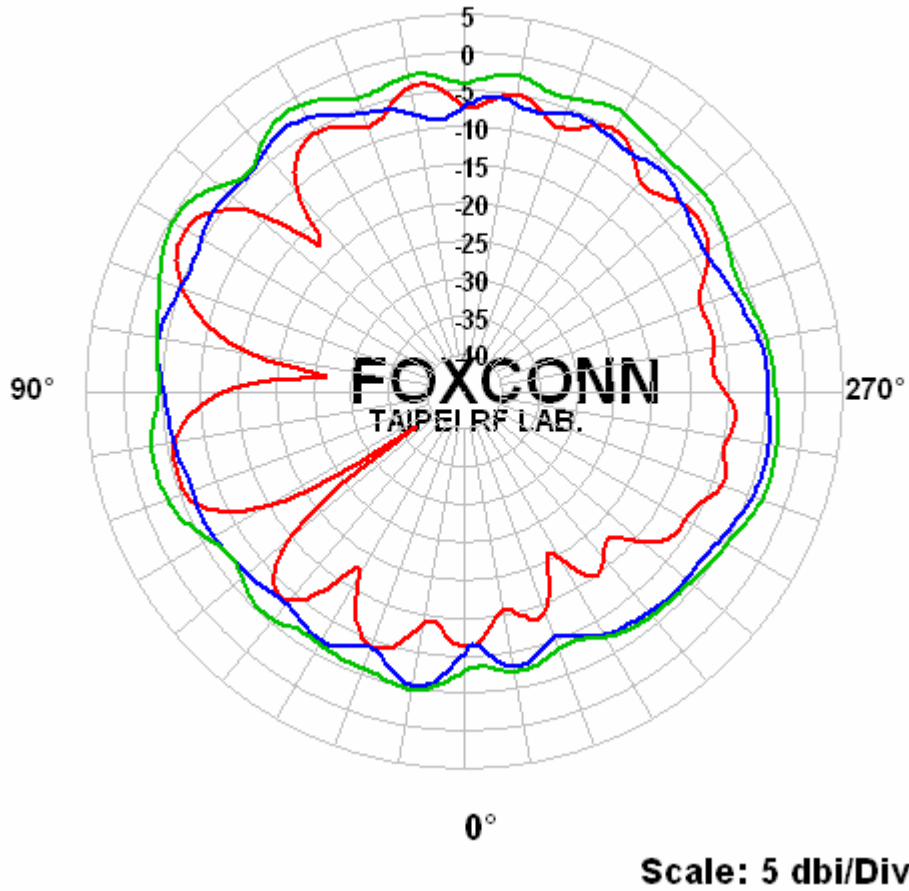

Center Frequency	2450 MHz
Horizontal (dBi) peak	-2.39
Vertical (dBi) peak	-2.84
Horz+Vert (dBi) peak	-0.4

Main antenna: 2500 MHz

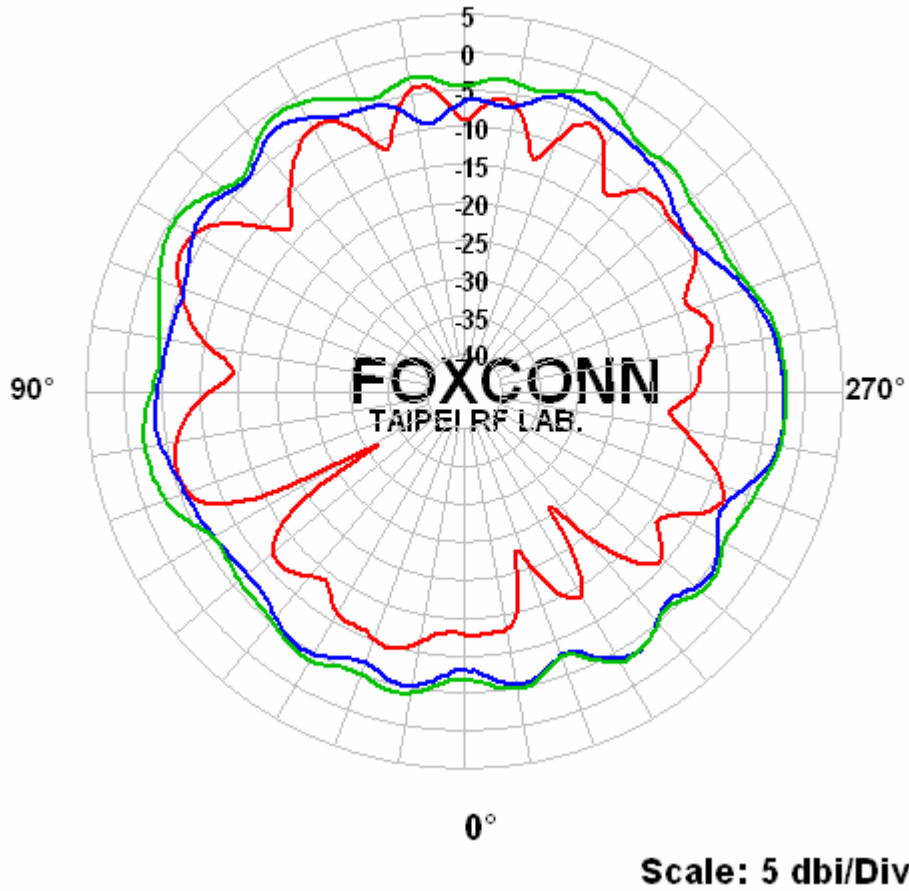

Center Frequency	2500 MHz
Horizontal (dBi) peak	-3.2
Vertical (dBi) peak	-2.17
Horz+Vert (dBi) peak	-0.53

Auxiliary antenna: 2400 MHz

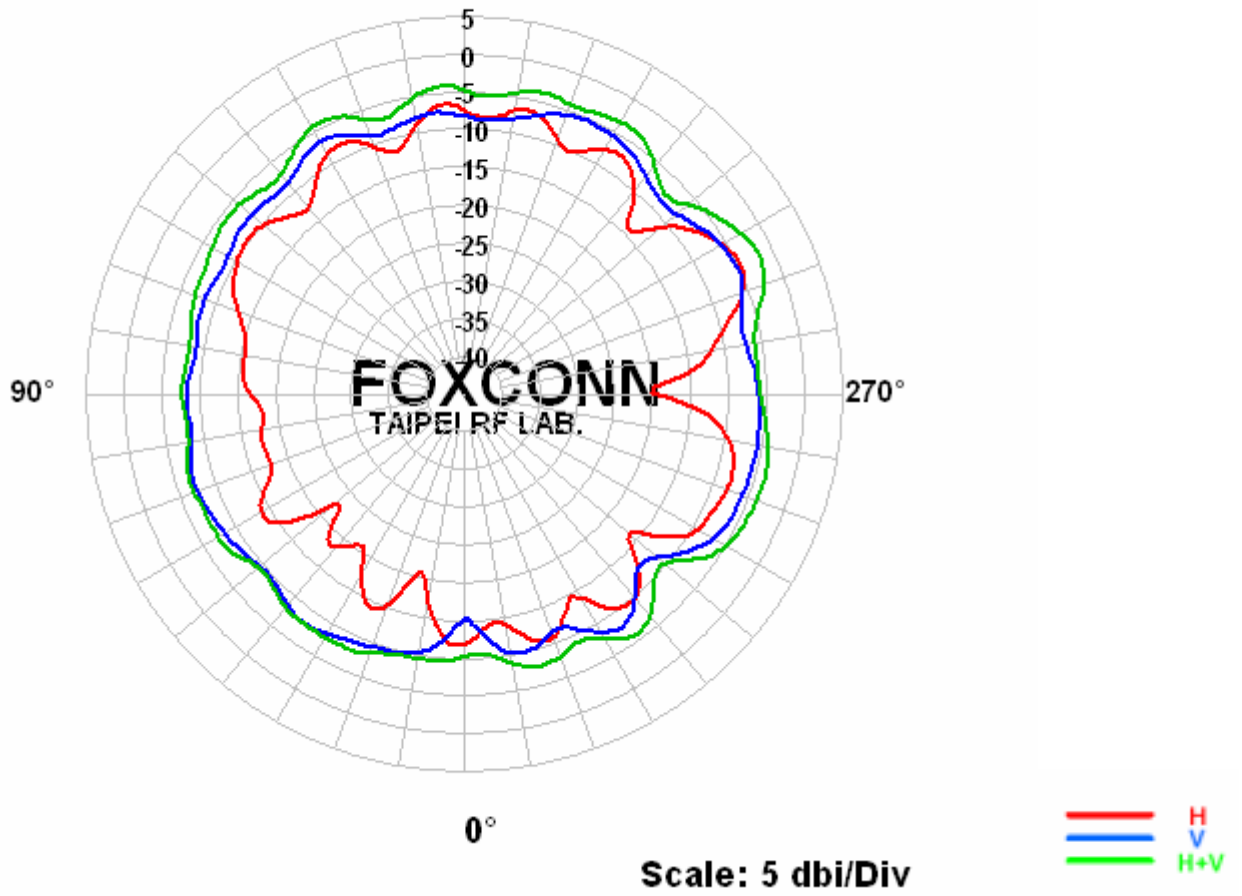

Center Frequency	2400 MHz
Horizontal (dBi) peak	-4.54
Vertical (dBi) peak	-5.16
Horz+Vert (dBi) peak	-1.83

Auxiliary antenna: 2450 MHz

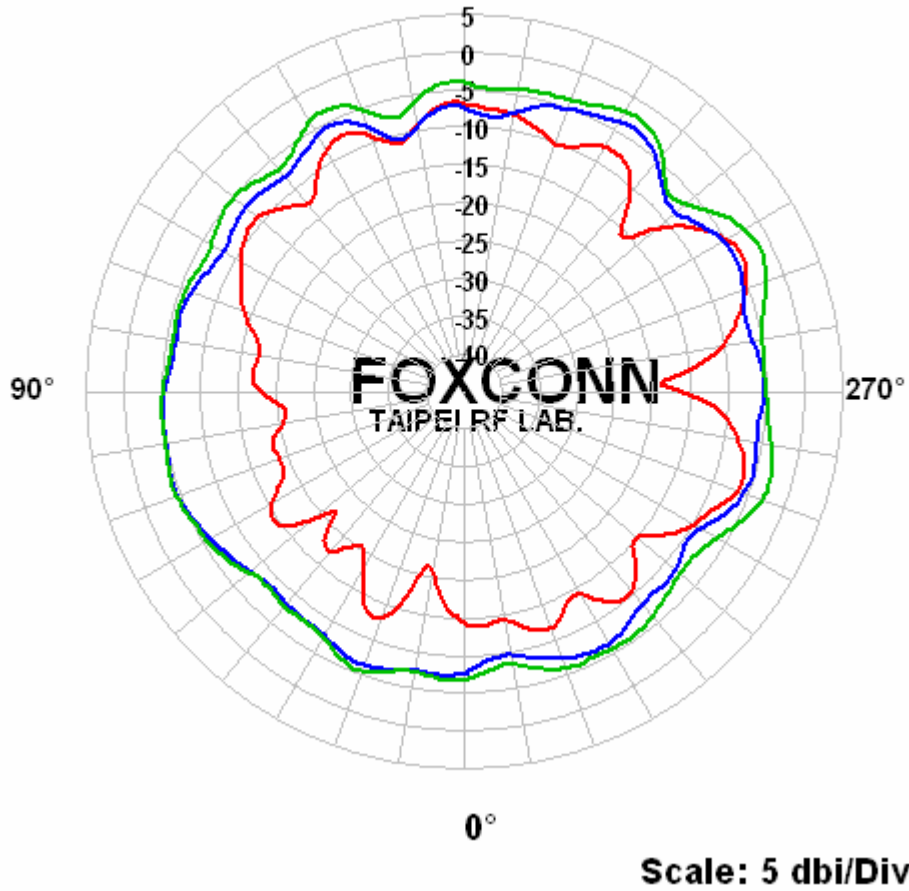

Center Frequency	2450 MHz
Horizontal (dBi) peak	-4.04
Vertical (dBi) peak	-3.61
Horz+Vert (dBi) peak	-1.47

Auxiliary antenna: 2500 MHz

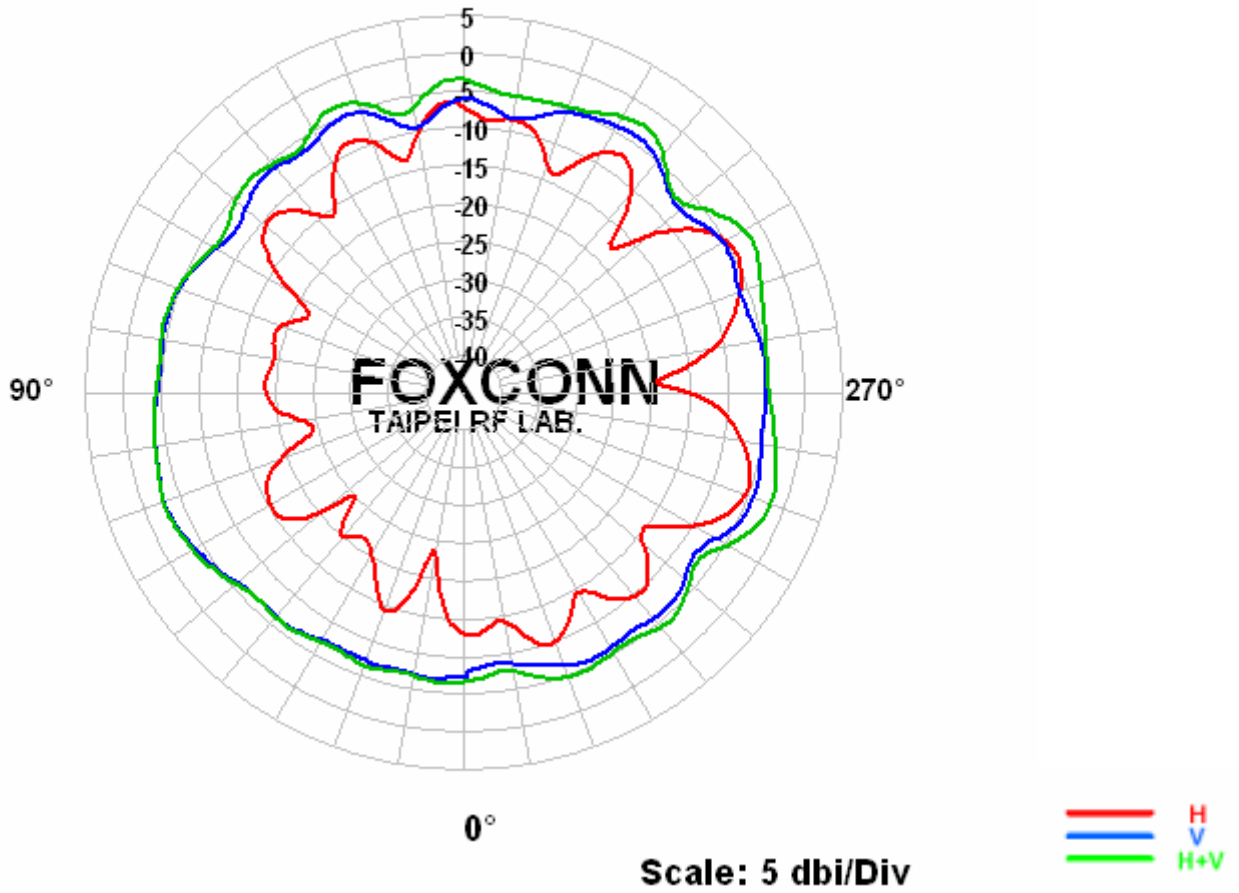

Center Frequency	2500 MHz
Horizontal (dBi) peak	-4.43
Vertical (dBi) peak	-2.85
Horz+Vert (dBi) peak	-1.72

5150-5350 MHz radiation characteristic

Main antenna: 5150 MHz

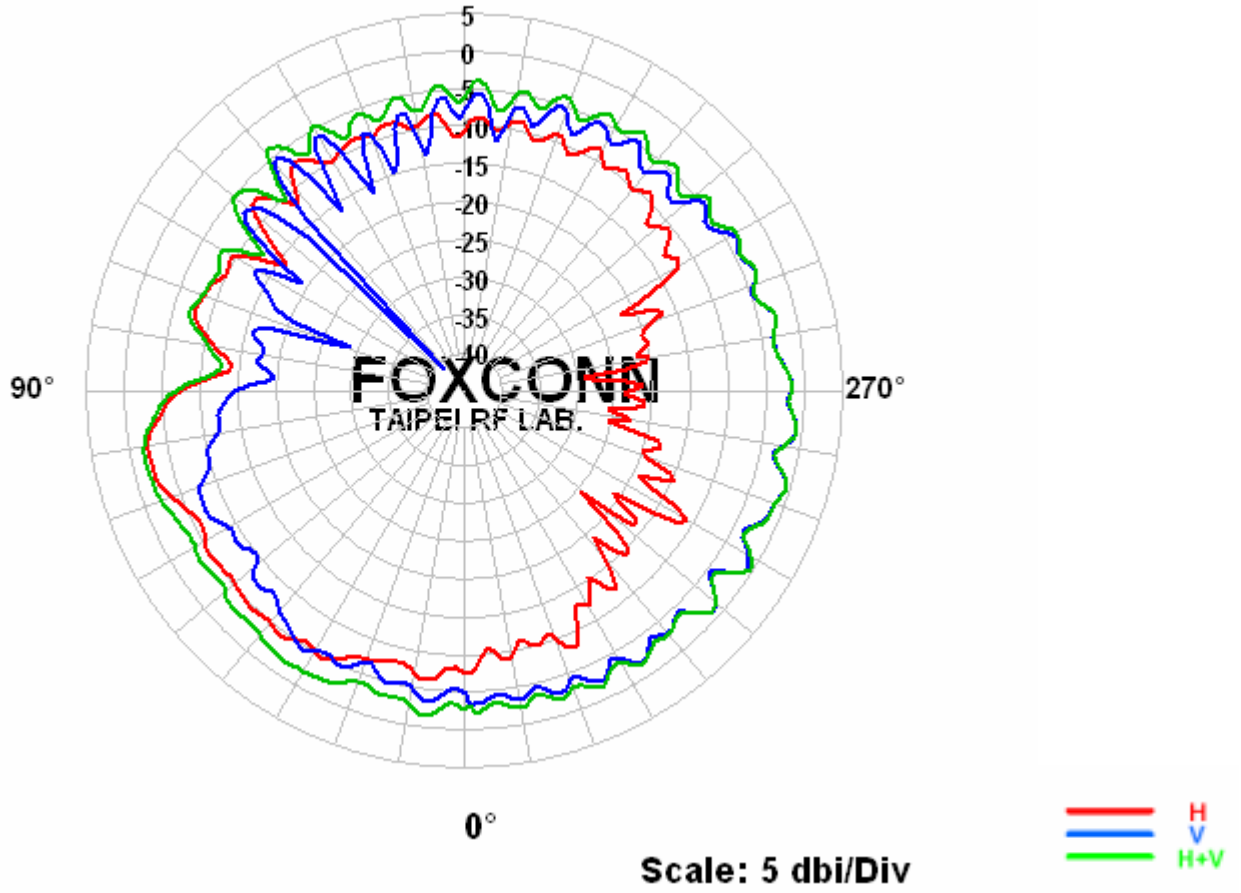

Center Frequency	5150 MHz
Horizontal (dBi) peak	-2.47
Vertical (dBi) peak	-0.55
Horz+Vert (dBi) peak	-0.31

Main antenna: 5250 MHz

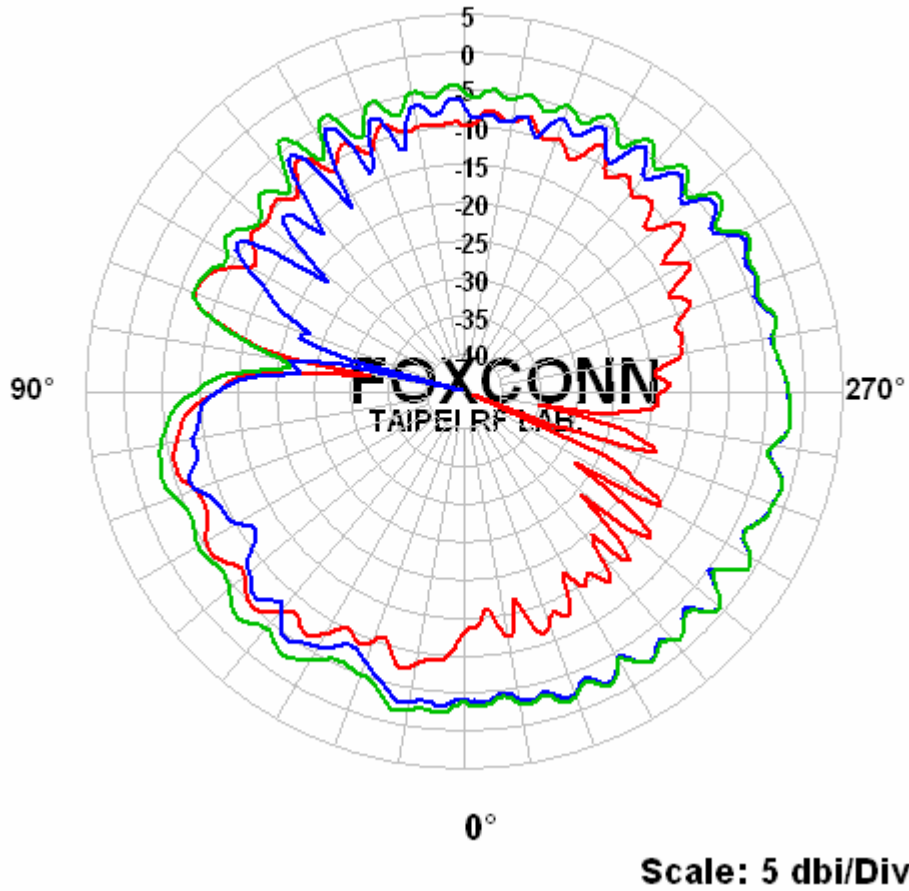

Center Frequency	5250 MHz
Horizontal (dBi) peak	-5.13
Vertical (dBi) peak	-0.61
Horz+Vert (dBi) peak	-0.66

Main antenna: 5350 MHz

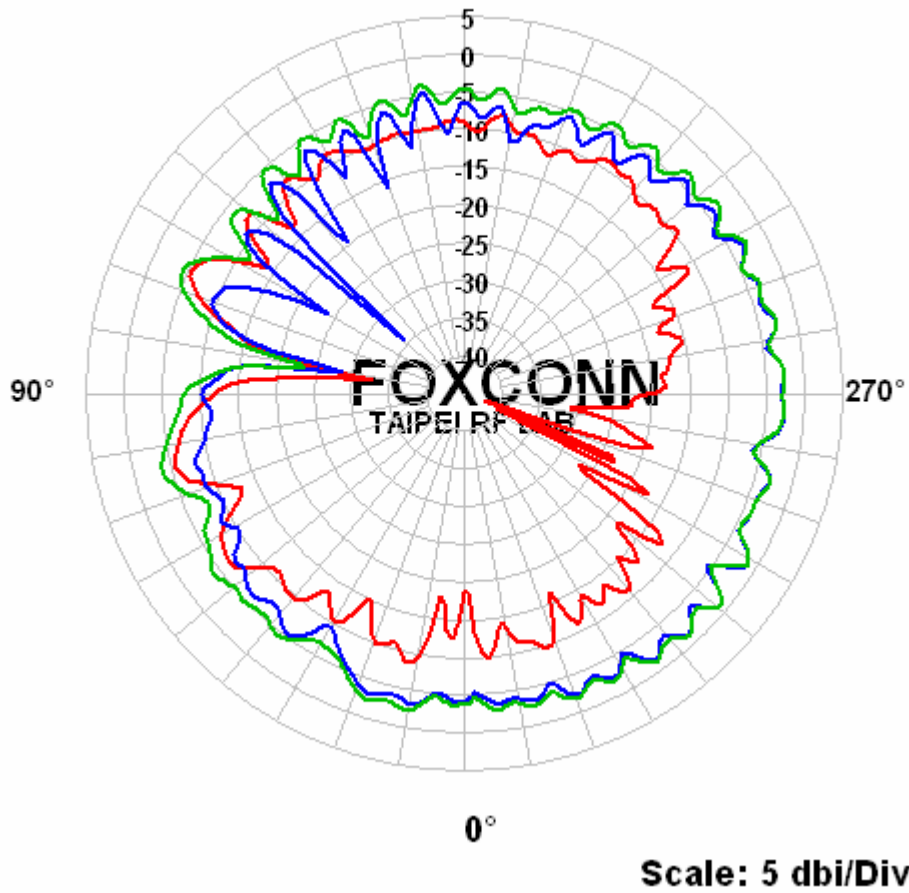

Center Frequency	5350 MHz
Horizontal (dBi) peak	-5.5
Vertical (dBi) peak	-1.09
Horz+Vert (dBi) peak	-1.02

Auxiliary antenna: 5150 MHz

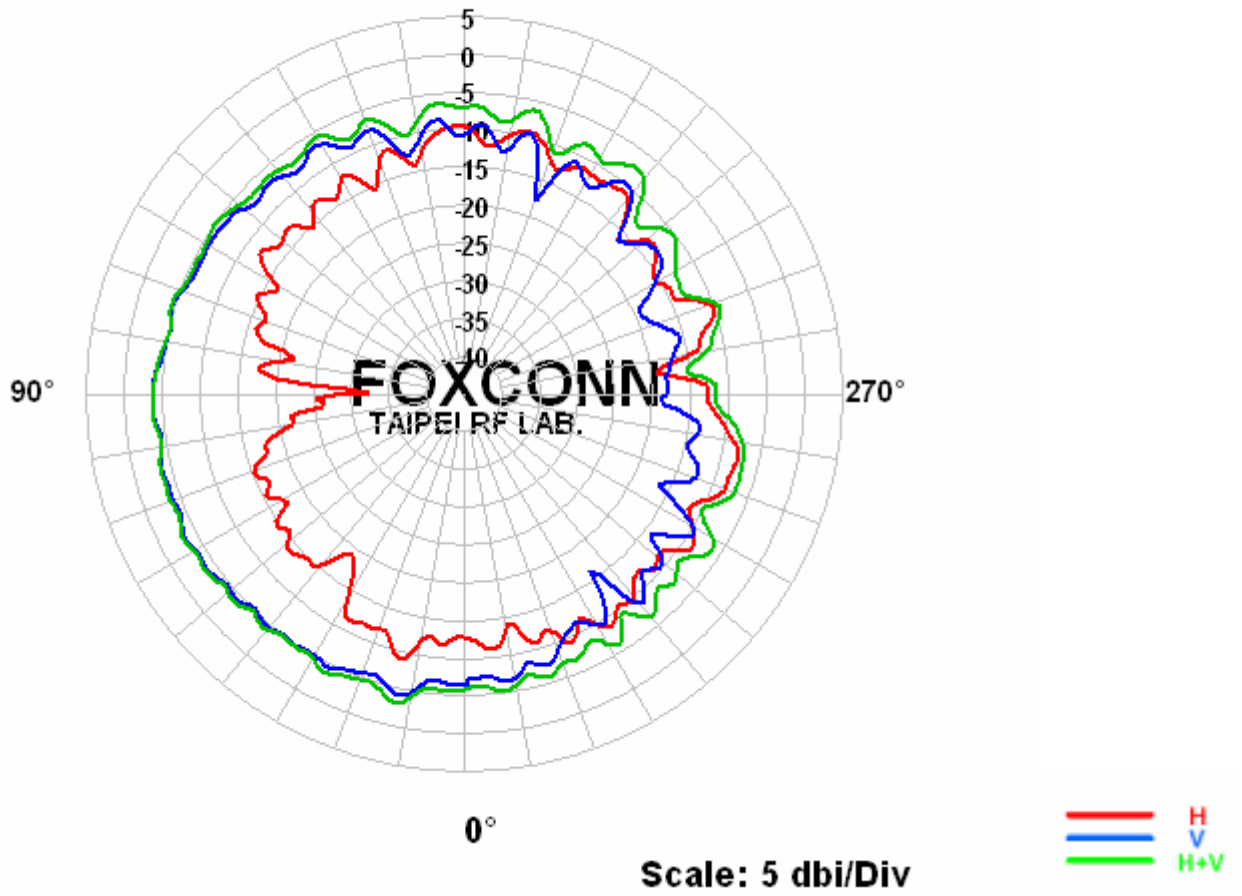

Center Frequency	5150 MHz
Horizontal (dBi) peak	-7.65
Vertical (dBi) peak	-3.39
Horz+Vert (dBi) peak	-3.1

Auxiliary antenna: 5250 MHz

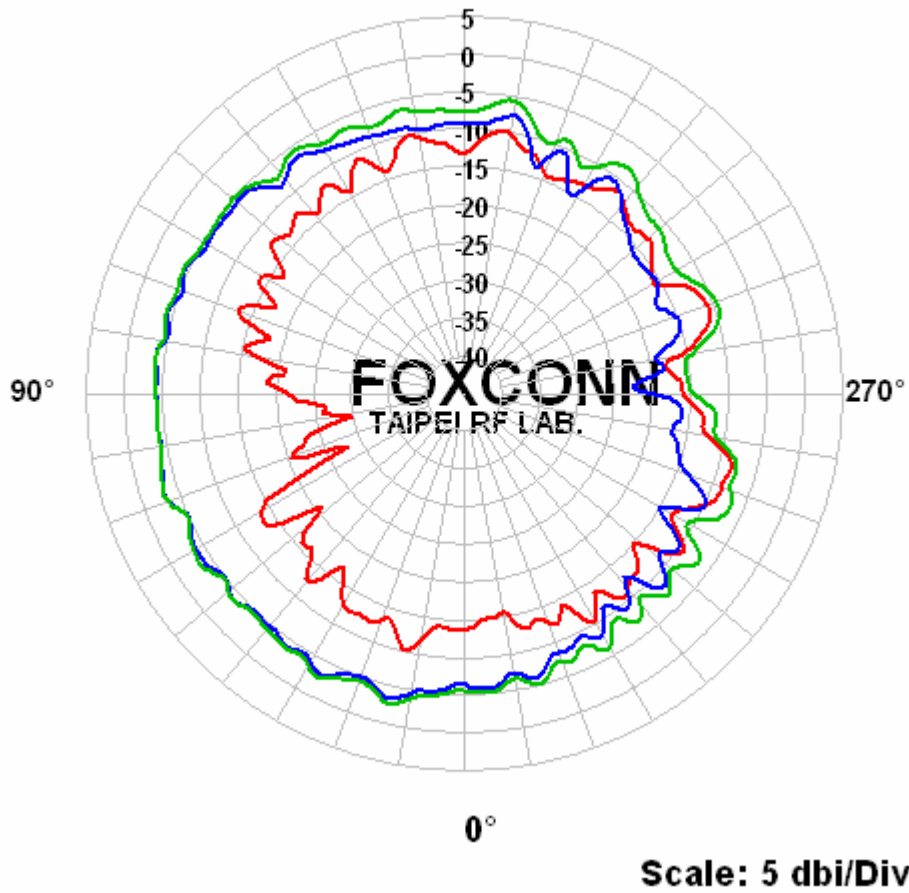

Center Frequency	5250 MHz
Horizontal (dBi) peak	-8.36
Vertical (dBi) peak	-3.15
Horz+Vert (dBi) peak	-2.69

Auxiliary antenna: 5350 MHz

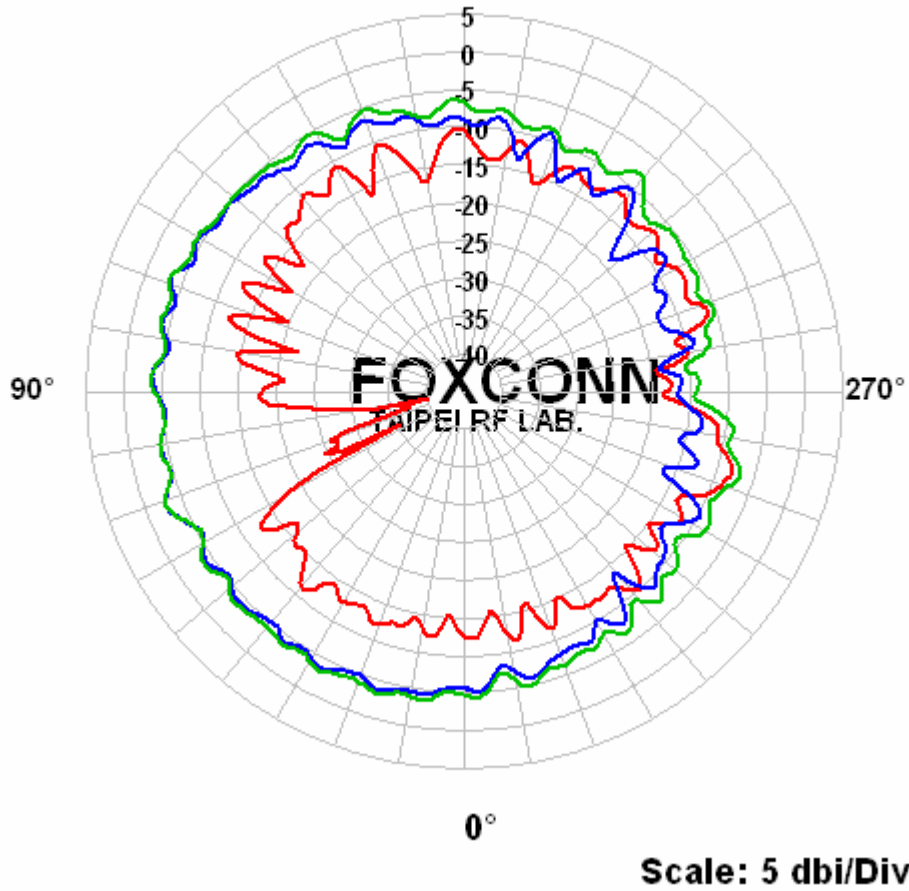

Center Frequency	5350 MHz
Horizontal (dBi) peak	-8
Vertical (dBi) peak	-2.74
Horz+Vert (dBi) peak	-2.72

5725-5875MHz radiation characteristic

Main antenna: 5725 MHz

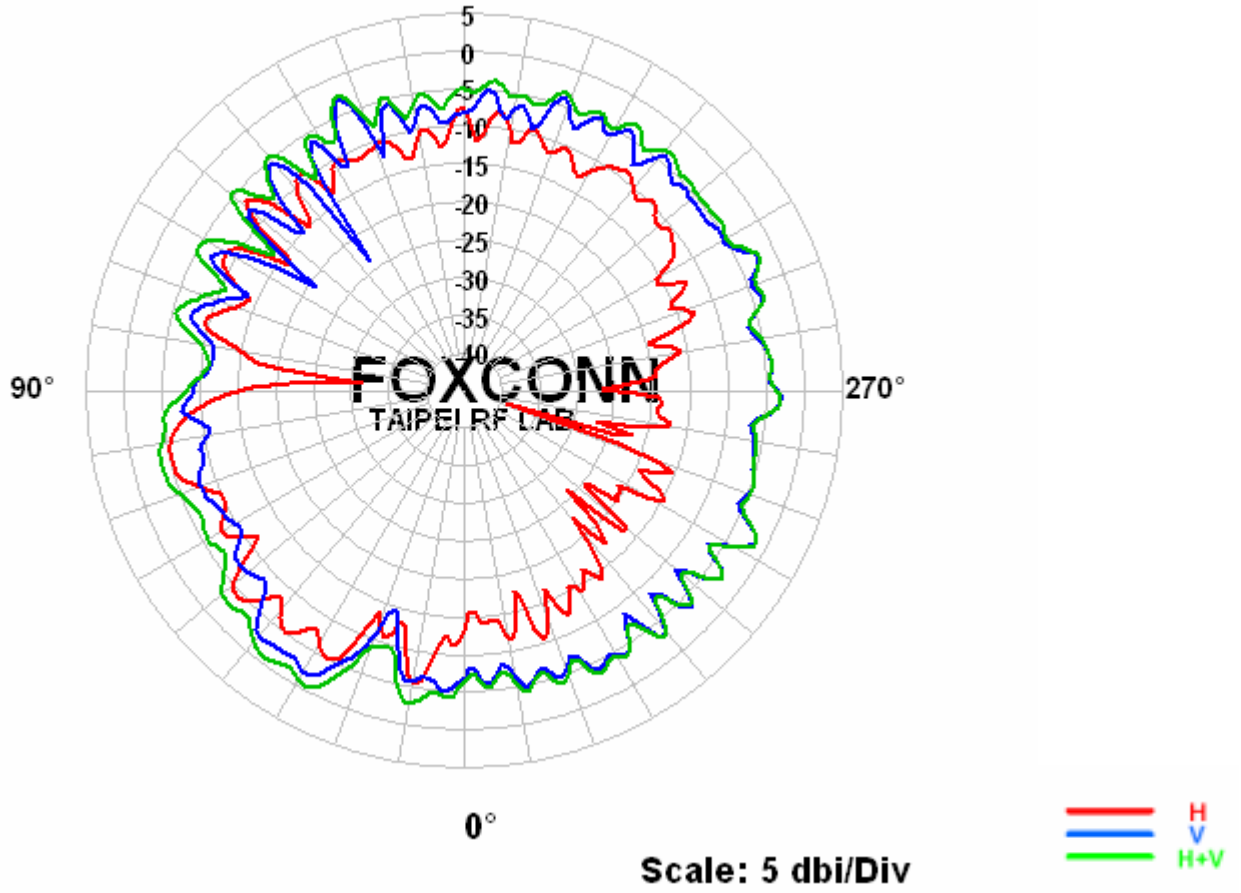

Center Frequency	5725 MHz
Horizontal (dBi) peak	-4.41
Vertical (dBi) peak	-1.56
Horz+Vert (dBi) peak	-0.48

Main antenna: 5800 MHz

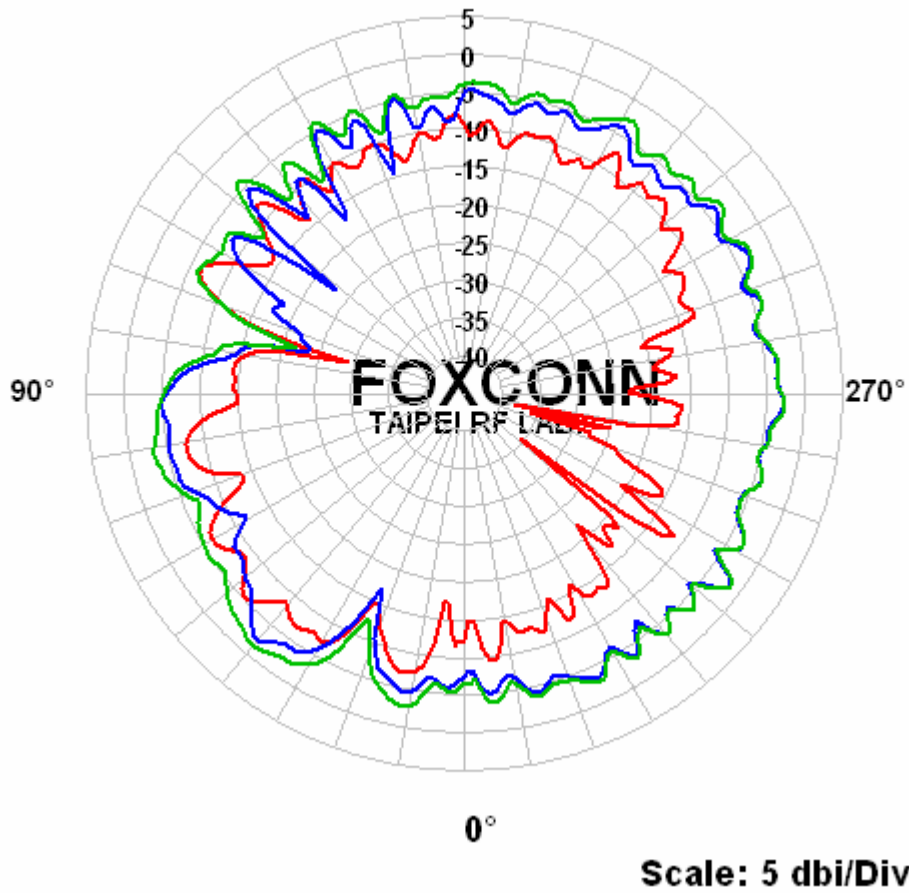

Center Frequency	5800 MHz
Horizontal (dBi) peak	-5.33
Vertical (dBi) peak	-1.42
Horz+Vert (dBi) peak	-1.29

Main antenna: 5875 MHz

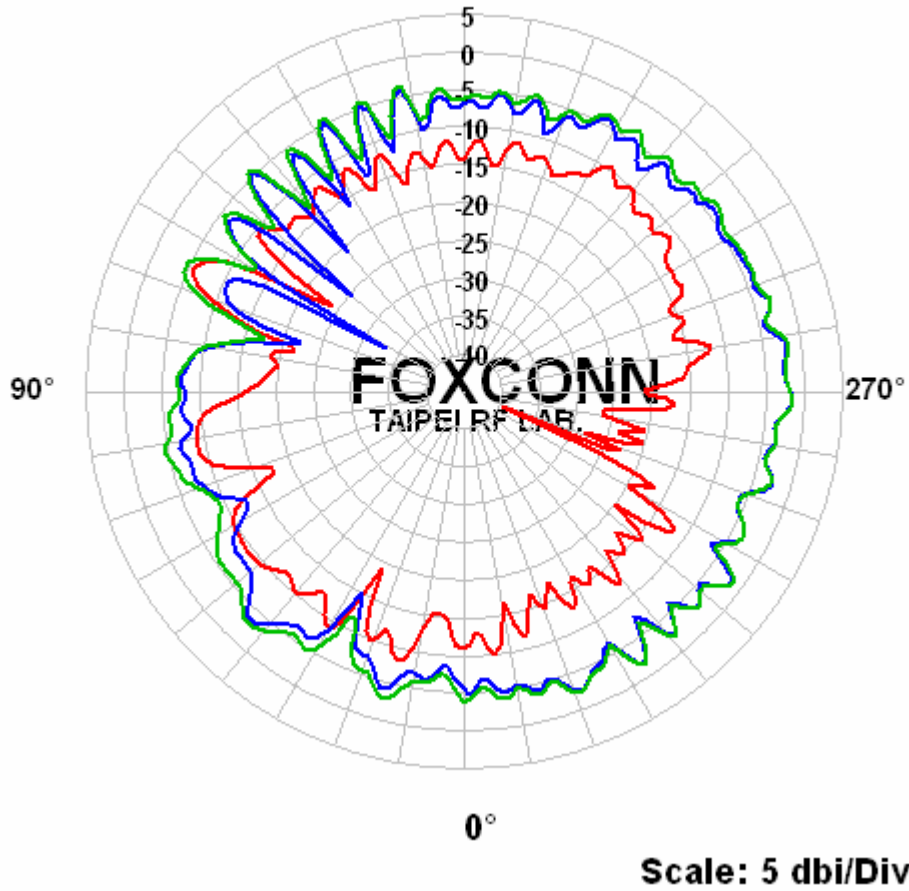

Center Frequency	5875 MHz
Horizontal (dBi) peak	-5.85
Vertical (dBi) peak	-1.53
Horz+Vert (dBi) peak	-1.44

Auxiliary antenna: 5725 MHz

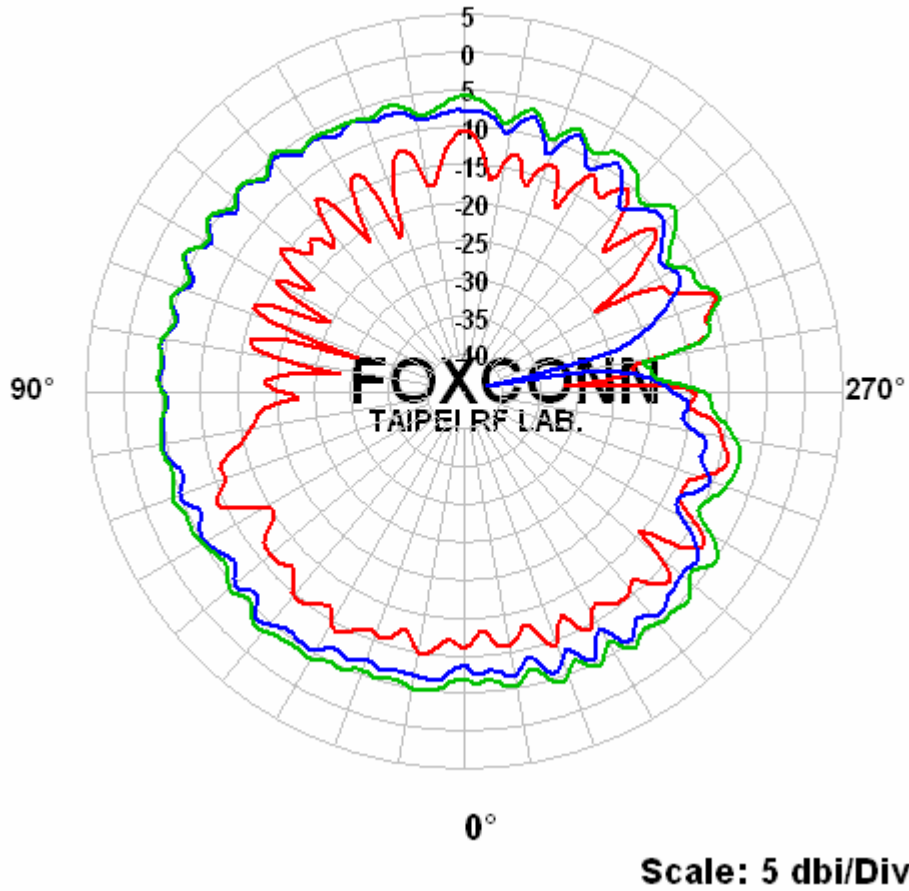

Center Frequency	5725 MHz
Horizontal (dBi) peak	-7.29
Vertical (dBi) peak	-3.72
Horz+Vert (dBi) peak	-3.33

Auxiliary antenna: 5800 MHz

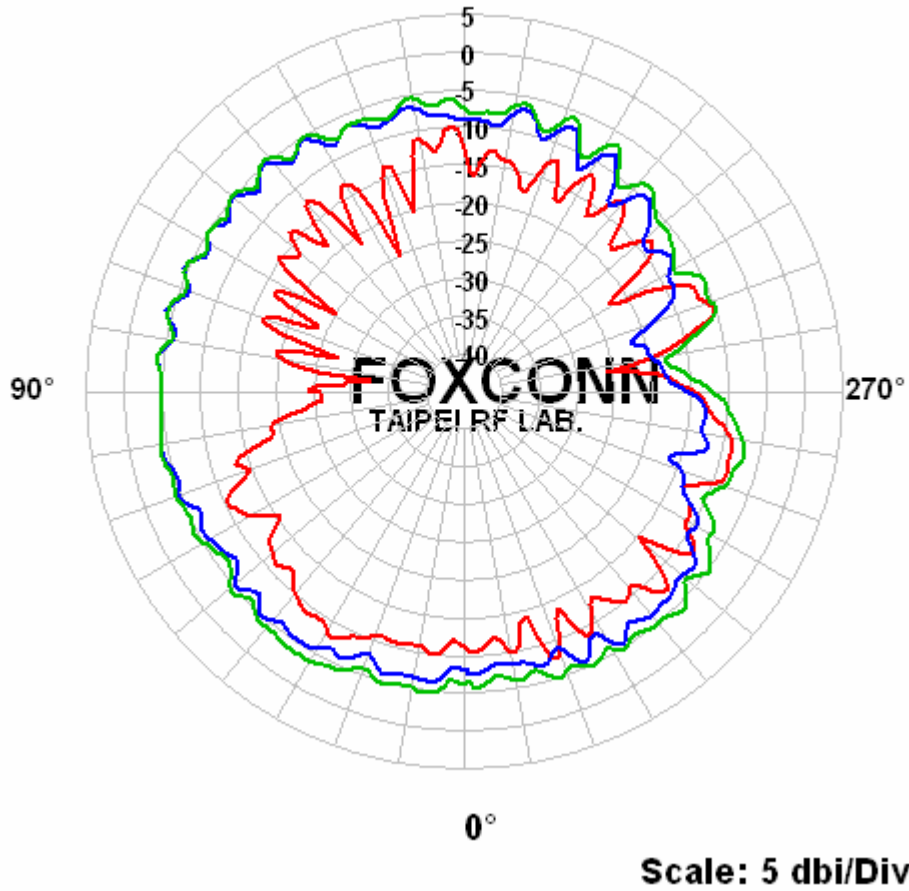

Center Frequency	5800 MHz
Horizontal (dBi) peak	-7.4
Vertical (dBi) peak	-4.19
Horz+Vert (dBi) peak	-3.82

Auxiliary antenna: 5875 MHz

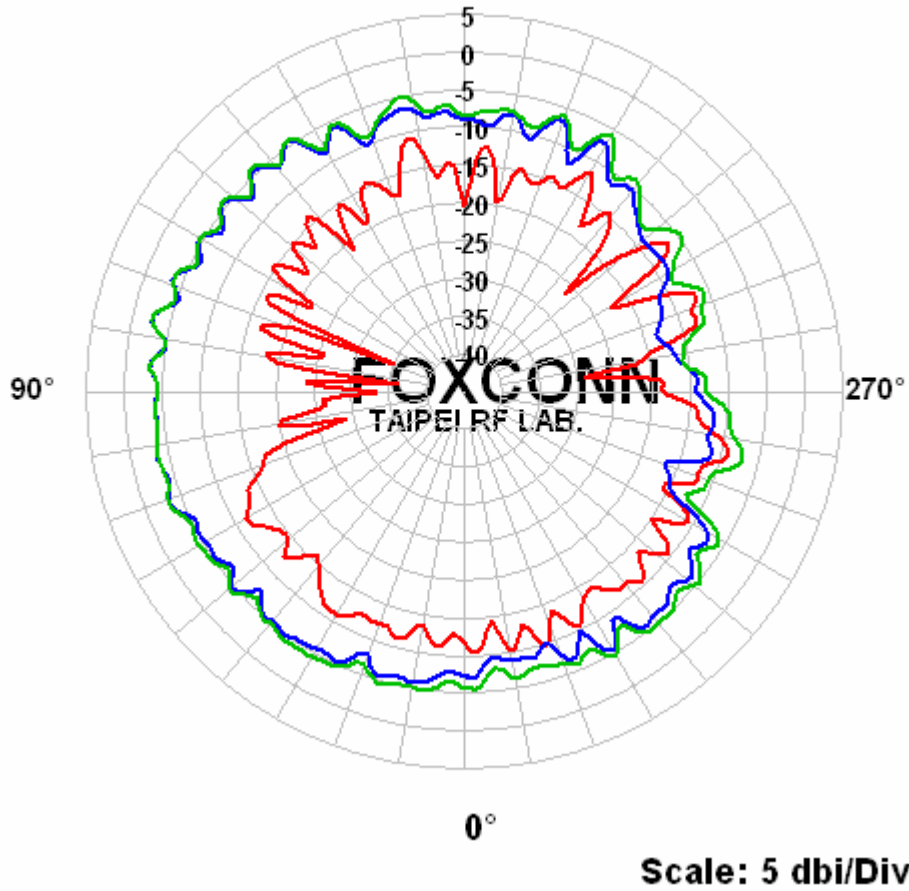

Center Frequency	5875 MHz
Horizontal (dBi) peak	-9.04
Vertical (dBi) peak	-2.7
Horz+Vert (dBi) peak	-2.68

Section 4. Host Platform Information

OEM / ODM Host platform: (XXXXXXX) platform correlated to antenna data
Rating Label Photo:

Module Location Photo: (if Singapore required)

Section 5. Antenna Host Platform Location Information

Include a dimensioned photos or dimensioned drawings of main and auxiliary antenna placements.

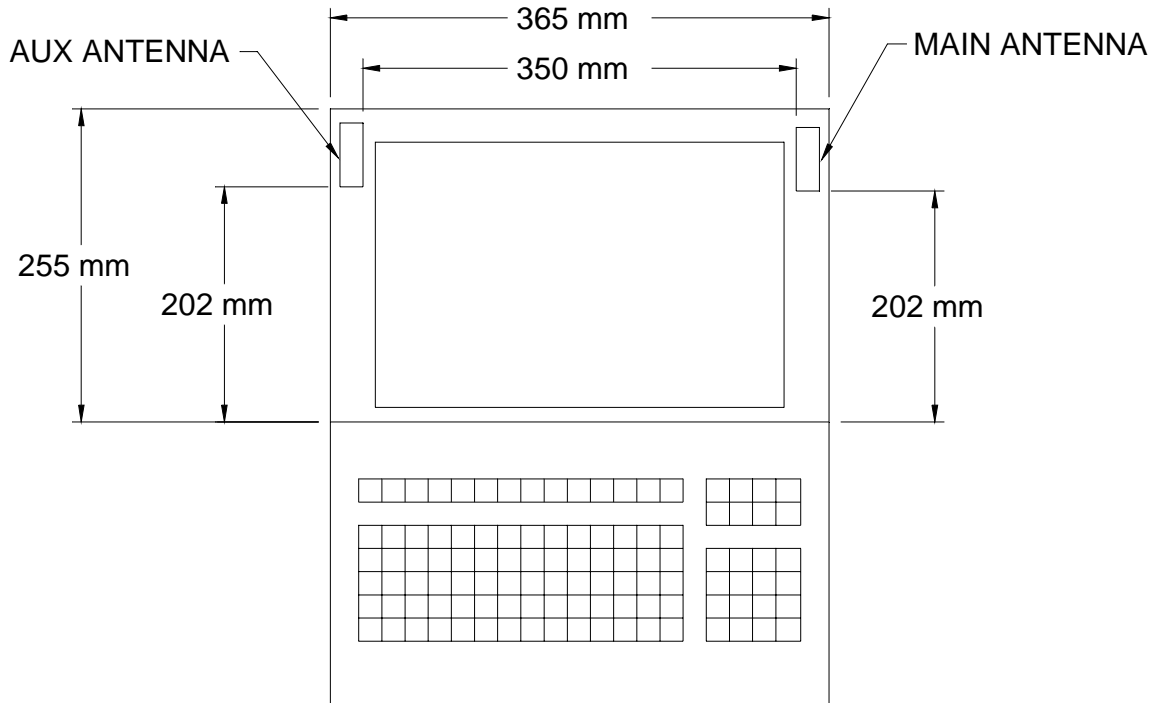

Section 6. Antenna dimensional information for SAR evaluation

Include a dimensioned photos or dimensioned drawings showing the distance (mm) between the transmit (main) antenna and the user (excluding hands, wrist, feet, and ankle)

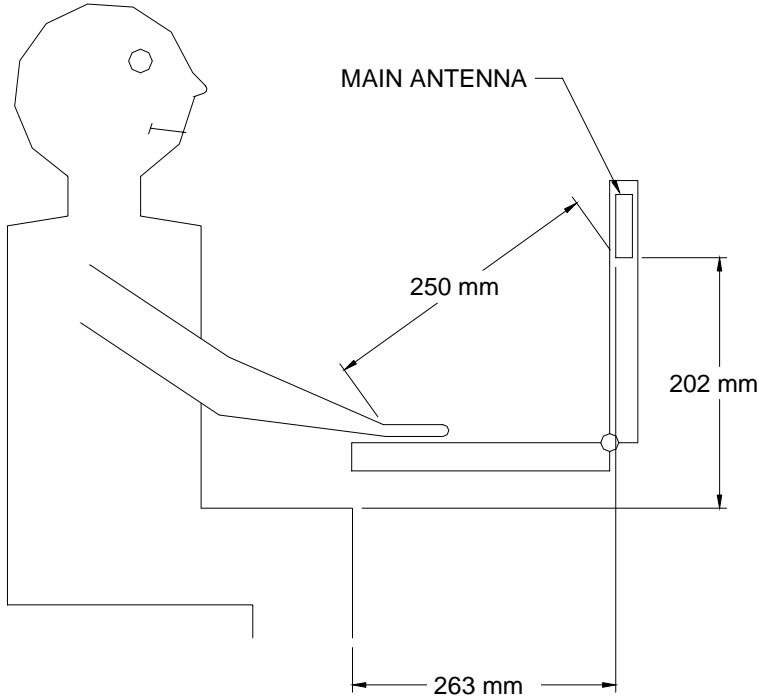

Section 7. Diagram Example of Co-Location Antenna Separation

Indicate distance between WLAN module antennas and Bluetooth/other radio antenna element.

(Note: Due to the evolving rules regarding co-location, each platform will need to be reviewed on a case by case basis)

