

### Antenna Summary (Reversed-F Antenna)

Antenna Type	Reversed-F Antenna
Cable type ( length )	Coax( about 500mm )
P/N	Left : 2576965 Right : 2576957
Gain	MAX : 0.39(dBi) *see Note

\* Note:

1. Included all cable losses.

Antenna Position

Picture:

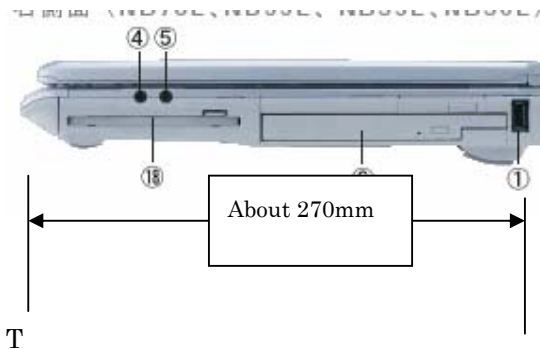





Reverse F type Antenna with Cable & Connector

Product Specification

- 1. The specification of the antenna
  - 1.1 Antenna dimension

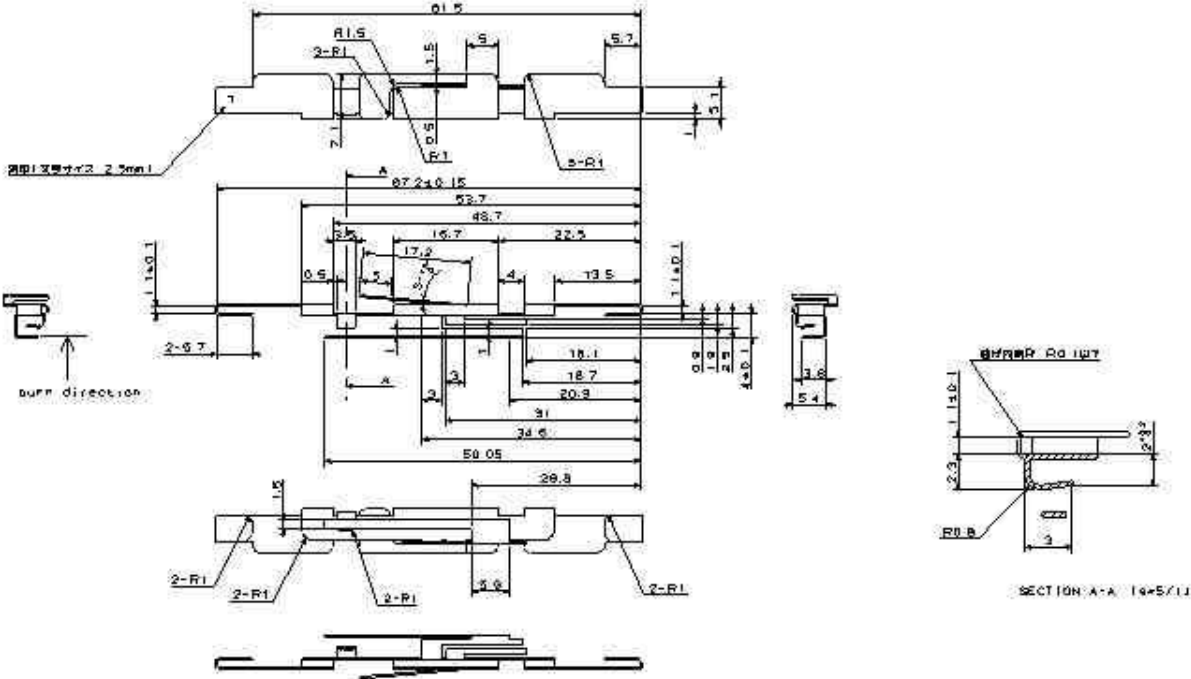

Fig-1 Left side antenna

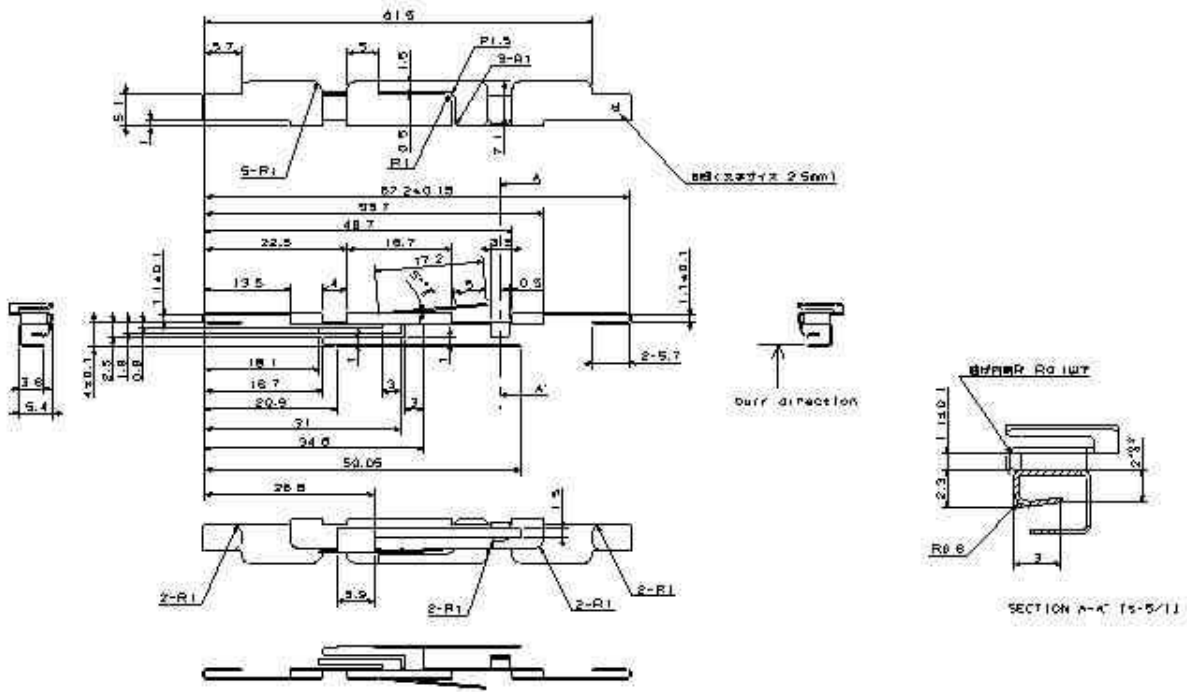

Fig-2 Right side antenna



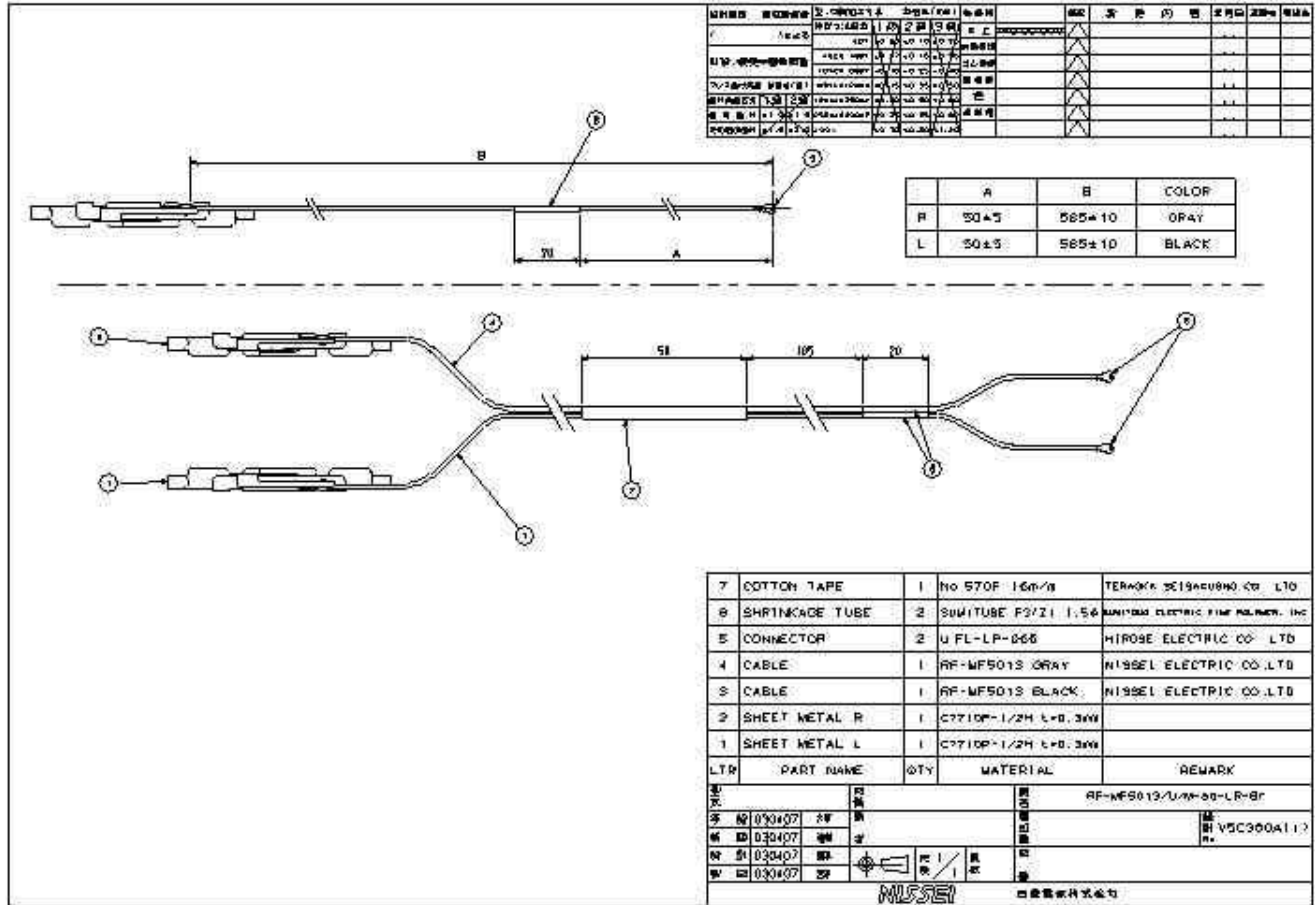

Fig-3 Antenna, Cable and Connector dimension

1.2 The specification of the antenna

Head	Standard value	Remarks	
Antenna Type	Reverse F type Antenna		
Weight	9.5 g	Total weight of L and R side	
At 2.4-2.5GHz	V.S.W.R	3.0 max The shake of a characteristic curve and the abnormalities in a point should not be within measurement frequency.	Network Analyzer
	Band Wide Center Freq.	Nominal 2.45GHz	Network Analyzer
	Band Wide	More than 120MHz	Network Analyzer
	Peek Gain	1.5dBi max	Standard Antenna Substitution

### 1.3 The specification of the cable

Type	Inner Conductor			Dielectric Core		Outer Conductor		Jacket	
	Const.	Mater.	Dia.	Mater.	Dia.	Structure	Dia.	Mater.	Dia.
RF-MF5013	7/0.08	SA	0.24	FEP	0.66	TA Double Braid	1.12	FEP	1.32

\* SA: Silver-plated soft annealed copper wire

\* TA: Tin-plated soft annealed copper wire

\* Connector: U.FL-LP-066 (HRS)

### 1.4 Processed-goods characteristic

Head	Unit	Standard value
Temperature range of operation	°C	0~60
Humidity range of operation	%	20~80
Preservation temperature range	°C	-20~70
Preservation humidity range	%	5~95

## 2. The method of measurement

### Standard Antenna Substitution

The measurement frequency: 2.40GHz, 2.45GHz, and 2.50GHz

The direction of the measurement: X-Y (H), X-Y (V), Y-Z (H), Y-Z (V), Z-X (H), and Z-X (V)

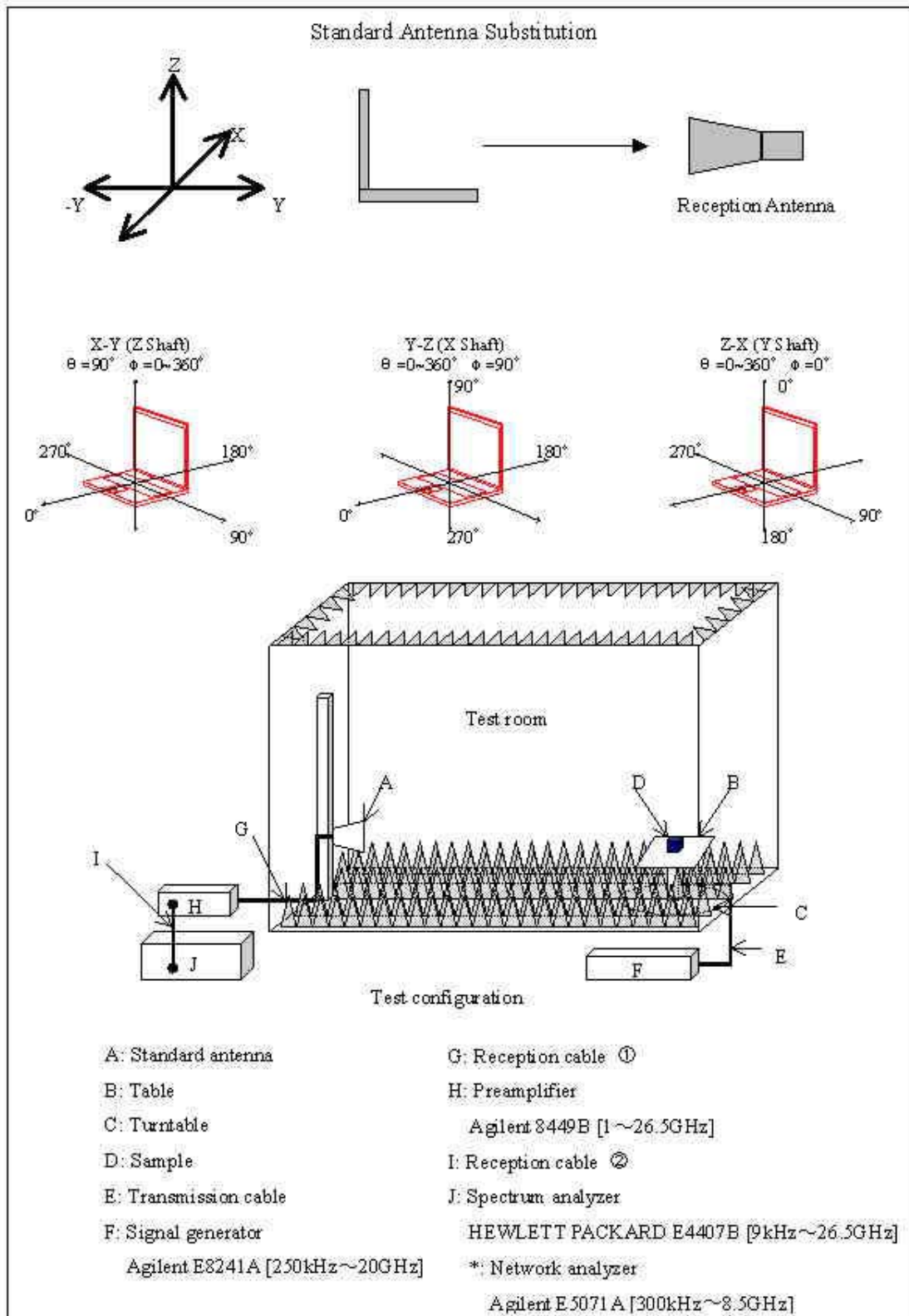

Fig-4 Test configuration

**NISSEI ELECTRIC CO.,LTD.**

HEAD OFFICE 1509 Okubo-cho Hamamatsu-shi Shizuoka-ken 432-8006  
TEL 81-53-485-4705 / FAX 81-532-485-5444



3. The measurement result

3.1 V.S.W.R.

at 2.0~3.0GHz

	VSWR			Band Wide [MHz]	BW Center Freq [GHz]	Min. VSWR	
	2.40GHz	2.45GHz	2.50GHz			Freq[GHz]	VSWR
VSWR with cable	1.199	1.434	1.598	285	2.383	2.380	1.030
VSWR without cable	1.181	1.329	1.506	520	2.375	2.360	1.119

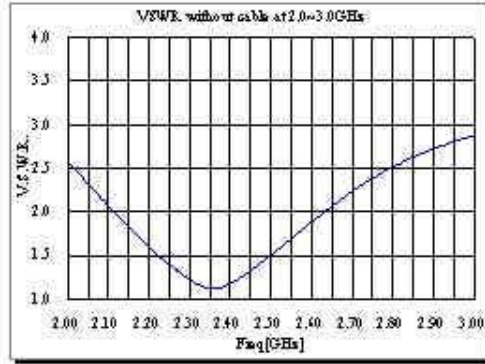
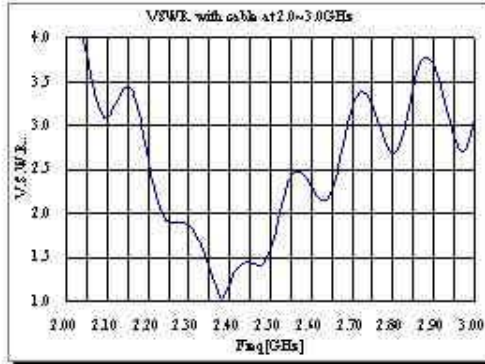

Fig-5 Left side antenna

at 2.0~3.0GHz

	VSWR			Band Wide [MHz]	BW Center Freq [GHz]	Min. VSWR	
	2.40GHz	2.45GHz	2.50GHz			Freq[GHz]	VSWR
VSWR with cable	1.264	1.437	1.534	225	2.418	2.385	1.213
VSWR without cable	1.263	1.348	1.493	490	2.395	2.385	1.257

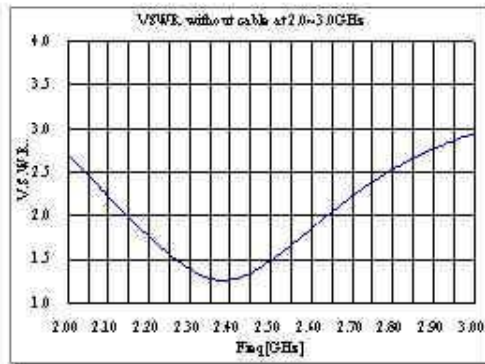
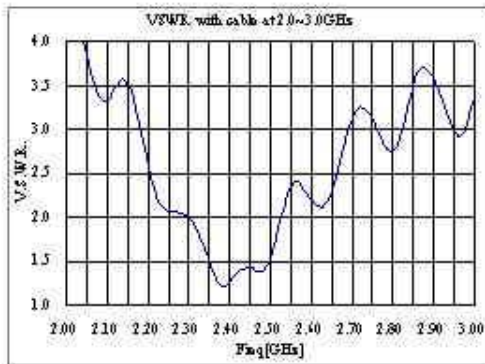

Fig-6 Right side antenna

### 3.2 Antenna Radiation Pattern

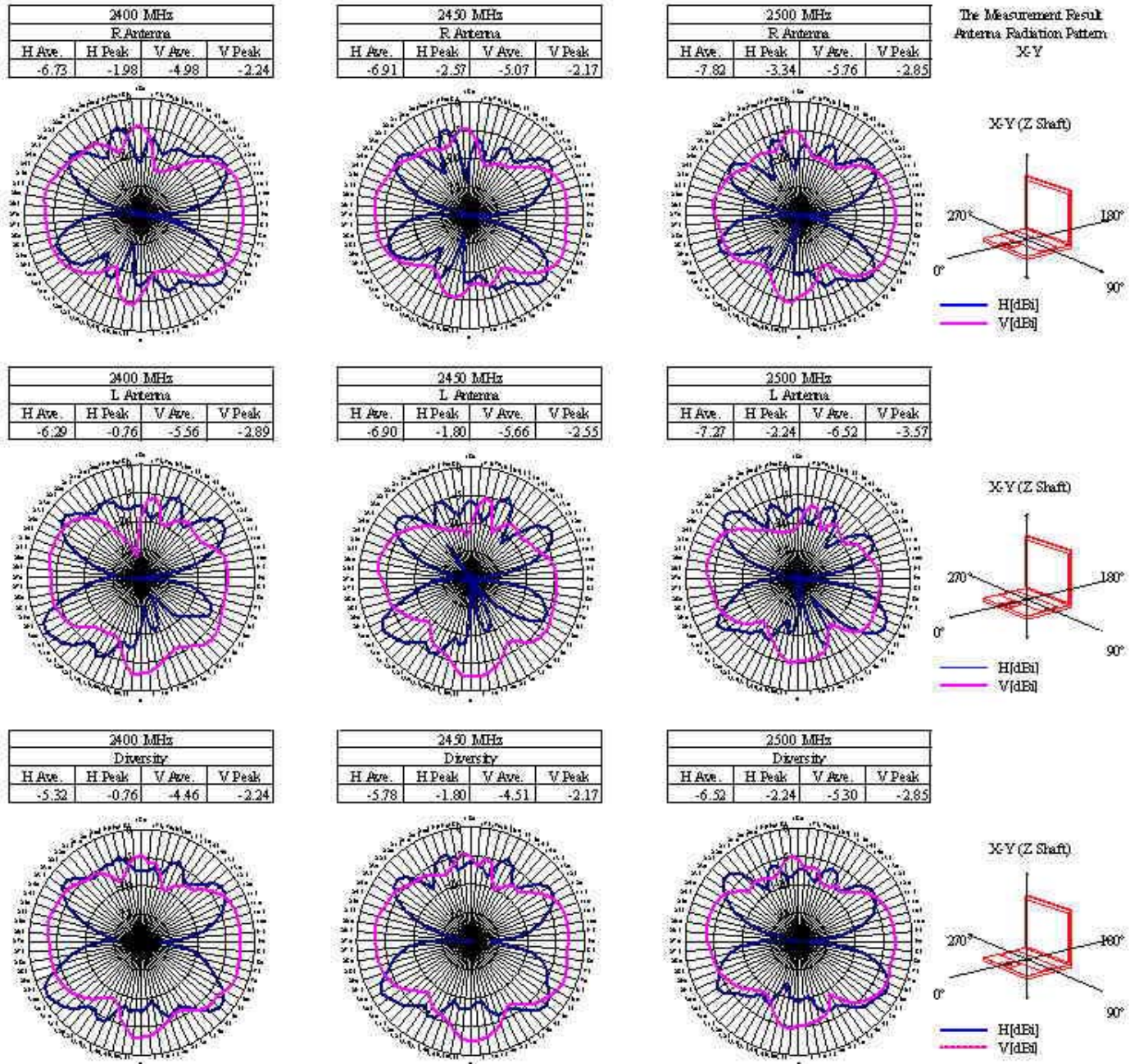

Fig-7 Antenna Radiation Pattern (X-Y)



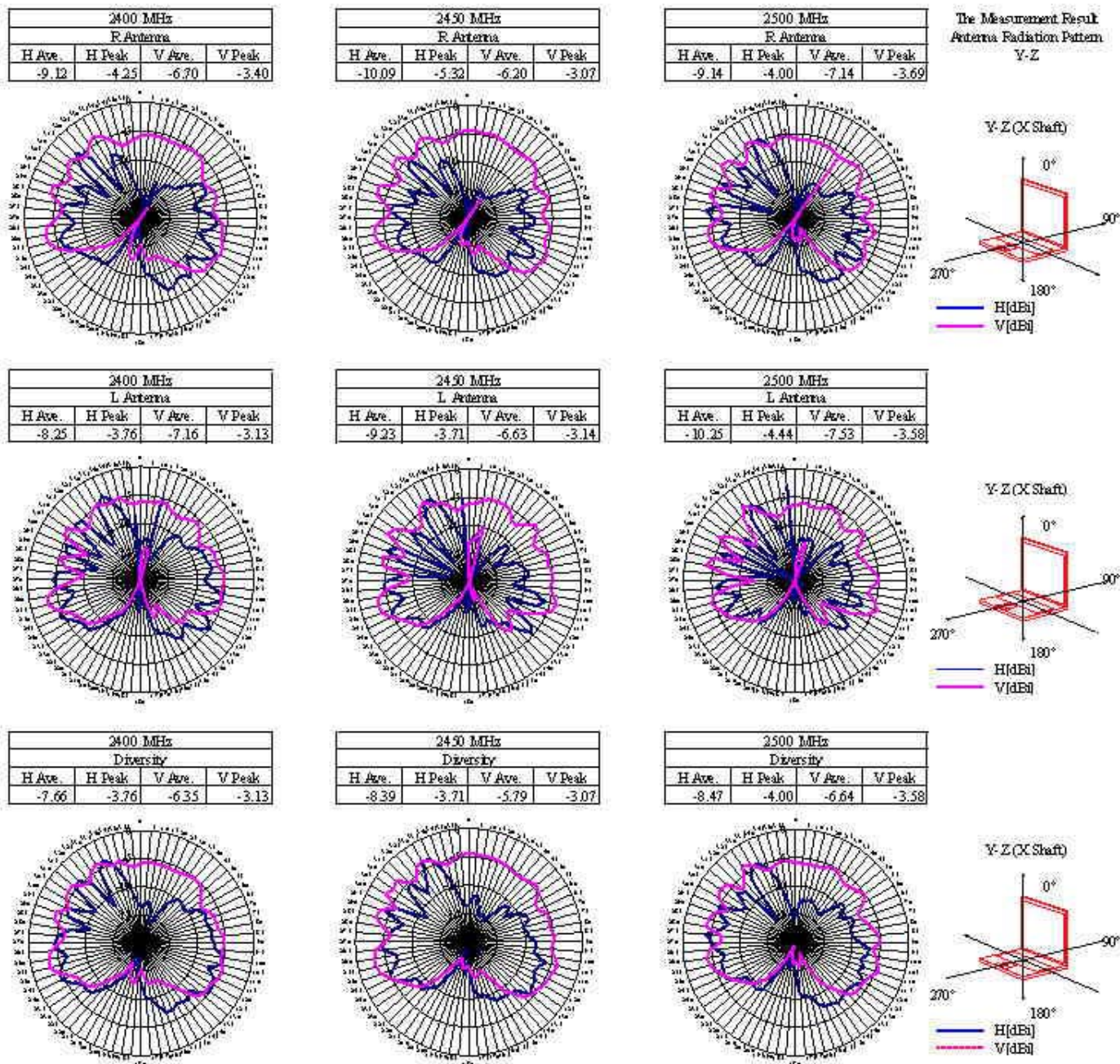

Fig-8 Antenna Radiation Pattern (Y-Z)



2400 MHz			
R Antenna			
H Ave.	H Peak	V Ave.	V Peak
-4.54	0.39	-15.06	-8.64

2490 MHz			
R Antenna			
H Ave.	H Peak	V Ave.	V Peak
-4.68	0.05	-14.76	-7.86

2500 MHz			
R Antenna			
H Ave.	H Peak	V Ave.	V Peak
-5.39	0.25	-15.24	-7.64

The Measurement Result  
Antenna Radiation Pattern  
Z-X

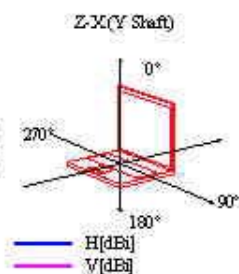
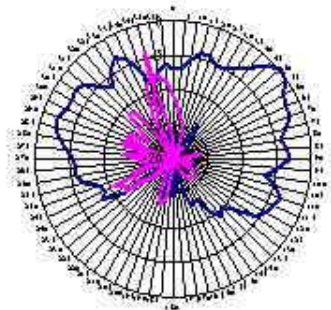
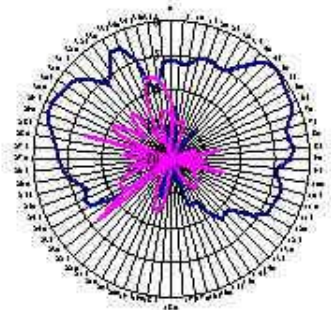
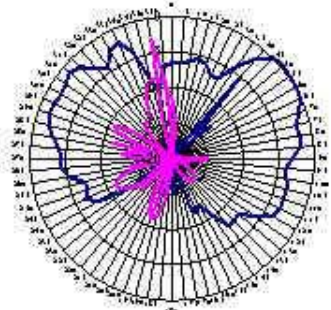

2400 MHz			
L Antenna			
H Ave.	H Peak	V Ave.	V Peak
-4.88	-0.41	-15.58	-10.27

2490 MHz			
L Antenna			
H Ave.	H Peak	V Ave.	V Peak
-5.00	-0.38	-15.29	-8.67

2500 MHz			
L Antenna			
H Ave.	H Peak	V Ave.	V Peak
-5.59	0.18	-16.26	-9.56

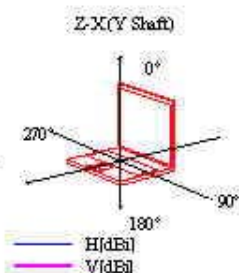
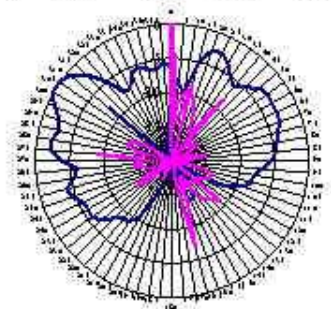
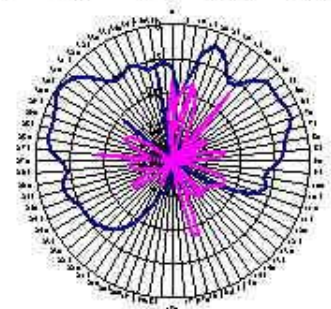
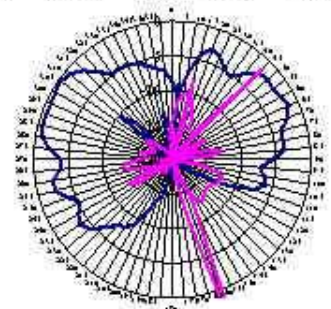

2400 MHz			
Diversity			
H Ave.	H Peak	V Ave.	V Peak
-3.72	0.39	-13.41	-8.64

2490 MHz			
Diversity			
H Ave.	H Peak	V Ave.	V Peak
-4.03	0.05	-13.24	-7.86

2500 MHz			
Diversity			
H Ave.	H Peak	V Ave.	V Peak
-4.44	0.25	-13.86	-7.64

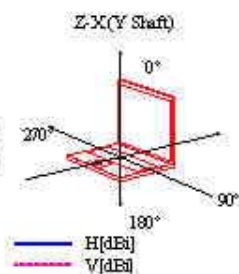
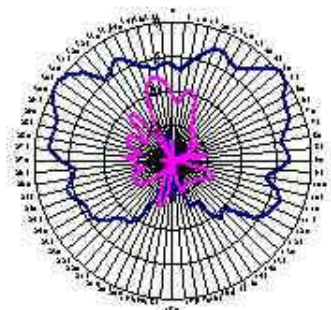
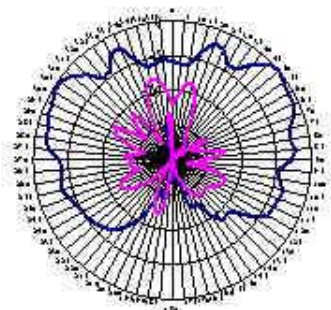
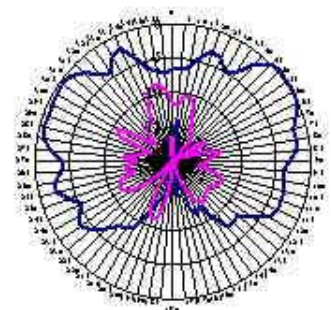

Fig-9 Antenna Radiation Pattern (Z-X)

**NISSEI ELECTRIC CO.,LTD.**

HEAD OFFICE 1509 Okubo-cho Hamamatsu-shi Shizuoka-ken 432-8006  
TEL 81-53-485-4705 / FAX 81-532-485-5444