

TEST REPORT

EUT Description	WLAN and BT, 2x2 PCIe M.2 2230 adapter card
Brand Name	Intel®
Model Name	BE201NGW
FCC/IC ID	PD9BE201NG ; 1000M-BE201NG
Date of Test Start/End	2023-11-12 /2023-12-29
Features	2x2 WiFi - Bluetooth® (see section 5)

Applicant	Intel Corporation SAS
Address	425 Rue de Goa – Le Cargo B6 – 06600 Antibes, FRANCE
Contact Person	Benjamin Lavenant
Telephone/Fax/Email	Benjamin.lavenant@intel.com

Reference Standards	FCC CFR Title 47 Part 15 E RSS-247 issue 3, RSS-Gen A1 issue 5 - A1 (see section 1)
---------------------	---

Test Report identification	231109-03.TR09
Revision Control	Rev. 00 This test report revision replaces any previous test report revision (see section 0)

The test results relate only to the samples tested.
Reference to accreditation shall be used only by full reproduction of test report.

Issued by

Reviewed by

Cedric REQUIN
(Test Engineer Lead)

Zayd OUACHICHA
(Technical Manager)

Intel Corporation S.A.S – WRF Lab
425 rue de Goa – Le Cargo B6 - 06600, Antibes, France
Tel. +33493001400 / Fax/be +33493001401

Table of Contents

1. Standards, reference documents and applicable test methods	3
2. General conditions, competences and guarantees	3
3. Environmental Conditions	3
4. Test samples	4
5. EUT Features	5
6. Remarks and comments	5
7. Test Verdicts summary	6
7.1. 802.11 A/N/AC/AX/BE – U-NII-2C	6
8. Document Revision History	6
Annex A. Test & System Description	7
A.1 MEASUREMENT SYSTEM	7
A.2 TEST EQUIPMENT LIST	9
A.3 MEASUREMENT UNCERTAINTY EVALUATION	11
Annex B. Test Results U-NII-2C	12
B.1 TEST CONDITIONS	12
B.2 TEST RESULTS TABLES	13
B.2.1 26dB & 99% Bandwidth	13
B.2.2 Power Limits. Maximum Output power & Maximum power spectral Density	17
B.2.3 Undesirable emission limits : out of band (Conducted)	29
B.2.4 Radiated spurious emission	30
B.3 TEST RESULTS SCREENSHOTS	53
B.3.1 26dB Bandwidth	53
B.3.2 99% Bandwidth	55
B.3.3 Maximum Output Power & Maximum power spectral Density	57
B.3.4 Undesirable emission limits : out of band (Conducted)	59
Annex C. Photographs	77
C.1 TEST SETUP	77
C.2 TEST SAMPLE	79

1. Standards, reference documents and applicable test methods

FCC	<ol style="list-style-type: none"> 1. FCC Title 47 CFR part 15 – Subpart E – Unlicensed National Information Infrastructure Devices. 2021-10-01 Edition 2. FCC Title 47 CFR part 15 - Subpart C – §15.209 Radiated emission limits; general requirements. 2021-10-01 Edition 3. FCC OET KDB 789033 D02 v02r01 - General U-NII Test Procedures New Rules – Guidelines for compliance testing of Unlicensed National Information Infrastructure (U-NII) Devices (Part 15, Subpart E) 4. FCC OET KDB 662911 D01 v02r01 - Emissions Testing of Transmitters with Multiple Outputs in the Same Band. 5. ANSI C63.10-2013 American National Standard of Procedures for Compliance Testing of Unlicensed Wireless Devices.
ISED	<ol style="list-style-type: none"> 1. RSS-Gen Issue 5 Amendment 1 - General Requirements for Compliance of Radio Apparatus. 2. RSS-247 Issue 3 - Digital Transmission Systems (DTSs), Frequency Hopping Systems (FHSs) and License-Exempt Local Area Network (LE-LAN) Devices. 3. FCC OET KDB 789033 D02 v02r01 - General U-NII Test Procedures New Rules – Guidelines for compliance testing of Unlicensed National Information Infrastructure (U-NII) Devices (Part 15, Subpart E) 4. FCC OET KDB 662911 D01 v02r01 - Emissions Testing of Transmitters with Multiple Outputs in the Same Band. 5. ANSI C63.10-2013 American National Standard of Procedures for Compliance Testing of Unlicensed Wireless Devices

2. General conditions, competences and guarantees

- ✓ Tests performed under FCC standards identified in section 1 are covered by A2LA accreditation.
- ✓ Tests performed under ISED standards identified in section 1 are covered by Cofrac accreditation.
- ✓ Intel Corporation SAS Wireless RF Lab (Intel WRF Lab) is an ISO/IEC 17025:2017 laboratory accredited by the American Association for Laboratory Accreditation (A2LA) with the certificate number 3478.01.
- ✓ Intel Corporation SAS Wireless RF Lab (Intel WRF Lab) is an Accredited Test Firm recognized by the FCC, with Designation Number FR0011.
- ✓ Intel Corporation SAS Wireless RF Lab (Intel WRF Lab) is an ISO/IEC 17025:2017 testing laboratory accredited by the French Committee for Accreditation (Cofrac) with the certificate number 1-6736.
- ✓ Intel Corporation SAS Wireless RF Lab (Intel WRF Lab) is a Registered Test Site listed by ISED, with ISED company number 1000Y and CAB identifier FR0005.
- ✓ Intel WRF Lab only provides testing services and is committed to providing reliable, unbiased test results and interpretations.
- ✓ Intel WRF Lab is liable to the client for the maintenance of the confidentiality of all information related to the item under test and the results of the test.
- ✓ Intel WRF Lab has developed calibration and proficiency programs for its measurement equipment to ensure correlated and reliable results to its customers.
- ✓ This report is only referred to the item that has undergone the test.
- ✓ This report does not imply an approval of the product by the Certification Bodies or competent Authorities.

3. Environmental Conditions

- ✓ At the site where the measurements were performed the following limits were not exceeded during the tests:

Temperature	22.7+/-2.1C
Humidity	50.7+/-22.3%

4. Test samples

Sample	Control #	Description	Model	Serial #	Date of receipt	Note
#01	231109-03.S02	WiFi 7 Module	BE201NGW	A002A5B1A62F	2023-11-10	Used for Overlapped channels RF conducted tests
	200904-01.S10	Laptop	HP (HSN-I42C)	000075059C	2023-04-24	
	231109-03.S46	CRF DB 2230 BNJ Extender Board	PCB00862-00_A	ASS00862-01-0A	2023-11-16	
#02	231109-03.S04	WiFi 7 Module	BE201NGW	A002A5B1A56C	2023-11-10	Used for all other RF conducted tests
	231109-03.S53	WiFi 7 Module	BE201NGW	4C496C6BD41A	2023-12-21	
	200203-01.S10	Laptop	HP (HSN-I38C)	000951007L	2023-04-24	
	231109-03.S31	CRF DB 2230 BNJ Extender Board	PCB00862-00_A	ASS00862-01-0A	2023-11-10	
#03	231109-03.S09	WiFi 7 Module	BE201NGW	A002A5B1A61B	2023-11-13	Used for Radiated Spurious Emissions tests
	220225-03.S07	Microwave Absorber	Eccosorb BSR-1	-	2022-03-14	
	231109-03.S48	Adaptor	PCB00866-00_A	124627	2023-11-24	
	200611-03.S31	Extender	ADEXELEC	-	2020-08-19	
	200504-04.S07	Laptop	Latitude 5401	BVHLK13	2020-06-02	
	230223-02.S47	Triband Antenna	-	005	2023-04-20	
	230223-02.S48	Triband Antenna	-	006	2023-04-20	
#04	231109-03.S01	WiFi 7 Module	BE201NGW	A002A5B1A620	2023-11-24	Used for Radiated Spurious Emissions tests
	220225-03.S07	Microwave Absorber	Eccosorb BSR-1	-	2022-03-14	
	231109-03.S47	Adaptor	PCB00866-00_A	124727	2023-11-24	
	220915-09.S01	Extender	ADEXELEC	-	2022-04-06	
	200611-03.S30	Laptop	Latitude 5401	6DJLK13	2020-08-19	
	230223-02.S49	Triband Antenna	-	007	2023-04-20	
	230223-02.S50	Triband Antenna	-	008	2023-04-20	

5. EUT Features

The herein information is provided by the customer

Intel WRF Lab declines any responsibility for the accuracy of the stated customer provided information, especially if it has any impact on the correctness of test results presented in this report.

Brand Name	Intel®		
Model Name	BE201NGW		
Software Version	DRTU.05312.99.0.84 / DRTU.05490.99.0.85		
Driver Version	99.0.84.6 / 99.0.85.2		
Prototype / Production	Production		
Supported Radios	802.11b/g/n/ac/ax/be	2.4GHz	
	802.11a/n/ac/ax/be	5.2GHz	
		5.6GHz	
	802.11ax/be	5.8GHz	
	Bluetooth	6.0GHz	
		2.4GHz	
Antenna Information	Transmitter	Chain A(1)	Chain B(2)
	Manufacturer	Intel WRF Lab	Intel WRF Lab
	Antenna type	PIFA	PIFA
	Part number	WRF-Tri Band-Antenna	WRF-Tri Band-Antenna
	Declared antenna gain (dBi)	+5.15	+5.15

6. Remarks and comments

1. No deviations were made from the test methods listed in section 1 of this report
2. Only the worst-case plot per 802.11 mode and test case measurements have been reported excepted for band edge measurements where all plots are reported

7. Test Verdicts summary

The statement of conformity to applicable standards in the table below are based on the measured values, without taking into account the measurement uncertainties.

7.1. 802.11 a/n/ac/ax/be – U-NII-2C

FCC part	RSS clause	Test name	Verdict
15.407 (a) (2)	RSS-247 Clause 6.2.3.1	Power Limits. Maximum output power	P
15.407 (a) (2)	RSS-247 Clause 6.2.3.1	Power spectral density	P
15.407 (b) (3) 15.209 (a)	RSS-247 Clause 6.2.3.2 RSS-GEN A1 Clause 8.9	Undesirable emissions limits: out of band (conducted)	P
15.407 (b) (3) 15.209 (a)	RSS-247 Clause 6.2.3.2 RSS-GEN A1 Clause 8.9	Undesirable emissions limits: Spurious emissions (radiated)	P

P: Pass

F: Fail

NM: Not Measured

NA: Not Applicable

8. Document Revision History

Revision #	Modified by	Revision Details
Rev. 00	T.MATHIEU R.SIMONINI	First Issue

Annex A. Test & System Description

A.1 Measurement System

Measurements were performed using the following setups, made in accordance to the general provisions of FCC OET KDB 789033 D02 General UNII Test Procedures.

The DUT was installed in a test fixture and this test fixture is connected to a laptop computer and AC/DC power adapter. The laptop computer was used to configure the EUT to continuously transmit at a specified output power using all different modes and modulation schemes, using the Intel proprietary tool DRTU.

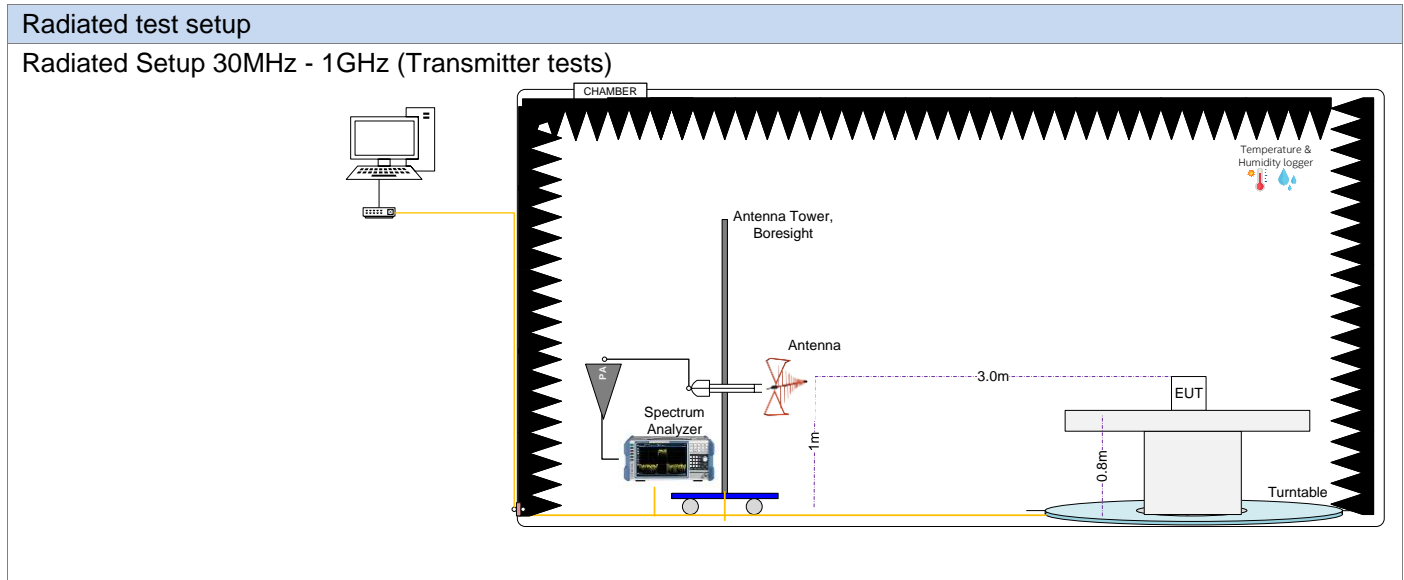
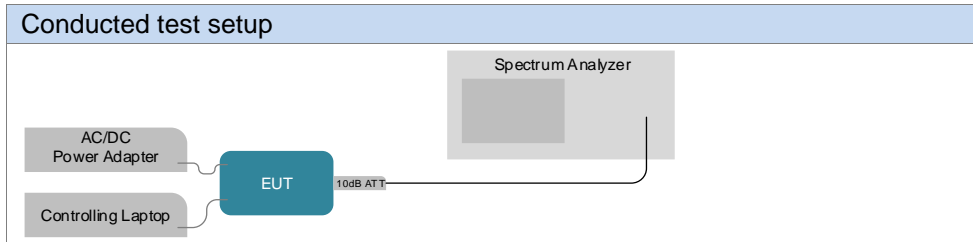

Radiated Setup 1GHz – 10GHz (Transmitter tests)

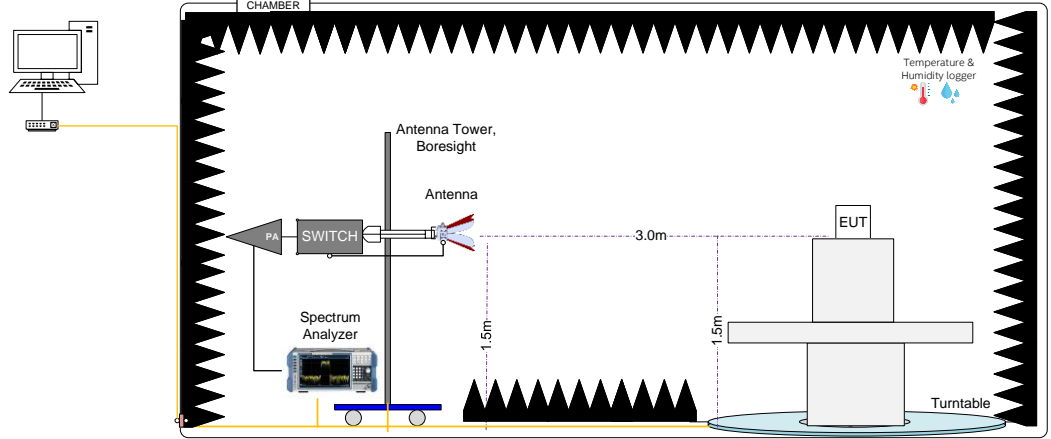

Radiated Setup 10GHz – 40GHz (Transmitter tests)

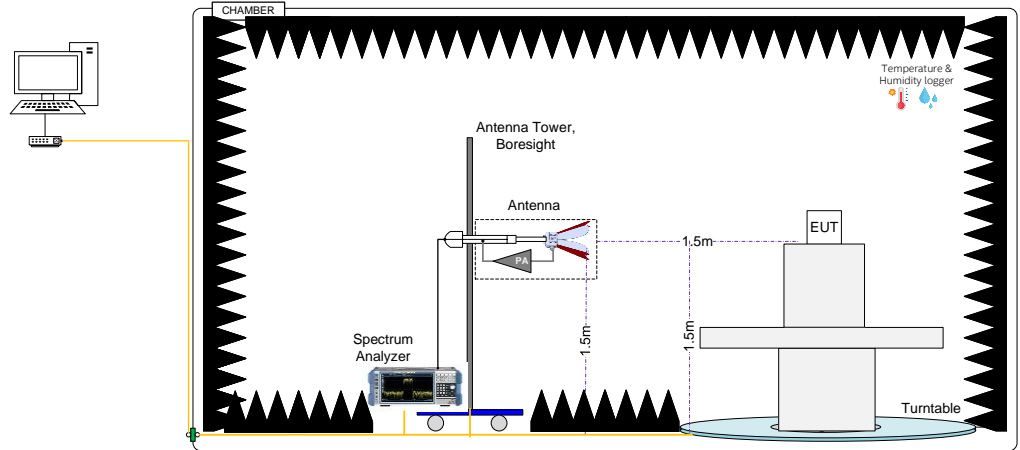

Sample Calculation

The spurious received voltage V (dB μ V) in the spectrum Analyzer is converted to Electric field strength using the transducer factor F corresponding to the Rx path Loss:

$$F \text{ (dB/m)} = \text{Rx Antenna Factor (dB/m)} + \text{Cable losses (dB)} - \text{Amplifiers Gain (dBi)}$$

$$E \text{ (dB}\mu\text{V)} = V \text{ (dB}\mu\text{V)} + F \text{ (dB/m)}$$

For field strength measurements made at other than the distance at which the applicable limit is specified, the field strength of the emission at the distance specified by the limit is deduced as follows:

$$E_{\text{SpecLimit}} = E_{\text{Meas}} + 20 \cdot \log(D_{\text{Meas}}/D_{\text{SpecLimit}})$$

where

$E_{\text{SpecLimit}}$ is the field strength of the emission at the distance specified by the limit, in dB μ V/m

E_{Meas} is the field strength of the emission at the measurement distance, in dB μ V/m

D_{Meas} is the measurement distance, in m

$D_{\text{SpecLimit}}$ is the distance specified by the limit, in m

A.2 Test Equipment List

Conducted setup

ID#	Device	Type/Model	Serial #	Manufacturer	Cal. Date	Cal. Due Date
131-000	Spectrum Analyzer	FSV40	101425	Rohde & Schwarz	2022-07-10	2024-07-10
018-003	RF cable 50cm	PE360-50CM	N/A	PASTERNAK	2023-03-03	2024-03-03
018-001	10dB Attenuator + MH4	N/A	N/A	N/A	2023-03-03	2024-03-03
407-000	Temp & Humidity Logger	RA12E-TH1-RAS	RA12-E16EDA	AVITECH	2023-07-12	2025-07-12
413-000	Measurement SW v1.4.10.8	Octopi	N/A	Step AT	N/A	N/A

Conducted setup for overlapped test

ID#	Device	Type/Model	Serial #	Manufacturer	Cal. Date	Cal. Due Date
266-000	Spectrum Analyzer	FSV30	103307	Rohde & Schwarz	2022-04-26	2024-04-26
019-000	RF cable 50cm	PE360-50CM	N/A	PASTERNAK	2023-03-03	2024-03-03
019-002	10dB Attenuator + MH4	N/A	N/A	N/A	2023-03-03	2024-03-03
407-000	Temp & Humidity Logger	RA12E-TH1-RAS	RA12-E16EDA	AVITECH	2023-07-12	2025-07-12
413-000	Measurement SW v1.5.4.2	Octopi	N/A	Step AT	N/A	N/A

Radiated Setup #1

ID#	Device	Type/Model	Serial #	Manufacturer	Cal. Date	Cal. Due Date
006-000	Anechoic Chamber	FACT3	5720	ETS-Lindgren	2022-01-21	2024-01-21
006-008	Measurement SW, v11.30	EMC32	100623	Rohde & Schwarz	N/A	N/A
259-000	Temp & Humidity Logger	RA12E-TH-RAS	RA12-B9BD70	Avtech	2022-06-27	2024-06-27
006-001	Turn Table	ETS	-	ETS-Lindgren	N/A	N/A
006-011	Boresight antenna mast	BAM 4.0-P	P/278/2890.01	Maturo	N/A	N/A
007-008	Double Horn Ridged antenna +PA	3116C-PA	00169308bis + 00196308	ETS-Lindgren	2023-0-30	2025-05-30
057-000	Double Horn Ridged antenna	3117	167062	ETS-Lindgren	2022-07-08	2024-07-08
058-000	Double Horn Ridged antenna	3116C	157511	ETS-Lindgren	2022-10-21	2024-10-21
006-061	Bi-Log Periodic antenna	CBL6143A	61382	Teseq	2022-10-24	2024-10-24
147-000	Spectrum analyzer	FSW43	101847	Rohde & Schwarz	2022-11-30	2024-11-30
301-000	Amplifier 9kHz-1300MHz	8447F	3113A07440	HP	2023-03-03	2024-03-03
261-000	Amplifier 1GHz-18GHz	3117-PA	00157993	ETS-Lindgren	2023-02-20	2024-02-20
502-006	Amplifier 0.5GHz-40GHz	DEPA0540-43	2023A05	Diamond Engineering	2023-06-09	2024-06-09
009-007	RF Filter	ZHSS-k11G+	8493 1831830	Mini-Circuits	2023-06-09	2024-06-09
006-068	RF Switch	RC-2SP6T-40	02112090061	Micro-Circuits	2023-08-22	2024-08-22
006-059	Cable 7m – 25MHz to 40GHz	R286304174	20.46.369	Radiall	2023-02-20	2024-02-20
006-063	Cable 30cm – 1GHz to 40GHz	PE371-12	-	Pasternack	2023-02-27	2024-02-27
006-064	Cable 30cm – 1GHz to 40GHz	PE371-12	-	Pasternack	2023-02-27	2024-02-27
006-065	Cable 60cm – 25MHz to 1GHz	PE300-24	-	Pasternack	2023-06-02	2024-06-02

N/A: Not Applicable

Radiated Setup #2

ID#	Device	Type/Model	Serial #	Manufacturer	Cal. Date	Cal. Due Date
127-000	Spectrum Analyzer	FSV40	101358	Rohde & Schwarz	2023-01-27	2025-01-27
007-007	Double Ridge Horn (1- 18GHz)	3117	00152266	ETS Lindgren	2022-03-29	2024-03-29
007-006	Switch & Positioner	EMCenter	00151232	ETS Lindgren	N/A	N/A
007-011	RF Cable 1-18GHz - 6.5m	140-8500-11-51	001	Atem	2023-02-15	2024-02-15
007-005	Measurement SW, v11.20.00	EMC32	100401	Rohde & Schwarz	N/A	N/A
007-000	Anechoic chamber	RFD-FA-100	5996	ETS Lindgren	2021-09-14	2024-03-14
007-003	Antenna Tower	2171B-3.0M	00150123	ETS Lindgren	N/A	N/A
007-002	Turntable	-	-	ETS Lindgren	N/A	N/A
007-014	RF Cable 18-40 GHz 6m	R286304009	1747364	Radiall	2023-02-16	2024-02-16
007-022	RF Cable 1-18GHz, 1.5m	0501050991200GX	19.23.493	Radiall	2023-02-13	2024-02-13
007-015	RF Cable 1GHz-18GHz 1.5m	-	-	Spirent	2023-02-13	2024-02-13
007-018	RF Cable 1-9.5GHz 1.2m	0500990991200KE	-	Radiall	2023-02-13	2024-02-13
007-020	RF Cable 1-18GHz, 1.2 m	2301761761200PJ	12.22.1104	Radiall	2023-02-15	2024-02-15
325-000	Temp & Humidity Logger	RA12E-TH1-RAS	RA12-B9B7C6	Avtech	2022-01-17	2024-01-17

N/A: Not Applicable

Shared Radiated Equipment

ID#	Device	Type/Model	Serial #	Manufacturer	Cal. Date	Cal. Due Date
412-000	DRTU Power finder V2.1	-	-	Intel	NA	NA
139-000	Power Sensor	NRP-Z81	104383	Rohde & Schwarz	2023-04-21	2025-04-21
061-000	Power Sensor	NRP-Z81	104386	Rohde & Schwarz	2022-03-25	2024-03-25
140-000	Power Sensor	NRP-Z81	104382	Rohde & Schwarz	2022-03-25	2024-03-25
423-000	Power Sensor	NRP-Z81	101152	Rohde & Schwarz	2022-05-18	2024-05-18

N/A: Not Applicable

A.3 Measurement Uncertainty Evaluation

The system uncertainty evaluation is shown in the table below with a coverage factor of $k = 2$ to indicate a 95% level of confidence:

Measurement type	Uncertainty	Unit
Timing	± 0.12	%
Power Spectral density	± 1.47	dB
Occupied bandwidth	± 2.07	%
Conducted Power	± 1.03	dB
Conducted Spurious Emission <26.5 GHz	± 3.45	dB
Radiated tests <1GHz	± 6.40	dB
Radiated tests 1GHz – 40 GHz	± 6.04	dB

Annex B. Test Results U-NII-2C

The herein test results were performed by:

Test case measurement	Test Peronnel
Power Limits. Maximum output power	T.MATHIEU, C.REQUIN
Power spectral density	T.MATHIEU, C.REQUIN
Undesirable emissions limits: out of band (conducted)	T.MATHIEU
Undesirable emissions limits (radiated)	K.KHATIB, R.SIMONINI

B.1 Test Conditions

For 802.11a mode the EUT can transmit at both CHAIN A and CHAIN B RF outputs individually, but not simultaneously.

For 802.11n20 & 802.11ax/be20 (20 MHz channel bandwidth), 802.11n40 & 802.11ax/be40 (40MHz channel bandwidth), 802.11ac80 & 802.11ax/be80 (80MHz channel bandwidth) and 802.11ac160 &802.11ax/be160 (160MHz channel bandwidth) modes the EUT can transmit at both CHAIN A and CHAIN B RF outputs individually, and also simultaneously.

The following data rates were selected based on preliminary testing that identified those rates as the worst cases for output power and spurious levels at the band edges:

Transmission	Mode	Bandwidth (MHz)	Worst Case Data Rate
SISO	802.11a	20	6Mbps
	802.11n	20	HT0
		40	HT0
	802.11ac	80	VHT0
		160	VHT0
802.11ax/be	20/40/80/160	MCS0	
MIMO	802.11n	20/40	HT8
	802.11ac	80/160	VHT0
	802.11ax/be	20/40/80/160	MCS0

Alternative channels to the lowest and highest channels per band have been also tested for Band Edge compliance.

B.2 Test Results Tables

B.2.1 26dB & 99% Bandwidth

Test procedure

The conducted setup shown in section *Test & System Description* was used to measure the 26dB & 99% bandwidth. The antenna terminal of the EUT is connected to the spectrum analyzer through an attenuator, and the spectrum analyzer reading is compensated to include the RF path loss.

For the overlapped channels between U-NII-2C and U-NII-3 bands, and according to FCC OET KDB 789033 D02, the boundary frequency between the bands is used as one edge for defining the portion of the 26dB bandwidth that falls within a particular U-NII band. This rule is only applicable for the 26dB bandwidth and for those channels marked as overlapped.

Results tables

U-NII-2C channels

Mode	Rate	Antenna	Channel	Freq [MHz]	26dB BW [MHz]	99% BW [MHz]		
802.11a	6Mbps	SISO A	100	5500	24.30	16.64		
			120	5600	24.10	16.83		
			140	5700	24.30	16.73		
		SISO B	100	5500	24.50	16.70		
			120	5600	24.75	16.76		
			140	5700	24.35	16.75		
802.11n20	HT0	SISO A	100	5500	24.35	17.74		
			120	5600	24.75	17.81		
			140	5700	25.25	17.83		
		SISO B	100	5500	24.60	17.77		
			120	5600	25.05	17.81		
			140	5700	24.85	17.81		
	HT8	MIMO A	100	5500	24.65	17.79		
			120	5600	24.95	17.73		
			140	5700	24.70	17.75		
		MIMO B	100	5500	24.65	17.74		
			120	5600	24.30	17.89		
			140	5700	24.60	17.89		
802.11n40	HT0	SISO A	102	5510	44.64	36.08		
			118	5590	47.63	36.40		
			134	5670	44.55	36.16		
		SISO B	102	5510	44.28	36.16		
			118	5590	45.43	36.16		
			134	5670	44.11	36.16		
	HT8	MIMO A	102	5510	43.47	36.16		
			118	5590	43.34	36.08		
			134	5670	43.78	36.08		
		MIMO B	102	5510	42.39	36.16		
			118	5590	42.79	35.92		
			134	5670	42.57	36.24		
802.11ac80	VHT0	SISO A	106	5530	87.97	75.24		
			122	5610	88.16	75.12		
		SISO B	106	5530	87.40	75.24		
			122	5610	86.26	75.24		
		MIMO A	106	5530	86.83	75.00		
			122	5610	86.07	75.12		
		MIMO B	106	5530	86.07	75.12		
			122	5610	86.45	75.00		
		802.11ac160	VHT0	SISO A	114	5570	164.67	153.75
				SISO B			164.01	153.50
MIMO A	165.33			153.75				
MIMO B	164.34			153.75				

Max Value

Mode	Rate	Antenna	Channel	Freq[MHz]	RU config.	26dB BW [MHz]	99% BW [MHz]				
802.11ax/be20	MCS0	SISO A	100	5500	Full	24.65	18.89				
					26/0	20.65	17.96				
					52/37	20.75	17.95				
					106/53	24.00	15.88				
			120	5600	Full	24.90	19.06				
					140	5500	26/8	23.60	18.92		
		52/40					21.25	18.34			
		5700	5500	106/54	21.35	18.41					
				100	5500	Full	23.45	17.96			
						26/0	24.20	18.91			
		SISO B	100	5500	5500	26/0	20.45	18.21			
						52/37	20.70	18.31			
						106/53	23.10	18.30			
						Full	23.75	18.93			
			120	5600	5500	5500	26/8	24.55	18.89		
							52/40	20.95	18.39		
		106/54					21.40	18.32			
		5700	5500	5500	5500	Full	23.30	18.33			
						100	5500	5500	Full	24.50	18.91
									26/0	20.45	17.59
		52/37	20.65	18.19							
		106/53	20.85	17.67							
		MIMO A	120	5600	5500	Full	24.30	18.99			
						140	5500	26/8	24.15	18.88	
52/40	20.70							18.69			
5700	5500		5500	106/54	21.60	18.20					
				100	5500	5500	Full	22.15	18.27		
							26/0	23.80	18.99		
MIMO B	100	5500	5500	26/0	20.10	18.05					
				52/37	20.05	18.06					
				106/53	20.95	18.13					
				Full	24.45	18.96					
	120	5600	5500	5500	Full	24.00	18.91				
					140	5700	5700	26/8	20.35	18.51	
52/40								20.50	17.62		
5700	5700	5700	5700	106/54	20.55	18.17					
				SISO A	102	5510	5510	Full	44.37	37.60	
								242/62	24.66	18.88	
118	5590	5590	Full					45.72	37.60		
			Full					43.56	37.60		
SISO B	134	5670	5670	242/62	24.12	18.96					
				Full	43.56	37.60					
	102	5510	5510	5510	242/62	24.03	18.72				
					Full	44.55	37.76				
MIMO A	118	5590	5590	5590	Full	43.47	37.60				
					242/62	24.57	18.88				
	134	5670	5670	5670	Full	43.83	37.44				
					242/62	26.73	18.64				
MIMO B	102	5510	5510	5510	Full	43.29	37.60				
					242/62	26.28	18.88				
	118	5590	5590	5590	Full	43.47	37.44				
					242/62	26.28	18.88				
134	5670	5670	5670	Full	43.11	37.36					
				242/62	26.28	18.88					
				Full	41.49	37.68					
134	5670	5670	5670	Full	42.30	37.68					
				Full	42.30	37.68					
				242/62	26.28	18.80					

802.11ax/be80	MCS0	SISO A	106	5530	Full	83.22	76.68		
					484/65	48.45	37.44		
			122	5610	Full	84.55	76.80		
		SISO B			106	5530	Full	83.41	76.68
							484/65	45.60	37.32
					122	5610	Full	84.17	76.80
		MIMO A			106	5530	Full	83.41	76.92
							484/65	43.51	37.44
					122	5610	Full	83.98	76.80
		MIMO B			106	5530	Full	85.50	76.68
							484/65	43.32	37.32
					122	5610	Full	83.98	76.56
802.11ax/be160	MCS0	SISO A	114	5570	Full	163.35	155.00		
					996/67	86.79	77.00		
					996/S67	91.08	77.25		
		SISO B			Full	163.02	154.75		
					996/67	83.49	77.00		
					996/S67	83.82	77.25		
		MIMO A			Full	163.35	155.25		
					996/67	82.50	77.00		
					996/S67	91.41	77.25		
		MIMO B			Full	163.35	155.00		
					996/67	83.82	76.75		
					996/S67	89.76	77.50		

Max Value

Overlapped channels between U-NII-2C and U-NII-3

Mode	Rate	Channel	Frequency [MHz]	Antenna	Chain	26dB BW [MHz] UNII2C
802.11n20	HT0	144	5720	SISO	A	17.17
					B	17.73
	HT8			MIMO	A	17.17
					B	17.13
802.11n40	HT0	142	5710	SISO	A	48.15
					B	38.75
	HT8			MIMO	A	36.35
					B	35.85
802.11ac80	VHT0	138	5690	SISO	A	84.14
					B	80.30
				MIMO	A	77.18
					B	77.54
802.11ax/be20	MCS0	144	5720	SISO	A	17.28
					B	17.13
				MIMO	A	16.92
					B	17.38
802.11ax/be40	MCS0	142	5710	SISO	A	40.25
					B	42.05
				MIMO	A	36.05
					B	36.25
802.11ax/be80	MCS0	138	5690	SISO	A	83.18
					B	79.94
				MIMO	A	75.86

					B	75.74
--	--	--	--	--	---	-------

Max Value

See Section B.3.1 and Section B.3.2 for the screenshot results.

B.2.2 Power Limits. Maximum Output power & Maximum power spectral Density

Test limits

Part	Limits
FCC 15.407 (a) (2)	For the 5.25–5.35 GHz and 5.47–5.725 GHz bands, the maximum conducted output power over the frequency bands of operation shall not exceed the lesser of 250 mW or $11 \text{ dBm} + 10 \log B$, where B is the 26 dB emission bandwidth in megahertz. In addition, the peak power spectral density shall not exceed 11 dBm in any 1 megahertz band.
RSS-247 Clause 6.2.3 (1)	The maximum conducted output power shall not exceed 250 mW or $11 + 10 \log_{10} B$, dBm, whichever is less. The power spectral density shall not exceed 11 dBm in any 1.0 MHz band. The maximum e.i.r.p. shall not exceed 1.0 W or $17 + 10 \log_{10} B$, dBm, whichever is less. B is the 99% emission bandwidth in megahertz. Note that devices with a maximum e.i.r.p. greater than 500 mW shall implement TPC in order to have the capability to operate at least 6 dB below the maximum permitted e.i.r.p. of 1 W.

Test procedure

The Maximum Conducted Output Power was measured using the channel integration method according to section E) 2) e) (Method SA-2 Alternative) of FCC OET KDB 789033 D02.

The maximum power spectral density (PSD) was measured using the method according to section F) (Method SA-2 Alternative) of FCC OET KDB 789033 D02.

In the measure-and-sum approach for MIMO mode, the conducted emission level (e.g., transmit power or power in specified bandwidth) is measured at each antenna port. The measured results at the various antenna ports are then summed mathematically in linear power units to determine the total emission level from the device.

The EIRP power (dBm) is calculated by adding the declared maximum antenna gain to the measured conducted power.

The conducted setup shown in section *Test & System Description* was used to measure the maximum conducted output power and power spectral density. The antenna terminal of the EUT is connected to the spectrum analyser through an attenuator, and the spectrum analyzer reading is compensated to include the RF path loss.

For the overlapped channels between U-NII-2C and U-NII-3, and according to FCC OET KDB 789033 D02 the power is computed based on the portion of the emission bandwidth contained within that band. This rule is only applicable for those channels marked as overlapped

Results tables
Duty cycle

Mode	Rate	Antenna	Duty Cycle [%]
802.11a	6Mbps	SISO A	97.739
		SISO B	97.739
802.11n20	HT0	SISO A	98.785
		SISO B	98.785
	HT8	MIMO A	99.574
		MIMO B	99.574
802.11ax/be20	MCS0	SISO A	98.778
		SISO B	98.778
		MIMO A	99.671
		MIMO B	99.671
802.11n40	HT0	SISO A	98.8
		SISO B	98.8
	HT8	MIMO A	99.353
		MIMO B	99.353
802.11ax/be40	MCS0	SISO A	98.793
		SISO B	98.793
		MIMO A	99.895
		MIMO B	99.895
802.11ac80	VHT0	SISO A	98.795
		SISO B	98.795
		MIMO A	98.777
		MIMO B	98.777
802.11ax/be80	MCS0	SISO A	98.793
		SISO B	98.793
		MIMO A	98.784
		MIMO B	98.784
802.11ac160	VTH0	SISO A	98.796
		SISO B	98.796
		MIMO A	98.283
		MIMO B	98.283
802.11ax/be160	MCS0	SISO A	98.784
		SISO B	98.784
		MIMO A	98
		MIMO B	98

Maximum output power – U-NII-2C Channels

Mode	Rate	#Ch	Freq [MHz]	Antenna	Average Conducted Output Power [dBm]	Avg Max Conducted Output Power [dBm]	Avg Max . EIRP [dBm]	Avg Max Conducted Power [mW]	
802.11a	6Mbps	100	5500	SISO A	20.93	21.03	26.18	126.75	
				SISO B	21.14	21.24	26.39	133.02	
		120	5600	SISO A	21.30	21.40	26.55	138.02	
				SISO B	20.96	21.06	26.21	127.62	
		140	5700	SISO A	21.23	21.33	26.48	135.81	
				SISO B	20.85	20.95	26.10	124.43	
802.11n20	HT0	100	5500	SISO A	21.41	21.41	26.56	138.36	
				SISO B	21.04	21.04	26.19	127.06	
		120	5600	SISO A	21.22	21.22	26.37	132.43	
				SISO B	21.43	21.43	26.58	139.00	
		140	5700	SISO A	21.16	21.16	26.31	130.62	
				SISO B	21.36	21.36	26.51	136.77	
	HT8	100	5500	MIMO A	18.10	18.10	23.25	64.57	
				MIMO B	17.85	17.85	23.00	60.95	
				Combined A+B	20.99	20.99	26.14	125.52	
		120	5600	MIMO A	18.58	18.58	23.73	72.11	
				MIMO B	18.19	18.19	23.34	65.92	
				Combined A+B	21.40	21.40	26.55	138.03	
	140	5700	MIMO A	18.04	18.04	23.19	63.68		
			MIMO B	18.12	18.12	23.27	64.86		
			Combined A+B	21.09	21.09	26.24	128.54		
	802.11n40	HT0	102	5510	SISO A	21.44	21.44	26.59	139.32
					SISO B	22.44	22.44	27.59	175.39
			118	5590	SISO A	23.28	23.28	28.43	212.81
SISO B					22.82	22.82	27.97	191.43	
134			5670	SISO A	21.89	21.89	27.04	154.53	
				SISO B	21.80	21.80	26.95	151.36	
HT8		102	5510	MIMO A	19.60	19.60	24.75	91.20	
				MIMO B	19.57	19.57	24.72	90.57	
				Combined A+B	22.60	22.60	27.75	181.77	
		118	5590	MIMO A	21.15	21.15	26.30	130.32	
				MIMO B	20.73	20.73	25.88	118.30	
				Combined A+B	23.96	23.96	29.11	248.62	
134	5670	MIMO A	21.04	21.04	26.19	127.06			
		MIMO B	20.60	20.60	25.75	114.82			
		Combined A+B	23.84	23.84	28.99	241.87			
802.11ac80	VHT0	106	5530	SISO A	21.46	21.46	26.61	139.96	
				SISO B	21.57	21.57	26.72	143.55	
				MIMO A	19.58	19.58	24.73	90.78	
				MIMO B	18.84	18.84	23.99	76.56	
				Combined A+B	22.24	22.24	27.39	167.34	
		122	5610	SISO A	21.19	21.19	26.34	131.52	
				SISO B	21.38	21.38	26.53	137.40	
				MIMO A	21.06	21.06	26.21	127.64	
				MIMO B	20.69	20.69	25.84	117.22	
				Combined A+B	23.89	23.89	29.04	244.86	
802.11ac160	VHT0	114	5570	SISO A	18.11	18.11	23.26	64.71	
				SISO B	18.97	18.97	24.12	78.89	
				MIMO A	17.45	17.45	22.60	55.59	
				MIMO B	17.31	17.31	22.46	53.83	
				Combined A+B	20.39	20.39	25.54	109.42	

* Maximum values are the duty cycle compensated values calculated from the average (measured) values

Max/Min Value

Mode	Rate	#Ch	Freq [MHz]	Antenna	RU config.	Average Conducted Output Power [dBm]	Avg Max Conducted Output Power [dBm]	Avg Max EIRP [dBm]	Avg Max Conducted Power [mW]				
802.11ax/be20	MCS0	100	5500	SISO A	Full	21.26	21.26	26.41	133.66				
					26/0	12.75	12.75	17.90	18.84				
					52/37	15.85	15.85	21.00	38.46				
					106/53	18.74	18.74	23.89	74.82				
				SISO B	Full	21.40	21.40	26.55	138.04				
					26/0	13.07	13.07	18.22	20.28				
					52/37	16.16	16.16	21.31	41.30				
					106/53	18.71	18.71	23.86	74.30				
				MIMO A	Full	18.17	18.17	23.32	65.61				
					26/0	10.02	10.02	15.17	10.05				
					52/37	13.04	13.04	18.19	20.14				
					106/53	15.70	15.70	20.85	37.15				
		MIMO B	Full	18.25	18.25	23.40	66.83						
			26/0	10.12	10.12	15.27	10.28						
			52/37	13.02	13.02	18.17	20.04						
			106/53	15.49	15.49	20.64	35.40						
		Combined A+B	Full	21.22	21.22	26.37	132.45						
			26/0	13.08	13.08	18.23	20.33						
			52/37	16.04	16.04	21.19	40.18						
			106/53	18.61	18.61	23.76	72.55						
		120	5600	SISO A	Full	21.08	21.08	26.23	128.23				
					SISO B	Full	21.35	21.35	26.50	136.46			
					MIMO A	Full	18.05	18.05	23.20	63.83			
					MIMO B	Full	18.11	18.11	23.26	64.71			
					Combined A+B	Full	21.09	21.09	26.24	128.54			
		140	5700	SISO A	Full	21.06	21.06	26.21	127.64				
					26/0	13.22	13.22	18.37	20.99				
					52/37	15.82	15.82	20.97	38.19				
					106/53	17.88	17.88	23.03	61.38				
				SISO B	Full	21.18	21.18	26.33	131.22				
					26/0	13.22	13.22	18.37	20.99				
					52/37	15.88	15.88	21.03	38.73				
					106/53	17.84	17.84	22.99	60.81				
				MIMO A	Full	17.95	17.95	23.10	62.37				
					26/0	10.21	10.21	15.36	10.50				
					52/37	12.68	12.68	17.83	18.54				
					106/53	15.23	15.23	20.38	33.34				
				MIMO B	Full	18.01	18.01	23.16	63.24				
					26/0	10.05	10.05	15.20	10.12				
					52/37	12.67	12.67	17.82	18.49				
					106/53	15.55	15.55	20.70	35.89				
				Combined A+B	Full	20.99	20.99	26.14	125.61				
					26/0	13.14	13.14	18.29	20.61				
					52/37	15.69	15.69	20.84	37.03				
					106/53	18.40	18.40	23.55	69.23				
				802.11ax/be40	MCS0	102	5510	SISO A	Full	21.32	21.32	26.47	135.52
									242/62	21.63	21.63	26.78	145.55
								SISO B	Full	22.35	22.35	27.50	171.79
242/62	21.47								21.47	26.62	140.28		
MIMO A	Full	18.99	18.99					24.14	79.25				
	242/62	18.32	18.32					23.47	67.92				
MIMO B	Full	19.66	19.66					24.81	92.47				
	242/62	18.44	18.44					23.59	69.82				
Combined A+B	Full	22.35	22.35			27.50	171.72						
	242/62	21.39	21.39			26.54	137.74						
118	5590	SISO A	Full			23.20	23.20	28.35	208.93				
			Full			22.77	22.77	27.92	189.23				
		MIMO A	Full			21.04	21.04	26.19	127.06				
			Full			20.62	20.62	25.77	115.35				
Combined A+B	Full	23.85	23.85			29.00	242.40						
	Full	21.07	21.07			26.22	127.94						
134	5670	SISO A	242/62			21.30	21.30	26.45	134.90				
			Full			21.69	21.69	26.84	147.57				

				242/62	21.28	21.28	26.43	134.28
			MIMO A	Full	20.93	20.93	26.08	123.88
				242/62	18.09	18.09	23.24	64.42
			MIMO B	Full	20.46	20.46	25.61	111.17
				242/62	18.14	18.14	23.29	65.16
			Combined A+B	Full	23.71	23.71	28.86	235.05
				242/62	21.13	21.13	26.28	129.58

* Maximum values are the duty cycle compensated values calculated from the average (measured) values

Max/Min Value

Mode	Rate	#Ch	Freq [MHz]	Antenna	RU config.	Average Conducted Ouput Power [dBm]	Avg Max Conducted Ouput Power [dBm]	Avg Max . EIRP [dBm]	Avg Max Conducted Power [mW]
802.11ax/be80	MCS0	106	5530	SISO A	Full	21.37	21.37	26.52	137.09
					484/65	17.29	17.29	22.44	53.58
				SISO B	Full	21.48	21.48	26.63	140.60
					484/65	15.58	15.58	20.73	36.14
				MIMO A	Full	19.52	19.52	24.67	89.54
					484/65	19.81	19.81	24.96	95.72
		MIMO B	Full	18.73	18.73	23.88	74.64		
			484/65	19.73	19.73	24.88	93.97		
		Combined A+B	Full	22.15	22.15	27.30	164.18		
			484/65	22.78	22.78	27.93	189.69		
122	5610	SISO A	Full	21.83	21.83	26.98	152.41		
		SISO B	Full	21.31	21.31	26.46	135.21		
		MIMO A	Full	20.52	20.52	25.67	112.72		
		MIMO B	Full	20.62	20.62	25.77	115.35		
		Combined A+B	Full	23.58	23.58	28.73	228.07		
802.11ax/be160	MCS0	114	5570	SISO A	Full	18.11	18.11	23.26	64.71
					996/67	20.69	20.69	25.84	117.22
					996/S67	19.77	19.77	24.92	94.84
				SISO B	Full	18.97	18.97	24.12	78.89
					996/67	20.37	20.37	25.52	108.89
					996/S67	21.91	21.91	27.06	155.24
				MIMO A	Full	17.43	17.43	22.58	55.34
					996/67	19.28	19.28	24.43	84.72
					996/S67	18.71	18.71	23.86	74.30
				MIMO B	Full	17.29	17.29	22.44	53.58
					996/67	19.64	19.64	24.79	92.04
					996/S67	18.59	18.59	23.74	72.28
Combined A+B	Full	20.37	20.37	25.52	108.91				
	996/67	22.47	22.47	27.62	176.77				
	996/S67	21.66	21.66	26.81	146.58				

* Maximum values are the duty cycle compensated values calculated from the average (measured) values

Max/Min Value

Maximum output power – Overlapped channels between U-NII-2C and U-NII-3

Mode	Rate	Antenna	Chain	Channel	Frequency (MHz)	Average Cond. Output Power - UNII-2C [dBm]	Max.* Cond. Output Power - UNII-2C [dBm]	Max.* EIRP UNII2C [dBm]	Max.* Cond. Output Power - UNII-2C [mW]
802.11n20	HT0	SISO	A	144	5720	20.92	20.92	26.07	123.59
			B		5720	20.61	20.61	25.76	115.08
	HT8	MIMO	A		5720	17.82	17.82	22.97	60.53
			B		5720	17.84	17.84	22.99	60.81
			Combined		A+B	5720	20.84	20.84	25.99
802.11n40	HT0	SISO	A	142	5710	22.79	22.79	27.94	190.11
			B		5710	22.61	22.61	27.76	182.39
	HT8	MIMO	A		5710	20.88	20.88	26.03	122.46
			B		5710	20.66	20.66	25.81	116.41
			Combined		A+B	5710	23.78	23.78	28.93
802.11ac80	VHT0	SISO	A	138	5690	22.69	22.69	27.84	185.78
			B		5690	22.45	22.45	27.60	175.79
		MIMO	A		5690	20.89	20.89	26.04	122.74
			B		5690	20.81	20.81	25.96	120.50
		Combined	A+B		5690	23.86	23.86	29.01	243.25
802.11ax/be20	MCS0	SISO	A	144	5720	21.00	21.00	26.15	125.89
			B		5720	20.68	20.68	25.83	116.95
		MIMO	A		5720	17.95	17.95	23.10	62.37
			B		5720	17.66	17.66	22.81	58.34
		Combined	A+B		5720	20.82	20.82	25.97	120.72
802.11ax/be40	MCS0	SISO	A	142	5710	22.86	22.86	28.01	193.20
			B		5710	22.77	22.77	27.92	189.23
		MIMO	A		5710	20.78	20.78	25.93	119.67
			B		5710	20.80	20.80	25.95	120.23
		Combined	A+B		5710	23.80	23.80	28.95	239.90
802.11ax/be80	MCS0	SISO	A	138	5690	22.78	22.78	27.93	189.67
			B		5690	22.79	22.79	27.94	190.11
		MIMO	A		5690	20.42	20.42	25.57	110.15
			B		5690	20.91	20.91	26.06	123.31
		Combined	A+B		5690	23.68	23.68	28.83	233.46

* Maximum values are the duty cycle compensated values calculated from the average (measured) values

Max/Min Value

Maximum Power Spectral Density (PSD) – U-NII-2C channels

Mode	Rate	Channel	Freq [MHz]	Antenna	Average conducted PSD [dBm/MHz]	Maximum* conducted PSD [dBm/MHz]	
802.11a	6Mbps	100	5500	SISO A	10.42	10.52	
				SISO B	10.69	10.79	
		120	5600	SISO A	10.79	10.89	
				SISO B	10.49	10.59	
		140	5700	SISO A	10.69	10.79	
				SISO B	10.42	10.52	
802.11n20	HT0	100	5500	SISO A	10.70	10.70	
				SISO B	10.23	10.23	
		120	5600	SISO A	10.52	10.52	
				SISO B	10.70	10.70	
		140	5700	SISO A	10.50	10.50	
				SISO B	10.69	10.69	
	HT8	100	5500	MIMO A	7.51	7.51	
				MIMO B	7.18	7.18	
				Combined A+B	10.36	10.36	
		120	5600	MIMO A	7.85	7.85	
				MIMO B	7.45	7.45	
				Combined A+B	10.66	10.66	
	140	5700	MIMO A	7.25	7.25		
			MIMO B	7.41	7.41		
			Combined A+B	10.34	10.34		
	802.11n40	HT0	102	5510	SISO A	7.50	7.50
					SISO B	8.30	8.30
			118	5590	SISO A	9.05	9.05
SISO B					8.71	8.71	
134			5670	SISO A	7.74	7.74	
				SISO B	7.66	7.66	
HT8		102	5510	MIMO A	5.53	5.53	
				MIMO B	5.49	5.49	
				Combined A+B	8.52	8.52	
		118	5590	MIMO A	7.10	7.10	
				MIMO B	6.74	6.74	
				Combined A+B	9.93	9.93	
134	5670	MIMO A	6.84	6.84			
		MIMO B	6.57	6.57			
		Combined A+B	9.72	9.72			
802.11ac80	VHT0	106	5530	SISO A	4.24	4.24	
				SISO B	4.42	4.42	
				MIMO A	2.38	2.38	
				MIMO B	1.71	1.71	
				Combined A+B	5.07	5.07	
		122	5610	SISO A	3.93	3.93	
				SISO B	4.18	4.18	
				MIMO A	3.81	3.81	
				MIMO B	3.50	3.50	
				Combined A+B	6.67	6.67	
802.11ac160	VHT0	114	5570	SISO A	-1.78	-1.78	
				SISO B	-1.04	-1.04	
				MIMO A	-2.65	-2.65	
				MIMO B	-2.80	-2.80	
				Combined A+B	0.29	0.29	

* Maximum values are the duty cycle compensated values calculated from the average (measured) values

Mode	Rate	Channel	Freq [MHz]	Antenna	RU config.	Average conducted PSD [dBm/MHz]	Maximum* conducted PSD [dBm/MHz]	
802.11ax/be20	MCS0	100	5500	SISO A	Full	10.62	10.62	
					26/0	10.24	10.24	
					52/37	10.52	10.52	
					106/53	10.31	10.31	
				SISO B	Full	10.67	10.67	
					26/0	10.46	10.46	
					52/37	10.79	10.79	
					106/53	10.47	10.47	
				MIMO A	Full	7.38	7.38	
					26/0	7.60	7.60	
					52/37	7.80	7.80	
					106/53	7.32	7.32	
				MIMO B	Full	7.59	7.59	
					26/0	7.82	7.82	
					52/37	7.72	7.72	
					106/53	7.30	7.30	
		Combined A+B	Full	10.50	10.50			
			26/0	10.72	10.72			
			52/37	10.77	10.77			
			106/53	10.32	10.32			
		120	5600	SISO A	Full	10.30	10.30	
				SISO B	Full	10.52	10.52	
				MIMO A	Full	7.17	7.17	
				MIMO B	Full	7.26	7.26	
				Combined A+B	Full	10.23	10.23	
		140	5500 5700	SISO A	FullBW	10.36	10.36	
					2m	10.69	10.69	
					4m	10.53	10.53	
					8m	9.51	9.51	
				SISO B	FullBW	10.38	10.38	
					2m	10.73	10.73	
					4m	10.37	10.37	
					8m	9.46	9.46	
				MIMO A	FullBW	7.25	7.25	
					2m	7.76	7.76	
					4m	7.24	7.24	
					8m	6.89	6.89	
				MIMO B	FullBW	7.34	7.34	
					2m	7.62	7.62	
					4m	7.23	7.23	
					8m	7.11	7.11	
				Combined A+B	FullBW	10.31	10.31	
					2m	10.70	10.70	
					4m	10.25	10.25	
					8m	10.01	10.01	
		802.11ax/be40	MCS0	102	SISO A	Full	7.17	7.17
						242/62	10.63	10.63
					SISO B	Full	8.23	8.23
242/62	10.60					10.60		
MIMO A	Full				4.85	4.85		
	242/62				7.35	7.35		
MIMO B	Full				5.43	5.43		
	242/62				7.58	7.58		
Combined A+B	Full			8.16	8.16			
242/62	10.48			10.48				
118	5590			SISO A	Full	9.21	9.21	
				SISO B	Full	8.58	8.58	
				MIMO A	Full	6.84	6.84	
				MIMO B	Full	6.35	6.35	
				Combined A+B	Full	9.61	9.61	
134	5670			SISO A	Full	6.86	6.86	
				SISO A	242/62	10.32	10.32	
				SISO B	Full	7.48	7.48	
				SISO B	242/62	10.44	10.44	

	MIMO A	Full	6.77	6.77
		242/62	7.21	7.21
	MIMO B	Full	6.23	6.23
		242/62	7.14	7.14
	Combined A+B	Full	9.52	9.52
		242/62	10.19	10.19

* Maximum values are the duty cycle compensated values calculated from the average (measured) values

Mode	Rate	Channel	Freq [MHz]	Antenna	RU config.	Average conducted PSD [dBm/MHz]	Maximum* conducted PSD [dBm/MHz]
802.11ax/be80	MCS0	106	5530	SISO A	Full	4.21	4.21
					484/65	3.02	3.02
				SISO B	Full	4.24	4.24
					484/65	1.33	1.33
				MIMO A	Full	2.49	2.49
					484/65	5.54	5.54
		MIMO B	Full	1.77	1.77		
			484/65	5.49	5.49		
		Combined A+B	Full	5.16	5.16		
			484/65	8.53	8.53		
		122	5610	SISO A	Full	4.79	4.79
					Full	4.21	4.21
				MIMO A	Full	3.28	3.28
					Full	3.47	3.47
Combined A+B	Full			6.39	6.39		
802.11ax/be160	MCS0	114	5570	SISO A	Full	-1.97	-1.97
					996/67	3.75	3.75
					996/S67	2.83	2.83
				SISO B	Full	-1.08	-1.08
					996/67	3.42	3.42
					996/S67	4.70	4.70
				MIMO A	Full	-2.58	-2.58
					996/67	2.09	2.09
					996/S67	1.45	1.45
				MIMO B	Full	-2.67	-2.67
					996/67	2.63	2.63
					996/S67	1.38	1.38
				Combined A+B	Full	0.39	0.39
					996/67	5.38	5.38
996/S67	4.43	4.43					

* Maximum values are the duty cycle compensated values calculated from the average (measured) values

Maximum Power Spectral Density (PSD) – Overlapped channels between U-NII-2C and U-NII-3

Mode	Rate	Channel	Frequency (MHz)	Antenna	Chain	Average conducted PSD UNII-2C [dBm/MHz]	Maximum* conducted PSD UNII-2C [dBm/MHz]
802.11n20	HT0	144	5720	SISO	A	10.87	10.87
					B	10.58	10.58
	HT8			MIMO	A	7.91	7.91
					B	7.87	7.87
	Combined			A+B	10.90	10.90	
802.11n40	HT0	142	5710	SISO	A	8.95	8.95
					B	8.72	8.72
	HT8			MIMO	A	6.94	6.94
					B	6.79	6.79
	Combined			A+B	9.88	9.88	
802.11ac80	VHT0	138	5690	SISO	A	5.64	5.64
					B	5.35	5.35
				MIMO	A	3.84	3.84
					B	3.64	3.64
				Combined	A+B	6.75	6.75
802.11ax/be20	MCS0	144	5720	SISO	A	10.98	10.98
					B	10.60	10.60
				MIMO	A	7.92	7.92
					B	7.61	7.61
				Combined	A+B	10.78	10.78
802.11ax/be40	MCS0	142	5710	SISO	A	8.96	8.96
					B	9.05	9.05
				MIMO	A	6.76	6.76
					B	6.94	6.94
				Combined	A+B	9.86	9.86
802.11ax/be80	MCS0	138	5690	SISO	A	5.62	5.62
					B	5.86	5.86
				MIMO	A	3.39	3.39
					B	3.89	3.89
				Combined	A+B	6.66	6.66

* Maximum values are the duty cycle compensated values calculated from the average (measured) values

See Section B.3.3 for the screenshot results.

B.2.3 Undesirable emission limits : out of band (Conducted)

Test limits

FCC part	RSS clause	Limits																				
15.407 (b) (3)	RSS-247 Clause 6.2.3 (2)	For transmitters operating in the 5.47–5.725 GHz band: all emissions outside of the 5.47–5.725 GHz band shall not exceed an EIRP of -27 dBm/MHz.																				
15.209	RSS-GEN A1, Clause 8.9	<p>Radiated emissions which fall in the restricted bands, as defined in §15.205(a), must also comply with the radiated emission limits specified in §15.209(a):</p> <table border="1"> <thead> <tr> <th>Freq Range (MHz)</th> <th>Field Strength ($\mu\text{V}/\text{m}$)</th> <th>Field Strength ($\text{dB}\mu\text{V}/\text{m}$)</th> <th>Meas. Distance (m)</th> </tr> </thead> <tbody> <tr> <td>30-88</td> <td>100</td> <td>40</td> <td>3</td> </tr> <tr> <td>88-216</td> <td>150</td> <td>43.5</td> <td>3</td> </tr> <tr> <td>216-960</td> <td>200</td> <td>46</td> <td>3</td> </tr> <tr> <td>Above 960</td> <td>500</td> <td>54</td> <td>3</td> </tr> </tbody> </table> <p>The emission limits shown in the table above are based on measurements employing CISPR quasi-peak detector except for the frequency bands 9-90 kHz, 110-490 kHz and above 1000 MHz. Radiated emission limits in these three bands are based on measurements employing an average detector.</p> <p>For average radiated emission measurements above 1000 MHz, there is also a limit specified when measuring with peak detector function, corresponding to 20 dB above the indicated values in the table.</p>	Freq Range (MHz)	Field Strength ($\mu\text{V}/\text{m}$)	Field Strength ($\text{dB}\mu\text{V}/\text{m}$)	Meas. Distance (m)	30-88	100	40	3	88-216	150	43.5	3	216-960	200	46	3	Above 960	500	54	3
Freq Range (MHz)	Field Strength ($\mu\text{V}/\text{m}$)	Field Strength ($\text{dB}\mu\text{V}/\text{m}$)	Meas. Distance (m)																			
30-88	100	40	3																			
88-216	150	43.5	3																			
216-960	200	46	3																			
Above 960	500	54	3																			

Test procedure

The conducted setup shown in section *Test & System Description* was used to measure undesirable emissions on the out of band domain. The antenna terminal of the EUT is connected to the spectrum analyzer through an attenuator, and the spectrum analyzer reading is compensated to include the RF path loss and the declared antenna gain.

Both lower and upper side of the out of band were performed using the integration method as defined in the out of band measurements section (paragraph II.G.3.d) of FCC OET KDB 789033 D02

In case of out of band measurements falling in restricted bands, the declared antenna gain is also compensated in the graph.

The following limits in dBm were applied for the average detector after the conversion from the limits detailed above in $\text{dB}\mu\text{V}/\text{m}$, according to FCC 47 CFR part 15 - Subpart C – §15.209(a). The limits in dBm for peak detector are 20dB above the indicated values in the table.

§15.209(a)			Converted values	
Freq Range (MHz)	Distance (m)	Field strength (microvolts/meter)	Field strength (dB microvolts/meter)	Power (dBm)
Above 960	3	500	53.98	-41.2

See Section B.3.4 for the screenshot results.

B.2.4 Radiated spurious emission

Standard references

FCC part	RSS clause	Limits																				
15.407 (b) (3)	RSS-247 Clause 6.2.3 (2)	For transmitters operating in the 5.47–5.725 GHz band: all emissions outside of the 5.47–5.725 GHz band shall not exceed an EIRP of -27 dBm/MHz.																				
15.209	RSS-GEN A1, Clause 8.9	<p>Radiated emissions which fall in the restricted bands, as defined in §15.205(a), must also comply with the radiated emission limits specified in §15.209(a):</p> <table border="1"> <thead> <tr> <th>Freq Range (MHz)</th> <th>Field Strength ($\mu\text{V}/\text{m}$)</th> <th>Field Strength ($\text{dB}\mu\text{V}/\text{m}$)</th> <th>Meas. Distance (m)</th> </tr> </thead> <tbody> <tr> <td>30-88</td> <td>100</td> <td>40</td> <td>3</td> </tr> <tr> <td>88-216</td> <td>150</td> <td>43.5</td> <td>3</td> </tr> <tr> <td>216-960</td> <td>200</td> <td>46</td> <td>3</td> </tr> <tr> <td>Above 960</td> <td>500</td> <td>54</td> <td>3</td> </tr> </tbody> </table> <p>The emission limits shown in the above table are based on measurements employing CISPR quasi-peak detector except for the frequency bands above 1000 MHz. Radiated emission limits in these three bands are based on measurements employing an average detector.</p> <p>For average radiated emission measurements above 1000 MHz, there is also a limit specified when measuring with peak detector function, corresponding to 20 dB above the indicated values in the table.</p>	Freq Range (MHz)	Field Strength ($\mu\text{V}/\text{m}$)	Field Strength ($\text{dB}\mu\text{V}/\text{m}$)	Meas. Distance (m)	30-88	100	40	3	88-216	150	43.5	3	216-960	200	46	3	Above 960	500	54	3
Freq Range (MHz)	Field Strength ($\mu\text{V}/\text{m}$)	Field Strength ($\text{dB}\mu\text{V}/\text{m}$)	Meas. Distance (m)																			
30-88	100	40	3																			
88-216	150	43.5	3																			
216-960	200	46	3																			
Above 960	500	54	3																			

Test procedure

The radiated setup shown in section *Test & System Description* was used to measure the radiated spurious emissions. Depending of the frequency range and bands being tested, different antennas and filters were used. The final measurement is done by varying the antenna height, the EUT azimuth over 360° and for both Vertical and Horizontal polarizations.

The radiated spurious emission was measured on the worst case configuration selected from the section B.2.2 and using the low, middle and high channels.

Test Results

Radiated spurious - 30 MHz to 1 GHz

Radiated Spurious – All modes

Frequency	Level	Detector	Limit	Margin	Polarization
MHz	dBµV/m	---	dBµV/m	dB	---
36.1	33.6	Quasi-Peak	40.0	6.4	V
47.8	35.2	Quasi-Peak	40.0	4.8	V
87.5	36.4	Quasi-Peak	40.0	3.6	V

Note 1: The spurious signals detected do not depend on either the operating channel or the modulation mode.

802.11a

1 GHz – 40 GHz, 802.11a, 6Mbps, Chain A

Radiated Spurious – CH100

Frequency	Level	Detector	Limit	Margin	Polar
MHz	dBµV/m	---	dBµV/m	dB	---
8253.4	57.2	Peak	74.0	16.8	H
8254.0	47.2	Average	54.0	6.8	H
10997.5	59.2	Peak	74.0	14.8	H
10997.5	48.9	Average	54.0	5.1	H
11001.0	50.2	Average	54.0	3.8	H
11001.5	61.0	Peak	74.0	13.0	H

Radiated Spurious – CH120

Frequency	Level	Detector	Limit	Margin	Polar
MHz	dBµV/m	---	dBµV/m	dB	---
8398.6	47.2	Average	54.0	6.8	H
8399.8	57.0	Peak	74.0	17.0	V
23909.8	50.6	Peak	74.0	23.4	H
23910.3	41.0	Average	54.0	13.0	H
39962.3	54.5	Peak	74.0	19.5	H
39962.3	47.9	Average	54.0	6.1	V

Radiated Spurious – CH140

Frequency	Level	Detector	Limit	Margin	Polar
MHz	dB μ V/m	---	dB μ V/m	dB	---
8263.9	55.8	Peak	74.0	18.2	H
8265.0	45.0	Average	54.0	9.0	H
11401.5	63.1	Peak	74.0	10.9	H
11401.5	49.2	Average	54.0	4.8	H
11410.5	58.5	Peak	74.0	15.5	H
11410.5	45.0	Average	54.0	9.0	H

1 GHz – 40 GHz, 802.11a, 6Mbps, Chain B**Radiated Spurious – CH100**

Frequency	Level	Detector	Limit	Margin	Polar
MHz	dB μ V/m	---	dB μ V/m	dB	---
8249.3	49.1	Average	54.0	4.9	H
8249.6	60.8	Peak	74.0	13.2	H
11004.5	52.2	Peak	74.0	21.8	V
11004.5	42.0	Average	54.0	12.0	V

Radiated Spurious – CH120

Frequency	Level	Detector	Limit	Margin	Polar
MHz	dB μ V/m	---	dB μ V/m	dB	---
8399.5	48.9	Average	54.0	5.1	H
8401.3	59.8	Peak	74.0	14.2	H
11201.5	57.5	Peak	74.0	16.5	V
11201.5	46.9	Average	54.0	7.1	V

Radiated Spurious – CH140

Frequency	Level	Detector	Limit	Margin	Polar
MHz	dB μ V/m	---	dB μ V/m	dB	---
8550.9	58.4	Peak	68.2	9.8	H
11398.5	54.6	Peak	74.0	19.4	V
11398.5	50.1	Average	54.0	3.9	V

802.11n**1 GHz – 40 GHz, 802.11n20, HT0, Chain A****Radiated Spurious – CH100**

Frequency	Level	Detector	Limit	Margin	Polar
MHz	dB μ V/m	---	dB μ V/m	dB	---
1249.7	45.3	Peak	74.0	28.7	V
1249.7	36.5	Average	54.0	17.5	V
10993.0	58.4	Peak	74.0	15.6	H
10993.0	48.7	Average	54.0	5.3	H
11001.0	49.7	Average	54.0	4.3	H
11001.5	58.5	Peak	74.0	15.5	H

Radiated Spurious – CH120

Frequency	Level	Detector	Limit	Margin	Polar
MHz	dB μ V/m	---	dB μ V/m	dB	---
1249.7	45.9	Peak	74.0	28.1	V
1249.7	36.6	Average	54.0	17.4	V
11194.5	63.2	Peak	74.0	10.8	H
11194.5	50.6	Average	54.0	3.4	H
11202.5	68.1	Peak	74.0	5.9	H
11202.5	51.7	Average	54.0	2.3	H

Radiated Spurious – CH140

Frequency	Level	Detector	Limit	Margin	Polar
MHz	dB μ V/m	---	dB μ V/m	dB	---
1249.7	44.2	Peak	74.0	29.8	V
1249.7	36.5	Average	54.0	17.5	V
11402.0	63.4	Peak	74.0	10.6	H
11402.0	51.1	Average	54.0	2.9	H
11405.5	60.9	Peak	74.0	13.1	H
11405.5	50.2	Average	54.0	3.8	H

1 GHz – 40 GHz, 802.11n20, HT0, Chain B

Radiated Spurious – CH100

Frequency	Level	Detector	Limit	Margin	Polar
MHz	dB μ V/m	---	dB μ V/m	dB	---
8249.9	46.8	Average	54.0	7.2	H
8251.9	59.4	Peak	74.0	14.6	H
10998.5	56.0	Peak	74.0	18.0	V
10998.5	46.6	Average	54.0	7.4	V

Radiated Spurious – CH120

Frequency	Level	Detector	Limit	Margin	Polar
MHz	dB μ V/m	---	dB μ V/m	dB	---
8399.2	46.4	Average	54.0	7.6	H
8400.1	59.2	Peak	74.0	14.8	H
11199.5	56.1	Peak	74.0	17.9	V
11199.5	46.9	Average	54.0	7.1	V

Radiated Spurious – CH140

Frequency	Level	Detector	Limit	Margin	Polar
MHz	dB μ V/m	---	dB μ V/m	dB	---
8550.9	59.7	Peak	68.2	8.5	H
11397.5	52.8	Peak	74.0	21.2	V
11397.5	47.3	Average	54.0	6.7	V

1 GHz – 40 GHz, 802.11n20, HT8, Chain A+B

Radiated Spurious – CH100

Frequency	Level	Detector	Limit	Margin	Polar
MHz	dB μ V/m	---	dB μ V/m	dB	---
8248.7	60.5	Peak	74.0	13.5	H
8250.2	47.1	Average	54.0	6.9	H
10996.0	60.2	Peak	74.0	13.8	H
10996.0	48.2	Average	54.0	5.8	H
11003.5	61.4	Peak	74.0	12.6	H
11003.5	49.0	Average	54.0	5.0	H

Radiated Spurious – CH120

Frequency	Level	Detector	Limit	Margin	Polar
MHz	dB μ V/m	---	dB μ V/m	dB	---
8398.9	59.5	Peak	74.0	14.5	H
8401.3	46.6	Average	54.0	7.4	H
11194.5	60.5	Peak	74.0	13.5	H
11194.5	50.3	Average	54.0	3.7	H
11200.5	63.9	Peak	74.0	10.1	H
11200.5	51.6	Average	54.0	2.4	H

Radiated Spurious – CH140

Frequency	Level	Detector	Limit	Margin	Polar
MHz	dB μ V/m	---	dB μ V/m	dB	---
8550.0	59.3	Peak	68.2	8.9	H
11399.5	62.9	Peak	74.0	11.1	H
11399.5	49.4	Average	54.0	4.6	H

1 GHz – 40 GHz, 802.11n40, HT0, Chain A

Radiated Spurious – CH102

Frequency	Level	Detector	Limit	Margin	Polar
MHz	dB μ V/m	---	dB μ V/m	dB	---
9437.0	56.2	Peak	74.0	17.8	H
9437.0	46.4	Average	54.0	7.6	H
11025.0	55.7	Peak	74.0	18.3	H
11025.0	45.7	Average	54.0	8.3	H

Radiated Spurious – CH118

Frequency	Level	Detector	Limit	Margin	Polar
MHz	dB μ V/m	---	dB μ V/m	dB	---
9456.2	57.2	Peak	74.0	16.8	V
9456.2	45.9	Average	54.0	8.1	H
11180.5	60.1	Peak	74.0	13.9	H
11180.5	48.5	Average	54.0	5.5	H

Radiated Spurious – CH134

Frequency	Level	Detector	Limit	Margin	Polar
MHz	dB μ V/m	---	dB μ V/m	dB	---
9443.7	57.2	Peak	74.0	16.8	V
9443.7	46.5	Average	54.0	7.5	V
11333.5	60.0	Peak	74.0	14.0	H
11333.5	48.2	Average	54.0	5.8	H
11343.5	57.4	Peak	74.0	16.6	H
11343.5	47.9	Average	54.0	6.1	H

1 GHz – 40 GHz, 802.11n40, HT0, Chain B

Radiated Spurious – CH102

Frequency	Level	Detector	Limit	Margin	Polar
MHz	dB μ V/m	---	dB μ V/m	dB	---
9379.2	56.2	Peak	74.0	17.8	H
9379.2	46.5	Average	54.0	7.5	H
11021.5	48.1	Peak	74.0	25.9	V
11021.5	43.4	Average	54.0	10.6	V

Radiated Spurious – CH118

Frequency	Level	Detector	Limit	Margin	Polar
MHz	dB μ V/m	---	dB μ V/m	dB	---
9426.8	55.2	Peak	74.0	18.8	H
9426.8	46.3	Average	54.0	7.7	V
11175.5	51.1	Peak	74.0	22.9	V
11175.5	43.7	Average	54.0	10.3	V

Radiated Spurious – CH134

Frequency	Level	Detector	Limit	Margin	Polar
MHz	dB μ V/m	---	dB μ V/m	dB	---
9398.5	55.7	Peak	74.0	18.3	V
9398.5	46.5	Average	54.0	7.5	H
11340.0	51.2	Peak	74.0	22.8	V
11340.0	43.8	Average	54.0	10.2	V

1 GHz – 40 GHz, 802.11n40, HT8, Chain A+B

Radiated Spurious – CH102

Frequency	Level	Detector	Limit	Margin	Polar
MHz	dB μ V/m	---	dB μ V/m	dB	---
9432.0	55.5	Peak	74.0	18.5	V
9432.0	46.5	Average	54.0	7.5	V
11026.5	55.5	Peak	74.0	18.5	H
11026.5	45.6	Average	54.0	8.4	H

Radiated Spurious – CH118

Frequency	Level	Detector	Limit	Margin	Polar
MHz	dB μ V/m	---	dB μ V/m	dB	---
9439.3	55.6	Peak	74.0	18.4	H
9439.3	46.5	Average	54.0	7.5	H
11166.5	58.0	Peak	74.0	16.0	H
11166.5	47.4	Average	54.0	6.6	H
11179.5	60.5	Peak	74.0	13.5	H
11179.5	48.3	Average	54.0	5.7	H

Radiated Spurious – CH134

Frequency	Level	Detector	Limit	Margin	Polar
MHz	dB μ V/m	---	dB μ V/m	dB	---
9416.5	55.5	Peak	74.0	18.5	H
9416.5	46.1	Average	54.0	7.9	H
11338.5	57.7	Peak	74.0	16.3	H
11338.5	48.3	Average	54.0	5.7	H
11349.0	58.6	Peak	74.0	15.4	H
11349.0	46.5	Average	54.0	7.5	H

802.11ac**1 GHz – 40 GHz, 802.11ac80, VHT0, Chain A****Radiated Spurious – CH106**

Frequency	Level	Detector	Limit	Margin	Polar
MHz	dB μ V/m	---	dB μ V/m	dB	---
8318.4	55.3	Peak	74.0	18.7	V
8318.7	45.1	Average	54.0	8.9	V
11064.0	56.2	Peak	74.0	17.8	H
11064.0	44.3	Average	54.0	9.7	H

Radiated Spurious – CH122

Frequency	Level	Detector	Limit	Margin	Polar
MHz	dB μ V/m	---	dB μ V/m	dB	---
7971.6	57.7	Peak	68.2	10.5	V
11210.5	54.7	Peak	74.0	19.3	H
11210.5	45.2	Average	54.0	8.8	H

Radiated Spurious – CH138

Frequency	Level	Detector	Limit	Margin	Polar
MHz	dB μ V/m	---	dB μ V/m	dB	---
8334.2	44.5	Average	54.0	9.5	H
8335.9	56.0	Peak	74.0	18.0	V
11377.5	53.4	Peak	74.0	20.6	H
11377.5	44.5	Average	54.0	9.5	H

1 GHz – 40 GHz, 802.11ac80, VHT0, Chain B

Radiated Spurious – CH106

Frequency	Level	Detector	Limit	Margin	Polar
MHz	dB μ V/m	---	dB μ V/m	dB	---
8256.6	54.9	Peak	74.0	19.1	V
8257.2	45.1	Average	54.0	8.9	V
11067.5	47.9	Peak	74.0	26.1	V
11067.5	41.1	Average	54.0	12.9	V

Radiated Spurious – CH122

Frequency	Level	Detector	Limit	Margin	Polar
MHz	dB μ V/m	---	dB μ V/m	dB	---
8314.3	45.0	Average	54.0	9.0	H
8318.1	55.0	Peak	74.0	19.0	V
11208.5	48.6	Peak	74.0	25.4	V
11208.5	42.5	Average	54.0	11.5	V

Radiated Spurious – CH138

Frequency	Level	Detector	Limit	Margin	Polar
MHz	dB μ V/m	---	dB μ V/m	dB	---
8252.5	45.0	Average	54.0	9.0	V
8254.0	55.2	Peak	74.0	18.8	H
11394.0	51.9	Peak	74.0	22.1	V
11394.0	43.3	Average	54.0	10.7	V

1 GHz – 40 GHz, 802.11ac80, VHT0, Chain A+B

Radiated Spurious – CH106

Frequency	Level	Detector	Limit	Margin	Polar
MHz	dB μ V/m	---	dB μ V/m	dB	---
8247.3	54.9	Peak	74.0	19.1	V
8248.1	44.6	Average	54.0	9.4	V
11060.5	57.6	Peak	74.0	16.4	V
11060.5	45.3	Average	54.0	8.7	V

Radiated Spurious – CH122

Frequency	Level	Detector	Limit	Margin	Polar
MHz	dB μ V/m	---	dB μ V/m	dB	---
8255.4	45.0	Average	54.0	9.0	V
8256.3	56.2	Peak	74.0	17.8	V
11237.5	55.1	Peak	74.0	18.9	H
11237.5	42.7	Average	54.0	11.3	H

Radiated Spurious – CH138

Frequency	Level	Detector	Limit	Margin	Polar
MHz	dB μ V/m	---	dB μ V/m	dB	---
8184.3	55.4	Peak	74.0	18.6	V
8184.3	45.1	Average	54.0	8.9	V
11391.5	54.2	Peak	74.0	19.8	H
11391.5	43.0	Average	54.0	11.0	H

1 GHz – 40 GHz, 802.11ac160, VHT0, Chain A

Radiated Spurious – CH114

Frequency	Level	Detector	Limit	Margin	Polar
MHz	dB μ V/m	---	dB μ V/m	dB	---
1249.7	45.4	Peak	74.0	28.6	V
1249.7	36.8	Average	54.0	17.2	V
11153.5	48.5	Peak	74.0	25.5	H
11153.5	41.0	Average	54.0	13.0	H

1 GHz – 40 GHz, 802.11ac160, VHT0, Chain B

Radiated Spurious – CH114

Frequency	Level	Detector	Limit	Margin	Polar
MHz	dB μ V/m	---	dB μ V/m	dB	---
1249.7	45.2	Peak	74.0	28.8	V
1249.7	36.2	Average	54.0	17.8	V
10499.5	49.2	Peak	68.2	19.0	V

1 GHz – 40 GHz, 802.11ac160, VHT0, Chain A+B

Radiated Spurious – CH114

Frequency	Level	Detector	Limit	Margin	Polar
MHz	dB μ V/m	---	dB μ V/m	dB	---
1249.7	45.1	Peak	74.0	28.9	V
1249.7	36.2	Average	54.0	17.8	V
11127.5	47.1	Peak	74.0	26.9	H
11127.5	40.1	Average	54.0	13.9	V

802.11ax/be**1 GHz – 40 GHz, 802.11ax/be20, MCS0, Chain A****Radiated Spurious – CH100**

Frequency	Level	Detector	Limit	Margin	Polar
MHz	dB μ V/m	---	dB μ V/m	dB	---
8237.6	46.3	Average	54.0	7.7	H
8237.6	60.0	Peak	74.0	14.0	H
10983.0	42.7	Average	54.0	11.3	H
10983.5	57.8	Peak	74.0	16.2	H

Radiated Spurious – CH120

Frequency	Level	Detector	Limit	Margin	Polar
MHz	dB μ V/m	---	dB μ V/m	dB	---
8387.0	63.1	Peak	74.0	10.9	H
8387.3	51.2	Average	54.0	2.8	H
11183.0	56.4	Peak	74.0	17.6	H
11183.0	44.6	Average	54.0	9.4	H

Radiated Spurious – CH140

Frequency	Level	Detector	Limit	Margin	Polar
MHz	dB μ V/m	---	dB μ V/m	dB	---
8537.2	60.8	Peak	68.2	7.4	H
11382.0	59.5	Peak	74.0	14.5	H
11382.0	40.9	Average	54.0	13.1	H

1 GHz – 40 GHz, 802.11ax/be20, MCS0, Chain B

Radiated Spurious – CH100

Frequency	Level	Detector	Limit	Margin	Polar
MHz	dB μ V/m	---	dB μ V/m	dB	---
8237.3	61.2	Peak	74.0	12.8	H
8237.6	48.8	Average	54.0	5.2	H
10500.0	48.8	Peak	68.2	19.4	V
10983.5	49.8	Peak	74.0	24.2	V
10983.5	38.5	Average	54.0	15.5	V

Radiated Spurious – CH120

Frequency	Level	Detector	Limit	Margin	Polar
MHz	dB μ V/m	---	dB μ V/m	dB	---
8386.1	47.5	Average	54.0	6.5	H
8387.0	62.0	Peak	74.0	12.0	H
11183.0	49.8	Peak	74.0	24.2	H
11183.0	40.0	Average	54.0	14.0	V

Radiated Spurious – CH140

Frequency	Level	Detector	Limit	Margin	Polar
MHz	dB μ V/m	---	dB μ V/m	dB	---
8537.5	61.2	Peak	68.2	7.0	H
11382.5	49.8	Peak	74.0	24.2	V
11382.5	39.5	Average	54.0	14.5	V

1 GHz – 40 GHz, 802.11ax/be20, MCS0, Chain A+B

Radiated Spurious – CH100

Frequency	Level	Detector	Limit	Margin	Polar
MHz	dB μ V/m	---	dB μ V/m	dB	---
8236.8	48.4	Average	54.0	5.6	H
8238.2	62.4	Peak	74.0	11.6	H
10983.0	53.8	Peak	74.0	20.2	V
10983.5	43.3	Average	54.0	10.7	V

Radiated Spurious – CH120

Frequency	Level	Detector	Limit	Margin	Polar
MHz	dB μ V/m	---	dB μ V/m	dB	---
8386.7	48.9	Average	54.0	5.1	H
8387.0	62.8	Peak	74.0	11.2	H
11183.0	58.0	Peak	74.0	16.0	H
11183.0	44.4	Average	54.0	9.6	H

Radiated Spurious – CH140

Frequency	Level	Detector	Limit	Margin	Polar
MHz	dB μ V/m	---	dB μ V/m	dB	---
8537.2	63.8	Peak	68.2	4.4	H
11383.5	54.3	Peak	74.0	19.7	H
11383.5	43.4	Average	54.0	10.6	H

1 GHz – 40 GHz, 802.11ax/be40, MCS0, Chain A

Radiated Spurious – CH102

Frequency	Level	Detector	Limit	Margin	Polar
MHz	dB μ V/m	---	dB μ V/m	dB	---
8023.0	54.7	Peak	68.2	13.5	H
11001.0	53.9	Peak	74.0	20.1	H
11001.0	42.5	Average	54.0	11.5	H

Radiated Spurious – CH118

Frequency	Level	Detector	Limit	Margin	Polar
MHz	dB μ V/m	---	dB μ V/m	dB	---
8370.3	57.5	Peak	74.0	16.5	H
8371.2	46.8	Average	54.0	7.2	H
11160.0	54.2	Peak	74.0	19.8	H
11160.0	43.8	Average	54.0	10.2	H

Radiated Spurious – CH134

Frequency	Level	Detector	Limit	Margin	Polar
MHz	dB μ V/m	---	dB μ V/m	dB	---
7974.3	57.0	Peak	68.2	11.2	H
11320.5	56.1	Peak	74.0	17.9	H
11320.5	44.1	Average	54.0	9.9	H

1 GHz – 40 GHz, 802.11ax/be40, MCS0, Chain B

Radiated Spurious – CH102

Frequency	Level	Detector	Limit	Margin	Polar
MHz	dB μ V/m	---	dB μ V/m	dB	---
8250.2	49.8	Average	54.0	4.2	H
8250.5	60.7	Peak	74.0	13.3	H
11000.5	50.0	Peak	74.0	24.0	V
11000.5	39.4	Average	54.0	14.6	V

Radiated Spurious – CH118

Frequency	Level	Detector	Limit	Margin	Polar
MHz	dB μ V/m	---	dB μ V/m	dB	---
8369.2	60.5	Peak	74.0	13.5	H
8369.5	48.2	Average	54.0	5.8	H
11160.0	38.1	Average	54.0	15.9	H
11160.5	48.9	Peak	74.0	25.1	V

Radiated Spurious – CH134

Frequency	Level	Detector	Limit	Margin	Polar
MHz	dB μ V/m	---	dB μ V/m	dB	---
8489.6	59.5	Peak	74.0	14.5	H
8491.1	49.0	Average	54.0	5.0	H
11321.5	51.5	Peak	74.0	22.5	V
11321.5	38.2	Average	54.0	15.8	V

1 GHz – 40 GHz, 802.11ax/be40, MCS0, Chain A+B

Radiated Spurious – CH102

Frequency	Level	Detector	Limit	Margin	Polar
MHz	dB μ V/m	---	dB μ V/m	dB	---
8250.5	49.6	Average	54.0	4.4	H
8250.8	63.0	Peak	74.0	11.0	H
11001.0	58.1	Peak	74.0	15.9	H
11001.0	42.0	Average	54.0	12.0	H

Radiated Spurious – CH118

Frequency	Level	Detector	Limit	Margin	Polar
MHz	dB μ V/m	---	dB μ V/m	dB	---
8369.8	59.9	Peak	74.0	14.1	H
8369.8	49.1	Average	54.0	4.9	H
11160.0	57.7	Peak	74.0	16.3	H
11160.0	43.7	Average	54.0	10.3	H

Radiated Spurious – CH134

Frequency	Level	Detector	Limit	Margin	Polar
MHz	dB μ V/m	---	dB μ V/m	dB	---
8491.1	60.6	Peak	74.0	13.4	H
8491.1	49.5	Average	54.0	4.5	H
11320.5	57.1	Peak	74.0	16.9	V
11320.5	41.4	Average	54.0	12.6	V

1 GHz – 40 GHz, 802.11ax/be80, MCS0, Chain A

Radiated Spurious – CH106

Frequency	Level	Detector	Limit	Margin	Polar
MHz	dB μ V/m	---	dB μ V/m	dB	---
8263.0	59.1	Peak	74.0	14.9	H
8263.3	46.4	Average	54.0	7.6	H
11017.5	53.8	Peak	74.0	20.2	H
11017.5	41.9	Average	54.0	12.1	H

Radiated Spurious – CH122

Frequency	Level	Detector	Limit	Margin	Polar
MHz	dB μ V/m	---	dB μ V/m	dB	---
8382.6	61.0	Peak	74.0	13.0	H
8382.9	47.6	Average	54.0	6.4	H
11177.5	57.9	Peak	74.0	16.1	H
11177.5	44.3	Average	54.0	9.7	H

Radiated Spurious – CH138

Frequency	Level	Detector	Limit	Margin	Polar
MHz	dB μ V/m	---	dB μ V/m	dB	---
7981.8	57.5	Peak	68.2	10.7	V
11337.0	56.1	Peak	74.0	17.9	H
11337.0	44.8	Average	54.0	9.2	H

1 GHz – 40 GHz, 802.11ax/be80, MCS0, Chain B

Radiated Spurious – CH106

Frequency	Level	Detector	Limit	Margin	Polar
MHz	dB μ V/m	---	dB μ V/m	dB	---
8263.3	49.4	Average	54.0	4.6	H
8263.6	62.9	Peak	74.0	11.1	H
11017.0	51.7	Peak	74.0	22.3	V
11017.0	40.3	Average	54.0	13.7	V

Radiated Spurious – CH122

Frequency	Level	Detector	Limit	Margin	Polar
MHz	dB μ V/m	---	dB μ V/m	dB	---
8382.3	61.1	Peak	74.0	12.9	H
8382.3	48.0	Average	54.0	6.0	H
11177.0	55.7	Peak	74.0	18.3	V
11177.0	43.5	Average	54.0	10.5	V

Radiated Spurious – CH138

Frequency	Level	Detector	Limit	Margin	Polar
MHz	dB μ V/m	---	dB μ V/m	dB	---
8503.0	61.3	Peak	68.2	6.9	H
11337.5	50.7	Peak	74.0	23.3	V
11337.5	41.2	Average	54.0	12.8	V

1 GHz – 40 GHz, 802.11ax/be80, MCS0, Chain A+B

Radiated Spurious – CH106

Frequency	Level	Detector	Limit	Margin	Polar
MHz	dB μ V/m	---	dB μ V/m	dB	---
8262.7	48.8	Average	54.0	5.2	H
8263.9	62.2	Peak	74.0	11.8	H
11017.0	54.5	Peak	74.0	19.5	V
11017.0	44.0	Average	54.0	10.0	V

Radiated Spurious – CH122

Frequency	Level	Detector	Limit	Margin	Polar
MHz	dB μ V/m	---	dB μ V/m	dB	---
8382.3	63.2	Peak	74.0	10.8	H
8382.3	49.8	Average	54.0	4.2	H
11176.5	57.6	Peak	74.0	16.4	V
11176.5	43.8	Average	54.0	10.2	V

Radiated Spurious – CH138

Frequency	Level	Detector	Limit	Margin	Polar
MHz	dB μ V/m	---	dB μ V/m	dB	---
8504.2	62.0	Peak	68.2	6.2	H
11337.0	58.3	Peak	74.0	15.7	H
11337.0	44.0	Average	54.0	10.0	H

1 GHz – 40 GHz, 802.11ax/be160, MCS0, Chain A

Radiated Spurious – CH114

Frequency	Level	Detector	Limit	Margin	Polar
MHz	dB μ V/m	---	dB μ V/m	dB	---
8275.8	61.0	Peak	74.0	13.0	H
8275.8	47.7	Average	54.0	6.3	H
11034.0	52.8	Peak	74.0	21.2	H
11034.0	42.2	Average	54.0	11.8	H

1 GHz – 40 GHz, 802.11ax/be160, MCS0, Chain B

Radiated Spurious – CH114

Frequency	Level	Detector	Limit	Margin	Polar
MHz	dB μ V/m	---	dB μ V/m	dB	---
8275.5	61.5	Peak	74.0	12.5	H
8276.1	48.2	Average	54.0	5.8	H
11033.0	39.8	Average	54.0	14.2	V
11034.0	52.6	Peak	74.0	21.4	V

1 GHz – 40 GHz, 802.11ax/be160, MCS0, Chain A+B

Radiated Spurious – CH114

Frequency	Level	Detector	Limit	Margin	Polar
MHz	dB μ V/m	---	dB μ V/m	dB	---
8275.5	62.9	Peak	74.0	11.1	H
8275.5	48.6	Average	54.0	5.4	H
11033.5	57.2	Peak	74.0	16.8	H
11033.5	41.9	Average	54.0	12.1	H

B.3 Test Results Screenshots

B.3.1 26dB Bandwidth

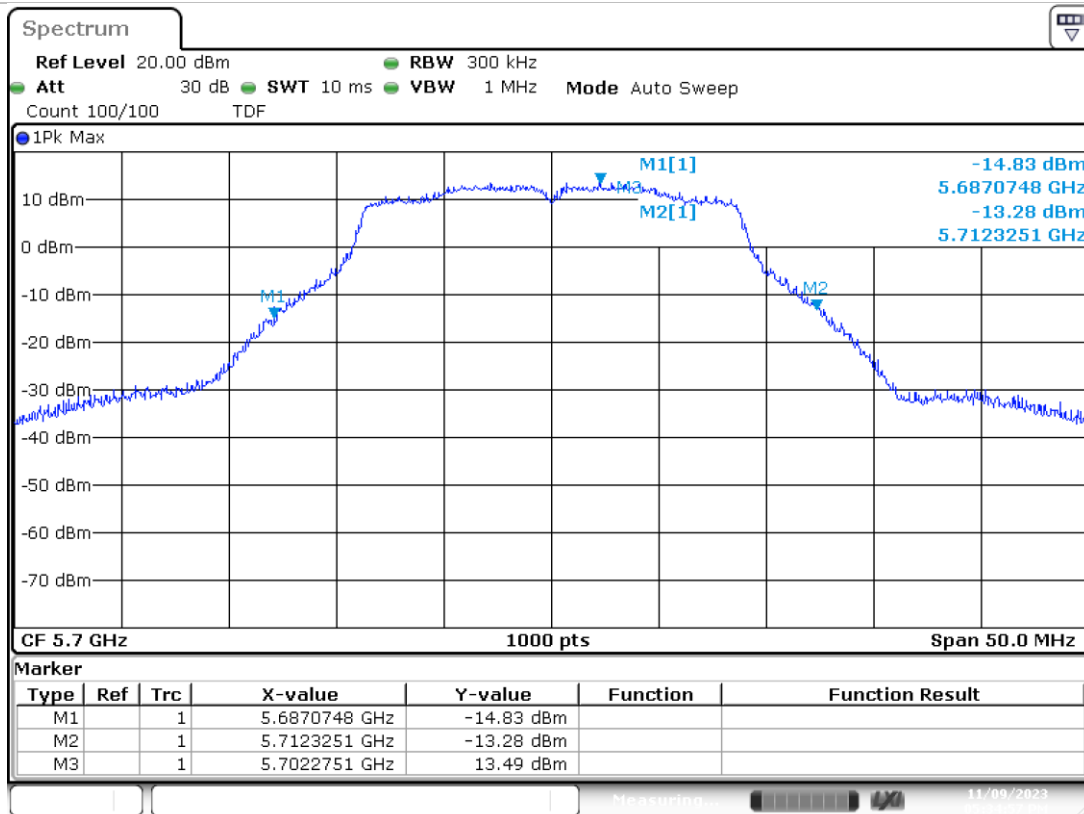

SISO A-802.11n20-CH140-5700MHz-HT0

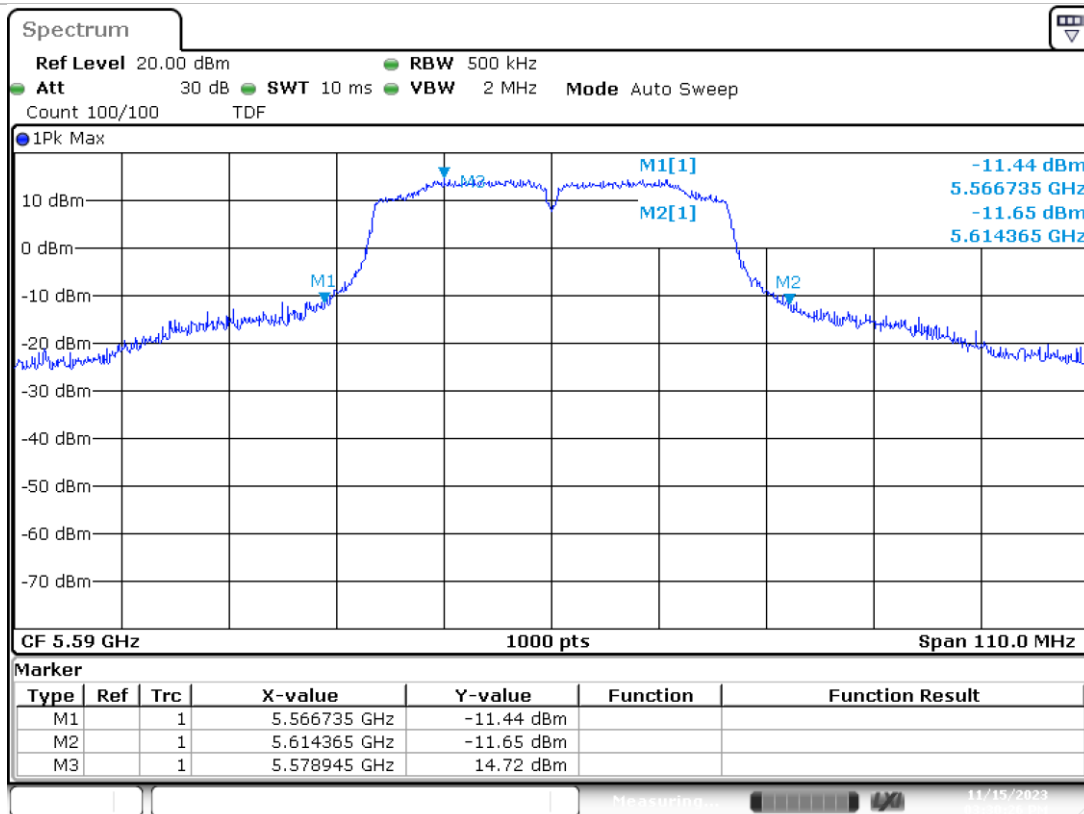

SISO A-802.11n40-CH118-5590 MHz -HT0

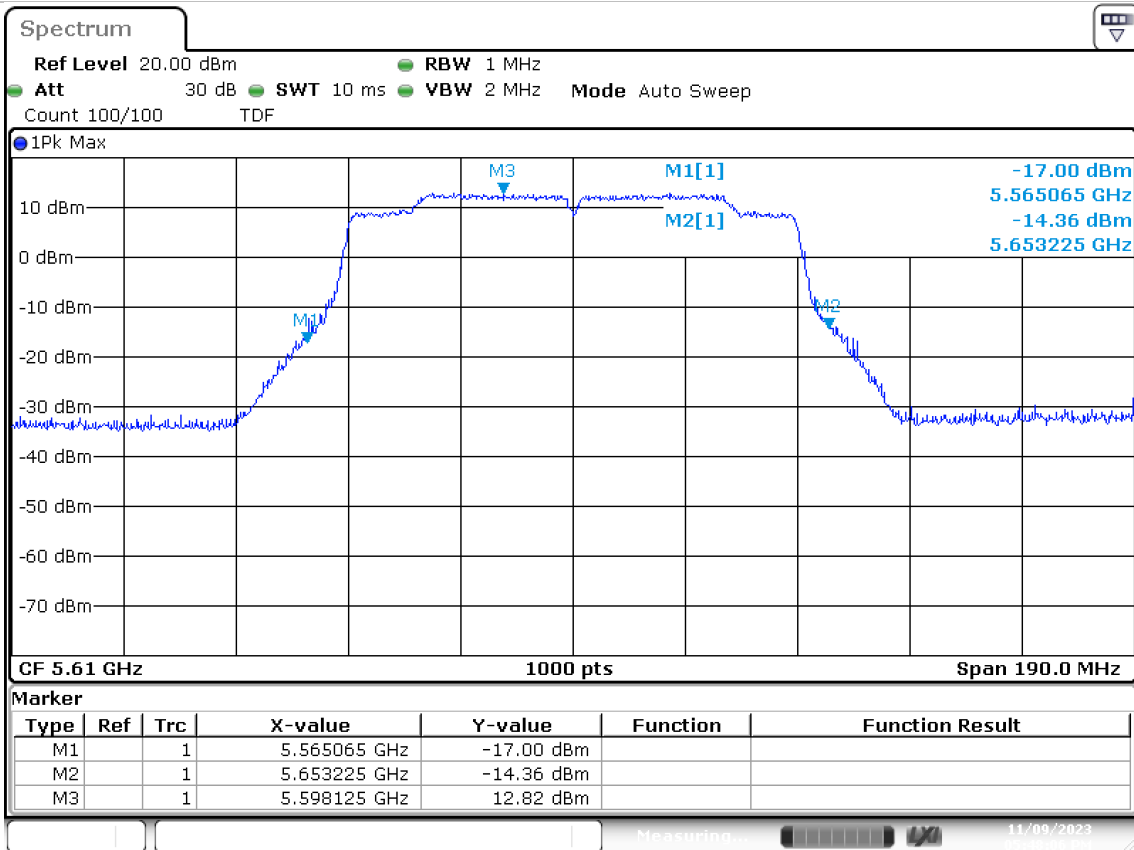

SISO A-802.11ac80-CH122-5610 MHz -VHT0

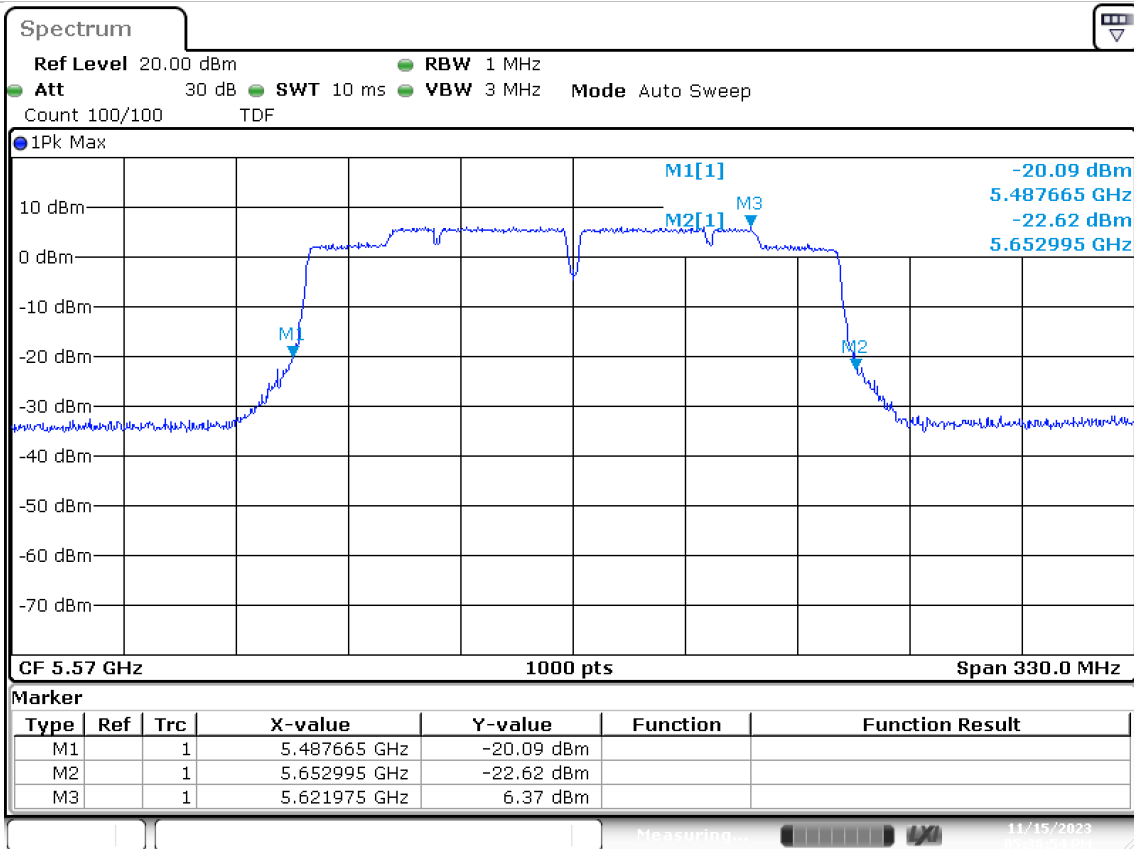

MIMO A-802.11ac160-CH114-5570 MHz -VHT0

B.3.2 99% Bandwidth

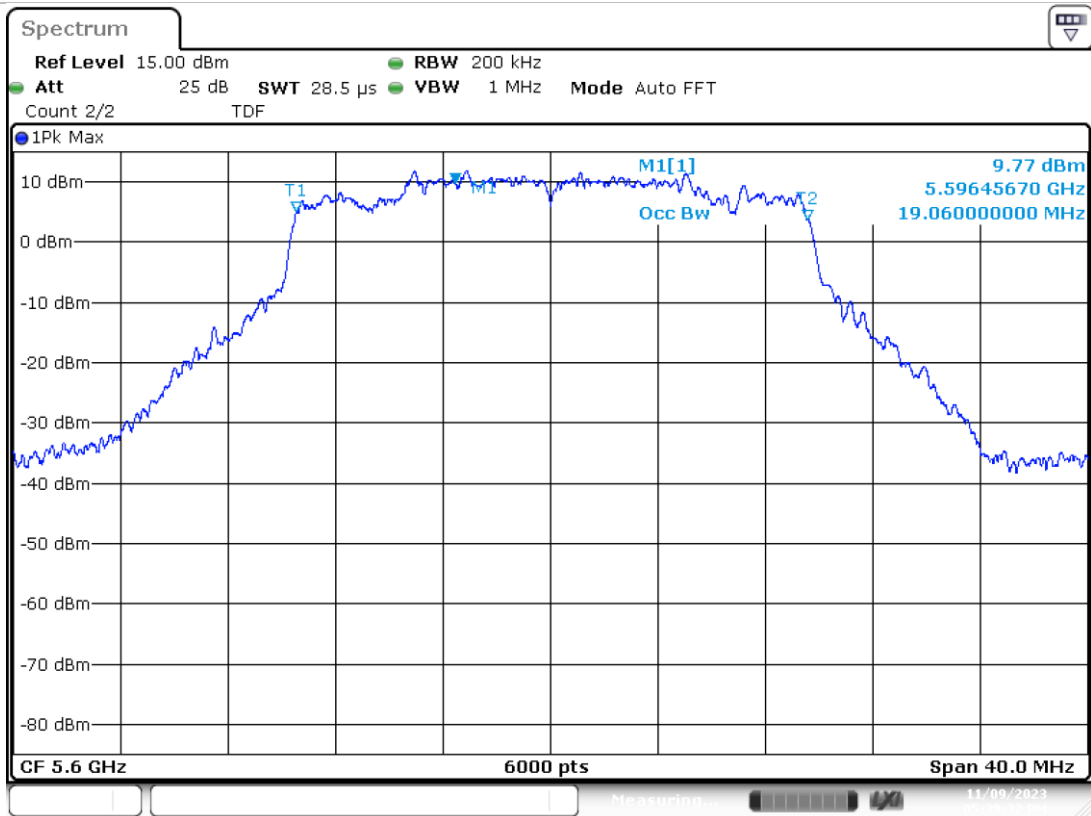

SISO A-802.11ax/be20-CH120-5600MHz-MCS0

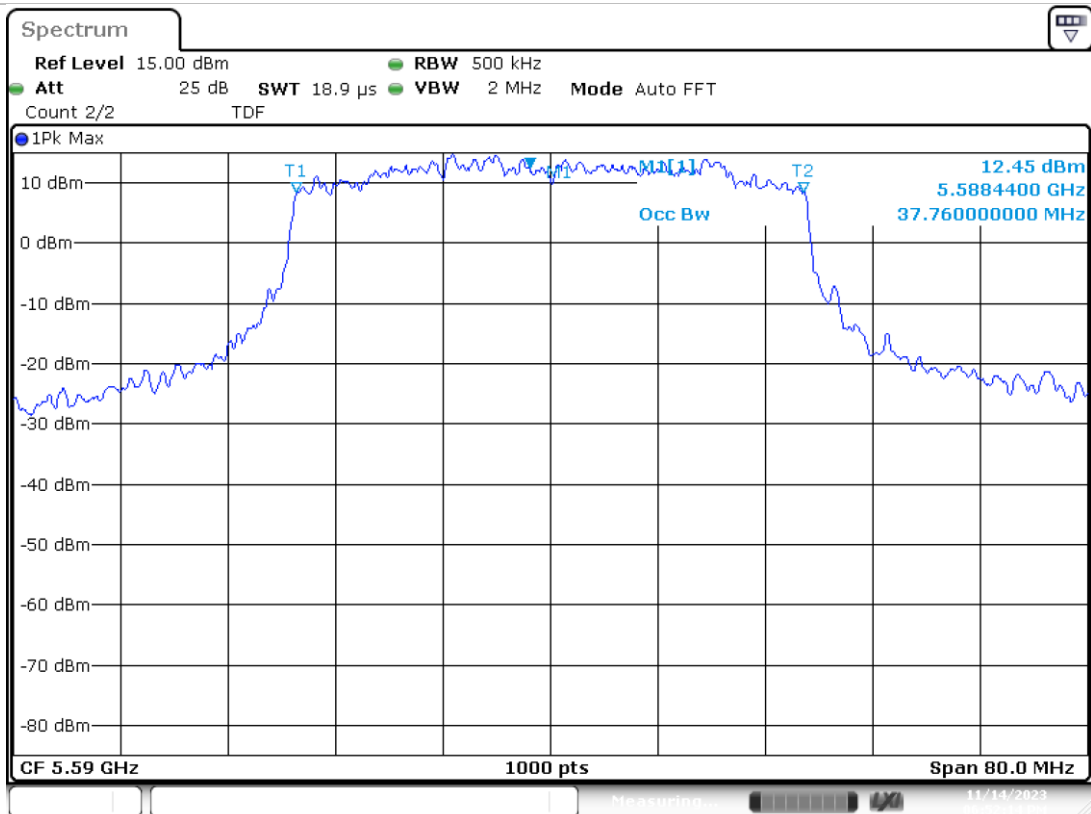

SISO B-802.11ax/be40-CH118-5590 MHz -MCS0

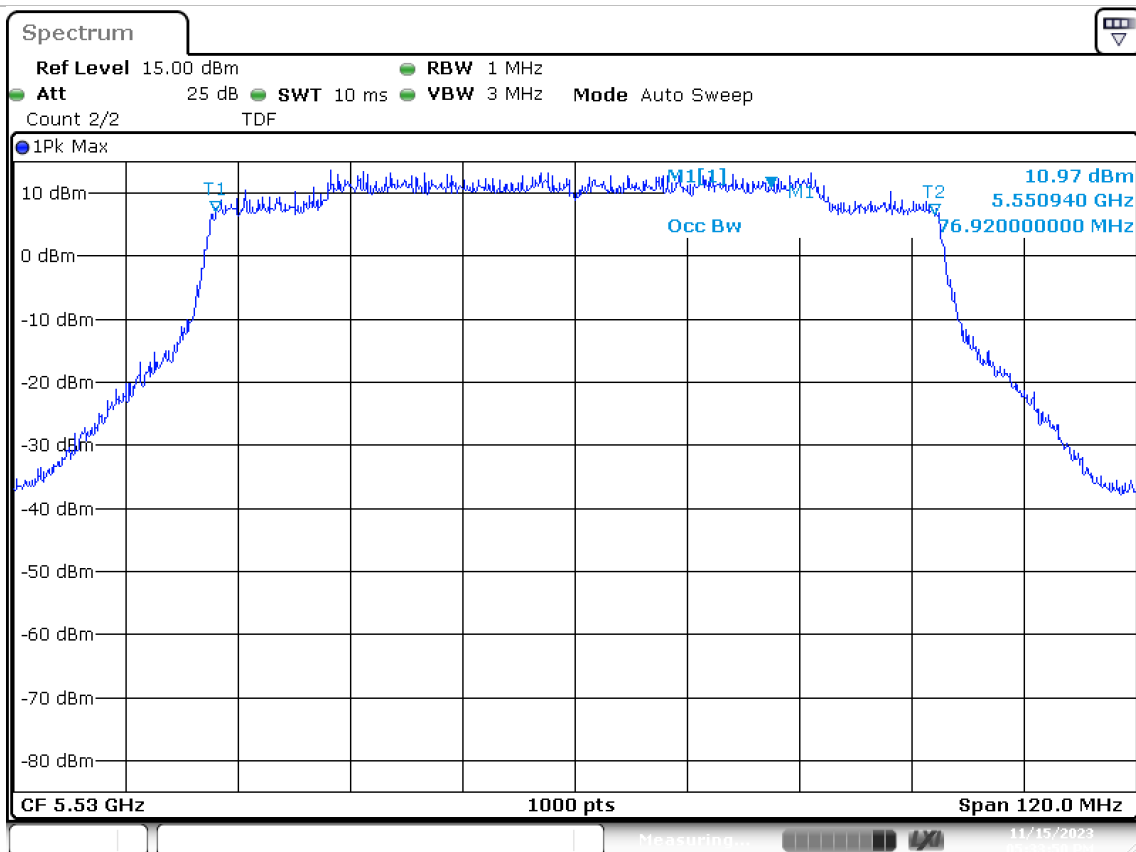

MIMO A-802.11ax/be80-CH106-5530 MHz -MCS0

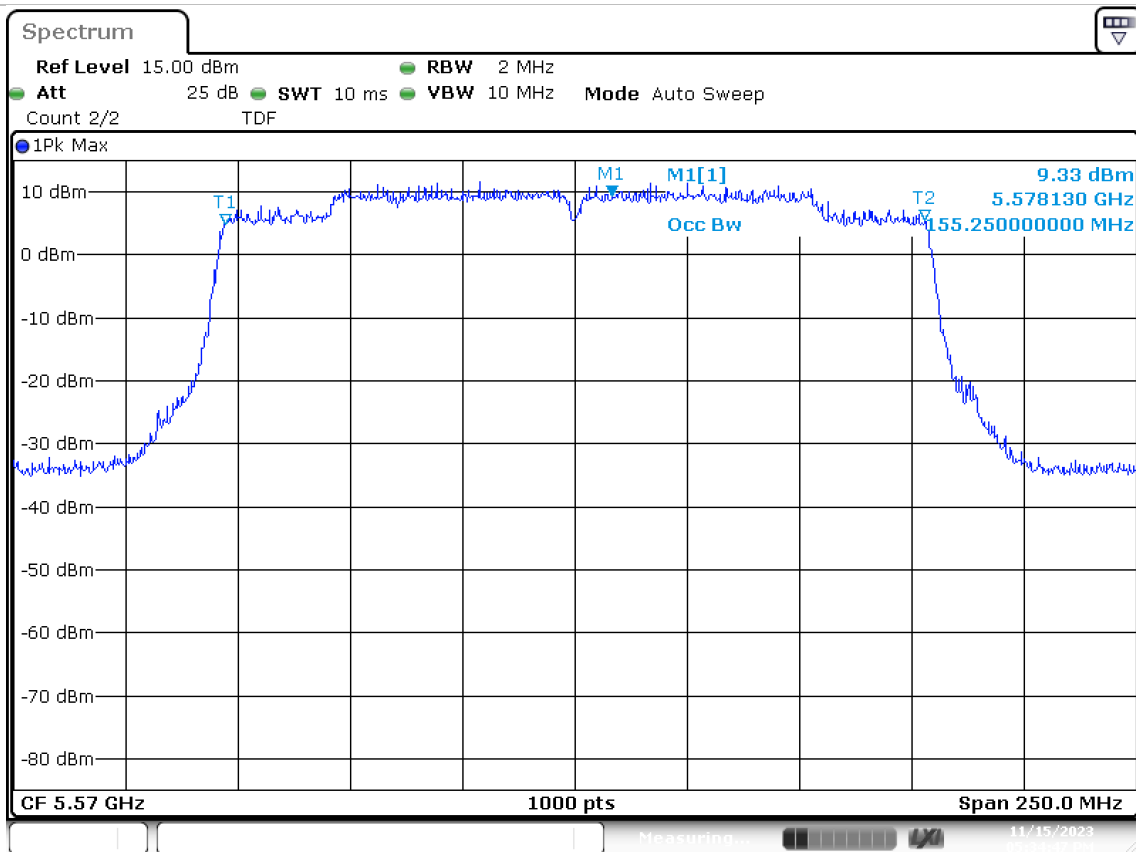

MIMO A-802.11ax/be160-CH114-5570MHz-MCS0

B.3.3 Maximum Output Power & Maximum power spectral Density





MIMO A-802.11ax/be160-Ch114-5570MHz-MCS0

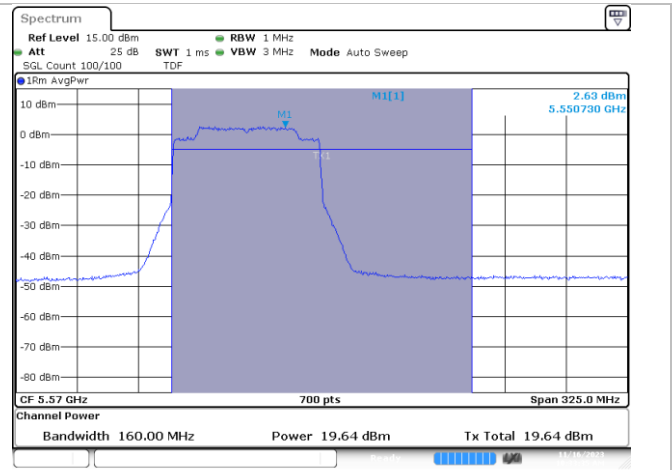

MIMO B-802.11ax/be160-Ch114-5570MHz-MCS0

B.3.4 Undesirable emission limits : out of band (Conducted)

SISO A

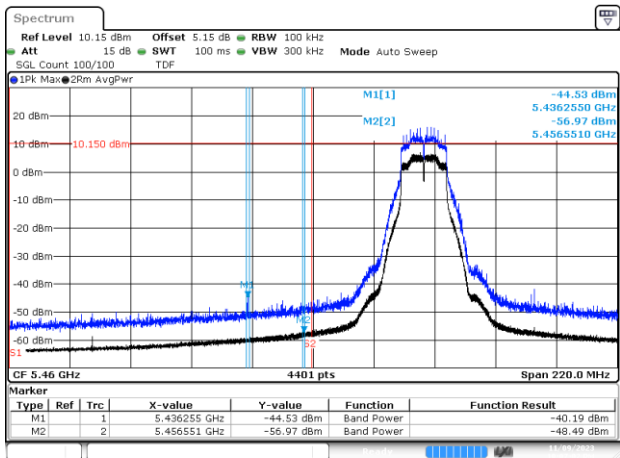

BE-R-LOW, SISO-A, 802.11a20-6Mbps, Ch100

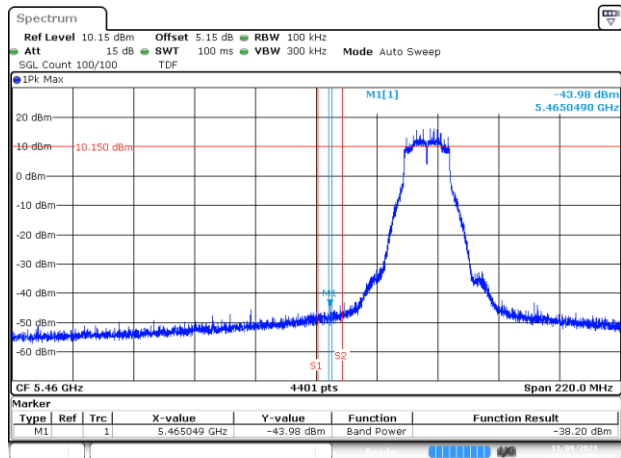

BE-NR-LOW, SISO-A, 802.11a20-6Mbps, Ch100

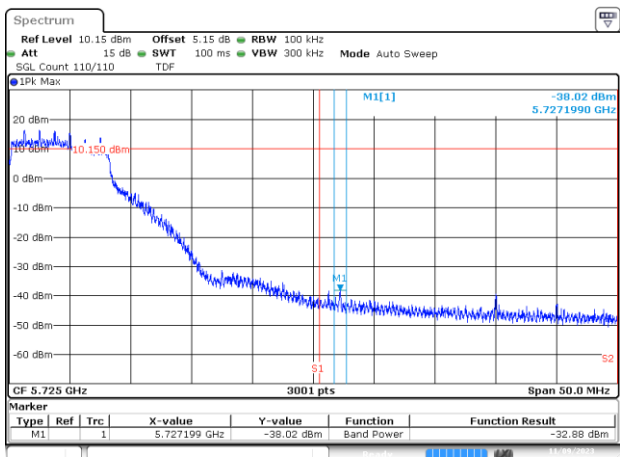

BE-NR-HIGH, SISO-A, 802.11a20-6Mbps, Ch140

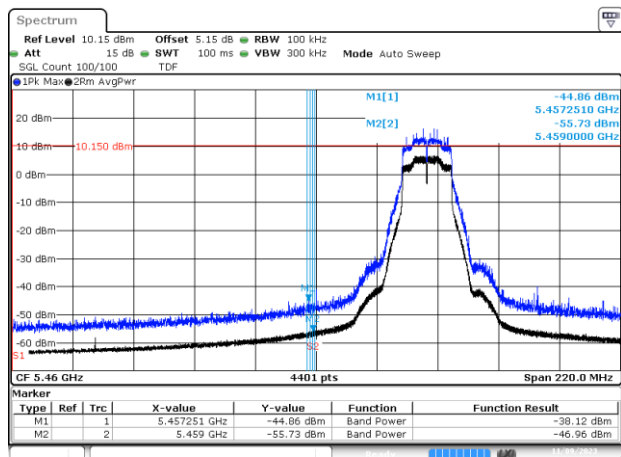

BE-R-LOW, SISO-A, 802.11n20-HT0, Ch100

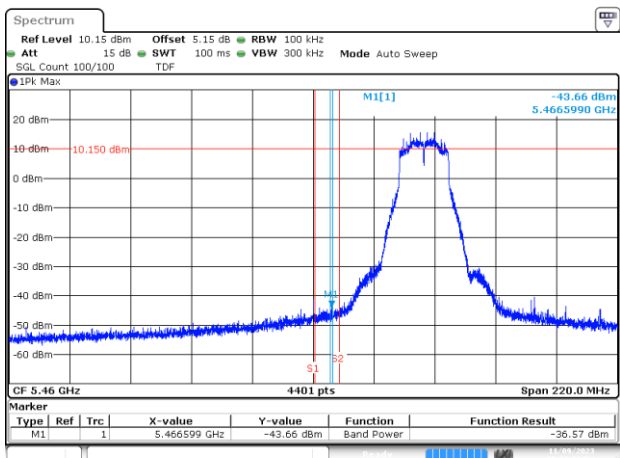

BE-NR-LOW, SISO-A, 802.11n20-HT0, Ch100

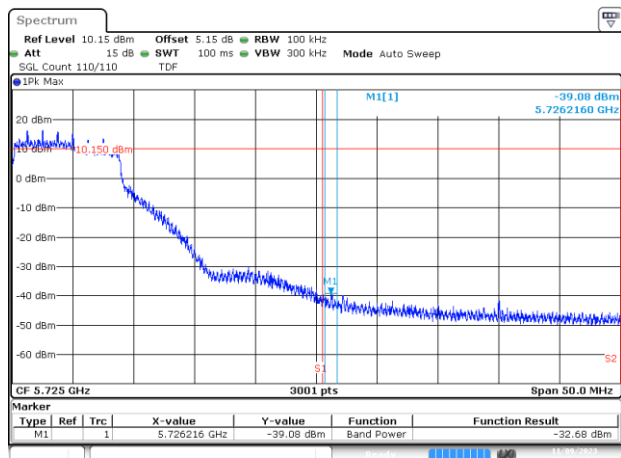

BE-NR-HIGH, SISO-A, 802.11n20-HT0, Ch140

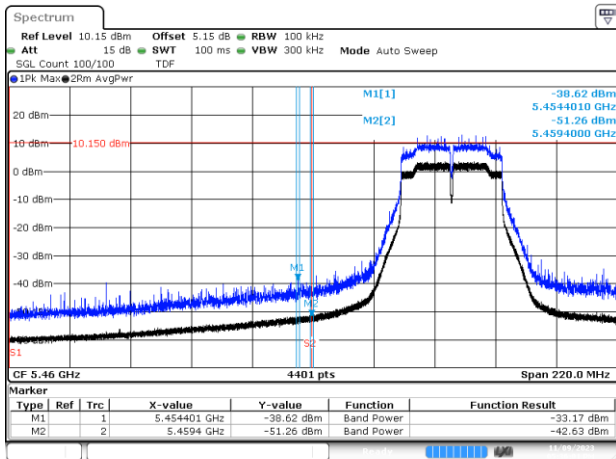

BE-R-LOW, SISO-A, 802.11n40-HT0, Ch102

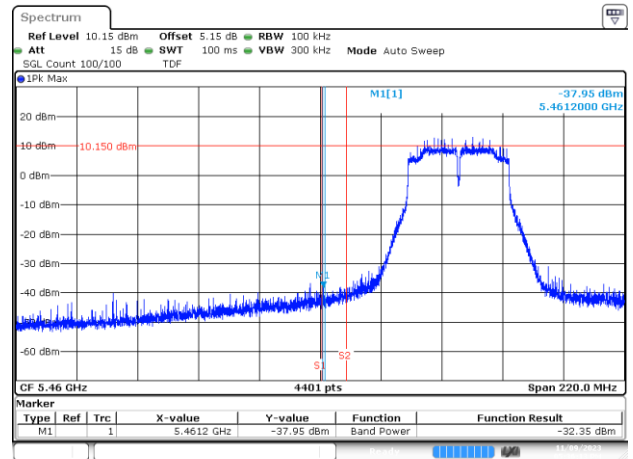

BE-NR-LOW, SISO-A, 802.11n40-HT0, Ch102

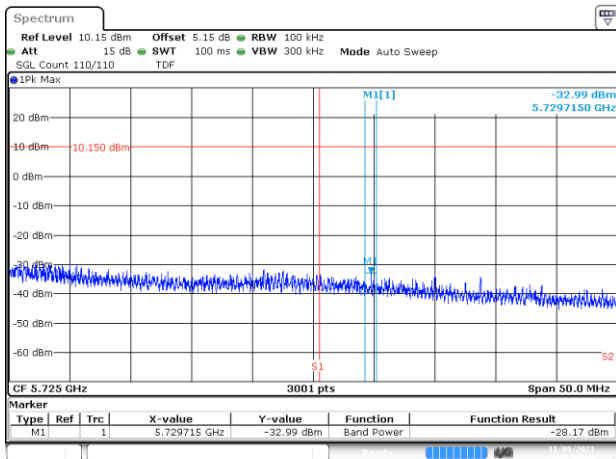

BE-NR-HIGH, SISO-A, 802.11n40-HT0, Ch134

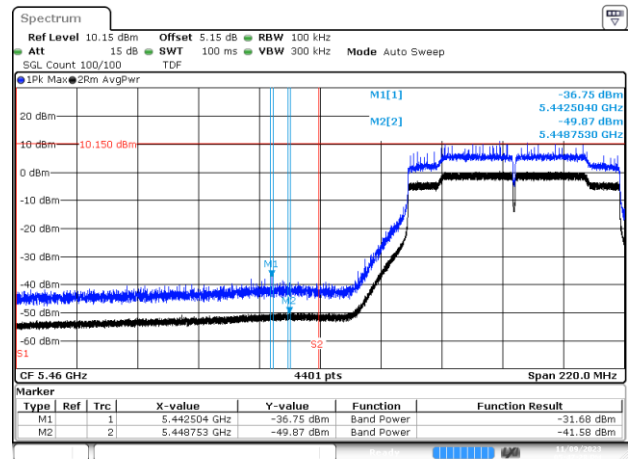

BE-R-LOW, SISO-A, 802.11ac80-VHT0, Ch106

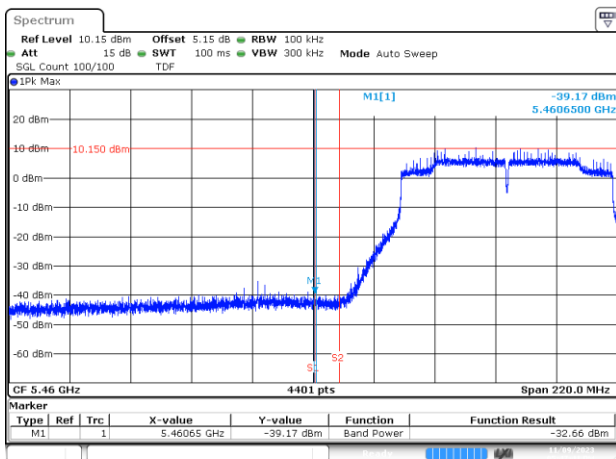

BE-NR-LOW, SISO-A, 802.11ac80-VHT0, Ch106

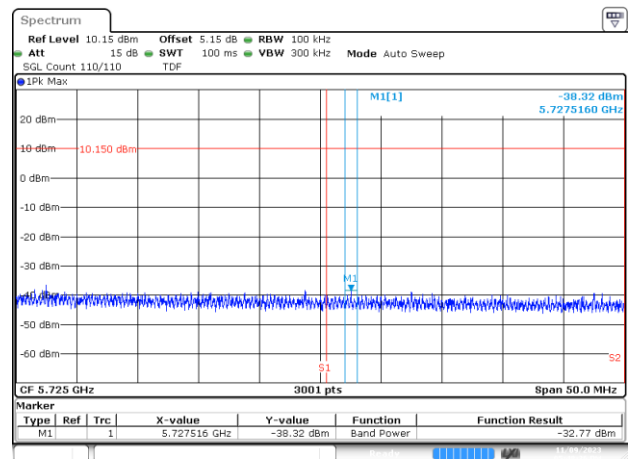

BE-NR-HIGH, SISO-A, 802.11ac80-VHT0, Ch122

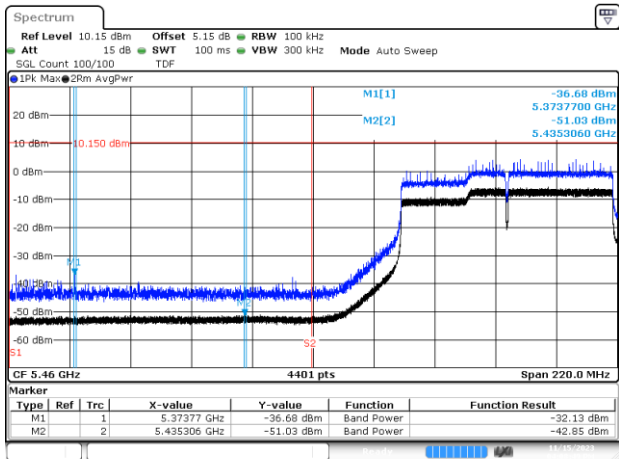

BE-R-LOW, SISO-A, 802.11ac160-VHT0, Ch114

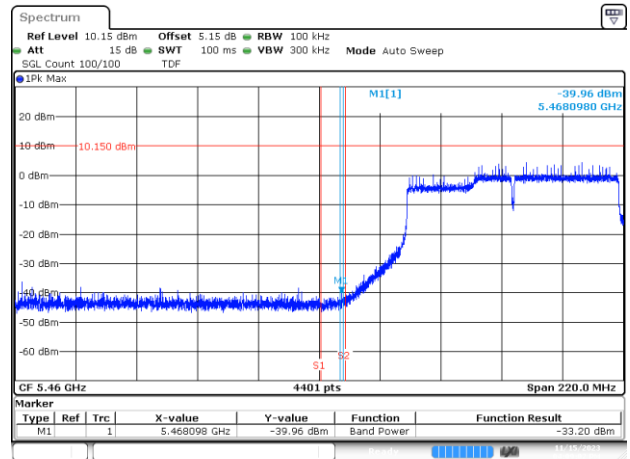

BE-NR-LOW, SISO-A, 802.11ac160-VHT0, Ch114

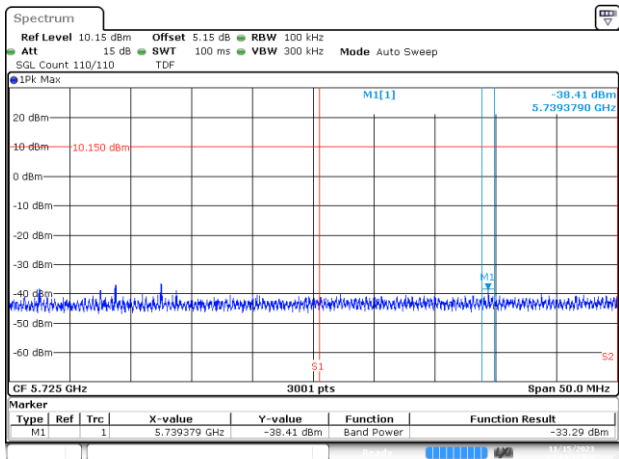

BE-NR-HIGH, SISO-A, 802.11ac160-VHT0, Ch114

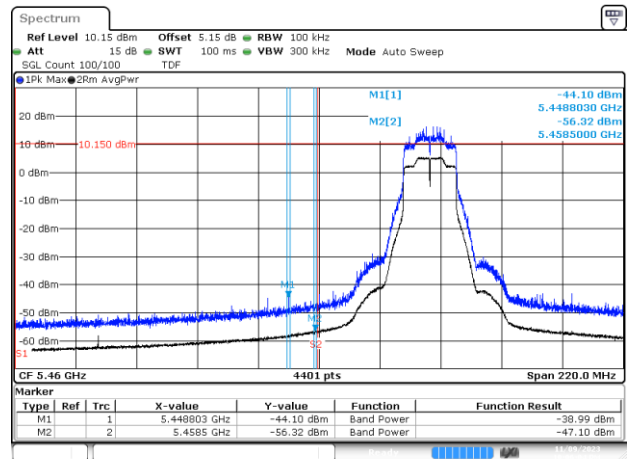

BE-R-LOW, SISO-A, 802.11ax/be20-MCS0, Ch100

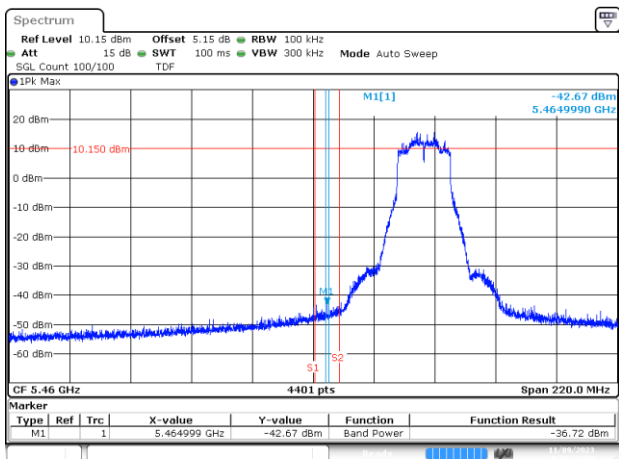

BE-NR-LOW, SISO-A, 802.11ax/be20-MCS0, Ch100

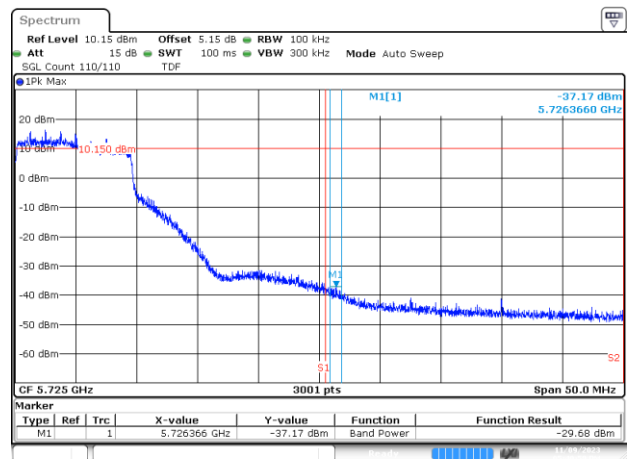

BE-NR-HIGH, SISO-A, 802.11ax/be20-MCS0, Ch140

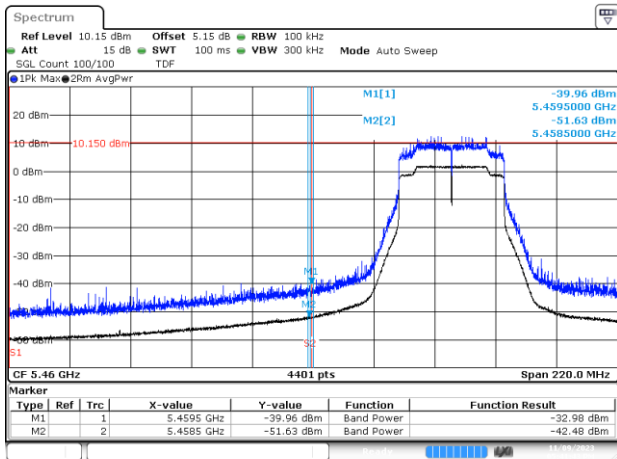

BE-R-LOW, SISO-A, 802.11ax/be40-MCS0, Ch102

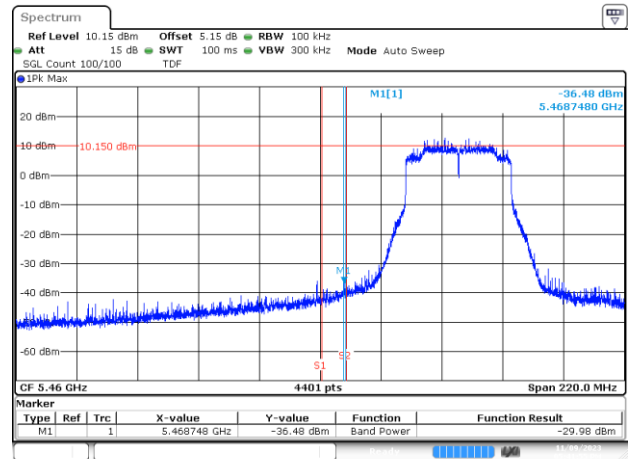

BE-NR-LOW, SISO-A, 802.11ax/be40-MCS0, Ch102

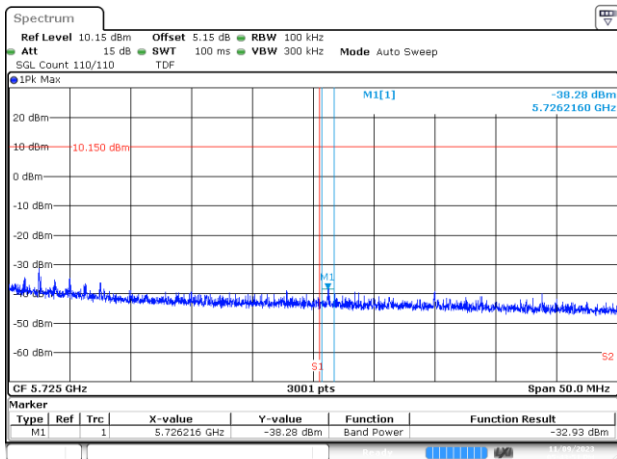

BE-NR-HIGH, SISO-A, 802.11ax/be40-MCS0, Ch134

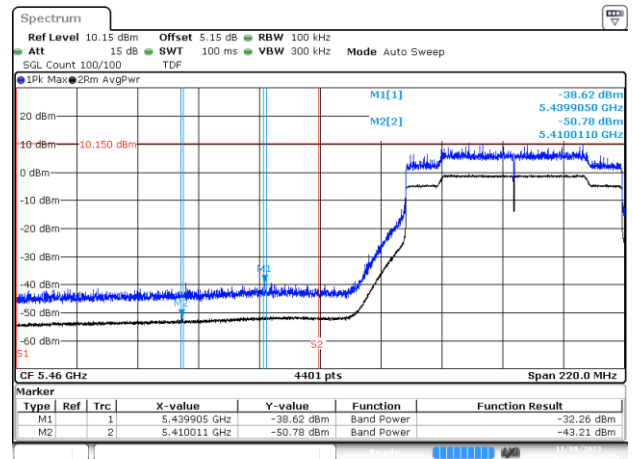

BE-R-LOW, SISO-A, 802.11ax/be80-MCS0, Ch106

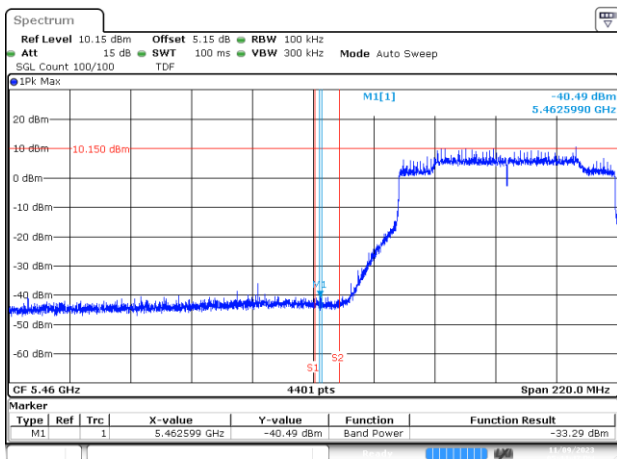

BE-NR-LOW, SISO-A, 802.11ax/be80-MCS0, Ch106

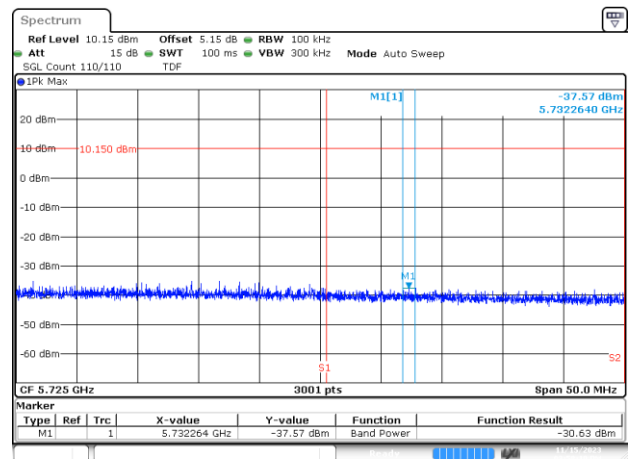

BE-NR-HIGH, SISO-A, 802.11ax/be80-MCS0, Ch122

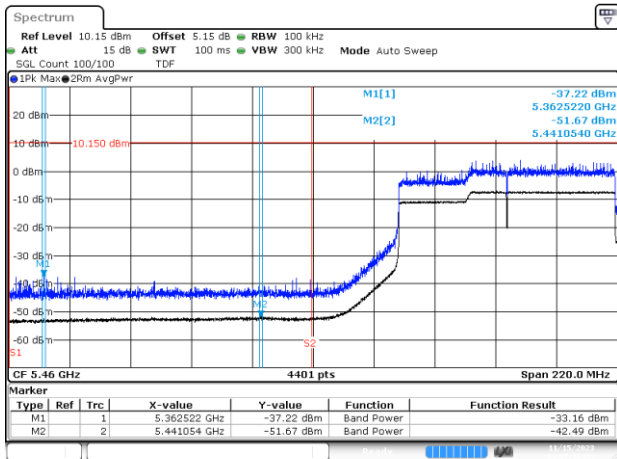

BE-R-LOW, SISO-A, 802.11ax/be160-MCS0, Ch114

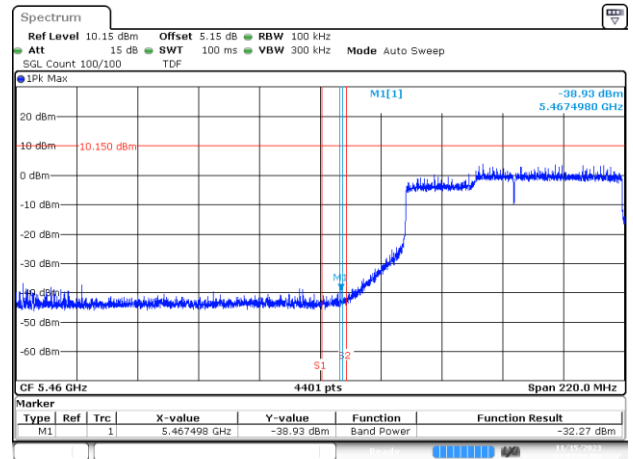

BE-NR-LOW, SISO-A, 802.11ax/be160-MCS0, Ch114

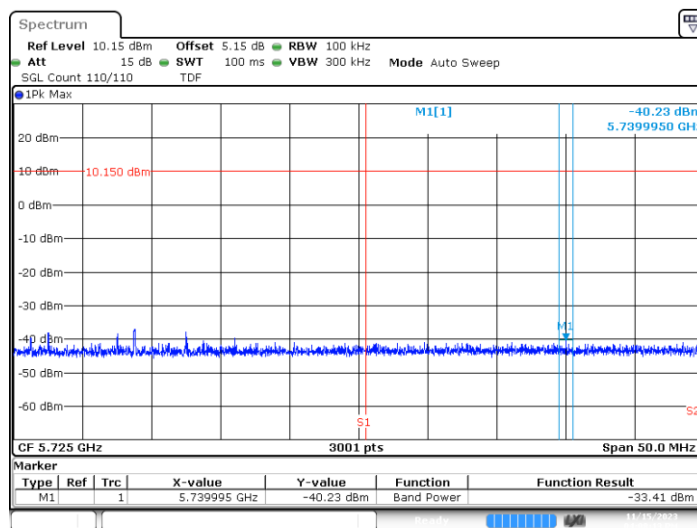

BE-NR-HIGH, SISO-A, 802.11ax/be160-MCS0, Ch114

SISO B

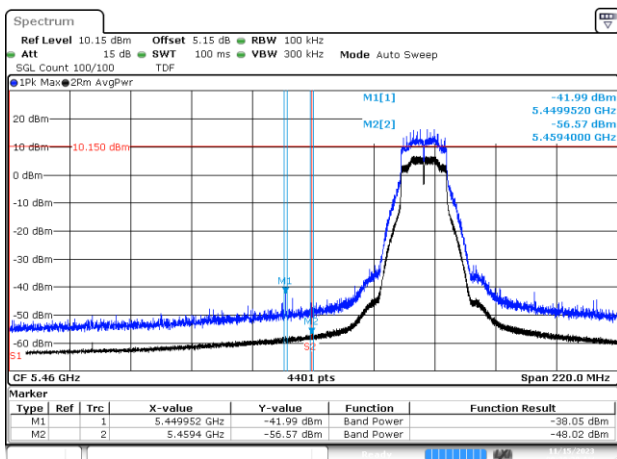

BE-R-LOW, SISO-A, 802.11a20-6Mbps, Ch100

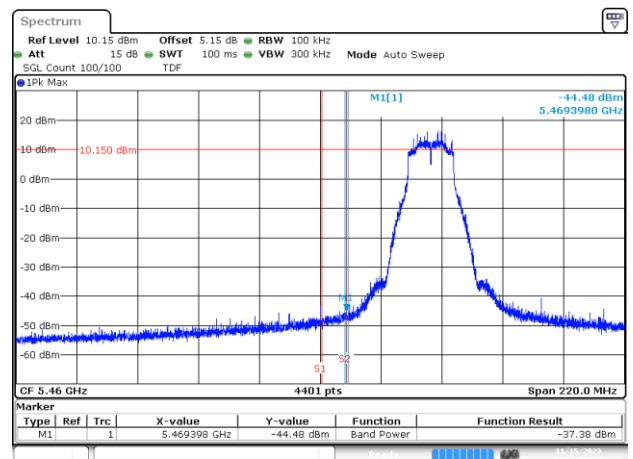

BE-NR-LOW, SISO-A, 802.11a20-6Mbps, Ch100

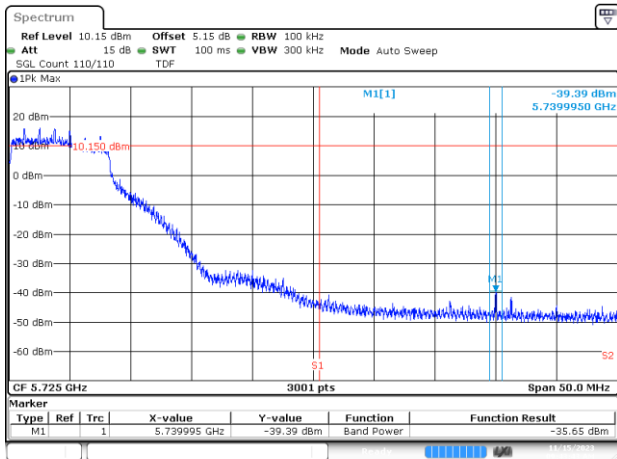

BE-NR-HIGH, SISO-A, 802.11a20-6Mbps, Ch140

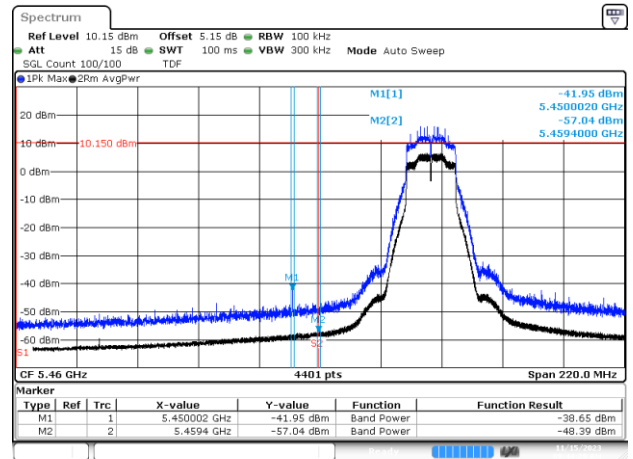

BE-R-LOW, SISO-A, 802.11n20-HT0, Ch100

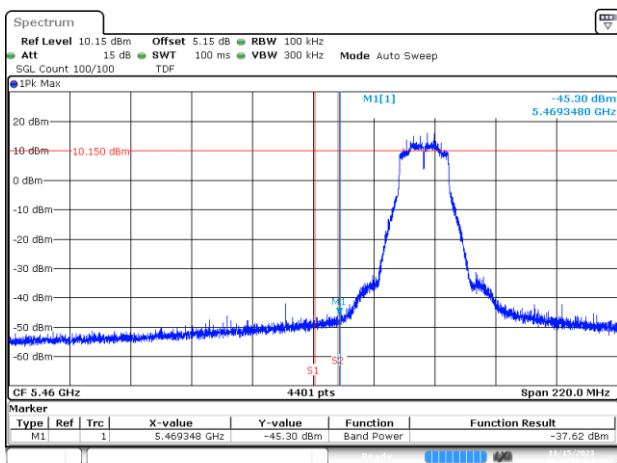

BE-NR-LOW, SISO-A, 802.11n20-HT0, Ch100

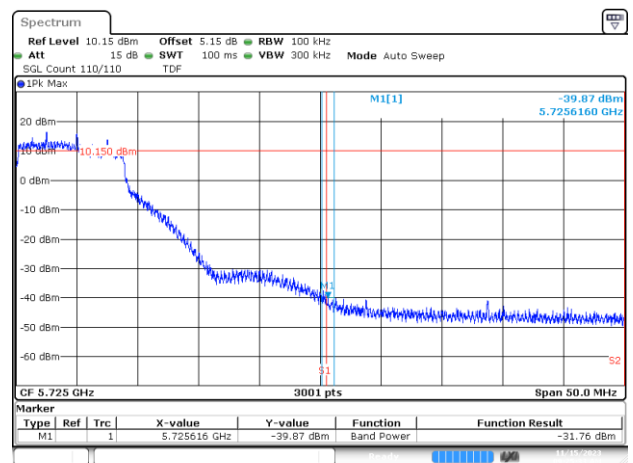

BE-NR-HIGH, SISO-A, 802.11n20-HT0, Ch140

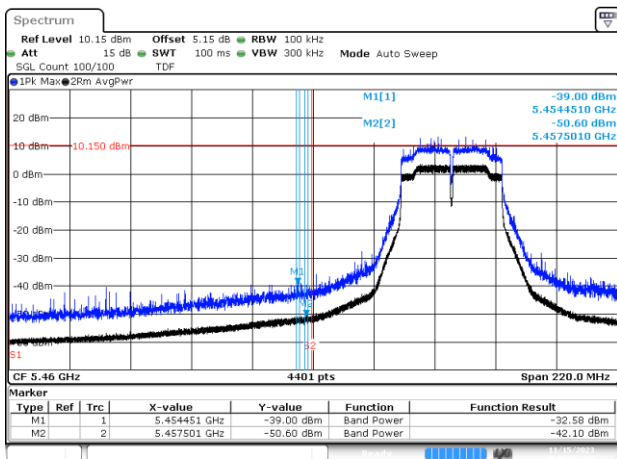

BE-R-LOW, SISO-A, 802.11n40-HT0, Ch102

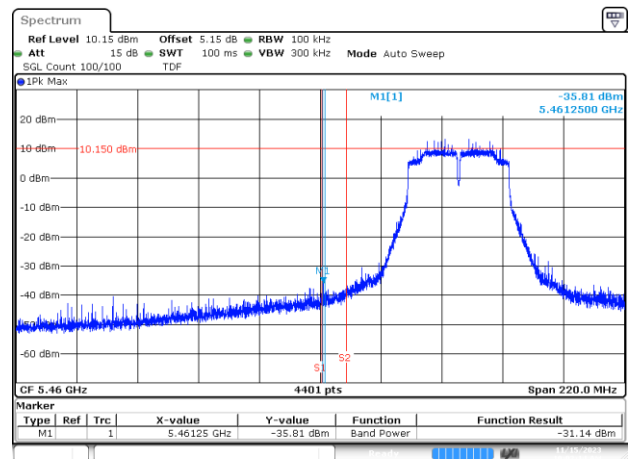

BE-NR-LOW, SISO-A, 802.11n40-HT0, Ch102

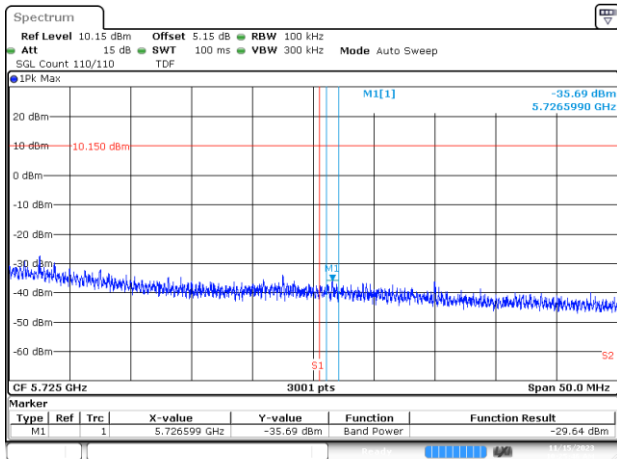

BE-NR-HIGH, SISO-A, 802.11n40-HT0, Ch134

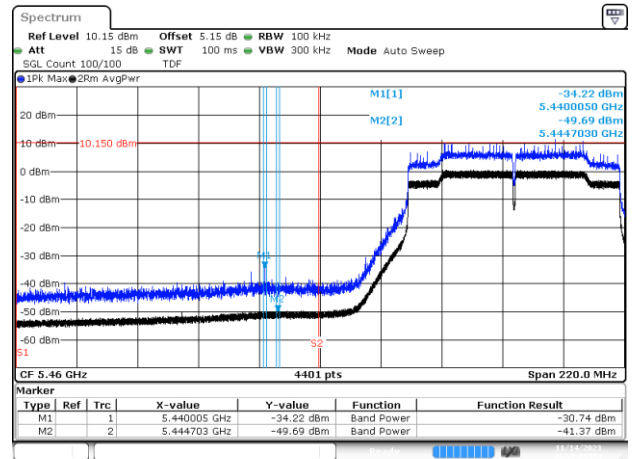

BE-R-LOW, SISO-A, 802.11ac80-VHT0, Ch106

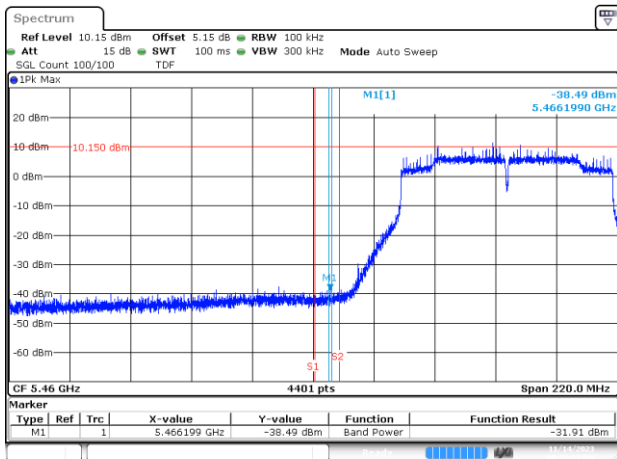

BE-NR-LOW, SISO-A, 802.11ac80-VHT0, Ch106

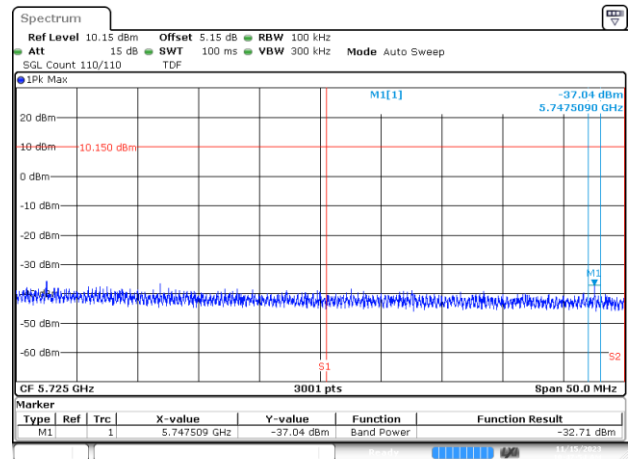

BE-NR-HIGH, SISO-A, 802.11ac80-VHT0, Ch122

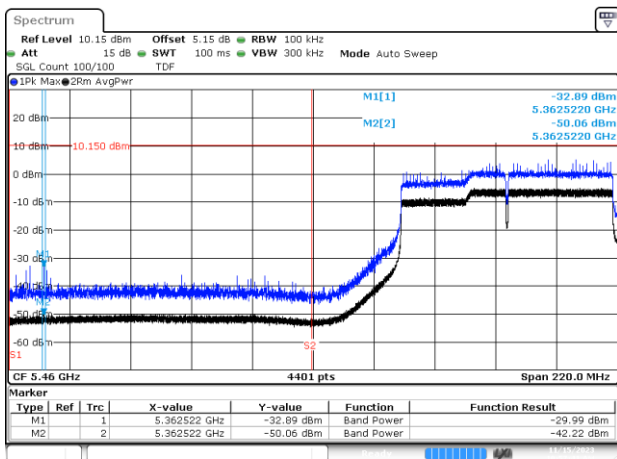

BE-R-LOW, SISO-A, 802.11ac160-VHT0, Ch114

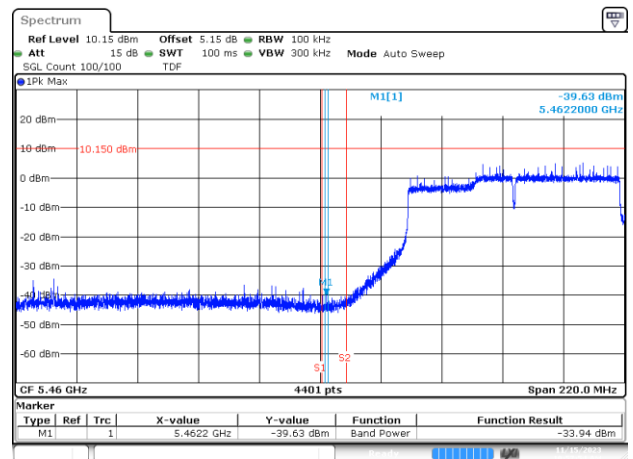

BE-NR-LOW, SISO-A, 802.11ac160-VHT0, Ch114

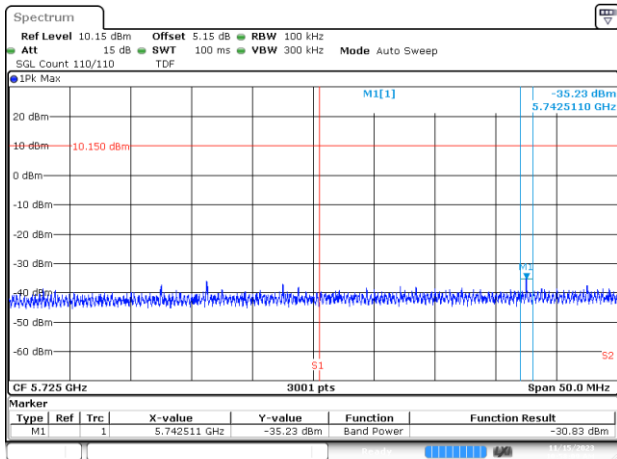

BE-NR-HIGH, SISO-A, 802.11ac160-VHT0, Ch114

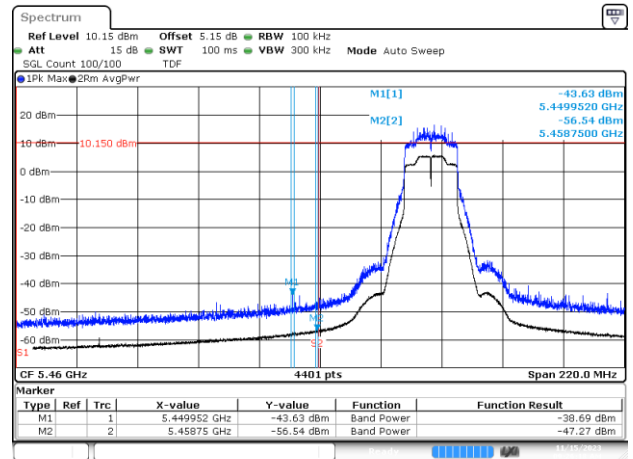

BE-R-LOW, SISO-A, 802.11ax/be20-MCS0, Ch100

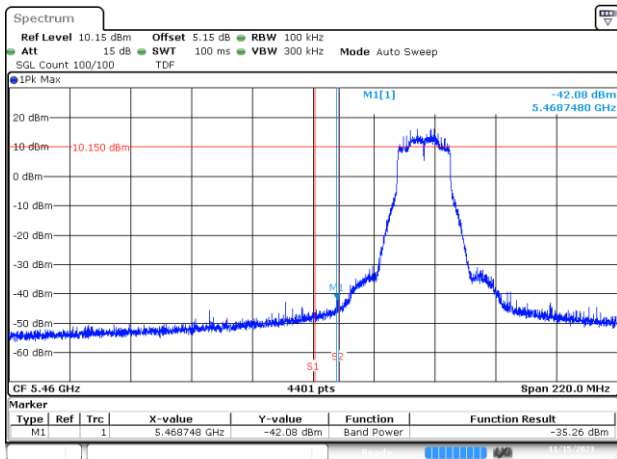

BE-NR-LOW, SISO-A, 802.11ax/be20-MCS0, Ch100

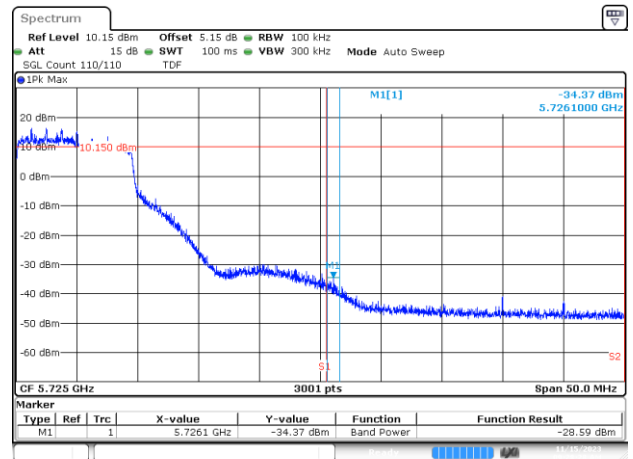

BE-NR-HIGH, SISO-A, 802.11ax/be20-MCS0, Ch140

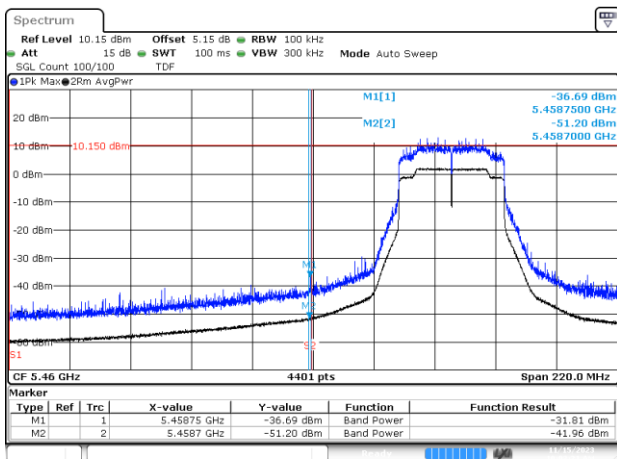

BE-R-LOW, SISO-A, 802.11ax/be40-MCS0, Ch102

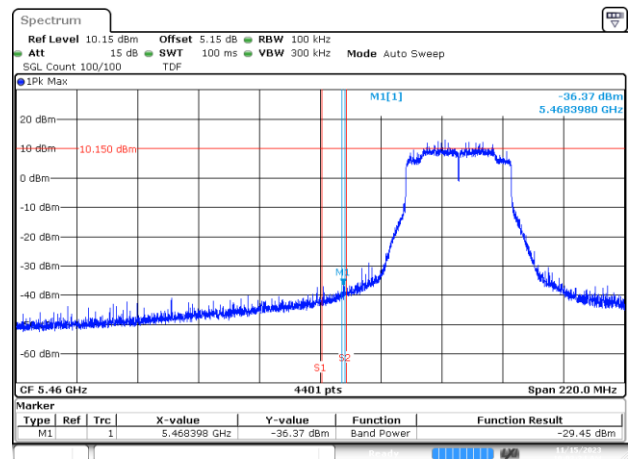

BE-NR-LOW, SISO-A, 802.11ax/be40-MCS0, Ch102

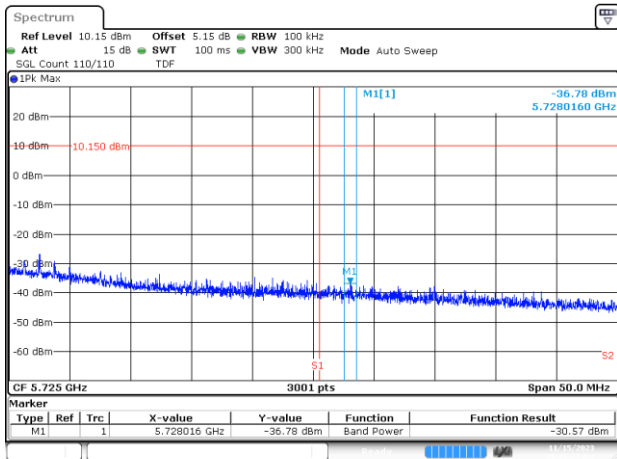

BE-NR-HIGH, SISO-A, 802.11ax/be40-MCS0, Ch134

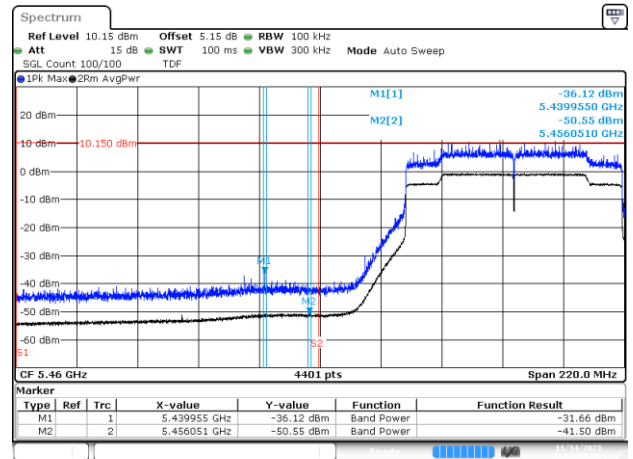

BE-R-LOW, SISO-A, 802.11ax/be80-MCS0, Ch106

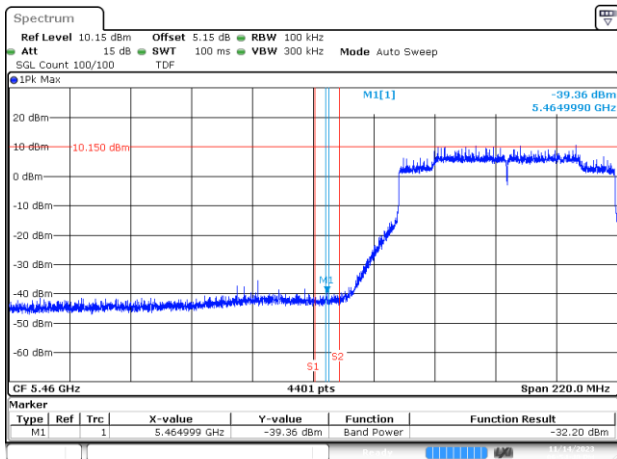

BE-NR-LOW, SISO-A, 802.11ax/be80-MCS0, Ch106

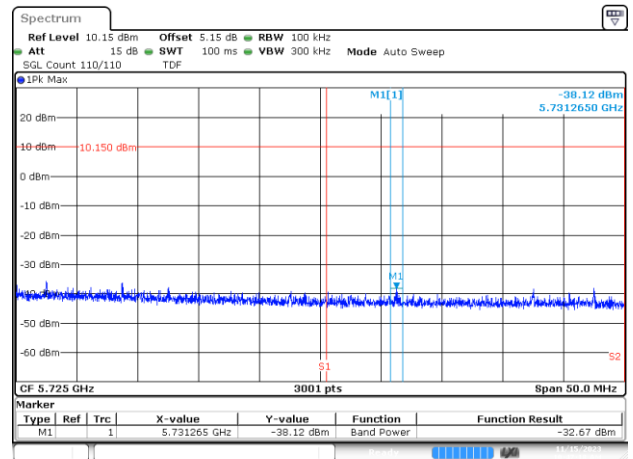

BE-NR-HIGH, SISO-A, 802.11ax/be80-MCS0, Ch122

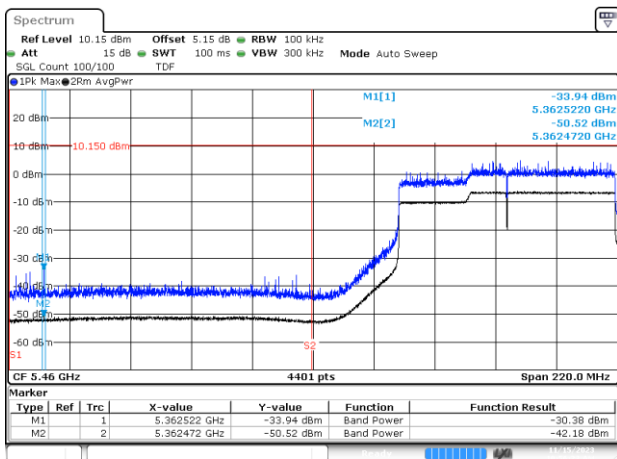

BE-R-LOW, SISO-A, 802.11ax/be160-MCS0, Ch114

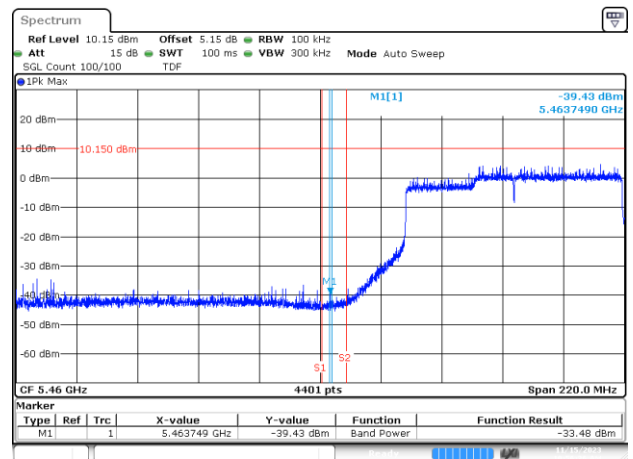

BE-NR-LOW, SISO-A, 802.11ax/be160-MCS0, Ch114