

# TEST REPORT

EUT Description	<b>WLAN and BT, 2x2 PCIe M.2 2230 adapter card</b>
Brand Name	<b>Intel®</b>
Model Name	<b>BE201NGW</b>
FCC/IC ID	<b>PD9BE201NG ; 1000M-BE201NG</b>
Date of Test Start/End	<b>2023-11-09 / 2023-11-23</b>
Features	<b>2x2 WiFi - Bluetooth®</b> (see section 5)

Applicant	<b>Intel Corporation SAS</b>
Address	<b>425 Rue de Goa – Le Cargo B6 – 06600 Antibes, FRANCE</b>
Contact Person	<b>Benjamin Lavenant</b>
Telephone/Fax/ Email	<b>Benjamin.lavenant@intel.com</b>

Reference Standards	<b>FCC Title 47 CFR part 15 - Subpart C</b> <b>RSS-247 issue 3 RSS-Gen A1 issue 5 - A1</b> (see section 1)
---------------------	--

Test Report identification	<b>231109-03.TR05</b>
Revision Control	<b>Rev. 00</b> <b>This test report revision replaces any previous test report revision</b> (see section 8)

The test results relate only to the samples tested.  
 Reference to accreditation shall be used only by full reproduction of test report.

\_\_\_\_\_ Issued by \_\_\_\_\_ Reviewed by \_\_\_\_\_

Cedric REQUIN  
 (Test Engineer Lead)

Zayd OUACHICHA  
 (Technical Manager)

# Table of Contents

---

<b>1. Standards, reference documents and applicable test methods .....</b>	<b>3</b>
<b>2. General conditions, competences and guarantees .....</b>	<b>3</b>
<b>3. Environmental Conditions .....</b>	<b>3</b>
<b>4. Test samples .....</b>	<b>4</b>
<b>5. EUT Features .....</b>	<b>5</b>
<b>6. Remarks and comments .....</b>	<b>5</b>
<b>7. Test Verdicts summary .....</b>	<b>6</b>
7.1. BLE .....	6
<b>8. Document Revision History .....</b>	<b>6</b>
<b>Annex A. Test &amp; System Description .....</b>	<b>7</b>
A.1 MEASUREMENT SYSTEM.....	7
A.2 TEST EQUIPMENT LIST .....	9
A.3 MEASUREMENT UNCERTAINTY EVALUATION .....	10
<b>Annex B. Test Results .....</b>	<b>11</b>
B.1 TEST RESULTS BLE .....	11
B.1.1 6dB & 99% Bandwidth.....	11
B.1.2 Maximum Output Power and antenna gain.....	15
B.1.3 Power Spectral Density .....	20
B.1.4 Out-of-band emission (Conducted).....	23
B.1.5 Radiated spurious emission.....	26
<b>Annex C. Photographs .....</b>	<b>28</b>
C.1 TEST SETUP .....	28
C.2 TEST SAMPLE .....	30

## 1. Standards, reference documents and applicable test methods

FCC	<ol style="list-style-type: none"> <li>1. FCC Title 47 CFR part 15 - Subpart C – §15.247 Operation within the bands 902-928 MHz, 2400-2483.5 MHz, and 5725-5850 MHz. 2021-10-01 Edition</li> <li>2. FCC Title 47 CFR part 15 - Subpart C – §15.209 Radiated emission limits; general requirements. 2021-10-01 Edition</li> <li>3. FCC OET KDB 558074 D01 v05r02 - Guidance for compliance measurements on digital transmission system, frequency hopping spread spectrum system, and hybrid system devices operating under section 15.247 of the FCC rules.</li> <li>4. FCC OET KDB 662911 D01 v02r01 - Emissions Testing of Transmitters with Multiple Outputs in the Same Band.</li> <li>5. ANSI C63.10-2013 - American National Standard of Procedures for Compliance Testing of Unlicensed Wireless Devices</li> </ol>
ISED	<ol style="list-style-type: none"> <li>1. RSS-247 Issue 3 - Digital Transmission Systems (DTSs), Frequency Hopping Systems (FHSs) and License-Exempt Local Area Network (LE-LAN) Devices.</li> <li>2. RSS-Gen Issue 5 A1- General Requirements for Compliance of Radio Apparatus.</li> <li>3. FCC OET KDB 558074 D01 v05r02 - Guidance for compliance measurements on digital transmission system, frequency hopping spread spectrum system, and hybrid system devices operating under section 15.247 of the FCC rules.</li> <li>4. FCC OET KDB 662911 D01 v02r01 - Emissions Testing of Transmitters with Multiple Outputs in the Same Band.</li> <li>5. ANSI C63.10-2013 - American National Standard of Procedures for Compliance Testing of Unlicensed Wireless Devices</li> </ol>

## 2. General conditions, competences and guarantees

- ✓ Tests performed under FCC standards identified in section 1 are covered by A2LA accreditation.
- ✓ Tests performed under ISED standards identified in section 1 are covered by Cofrac accreditation.
- ✓ Intel Corporation SAS Wireless RF Lab (Intel WRF Lab) is an ISO/IEC 17025:2017 laboratory accredited by the American Association for Laboratory Accreditation (A2LA) with the certificate number 3478.01.
- ✓ Intel Corporation SAS Wireless RF Lab (Intel WRF Lab) is an Accredited Test Firm recognized by the FCC, with Designation Number FR0011.
- ✓ Intel Corporation SAS Wireless RF Lab (Intel WRF Lab) is an ISO/IEC 17025:2017 testing laboratory accredited by the French Committee for Accreditation (Cofrac) with the certificate number 1-6736.
- ✓ Intel Corporation SAS Wireless RF Lab (Intel WRF Lab) is a Registered Test Site listed by ISED, with ISED company number 1000Y and CAB identifier FR0005.
- ✓ Intel WRF Lab only provides testing services and is committed to providing reliable, unbiased test results and interpretations.
- ✓ Intel WRF Lab is liable to the client for the maintenance of the confidentiality of all information related to the item under test and the results of the test.
- ✓ Intel WRF Lab has developed calibration and proficiency programs for its measurement equipment to ensure correlated and reliable results to its customers.
- ✓ This report is only referred to the item that has undergone the test.
- ✓ This report does not imply an approval of the product by the Certification Bodies or competent Authorities.

## 3. Environmental Conditions

- ✓ At the site where the measurements were performed the following limits were not exceeded during the tests:

Temperature	23.3+/-2.5°C
Humidity	35.4+/-10.6%

#### 4. Test samples

Sample	Control #	Description	Model	Serial #	Date of receipt	Note
#1	231109-03.S04	WiFi 7 Module	BE201NGW	A002A5B1A56C	2023-11-10	Used for RF conducted tests
	200203-01.S10	Laptop	HP (HSN-I38C)	000951007L	2023-04-24	
	231109-03.S31	CRF DB 2230 BNJ Extender Board	PCB00862-00_A	ASS00862-01-0A	2023-11-10	
#2	231109-03.S09	WiFi 7 Module	BE201NGW	A002A5B1A61B	2023-11-13	Used for Radiated Spurious Emissions tests
	220225-03.S07	Microwave Absorber	Eccosorb BSR-1	-	2022-03-14	
	231109-03.S48	Adaptor	PCB00866-00_A	124627	2023-11-24	
	200611-03.S31	Extender	ADEXELEC	-	2020-08-19	
	200504-04.S07	Laptop	Latitude 5401	BVHLK13	2020-06-02	
	230223-02.S47	Triband Antenna	-	005	2023-04-20	
	230223-02.S48	Triband Antenna	-	006	2023-04-20	
#3	231109-03.S01	WiFi 7 Module	BE201NGW	A002A5B1A620	2023-11-24	Used for Radiated Spurious Emissions tests
	220225-03.S07	Microwave Absorber	Eccosorb BSR-1	-	2022-03-14	
	231109-03.S47	Adaptor	PCB00866-00_A	124727	2023-11-24	
	220915-09.S01	Extender	ADEXELEC	-	2022-04-06	
	200611-03.S30	Laptop	Latitude 5401	6DJLK13	2020-08-19	
	230223-02.S49	Triband Antenna	-	007	2023-04-20	
	230223-02.S50	Triband Antenna	-	008	2023-04-20	

## 5. EUT Features

The herein information is provided by the customer

Intel WRF Lab declines any responsibility for the accuracy of the stated customer provided information, especially if it has any impact on the correctness of test results presented in this report

Brand Name	Intel®		
Model Name	BE201NGW		
Software Version	DRTU.05312.99.0.84		
Driver Version	23.10.23361.24681		
Prototype / Production	Production		
Supported Radios	802.11b/g/n/ac/ax/be	2.4GHz	
	802.11a/n/ac/ax/be	5.2GHz	
		5.6GHz	
		5.8GHz	
	802.11ax/be	6.0GHz	
	Bluetooth	2.4GHz	
Antenna Information	Transmitter	Chain A(1)	Chain B(2)
	Manufacturer	Intel WRF Lab	Intel WRF Lab
	Antenna type	PIFA	PIFA
	Part number	WRF-Tri Band-Antenna	WRF-Tri Band-Antenna
	Antenna peak gain (dBi)	+3	+3

## 6. Remarks and comments

1. No deviations were made from the test methods listed in section 1 of this report

## 7. Test Verdicts summary

The statement of conformity to applicable standards in the table below are based on the measured values, without taking into account the measurement uncertainties.

### 7.1. BLE

FCC part	RSS part	Test name	Verdict
15.247 (a) (2)	RSS-247 Clause 5.2 (a)	6dB Bandwidth	P
15.247 (b) (3)	RSS-247 Clause 5.4 (d)	Maximum output power and E.I.R.P.	P
15.247 (e)	RSS-247 Clause 5.2 (b)	Power spectral density	P
15.247 (d) 15.209	RSS-247 Clause 5.5 RSS-Gen A1 Clause 8.9	Out-of-band Emissions (conducted)	P
15.247 (d) 15.209	RSS-247 Clause 5.5 RSS-Gen A1 Clause 8.9	Spurious Emissions (radiated)	P

P: Pass  
 F: Fail  
 NM: Not Measured  
 NA: Not Applicable

## 8. Document Revision History

Revision #	Modified by	Revision Details
Rev. 00	T.MATHIEU R.SIMONINI	First Issue

# Annex A. Test & System Description

## A.1 Measurement System

Measurements were performed using the following setups, made in accordance to the general provisions of FCC OET KDB 558074 D01 DTS Meas Guidance.

The DUT was installed in a test fixture and this test fixture is connected to a laptop computer and AC/DC power adapter. The laptop computer was used to configure the EUT to continuously transmit at a specified output power using all different modes and modulation schemes, using the Intel proprietary tool DRTU.

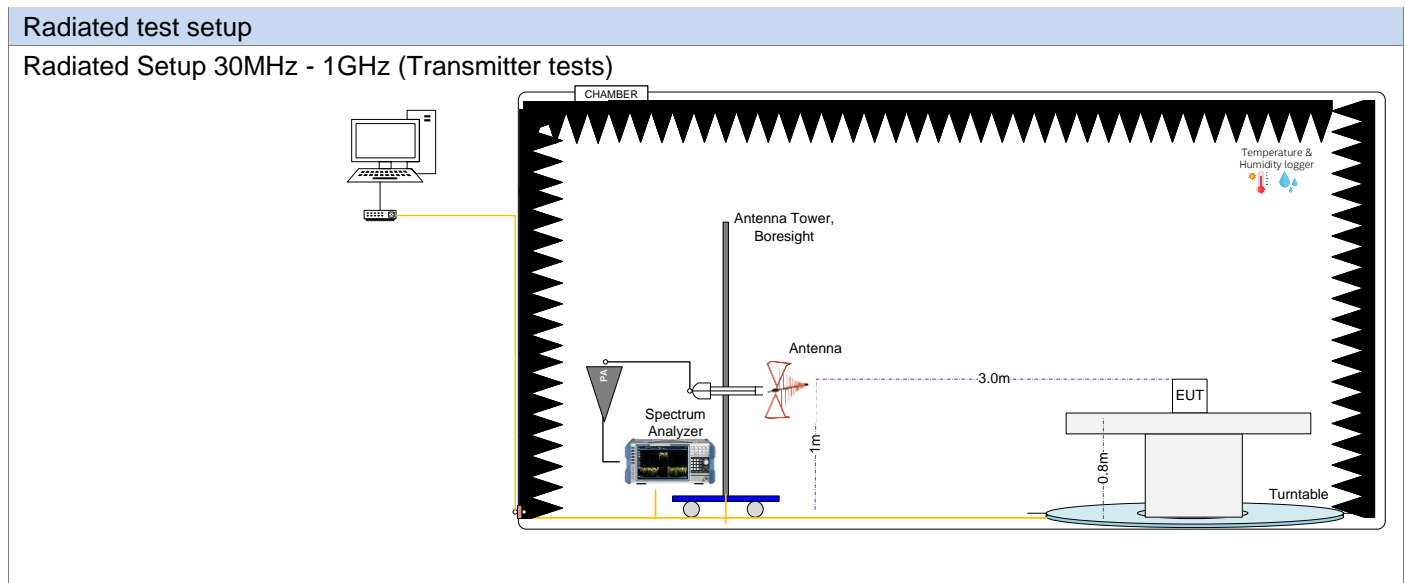
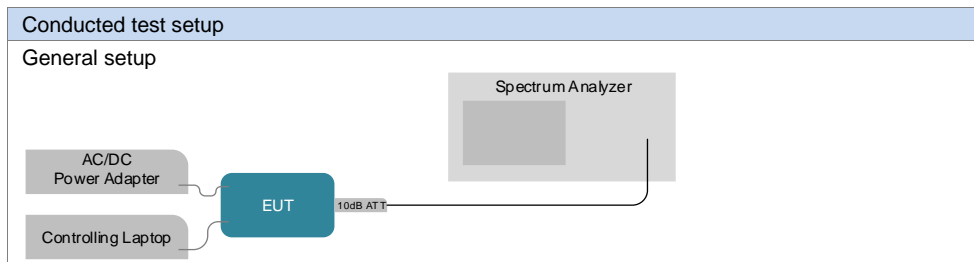

Radiated Setup 1GHz – 10GHz (Transmitter tests)

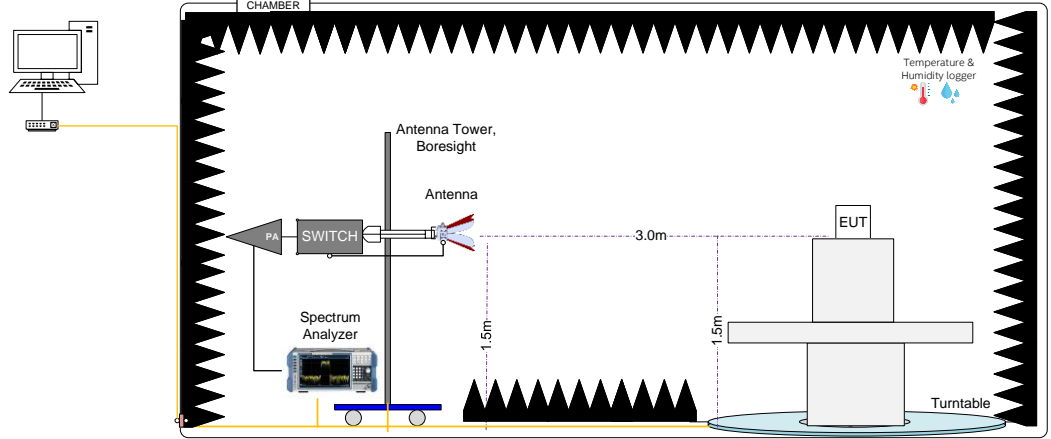

Radiated Setup 10GHz – 26GHz (Transmitter tests)

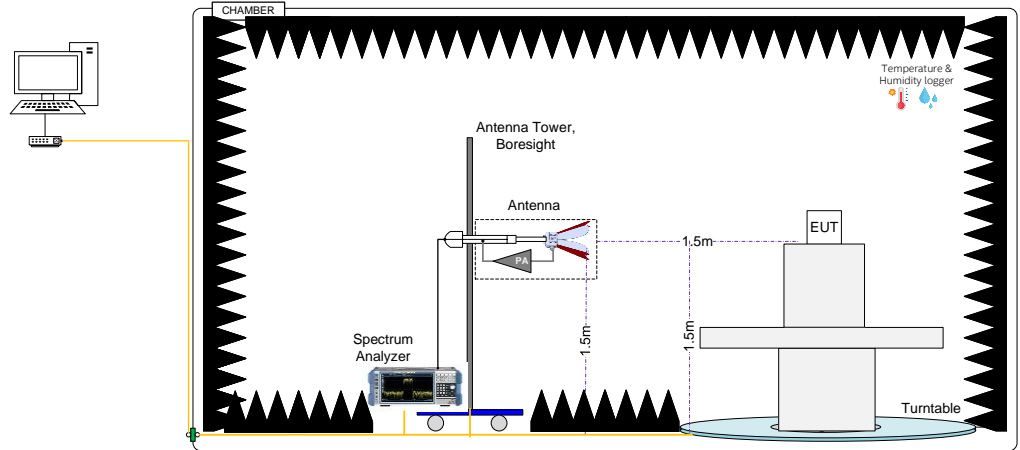

Sample Calculation

The spurious received voltage  $V$  (dB $\mu$ V) in the spectrum Analyzer is converted to Electric field strength using the transducer factor  $F$  corresponding to the Rx path Loss:

$$F \text{ (dB/m)} = \text{Rx Antenna Factor (dB/m)} + \text{Cable losses (dB)} - \text{Amplifiers Gain (dBi)}$$

$$E \text{ (dB}\mu\text{V)} = V \text{ (dB}\mu\text{V)} + F \text{ (dB/m)}$$

For field strength measurements made at other than the distance at which the applicable limit is specified, the field strength of the emission at the distance specified by the limit is deduced as follows:

$$E_{\text{SpecLimit}} = E_{\text{Meas}} + 20 \cdot \log(D_{\text{Meas}}/D_{\text{SpecLimit}})$$

where

$E_{\text{SpecLimit}}$  is the field strength of the emission at the distance specified by the limit, in dB $\mu$ V/m

$E_{\text{Meas}}$  is the field strength of the emission at the measurement distance, in dB $\mu$ V/m

$D_{\text{Meas}}$  is the measurement distance, in m

$D_{\text{SpecLimit}}$  is the distance specified by the limit, in m



## A.2 Test Equipment List

### Conducted setup

ID#	Device	Type/Model	Serial #	Manufacturer	Cal. Date	Cal. Due Date
273-000	Spectrum Analyzer	FSV30	103309	Rohde & Schwarz	2023-01-02	2025-01-02
018-003	RF cable 50cm	PE360-50CM	N/A	PASTERNAK	2023-03-03	2024-03-03
018-001	10dB Attenuator + MH4	N/A	N/A	N/A	2023-03-03	2024-03-03
407-000	Temp & Humidity Logger	RA12E-TH1-RAS	RA12-E16EDA	AVITECH	2023-07-12	2025-07-12
413-000	Measurement SW v1.5.4.2	Octopi	N/A	Step AT	N/A	N/A

### Radiated Setup #1

ID#	Device	Type/Model	Serial #	Manufacturer	Cal. Date	Cal. Due Date
006-000	Anechoic Chamber	FACT3	5720	ETS-Lindgren	2022-01-21	2024-01-21
006-008	Measurement SW, v11.30	EMC32	100623	Rohde & Schwarz	N/A	N/A
259-000	Temp & Humidity Logger	RA12E-TH-RAS	RA12-B9BD70	Avtech	2022-06-27	2024-06-27
006-001	Turn Table	ETS	-	ETS-Lindgren	N/A	N/A
006-011	Boresight antenna mast	BAM 4.0-P	P/278/2890.01	Maturo	N/A	N/A
007-008	Double Horn Ridged antenna +PA	3116C-PA	00169308bis + 00196308	ETS-Lindgren	2023-0-30	2025-05-30
057-000	Double Horn Ridged antenna	3117	167062	ETS-Lindgren	2022-07-08	2024-07-08
006-061	Bi-Log Periodic antenna	CBL6143A	61382	Teseq	2022-10-24	2024-10-24
147-000	Spectrum analyzer	FSW43	101847	Rohde & Schwarz	2022-11-30	2024-11-30
301-000	Amplifier 9kHz-1300MHz	8447F	3113A07440	HP	2023-03-03	2024-03-03
261-000	Amplifier 1GHz-18GHz	3117-PA	00157993	ETS-Lindgren	2023-02-20	2024-02-20
006-068	RF Switch	RC-2SP6T-40	02112090061	Micro-Circuits	2023-08-22	2024-08-22
006-059	Cable 7m – 25MHz to 40GHz	R286304174	20.46.369	Radiall	2023-02-20	2024-02-20
006-063	Cable 30cm – 1GHz to 40GHz	PE371-12	-	Pasternack	2023-02-27	2024-02-27
006-064	Cable 30cm – 1GHz to 40GHz	PE371-12	-	Pasternack	2023-02-27	2024-02-27
006-065	Cable 60cm – 25MHz to 1GHz	PE300-24	-	Pasternack	2023-06-02	2024-06-02

N/A: Not Applicable

### Radiated Setup #2

ID#	Device	Type/Model	Serial #	Manufacturer	Cal. Date	Cal. Due Date
127-000	Spectrum Analyzer	FSV40	101358	Rohde & Schwarz	2023-01-27	2025-01-27
007-007	Double Ridge Horn (1- 18GHz)	3117	00152266	ETS Lindgren	2022-03-29	2024-03-29
007-006	Switch & Positioner	EMCenter	00151232	ETS Lindgren	N/A	N/A
007-011	RF Cable 1-18GHz - 6.5m	140-8500-11-51	001	Atem	2023-02-15	2024-02-15
007-005	Measurement SW, v11.20.00	EMC32	100401	Rohde & Schwarz	N/A	N/A
007-000	Anechoic chamber	RFD-FA-100	5996	ETS Lindgren	2021-09-14	2024-03-14
007-003	Antenna Tower	2171B-3.0M	00150123	ETS Lindgren	N/A	N/A
007-002	Turntable	-	-	ETS Lindgren	N/A	N/A
007-014	RF Cable 18-40 GHz 6m	R286304009	1747364	Radiall	2023-02-16	2024-02-16
007-022	RF Cable 1-18GHz, 1.5m	0501050991200GX	19.23.493	Radiall	2023-02-13	2024-02-13
007-015	RF Cable 1GHz-18GHz 1.5m	-	-	Spirent	2023-02-13	2024-02-13
007-018	RF Cable 1-9.5GHz 1.2m	0500990991200KE	-	Radiall	2023-02-13	2024-02-13
007-020	RF Cable 1-18GHz, 1.2 m	2301761761200PJ	12.22.1104	Radiall	2023-02-15	2024-02-15
325-000	Temp & Humidity Logger	RA12E-TH1-RAS	RA12-B9B7C6	Avtech	2022-01-17	2024-01-17

N/A: Not Applicable

Shared Radiated Equipment

ID#	Device	Type/Model	Serial #	Manufacturer	Cal. Date	Cal. Due Date
412-000	DRTU Power finder V2.1	-	-	Intel	NA	NA
139-000	Power Sensor	NRP-Z81	104383	Rohde & Schwarz	2023-04-21	2025-04-21
061-000	Power Sensor	NRP-Z81	104386	Rohde & Schwarz	2022-03-25	2024-03-25
140-000	Power Sensor	NRP-Z81	104382	Rohde & Schwarz	2022-03-25	2024-03-25
423-000	Power Sensor	NRP-Z81	101152	Rohde & Schwarz	2022-05-18	2024-05-18

N/A: Not Applicable

### A.3 Measurement Uncertainty Evaluation

The system uncertainty evaluation is shown in the table below with a coverage factor of  $k = 2$  to indicate a 95% level of confidence:

Measurement type	Uncertainty	Unit
Timing	$\pm 0.12$	%
Power Spectral density	$\pm 1.47$	dB
Occupied bandwidth	$\pm 2.07$	%
Conducted Power	$\pm 1.03$	dB
Conducted Spurious Emission <26.5 GHz	$\pm 2.93$	dB
Radiated tests <1GHz	$\pm 6.40$	dB
Radiated tests 1GHz – 26.5 GHz	$\pm 5.92$	dB

# Annex B. Test Results

The herein test results were performed by:

Test case measurement	Test Peronnel
6dB Bandwidth	T.MATHIEU
Maximum output power and E.I.R.P	T.MATHIEU
Power spectral density	T.MATHIEU
Out-of-band Emissions (conducted)	T.MATHIEU
Spurious Emissions (radiated)	K.KHATIB, R.SIMONINI

## B.1 Test Results BLE

### B.1.1 6dB & 99% Bandwidth

#### Test limits

FCC part	RSS part	Limits
15.247 (a) (2)	RSS-247 Clause 5.2 (a)	Systems using digital modulation techniques may operate in the 902-928 MHz, 2400-2483.5 MHz, and 5725-5850 MHz bands. The minimum 6 dB bandwidth shall be at least 500 kHz.

#### Test procedure

The conducted setup shown in section *Test & System Description* was used to measure the 6dB & 99% Bandwidth. The antenna terminal of the EUT is connected to the spectrum through an attenuator, and the spectrum analyzer reading is compensated to include the RF path loss.

#### Results tables

Mode	Frequency [MHz]	6dB BW [MHz]	99% BW [MHz]
BLE	2402	1.17	2.05
	2440	1.17	2.05
	2480	1.17	2.05

**Results screenshot**

**BLE**

**6dB BW – 2402 MHz**

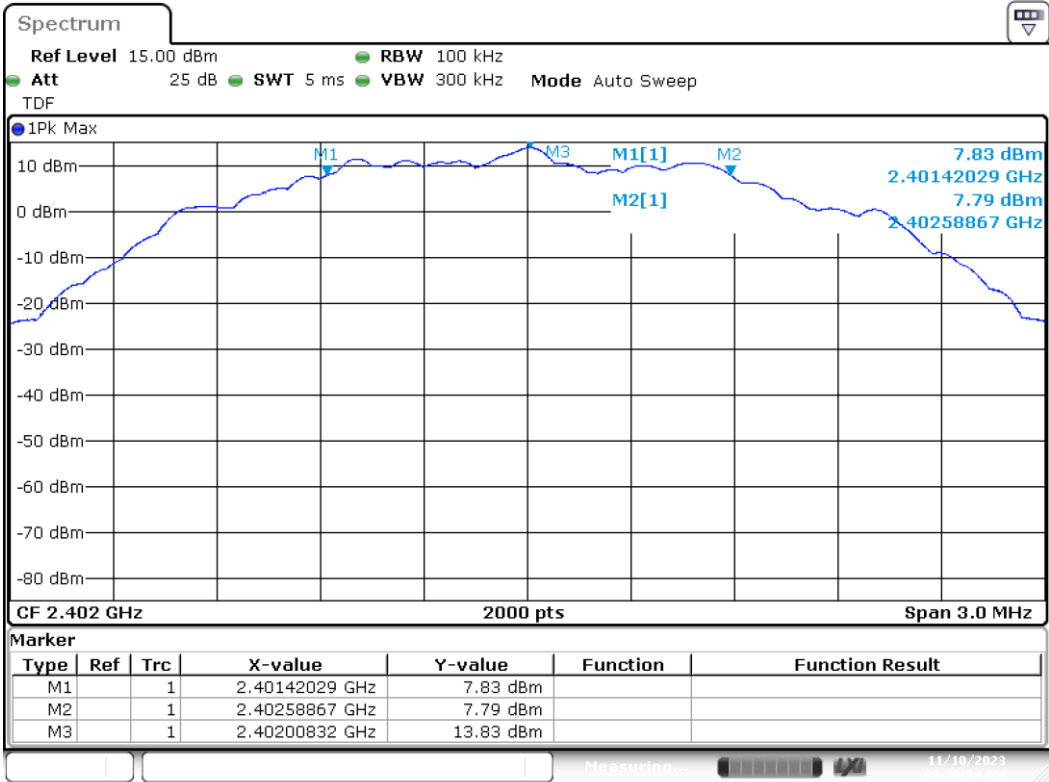

Date: 10.NOV.2023 09:40:55

**99% BW – 2402 MHz**

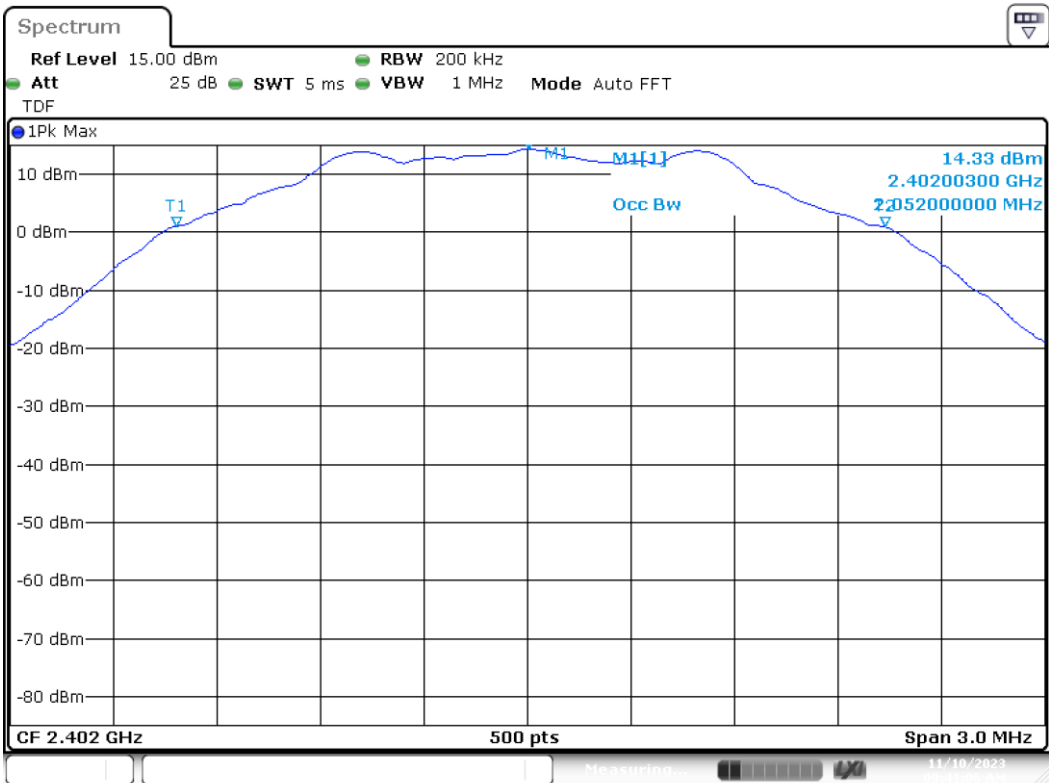

Date: 10.NOV.2023 09:41:06

**6dB BW – 2440 MHz**

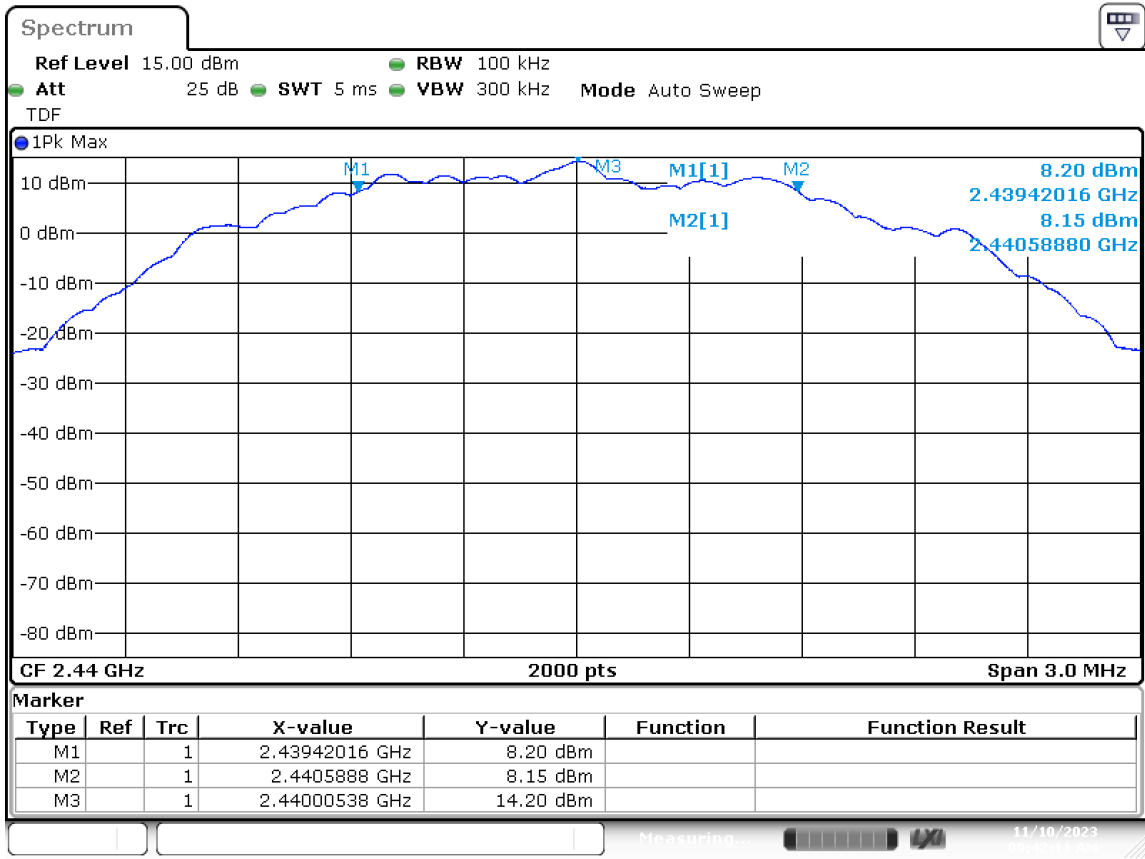

Date: 10.NOV.2023 09:42:11

**99% BW – 2440 MHz**

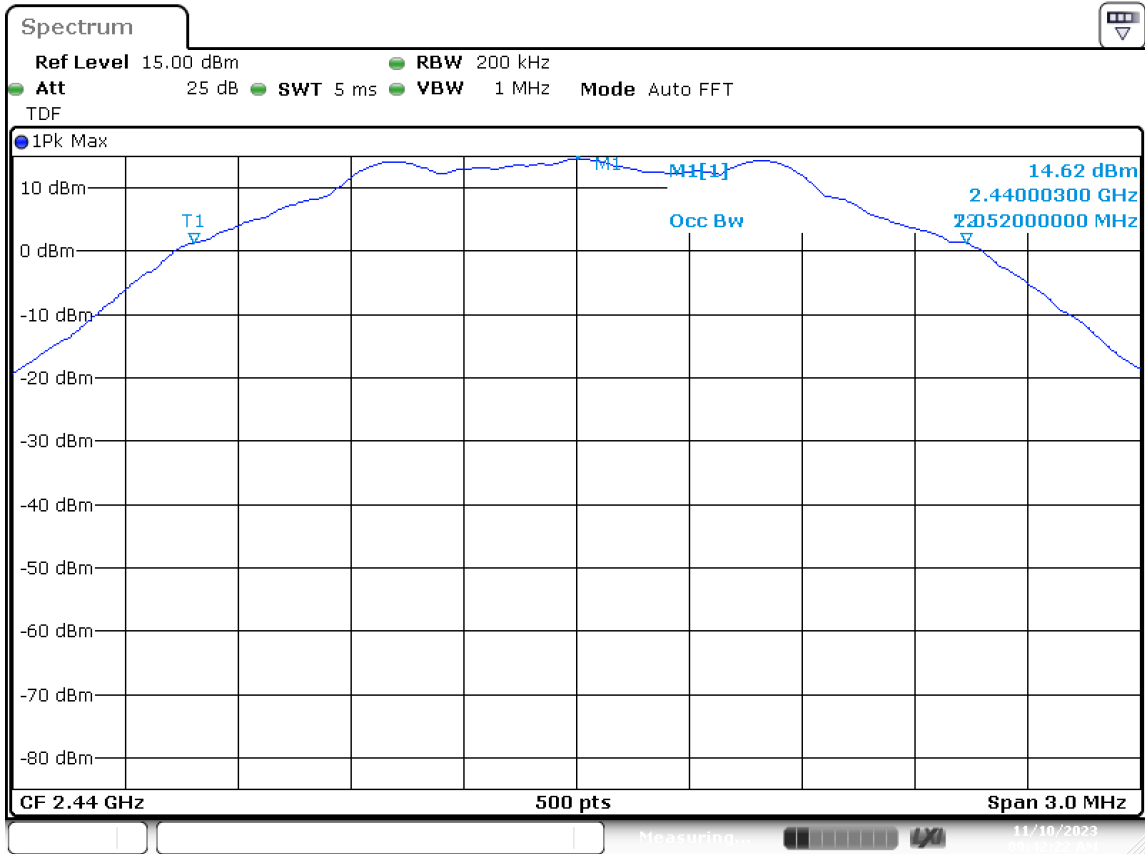

Date: 10.NOV.2023 09:42:23

**6dB BW – 2480 MHz**

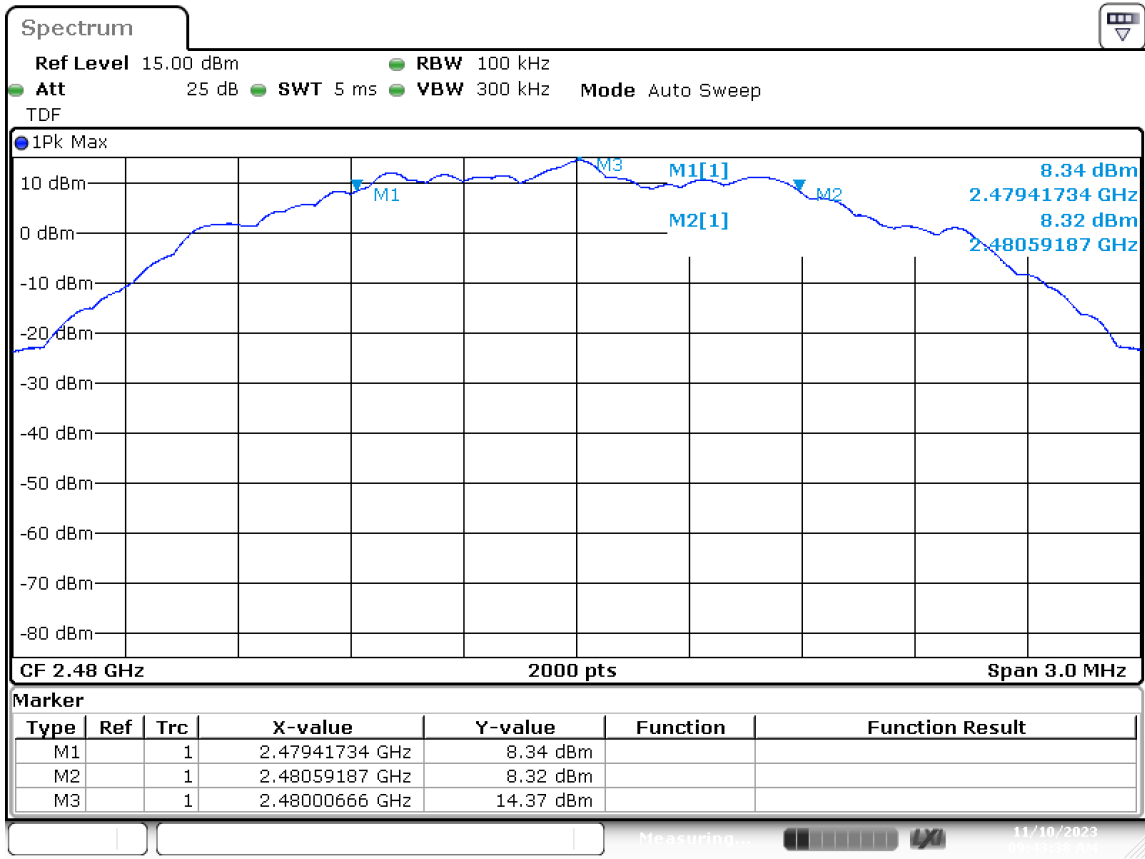

Date: 10.NOV.2023 09:43:39

**99% BW – 2480 MHz**

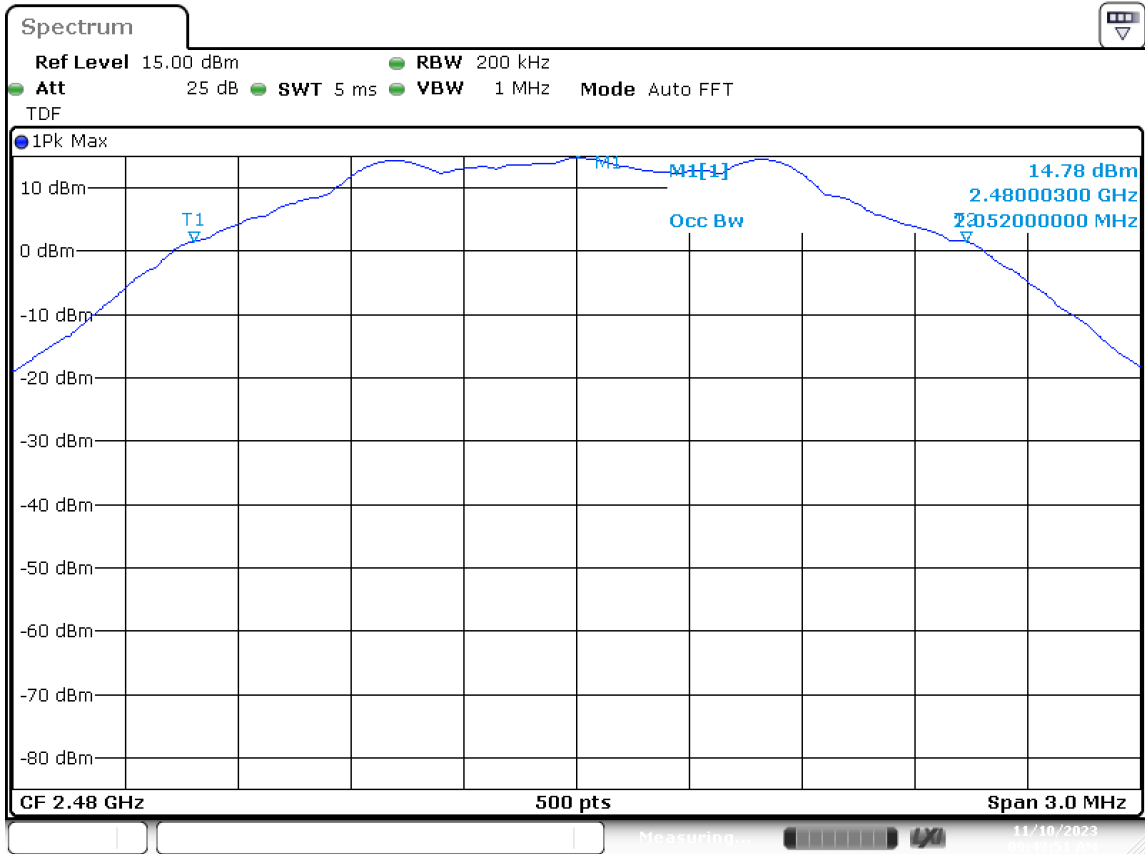

Date: 10.NOV.2023 09:43:51

## B.1.2 Maximum Output Power and antenna gain

### Test limits

	Limits
<p>FCC Part 15.247 (b) (3)</p>	<p>(b) The maximum peak conducted output power of the intentional radiator shall not exceed the following:</p> <p>(3) For systems using digital modulation in the 902-928 MHz, 2400-2483.5 MHz, and 5725-5850 MHz bands: 1 Watt. As an alternative to a peak power measurement, compliance with the one Watt limit can be based on a measurement of the maximum conducted output power. Maximum Conducted Output Power is defined as the total transmit power delivered to all antennas and antenna elements averaged across all symbols in the signaling alphabet when the transmitter is operating at its maximum power control level. Power must be summed across all antennas and antenna elements. The average must not include any time intervals during which the transmitter is off or is transmitting at a reduced power level.</p> <p>(4) The conducted output power limit specified in paragraph (b) of this section is based on the use of antennas with directional gains that do not exceed 6 dBi.</p>
<p>RSS-247 Clause 5.4 (d)</p>	<p>For DTSs employing digital modulation techniques operating in the bands 902-928 MHz and 2400-2483.5 MHz, the maximum peak conducted output power shall not exceed 1W. The e.i.r.p. shall not exceed 4 W, except as provided in section 5.4(e).</p> <p>As an alternative to a peak power measurement, compliance can be based on a measurement of the maximum conducted output power. The maximum conducted output power is the total transmit power delivered to all antennas and antenna elements, averaged across all symbols in the signalling alphabet when the transmitter is operating at its maximum power control level. Power must be summed across all antennas and antenna elements. The average must not include any time intervals during which the transmitter is off or transmitting at a reduced power level. If multiple modes of operation are implemented, the maximum conducted output power is the highest total transmit power occurring in any mode</p>

### Test procedure:

The Maximum peak conducted output power was measured using the  $RBW \geq DTS \text{ bandwidth}$  method defined in paragraph 11.9.1.1 of ANSI C63.10-2013.

The Maximum conducted average output power was measured using the channel integration method according to Method AVGSA-2, defined in paragraph 11.9.2.2.4 of ANSI C63.10-2013.

The EIRP power (dBm) is calculated by adding the declared maximum antenna gain to the measured conducted power.

The conducted setup shown in section *Test & System Description* was used to measure the maximum conducted output power. The antenna terminal of the EUT is connected to the spectrum through an attenuator, and the spectrum analyzer reading is compensated to include the RF path loss.

Results tables

			Peak Power [dBm]		
Mode	Measured. Duty Cycle [%]	Frequency [MHz]	Measured Conducted Output Power	EIRP	Peak Output Power [mW]
BLE	31.23	2402	14.87	17.87	30.69
		2440	15.15	18.15	32.73
		2480	15.28	18.28	33.73

Max Value

Min Value

			Average Output Power*[dBm]			
Mode	Measured. Duty Cycle [%]	Frequency [MHz]	Measured Maximum Conducted Power	Compensated Conducted Power	EIRP	Average Output Power [mW]
BLE	31.23	2402	9.62	14.67	17.91	29.34
		2440	9.99	15.04	18.28	31.95
		2480	10.16	15.21	18.45	33.23

\* Output Power RMS values are shown for indicative purpose only



Results screenshot

### BLE

#### Max Power Peak – 2402 MHz

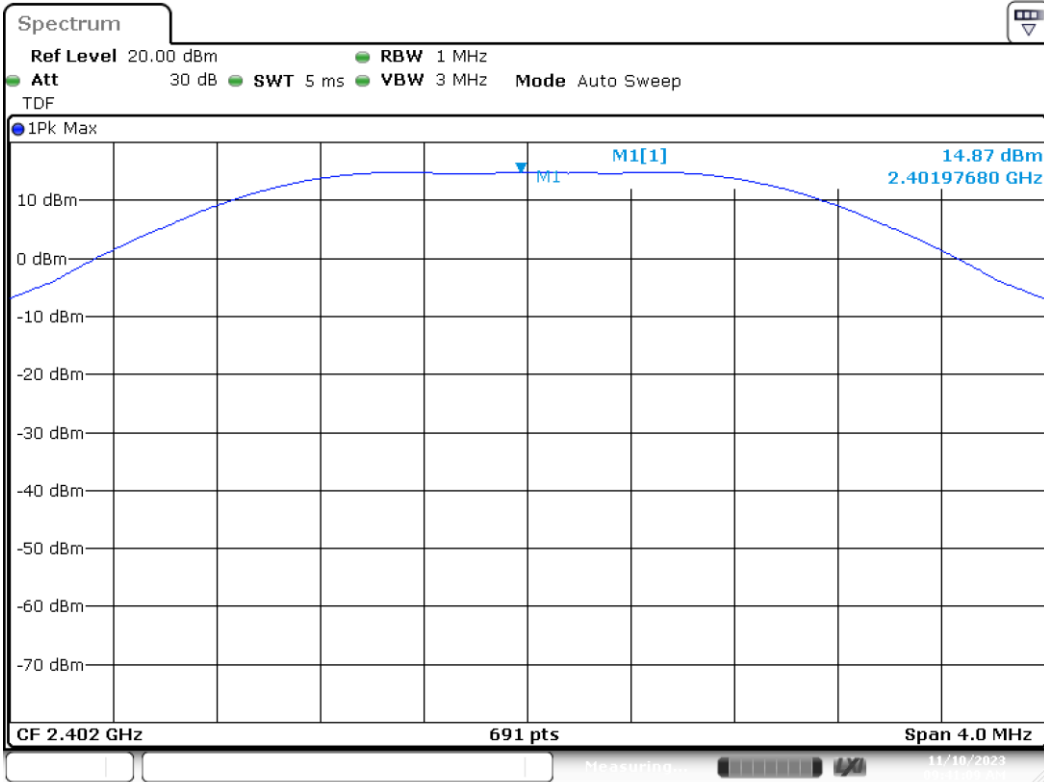

Date: 10.NOV.2023 09:41:10

#### Max Power RMS – 2402 MHz

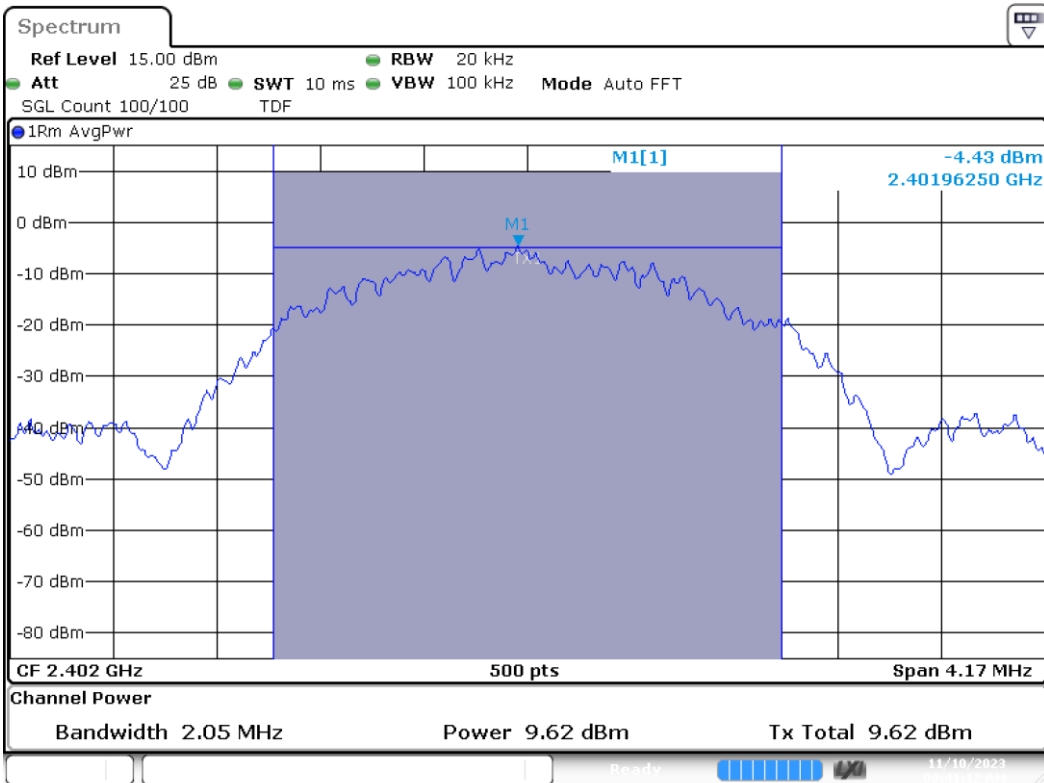

Date: 10.NOV.2023 09:41:13

# BLE

## Max Power Peak – 2440 MHz

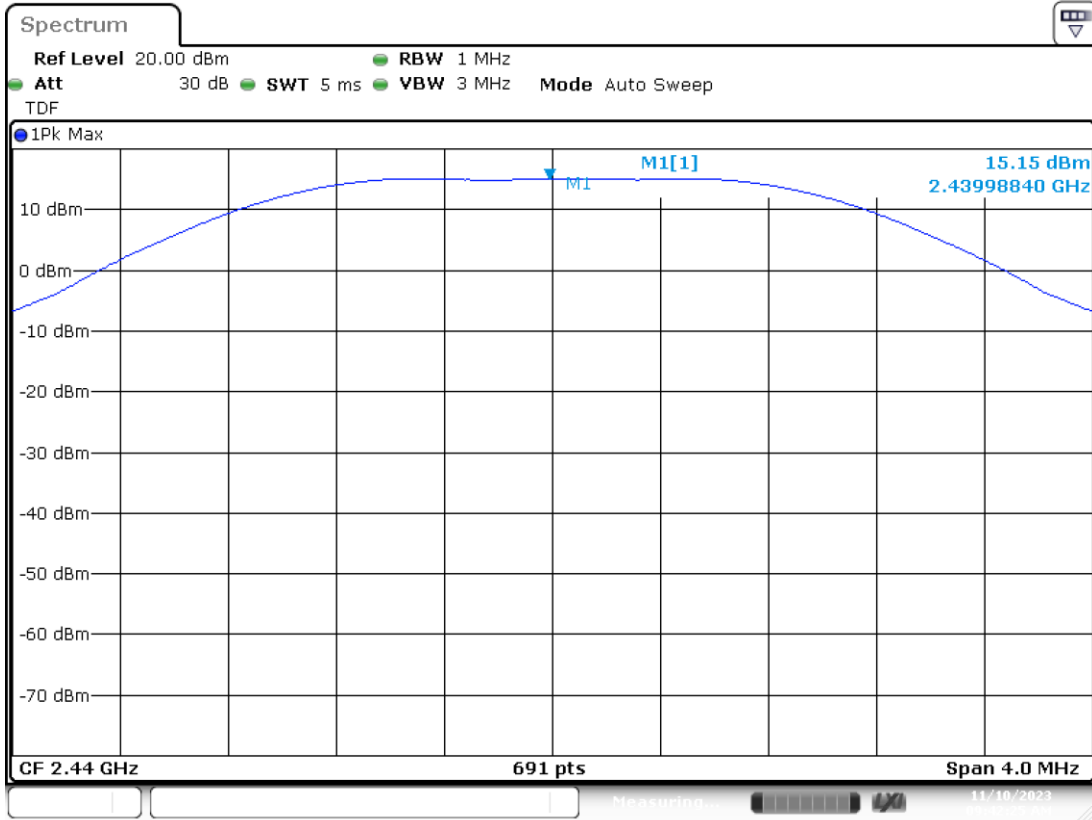

Date: 10.NOV.2023 09:42:26

## Max Power RMS – 2440 MHz

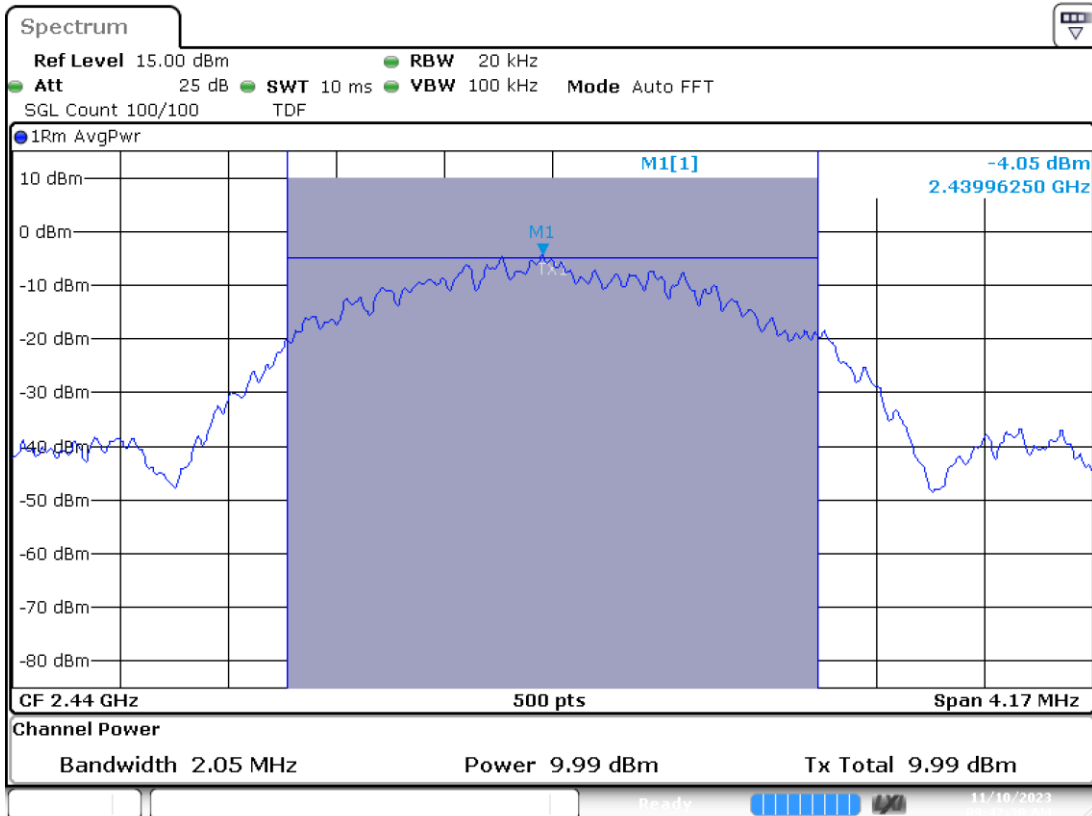

Date: 10.NOV.2023 09:42:30

# BLE

## Max Power Peak – 2480 MHz

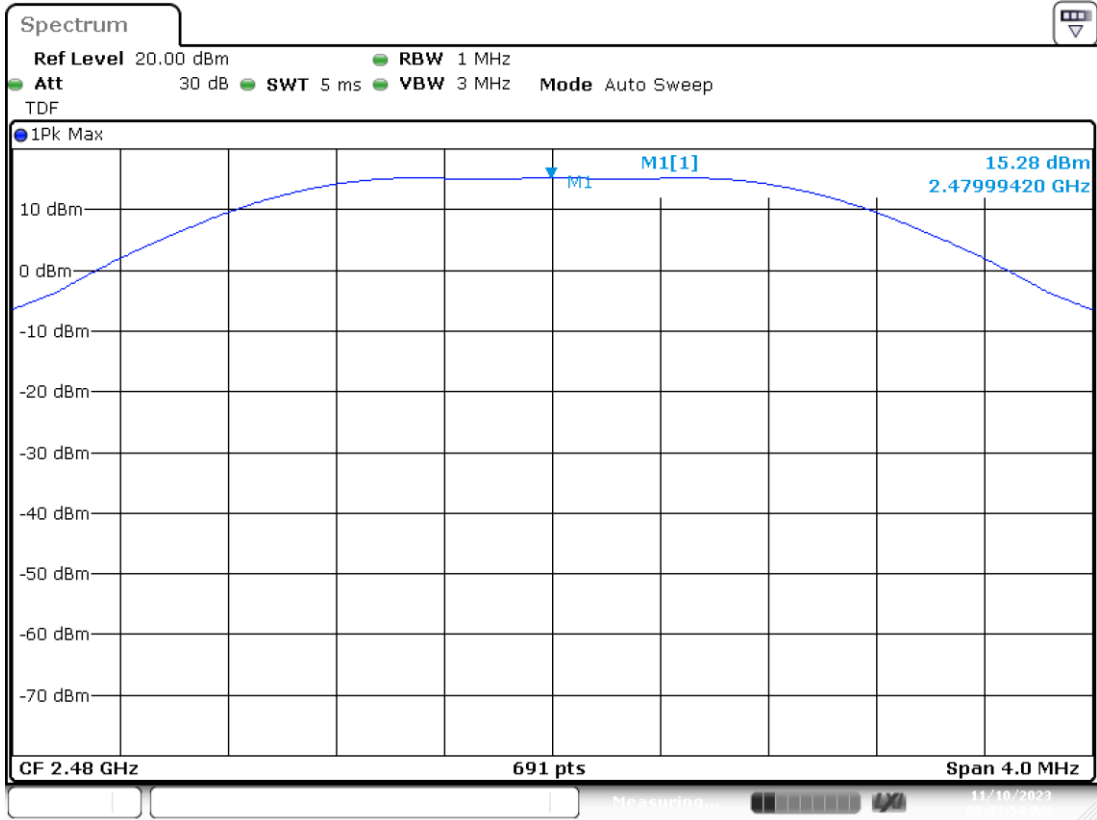

Date: 10.NOV.2023 09:43:54

## Max Power RMS – 2480 MHz

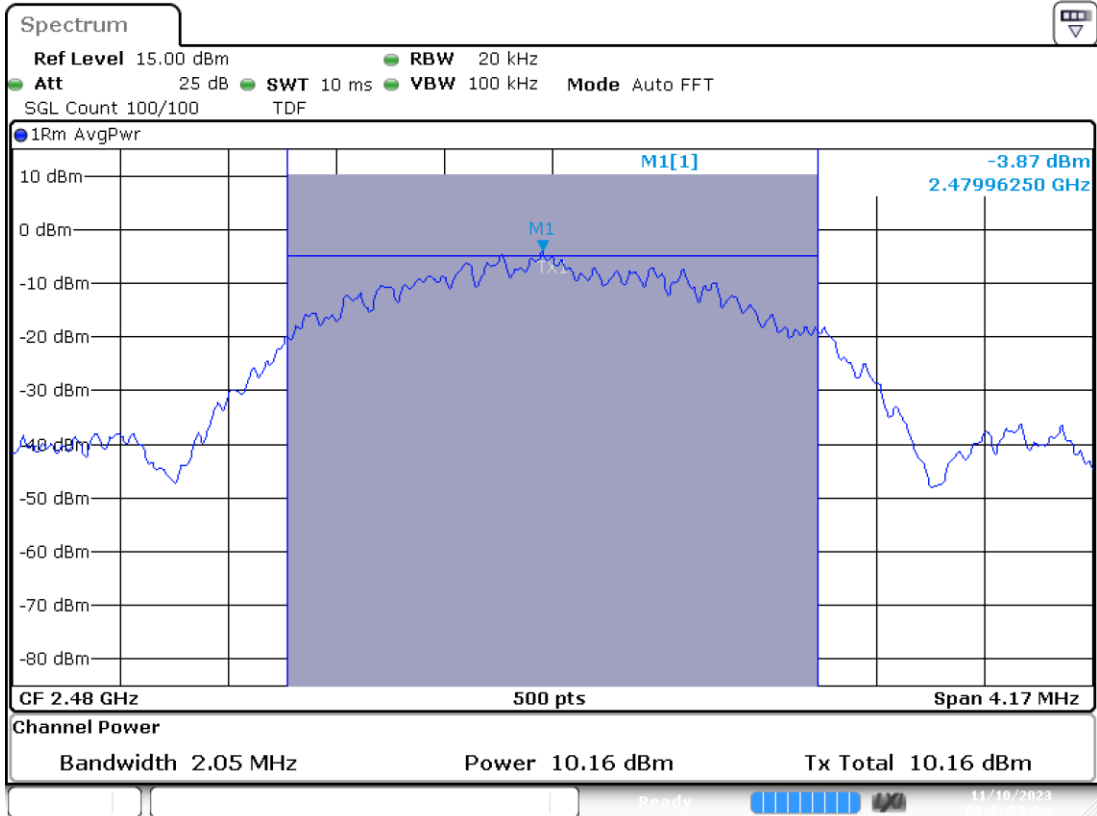

Date: 10.NOV.2023 09:43:58

### B.1.3 Power Spectral Density

#### Test limits

FCC part	RSS part	Limits
15.247 (e)	RSS-247 Clause 5.2 (b)	For digitally modulated systems, the power spectral density conducted from the intentional radiator to the antenna shall not be greater than 8 dBm in any 3 kHz band during any time interval of continuous transmission. This power spectral density shall be determined in accordance with the provisions of paragraph (b) of this section. The same method of determining the conducted output power shall be used to determine the power spectral density.

#### Test procedure

The maximum peak power spectral density level of the fundamental emission was measured using the method PKPSD, defined in paragraph 11.10.2 of ANSI C63.10-2013.

The conducted setup shown in section *Test & System Description* was used to measure the power spectral density. The antenna terminal of the EUT is connected to the spectrum through an attenuator, and the spectrum analyzer reading is compensated to include the RF path loss.

#### Results tables

Mode	Channel	Frequency [MHz]	PSD Peak [dBm/3kHz]
BLE	0	2402	-2.85
	19	2440	-2.48
	39	2480	-2.30

\*Note: these PSD<sub>Peak</sub> values are shown just as a reference for the compliance of the Out-of-band Measurements. Thus the RBW used for these measurements was 100kHz.

# BLE

## PSD Peak – 2402 MHz

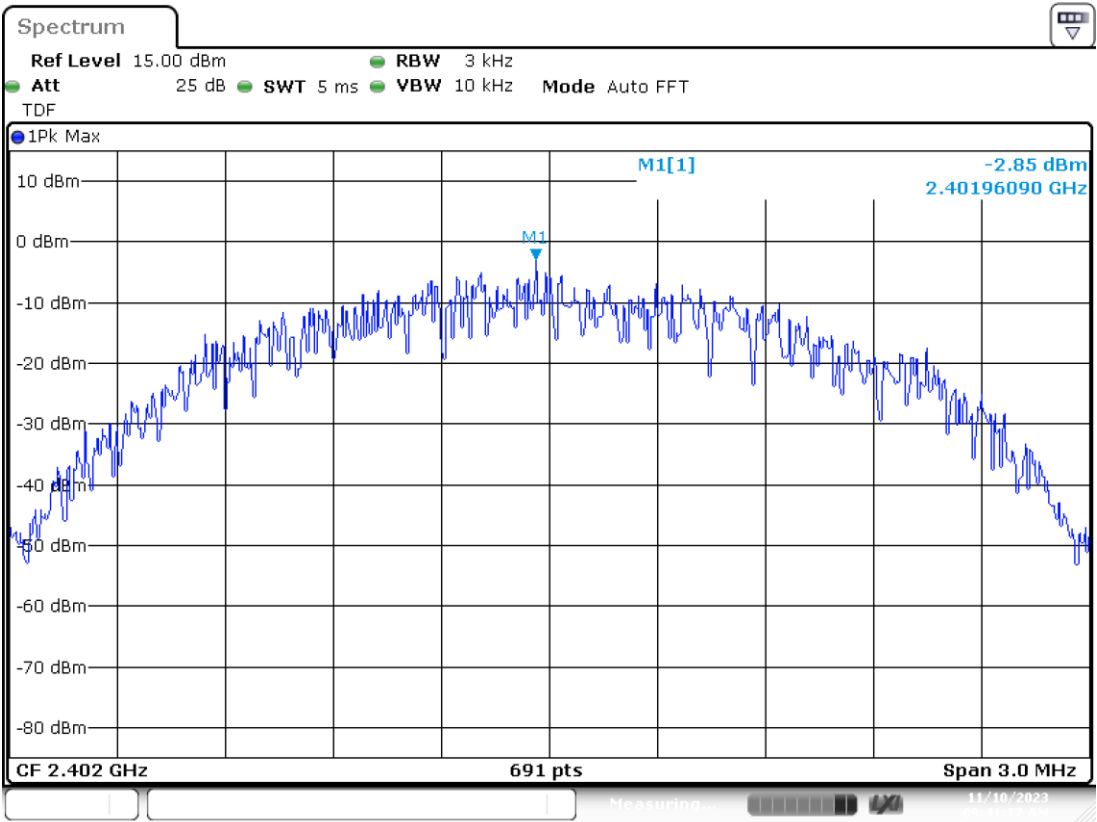

Date: 10.NOV.2023 09:41:17

## PSD Peak – 2440 MHz

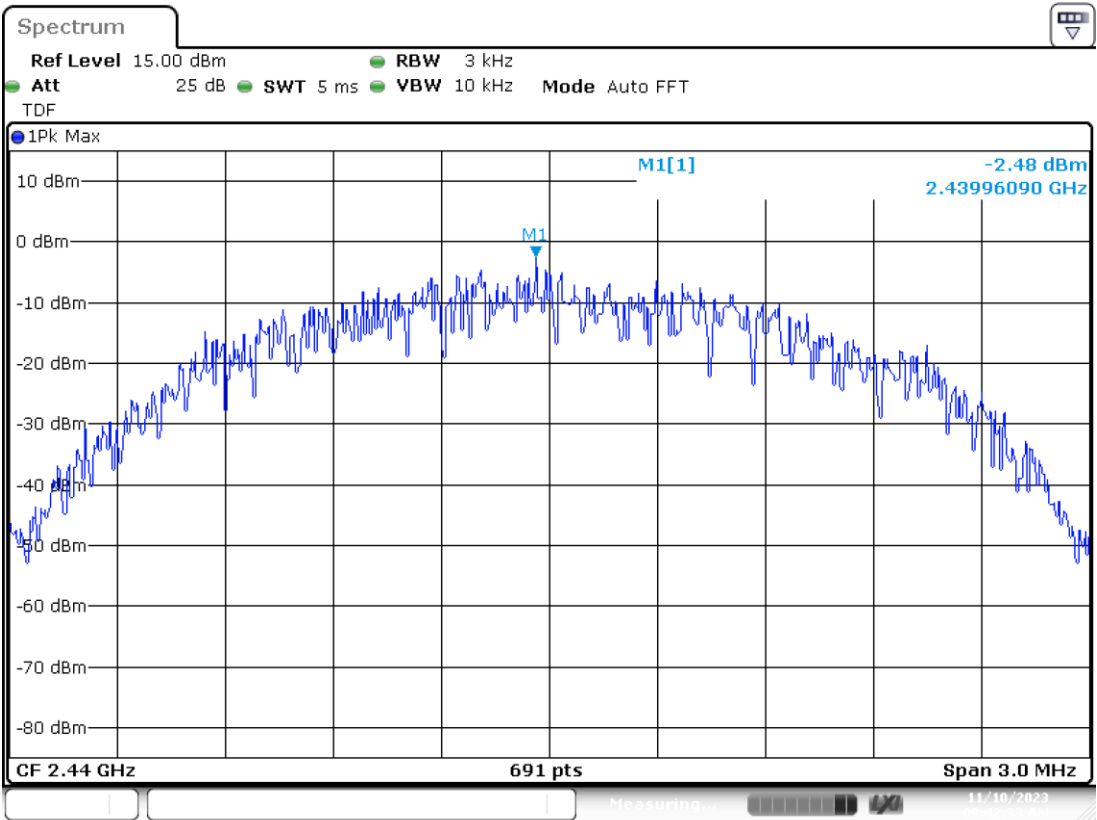

Date: 10.NOV.2023 09:42:33

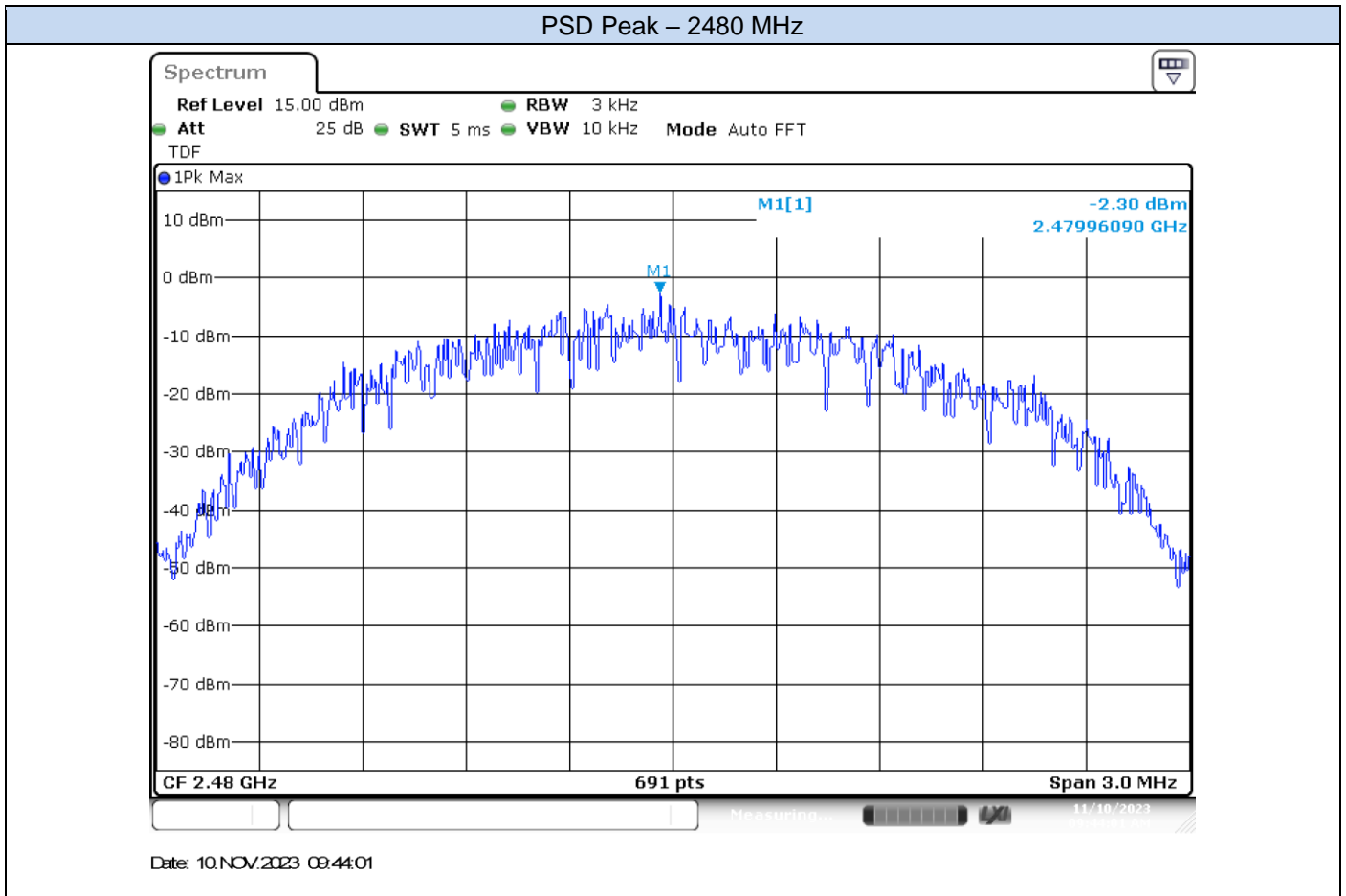

## B.1.4 Out-of-band emission (Conducted)

### Test Limits

FCC part	RSS part	Limits																				
15.247 (d)	RSS-247 Clause 5.5	In any 100 kHz bandwidth outside the frequency band in which the spread spectrum or digitally modulated intentional radiator is operating, the radio frequency power that is produced by the intentional radiator shall be at least 20 dB below that in the 100 kHz bandwidth within the band that contains the highest level of the desired power, based on either an RF conducted or a radiated measurement, provided the transmitter demonstrates compliance with the peak conducted power limits.																				
15.209	RSS-Gen A1 Clause 8.9	<p>Radiated emissions which fall in the restricted bands, as defined in §15.205(a), must also comply with the radiated emission limits specified in §15.209(a):</p> <table border="1"> <thead> <tr> <th>Freq Range (MHz)</th> <th>Field Strength (<math>\mu\text{V}/\text{m}</math>)</th> <th>Field Strength (<math>\text{dB}\mu\text{V}/\text{m}</math>)</th> <th>Meas. Distance (m)</th> </tr> </thead> <tbody> <tr> <td>30-88</td> <td>100</td> <td>40</td> <td>3</td> </tr> <tr> <td>88-216</td> <td>150</td> <td>43.5</td> <td>3</td> </tr> <tr> <td>216-960</td> <td>200</td> <td>46</td> <td>3</td> </tr> <tr> <td>Above 960</td> <td>500</td> <td>54</td> <td>3</td> </tr> </tbody> </table> <p>The emission limits shown in the above table are based on measurements employing CISPR quasi-peak detector except for the frequency bands 9-90 kHz, 110-490 kHz and above 1000 MHz. Radiated emission limits in these three bands are based on measurements employing an average detector. For average radiated emission measurements above 1000 MHz, there is also a limit specified when measuring with peak detector function, corresponding to 20 dB above the indicated values in the table.</p>	Freq Range (MHz)	Field Strength ( $\mu\text{V}/\text{m}$ )	Field Strength ( $\text{dB}\mu\text{V}/\text{m}$ )	Meas. Distance (m)	30-88	100	40	3	88-216	150	43.5	3	216-960	200	46	3	Above 960	500	54	3
Freq Range (MHz)	Field Strength ( $\mu\text{V}/\text{m}$ )	Field Strength ( $\text{dB}\mu\text{V}/\text{m}$ )	Meas. Distance (m)																			
30-88	100	40	3																			
88-216	150	43.5	3																			
216-960	200	46	3																			
Above 960	500	54	3																			

### Test procedure

In case of band edge measurements falling in restricted bands, the declared Antenna Gain is also compensated in the graph.

For band edge measurements falling in restricted bands, the following limits in dBm were applied for the average detector after the conversion from the limits detailed above in  $\text{dB}\mu\text{V}/\text{m}$ , according to FCC 47 CFR part 15 - Subpart C – §15.209(a). The limits in dBm for peak detector are 20dB above the indicated values in the table.

§15.209(a)			Converted values	
Freq Range (MHz)	Distance (m)	Field strength (microvolts/meter)	Field strength (dB microvolts/meter)	Power (dBm)
Above 960	3	500	54.0	-41.2

The conducted setup shown in section *Test & System Description* was used to measure the out-of-band emissions. The antenna terminal of the EUT is connected to the spectrum through an attenuator, and the spectrum analyzer reading is compensated to include the RF path loss.

Note: For the compliance of the out-of-band Measurements,  $\text{PSD}_{\text{Peak}}$  were measured with 100kHz RBW and values are shown just as a reference in section B.1.3.

## BLE

### BE Low (Non Restricted) – 2402 MHz

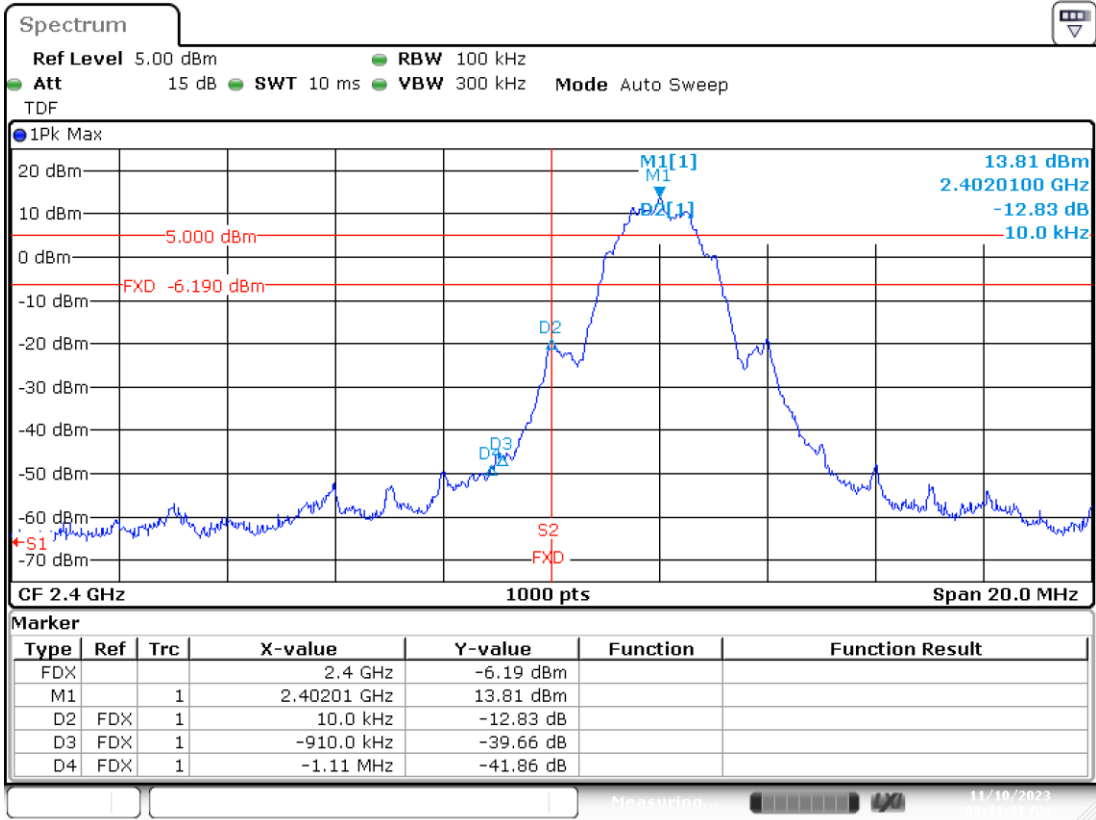

Date: 10.NOV.2023 09:41:41

### BE Low (Restricted) – 2402 MHz

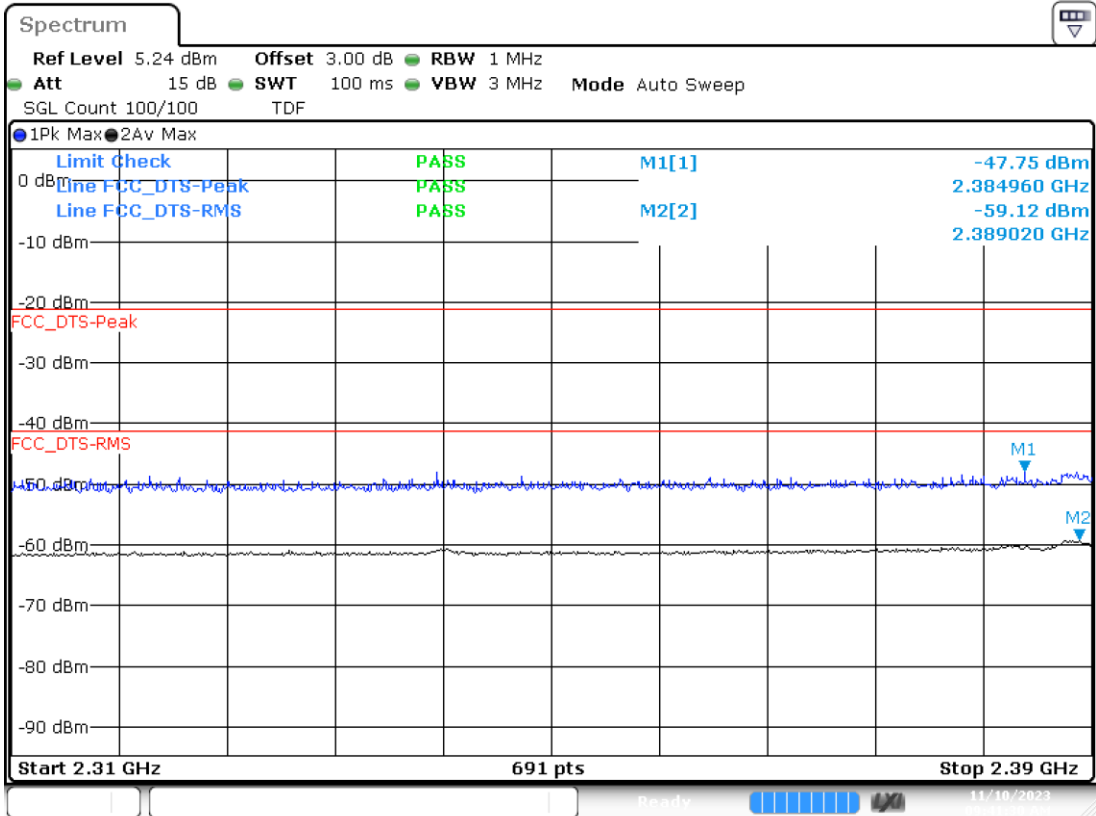

Date: 10.NOV.2023 09:41:30



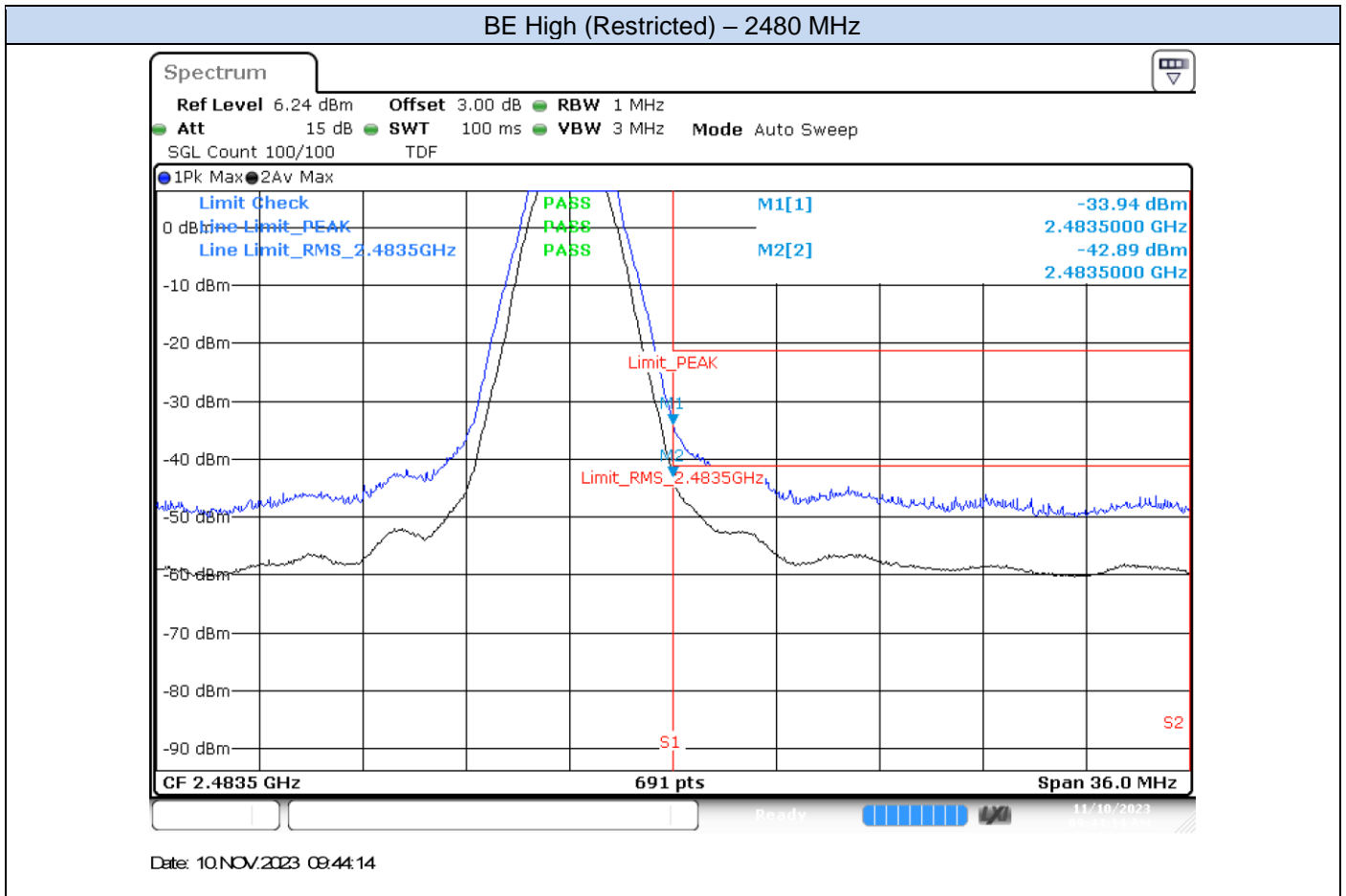

### B.1.5 Radiated spurious emission

Standards references

FCC part	RSS part	Limits																					
<p>15.247 (d) 15.209</p>	<p>RSS-247 Clause 5.5 RSS-Gen A1 Clause 8.9</p>	<p>Radiated emissions which fall in the restricted bands, as defined in §15.205(a), must also comply with the radiated emission limits specified in §15.209(a):</p>																					
		<table border="1"> <thead> <tr> <th data-bbox="630 472 783 535">Freq Range (MHz)</th> <th data-bbox="788 472 1023 535">Field Strength (μV/m)</th> <th data-bbox="1027 472 1219 535">Field Strength (dBμV/m)</th> <th data-bbox="1224 472 1418 535">Meas. Distance (m)</th> </tr> </thead> <tbody> <tr> <td data-bbox="630 542 783 573">30-88</td> <td data-bbox="788 542 1023 573">100</td> <td data-bbox="1027 542 1219 573">40</td> <td data-bbox="1224 542 1418 573">3</td> </tr> <tr> <td data-bbox="630 580 783 611">88-216</td> <td data-bbox="788 580 1023 611">150</td> <td data-bbox="1027 580 1219 611">43.5</td> <td data-bbox="1224 580 1418 611">3</td> </tr> <tr> <td data-bbox="630 618 783 649">216-960</td> <td data-bbox="788 618 1023 649">200</td> <td data-bbox="1027 618 1219 649">46</td> <td data-bbox="1224 618 1418 649">3</td> </tr> <tr> <td data-bbox="630 656 783 687">Above 960</td> <td data-bbox="788 656 1023 687">500</td> <td data-bbox="1027 656 1219 687">54</td> <td data-bbox="1224 656 1418 687">3</td> </tr> </tbody> </table>	Freq Range (MHz)	Field Strength (μV/m)	Field Strength (dBμV/m)	Meas. Distance (m)	30-88	100	40	3	88-216	150	43.5	3	216-960	200	46	3	Above 960	500	54	3	
Freq Range (MHz)	Field Strength (μV/m)	Field Strength (dBμV/m)	Meas. Distance (m)																				
30-88	100	40	3																				
88-216	150	43.5	3																				
216-960	200	46	3																				
Above 960	500	54	3																				
<p>The emission limits shown in the above table are based on measurements employing CISPR quasi-peak detector except for the frequency bands above 1000 MHz. Radiated emission limits in these three bands are based on measurements employing an average detector. For average radiated emission measurements above 1000 MHz, there is also a limit specified when measuring with peak detector function, corresponding to 20 dB above the indicated values in the table.</p>																							

Test procedure

The radiated setups shown in section *Test & System Description* were used to measure the radiated spurious emissions.

Depending of the frequency range and bands being tested, different antennas and filters were used.

The final measurement is done by varying the antenna height from 1 m to 4 m, the EUT azimuth over 360° and for both Vertical and Horizontal polarizations.

The radiated spurious emission was measured on the worst case configuration found.

## Test Results

## Radiated spurious - 30 MHz to 1 GHz

## All modes

Frequency	Level	Detector	Limit	Margin	Polar
MHz	dBµV/m	---	dBµV/m	dB	---
32.5	32.3	Quasi-Peak	40.0	7.7	V
47.9	32.7	Quasi-Peak	40.0	7.3	V
87.4	34.3	Quasi-Peak	40.0	5.7	V

Note 1: The spurious signals detected do not depend on either the operating channel or the modulation mode.

## 1 GHz – 26 GHz, BLE

## Radiated Spurious – 2402 MHz

Frequency	Level	Detector	Limit	Margin	Polar
MHz	dBµV/m	---	dBµV/m	dB	---
6008.1	55.4	Peak	74.0	18.6	V
6008.1	42.7	Average	54.0	11.3	V
10500.0	49.1	Peak	74.0	24.9	V
10500.0	42.9	Average	54.0	11.1	V

## Radiated Spurious – 2440 MHz

Frequency	Level	Detector	Limit	Margin	Polar
MHz	dBµV/m	---	dBµV/m	dB	---
5493.1	41.0	Average	54.0	13.0	H
5525.0	54.0	Peak	74.0	20.0	H
10500.0	50.2	Peak	74.0	23.8	V
10500.0	42.6	Average	54.0	11.4	V

## Radiated Spurious – 2480 MHz

Frequency	Level	Detector	Limit	Margin	Polar
MHz	dBµV/m	---	dBµV/m	dB	---
3370.0	51.8	Peak	74.0	22.2	V
3394.5	40.6	Average	54.0	13.4	V
10500.0	49.6	Peak	74.0	24.4	V
10500.0	43.4	Average	54.0	10.6	V