



TEST REPORT

EUT Description	WLAN and BT, 2x2 PCIe M.2 1216 adapter card
Brand Name	Intel®
Model Name	BE201D2W
FCC/IC ID	PD9BE201D2 ; 1000M-BE201D2
Date of Test Start/End	2024-01-10 / 2024-02-16
Features	2x2 WiFi - Bluetooth® (see section 5)

Applicant	Intel Corporation SAS
Address	425 Rue de Goa – Le Cargo B6 – 06600 Antibes, FRANCE
Contact Person	Benjamin Lavenant
Telephone/Fax/ Email	Benjamin.lavenant@intel.com

Reference Standards	FCC Title 47 CFR part 15 - Subpart C RSS-247 issue 3, RSS-Gen A1 issue 5 - A1 (see section 1)
---------------------	---

Test Report identification	231120-06.TR06
Revision Control	Rev. 00 This test report revision replaces any previous test report revision (see section 8)

The test results relate only to the samples tested.
Reference to accreditation shall be used only by full reproduction of test report.

Issued by

Reviewed by

Robin Luciani
(Test Engineer Lead)

Zayd OUACHICHA
(Technical Manager)

Intel Corporation S.A.S – WRF Lab
425 rue de Goa – Le Cargo B6 - 06600, Antibes, France
Tel. +33493001400 / Fax +33493001401

Table of Contents

1. Standards, reference documents and applicable test methods	3
2. General conditions, competences and guarantees	3
3. Environmental Conditions	3
4. Test samples	4
5. EUT Features	5
6. Remarks and comments	5
7. Test Verdicts summary	6
8. Document Revision History	6
Annex A. Test & System Description	7
A.1 MEASUREMENT SYSTEM	7
A.2 TEST EQUIPMENT LIST	9
A.3 MEASUREMENT UNCERTAINTY EVALUATION	10
Annex B. Test Results	11
B.1 20DB BANDWIDTH AND CARRIER FREQUENCY SEPARATION	11
B.1.1 Test limits	11
B.1.2 Results tables	11
B.1.3 Results screenshot	12
B.2 NUMBER OF HOPPING CHANNELS	15
B.2.1 Test limits	15
B.2.2 Test procedure	15
B.2.3 Results tables	15
B.3 TIME OF OCCUPANCY (DWELL TIME)	19
B.3.1 Test procedure	19
B.3.2 Results tables	19
B.3.3 Results Screenshot	20
B.4 MAXIMUM PEAK OUTPUT POWER ANTENNA GAIN	25
B.4.1 Test Limits	25
B.4.2 Test procedure	25
B.4.3 Results tables	25
B.4.4 Results Screenshot	26
B.5 OUT-OF-BAND EMISSION (CONDUCTED)	28
B.5.1 Test limits	28
B.5.2 Test procedure	28
B.5.3 Test results	29
B.6 RADIATED SPURIOUS EMISSION	38
B.6.1 Standards references	38
B.6.2 Test procedure	38
Annex C. Photographs	43
C.1 TEST SETUP	43
C.2 TEST SAMPLE	45

1. Standards, reference documents and applicable test methods

FCC	<ol style="list-style-type: none"> 1. FCC Title 47 CFR part 15 - Subpart C – §15.247 Operation within the bands 902-928 MHz, 2400-2483.5 MHz, and 5725-5850 MHz. 2021-10-01 Edition 2. FCC Title 47 CFR part 15 - Subpart C – §15.209 Radiated emission limits; general requirements. 2021-10-01 Edition 3. FCC OET KDB 558074 D01 v05r02 - Guidance for compliance measurements on digital transmission system, frequency hopping spread spectrum system, and hybrid system devices operating under section 15.247 of the FCC rules. 4. FCC OET KDB 662911 D01 v02r01 - Emissions Testing of Transmitters with Multiple Outputs in the Same Band. 5. ANSI C63.10-2013 - American National Standard of Procedures for Compliance Testing of Unlicensed Wireless Devices
ISED	<ol style="list-style-type: none"> 1. RSS-247 Issue 3 - Digital Transmission Systems (DTSs), Frequency Hopping Systems (FHSs) and License-Exempt Local Area Network (LE-LAN) Devices. 2. RSS-Gen Issue 5 A1- General Requirements for Compliance of Radio Apparatus. 3. FCC OET KDB 558074 D01 v05r02 - Guidance for compliance measurements on digital transmission system, frequency hopping spread spectrum system, and hybrid system devices operating under section 15.247 of the FCC rules. 4. FCC OET KDB 662911 D01 v02r01 - Emissions Testing of Transmitters with Multiple Outputs in the Same Band. 5. ANSI C63.10-2013 - American National Standard of Procedures for Compliance Testing of Unlicensed Wireless Devices

2. General conditions, competences and guarantees

- ✓ Tests performed under FCC standards identified in section 1 are covered by A2LA accreditation.
- ✓ Tests performed under ISED standards identified in section 1 are covered by Cofrac accreditation.
- ✓ Intel Corporation SAS Wireless RF Lab (Intel WRF Lab) is an ISO/IEC 17025:2017 laboratory accredited by the American Association for Laboratory Accreditation (A2LA) with the certificate number 3478.01.
- ✓ Intel Corporation SAS Wireless RF Lab (Intel WRF Lab) is an Accredited Test Firm recognized by the FCC, with Designation Number FR0011.
- ✓ Intel Corporation SAS Wireless RF Lab (Intel WRF Lab) is an ISO/IEC 17025:2017 testing laboratory accredited by the French Committee for Accreditation (Cofrac) with the certificate number 1-6736.
- ✓ Intel Corporation SAS Wireless RF Lab (Intel WRF Lab) is a Registered Test Site listed by ISED, with ISED company number 1000Y and CAB identifier FR0005.
- ✓ Intel WRF Lab only provides testing services and is committed to providing reliable, unbiased test results and interpretations.
- ✓ Intel WRF Lab is liable to the client for the maintenance of the confidentiality of all information related to the item under test and the results of the test.
- ✓ Intel WRF Lab has developed calibration and proficiency programs for its measurement equipment to ensure correlated and reliable results to its customers.
- ✓ This report is only referred to the item that has undergone the test.
- ✓ This report does not imply an approval of the product by the Certification Bodies or competent Authorities.

3. Environmental Conditions

- ✓ At the site where the measurements were performed the following limits were not exceeded during the tests:

Temperature	23.4+/-0.5°C
Humidity	36.4+/-3.2%

4. Test samples

Sample	Control #	Description	Model	Serial #	Date of receipt	Note
#01	231120-05.S13	WiFi 7 Module	BE201D2W	F8FE5ECDCA67	2024-02-06	Used for RF conducted tests
	200904-01.S10	Laptop	HP Opel	000075059C	2023-04-24	
	231109-03.S46	Extender Board	CRF DB 2230 BNJ	2202227961	2023-11-16	
#02	231120-05.S03	WiFi 7 Module	BE201D2W	60452EB8A3BC	2024-01-05	Used for Radiated Spurious Emissions tests
	220225-03.S07	Microwave Absorber	Eccosorb BSR-1	-	2022-03-14	
	231109-03.S48	Adaptor	PCB00866-00_A	124627	2023-11-24	
	200611-03.S31	Extender	ADEXELEC	-	2020-08-19	
	200504-04.S07	Laptop	Latitude 5401	BVHLK13	2020-06-02	
	230223-02.S47	Triband Antenna	-	005	2023-04-20	
	230223-02.S48	Triband Antenna	-	006	2023-04-20	
	231120-05.S21	WiFi 7 Module	BE201D2W	F8FE5CDCA49	2024-02-07	
	180001-01.S21	Socket	1216SD to M.2	-	2021-06-07	
#03	231120-05.S02	WiFi 7 Module	BE201D2W	60452EB8A407	2024-01-05	Used for Radiated Spurious Emissions tests
	220225-03.S07	Microwave Absorber	Eccosorb BSR-1	-	2022-03-14	
	231109-03.S47	Adaptor	PCB00866-00_A	124727	2023-11-24	
	220915-09.S01	Extender	ADEXELEC	-	2022-04-06	
	200611-03.S30	Laptop	Latitude 5401	6DJLK13	2020-08-19	
	230223-02.S49	Triband Antenna	-	007	2023-04-20	
	230223-02.S50	Triband Antenna	-	008	2023-04-20	
	231120-05.S20	WiFi 7 Module	BE201D2W	F8FE5ECDCA43	2024-02-07	
	180001-01.S21	Socket	1216SD to M.2	-	2021-06-07	

5. EUT Features

The herein information is provided by the customer

Intel WRF Lab declines any responsibility for the accuracy of the stated customer provided information, especially if it has any impact on the correctness of test results presented in this report.

Brand Name	Intel®		
Model Name	BE201D2W		
Software Version	DRTU.05312.99.0.85 / RFC : DRTU.05726.99.0.86		
Driver Version	99.0.86.3 / RFC : 23.10.23361.24681		
Prototype / Production	Production		
Supported Radios	802.11b/g/n/ac/ax/be	2.4GHz	
	802.11a/n/ac/ax/be	5.2GHz	
		5.6GHz	
		5.8GHz	
	802.11ax/be	6.0GHz	
Antenna Information	Bluetooth	2.4GHz	
	Transmitter	Chain A(1)	Chain B(2)
	Manufacturer	Intel WRF Lab	Intel WRF Lab
	Antenna type	PIFA	PIFA
	Part number	WRF-Tri Band-Antenna	WRF-Tri Band-Antenna
Antenna peak gain (dBi)	+3	+3	

6. Remarks and comments

1. No deviations were made from the test methods listed in section 1 of this report
2. Bluetooth tests have been performed on Chain A (1)

7. Test Verdicts summary

The statement of conformity to applicable standards in the table below are based on the measured values, without taking into account the measurement uncertainties.

FCC part	RSS part	Test name	Verdict
15.247 (a) (1)	RSS-247 Clause 5.1 (a) and (b)	20dB Bandwidth and Carrier frequency separation	P
15.247 (a) (1) (iii)	RSS-247 Clause 5.1 (d)	Number of hopping channels	P
15.247 (a) (1) (iii)	RSS-247 Clause 5.1 (d)	Time of Occupancy (Dwell Time)	P
15.247 (b) (1)	RSS-247 Clause 5.4 (b)	Maximum Peak Output Power and antenna gain	P
15.247 (d)	RSS-247 Clause 5.5	Out-of-band Emissions (conducted)	P
15.247 (d) 15.209	RSS-247 Clause 5.5 RSS-Gen A1 Clause 8.9	Spurious Emissions (radiated)	P

P: Pass

F: Fail

NM: Not Measured

NA: Not Applicable

8. Document Revision History

Revision #	Modified by	Revision Details
Rev. 00	K.KHATIB T.MATHIEU	First Issue

Annex A. Test & System Description

A.1 Measurement System

Measurements were performed using the following setups.

The DUT was installed in a test fixture and this test fixture is connected to a laptop computer and AC/DC power adapter. The laptop computer was used to configure the EUT to continuously transmit at a specified output power using all different modes and modulation schemes.

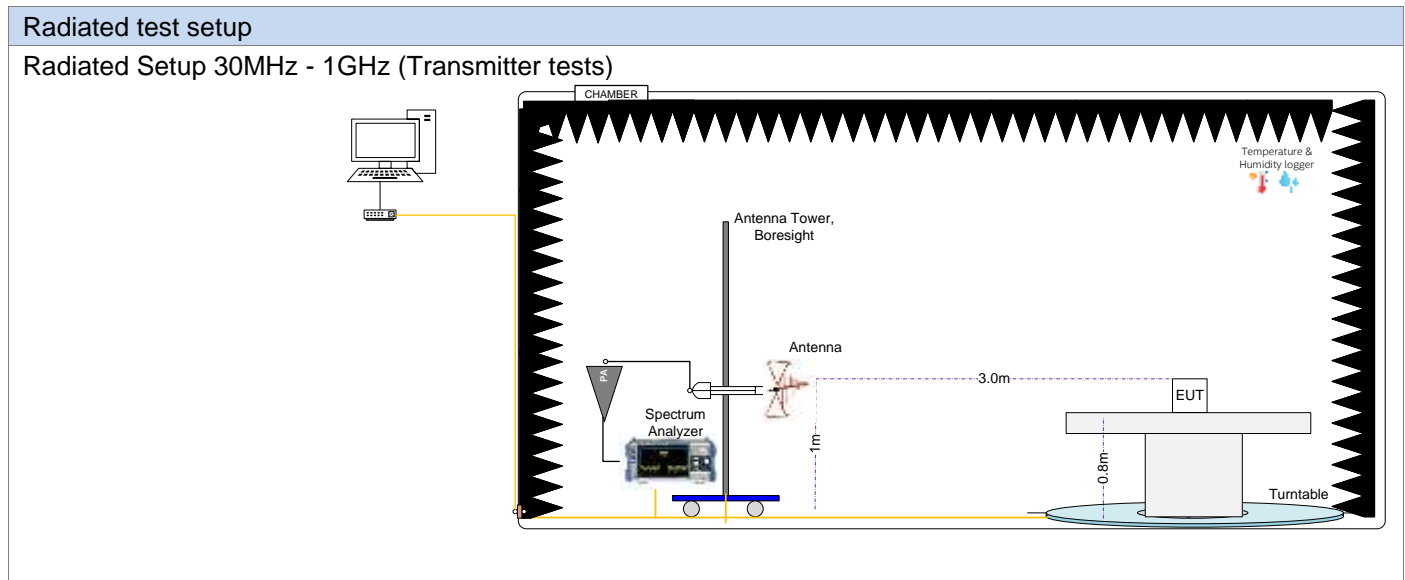
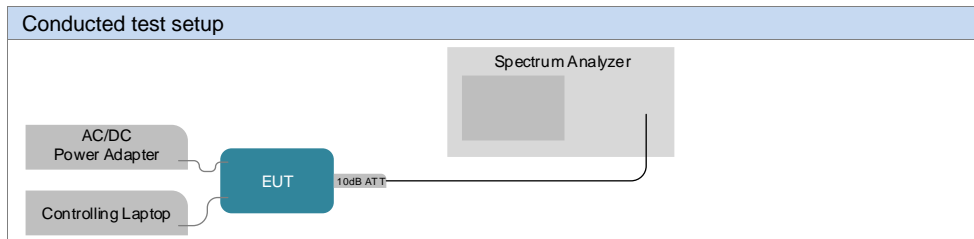

Radiated Setup 1GHz – 11GHz (Transmitter tests)

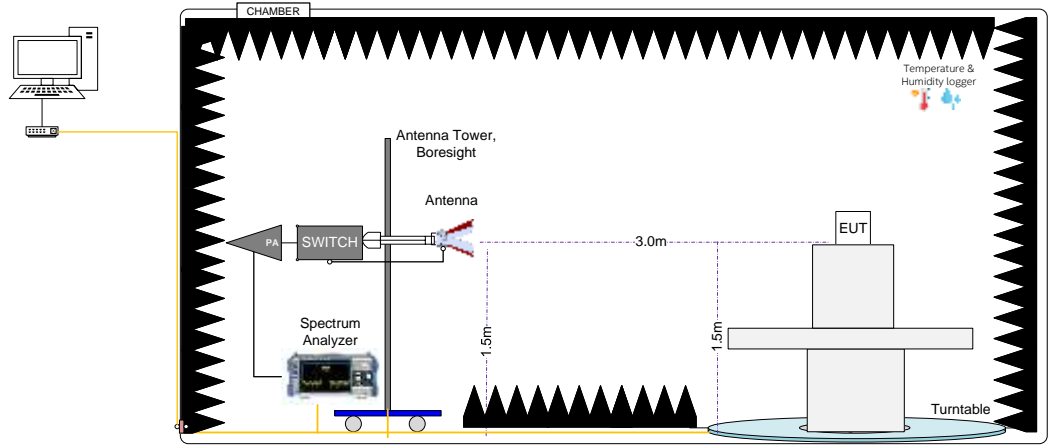

Radiated Setup 11GHz – 26GHz (Transmitter tests)

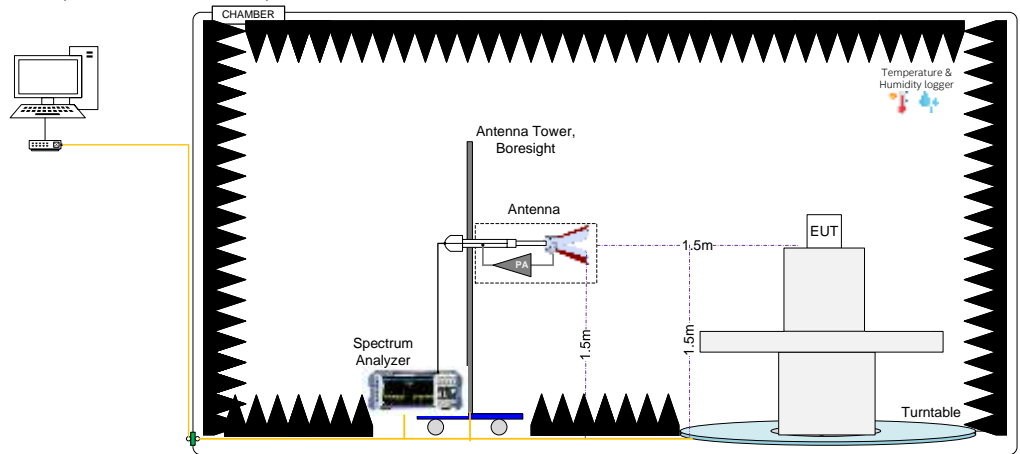

Sample Calculation

The spurious received voltage V (dB μ V) in the spectrum Analyzer is converted to Electric field strength using the transducer factor F corresponding to the Rx path Loss:

$$F \text{ (dB/m)} = \text{Rx Antenna Factor (dB/m)} + \text{Cable losses (dB)} - \text{Amplifiers Gain (dBi)}$$

$$E \text{ (dB}\mu\text{V)} = V \text{ (dB}\mu\text{V)} + F \text{ (dB/m)}$$

For field strength measurements made at other than the distance at which the applicable limit is specified, the field strength of the emission at the distance specified by the limit is deduced as follows:

$$E_{\text{SpecLimit}} = E_{\text{Meas}} + 20 \cdot \log(D_{\text{Meas}}/D_{\text{SpecLimit}})$$

where

$E_{\text{SpecLimit}}$ is the field strength of the emission at the distance specified by the limit, in dB μ V/m

E_{Meas} is the field strength of the emission at the measurement distance, in dB μ V/m

D_{Meas} is the measurement distance, in m

$D_{\text{SpecLimit}}$ is the distance specified by the limit, in m

A.2 Test Equipment List

Conducted setup

ID#	Device	Type/Model	Serial #	Manufacturer	Cal. Date	Cal. Due Date
159-000	Spectrum Analyzer	FSV40	101072	Rohde & Schwarz	2023-03-23	2025-03-23
019-000	RF cable 100cm	PE360-100	N/A	PASTERNAK	2023-03-03	2024-03-03
019-002	10dB Attenuator + MH4	PE7395-10	N/A	PASTERNAK	2023-03-03	2024-03-03
363-000	Temp & Humidity Logger	RA12E-TH1-RAS	RA12-D0EB1A	AVITECH	2023-09-28	2025-09-28
413-000	Measurement SW v1.5.4.2	Octopi	N/A	Step AT	N/A	N/A

Radiated Setup #1

ID#	Device	Type/Model	Serial #	Manufacturer	Cal. Date	Cal. Due Date
006-000*	Anechoic Chamber	FACT3	5720	ETS-Lindgren	2022-01-21	2024-02-21
006-008	Measurement SW, v11.30	EMC32	100623	Rohde & Schwarz	N/A	N/A
259-000	Temp & Humidity Logger	RA12E-TH-RAS	RA12-B9BD70	Avtech	2022-06-27	2024-06-27
006-001	Turn Table	ETS	-	ETS-Lindgren	N/A	N/A
006-011	Boresight antenna mast	BAM 4.0-P	P/278/2890.01	Maturo	N/A	N/A
007-008	Double Horn Ridged antenna +PA	3116C-PA	00169308bis + 00196308	ETS-Lindgren	2023-0-30	2025-05-30
057-000	Double Horn Ridged antenna	3117	167062	ETS-Lindgren	2022-07-08	2024-07-08
058-000	Double Horn Ridged antenna	3116C	157511	ETS-Lindgren	2022-10-21	2024-10-21
006-061	Bi-Log Periodic antenna	CBL6143A	61382	Teseq	2022-10-24	2024-10-24
147-000	Spectrum analyzer	FSW43	101847	Rohde & Schwarz	2022-11-30	2024-11-30
301-000	Amplifier 9kHz-1300MHz	8447F	3113A07440	HP	2023-03-03	2024-03-03
261-000	Amplifier 1GHz-18GHz	3117-PA	00157993	ETS-Lindgren	2023-02-20	2024-02-20
502-006	Amplifier 0.5GHz-40GHz	DEPA0540-43	2023A05	Diamond Engineering	2023-06-09	2024-06-09
009-007	RF Filter	ZHSS-k11G+	8493 1831830	Mini-Circuits	2023-06-09	2024-06-09
006-068	RF Switch	RC-2SP6T-40	02112090061	Micro-Circuits	2023-08-22	2024-08-22
006-066	Cable 7m – 25MHz to 40GHz	R286304174	20.46.370	Radiall	2023-08-16	2024-08-16
006-063	Cable 30cm – 1GHz to 40GHz	PE371-12	-	Pasternack	2023-02-27	2024-02-27
006-064	Cable 30cm – 1GHz to 40GHz	PE371-12	-	Pasternack	2023-02-27	2024-02-27
006-065	Cable 60cm – 25MHz to 1GHz	PE300-24	-	Pasternack	2023-06-02	2024-06-02

N/A: Not Applicable

*Within a grace period of 30 days

Radiated Setup #2

ID#	Device	Type/Model	Serial #	Manufacturer	Cal. Date	Cal. Due Date
007-000	Anechoic chamber	RFD-FA-100	5996	ETS Lindgren	2021-09-14	2024-03-14
127-000	Spectrum Analyzer	FSV40	101358	Rohde & Schwarz	2023-01-27	2025-01-27
007-007	Double Ridge Horn (1- 18GHz)	3117	00152266	ETS Lindgren	2022-03-29	2024-03-29
007-006	Switch & Positioner	EMCenter	00151232	ETS Lindgren	N/A	N/A
059-000	Double Ridge Horn (1- 18GHz)	3117	201542	ETS-Lindgren	2023-09-26	2025-09-26
264-000	Amplifier 1GHz-18GHz	3117-PA	00169546	ETS-Lindgren	2023-02-20	2024-02-20
007-011	RF Cable 1-18GHz - 6.5m	140-8500-11-51	001	Atem	2023-02-15	2024-02-15
007-005	Measurement SW, v11.20.00	EMC32	100401	Rohde & Schwarz	N/A	N/A
007-003	Antenna Tower	2171B-3.0M	00150123	ETS Lindgren	N/A	N/A
007-002	Turntable	-	-	ETS Lindgren	N/A	N/A
007-014*	RF Cable 18-40 GHz 6m	R286304009	1747364	Radiall	2023-02-16	2024-03-16
007-022*	RF Cable 1-18GHz, 1.5m	0501050991200GX	19.23.493	Radiall	2023-02-13	2024-03-13
007-015*	RF Cable 1GHz-18GHz 1.5m	-	-	Spirent	2023-02-13	2024-03-13
007-018*	RF Cable 1-9.5GHz 1.2m	0500990991200KE	-	Radiall	2023-02-13	2024-03-13
007-020*	RF Cable 1-18GHz, 1.2 m	2301761761200PJ	12.22.1104	Radiall	2023-02-15	2024-03-15
349-000	Temp & Humidity Logger	RA12E-TH1-RAS	RA12-D4F8C3	Avtech	2023-11-30	2025-11-30

N/A: Not Applicable

*Within a grace period of 30 days

Shared Radiated Equipment

ID#	Device	Type/Model	Serial #	Manufacturer	Cal. Date	Cal. Due Date
412-000	DRTU Power finder V2.1	-	-	Intel	NA	NA
139-000	Power Sensor	NRP-Z81	104383	Rohde & Schwarz	2023-04-21	2025-04-21
061-000	Power Sensor	NRP-Z81	104386	Rohde & Schwarz	2022-03-25	2024-03-25
140-000	Power Sensor	NRP-Z81	104382	Rohde & Schwarz	2022-03-25	2024-03-25
423-000	Power Sensor	NRP-Z81	101152	Rohde & Schwarz	2022-05-18	2024-05-18

N/A: Not Applicable

A.3 Measurement Uncertainty Evaluation

The system uncertainty evaluation is shown in the table below with a coverage factor of $k = 2$ to indicate a 95% level of confidence:

Measurement type	Uncertainty	Unit
Timing	± 0.12	%
Power Spectral density	± 1.47	dB
Occupied bandwidth	± 2.07	%
Conducted Power	± 1.03	dB
Conducted Spurious Emission <26.5 GHz	± 2.93	dB
Radiated tests <1GHz	± 6.40	dB
Radiated tests 1GHz – 26.5 GHz	± 5.92	dB

Annex B. Test Results

The herein test results were performed by:

Test case measurement	Test Personnel
20dB Bandwidth and Carrier frequency separation	T.MATHIEU
Number of hopping channels	T.MATHIEU
Time of Occupancy (Dwell Time)	T.MATHIEU
Maximum Peak Output Power and antenna gain	T.MATHIEU
Out-of-band Emissions (conducted)	T.MATHIEU
Spirous Emissions (radiated)	K.KHATIB, R.SIMONINI

B.1 20dB Bandwidth and carrier frequency separation

B.1.1 Test limits

FCC part	RSS part	Limits
15.247 (a) (1)	RSS-247 Clause 5.1 (a) and (b)	Frequency hopping systems shall have hopping channel carrier frequencies separated by a minimum of 25 kHz or the 20 dB bandwidth of the hopping channel, whichever is greater. Alternatively, frequency hopping systems operating in the 2400-2483.5 MHz band may have hopping channel carrier frequencies that are separated by 25 kHz or two-thirds of the 20 dB bandwidth of the hopping channel, whichever is greater, provided the systems operate with an output power no greater than 125 mW.

B.1.2 Results tables

Mode	Packet Type	Channel Number	Frequency [MHz]	20dB BW [MHz]	Freq. Separation [kHz]
Basic Rate GFSK	DH5	0	2402	0.95	1000.0
		39	2441	0.94	
		78	2480	0.94	
EDR $\pi/4$ -DQPSK	2DH5	0	2402	1.36	1002.5
		39	2441	1.36	
		78	2480	1.36	
EDR 8-DPSK	3DH5	0	2402	1.34	1000.0
		39	2441	1.34	
		78	2480	1.34	

Largest value per mode

B.1.3 Results screenshot

Basic Rate - GFSK

20dB BW – CH0

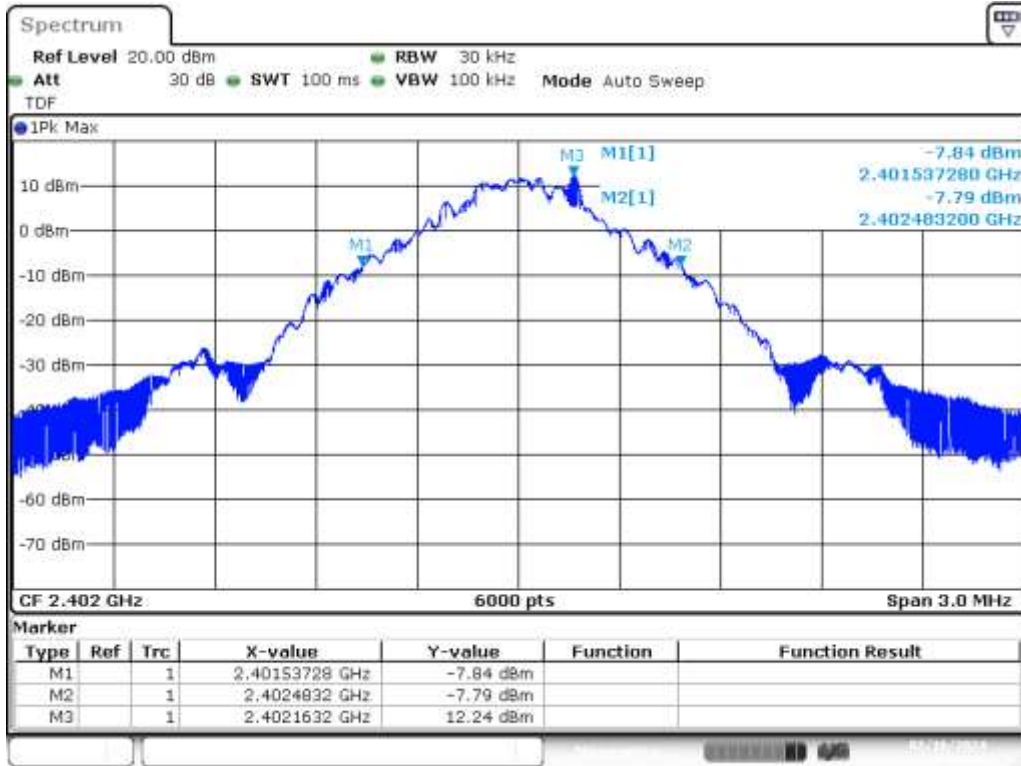

Freq. Separation

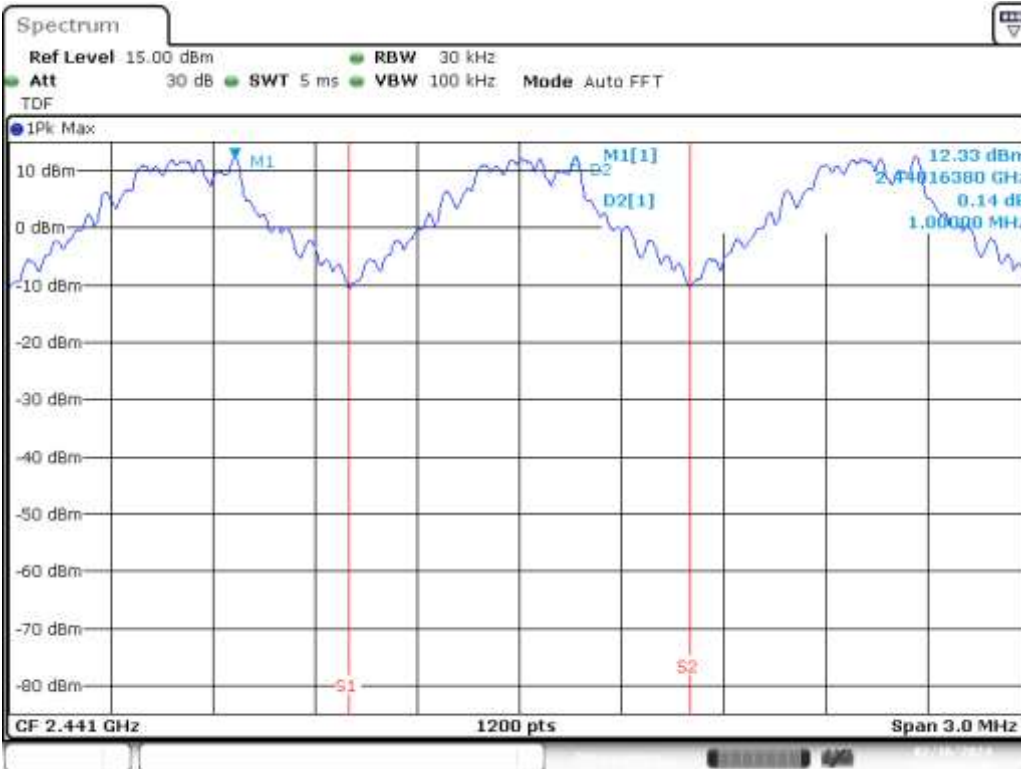

EDR – $\pi/4$ -DQPSK

20dB BW – CH0

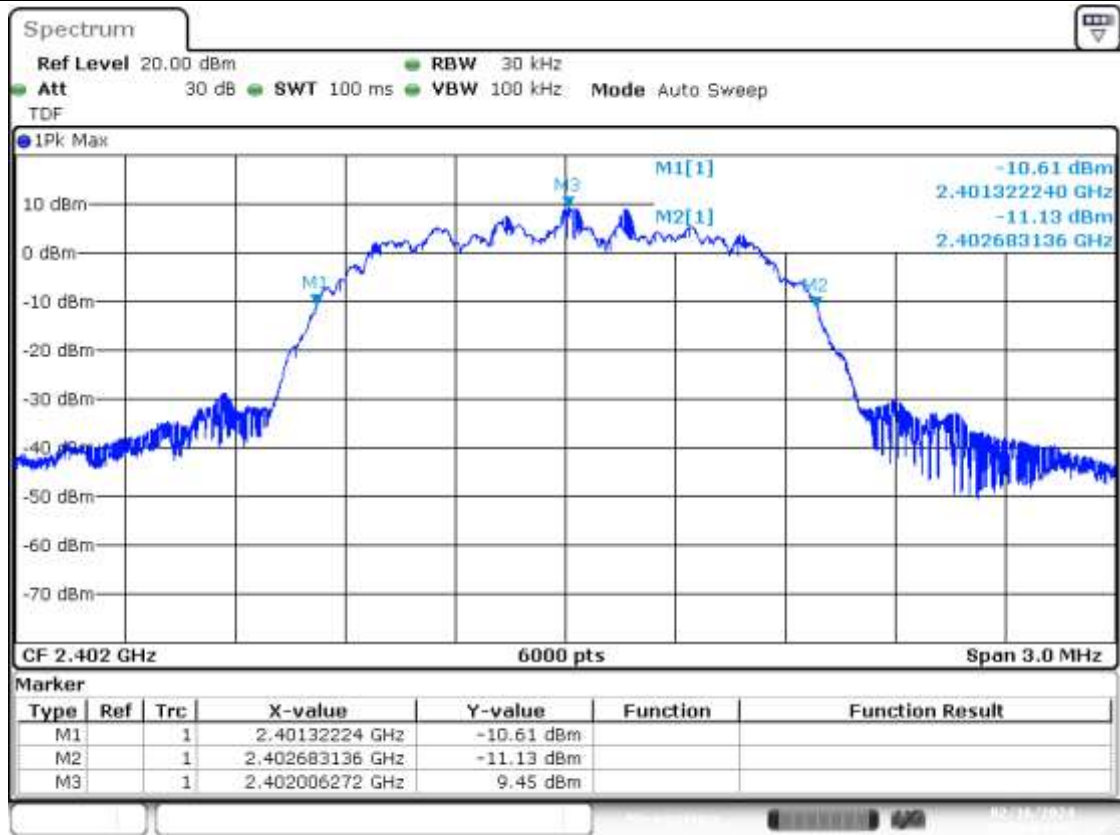

Freq. Separation

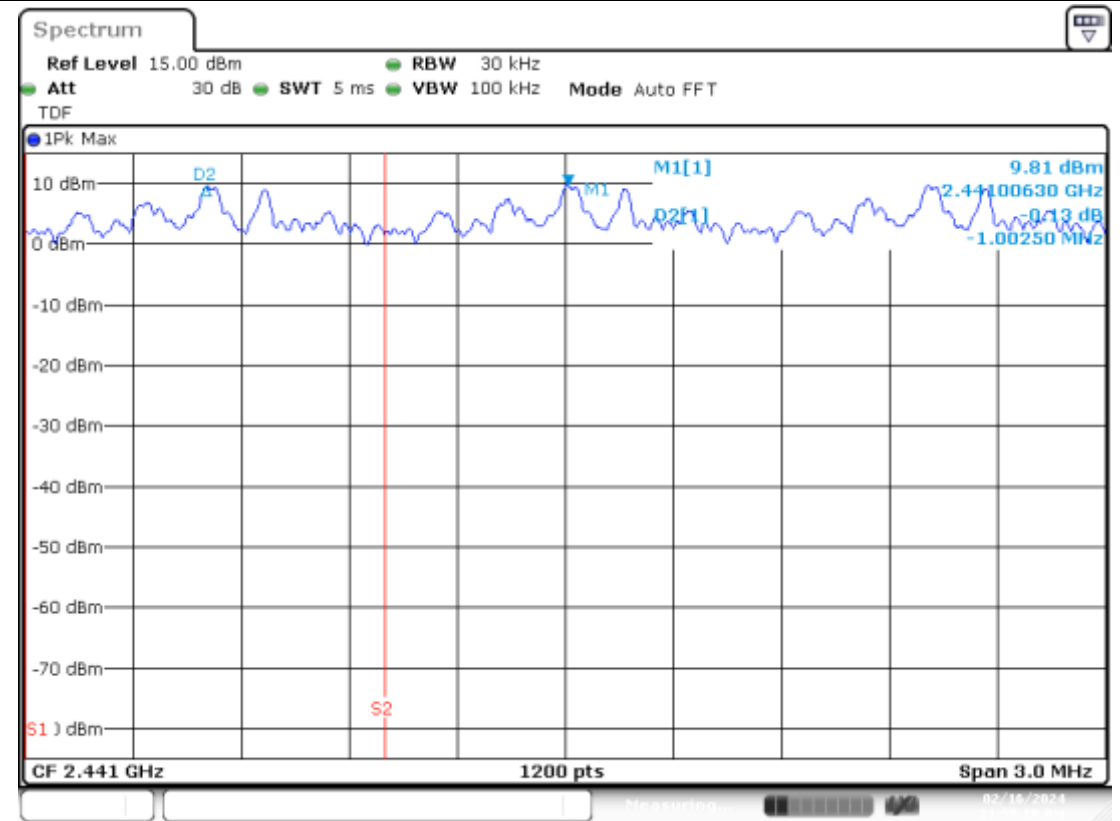

EDR – 8-DPSK

20dB BW – CH0

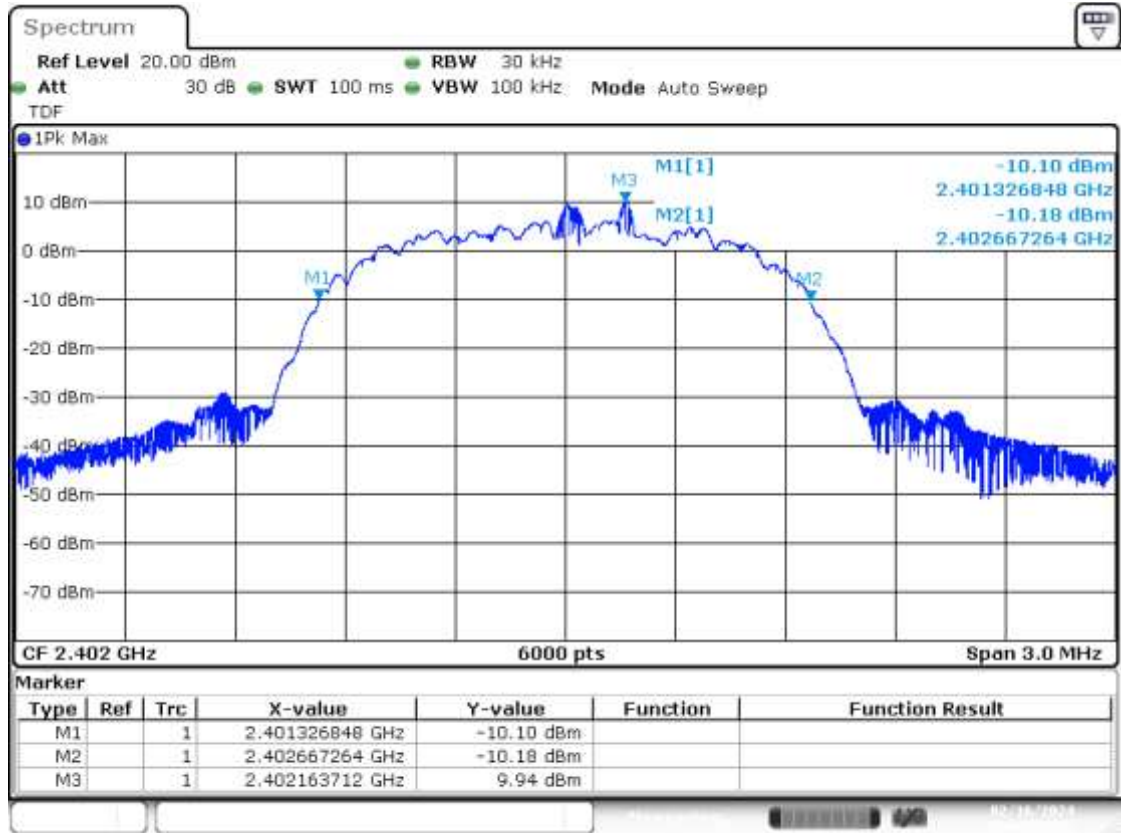

Freq. Separation

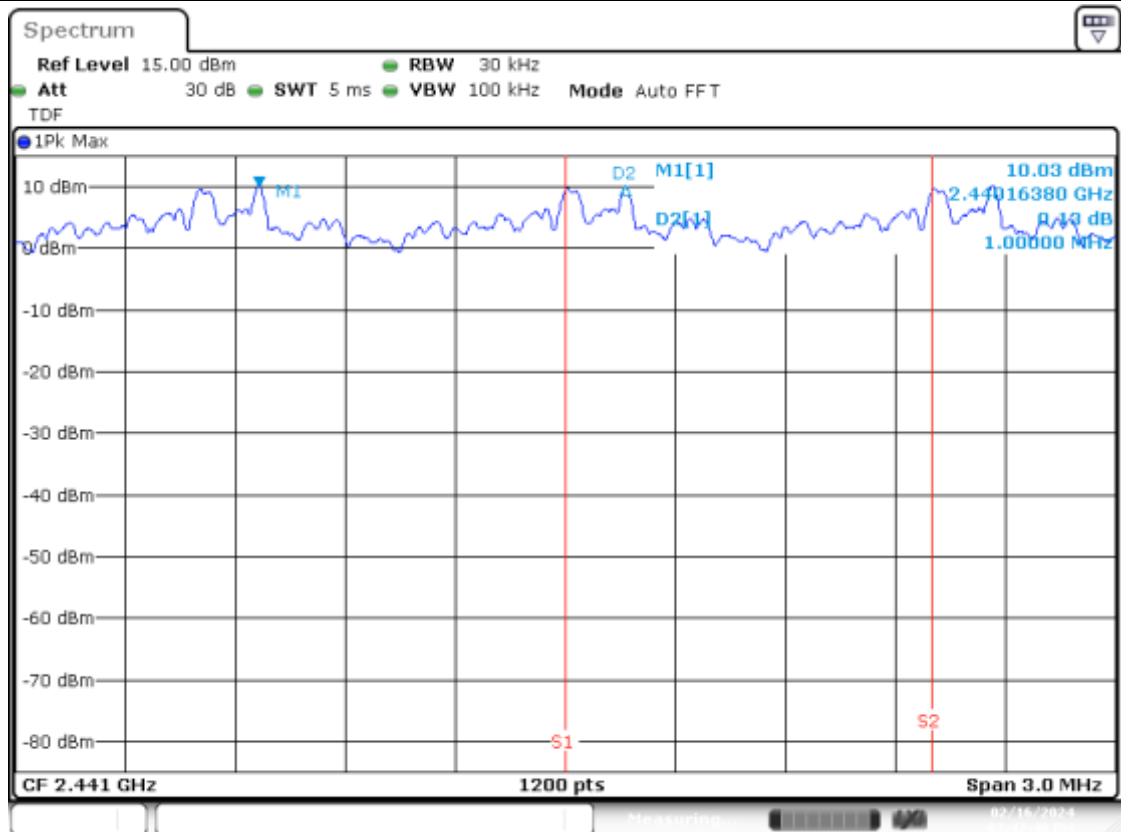

B.2 Number of hopping channels

B.2.1 Test limits

FCC part	RSS part	Limits
15.247 (a) (1) (iii)	RSS-247 Clause 5.1 (d)	Frequency hopping systems in the 2400-2483.5 MHz band shall use at least 15 channels.

B.2.2 Test procedure

The conducted setup shown in section *Test & System Description* was used to measure the number of hopping channels. The antenna terminal of the EUT is connected to the spectrum through an attenuator, and the spectrum analyzer reading is compensated to include the RF path loss.

B.2.3 Results tables

Mode	Packet Type	Number of hopping channels
Basic Rate GFSK	DH5	79
EDR $\pi/4$ -DQPSK	2DH5	79
EDR 8-DPSK	3DH5	79

Number of hopping channels

Basic Rate – GFSK

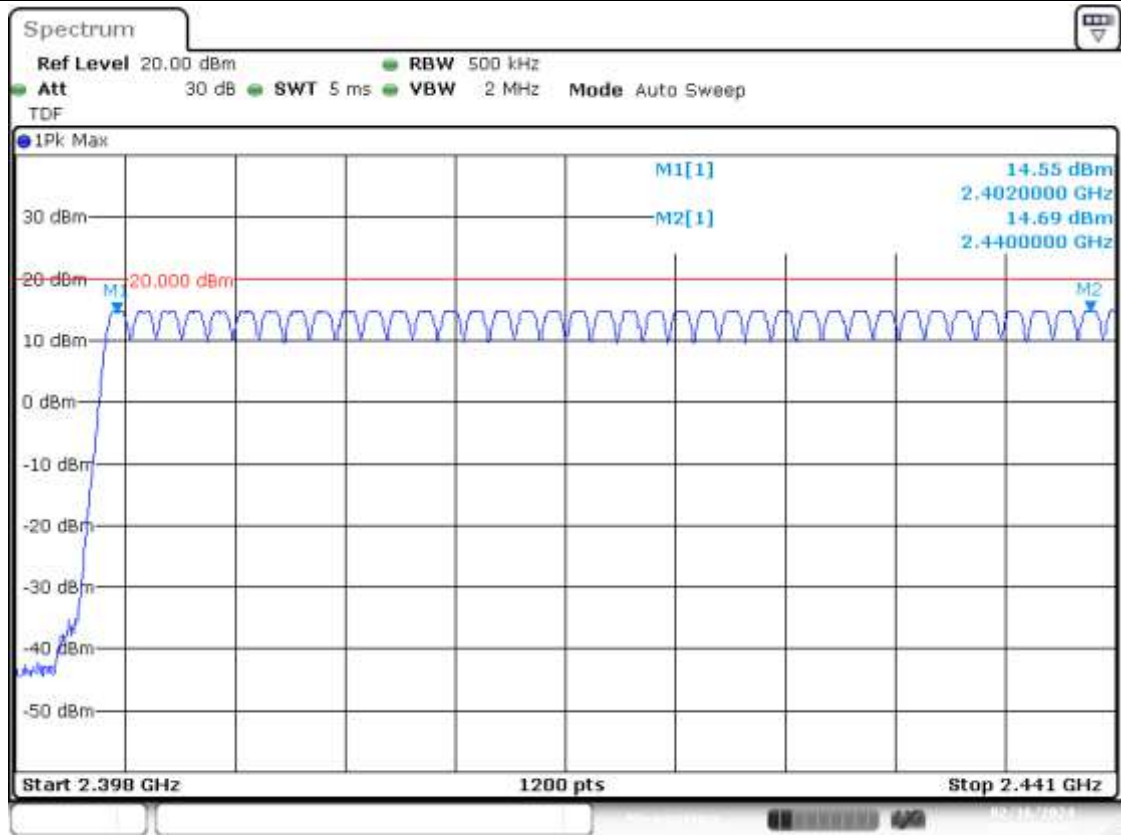

Basic Rate – GFSK

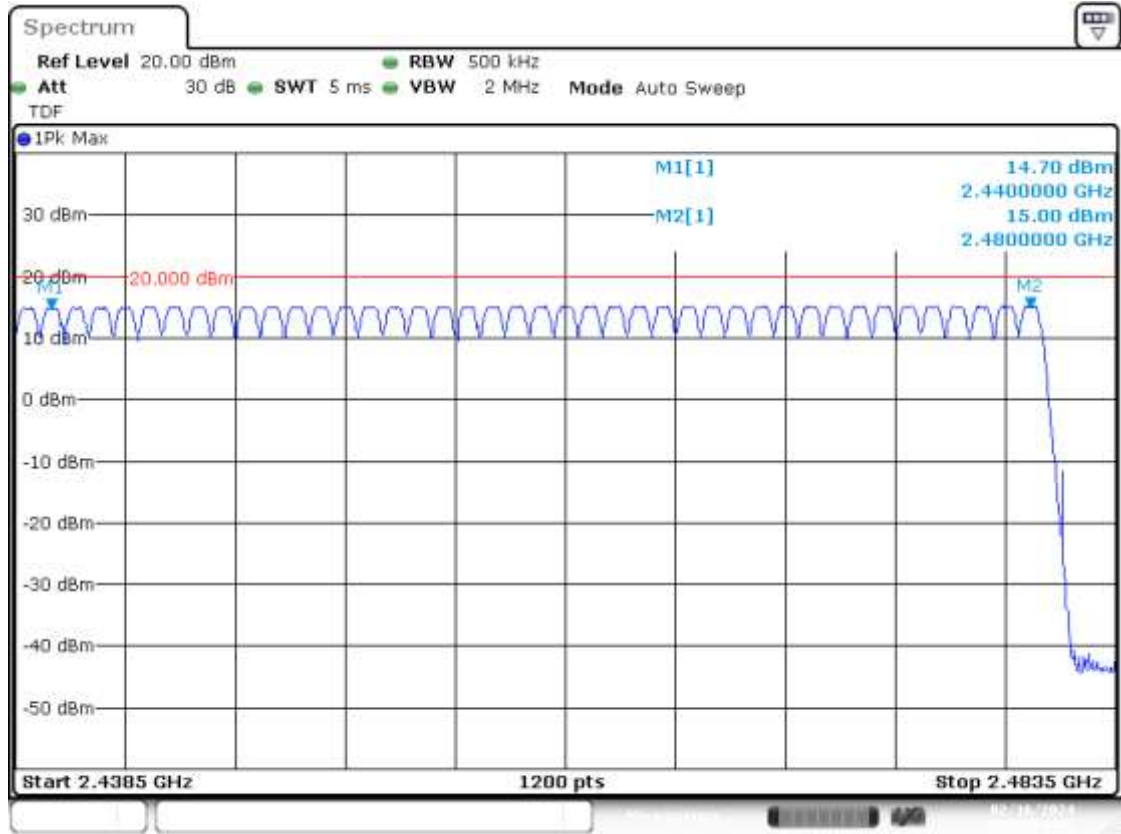

EDR – $\pi/4$ -DPSK

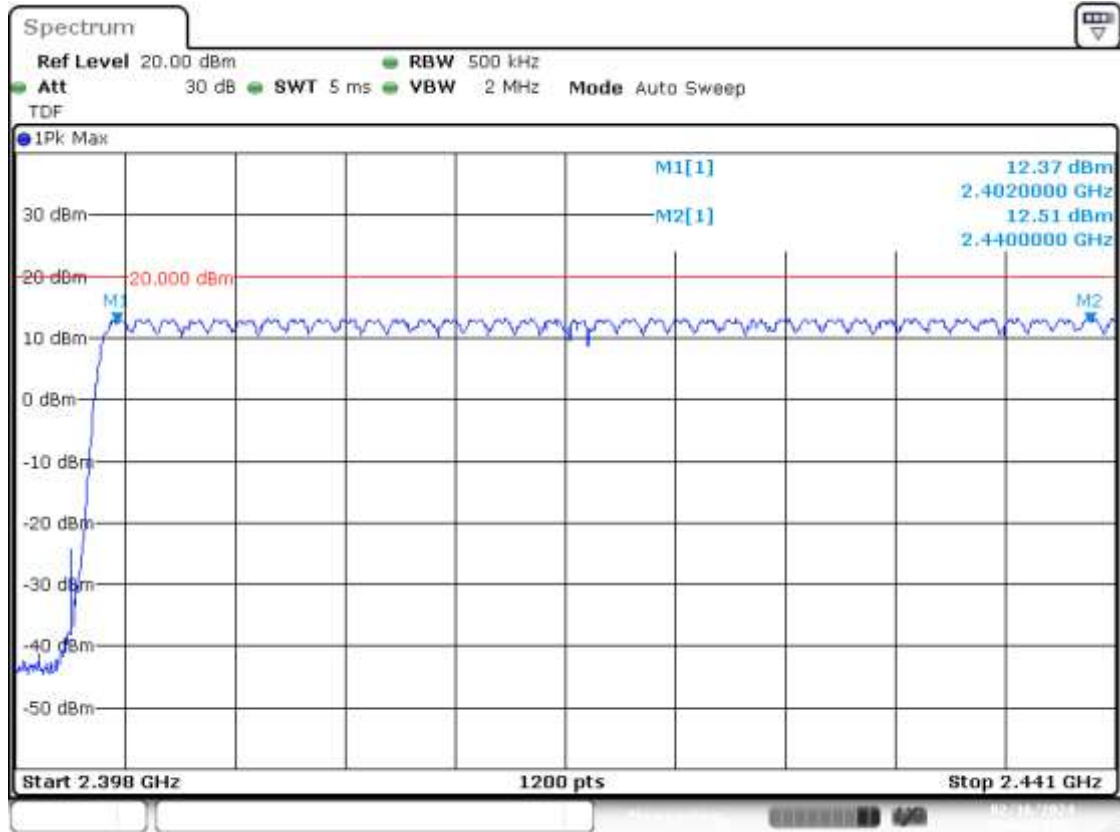

EDR – $\pi/4$ -DPSK

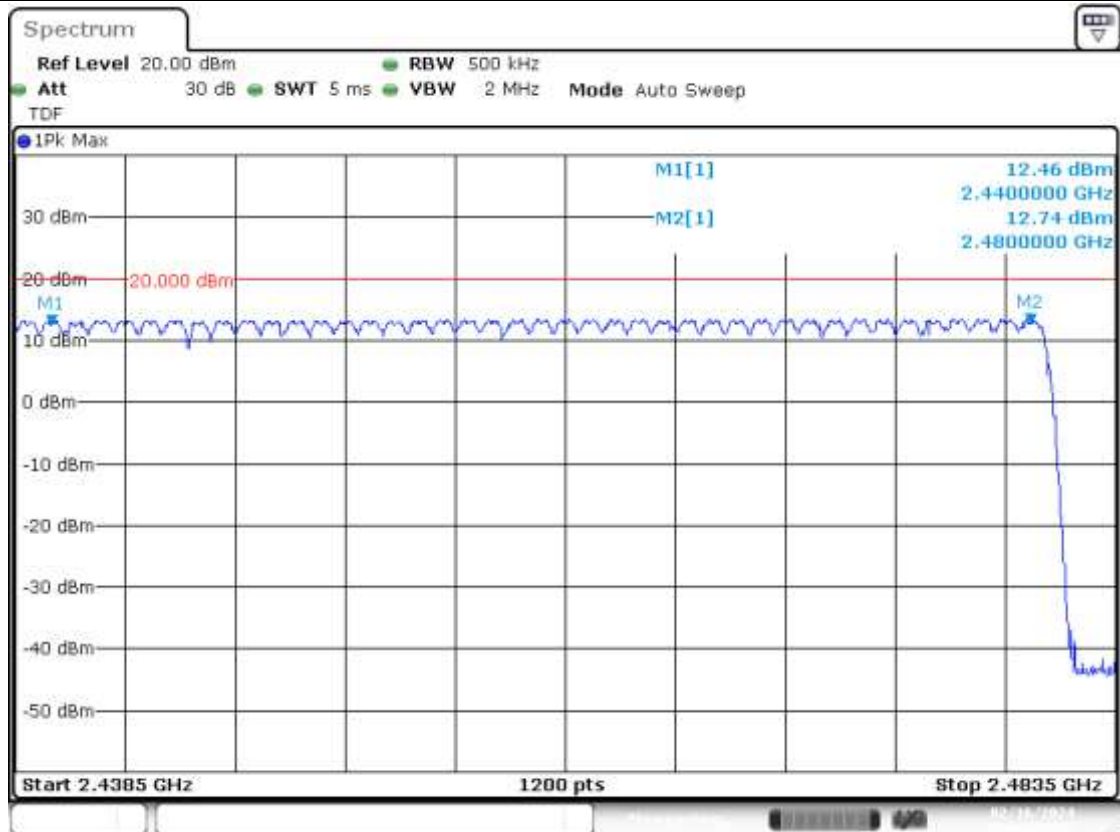

EDR – 8-DPSK

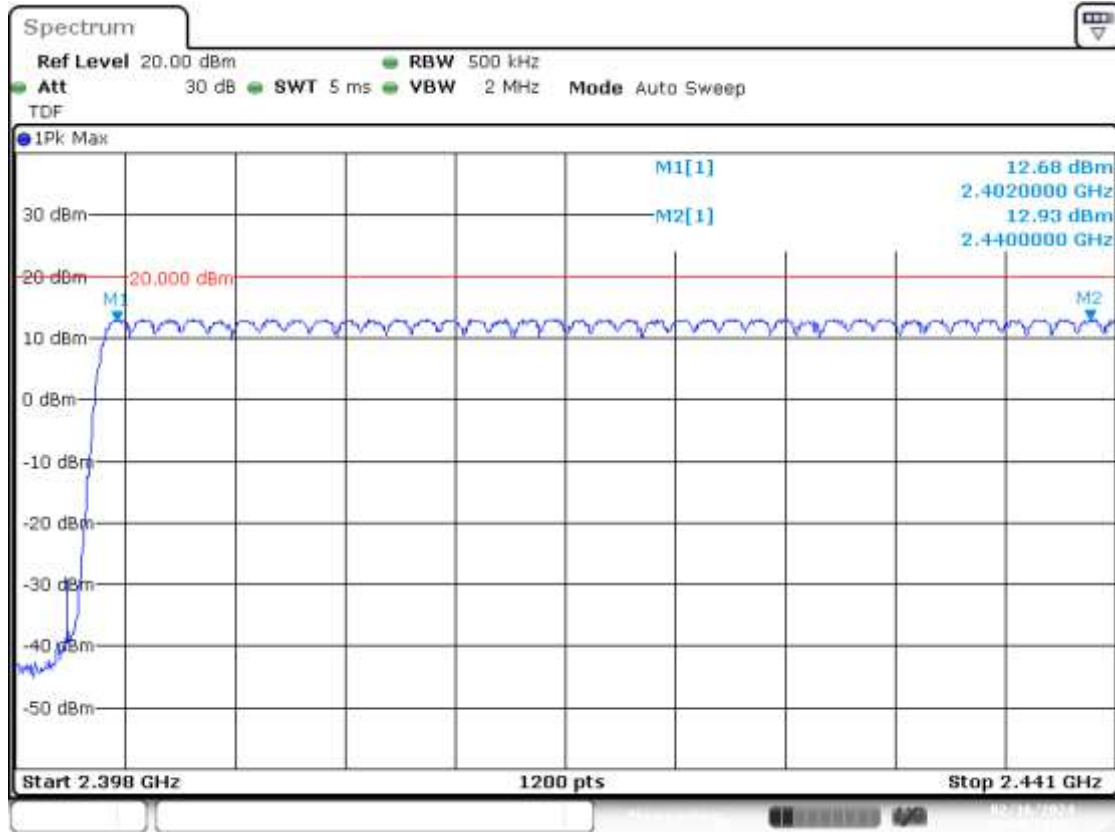

EDR – 8-DPSK

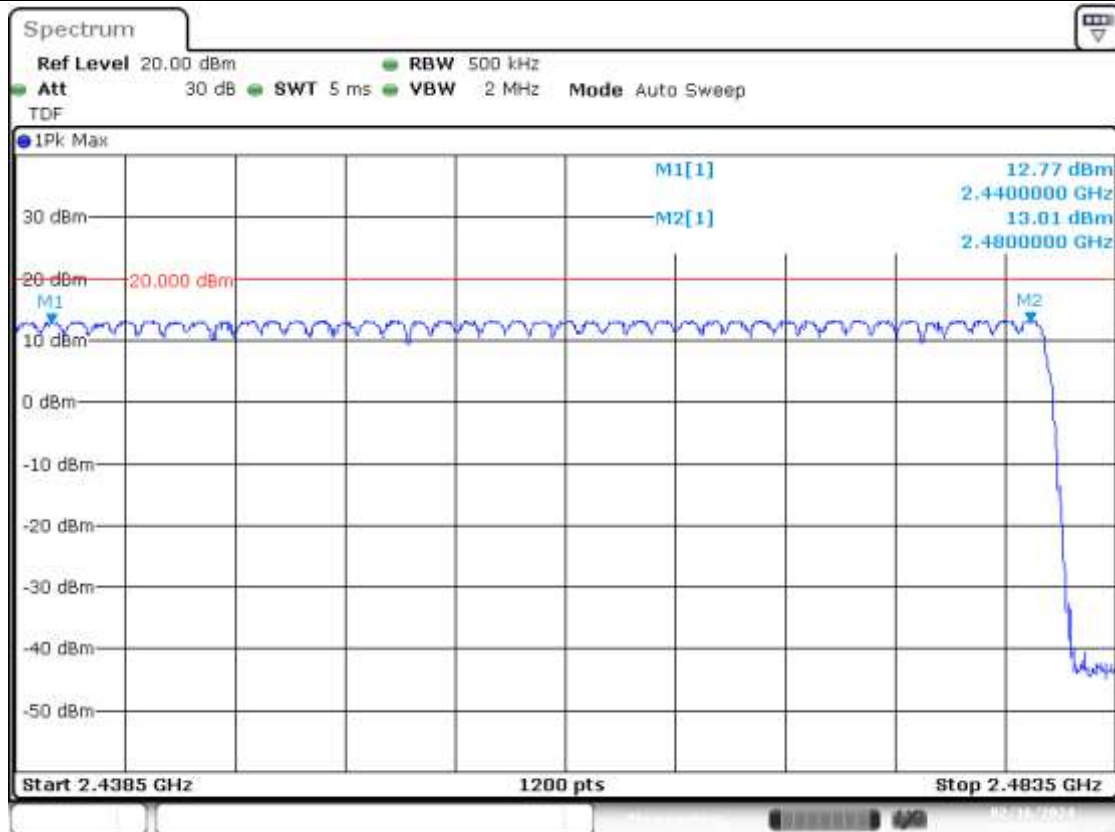

B.3 Time of Occupancy (Dwell Time)

FCC part	RSS part	Limits
15.247 (a) (1) (iii)	RSS-247 Clause 5.1 (d)	The average time of occupancy (Dwell Time) on any channel shall not be greater than 0.4 seconds within a period of 0.4 seconds multiplied by the number of hopping channels employed.

B.3.1 Test procedure

The conducted setup shown in section *Test & System Description* was used to measure the dwell time. The antenna terminal of the EUT is connected to the spectrum through an attenuator, and the spectrum analyzer reading is compensated to include the RF path loss.

In the worst case, the system makes 1600 hops per second with 79 channels, providing a 1 timeslot length of 625 μ s.

A DH1 packet, with independence of the modulation, needs 1 time slot for transmitting and 1 time slot for receiving. Then, the system makes in the worst case $1600/2 = 800$ hops per second with 79 channels. So each channel appears $800/79 = 10.13$ times per second and, for a period of $0.4 \times 79 = 31.6$ seconds, each channel appears $10.13 \times 31.6 = 320.11$ times.

A DH3 packet, with independence of the modulation, needs 3 time slots for transmitting and 1 time slot for receiving. Then, the system makes in the worst case $1600/4 = 400$ hops per second with 79 channels. So each channel appears $400/79 = 5.1$ times per second and, for a period of $0.4 \times 79 = 31.6$ seconds, each channel appears $5.1 \times 31.6 = 161.16$ times.

A DH5 packet, with independence of the modulation, needs 5 time slots for transmitting and 1 time slot for receiving. Then, the system makes in the worst case $1600/6 = 266.67$ hops per second with 79 channels. So each channel appears $266.67/79 = 3.37$ times per second and, for a period of $0.4 \times 79 = 31.6$ seconds, each channel appears $3.37 \times 31.6 = 106.49$ times.

Thus, the total time of occupancy is obtained by multiplying the calculated maximum number of appearances per packet type and the measured Tx-time, as shown in the results screenshots.

B.3.2 Results tables

Mode	Packet Type	Times of appearance	Tx-time [ms]	Dwell Time [ms]
Basic Rate GFSK	DH1	320.11	0.372	119.00
	DH3	161.16	1.626	261.98
	DH5	106.49	2.880	306.71
EDR $\pi/4$ -DQPSK	2-DH1	320.11	0.380	121.67
	2-DH3	161.16	1.634	263.32
	2-DH5	106.49	2.880	306.71
EDR 8-DPSK	3-DH1	320.11	0.376	120.34
	3-DH3	161.16	1.630	262.65
	3-DH5	106.49	2.884	307.16

B.3.3 Results Screenshot

BDR – GFSK

DH1 Tx-Time

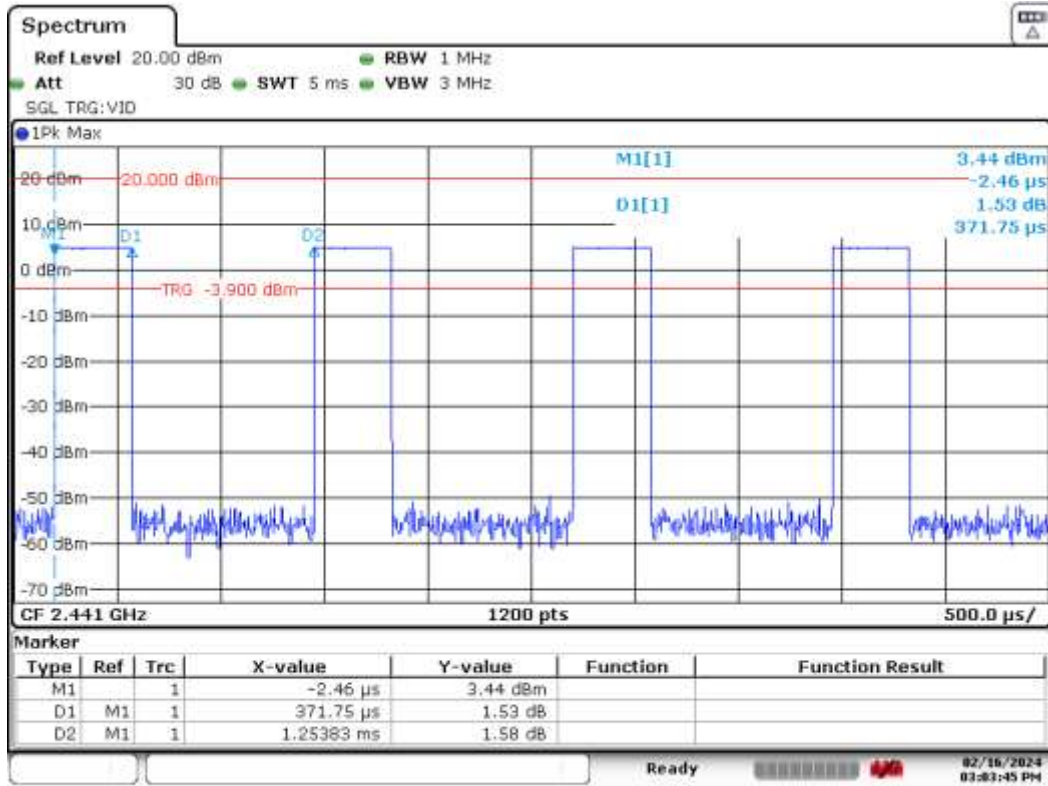

Date: 16.FEB.2024 15:03:45

DH3 Tx-Time

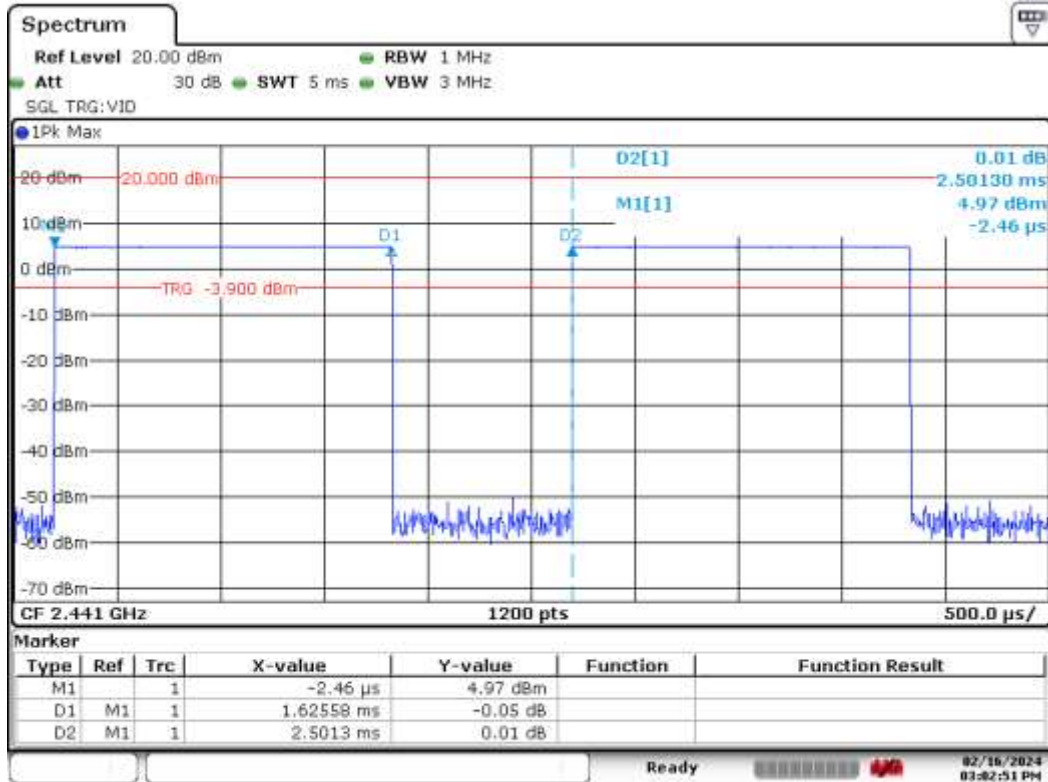

Date: 16.FEB.2024 15:02:51

DH5 Tx-Time

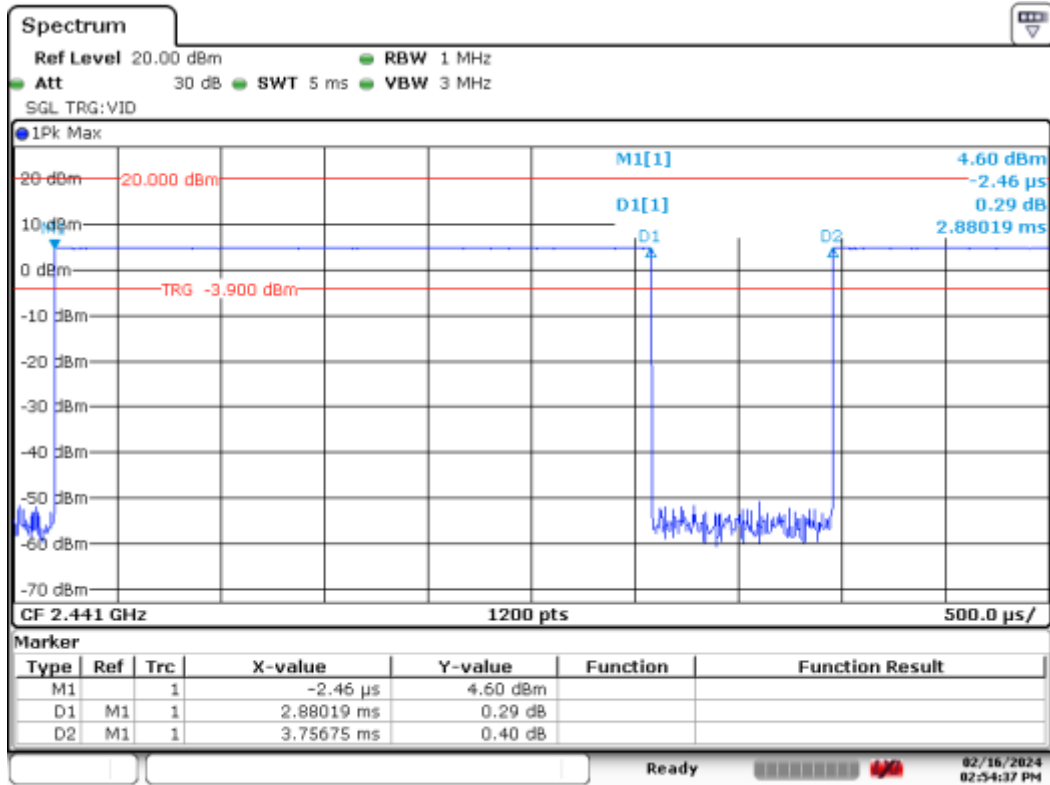

Date: 16.FEB.2024 14:54:37

EDR - $\pi/4$ -DQPSK

2-DH1 Tx-Time

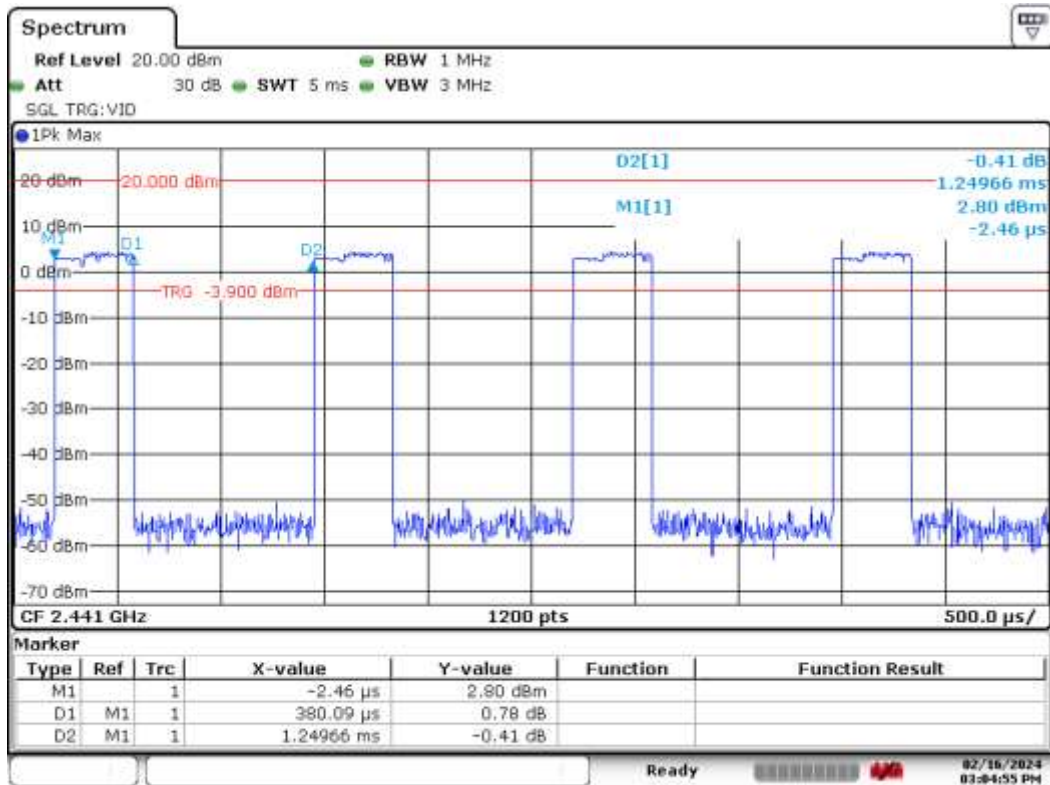

Date: 16.FEB.2024 15:04:55

2-DH3 Tx-Time

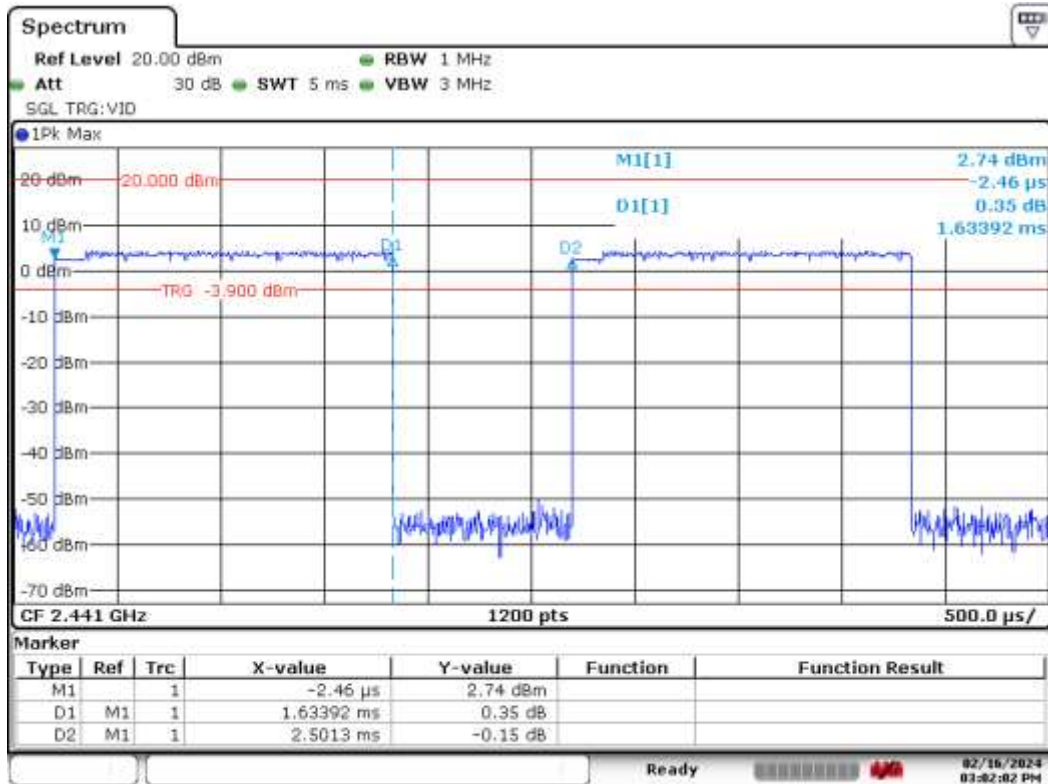

Date: 16.FEB.2024 15:02:02

2-DH5 Tx-Time

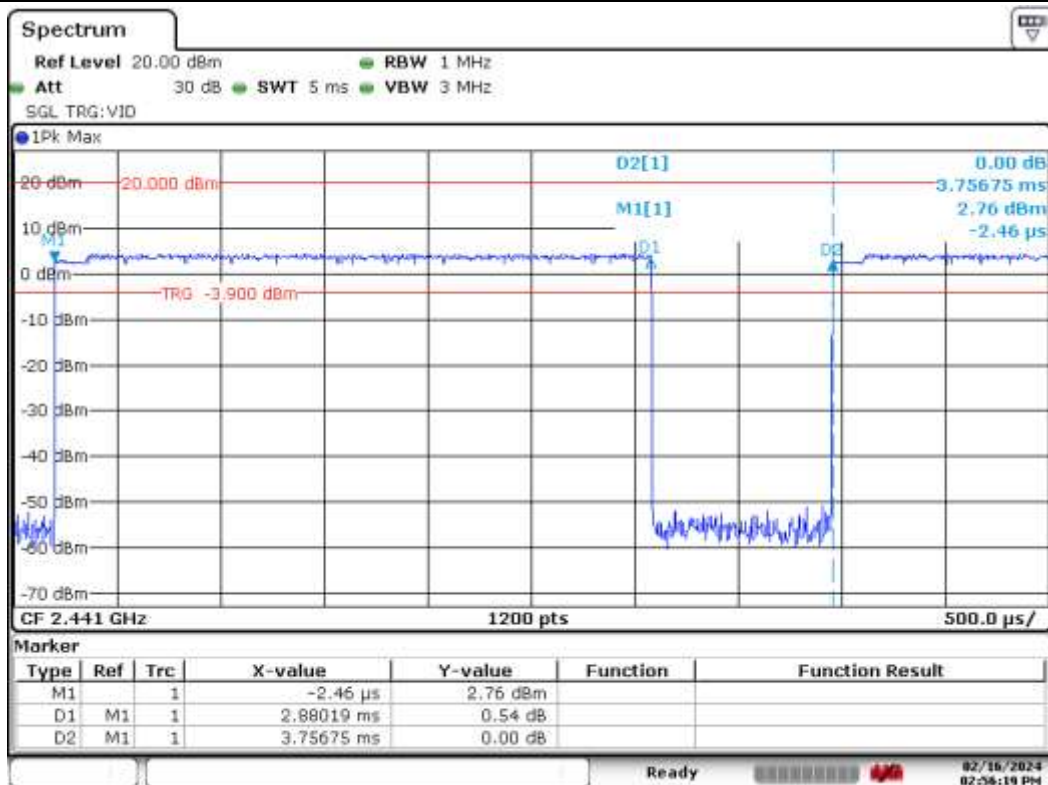

Date: 16.FEB.2024 14:56:19

EDR – 8-DPSK

3-DH1 Tx-Time

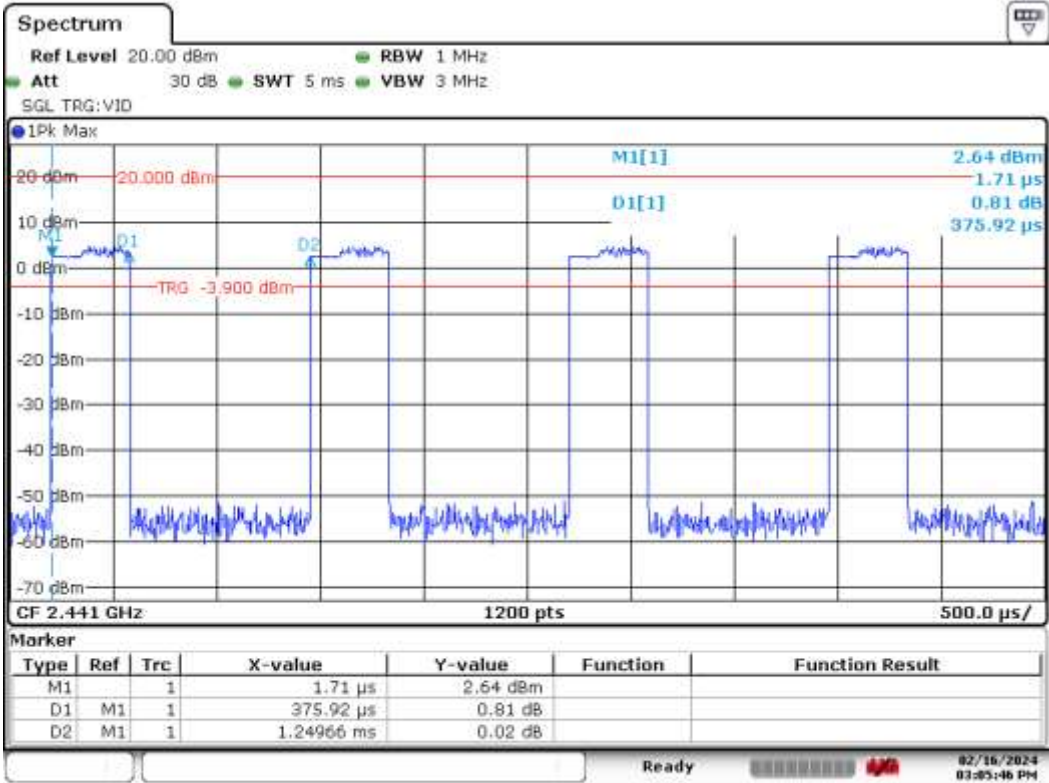

Date: 16.FEB,2024 15:05:47

3-DH3 Tx-Time

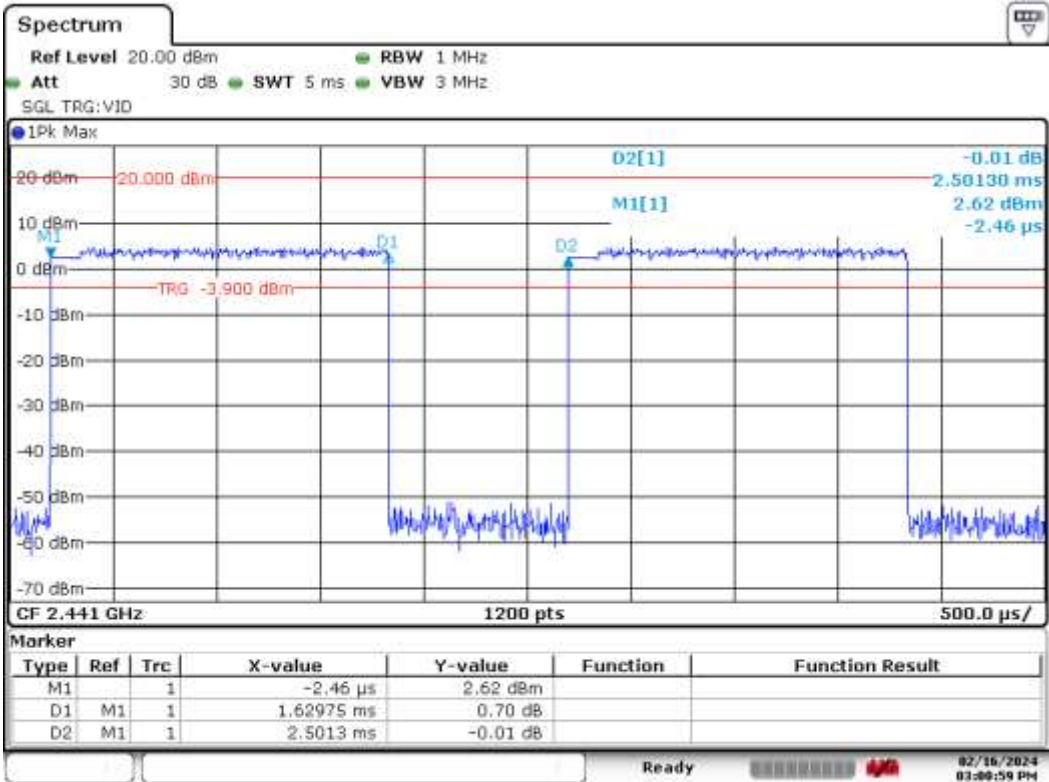

Date: 16.FEB,2024 15:00:59

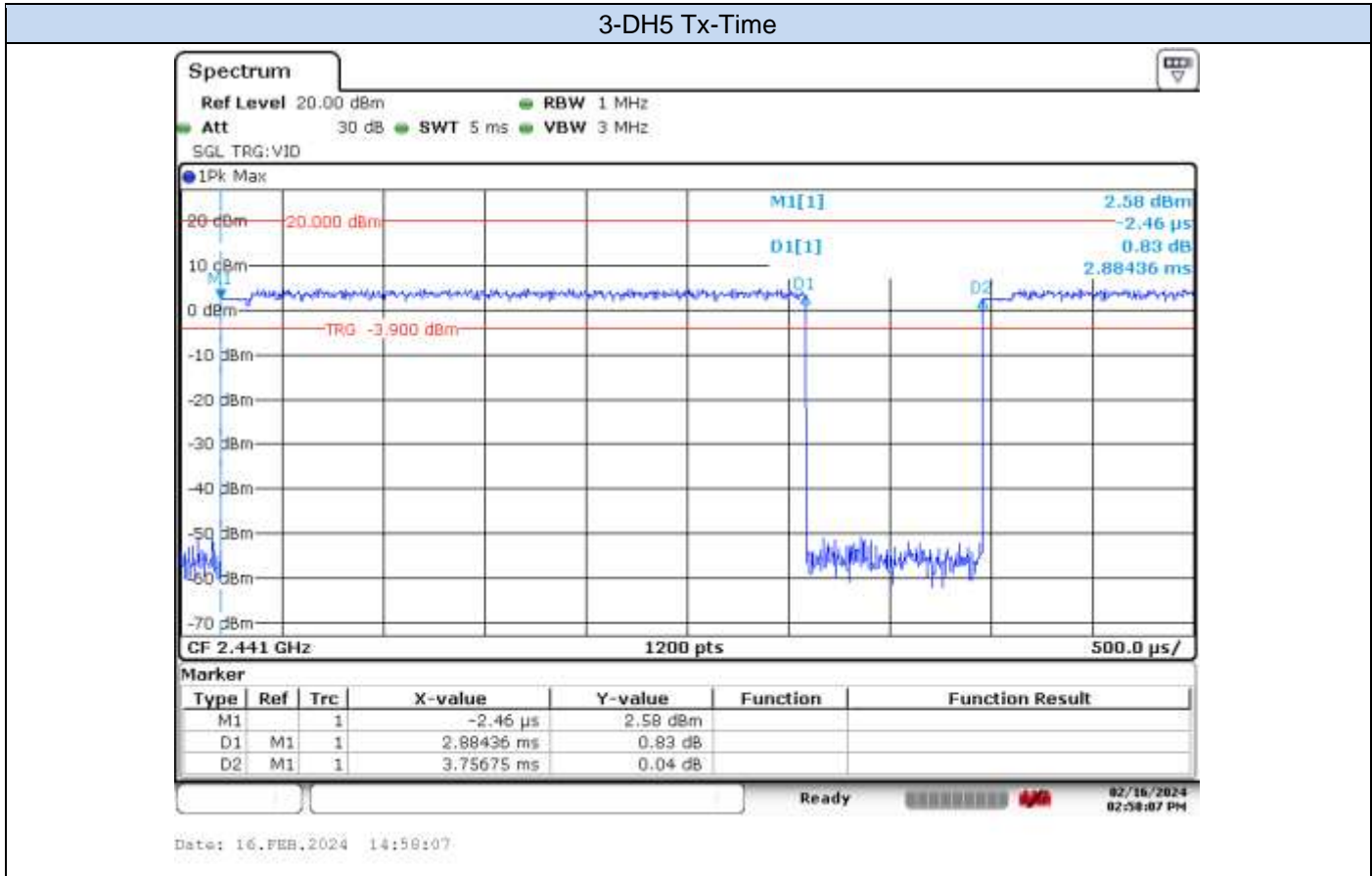

B.4 Maximum Peak Output Power antenna gain

B.4.1 Test Limits

FCC part	RSS part	Limits
15.247 (b) (1)	RSS-247 Clause 5.4 (b)	<p>(b) The maximum peak conducted output power of the intentional radiator shall not exceed the following:</p> <p>(1) For frequency hopping systems operating in the 2400-2483.5 MHz band employing at least 75 non-overlapping hopping channels, and all frequency hopping systems in the 5725-5850 MHz band: 1 watt. (...)</p> <p>(4) The conducted output power limit specified in paragraph (b) of this section is based on the use of antennas with directional gains that do not exceed 6 dBi.</p>

B.4.2 Test procedure

The conducted setup shown in section *Test & System Description* was used to measure the maximum peak output power. The antenna terminal of the EUT is connected to the spectrum through an attenuator, and the spectrum analyzer reading is compensated to include the RF path loss.

B.4.3 Results tables

Mode	Packet Type	Channel Number	Frequency [MHz]	Peak Power [dBm]	Peak Power [mW]	Peak Power EIRP [dBm]	Peak Power EIRP [mW]
Basic Rate GFSK	DH5	0	2402	14.76	29.92	17.76	59.70
		39	2441	14.96	31.33	17.96	62.52
		78	2480	15.15	32.73	18.15	65.31
EDR $\pi/4$ -DQPSK	2DH5	0	2402	14.46	27.93	17.46	55.72
		39	2441	14.66	29.24	17.66	58.34
		78	2480	14.86	30.62	17.86	61.09
EDR 8-DPSK	3DH5	0	2402	14.78	30.06	17.78	59.98
		39	2441	14.95	31.26	17.95	62.37
		78	2480	15.16	32.81	18.16	65.46

Highest/Lowest power per mode

B.4.4 Results Screenshot

Basic Rate - GFSK

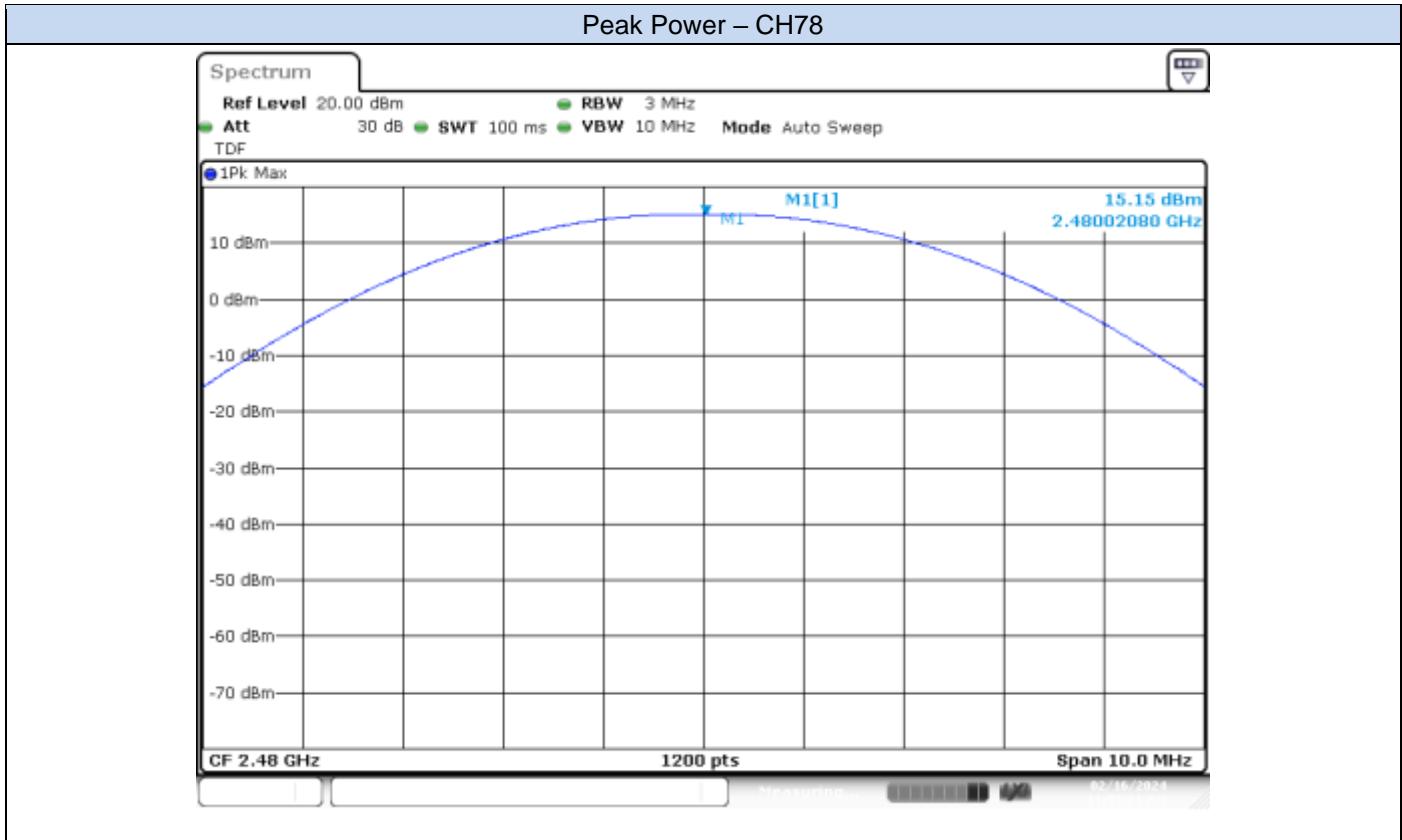

EDR – $\pi/4$ -DQPSK

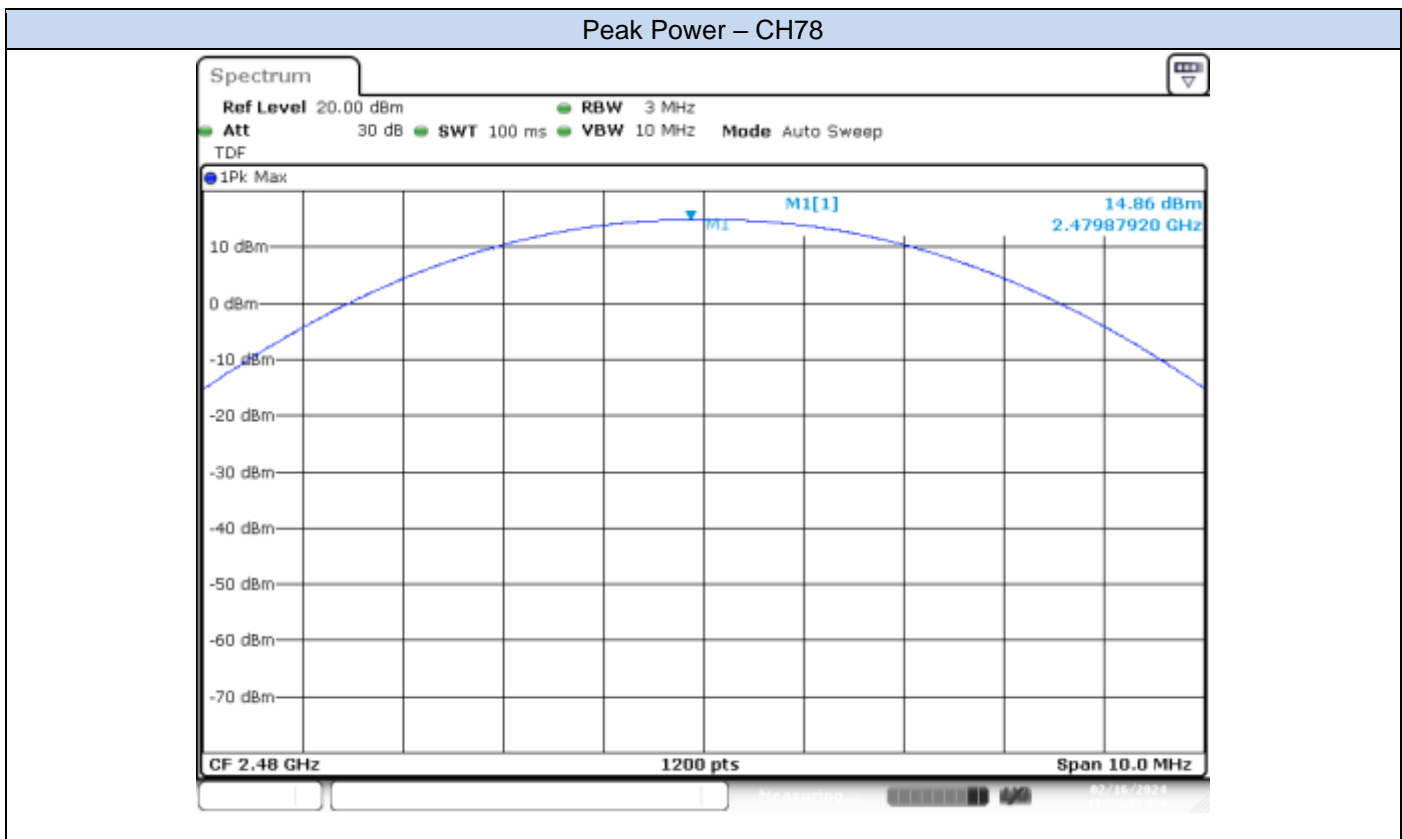

EDR – 8-DPSK

Peak Power – CH78

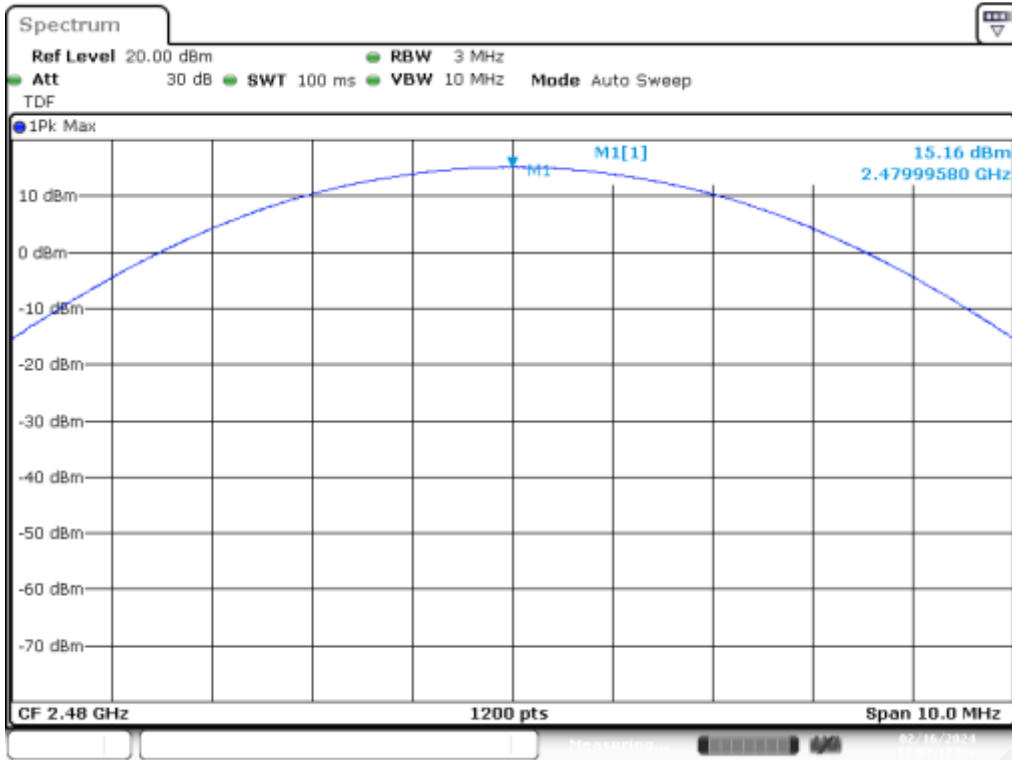

B.5 Out-of-band emission (conducted)

B.5.1 Test limits

FCC part	RSS part	Limits
15.247 (d)	RSS-247 Clause 5.5	In any 100 kHz bandwidth outside the frequency band in which the spread spectrum or digitally modulated intentional radiator is operating, the radio frequency power that is produced by the intentional radiator shall be at least 20 dB below that in the 100 kHz bandwidth within the band that contains the highest level of the desired power, based on either an RF conducted or a radiated measurement, provided the transmitter demonstrates compliance with the peak conducted power limits.

B.5.2 Test procedure

The conducted setup shown in section *Test & System Description* was used to measure the out-of-band emissions (conducted). The antenna terminal of the EUT is connected to the spectrum through an attenuator, and the spectrum analyzer reading is compensated to include the RF path loss.

B.5.3 Test results

Basic Rate - GFSK

BE NR Low Freq Section – CH0

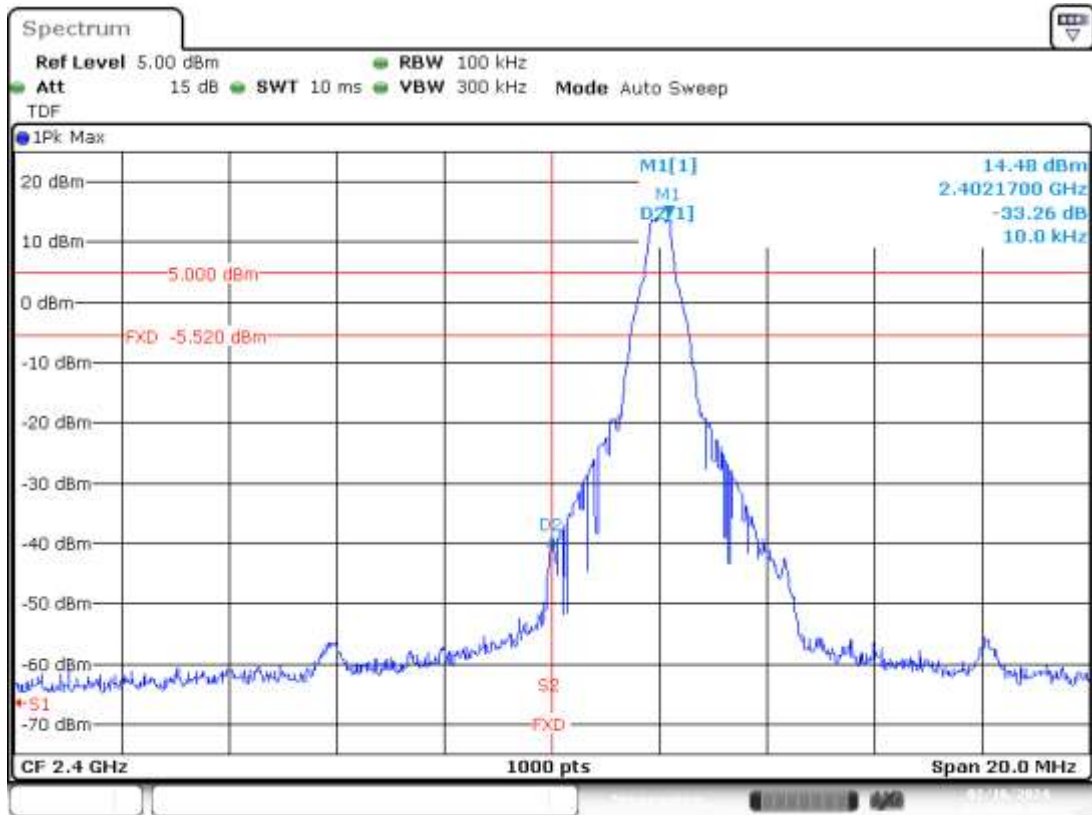

BE R Low Freq Section – CH0

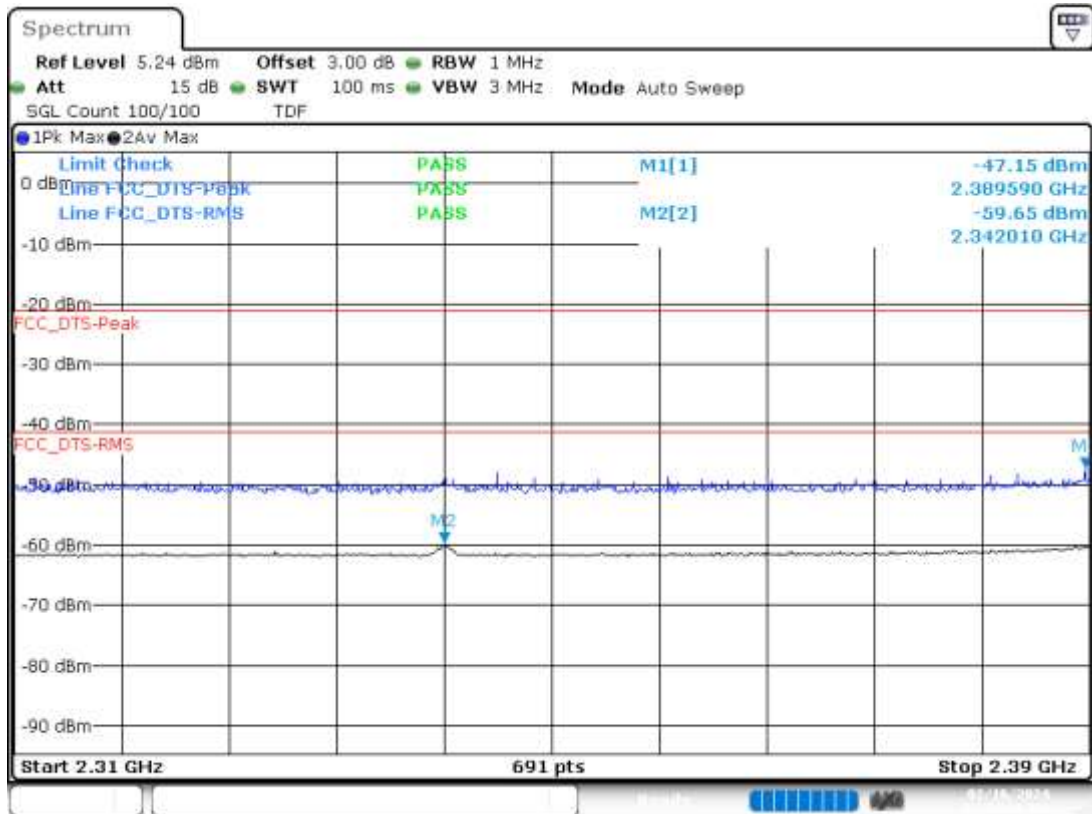

BE R High Freq Section – CH78

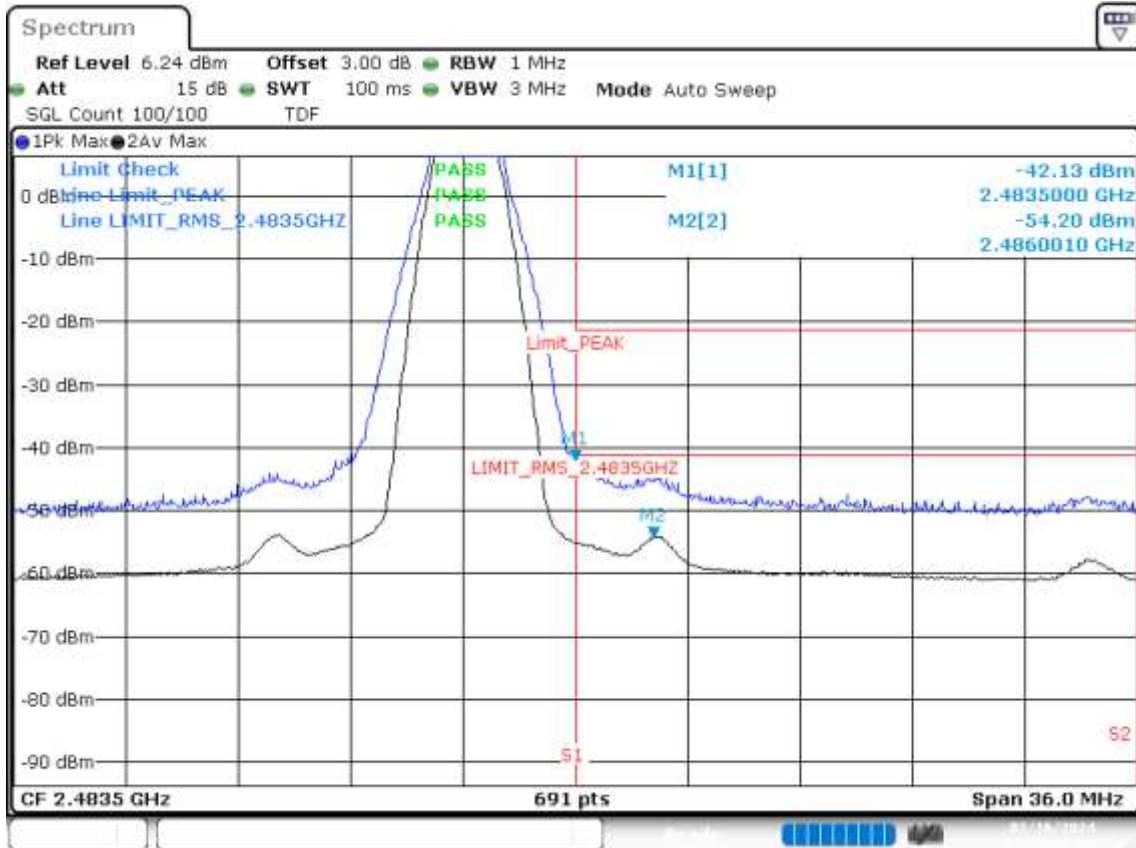

BE R Low Freq Section – Hopping

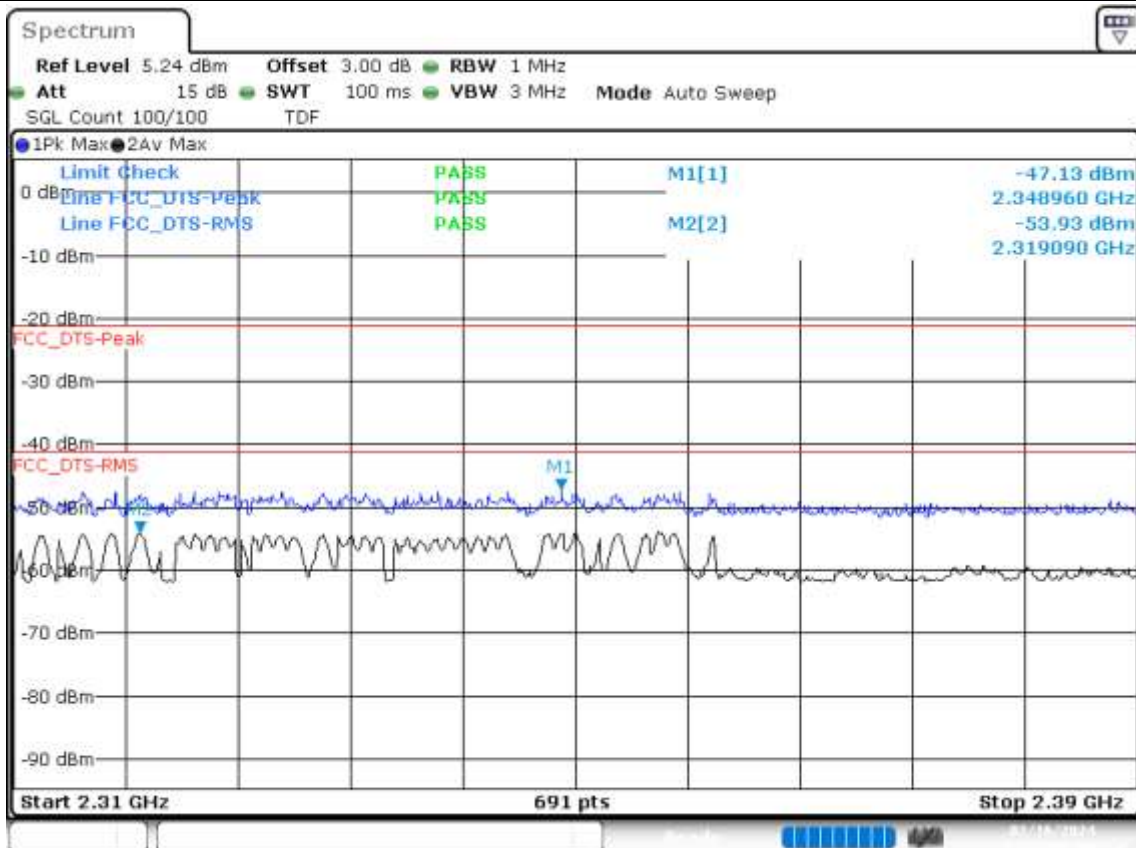

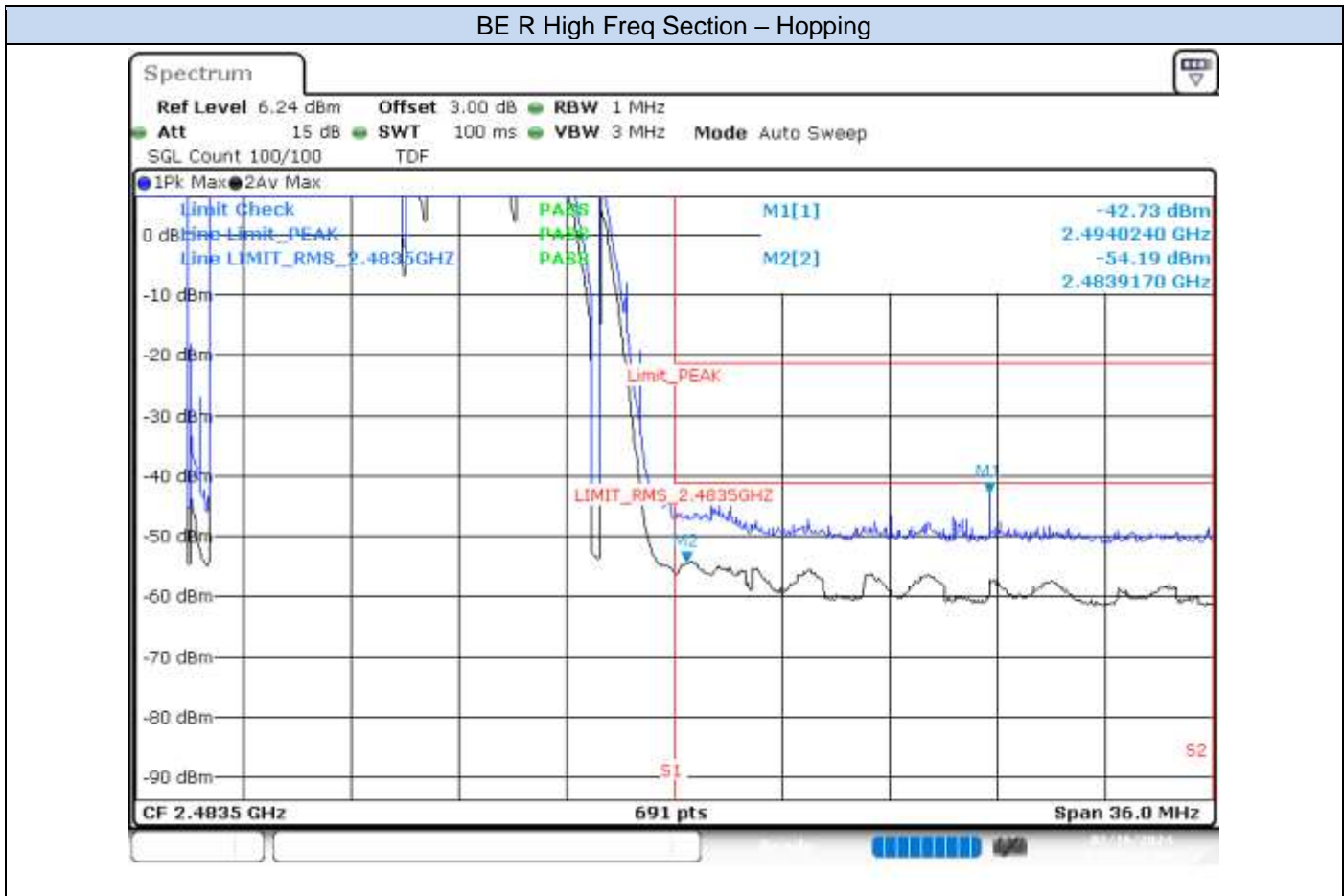

EDR – $\pi/4$ -DQPSK

BE NR Low Freq Section – CH0

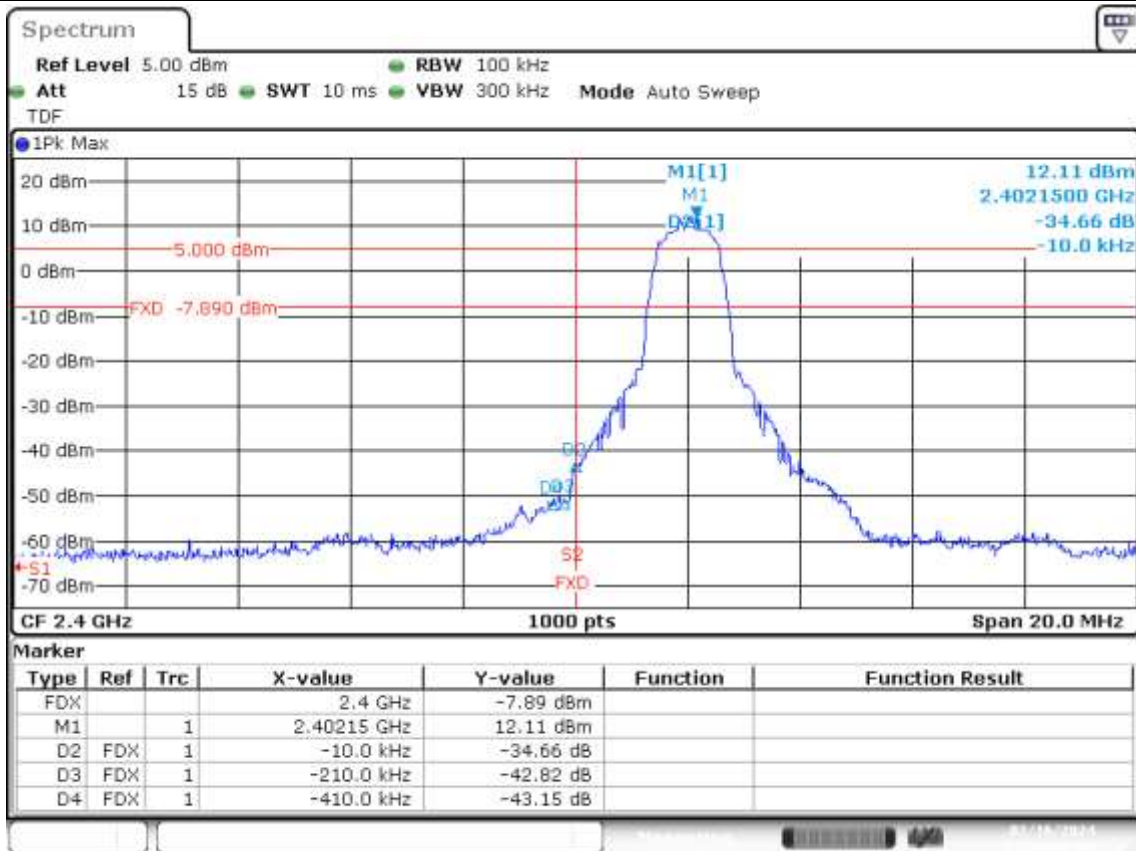

BE R Low Freq Section – CH0

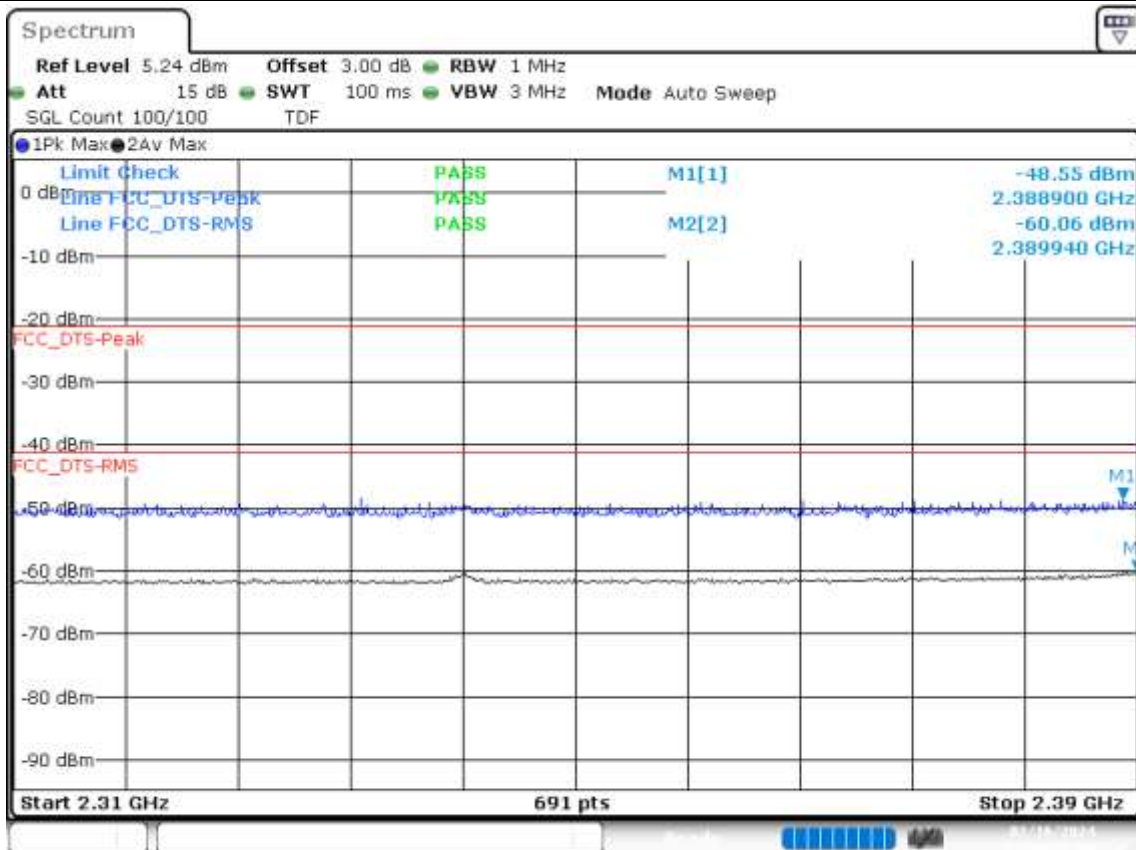

BE R High Freq Section – CH78

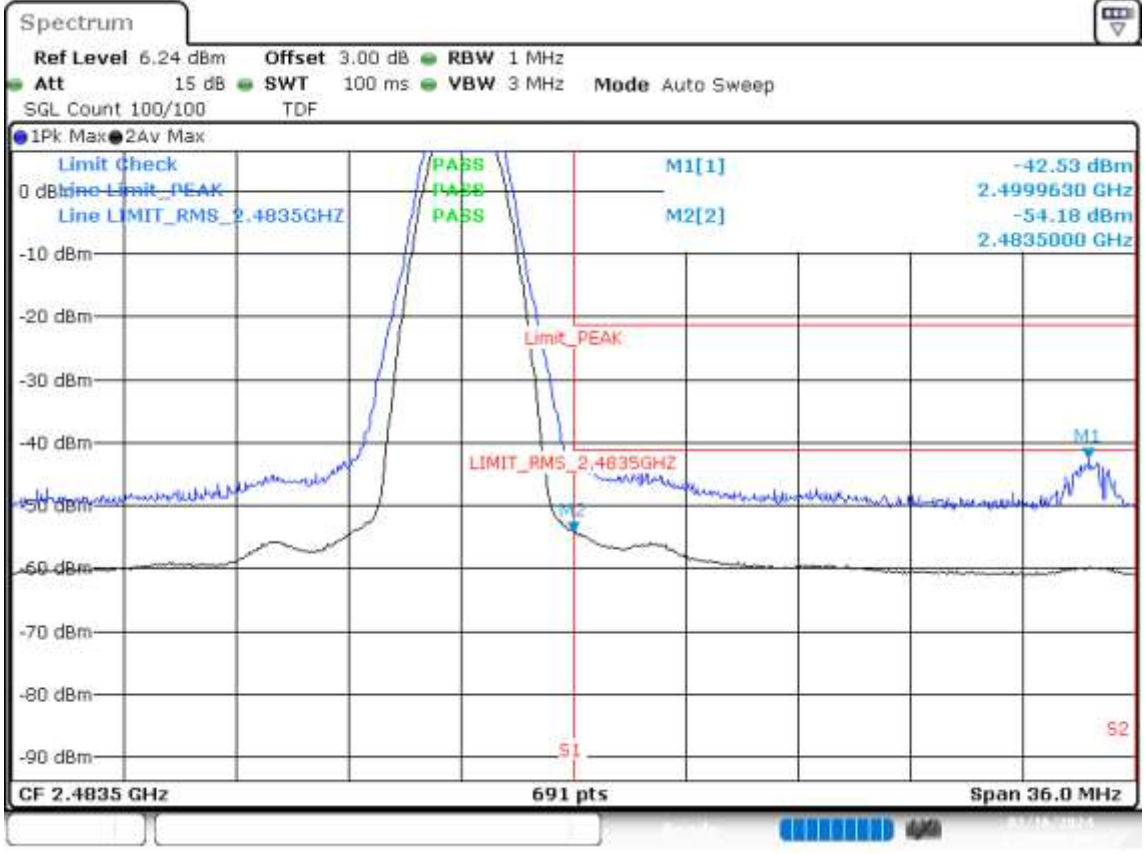

BE R Low Freq Section – Hopping

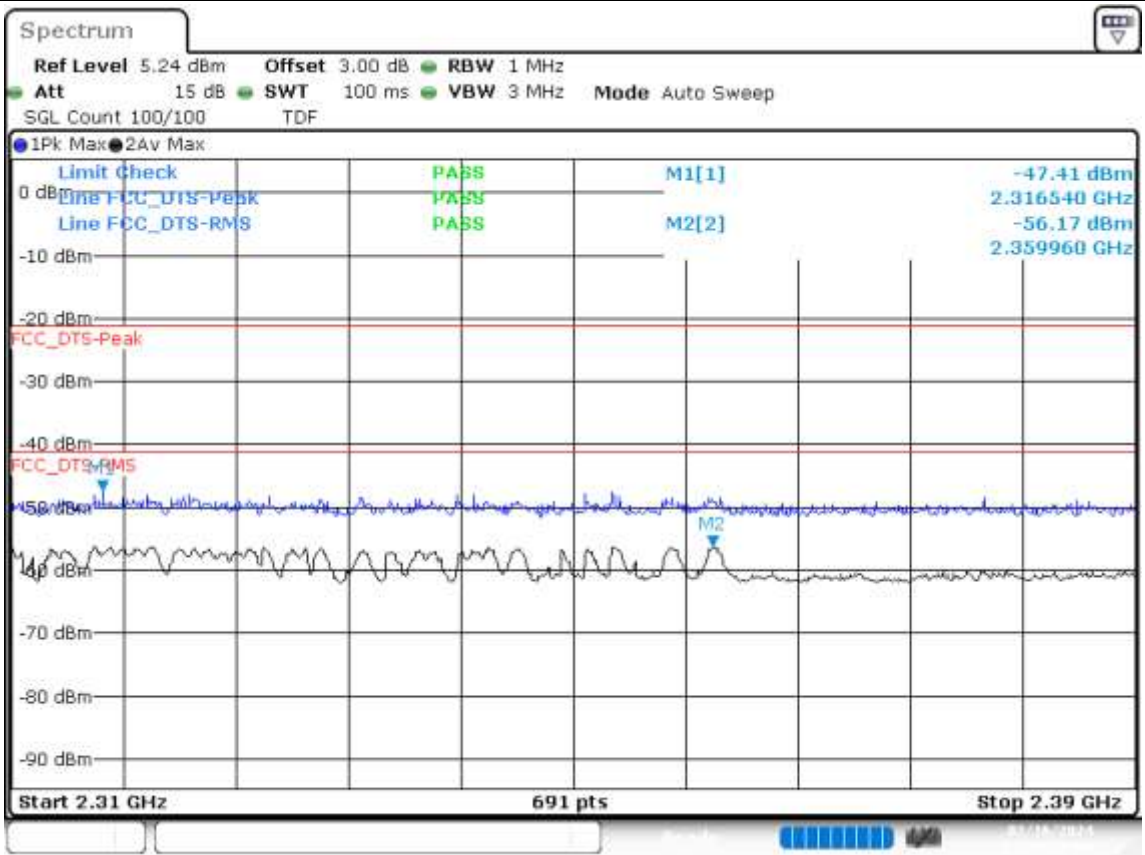

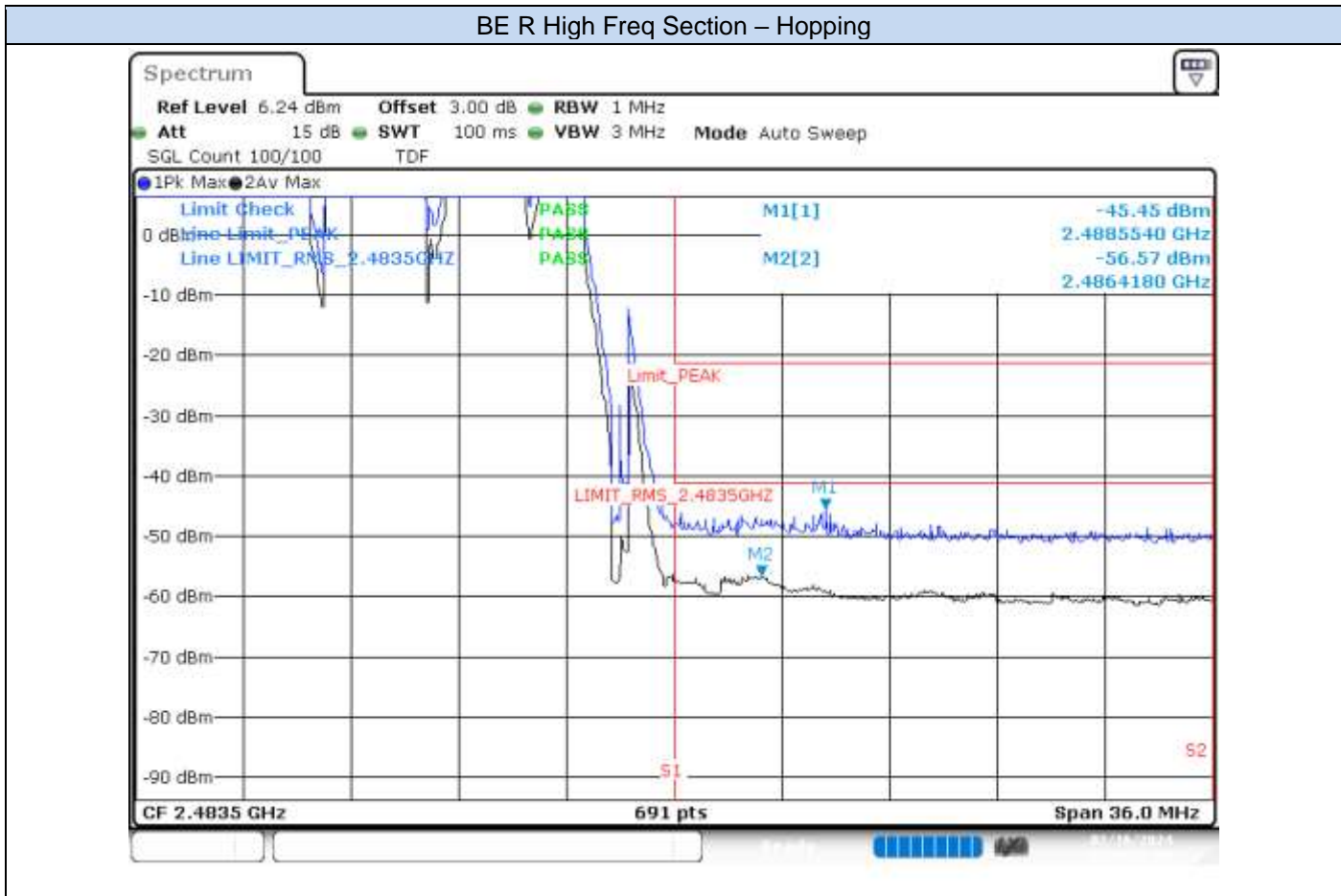

EDR – 8-DPSK

BE NR Low Freq Section – CH0

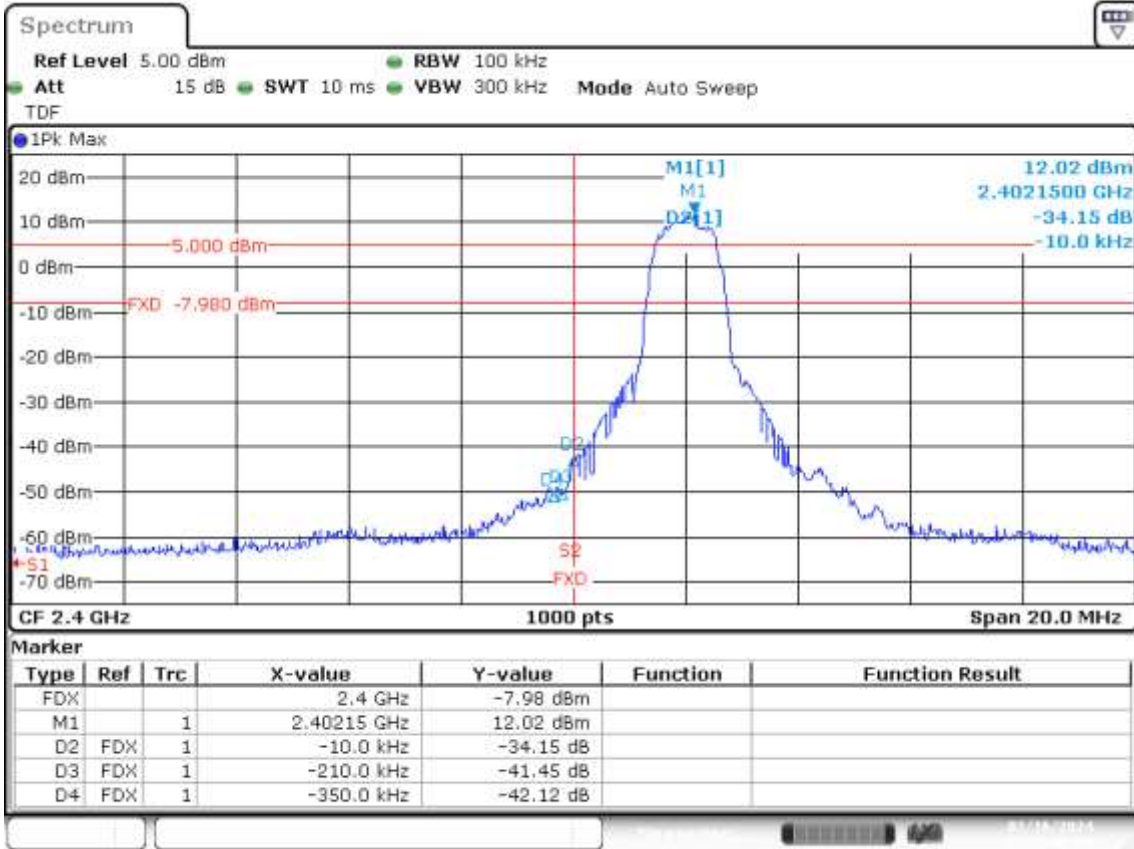

BE R Low Freq Section – CH0

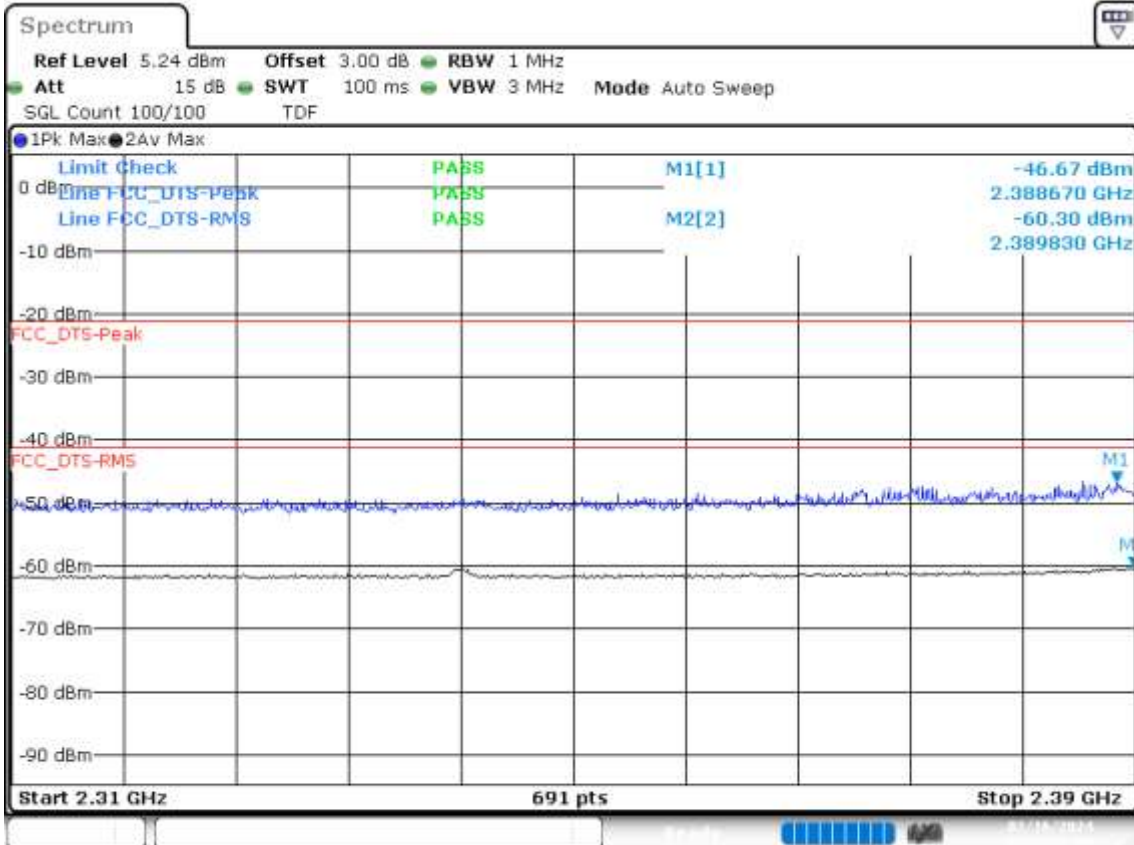

BE R High Freq Section – CH78

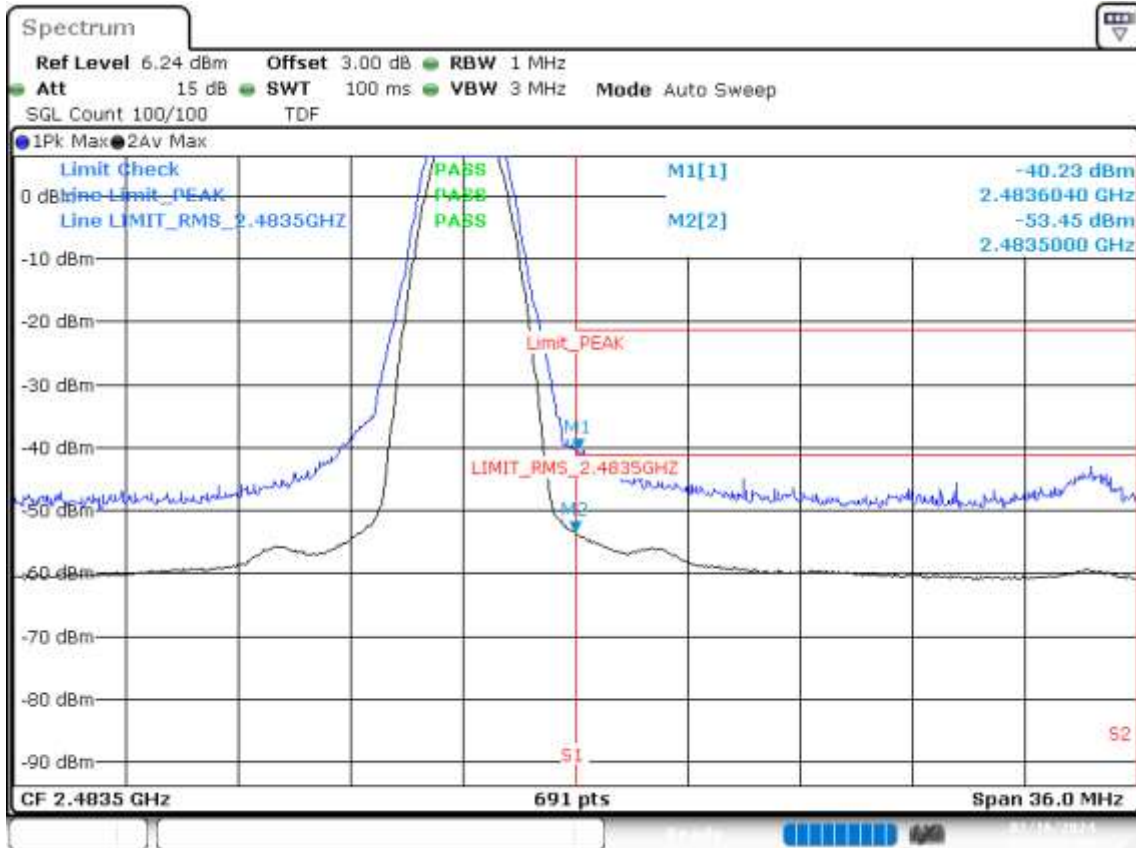

BE R Low Freq Section – Hopping

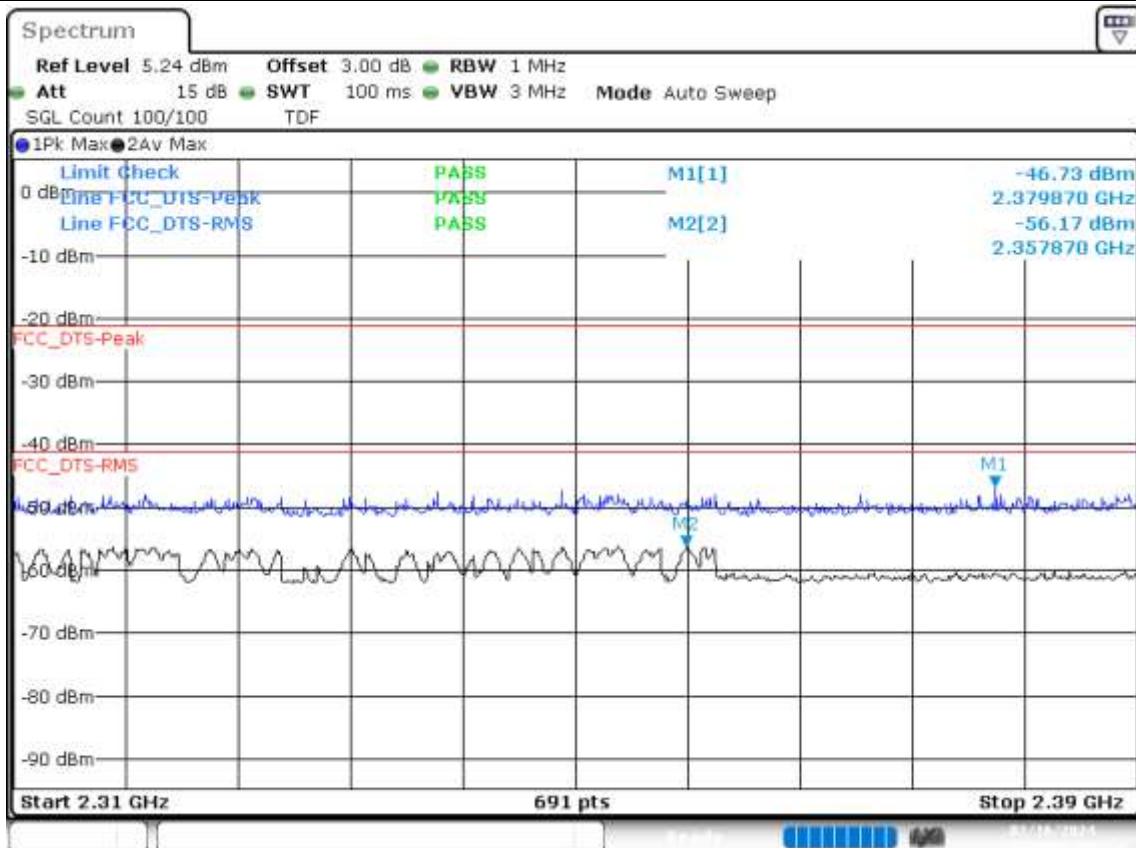

BE R High Freq Section – Hopping



B.6 Radiated spurious emission

B.6.1 Standards references

FCC part	RSS part	Limits																					
15.247 (d) 15.209 (a)	RSS-247 Clause 5.5 RSS GEN A1 Clause 8.9	Radiated emissions which fall in the restricted bands, as defined in §15.205(a), must also comply with the radiated emission limits specified in §15.209(a):																					
		<table border="1"> <thead> <tr> <th data-bbox="627 510 783 573">Freq Range (MHz)</th> <th data-bbox="826 510 983 573">Field Strength ($\mu\text{V}/\text{m}$)</th> <th data-bbox="1026 510 1182 573">Field Strength ($\text{dB}\mu\text{V}/\text{m}$)</th> <th data-bbox="1225 510 1382 573">Meas. Distance (m)</th> </tr> </thead> <tbody> <tr> <td data-bbox="667 577 743 607">30-88</td> <td data-bbox="898 577 911 607">100</td> <td data-bbox="1098 577 1118 607">40</td> <td data-bbox="1305 577 1318 607">3</td> </tr> <tr> <td data-bbox="683 611 727 640">88-216</td> <td data-bbox="898 611 911 640">150</td> <td data-bbox="1082 611 1134 640">43.5</td> <td data-bbox="1305 611 1318 640">3</td> </tr> <tr> <td data-bbox="675 645 735 674">216-960</td> <td data-bbox="898 645 911 674">200</td> <td data-bbox="1098 645 1118 674">46</td> <td data-bbox="1305 645 1318 674">3</td> </tr> <tr> <td data-bbox="667 678 743 707">Above 960</td> <td data-bbox="898 678 911 707">500</td> <td data-bbox="1098 678 1118 707">54</td> <td data-bbox="1305 678 1318 707">3</td> </tr> </tbody> </table>	Freq Range (MHz)	Field Strength ($\mu\text{V}/\text{m}$)	Field Strength ($\text{dB}\mu\text{V}/\text{m}$)	Meas. Distance (m)	30-88	100	40	3	88-216	150	43.5	3	216-960	200	46	3	Above 960	500	54	3	Field Strength ($\mu\text{V}/\text{m}$)
Freq Range (MHz)	Field Strength ($\mu\text{V}/\text{m}$)	Field Strength ($\text{dB}\mu\text{V}/\text{m}$)	Meas. Distance (m)																				
30-88	100	40	3																				
88-216	150	43.5	3																				
216-960	200	46	3																				
Above 960	500	54	3																				
The emission limits shown in the above table are based on measurements employing CISPR quasi-peak detector except for the frequency bands above 1000 MHz. Radiated emission limits in these three bands are based on measurements employing an average detector. For average radiated emission measurements above 1000 MHz, there is also a limit specified when measuring with peak detector function, corresponding to 20 dB above the indicated values in the table.																							

B.6.2 Test procedure

The radiated setups shown in section *Test & System Description* were used to measure the radiated spurious emissions.

Depending of the frequency range and bands being tested, different antennas and filters were used.

The final measurement is done by varying the antenna height from 1 m to 4 m, the EUT azimuth over 360° and for both Vertical and Horizontal polarizations.

The radiated spurious emission was measured on the worst case configuration found.

Test Results

Radiated spurious - 30 MHz to 1 GHz**All modes**

Frequency	Level	Detector	Limit	Margin	Polar
MHz	dBµV/m	---	dBµV/m	dB	---
51.1	36.9	Quasi-Peak	40.0	3.1	V
51.3	37.4	Quasi-Peak	40.0	2.6	V
51.4	37.7	Quasi-Peak	40.0	2.3	V

Note 1: The spurious signals detected do not depend on either the operating channel or the modulation mode.

1 GHz – 26 GHz, BR – GFSK**Radiated Spurious – CH0 DH5**

Frequency	Level	Detector	Limit	Margin	Polar
MHz	dBµV/m	---	dBµV/m	dB	---
10035.9	59.0	Peak	74.0	15.0	H
10035.9	47.8	Average	54.0	6.2	V
12039.9	47.1	Peak	74.0	26.9	V
12039.9	35.6	Average	54.0	18.4	V
25635.0	51.3	Peak	74.0	22.7	H
25635.0	39.3	Average	54.0	14.7	V

Radiated Spurious – CH39 DH5

Frequency	Level	Detector	Limit	Margin	Polar
MHz	dBµV/m	---	dBµV/m	dB	---
10041.7	59.4	Peak	74.0	14.6	V
10041.7	48.0	Average	54.0	6.0	V
12049.6	35.6	Average	54.0	18.4	V
12050.0	47.2	Peak	74.0	26.8	V
25592.5	51.3	Peak	74.0	22.7	H
25592.5	39.4	Average	54.0	14.7	H

Radiated Spurious – CH78 DH5

Frequency	Level	Detector	Limit	Margin	Polar
MHz	dB μ V/m	---	dB μ V/m	dB	---
10019.6	59.2	Peak	74.0	14.8	H
10019.6	47.8	Average	54.0	6.2	V
12050.8	46.9	Peak	74.0	27.1	V
12051.1	35.7	Average	54.0	18.3	V
25891.0	50.9	Peak	74.0	23.1	H
25891.0	39.4	Average	54.0	14.6	V

30 MHz – 26.5 GHz, EDR – $\pi/4$ -DQPSK

Radiated Spurious – CH0 2DH5

Frequency	Level	Detector	Limit	Margin	Polar
MHz	dB μ V/m	---	dB μ V/m	dB	---
10030.2	59.3	Peak	74.0	14.7	H
10030.2	47.7	Average	54.0	6.3	V
12050.8	35.8	Average	54.0	18.2	V
12054.1	48.3	Peak	74.0	25.7	V
25503.5	51.8	Peak	74.0	22.2	V
25504.0	39.3	Average	54.0	14.7	H

Radiated Spurious – CH39 2DH5

Frequency	Level	Detector	Limit	Margin	Polar
MHz	dB μ V/m	---	dB μ V/m	dB	---
10011.0	59.4	Peak	74.0	14.6	H
10011.0	47.6	Average	54.0	6.4	H
12050.4	46.8	Peak	74.0	27.2	V
12051.9	35.4	Average	54.0	18.6	V
25607.5	51.4	Peak	74.0	22.6	V
25608.0	39.5	Average	54.0	14.5	V

Radiated Spurious – CH78 2DH5

Frequency	Level	Detector	Limit	Margin	Polar
MHz	dB μ V/m	---	dB μ V/m	dB	---
9996.6	47.1	Average	54.0	6.9	H
9996.6	61.5	Peak	74.0	12.5	V
12050.8	46.0	Peak	74.0	27.9	V
12050.8	35.7	Average	54.0	18.3	V
25905.0	50.4	Peak	74.0	23.6	V
25906.0	39.3	Average	54.0	14.7	V

30 MHz – 26.5 GHz, EDR – 8-DPSK

Radiated Spurious – CH0 3DH5

Frequency	Level	Detector	Limit	Margin	Polar
MHz	dB μ V/m	---	dB μ V/m	dB	---
10103.0	61.6	Peak	74.0	12.4	H
10103.0	47.9	Average	54.0	6.1	H
12036.5	35.9	Average	54.0	18.1	V
12036.9	46.0	Peak	74.0	28.0	V
25600.5	51.3	Peak	74.0	22.7	V
25602.0	39.4	Average	54.0	14.6	V

Radiated Spurious – CH39 3DH5

Frequency	Level	Detector	Limit	Margin	Polar
MHz	dB μ V/m	---	dB μ V/m	dB	---
10027.3	60.4	Peak	74.0	13.6	H
10027.3	47.8	Average	54.0	6.2	H
12033.9	47.8	Peak	74.0	26.2	V
12036.9	36.0	Average	54.0	18.0	V
25517.0	39.4	Average	54.0	14.6	V
25518.0	51.4	Peak	74.0	22.6	H

Radiated Spurious – CH78 3DH5

Frequency	Level	Detector	Limit	Margin	Polar
MHz	dB μ V/m	---	dB μ V/m	dB	---
10134.6	59.7	Peak	74.0	14.3	H
10134.6	48.0	Average	54.0	6.0	V
12066.9	45.9	Peak	74.0	28.1	V
12066.9	35.9	Average	54.0	18.1	V
25900.0	50.7	Peak	74.0	23.3	V
25900.0	39.3	Average	54.0	14.7	V