



TEST REPORT

COMPLIANCE TEST REPORT

EUT Description	Wireless Module installed in Convertible PC
Brand Name	Intel® BE200NGW
Model Name	BE200NGW
FCC ID	PD9BE200NG
Date of Test Start/End	2023-12-27 / 2023-12-27
Features	2x2 Wi-Fi - IEEE 802.11be - Bluetooth®
Description	Platform: HSN-I61C

Applicant	Intel Corporation SAS
Address	425 Rue de Goa – Le Cargo B6 – 06600 Antibes, FRANCE
Contact Person	Benjamin Lavenant
Telephone/Fax/ Email	Benjamin.lavenant@intel.com

Test Report identification	231128-02.TR05
Revision Control	Rev. 01 This test report replaces any previous versions of this test report (see Section 1)

The test results relate only to the samples tested.

Reviewed by _____

Zayd OUACHICHA
(Technical Manager)

Intel Corporation S.A.S – WRF Lab
425 rue de Goa – Le Cargo B6 - 06600, Antibes, France
Tel. +33493001400 / Fax +33493001401

Table of Contents

1. General conditions, competences and guarantees	3
2. Environmental Conditions	3
3. Test Sample	3
4. EUT Features	4
5. Remarks and comments	4
6. Document Revision History	4
Annex A. Test & System description	5
A.1 TEST SETUP.....	5
A.2 TEST EQUIPMENT LIST.....	5
Annex B. Test Results	6
B.1 SAR TUNE-UP POWER AS PER SAR ASSESSMENT	6
B.2 TAS VALIDATION FOR 2.4 GHZ BAND ON CHANNEL 6.....	6
B.3 TAS VALIDATION FOR 5 GHZ BAND ON CHANNEL 120	8

1. General conditions, competences and guarantees

- ✓ Intel WRF Lab only provides testing services and is committed to providing reliable, unbiased test results and interpretations.
- ✓ Intel WRF Lab is liable to the client for the maintenance of the confidentiality of all information related to the item under test and the results of the test.
- ✓ Intel WRF Lab has developed calibration and proficiency programs for its measurement equipment to ensure correlated and reliable results to its customers.
- ✓ This report is only referred to the item that has undergone the test.
- ✓ This report does not imply an approval of the product by the Certification Bodies or competent Authorities.

2. Environmental Conditions

- ✓ At the site where the measurements were performed the following limits were not exceeded during the tests:

Temperature	24.07+/- 0.5 °C
Humidity	39.00 +/- 3.4 %

3. Test Sample

Sample	ID #	Description	Model	Serial #	Note
#1	231128-02.S05	Wireless Module installed in Convertible PC	HSN-I61C	00033770D7M	-

4. EUT Features

The herein information is provided by the customer.

Brand Name	Intel® BE200NGW	
Model Name	BE200NGW	
Software Version	DRTU.05055.23.0.0	
Driver Version	23.0.6.4	
Prototype / Production	Production	
Host Identification	HSN-I61C	
Supported Radios	802.11b/g/n/ax/be	2.4GHz (2400.0 – 2483.5 MHz)
	802.11a/n/ac/ax/be	5.2GHz (5150.0 – 5350.0 MHz)
		5.6GHz (5470.0 – 5725.0 MHz)
		5.8GHz (5725.0 – 5850.0 MHz)
		5.9GHz (5850.0 – 5895.0 MHz)
	802.11ax/be	6.0GHz (5925.0 – 6425.0 MHz)
	Bluetooth	2.4GHz (2400.0 – 2483.5 MHz)

5. Remarks and comments

1. The test report is a validation of the FCC TAS algorithm

6. Document Revision History

Revision #	Date	Modified by	Revision Details
Rev.00	2024-01-26	Yamine HADDAD	First Issue
Rev.01	2024-02-02	Zayd OUACHICHA	Model name updated.

Annex A. Test & System description

A.1 Test Setup

The conducted power measurement test setup is described in the following and illustrated in Figure A.1.

- The DUT which BE200NGW Wi-Fi module is installed inside Convertible PC from HP model HSN-I61C.
- A control PC is used to configure the call box as an access point to manage the uplink and downlink data traffic.
- Uplink signal power is measured with the spectrum analyzer and recorded by the PC with a maximum time resolution of 0.3333 msec.
- Uplink signal from the module is fed through a 3 dB power splitter, which delivers an equal amount of signal to the spectrum analyzer and the call box. The splitter has high isolation between the spectrum analyzer and the call box.

Figure.1 – Validation using conducted power measurement test setup.

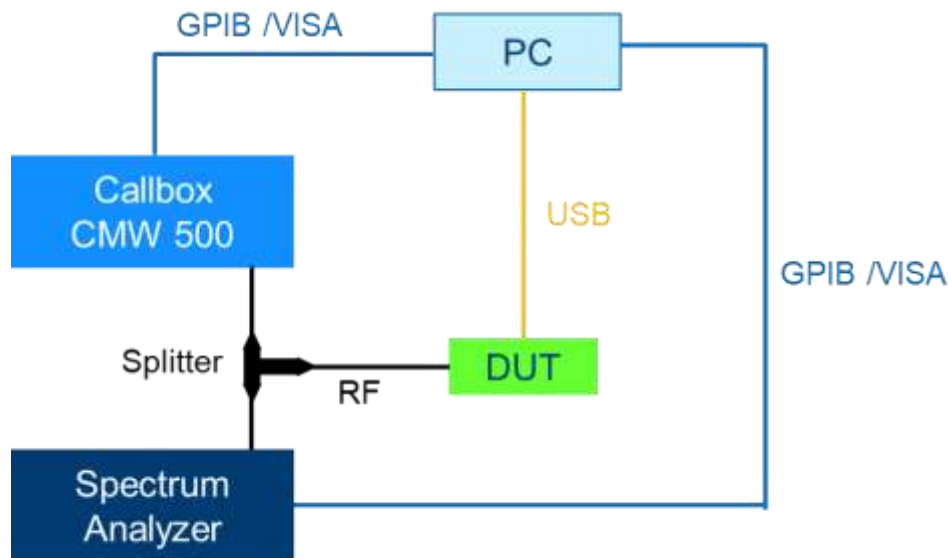

A.2 Test Equipment List

Equipment and accessories used for the conducted power measurement test setup are listed below. The Test Platform (DUT), test setup and associated equipment are shown in A.1.3.

ID#	Device	Type/Model	Serial #	Manufacturer	Cal. Date	Cal. Due Date
025-005	Communication Tester	CMW500	161493	Rohde & Schwarz	N/A	N/A
265-000	Spectrum Analyzer	FSV30	101318	Rohde & Schwarz	2023-03-29	2025-03-29
455-001	RF Cable	-	-	-	2023-02-23	2024-02-23
455-002	RF Cable	-	-	-	2023-02-23	2024-02-23
455-003	RF Splitter	-	-	-	2023-02-23	2024-02-23

Annex B. Test Results

B.1 SAR Tune-Up Power as per SAR assessment

Chain A		Chain B	
IEEE 802.11g CH6	IEEE 802.11a CH120	IEEE 802.11g CH6	IEEE 802.11a CH120
16.00	13.00	16.00	13.00

B.2 TAS Validation for 2.4 GHz Band on Channel 6

Table B1 – Test Cases for 2.4 GHz Channel 6

Test Case #	Channel	Chain	Channel Bandwidth	Measurement Averaging Period	Measurement Time Resolution	Max Tune-Up Power [dBm]	SAR Power in Bios Table [dBm]
1	6	A	20 MHz	100 sec	0.3333 msec	22.00	16.00
2	6	B	20 MHz	100 sec	0.3333 msec	22.00	16.00

Table B1 are shown in the following plots.

Case #1: 2.4 GHz– Ch 6 – Chain A – BW 20 MHz – Rate 12 Mbps Averaging Period 100 sec – Tmax 720 sec	
<i>Max Tune Up Power</i> [dBm]	<i>SAR Power in Bios Table</i> [dBm]
22.00	16.00

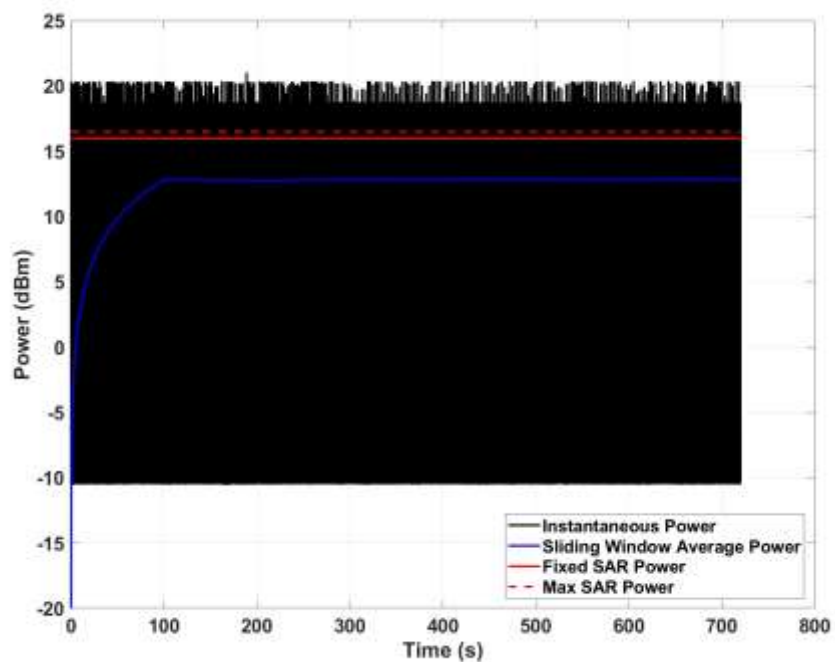

Case #2: 2.4 GHz– Ch 6 – Chain B – BW 20 MHz – Rate 12 Mbps Average Period 100 sec – Tmax 720 sec	
<i>Max Tune Up Power</i> [dBm]	<i>SAR Power in Bios Table</i> [dBm]
22.00	16.00

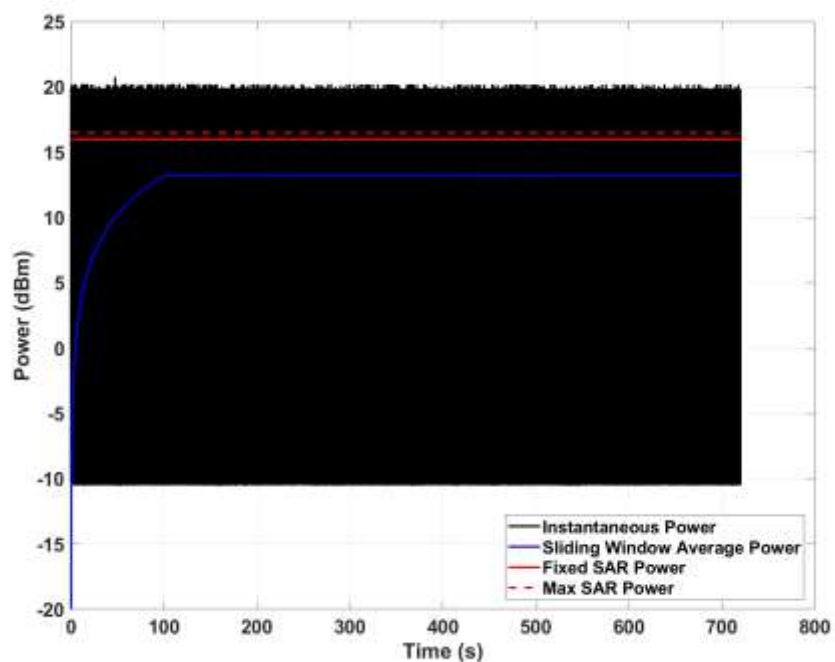

B.3 TAS Validation for 5 GHz Band on Channel 120*Table B2 – Test Cases for 5 GHz Channel 120*

<i>Test Case #</i>	<i>Channel</i>	<i>Chain</i>	<i>Channel Bandwidth</i>	<i>Measurement Averaging Period</i>	<i>Measurement Time Resolution</i>	<i>Max Tune-Up Power [dBm]</i>	<i>SAR Power in Bios Table [dBm]</i>
1	120	A	20 MHz	60 sec	0.3333 msec	21.25	13.00
2	120	B	20 MHz	60 sec	0.3333 msec	21.25	13.00

Table B2 are shown in the following plots.

Case #1: 5 GHz– Ch 120 – Chain A– BW 20 MHz – Rate 12 Mbps Averaging Period 60 sec – Tmax 720 sec	
<i>Max Tune-Up Power</i> [dBm]	<i>SAR Power in Bios Table</i> [dBm]
21.25	13.00

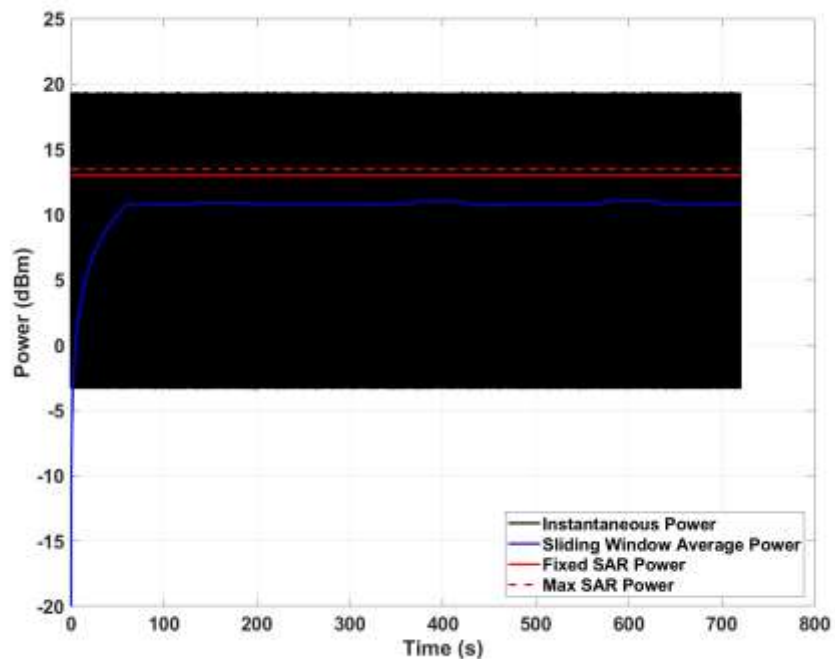

Case #2: 5 GHz– Ch 120 – Chain B – BW 20 MHz – Rate 12 Mbps Average Period 60 sec – Tmax 720 sec	
<i>Max Tune-Up Power</i> [dBm]	<i>SAR Power in Bios Table</i> [dBm]
21.25	13.00

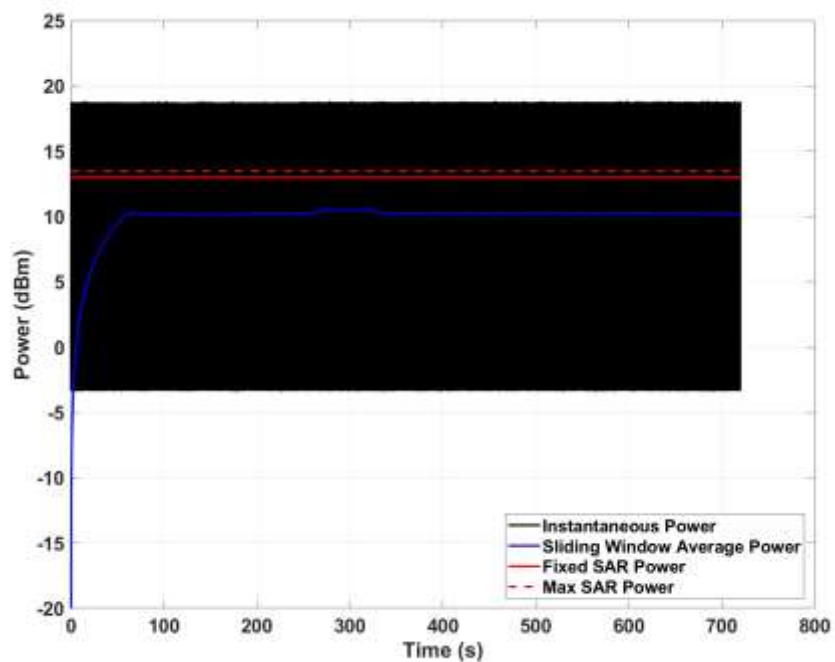

End of the report

This page is left intentionally blank and marks the last page of the test report.