

TEST REPORT

EUT Description	2x2 Wi-Fi and BT, M.2 2230 adapter card
Brand Name	Intel® AX211NGW
Model Name	AX211NGW
FCC ID / IC ID	PD9AX211NG ; 1000M-AX211NG
Date of Test Start/End	2023-07-18/ 2024-03-05
Features	2x2 Wi-Fi - IEEE 802.11ax - Bluetooth® (see section 5)

Applicant	Intel Corporation SAS
Address	425 Rue de Goa – Le Cargo B6 – 06600 Antibes, FRANCE
Contact Person	Benjamin Lavenant
Telephone/Fax/ Email	Benjamin.lavenant@intel.com

Reference Standards	FCC CFR Title 47 Part 15 E RSS-248 issue 2, RSS-Gen issue 5 - A1 (see section 1)
---------------------	--

Test Report identification	221108-01.TR02
Revision Control	Rev. 01 This test report revision replaces any previous test report revision (see section 8)

The test results relate only to the samples tested.
Reference to accreditation shall be used only by full reproduction of test report.

Issued by

Reviewed by

Cedric REQUIN
(Test Engineer Lead)

Zayd OUACHICHA
(Technical Manager)

Intel Corporation S.A.S – WRF Lab
425 rue de Goa – Le Cargo B6 - 06600, Antibes, France
Tel. +33493001400 / Fax +33493001401

Table of Contents

TEST REPORT	1
1. Standards, reference documents and applicable test methods	3
2. General conditions, competences and guarantees	3
3. Environmental Conditions	3
4. Test samples	4
5. EUT Features	5
6. Remarks and comments	5
7. Test Verdicts summary	6
7.1. 802.11 be – U-NII-5 to U-NII-7	6
8. Document Revision History	6
Annex A. Test & System Description	7
A.1 Measurement System	7
A.2 Test Equipment List	8
A.3 Measurement Uncertainty Evaluation	9
Annex B. Test Results	10
B.1 Test Conditions	10
B.2 Test Results Tables	11
B.2.1 26dB & 99% Bandwidth	11
B.2.2 Maximum Output power & Maximum power spectral Density	15
B.2.3 Emissions mask	27
B.2.4 Frequency stability	28
B.2.5 Contention-based protocol	29
B.2.6 Undesirable emission limits : Conducted	30
B.2.7 Dual Client Test, Demonstration of Proper Power Adjustment based on Associated AP	31
B.2.8 Proper Power Adjustment, Client Devices Connected to a Standard Power Access Point	32
Annex C. System Plots	33
C.1.1 26dB & 99% bandwidth	33
C.1.2 Maximum Output Power & Maximum power spectral Density	38
C.1.3 In-Band Emissions (Mask)	40
C.1.4 In-Band Emissions (Mask) Undesirable emission limits : out of band (Conducted)	54
C.1.5 Dual Client Test, Demonstration of Proper Power Adjustment based on Associated AP	74
C.1.6 Proper Power Adjustment, Client Devices Connected to a Standard Power Access Point	75
Annex D. Photographs	77
D.1 Test Setup	77
D.2 Test Sample	78

1. Standards, reference documents and applicable test methods

FCC	<ol style="list-style-type: none"> 1. FCC Title 47 eCFR part 15 – Subpart E - Unlicensed National Information Infrastructure Devices. 2021-10-01 edition 2. FCC OET KDB 987594 D01 U-NII 6GHz General Requirements v01r02 3. FCC OET KDB 987594 D02 U-NII 6 GHz EMC Measurement v01r01 4. FCC OET KDB 987594 D03 U-NII 6 GHz QA v01 5. FCC OET KDB 987594 D04 UN6GHZ Pre-Approval Guidance Checklist v01 6. FCC OET KDB 789033 D02 v02r01 - General U-NII Test Procedures New Rules – Guidelines for compliance testing of Unlicensed National Information Infrastructure (U-NII) Devices. 7. FCC OET KDB 662911 D01 v02r01 - Emissions Testing of Transmitters with Multiple Outputs in the Same Band. 8. ANSI C63.10-2013 American National Standard of Procedures for Compliance Testing of Unlicensed Wireless Devices.
ISED	<ol style="list-style-type: none"> 1. RSS-248 Issue 2 - Radio Local Area Network (RLAN) Devices operating in the 5925-7125 MHz band. 2. RSS-Gen Issue 5 Amendment 1 - General Requirements for Compliance of Radio Apparatus. 3. FCC OET KDB 987594 D01 U-NII 6GHz General Requirements v01r02 4. FCC OET KDB 987594 D02 U-NII 6 GHz EMC Measurement v01r01 5. FCC OET KDB 987594 D03 U-NII 6 GHz QA v01 6. ANSI C63.10-2013 American National Standard of Procedures for Compliance Testing of Unlicensed Wireless Devices

2. General conditions, competences and guarantees

- ✓ Tests performed under FCC standards identified in section 1 are covered by A2LA accreditation.
- ✓ Tests performed under ISED standards identified in section 1 are covered by Cofrac accreditation.
- ✓ Intel Corporation SAS Wireless RF Lab (Intel WRF Lab) is an ISO/IEC 17025:2017 laboratory accredited by the American Association for Laboratory Accreditation (A2LA) with the certificate number 3478.01.
- ✓ Intel Corporation SAS Wireless RF Lab (Intel WRF Lab) is an Accredited Test Firm recognized by the FCC, with Designation Number FR0011.
- ✓ Intel Corporation SAS Wireless RF Lab (Intel WRF Lab) is an ISO/IEC 17025:2017 testing laboratory accredited by the French Committee for Accreditation (Cofrac) with the certificate number 1-6736.
- ✓ Intel Corporation SAS Wireless RF Lab (Intel WRF Lab) is a Registered Test Site listed by ISED, with ISED #1000Y and CAB identifier FR0005.
- ✓ Intel WRF Lab only provides testing services and is committed to providing reliable, unbiased test results and interpretations.
- ✓ Intel WRF Lab is liable to the client for the maintenance of the confidentiality of all information related to the item under test and the results of the test.
- ✓ Intel WRF Lab has developed calibration and proficiency programs for its measurement equipment to ensure correlated and reliable results to its customers.
- ✓ This report is only referred to the item that has undergone the test.
- ✓ This report does not imply an approval of the product by the Certification Bodies or competent Authorities.

3. Environmental Conditions

- ✓ At the site where the measurements were performed the following limits were not exceeded during the tests:

Temperature	23.1°C ± 0.3°C
Humidity	44.4% ± 3%

4. Test samples

Sample	Control #	Description	Model	Serial #	Date of receipt	Note
#01	200611-01.S16	Module	AX211NGW	WFM:D8F883596CEE	2020-12-01	Used for RF conducted tests
	170000-01.S15	Laptop	Dell Latitude 6430U	8LGVLX1	2017-06-12	
	200611-01.S12	CRF CNVIO DB M2 Extender Board	PCB00651_01	6515219-184	2020-11-30	
#02	200611-01.S14	WiFi 6E Module	AX211NGW	WFM: 988D46EFD53F	2020-09-18	Used for Frequency Stability tests
	170000-01.S19	Laptop	Latitude E5450	4TXV562	2020-02-04	
	200611-01.S19	Extender	PCB00651_01	-	2021-06-02	
#03	200611-01.S14	WiFi 6E Module	AX211NGW	WFM: 988D46EFD53F	2020-09-18	Used for CBP Test
	170000-01.S18	Laptop	Latitude E5470	4L1BVF2	2019-05-23	
	191003-02.S04	Extender	PCB00651_01	-	2019-10-29	
#04	200611-01.S14	Module	AX211NGW	WFM:D8F883596D5C	2020-12-01	Used for Dual Client Test and Proper Power Adjustment
	210903-02.S52	Laptop	Latitude E5450	GTXV562	2018-01-18	
	200611-01.S10	CRF CNVIO DB M2 Extender Board	PCB00651_01	N/A	2020-11-30	

5. EUT Features

The herein information is provided by the customer.

Intel WRF Lab declines any responsibility for the accuracy of the stated customer provided information, especially if it has any impact on the correctness of test results presented in this report.

Brand Name	Intel® AX211NGW		
Model Name	AX211NGW		
Software Version	DRTU.04971.99.0.82		
Driver Version	xVT 99.0.82.1 / 23.30.0.4		
Supported Radios	802.11b/g/n/ax	2.4GHz (2400.0 – 2483.5 MHz)	
	802.11a/n/ac/ax	5.2GHz (5150.0 – 5350.0 MHz)	
		5.6GHz (5470.0 – 5725.0 MHz)	
		5.8GHz (5725.0 – 5850.0 MHz)	
		5.9GHz (5850.0 – 5925.0MHz)	
802.11ax	6.0GHz (5925.0 – 7125.0MHz)		
Bluetooth	2.4GHz (2400.0 – 2483.5 MHz)		
Antenna Information	Transmitter	Main(2)/Chain A	Aux(1)/Chain B
	Manufacturer	Intel WRF Lab	Intel WRF Lab
	Antenna type	PIFA	PIFA
	Part number	WRF-Tri Band-Antenna	WRF-Tri Band-Antenna
	Declared Antenna peak gain (dBi)	5.59	5.59

6. Remarks and comments

1. No deviations were made from the test methods listed in section 1 of this report.
2. Only the worst-case plot per Bandwidth and test case measurements have been reported excepted for band edge measurements where all plots are reported.
3. This report only presents conducted measurements, for radiated spurious measurements refer to report: 200611-01.TR39
4. Full and Partial RU's are supported. Full RU was completely tested as this was considered worse case. Target powers for Full are higher than partial RU. Spot checking was done to confirm this during testing for power and PSD. Complete partial RU testing is provided as part of the emissions mask.

7. Test Verdicts summary

The statement of conformity to applicable standards in the table below are based on the measured values, without taking into account the measurement uncertainties.

7.1. 802.11 be – U-NII-5 to U-NII-7

FCC part	RSS clause	Test name	Verdict
15.407 (a) (10)	RSS-248 Clause 4.4	Occupied Bandwidth	P
15.407 (a) (8)	RSS-248 Clause 4.5	Maximum output power	P
15.407 (a) (8)	RSS-248 Clause 4.5	Power spectral density	P
15.407 (b) (5)	RSS-248 Clause 4.6	Undesirable emissions limits: out of band (conducted)	P
15.407 (b) (6)	RSS-248 Clause 4.6	In-Band Emissions (Mask)	P
15.407 (d) (6)	RSS-248 Clause 4.7	Contention based protocol	P
15.407(g)	RSS-Gen Issue 5 Amendment 1 – clause 6.11	Frequency Stability	P
15.407(d)	RSS-248 Clause 4.8	Dual Client Test	P
15.407(d)	RSS-248 Clause 4.8.3	Proper power adjustment	P

P: Pass

F: Fail

NM: Not Measured

NA: Not Applicable

8. Document Revision History

Revision #	Modified by	Revision Details
Rev. 00	T.MATHIEU	First Issue
Rev. 01	T.MATHIEU	Adding Proper Power Adjustment test case in Section B.2.8

Annex A. Test & System Description

A.1 Measurement System

Measurements were performed using these following setups.

The DUT was installed in a test fixture and this test fixture is connected to a laptop computer and AC/DC power adapter. The laptop computer was used to configure the EUT to continuously transmit at a specified output power using all different modes and modulation schemes, using the Intel proprietary tool DRTU.

Conducted test setup except frequency stability

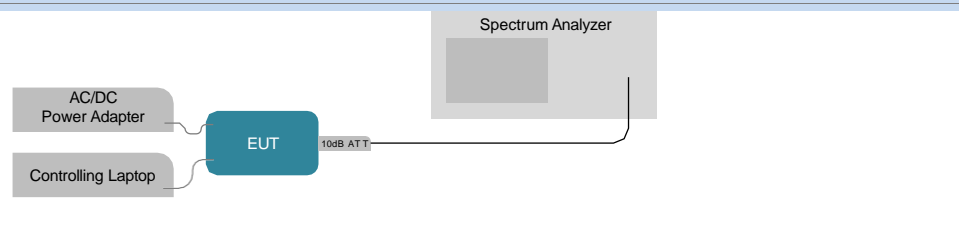

Contention-based protocol

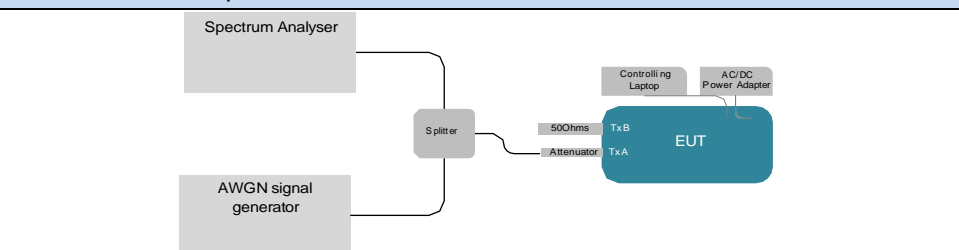

Frequency stability (Normal & Extreme conditions)

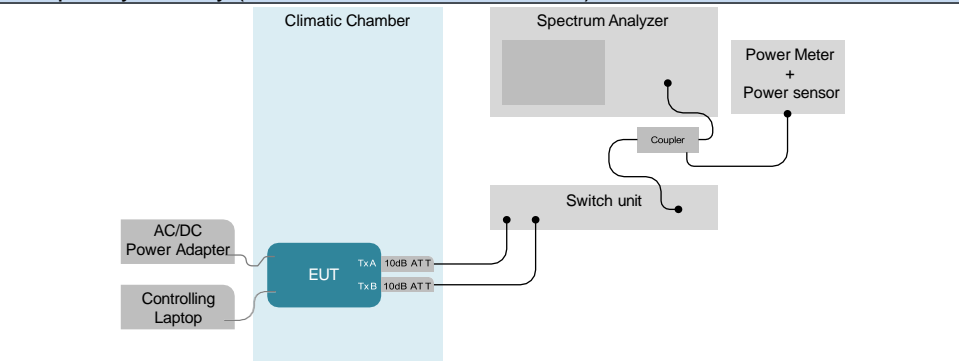

Dual Client Test, Demonstration of Proper Power Adjustment based on Associated AP

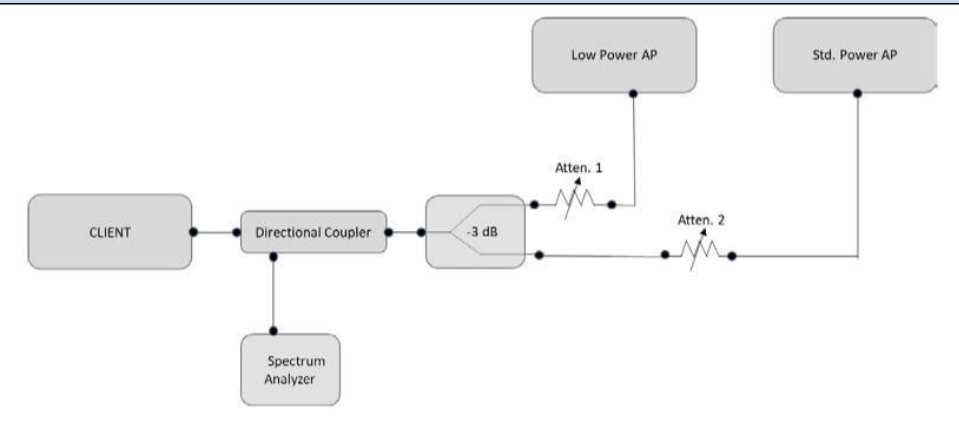

A.2 Test Equipment List

Conducted setup

ID#	Device	Type/Model	Serial #	Manufacturer	Cal. Date	Cal. Due Date
134-000	Spectrum Analyzer	FSV30	103308	Rohde & Schwarz	2023-07-26	2025-07-26
019-000*	RF cable 100cm	PE360-100	N/A	PASTERNAK	2023-03-03	2024-03-03
019-002*	10dB Attenuator + MH4	PE7395-10	N/A	PASTERNAK	2023-03-03	2024-03-03
407-000	Temp & Humidity Logger	RA12E-TH1-RAS	RA12-E16EDA	AVITECH	2023-07-12	2025-07-12
413-000	Measurement SW v1.5.4.2	Octopi	N/A	Step AT	N/A	N/A

* Equipment not used during out of calibration period

N/A: not applicable

Contention-based protocol

ID#	Device	Type/Model	Serial #	Manufacturer	Cal. Date	Cal. Due Date
098-000*	Vector Signal generator	SMW200A	103732	Rohde & Schwarz	2020-07-20	2022-07-20
134-000*	Spectrum Analyzer	FSV13	103308	Rohde & Schwarz	2021-04-21	2023-04-21
018-004*	50 Ohm Load	-	-	-	2021-08-24	2022-02-24
018-000*	2 Way SMA Power Divider	PE2084	-	Pasternack	2021-08-24	2022-02-24
349-000*	Temp & Humidity Logger	RA12E-TH1-RAS	RA12-D4F8C3	Avtech	2021-07-30	2023-07-30
018-005*	Cable SMA Male to SMA Male 45CM	FMC0202085-18	-	Fairview Microwave	2021-08-24	2022-02-24
018-006*	Cable SMA Male to SMA Male 45CM	FMC0202085-18	-	Fairview Microwave	2021-08-24	2022-02-24
016-003*	Cable SMA Male to SMA Male 45CM	FMC0202085-18	-	Fairview Microwave	2021-08-24	2022-02-24

* Equipment not used during out of calibration period

N/A: Not Applicable

Frequency stability

ID#	Device	Type/Model	Serial #	Manufacturer	Cal. Date	Cal. Due Date
017-015*	Switch unit	OSP 120	100945	Rohde & Schwarz	2020-04-21	2022-04-21
017-003	DC Power supply	E3640A	MY40006885	Agilent	N/A	N/A
060-000*	Multimeter	34401A	US36054685	Agilent	2020-10-26	2022-10-26
311-000*	Climatic chamber	SLT34/40	56746020930010	Secasi	2021-12-13	2023-12-13
280-000*	Spectrum analyzer	FSV30	103310	Rohde & Schwarz	2020-06-03	2022-06-03
017-000	Measurement Software	WMS 32 v11.00.00	200226	Rohde & Schwarz	N/A	N/A
322-000*	Temp & Humidity Logger	RA12E-TH1-RAS	RA12-B89702	AVTECH	2021-09-02	2023-09-02
237-000*	10dB directional coupler	MC2047-10	01-062	Fairview	2021-08-26	2022-02-26
017-005*	RF Cable 0.5m	PE3CA1039	-	Pasternack	2021-08-26	2022-02-26
017-007*	Cable SMA Male to ML51-P	HRMP-ML51LP	DTR178-100RS	Hirose	2021-08-26	2022-02-26
017-008*	Cable SMA Male to ML51-P	HRMP-ML51LP	DTR178-100RS	Hirose	2021-08-26	2022-02-26
053-000*	Thermometer	t3000FC	46320032	Fluke	2021-11-15	2023-11-15
017-011*	RF Cable 2m	0900670672000PJ	1936949	Radiall	2021-08-26	2022-02-26
017-012*	RF Cable 2m	0900670672000PJ	1936947	Radiall	2021-08-26	2022-02-26
017-019*	10dB attenuator	-	-	Pasternack	2021-08-26	2022-02-26
017-020*	10dB attenuator	-	-	Pasternack	2021-08-26	2022-02-26

* Equipment not used during out of calibration period

N/A: not applicable

Dual Client

ID#	Device	Type/Model	Serial #	Manufacturer	Cal. Date	Cal. Due Date
R143-000*	Spectrum Analyzer	FSVA30	-	Rohde & Schwarz	2023-06-30	2023-09-30
220502-01.S03	Laptop	Inspiron15	9Y38GL3	DELL	NA	NA
200702-02.S03	Laptop	HP Cadillac (HSN-I41C-5)	00095002JP	HP	NA	NA
499-000*	Directional Coupler	PE2CP000-10-	2139	Pasternack	2022-09-12	2023-10-12
499-001*	Power Divider	PE2028	1640	Pasternack	2022-09-12	2023-10-12
499-002*	Power Divider	PE2028	1609	Pasternack	2022-09-12	2023-10-12
499-003*	Cable 1.80m K-K	E40-6FT-KMKM+	21101338	Mini-Circuits	2022-09-12	2023-10-12
499-004*	Cable 1.80m K-K	E40-6FT-KMKM+	21101364	Mini-Circuits	2022-09-12	2023-10-12
499-005*	Cable 1.80m K-K	E40-6FT-KMKM+	21101350	Mini-Circuits	2022-09-12	2023-10-12
018-007	Programmable Attenuator	RCDAT-8000-90	12111080069	Mini-Circuits	NA	NA
462-000	Attenuator	8495D	MY2144103	Agilent	NA	NA

*Equipment not used during out of calibration period

Proper Power Adjustment

ID#	Device	Type/Model	Serial #	Manufacturer	Cal. Date	Cal. Due Date
131-000	Spectrum Analyzer	FSV40	101425	Rohde & Schwarz	2022-07-10	2024-07-10
220502-01.S03	Laptop	Inspiron15	9Y38GL3	DELL	NA	NA
499-000	Directional Coupler	PE2CP000-10-	2139	Pasternack	2023-11-07	2024-11-07
499-001	Power Divider	PE2028	1640	Pasternack	2023-11-07	2024-11-07
499-002	Power Divider	PE2028	1609	Pasternack	2023-11-07	2024-11-07
499-003	Cable 1.80m K-K	E40-6FT-KMKM+	21101338	Mini-Circuits	2023-11-07	2024-11-07
499-004	Cable 1.80m K-K	E40-6FT-KMKM+	21101364	Mini-Circuits	2023-11-07	2024-11-07
499-005	Cable 1.80m K-K	E40-6FT-KMKM+	21101350	Mini-Circuits	2023-11-07	2024-11-07
018-007	Programmable Attenuator	RCDAT-8000-90	12111080069	Mini-Circuits	NA	NA
462-000	Attenuator	8495D	MY2144103	Agilent	NA	NA

A.3 Measurement Uncertainty Evaluation

The system uncertainty evaluation is shown in the table below with a coverage factor of $k = 2$ to indicate a 95% level of confidence:

Measurement type	Uncertainty	Unit
Timing	± 0.12	%
Power Spectral density	± 1.47	dB
Frequency stability	± 53.0	ppm
Occupied bandwidth	± 2.07	%
Conducted Power	± 1.03	dB
Temperature	± 0.30	°C
Supply voltages	$< \pm 0.01$	%
Contention Based Protocol	± 1.36	dB

Annex B. Test Results

The herein test results were performed by:

Test case measurement	Test Personnel
Maximum output power	T.MATHIEU
26dB and 99% Bandwidth measurement	T.MATHIEU
Maximum power spectral density	T.MATHIEU
Frequency stability	G.ROUSTAN
Undesirable emissions limits: out of band (conducted)	T.MATHIEU
In-Band Emissions Mask	T.MATHIEU
Contention-based Protocol	G.ROUSTAN
Dual Client Test, Demonstration of Proper Power Adjustment based on Associated AP)	T.MATHIEU

B.1 Test Conditions

For 802.11ax20 (20 MHz channel bandwidth), 802.11ax40 (40MHz channel bandwidth), 802.11ax80 (80MHz channel bandwidth), and 802.11ax160 (160MHz channel bandwidth) modes the EUT can transmit at both CHAIN A and CHAIN B RF outputs individually, and also simultaneously.

The following data rates were selected based on preliminary testing that identified those rates as the worst cases for output power and spurious levels at the band edges:

Transmission	Mode	Bandwidth (MHz)	Worst Case Data Rate
SISO	802.11ax	20	MCS0
		40	MCS0
		80	MCS0
		160	MCS0
MIMO	802.11ax	20/40/80/160	MCS0

B.2 Test Results Tables

B.2.1 26dB & 99% Bandwidth

Test limits

FCC part	RSS part	Limits
15.407 (a) (10)	RSS-248 Clause 4.4	The maximum transmitter channel bandwidth for U-NII devices in the 5.925-7.125 GHz band is 320 megahertz.

Test procedure

The conducted setup shown in section *Test & System Description* was used to measure the 26dB & 99% bandwidth. The antenna terminal of the EUT is connected to the spectrum analyzer through an attenuator, and the spectrum analyzer reading is compensated to include the RF path loss.

See Annex C.1.1 for the screenshot results¹

Results tables

Max value

Maximum bandwidth value highlighted per BW and channel bandwidth over uninterrupted UNII-5 – 7 bands

¹ Only the worst-case plots per BW and channel bandwidth were reported over uninterrupted UNII-5 – 7 bands

Band	Mode & BW[MHz]	Channel	Frequency [MHz]	Rate	RU config.	Antenna	26dB BW [MHz]	99% BW [MHz]
UNII5	802.11ax20	1	5955	MCS0	FullBW	SISO A	23.76	18.96
UNII5	802.11ax20	1	5955	MCS0	FullBW	SISO B	23.84	18.96
UNII5	802.11ax20	1	5955	MCS0	FullBW	MIMO A	24.32	18.88
UNII5	802.11ax20	1	5955	MCS0	FullBW	MIMO B	24.32	18.88
UNII5	802.11ax20	45	6175	MCS0	FullBW	SISO A	23.84	18.88
UNII5	802.11ax20	45	6175	MCS0	FullBW	SISO B	23.52	18.96
UNII5	802.11ax20	45	6175	MCS0	FullBW	MIMO A	23.68	19.04
UNII5	802.11ax20	45	6175	MCS0	FullBW	MIMO B	23.44	18.88
UNII5	802.11ax20	93	6415	MCS0	FullBW	SISO A	24.64	18.96
UNII5	802.11ax20	93	6415	MCS0	FullBW	SISO B	23.68	18.96
UNII5	802.11ax20	93	6415	MCS0	FullBW	MIMO A	24.16	18.96
UNII5	802.11ax20	93	6415	MCS0	FullBW	MIMO B	24.80	19.04
UNII5	802.11ax40	3	5965	MCS0	FullBW	SISO A	44.48	37.60
UNII5	802.11ax40	3	5965	MCS0	FullBW	SISO B	44.32	37.44
UNII5	802.11ax40	3	5965	MCS0	FullBW	MIMO A	45.28	37.60
UNII5	802.11ax40	3	5965	MCS0	FullBW	MIMO B	44.80	37.60
UNII5	802.11ax40	43	6165	MCS0	FullBW	SISO A	44.96	37.76
UNII5	802.11ax40	43	6165	MCS0	FullBW	SISO B	44.80	37.60
UNII5	802.11ax40	43	6165	MCS0	FullBW	MIMO A	45.28	37.60
UNII5	802.11ax40	43	6165	MCS0	FullBW	MIMO B	44.00	37.76
UNII5	802.11ax40	91	6405	MCS0	FullBW	SISO A	45.28	37.44
UNII5	802.11ax40	91	6405	MCS0	FullBW	SISO B	44.32	37.60
UNII5	802.11ax40	91	6405	MCS0	FullBW	MIMO A	44.64	37.44
UNII5	802.11ax40	91	6405	MCS0	FullBW	MIMO B	44.00	37.76
UNII5	802.11ax80	7	5985	MCS0	FullBW	SISO A	84.48	77.12
UNII5	802.11ax80	7	5985	MCS0	FullBW	SISO B	84.16	76.80
UNII5	802.11ax80	7	5985	MCS0	FullBW	MIMO A	83.52	76.80
UNII5	802.11ax80	7	5985	MCS0	FullBW	MIMO B	84.80	76.48
UNII5	802.11ax80	39	6145	MCS0	FullBW	SISO A	84.80	76.80
UNII5	802.11ax80	39	6145	MCS0	FullBW	SISO B	84.80	77.12
UNII5	802.11ax80	39	6145	MCS0	FullBW	MIMO A	84.16	76.80
UNII5	802.11ax80	39	6145	MCS0	FullBW	MIMO B	85.76	76.80
UNII5	802.11ax80	87	6385	MCS0	FullBW	SISO A	84.16	76.80
UNII5	802.11ax80	87	6385	MCS0	FullBW	SISO B	85.12	76.80
UNII5	802.11ax80	87	6385	MCS0	FullBW	MIMO A	84.16	77.12
UNII5	802.11ax80	87	6385	MCS0	FullBW	MIMO B	85.44	76.80
UNII5	802.11ax160	15	6025	MCS0	FullBW	SISO A	165.12	154.56
UNII5	802.11ax160	15	6025	MCS0	FullBW	SISO B	165.12	154.56
UNII5	802.11ax160	15	6025	MCS0	FullBW	MIMO A	165.12	154.88
UNII5	802.11ax160	15	6025	MCS0	FullBW	MIMO B	164.80	154.88
UNII5	802.11ax160	79	6345	MCS0	FullBW	SISO A	165.12	154.88
UNII5	802.11ax160	79	6345	MCS0	FullBW	SISO B	165.12	154.88
UNII5	802.11ax160	79	6345	MCS0	FullBW	MIMO A	164.80	154.88
UNII5	802.11ax160	79	6345	MCS0	FullBW	MIMO B	164.16	154.88

Band	Mode & BW[MHz]	Channel	Frequency [MHz]	Rate	RU config.	Antenna	26dB BW [MHz]	99% BW [MHz]
UNII6	802.11ax20	97	6435	MCS0	FullBW	SISO A	30.32	19.20
UNII6	802.11ax20	97	6435	MCS0	FullBW	SISO B	28.00	19.28
UNII6	802.11ax20	97	6435	MCS0	FullBW	MIMO A	32.16	19.28
UNII6	802.11ax20	97	6435	MCS0	FullBW	MIMO B	26.64	19.28
UNII6	802.11ax20	105	6475	MCS0	FullBW	SISO A	30.32	19.28
UNII6	802.11ax20	105	6475	MCS0	FullBW	SISO B	28.80	19.20
UNII6	802.11ax20	105	6475	MCS0	FullBW	MIMO A	28.48	19.28
UNII6	802.11ax20	105	6475	MCS0	FullBW	MIMO B	27.92	19.28
UNII6	802.11ax20	113	6515	MCS0	FullBW	SISO A	30.64	19.28
UNII6	802.11ax20	113	6515	MCS0	FullBW	SISO B	29.52	19.28
UNII6	802.11ax20	113	6515	MCS0	FullBW	MIMO A	32.96	19.28
UNII6	802.11ax20	113	6515	MCS0	FullBW	MIMO B	31.12	19.20
UNII6	802.11ax40	99	6445	MCS0	FullBW	SISO A	51.04	38.08
UNII6	802.11ax40	99	6445	MCS0	FullBW	SISO B	46.24	37.92
UNII6	802.11ax40	99	6445	MCS0	FullBW	MIMO A	78.08	38.56
UNII6	802.11ax40	99	6445	MCS0	FullBW	MIMO B	44.64	38.24
UNII6	802.11ax40	107	6485	MCS0	FullBW	SISO A	51.84	37.92
UNII6	802.11ax40	107	6485	MCS0	FullBW	SISO B	65.60	38.72
UNII6	802.11ax40	107	6485	MCS0	FullBW	MIMO A	70.24	38.40
UNII6	802.11ax40	107	6485	MCS0	FullBW	MIMO B	46.88	38.08
UNII6	802.11ax40	115	6525	MCS0	FullBW	SISO A	49.80	38.72
UNII6	802.11ax40	115	6525	MCS0	FullBW	SISO B	57.80	38.72
UNII6	802.11ax40	115	6525	MCS0	FullBW	MIMO A	98.40	45.76
UNII6	802.11ax40	115	6525	MCS0	FullBW	MIMO B	67.20	38.24
UNII6	802.11ax80	103	6465	MCS0	FullBW	SISO A	85.12	77.12
UNII6	802.11ax80	103	6465	MCS0	FullBW	SISO B	88.32	77.12
UNII6	802.11ax80	103	6465	MCS0	FullBW	MIMO A	86.40	77.12
UNII6	802.11ax80	103	6465	MCS0	FullBW	MIMO B	88.00	77.12
UNII6	802.11ax80	119	6545	MCS0	FullBW	SISO A	90.88	77.12
UNII6	802.11ax80	119	6545	MCS0	FullBW	SISO B	90.24	77.12
UNII6	802.11ax80	119	6545	MCS0	FullBW	MIMO A	84.80	77.12
UNII6	802.11ax80	119	6545	MCS0	FullBW	MIMO B	88.64	77.12
UNII6	802.11ax160	111	6505	MCS0	FullBW	SISO A	164.48	154.56
UNII6	802.11ax160	111	6505	MCS0	FullBW	SISO B	165.76	154.88
UNII6	802.11ax160	111	6505	MCS0	FullBW	MIMO A	229.44	155.52
UNII6	802.11ax160	111	6505	MCS0	FullBW	MIMO B	165.12	154.88

Band	Mode & BW [MHz]	Channel	Frequency [MHz]	Rate	RU config.	Antenna	26dB BW [MHz]	99% BW [MHz]
UNII7	802.11ax20	117	6535	MCS0	FullBW	SISO A	24.88	18.96
UNII7	802.11ax20	117	6535	MCS0	FullBW	SISO B	24.16	18.96
UNII7	802.11ax20	117	6535	MCS0	FullBW	MIMO A	24.72	18.96
UNII7	802.11ax20	117	6535	MCS0	FullBW	MIMO B	24.32	18.96
UNII7	802.11ax20	149	6695	MCS0	FullBW	SISO A	24.56	18.96
UNII7	802.11ax20	149	6695	MCS0	FullBW	SISO B	23.76	18.88
UNII7	802.11ax20	149	6695	MCS0	FullBW	MIMO A	24.64	18.96
UNII7	802.11ax20	149	6695	MCS0	FullBW	MIMO B	23.60	18.96
UNII7	802.11ax20	181	6855	MCS0	FullBW	SISO A	23.84	18.96
UNII7	802.11ax20	181	6855	MCS0	FullBW	SISO B	24.64	18.88
UNII7	802.11ax20	181	6855	MCS0	FullBW	MIMO A	24.80	18.96
UNII7	802.11ax20	181	6855	MCS0	FullBW	MIMO B	23.68	18.88
UNII7	802.11ax40	123	6565	MCS0	FullBW	SISO A	44.80	37.60
UNII7	802.11ax40	123	6565	MCS0	FullBW	SISO B	44.00	37.60
UNII7	802.11ax40	123	6565	MCS0	FullBW	MIMO A	43.84	37.44
UNII7	802.11ax40	123	6565	MCS0	FullBW	MIMO B	44.16	37.76
UNII7	802.11ax40	147	6685	MCS0	FullBW	SISO A	44.48	37.76
UNII7	802.11ax40	147	6685	MCS0	FullBW	SISO B	45.28	37.60
UNII7	802.11ax40	147	6685	MCS0	FullBW	MIMO A	44.96	37.76
UNII7	802.11ax40	147	6685	MCS0	FullBW	MIMO B	45.28	37.60
UNII7	802.11ax40	179	6845	MCS0	FullBW	SISO A	43.52	37.60
UNII7	802.11ax40	179	6845	MCS0	FullBW	SISO B	44.64	37.76
UNII7	802.11ax40	179	6845	MCS0	FullBW	MIMO A	45.60	37.76
UNII7	802.11ax40	179	6845	MCS0	FullBW	MIMO B	44.80	37.60
UNII7	802.11ax80	135	6625	MCS0	FullBW	SISO A	86.40	77.12
UNII7	802.11ax80	135	6625	MCS0	FullBW	SISO B	85.76	77.12
UNII7	802.11ax80	135	6625	MCS0	FullBW	MIMO A	83.84	77.12
UNII7	802.11ax80	135	6625	MCS0	FullBW	MIMO B	83.84	76.80
UNII7	802.11ax80	151	6705	MCS0	FullBW	SISO A	85.12	76.80
UNII7	802.11ax80	151	6705	MCS0	FullBW	SISO B	86.08	77.12
UNII7	802.11ax80	151	6705	MCS0	FullBW	MIMO A	85.76	77.12
UNII7	802.11ax80	151	6705	MCS0	FullBW	MIMO B	86.40	76.80
UNII7	802.11ax80	167	6785	MCS0	FullBW	SISO A	85.44	77.12
UNII7	802.11ax80	167	6785	MCS0	FullBW	SISO B	84.80	76.80
UNII7	802.11ax80	167	6785	MCS0	FullBW	MIMO A	85.76	77.12
UNII7	802.11ax80	167	6785	MCS0	FullBW	MIMO B	85.76	77.12
UNII7	802.11ax160	143	6665	MCS0	FullBW	SISO A	166.08	154.56
UNII7	802.11ax160	143	6665	MCS0	FullBW	SISO B	165.44	154.88
UNII7	802.11ax160	143	6665	MCS0	FullBW	MIMO A	165.10	157.44
UNII7	802.11ax160	143	6665	MCS0	FullBW	MIMO B	164.80	155.20

B.2.2 Maximum Output power & Maximum power spectral Density

Test limits

FCC part	RSS part	Limits
15.407 (a) (7)	RSS-248 Clause 4.5.5	<p>For client devices, except for fixed client devices as defined in this subpart, operating under the control of a standard power access point in 5.925– 6.425 GHz and 6.525–6.875 GHz bands :</p> <ul style="list-style-type: none"> ▪ the maximum power spectral density must not exceed 17 dBm e.i.r.p. in any 1- megahertz band, ▪ the maximum e.i.r.p. over the frequency band of operation must not exceed 30 dBm ▪ the device must limit its power to no more than 6 dB below its associated standard power access point's authorized transmit power.

Test procedure

The Maximum Conducted Output Power was measured using the channel integration method over the entire 99% occupied bandwidth according to section E) 2) d) (Method SA-2) of KDB 789033

The maximum power spectral density (PSD) was measured using the method according to section F) (Method SA-2) of KDB 789033

In the *measure-and-sum* approach for MIMO mode, the conducted emission level (e.g., transmit power or power in specified bandwidth) is measured at each antenna port. The measured results at the various antenna ports are then summed mathematically in linear power units to determine the total emission level from the device. When MIMO mode is running each single antenna conducted output power is reduced by 3dBi such that MIMO mode does not exceed the output of a single chain in SISO mode. $SISO\ A\ pwr = SISO\ B\ pwr = MIMO\ pwr\ (1/2\ A\ pwr + 1/2\ B\ pwr)$.

The EIRP power (dBm) is calculated by adding the declared maximum antenna gain (+5.59dBi) to the measured conducted power in accordance with KDB 662911 D01 v02r01. All transmit signals are completely uncorrelated with each other. Therefore, Directional gain = GANT = +5.59 dBi.

Per KDB 662911 D01 v02r01: MIMO Spacial diversity applies as completely uncorrelated, neither beamforming, whether fixed or adaptative, nor Cyclic Delay Diversity (CDD) technique are used. For further details, refer to 'MIMO Theory of Operation' document.

The conducted setup shown in section *Test & System Description* was used to measure the maximum conducted output power and power spectral density. The antenna terminal of the EUT is connected to the spectrum analyser through an attenuator, and the spectrum analyzer reading is compensated to include the RF path loss.

See Annex C.1.2 for the screenshot results.

Results tables

Duty cycle

Mode	Rate	Antenna	Duty Cycle [%]
802.11ax20	MCS0	SISO A	98.70
		SISO B	98.70
		MIMO A	98.70
		MIMO B	98.70
802.11ax40	MCS0	SISO A	98.70
		SISO B	98.70
		MIMO A	98.70
		MIMO B	98.70
802.11ax80	MCS0	SISO A	98.70
		SISO B	98.70
		MIMO A	98.70
		MIMO B	98.70
802.11ax160	MCS0	SISO A	98.70
		SISO B	98.70
		MIMO A	98.70
		MIMO B	98.70

Maximum output power

UNII5 (FCC & ISED)

UNII	Mode	BW [MHz]	Rate	Ch#	Freq [MHz]	RU config	Chain	Ouput Power [dBm]	Max ⁽¹⁾ Ouput Power [dBm]	Antenna Gain (dBi)	Max ⁽¹⁾ EIRP [dBm]	Max ⁽¹⁾ Output Power [mW]	Max ⁽¹⁾ . EIRP [mW]
UNII5	802.11ax	20	MCS0	1	5955	Full BW	SISO A	19.34	19.34	5.59	24.93	85.90	311.17
							SISO B	19.19	19.19		24.78	82.99	300.61
							MIMO A	18.32	18.32		23.91	67.92	246.04
							MIMO B	18.05	18.05		23.64	63.83	231.21
							Combined A+B	21.20	21.20		26.79	131.83	477.53
				45	6175		SISO A	19.04	19.04		24.63	80.17	290.40
							SISO B	19.02	19.02		24.61	79.80	289.07
							MIMO A	18.94	18.94		24.53	78.34	283.79
							MIMO B	18.90	18.90		24.49	77.62	281.19
							Combined A+B	21.93	21.93		27.52	155.96	564.94
				93	6415		SISO A	19.36	19.36		24.95	86.30	312.61
							SISO B	19.44	19.44		25.03	87.90	318.42
							MIMO A	18.35	18.35		23.94	68.39	247.74
							MIMO B	18.41	18.41		24.00	69.34	251.19
							Combined A+B	21.39	21.39		26.98	137.72	498.88
	802.11ax	40	MCS0	3	5965	Full BW	SISO A	19.47	19.47	25.06	88.51	320.63	
							SISO B	19.38	19.38	24.97	86.70	314.05	
							MIMO A	19.42	19.42	25.01	87.50	316.96	
							MIMO B	19.35	19.35	24.94	86.10	311.89	
							Combined A+B	22.40	22.40	27.99	173.78	629.51	
				43	6165		SISO A	19.39	19.39	24.98	86.90	314.77	
							SISO B	19.31	19.31	24.90	85.31	309.03	
							MIMO A	19.28	19.28	24.87	84.72	306.90	
							MIMO B	19.25	19.25	24.84	84.14	304.79	
							Combined A+B	22.28	22.28	27.87	169.04	612.35	
				91	6405		SISO A	19.42	19.42	25.01	87.50	316.96	
							SISO B	19.60	19.60	25.19	91.20	330.37	
							MIMO A	19.38	19.38	24.97	86.70	314.05	
							MIMO B	19.60	19.60	25.19	91.20	330.37	
							Combined A+B	22.50	22.50	28.09	177.83	644.17	
	802.11ax	80	MCS0	7	5985	Full BW	SISO A	19.41	19.41	25.00	87.30	316.23	
							SISO B	19.22	19.22	24.81	83.56	302.69	
							MIMO A	19.31	19.31	24.90	85.31	309.03	
							MIMO B	19.22	19.22	24.81	83.56	302.69	
							Combined A+B	22.28	22.28	27.87	169.04	612.35	
				39	6145		SISO A	19.20	19.20	24.79	83.18	301.30	
SISO B							19.28	19.28	24.87	84.72	306.90		
MIMO A							19.15	19.15	24.74	82.22	297.85		
MIMO B							19.28	19.28	24.87	84.72	306.90		
Combined A+B							22.23	22.23	27.82	167.11	605.34		
87				6385	SISO A		19.44	19.44	25.03	87.90	318.42		
					SISO B		19.65	19.65	25.24	92.26	334.20		
					MIMO A		19.42	19.42	25.01	87.50	316.96		
					MIMO B		19.68	19.68	25.27	92.90	336.51		
					Combined A+B		22.56	22.56	28.15	180.30	653.13		

UNII	Mode	BW [MHz]	Rate	Ch#	Freq [MHz]	RU config	Chain	Ouput Power [dBm]	Max ⁽¹⁾ Ouput Power [dBm]	Antenn a Gain (dBi)	Max ⁽¹⁾ EIRP [dBm]	Max ⁽¹⁾ Outpu t Power [mW]	Max ⁽¹⁾ . EIRP [mW]
	802.11ax	160	MCS0	15	6025	Full BW	SISO A	16.19	16.19		21.78	41.59	150.66
							SISO B	15.86	15.86		21.45	38.55	139.64
							MIMO A	17.20	17.20		22.79	52.48	190.11
							MIMO B	15.83	15.83		21.42	38.28	138.68
							Combined A+B	19.58	19.58		25.17	90.78	328.85
				79	6345		SISO A	17.30	17.30		22.89	53.70	194.54
							SISO B	16.36	16.36		21.95	43.25	156.68
							MIMO A	17.33	17.33		22.92	54.08	195.88
							MIMO B	16.34	16.34		21.93	43.05	155.96
							Combined A+B	19.87	19.87		25.46	97.05	351.56

- (1) Value compensated with the duty cycle
- (2) Max/Min value highlighted per bandwidth

UNII6 (Only ISED)

UNII	Mode	BW [MHz]	Rate	Ch#	Freq [MHz]	RU config	Chain	Ouput Power [dBm]	Max ⁽¹⁾ Ouput Power [dBm]	Antenna Gain (dBi)	Max ⁽¹⁾ EIRP [dBm]	Max ⁽¹⁾ Output Power [mW]	Max ⁽¹⁾ EIRP [mW]
UNII6	802.11ax	20	MCS0	97	6435	Full BW	SISO A	16.83	16.83	5.59	22.42	48.19	174.58
							SISO B	15.71	15.71		21.30	37.24	134.90
							MIMO A	16.92	16.92		22.51	49.20	178.24
							MIMO B	15.68	15.68		21.27	36.98	133.97
							Combined A+B	19.35	19.35		24.94	86.10	311.89
				105	6475		SISO A	16.84	16.84		22.43	48.31	174.98
							SISO B	15.58	15.58		21.17	36.14	130.92
							MIMO A	16.85	16.85		22.44	48.42	175.39
							MIMO B	15.58	15.58		21.17	36.14	130.92
							Combined A+B	19.27	19.27		24.86	84.53	306.20
				113	6515		SISO A	16.94	16.94		22.53	49.43	179.06
							SISO B	15.42	15.42		21.01	34.83	126.18
							MIMO A	16.87	16.87		22.46	48.64	176.20
							MIMO B	14.90	14.90		20.49	30.90	111.94
							Combined A+B	19.01	19.01		24.60	79.62	288.40
	802.11ax	40	MCS0	99	6445	Full BW	SISO A	13.11	13.11	18.70	20.46	74.13	
							SISO B	14.28	14.28	19.87	26.79	97.05	
							MIMO A	13.84	13.84	19.43	24.21	87.70	
							MIMO B	13.54	13.54	19.13	22.59	81.85	
							Combined A+B	16.70	16.70	22.29	46.77	169.43	
				107	6485		SISO A	13.08	13.08	18.67	20.32	73.62	
							SISO B	15.47	15.47	21.06	35.24	127.64	
							MIMO A	13.21	13.21	18.80	20.94	75.86	
							MIMO B	14.38	14.38	19.97	27.42	99.31	
							Combined A+B	16.84	16.84	22.43	48.31	174.98	
				115	6525		SISO A	14.21	14.21	19.80	26.36	95.50	
							SISO B	15.47	15.47	21.06	35.24	127.64	
							MIMO A	17.37	17.37	22.96	54.58	197.70	
							MIMO B	15.95	15.95	21.54	39.36	142.56	
							Combined A+B	19.73	19.73	25.32	93.97	340.41	
	802.11ax	80	MCS0	103	6465	Full BW	SISO A	16.74	16.74	22.33	47.21	171.00	
							SISO B	16.81	16.81	22.40	47.97	173.78	
							MIMO A	16.80	16.80	22.39	47.86	173.38	
							MIMO B	16.85	16.85	22.44	48.42	175.39	
							Combined A+B	19.84	19.84	25.43	96.38	349.14	
				119	6545		SISO A	16.75	16.75	22.34	47.32	171.40	
SISO B							16.78	16.78	22.37	47.64	172.58		
MIMO A							16.94	16.94	22.53	49.43	179.06		
MIMO B							16.83	16.83	22.42	48.19	174.58		
Combined A+B							19.90	19.90	25.49	97.72	354.00		
802.11ax	160	MCS0	111	6505	Full BW	SISO A	16.33	16.33	21.92	42.95	155.60		
						SISO B	16.19	16.19	21.78	41.59	150.66		
						MIMO A	17.48	17.48	23.07	55.98	202.77		
						MIMO B	16.01	16.01	21.60	39.90	144.54		
						Combined A+B	19.82	19.82	25.41	95.94	347.54		

Test Report N° 221108-01.TR02

- (1) Value compensated with the duty cycle
- (2) Max/Min value highlighted per bandwidth

UNII7 (FCC & ISD)

UNII	Mode	BW [MHz]	Rate	Ch#	Freq [MHz]	RU config	Chain	Ouput Power [dBm]	Max ⁽¹⁾ Ouput Power [dBm]	Antenn a Gain (dBi)	Max ⁽¹⁾ EIRP [dBm]	Max ⁽¹⁾ Output Power [mW]	Max ⁽¹⁾ EIRP [mW]
UNII7	802.11ax	20	MCS0	117	6535	Full BW	SISO A	19.11	19.11	5.59	24.70	81.47	295.12
							SISO B	19.34	19.34		24.93	85.90	311.17
							MIMO A	19.08	19.08		24.67	80.91	293.09
							MIMO B	18.30	18.30		23.89	67.61	244.91
				Combined A+B	21.72		21.72	27.31	148.59		538.27		
				SISO A	19.32		19.32	24.91	85.51		309.74		
				SISO B	19.32		19.32	24.91	85.51		309.74		
				MIMO A	18.38		18.38	23.97	68.87		249.46		
				MIMO B	18.22		18.22	23.81	66.37		240.44		
				Combined A+B	21.31		21.31	26.90	135.21		489.78		
				SISO A	19.58		19.58	25.17	90.78		328.85		
				SISO B	19.71		19.71	25.30	93.54		338.84		
		MIMO A	18.66	18.66	24.25	73.45	266.07						
		MIMO B	18.65	18.65	24.24	73.28	265.46						
		Combined A+B	21.67	21.67	27.26	146.89	532.11						
		SISO A	19.29	19.29	24.88	84.92	307.61						
		SISO B	19.44	19.44	25.03	87.90	318.42						
		MIMO A	19.38	19.38	24.97	86.70	314.05						
		MIMO B	19.31	19.31	24.90	85.31	309.03						
		Combined A+B	22.36	22.36	27.95	172.19	623.73						
		SISO A	19.54	19.54	25.13	89.95	325.84						
		SISO B	19.50	19.50	25.09	89.13	322.85						
		MIMO A	19.64	19.64	25.23	92.04	333.43						
		MIMO B	19.40	19.40	24.99	87.10	315.50						
		Combined A+B	22.53	22.53	28.12	179.06	648.63						
		SISO A	19.63	19.63	25.22	91.83	332.66						
		SISO B	19.94	19.94	25.53	98.63	357.27						
		MIMO A	19.77	19.77	25.36	94.84	343.56						
		MIMO B	19.79	19.79	25.38	95.28	345.14						
		Combined A+B	22.79	22.79	28.38	190.11	688.65						
		SISO A	19.48	19.48	25.07	88.72	321.37						
		SISO B	19.39	19.39	24.98	86.90	314.77						
		MIMO A	19.32	19.32	24.91	85.51	309.74						
		MIMO B	19.37	19.37	24.96	86.50	313.33						
		Combined A+B	22.36	22.36	27.95	172.19	623.73						
		SISO A	19.30	19.30	24.89	85.11	308.32						
		SISO B	19.47	19.47	25.06	88.51	320.63						
		MIMO A	19.48	19.48	25.07	88.72	321.37						
		MIMO B	19.41	19.41	25.00	87.30	316.23						
		Combined A+B	22.46	22.46	28.05	176.20	638.26						
		SISO A	19.60	19.60	25.19	91.20	330.37						
		SISO B	19.53	19.53	25.12	89.74	325.09						
		MIMO A	19.63	19.63	25.22	91.83	332.66						
		MIMO B	19.46	19.46	25.05	88.31	319.89						
		Combined A+B	22.56	22.56	28.15	180.30	653.13						

UNI	Mode	BW [MHz]	Rate	Ch#	Freq [MHz]	RU config	Chain	Ouput Power [dBm]	Max ⁽¹⁾ Ouput Power [dBm]	Antenna Gain (dBi)	Max ⁽¹⁾ EIRP [dBm]	Max ⁽¹⁾ Output Power [mW]	Max ⁽¹⁾ EIRP [mW]
		160	MCS0	143	6665	Full BW	SISO A	16.09	16.09		21.68	40.64	147.23
	SISO B						16.26	16.26		21.85	42.27	153.11	
	MIMO A						16.11	16.11		21.70	40.83	147.91	
	MIMO B						16.17	16.17		21.76	41.40	149.97	
	Combined A+B						19.15	19.15		24.74	82.23	297.88	

(1) Value compensated with the duty cycle
(2) Max/Min value highlighted per bandwidth

Maximum Power Spectral Density (PSD)**UNII5 (FCC & ISED)**

UNII	Mode_BW	Rate	Channel	Freq. [MHz]	RU config.	Antenna	PSD [dBm/MHz]	Max ⁽¹⁾ PSD [dBm/MHz]	Antenna Gain (dBi)	Max ⁽¹⁾ PSD EIRP [dBm/MHz]
UNII5	802.11ax20	MCS0	1	5955	FullBW	SISO A	8.83	8.83	5.59	14.42
UNII5	802.11ax20	MCS0	1	5955	FullBW	SISO B	8.35	8.35		13.94
UNII5	802.11ax20	MCS0	1	5955	FullBW	MIMO A	7.46	7.46		13.05
UNII5	802.11ax20	MCS0	1	5955	FullBW	MIMO B	7.36	7.36		12.95
UNII5	802.11ax20	MCS0	1	5955	FullBW	Combined A+B	10.42	10.42		16.01
UNII5	802.11ax20	MCS0	45	6175	FullBW	SISO A	8.23	8.23		13.82
UNII5	802.11ax20	MCS0	45	6175	FullBW	SISO B	8.14	8.14		13.73
UNII5	802.11ax20	MCS0	45	6175	FullBW	MIMO A	8.12	8.12		13.71
UNII5	802.11ax20	MCS0	45	6175	FullBW	MIMO B	8.10	8.10		13.69
UNII5	802.11ax20	MCS0	45	6175	FullBW	Combined A+B	11.12	11.12		16.71
UNII5	802.11ax20	MCS0	93	6415	FullBW	SISO A	8.45	8.45		14.04
UNII5	802.11ax20	MCS0	93	6415	FullBW	SISO B	8.68	8.68		14.27
UNII5	802.11ax20	MCS0	93	6415	FullBW	MIMO A	7.59	7.59		13.18
UNII5	802.11ax20	MCS0	93	6415	FullBW	MIMO B	7.56	7.56		13.15
UNII5	802.11ax20	MCS0	93	6415	FullBW	Combined A+B	10.59	10.59		16.18
UNII5	802.11ax40	MCS0	3	5965	FullBW	SISO A	5.25	5.25		10.84
UNII5	802.11ax40	MCS0	3	5965	FullBW	SISO B	5.18	5.18		10.77
UNII5	802.11ax40	MCS0	3	5965	FullBW	MIMO A	5.17	5.17		10.76
UNII5	802.11ax40	MCS0	3	5965	FullBW	MIMO B	5.39	5.39		10.98
UNII5	802.11ax40	MCS0	3	5965	FullBW	Combined A+B	8.29	8.29		13.88
UNII5	802.11ax40	MCS0	43	6165	FullBW	SISO A	5.19	5.19		10.78
UNII5	802.11ax40	MCS0	43	6165	FullBW	SISO B	5.08	5.08		10.67
UNII5	802.11ax40	MCS0	43	6165	FullBW	MIMO A	5.17	5.17		10.76
UNII5	802.11ax40	MCS0	43	6165	FullBW	MIMO B	5.11	5.11		10.70
UNII5	802.11ax40	MCS0	43	6165	FullBW	Combined A+B	8.15	8.15		13.74
UNII5	802.11ax40	MCS0	91	6405	FullBW	SISO A	5.44	5.44		11.03
UNII5	802.11ax40	MCS0	91	6405	FullBW	SISO B	5.41	5.41		11.00
UNII5	802.11ax40	MCS0	91	6405	FullBW	MIMO A	5.33	5.33		10.92
UNII5	802.11ax40	MCS0	91	6405	FullBW	MIMO B	5.53	5.53		11.12
UNII5	802.11ax40	MCS0	91	6405	FullBW	Combined A+B	8.44	8.44		14.03
UNII5	802.11ax80	MCS0	7	5985	FullBW	SISO A	2.31	2.31		7.90
UNII5	802.11ax80	MCS0	7	5985	FullBW	SISO B	2.10	2.10		7.69
UNII5	802.11ax80	MCS0	7	5985	FullBW	MIMO A	2.13	2.13	7.72	
UNII5	802.11ax80	MCS0	7	5985	FullBW	MIMO B	2.10	2.10	7.69	
UNII5	802.11ax80	MCS0	7	5985	FullBW	Combined A+B	5.13	5.13	10.72	
UNII5	802.11ax80	MCS0	39	6145	FullBW	SISO A	2.17	2.17	7.76	
UNII5	802.11ax80	MCS0	39	6145	FullBW	SISO B	2.16	2.16	7.75	
UNII5	802.11ax80	MCS0	39	6145	FullBW	MIMO A	2.08	2.08	7.67	
UNII5	802.11ax80	MCS0	39	6145	FullBW	MIMO B	2.17	2.17	7.76	
UNII5	802.11ax80	MCS0	39	6145	FullBW	Combined A+B	5.14	5.14	10.73	
UNII5	802.11ax80	MCS0	87	6385	FullBW	SISO A	2.23	2.23	7.82	
UNII5	802.11ax80	MCS0	87	6385	FullBW	SISO B	2.58	2.58	8.17	
UNII5	802.11ax80	MCS0	87	6385	FullBW	MIMO A	2.26	2.26	7.85	
UNII5	802.11ax80	MCS0	87	6385	FullBW	MIMO B	2.43	2.43	8.02	
UNII5	802.11ax80	MCS0	87	6385	FullBW	Combined A+B	5.36	5.36	10.95	

UNII	Mode_BW	Rate	Channel	Freq. [MHz]	RU config.	Antenna	PSD [dBm/MHz]	Max ⁽¹⁾ PSD [dBm/MHz]	Antenna Gain (dBi)	Max ⁽¹⁾ PSD EIRP [dBm/MHz]
UNII5	802.11ax160	MCS0	15	6025	FullBW	SISO A	-3.51	-3.51		2.08
UNII5	802.11ax160	MCS0	15	6025	FullBW	SISO B	-3.99	-3.99		1.60
UNII5	802.11ax160	MCS0	15	6025	FullBW	MIMO A	-2.47	-2.47		3.12
UNII5	802.11ax160	MCS0	15	6025	FullBW	MIMO B	-3.78	-3.78		1.81
UNII5	802.11ax160	MCS0	15	6025	FullBW	Combined A+B	-0.07	-0.07		5.52
UNII5	802.11ax160	MCS0	79	6345	FullBW	SISO A	-2.40	-2.40		3.19
UNII5	802.11ax160	MCS0	79	6345	FullBW	SISO B	-3.24	-3.24		2.35
UNII5	802.11ax160	MCS0	79	6345	FullBW	MIMO A	-2.51	-2.51		3.08
UNII5	802.11ax160	MCS0	79	6345	FullBW	MIMO B	-3.36	-3.36		2.23
UNII5	802.11ax160	MCS0	79	6345	FullBW	Combined A+B	0.10	0.10		5.69

⁽¹⁾ Value compensated with the duty cycle

UNII6 (Only ISED)

UNII	Mode_BW	Rate	Channel	Freq. [MHz]	RU config.	Antenna	PSD [dBm/MHz]	Max ⁽¹⁾ PSD [dBm/MHz]	Antenna Gain (dBi)	Max ⁽¹⁾ PSD EIRP [dBm/MHz]
UNII6	802.11ax20	MCS0	97	6435	FullBW	SISO A	5.08	5.08		10.67
UNII6	802.11ax20	MCS0	97	6435	FullBW	SISO B	3.90	3.90		9.49
UNII6	802.11ax20	MCS0	97	6435	FullBW	MIMO A	5.18	5.18		10.77
UNII6	802.11ax20	MCS0	97	6435	FullBW	MIMO B	3.93	3.93		9.52
UNII6	802.11ax20	MCS0	97	6435	FullBW	Combined A+B	7.61	7.61		13.20
UNII6	802.11ax20	MCS0	105	6475	FullBW	SISO A	5.00	5.00		10.59
UNII6	802.11ax20	MCS0	105	6475	FullBW	SISO B	3.93	3.93		9.52
UNII6	802.11ax20	MCS0	105	6475	FullBW	MIMO A	4.95	4.95		10.54
UNII6	802.11ax20	MCS0	105	6475	FullBW	MIMO B	3.78	3.78		9.37
UNII6	802.11ax20	MCS0	105	6475	FullBW	Combined A+B	7.41	7.41		13.00
UNII6	802.11ax20	MCS0	113	6515	FullBW	SISO A	5.03	5.03		10.62
UNII6	802.11ax20	MCS0	113	6515	FullBW	SISO B	3.60	3.60		9.19
UNII6	802.11ax20	MCS0	113	6515	FullBW	MIMO A	5.08	5.08		10.67
UNII6	802.11ax20	MCS0	113	6515	FullBW	MIMO B	3.12	3.12		8.71
UNII6	802.11ax20	MCS0	113	6515	FullBW	Combined A+B	7.22	7.22		12.81
UNII6	802.11ax40	MCS0	99	6445	FullBW	SISO A	-1.62	-1.62	5.59	3.97
UNII6	802.11ax40	MCS0	99	6445	FullBW	SISO B	-0.52	-0.52		5.07
UNII6	802.11ax40	MCS0	99	6445	FullBW	MIMO A	-1.00	-1.00		4.59
UNII6	802.11ax40	MCS0	99	6445	FullBW	MIMO B	-1.19	-1.19		4.40
UNII6	802.11ax40	MCS0	99	6445	FullBW	Combined A+B	1.92	1.92		7.51
UNII6	802.11ax40	MCS0	107	6485	FullBW	SISO A	-1.81	-1.81		3.78
UNII6	802.11ax40	MCS0	107	6485	FullBW	SISO B	0.76	0.76		6.35
UNII6	802.11ax40	MCS0	107	6485	FullBW	MIMO A	-1.53	-1.53		4.06
UNII6	802.11ax40	MCS0	107	6485	FullBW	MIMO B	-0.17	-0.17		5.42
UNII6	802.11ax40	MCS0	107	6485	FullBW	Combined A+B	2.21	2.21		7.80
UNII6	802.11ax40	MCS0	115	6525	FullBW	SISO A	-0.78	-0.78	4.81	
UNII6	802.11ax40	MCS0	115	6525	FullBW	SISO B	0.67	0.67	6.26	
UNII6	802.11ax40	MCS0	115	6525	FullBW	MIMO A	2.44	2.44	8.03	
UNII6	802.11ax40	MCS0	115	6525	FullBW	MIMO B	1.08	1.08	6.67	
UNII6	802.11ax40	MCS0	115	6525	FullBW	Combined A+B	4.82	4.82	10.41	
UNII6	802.11ax80	MCS0	103	6465	FullBW	SISO A	-0.26	-0.26		5.33
UNII6	802.11ax80	MCS0	103	6465	FullBW	SISO B	-0.36	-0.36		5.23
UNII6	802.11ax80	MCS0	103	6465	FullBW	MIMO A	-0.40	-0.40		5.19

UNII6	802.11ax80	MCS0	103	6465	FullBW	MIMO B	-0.18	-0.18		5.41
UNII6	802.11ax80	MCS0	103	6465	FullBW	Combined A+B	2.72	2.72		8.31
UNII6	802.11ax80	MCS0	119	6545	FullBW	SISO A	-0.37	-0.37		5.22
UNII6	802.11ax80	MCS0	119	6545	FullBW	SISO B	-0.31	-0.31		5.28
UNII6	802.11ax80	MCS0	119	6545	FullBW	MIMO A	-0.16	-0.16		5.43
UNII6	802.11ax80	MCS0	119	6545	FullBW	MIMO B	-0.34	-0.34		5.25
UNII6	802.11ax80	MCS0	119	6545	FullBW	Combined A+B	2.76	2.76		8.35
UNII6	802.11ax160	MCS0	111	6505	FullBW	SISO A	-3.43	-3.43		2.16
UNII6	802.11ax160	MCS0	111	6505	FullBW	SISO B	-3.63	-3.63		1.96
UNII6	802.11ax160	MCS0	111	6505	FullBW	MIMO A	-2.31	-2.31		3.28
UNII6	802.11ax160	MCS0	111	6505	FullBW	MIMO B	-3.65	-3.65		1.94
UNII6	802.11ax160	MCS0	111	6505	FullBW	Combined A+B	0.08	0.08		5.67

(1) Value compensated with the duty cycle

UNII7 (FCC & ISED)

UNII	Mode_BW	Rate	Channel	Freq. [MHz]	RU config.	Antenna	PSD [dBm/MHz]	Max ⁽¹⁾ PSD [dBm/MHz]	Antenna Gain (dBi)	Max ⁽¹⁾ PSD EIRP [dBm/MHz]
UNII7	802.11ax20	MCS0	117	6535	FullBW	SISO A	8.29	8.29		13.88
UNII7	802.11ax20	MCS0	117	6535	FullBW	SISO B	8.57	8.57		14.16
UNII7	802.11ax20	MCS0	117	6535	FullBW	MIMO A	8.30	8.30		13.89
UNII7	802.11ax20	MCS0	117	6535	FullBW	MIMO B	7.55	7.55		13.14
UNII7	802.11ax20	MCS0	117	6535	FullBW	Combined A+B	10.95	10.95		16.54
UNII7	802.11ax20	MCS0	149	6695	FullBW	SISO A	8.45	8.45		14.04
UNII7	802.11ax20	MCS0	149	6695	FullBW	SISO B	8.46	8.46		14.05
UNII7	802.11ax20	MCS0	149	6695	FullBW	MIMO A	7.64	7.64		13.23
UNII7	802.11ax20	MCS0	149	6695	FullBW	MIMO B	7.53	7.53		13.12
UNII7	802.11ax20	MCS0	149	6695	FullBW	Combined A+B	10.60	10.60		16.19
UNII7	802.11ax20	MCS0	181	6855	FullBW	SISO A	8.91	8.91		14.50
UNII7	802.11ax20	MCS0	181	6855	FullBW	SISO B	8.93	8.93		14.52
UNII7	802.11ax20	MCS0	181	6855	FullBW	MIMO A	7.94	7.94		13.53
UNII7	802.11ax20	MCS0	181	6855	FullBW	MIMO B	8.01	8.01		13.60
UNII7	802.11ax20	MCS0	181	6855	FullBW	Combined A+B	10.99	10.99		16.58
UNII7	802.11ax40	MCS0	123	6565	FullBW	SISO A	5.10	5.10		10.69
UNII7	802.11ax40	MCS0	123	6565	FullBW	SISO B	5.26	5.26	5.59	10.85
UNII7	802.11ax40	MCS0	123	6565	FullBW	MIMO A	5.24	5.24		10.83
UNII7	802.11ax40	MCS0	123	6565	FullBW	MIMO B	5.14	5.14		10.73
UNII7	802.11ax40	MCS0	123	6565	FullBW	Combined A+B	8.20	8.20		13.79
UNII7	802.11ax40	MCS0	147	6685	FullBW	SISO A	5.46	5.46		11.05
UNII7	802.11ax40	MCS0	147	6685	FullBW	SISO B	5.23	5.23		10.82
UNII7	802.11ax40	MCS0	147	6685	FullBW	MIMO A	5.40	5.40		10.99
UNII7	802.11ax40	MCS0	147	6685	FullBW	MIMO B	5.48	5.48		11.07
UNII7	802.11ax40	MCS0	147	6685	FullBW	Combined A+B	8.45	8.45		14.04
UNII7	802.11ax40	MCS0	179	6845	FullBW	SISO A	5.58	5.58		11.17
UNII7	802.11ax40	MCS0	179	6845	FullBW	SISO B	5.83	5.83		11.42
UNII7	802.11ax40	MCS0	179	6845	FullBW	MIMO A	5.81	5.81		11.40
UNII7	802.11ax40	MCS0	179	6845	FullBW	MIMO B	5.83	5.83		11.42
UNII7	802.11ax40	MCS0	179	6845	FullBW	Combined A+B	8.83	8.83		14.42
UNII7	802.11ax80	MCS0	135	6625	FullBW	SISO A	2.28	2.28		7.87
UNII7	802.11ax80	MCS0	135	6625	FullBW	SISO B	2.22	2.22		7.81
UNII7	802.11ax80	MCS0	135	6625	FullBW	MIMO A	2.21	2.21		7.80

UNII	Mode_BW	Rate	Channel	Freq. [MHz]	RU config.	Antenna	PSD [dBm/MHz]	Max ⁽¹⁾ PSD [dBm/MHz]	Antenna Gain (dBi)	Max ⁽¹⁾ PSD EIRP [dBm/MHz]
UNII7	802.11ax80	MCS0	135	6625	FullBW	MIMO B	2.20	2.20		7.79
UNII7	802.11ax80	MCS0	135	6625	FullBW	Combined A+B	5.22	5.22		10.81
UNII7	802.11ax80	MCS0	151	6705	FullBW	SISO A	2.19	2.19		7.78
UNII7	802.11ax80	MCS0	151	6705	FullBW	SISO B	2.32	2.32		7.91
UNII7	802.11ax80	MCS0	151	6705	FullBW	MIMO A	2.45	2.45		8.04
UNII7	802.11ax80	MCS0	151	6705	FullBW	MIMO B	2.27	2.27		7.86
UNII7	802.11ax80	MCS0	151	6705	FullBW	Combined A+B	5.37	5.37		10.96
UNII7	802.11ax80	MCS0	167	6785	FullBW	SISO A	2.36	2.36		7.95
UNII7	802.11ax80	MCS0	167	6785	FullBW	SISO B	2.34	2.34		7.93
UNII7	802.11ax80	MCS0	167	6785	FullBW	MIMO A	2.60	2.60		8.19
UNII7	802.11ax80	MCS0	167	6785	FullBW	MIMO B	2.49	2.49		8.08
UNII7	802.11ax80	MCS0	167	6785	FullBW	Combined A+B	5.56	5.56		11.15
UNII7	802.11ax160	MCS0	143	6665	FullBW	SISO A	-3.68	-3.68		1.91
UNII7	802.11ax160	MCS0	143	6665	FullBW	SISO B	-3.60	-3.60		1.99
UNII7	802.11ax160	MCS0	143	6665	FullBW	MIMO A	-3.38	-3.38		2.21
UNII7	802.11ax160	MCS0	143	6665	FullBW	MIMO B	-3.45	-3.45		2.14
UNII7	802.11ax160	MCS0	143	6665	FullBW	Combined A+B	-0.40	-0.40		5.19

⁽¹⁾ Value compensated with the duty cycle

B.2.3 Emissions mask

Test limits

FCC part	RSS part	Limits
15.407 (b) (7)	RSS-248 Clause 4.6.2b	<ul style="list-style-type: none"> ▪ For transmitters operating within the 5.925–7.125 GHz bands: Power spectral density must be suppressed: <ul style="list-style-type: none"> ○ by 20 dB at 1 MHz outside of channel edge, ○ by 28 dB at one channel bandwidth from the channel center, and ○ by 40 dB at one- and one-half times the channel bandwidth away from channel center. ▪ At frequencies between one megahertz outside an unlicensed device's channel edge and one channel bandwidth from the center of the channel, the limits must be linearly interpolated between 20 dB and 28 dB suppression, and ▪ at frequencies between one and one- and onehalf times an unlicensed device's channel bandwidth, the limits must be linearly interpolated between 28 dB and 40 dB suppression. ▪ Emissions removed from the channel center by more than one- and one-half times the channel bandwidth must be suppressed by at least 40 dB.

Test procedure

The conducted setup shown in section *Test & System Description* was used to measure the unwanted mask emissions. The antenna terminal of the EUT is connected to the spectrum analyzer through an attenuator, and the spectrum analyzer reading is compensated to include the RF path loss and the declared antenna gain.

The nominal bandwidth was used to construct the mask according to KDB 987594 D02.

See Section C.1.3 for the screenshot results.

B.2.4 Frequency stability

Test limits

FCC part	RSS part	Limits
15.407 (g)	RSS-Gen issue 5 - A1- clause 6.11	The frequency stability shall be sufficient to ensure that the occupied bandwidth of the device stays within the 5925-7125MHz frequency band when the stability is tested at the temperature and supply voltage variation

Test procedure

The conducted setups shown in section *Test & System Description* were used to verify that the occupied bandwidth 99% of the device stays within the 5925-7125MHz frequency band.

For the test results refer to the report: 211201-01.TR08

B.2.5 Contention-based protocol

Test limits

Indoor access points, subordinate devices and client devices operating in the 5.925-7.125 GHz band are required to use technologies that include a contention-based protocol to avoid co-channel interference with incumbent devices sharing the band. To ensure incumbent co-channel operations are detected in a technology-agnostic manner, unlicensed devices are required to detect co-channel radio frequency energy (energy detect) and avoid simultaneous transmission.

Unlicensed indoor low-power devices must detect co-channel radio frequency power that is at least -62 dBm or lower. Upon detection of energy in the band, unlicensed low power indoor devices must vacate the channel and stay off the channel as long as detected radio frequency power is equal to or greater than the threshold (-62 dBm).

Test procedure

The contention-based protocol setup shown in section *Test & System Description* was used to measure the contention-based protocol. The EUT ceased transmission when the AWGN source signal level described in table result below is set to transmit.

Incumbent signal is emulated by using a 10MHz bandwidth AWGN source generated by the vector signal generator. The EUT is transmitting at the maximum possible payload and the spectrum analyzer monitors the transmissions in response to the AWGN signal. Insertion loss of the test setup were considered on the spectrum analyzer reading.

For the test results refer to the report 200611-01.TR38

B.2.6 Undesirable emission limits : Conducted

Test limits

FCC part	RSS Part	Limits
15.407 (b)(6)	RSS-248 Clause 4.6.2a	For transmitters operating within the 5.925-7.125 GHz band: Any emissions outside of the 5.925-7.125 GHz band must not exceed an e.i.r.p. of -27 dBm/MHz.
15.35 (b)	-	Unless otherwise specified, on any frequency or frequencies above 1000 MHz, the radiated emission limits are based on the use of measurement instrumentation employing an average detector function. Unless otherwise specified, measurements above 1000 MHz shall be performed using a minimum resolution bandwidth of 1 MHz. When average radiated emission measurements are specified in this part, including average emission measurements below 1000 MHz, there also is a limit on the peak level of the radio frequency emissions. Unless otherwise specified, e.g., see §§ 15.250, 15.252, 15.253(d), 15.255, 15.256, and 15.509 through 15.519, the limit on peak radio frequency emissions is 20 dB above the maximum permitted average emission limit applicable to the equipment under test. This peak limit applies to the total peak emission level radiated by the device, e.g., the total peak power level

Test procedure

The conducted setup shown in section *Test & System Description* was used to measure undesirable emissions on the out of band domain. The antenna terminal of the EUT is connected to the spectrum analyzer through an attenuator, and the spectrum analyzer reading is compensated to include the RF path loss and the declared antenna gain.

For the lower and upper side of the out of band, the integration method was used as defined in the out of band measurements section II.G.3.d of KDB 789033. Tests were performed using both RMS and peak detectors.

For out of band emission measurements in MIMO mode the emission level of individual output is adjusted by $10 \log(N_{\text{ant}}) = 3\text{dB}$ for $N_{\text{ant}} = 2$ which is equivalent to compare the individual output emission level to the limit minus 3dB. The same approach is applied for peak and RMS detectors.

See Section C.1.4. for the screenshot results.

B.2.7 Dual Client Test, Demonstration of Proper Power Adjustment based on Associated AP

Test limits

A client device may connect to a Standard Power AP with a maximum power level of 30 dBm EIRP. A client may also connect to a Low Power indoor AP, but the power level is limited to a maximum of 24 dBm EIRP. If a client has the flexibility to connect to both APs, verification is needed to show that it can distinguish between the two configurations, and then control the power levels accordingly.

Test procedure

The dual client test setup shown in section **Test & System Description**.

Client and APs are prepared so they associate and start sending data (stream data) to each other. Client is configured to transmit at its highest power level.

Initially, attenuation on Atten 1 is set high, so the Client will only associate with the Std Power AP. Transmission between Client and Std Power AP is verified by measuring Client Tx power using SA-3 method from C63.10. Atten 2 is gradually increased while Atten 1 is decreased. This simulates the Client moving from outdoors to indoors. At some level of attenuation, the Client should associate with the Low Power indoor AP. Transmission between Client and Low Power AP is verified by measuring Client Tx power using the same method mentioned in this paragraph. It must not be greater than 24 dBm EIRP.

Connected AP type	Channel	Freq. [MHz]	BW [MHz]	Rate	Chain	Measured Client Tx Power [dBm]	Antenna Gain [dBi]	Client Tx Power EIRP [dBm]
Standard Power	37	6135	20	MCS0	SISO B	21.99	5.59	27.58
Low Power						11.47		17.06

See Section C.1.5. for the screenshot results.

B.2.8 Proper Power Adjustment, Client Devices Connected to a Standard Power Access Point

Test limits

A client device that connects to a Standard Power AP must limit its EIRP to a minimum of 6 dB lower than its associated Standard Power access point's authorized transmit power.

Test procedure

The proper power adjustment test setup shown in section *Test & System Description*.

Client and AP are prepared so they associate and start sending data (stream data) to each other.

Client is configured to transmit at following power levels:

- Highest power level
- Mid power level
- Lowest power level, as declared by the manufacturer.

For each configuration, Client Tx power is measured using SA-2 method from C63.10 for U-NII devices.

See Section C.1.6. for the screenshot results.

AFC access point EIRP limitation [dBm]	AFC Max client EIRP limitation [dBm]	AFC Max client conducted. [dBm]	Channel	Freq. [MHz]	BW [MHz]	Rate	Chain	Duty Cycle [%]	Measured Client Tx Power [dBm]	Compensated Client Tx Power [dBm]	Antenna Gain [dBi]	Client Tx Power EIRP [dBm]
34	28	22.41	37	6135	20	MCS0	SISO B	93.5	13.45	13.74	5.59	19.33
23	17	11.41							10.97	11.26		16.85
14	8	2.41							0.93	1.22		6.81

Annex C. System Plots

C.1.1 26dB & 99% bandwidth

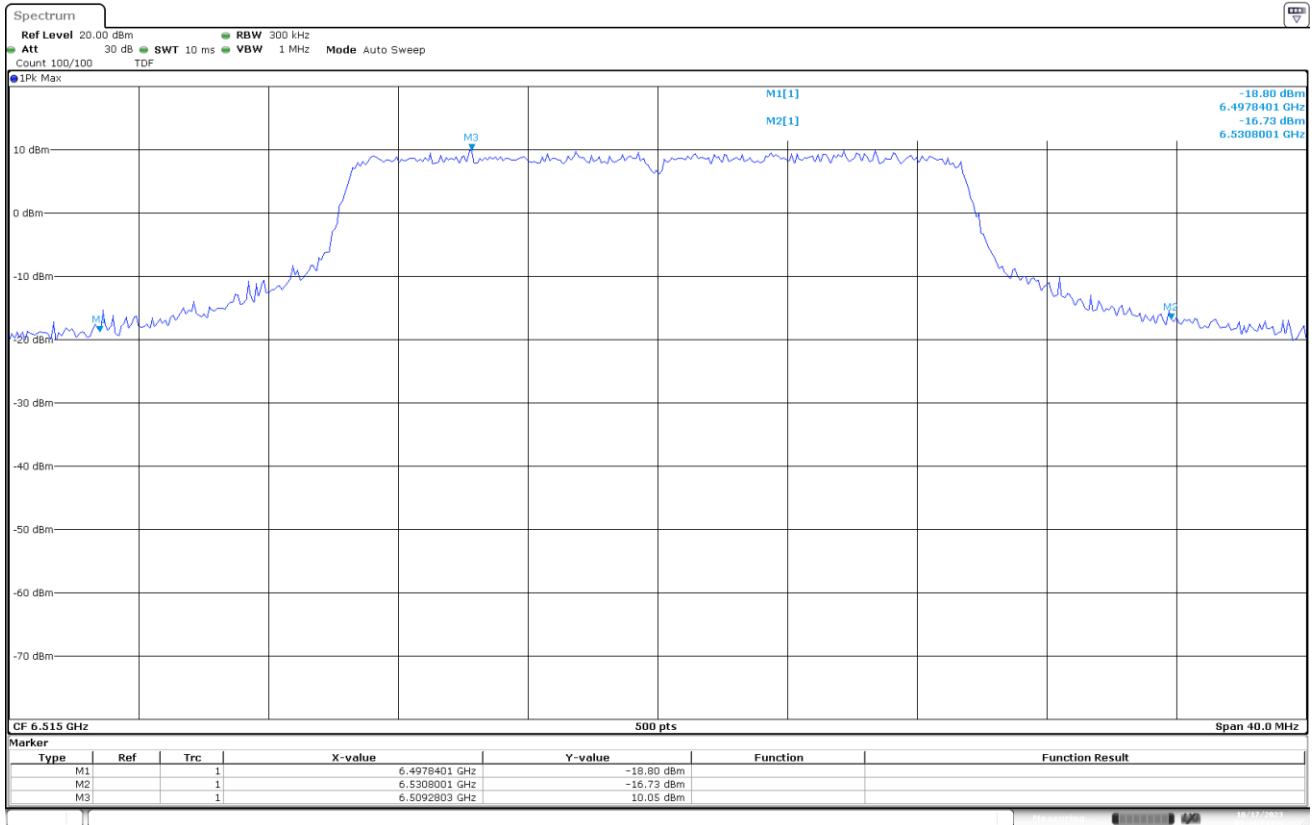

UNII-6 MIMO A 802.11ax20 CH113 6515MHz 26dB

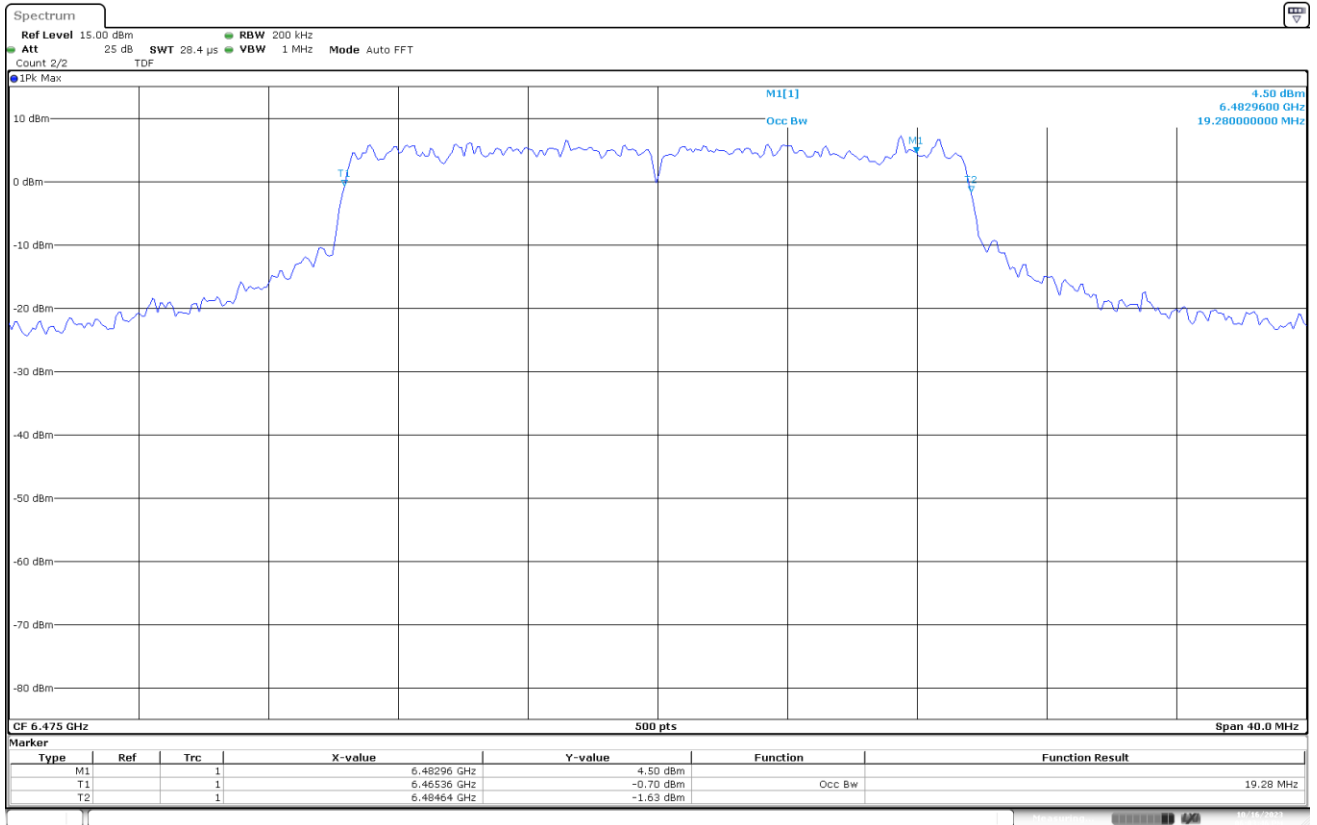

UNII-6 SISO A 802.11ax20 CH105 6475MHz 99%

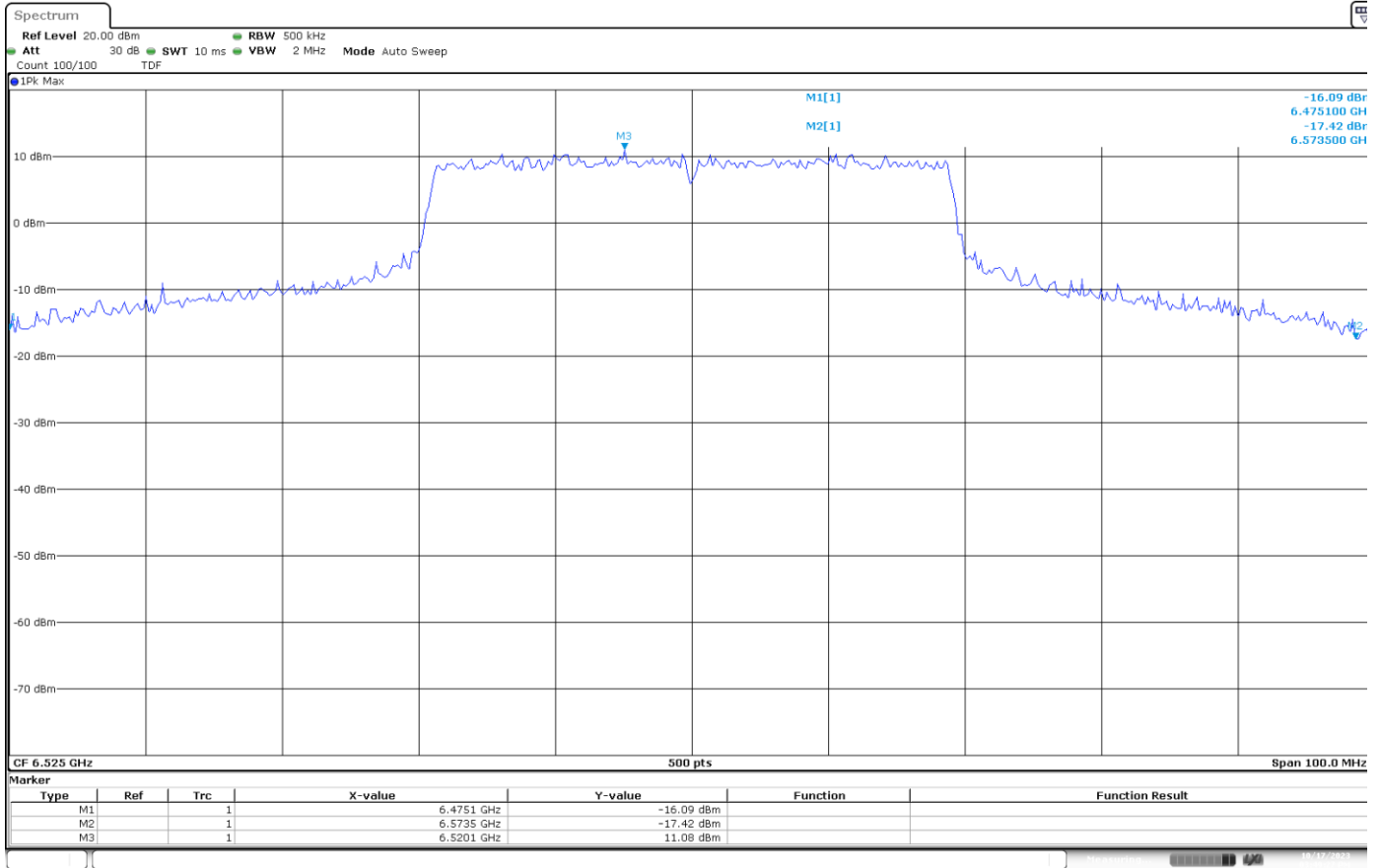

UNII-6 MIMO A 802.11ax40 CH115 6525MHz 26dB

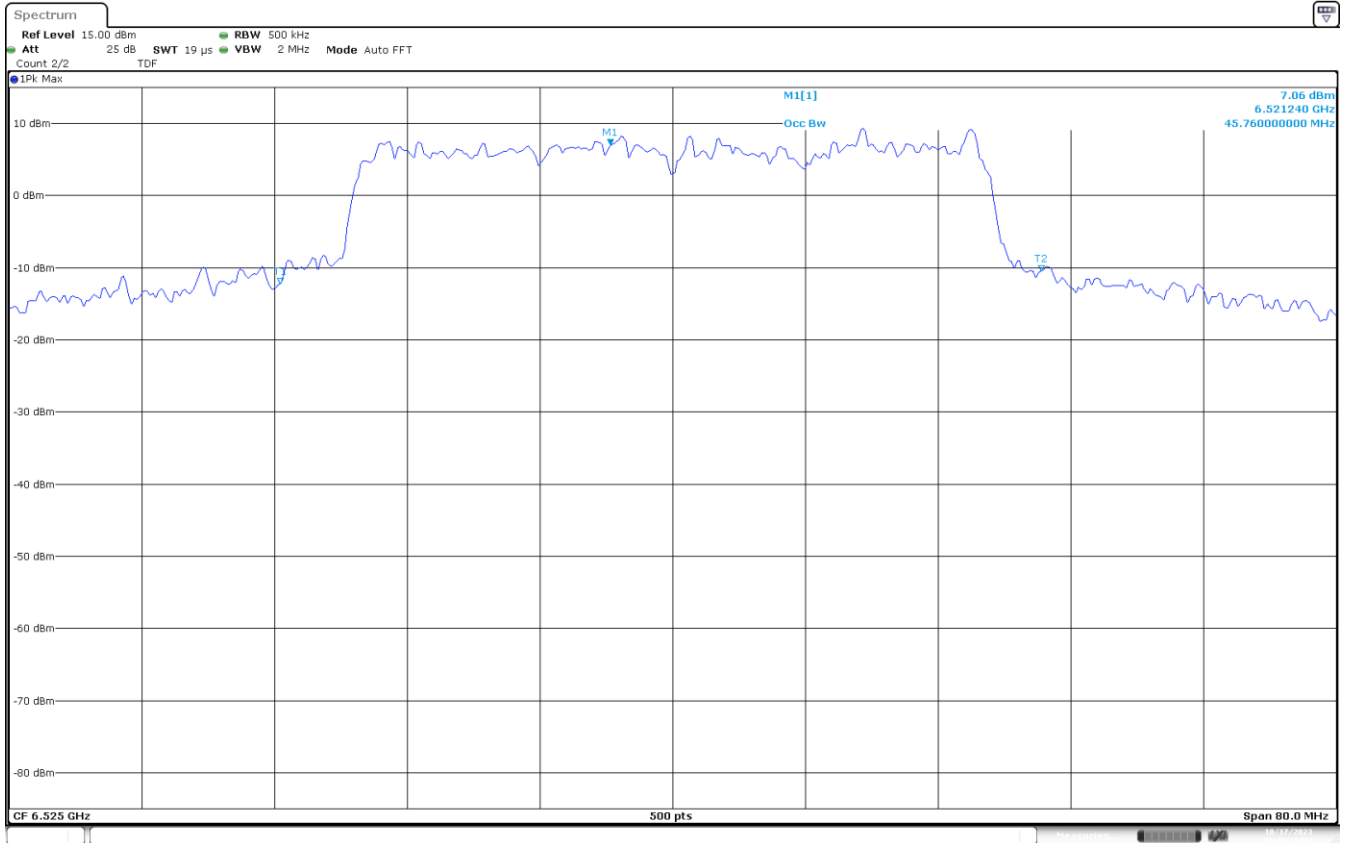

UNII-6 MIMO A 802.11ax40 CH115 6525MHz 99%

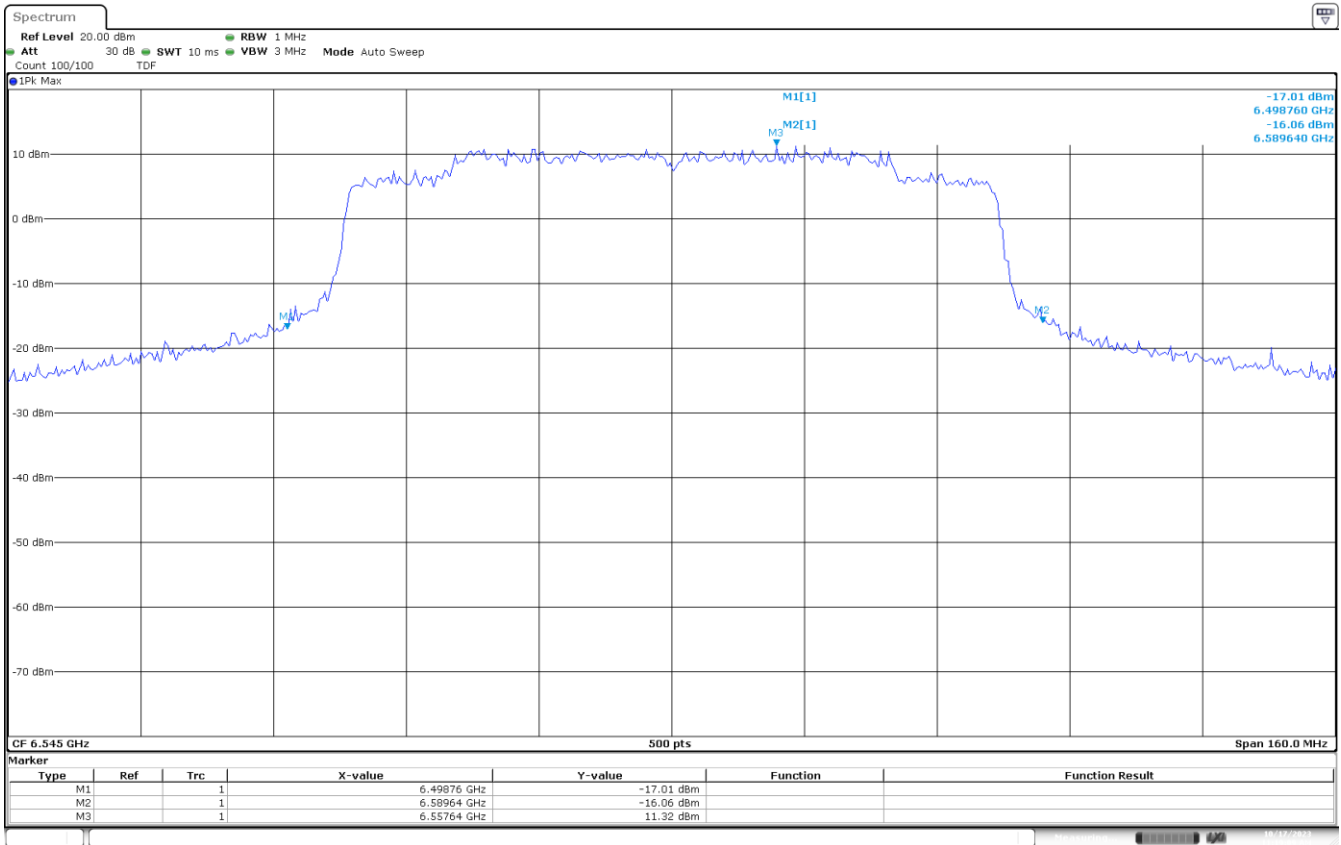

UNII-6 SISO A 802.11ax80 CH119 6545MHz 26dB

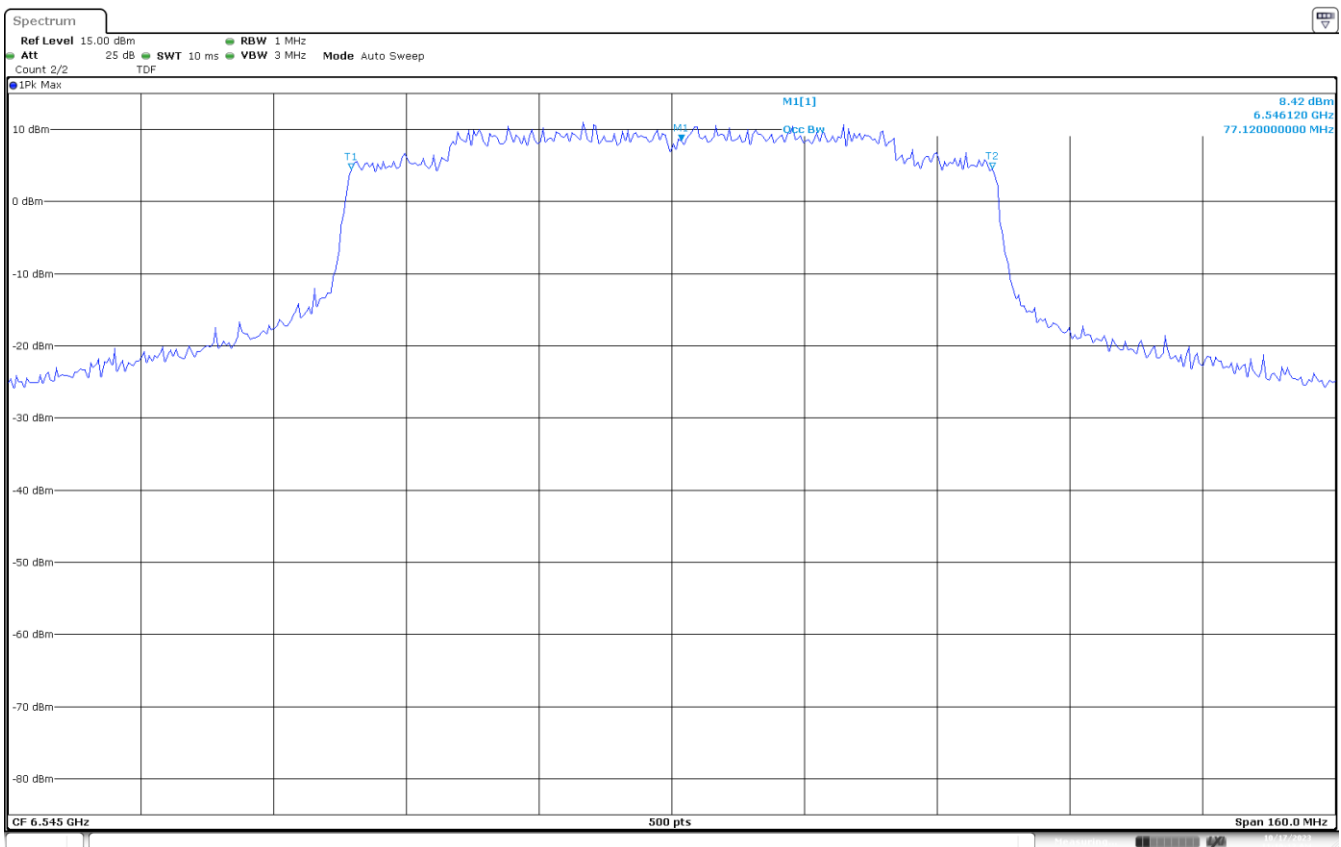

UNII-6 SISO A 802.11ax80 CH119 6545MHz 99%

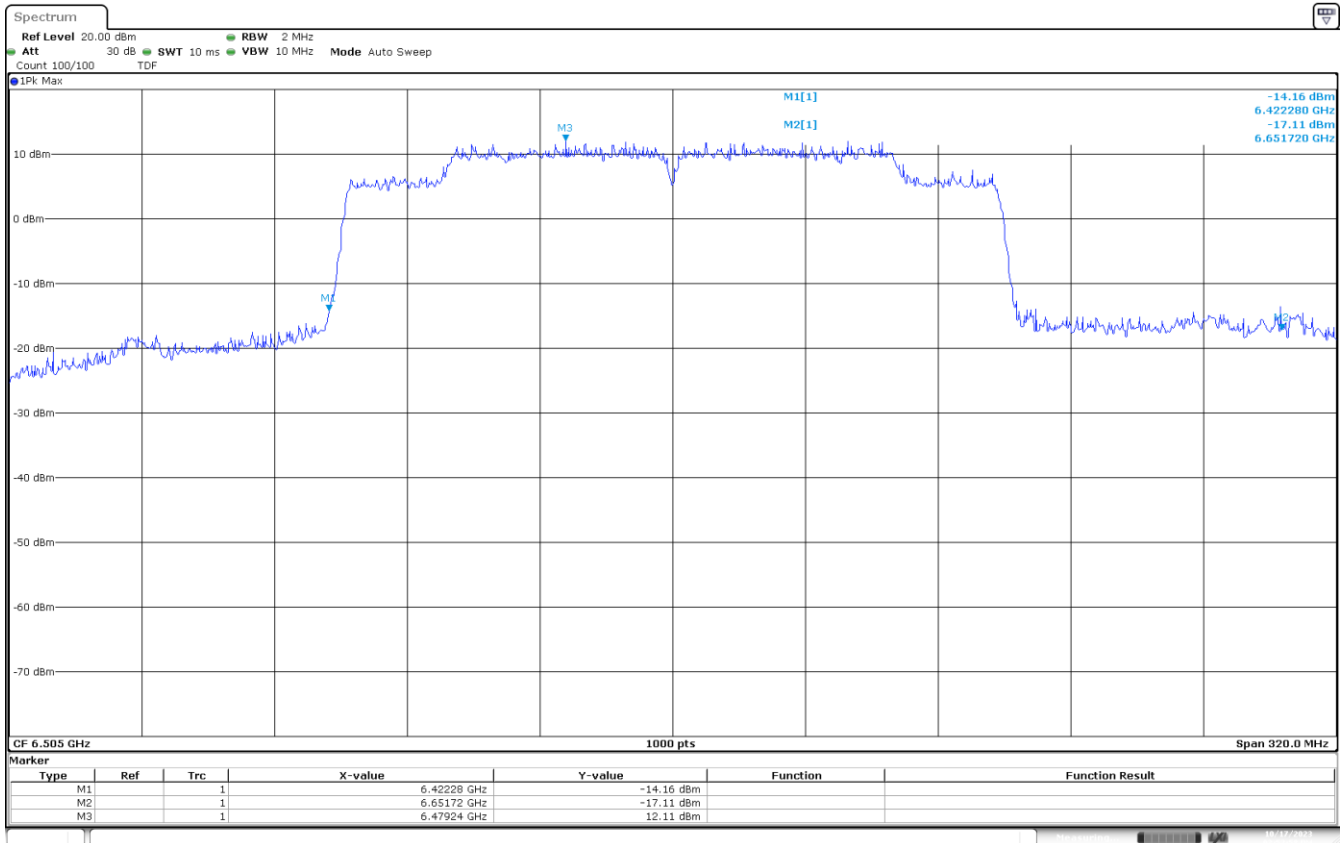

UNII-6 MIMO A 802.11ax160 CH111 6505MHz 26dB

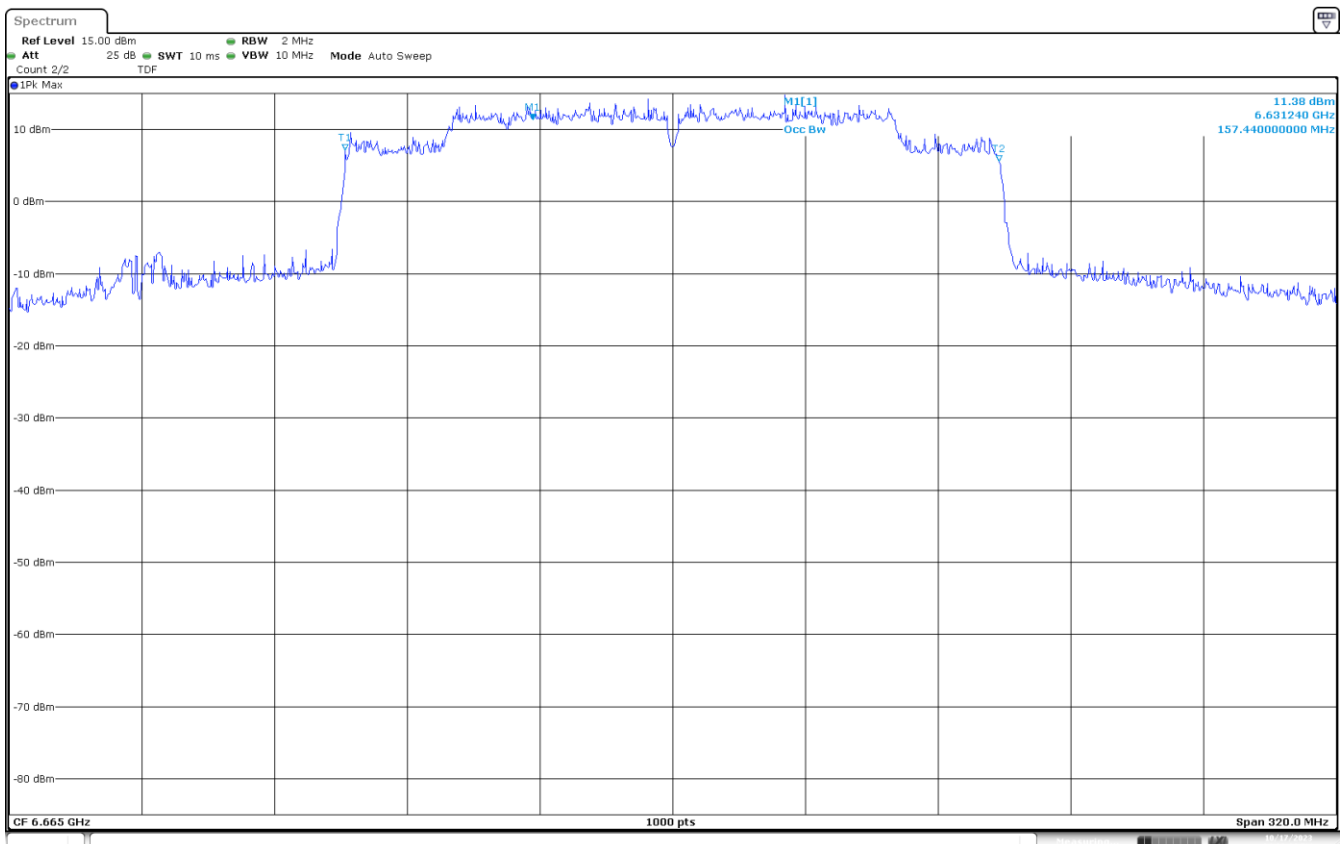

UNII-7 MIMO A 802.11ax160 CH143 6665MHz 99%

C.1.2 Maximum Output Power & Maximum power spectral Density

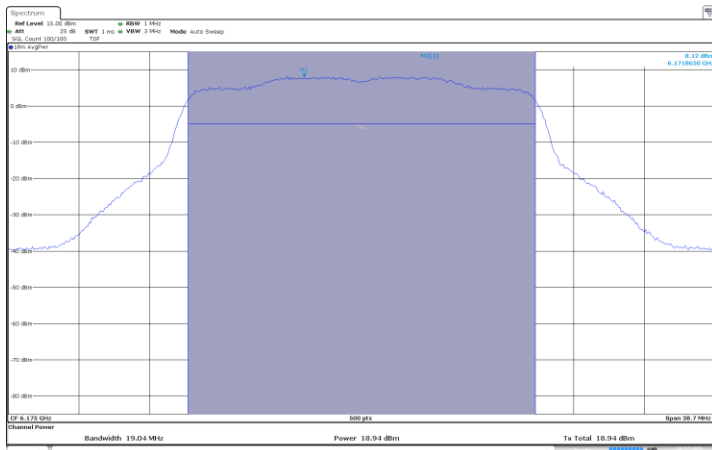

MIMO A-802.11ax-20MHz-Ch45-6175MHz-MCS0

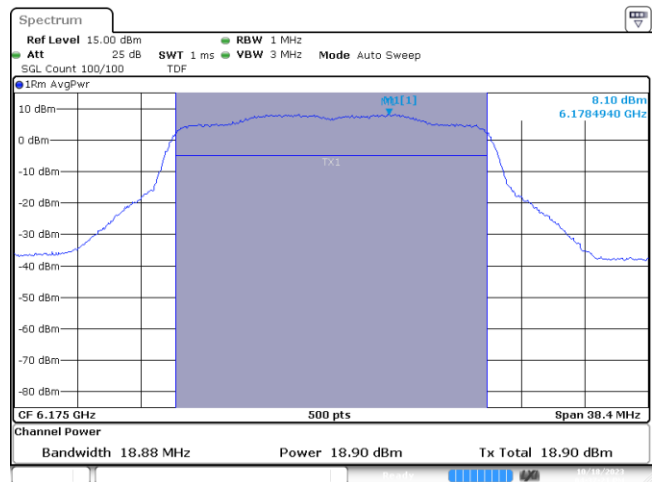

MIMO B-802.11ax-20MHz-Ch45-6175MHz-MCS0

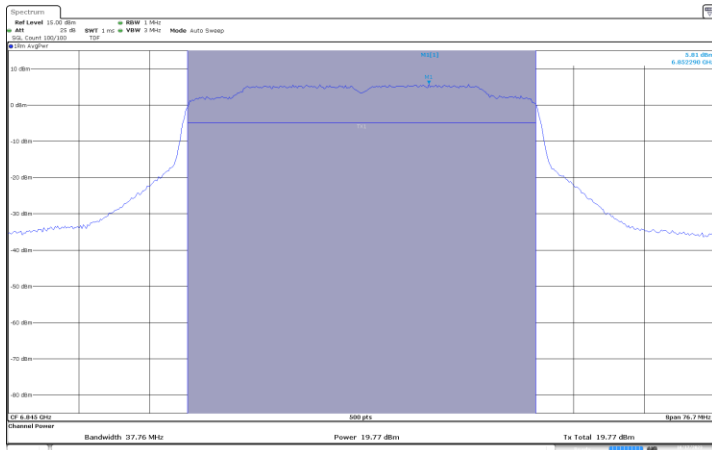

MIMO A-802.11ax-40MHz-Ch179-6845MHz-MCS0

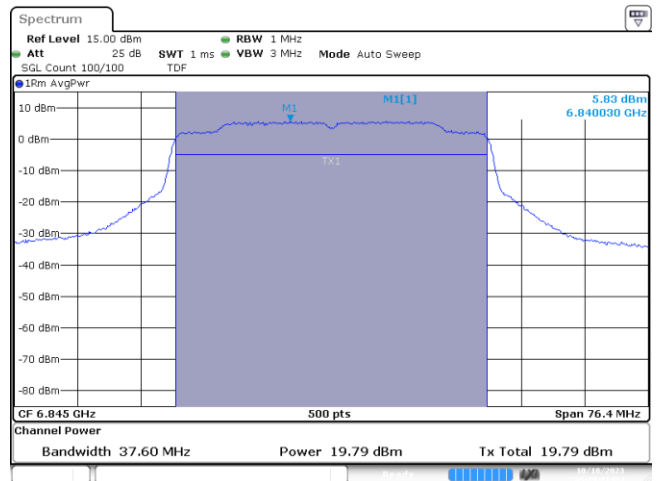

MIMO B-802.11ax-40MHz-Ch179-6845MHz-MCS0

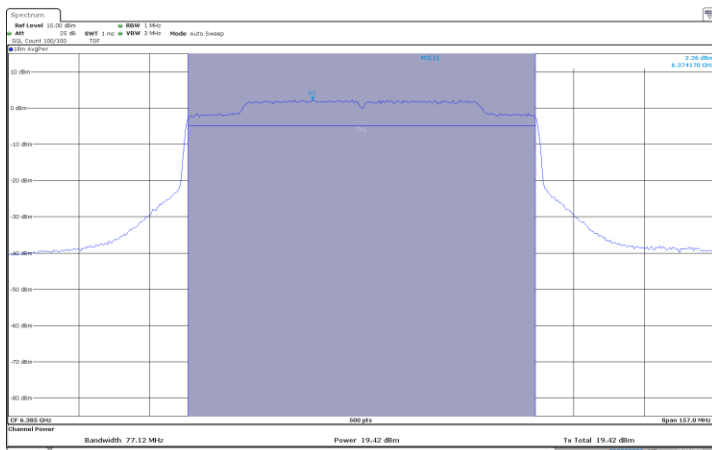

MIMO A-802.11ax-80MHz-Ch87-6385MHz-MCS0

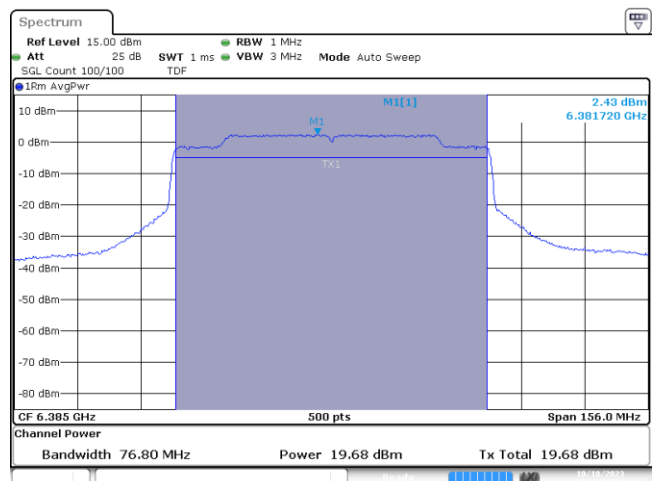

MIMO B-802.11ax-80MHz-Ch87-6385MHz-MCS0

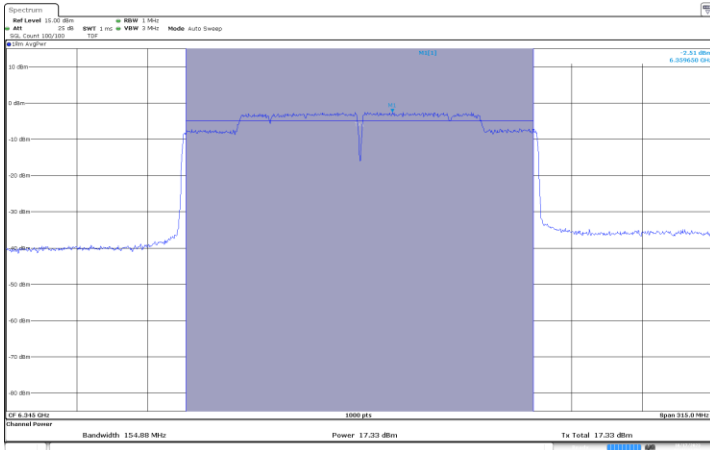

MIMO A-802.11ax-160MHz-Ch79-6345MHz-MCS0

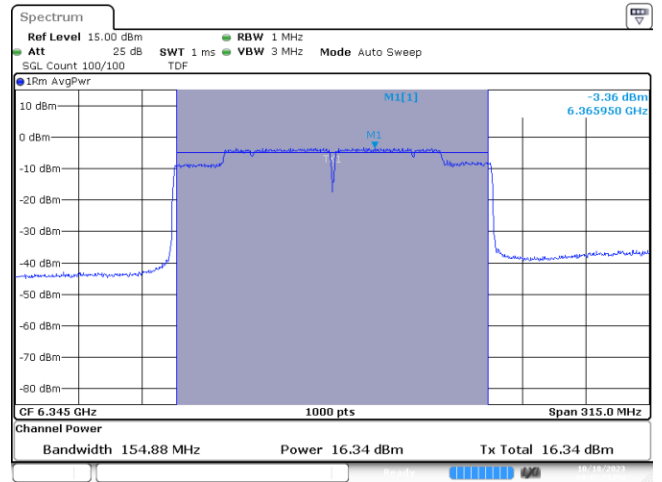

MIMO B-802.11ax-160MHz- Ch79-6345MHz-MCS0

C.1.3 In-Band Emissions (Mask)

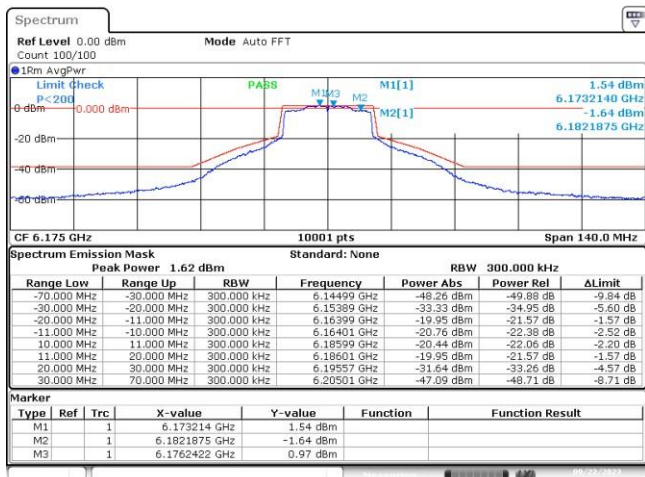

MIMO A-802.11ax-20MHz-Ch45-6175MHz-MCS0

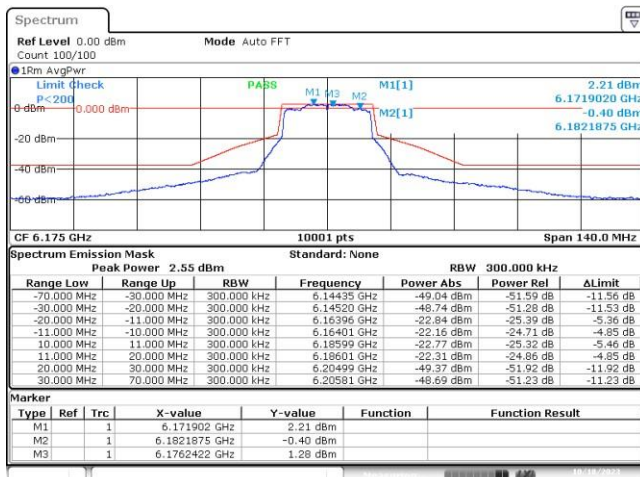

MIMO B-802.11ax-20MHz-Ch45-6175MHz-MCS0

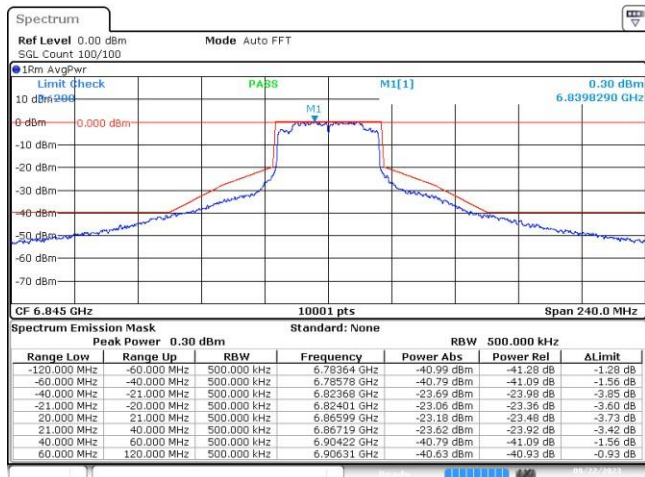

MIMO A-802.11ax-40MHz-Ch179-6845MHz-MCS0

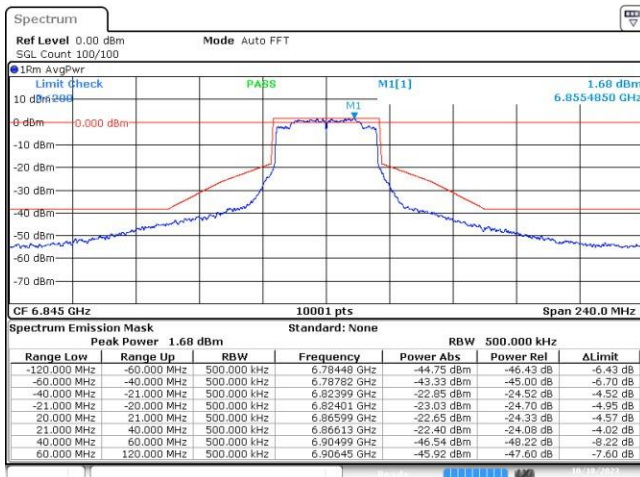

MIMO B-802.11ax-40MHz-Ch179-6845MHz-MCS0

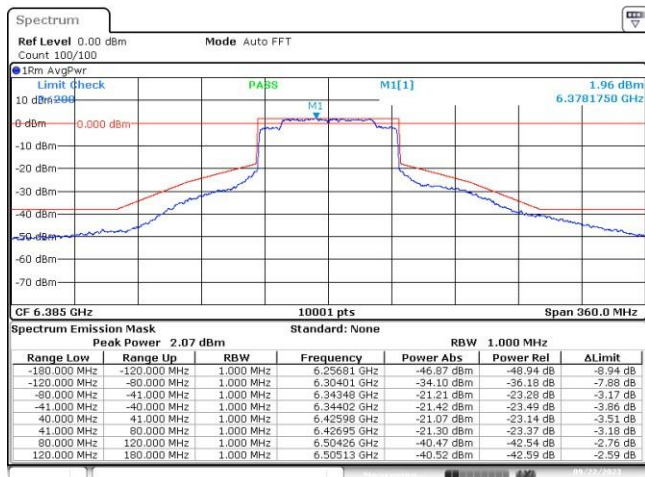

MIMO A-802.11ax-80MHz-Ch87-6385MHz-MCS0

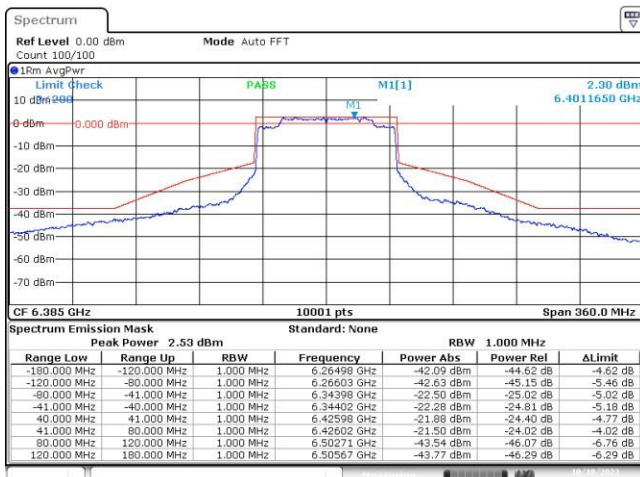

MIMO B-802.11ax-80MHz-Ch87-6385MHz-MCS0

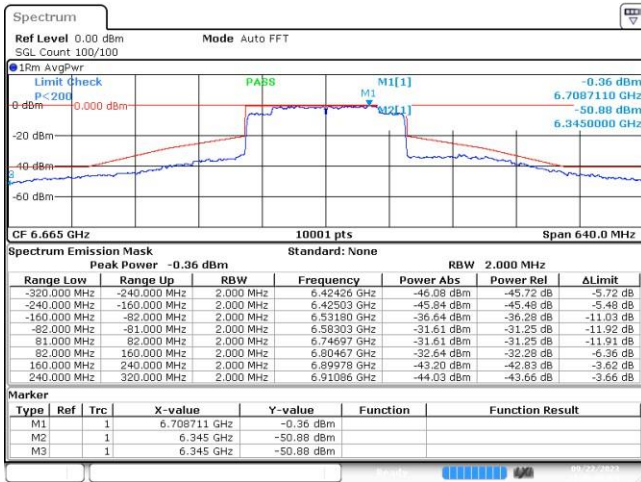

MIMO A-802.11ax-160MHz-Ch143-6665MHz-MCS0

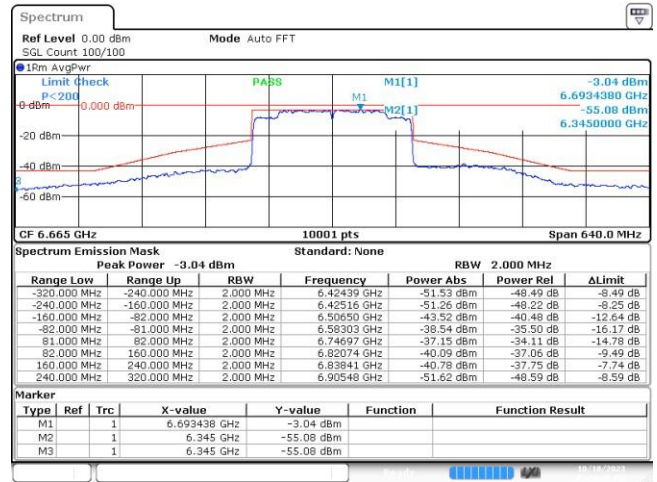

MIMO B-802.11ax-160MHz-Ch143-6665MHz-MCS0

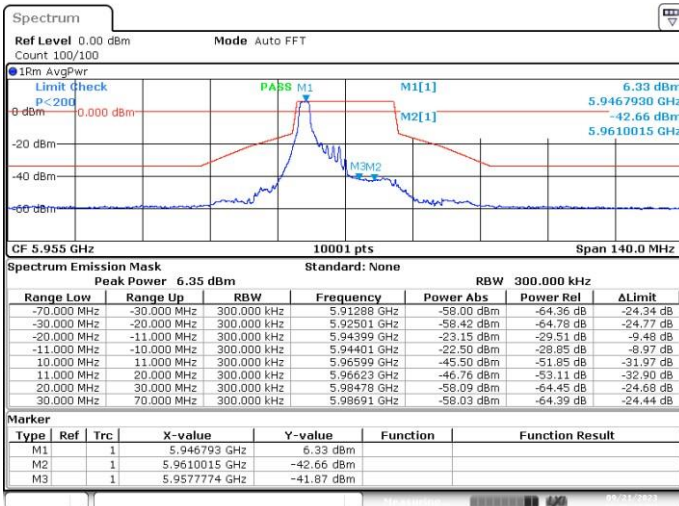

SISO-A, 802.11ax/be20-MCS0, Ch1-2m-0

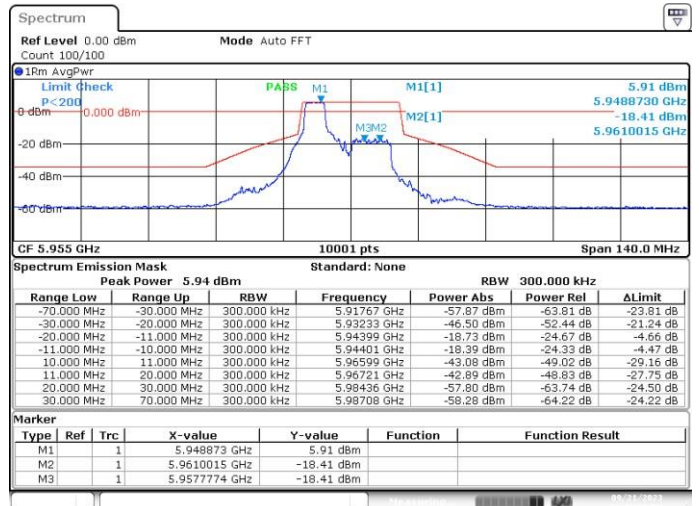

SISO-A, 802.11ax/be20-MCS0, Ch1-4m-37

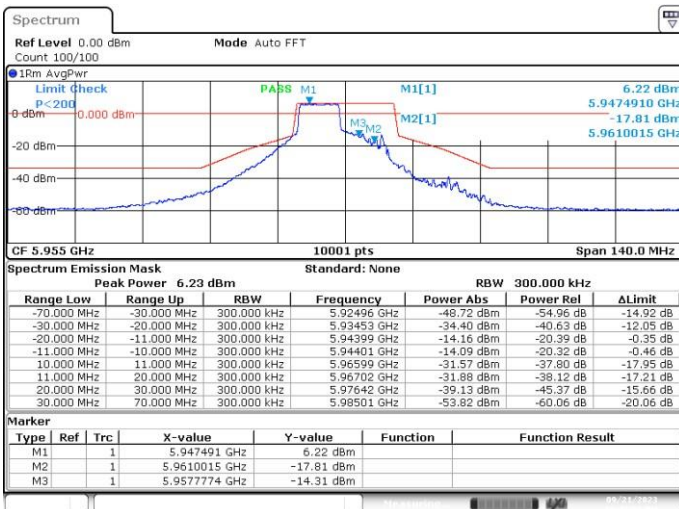

SISO-A, 802.11ax/be20-MCS0, Ch1-8m-53

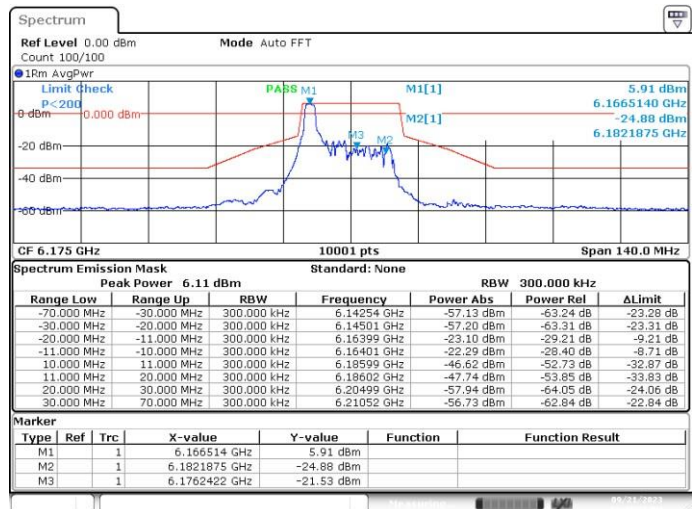

SISO-A, 802.11ax/be20-MCS0, Ch45-2m-0

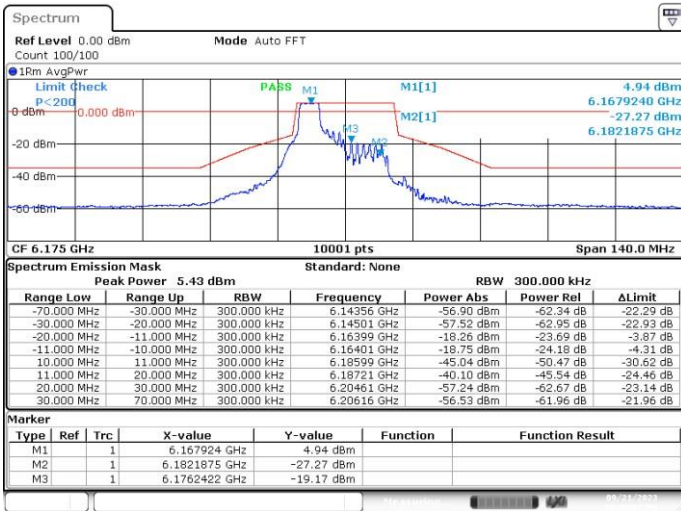

SISO-A, 802.11ax/be20-MCS0, Ch45-4m-37

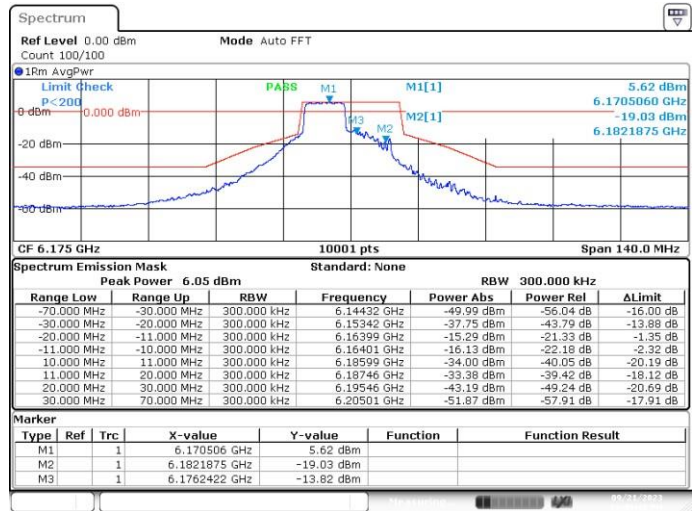

SISO-A, 802.11ax/be20-MCS0, Ch45-8m-53

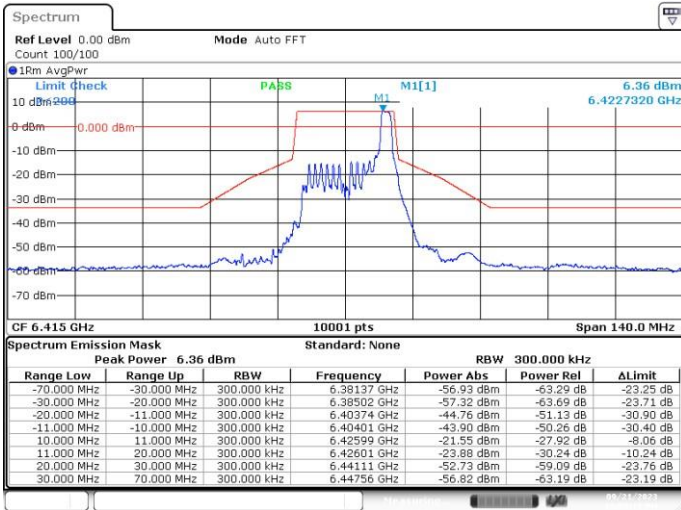

SISO-A, 802.11ax/be20-MCS0, Ch93-2m-0

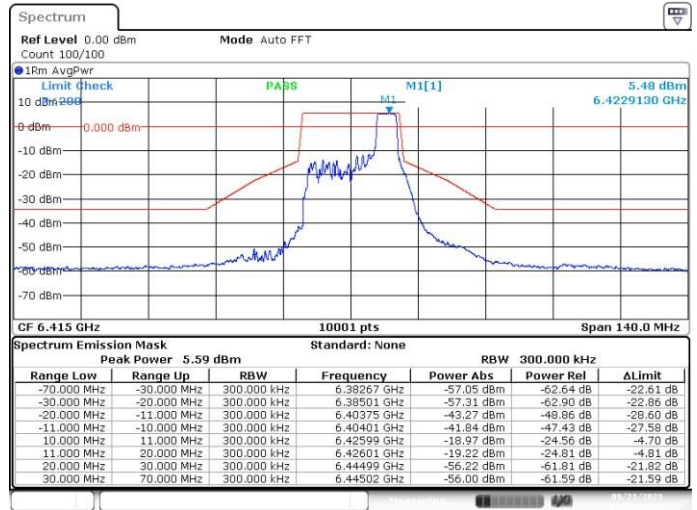

SISO-A, 802.11ax/be20-MCS0, Ch93-4m-37

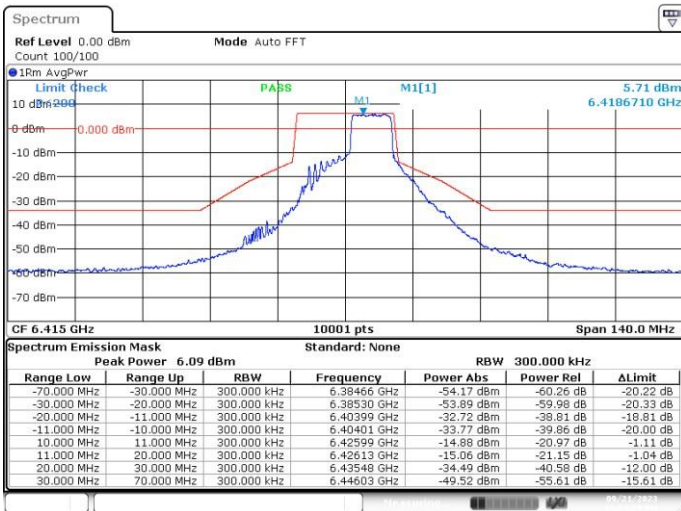

SISO-A, 802.11ax/be20-MCS0, Ch93-8m-53

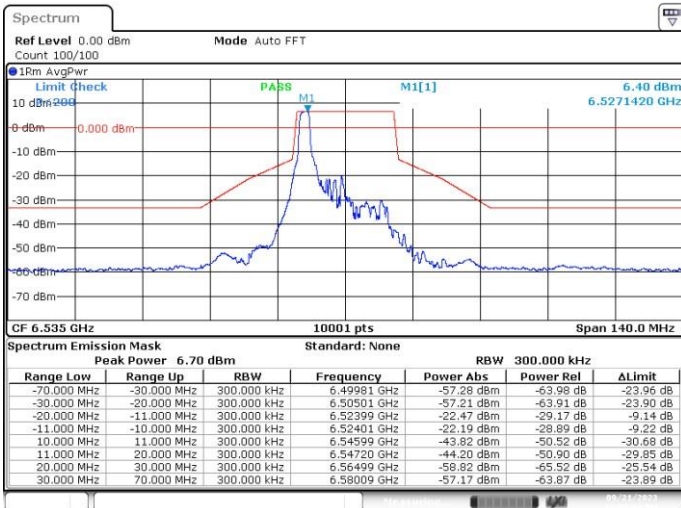

SISO-A, 802.11ax/be20-MCS0, Ch117-2m-0

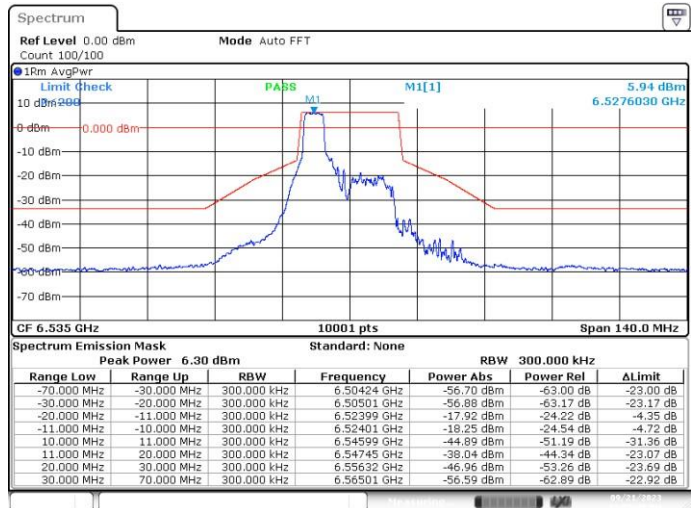

SISO-A, 802.11ax/be20-MCS0, Ch117-4m-37

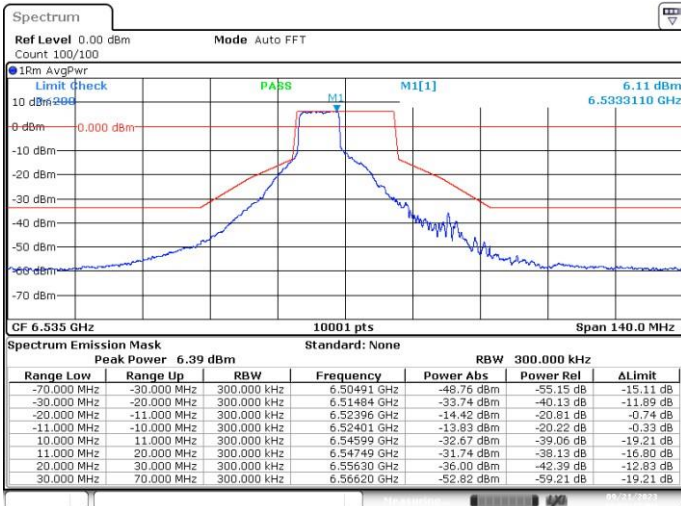

SISO-A, 802.11ax/be20-MCS0, Ch117-8m-53

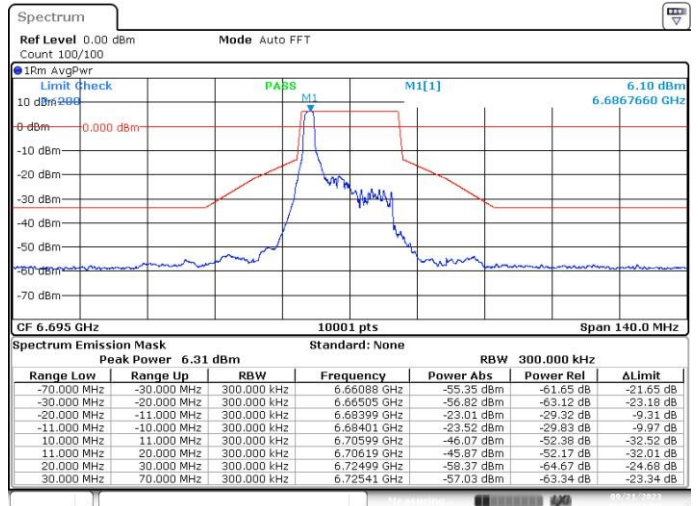

SISO-A, 802.11ax/be20-MCS0, Ch149-2m-0

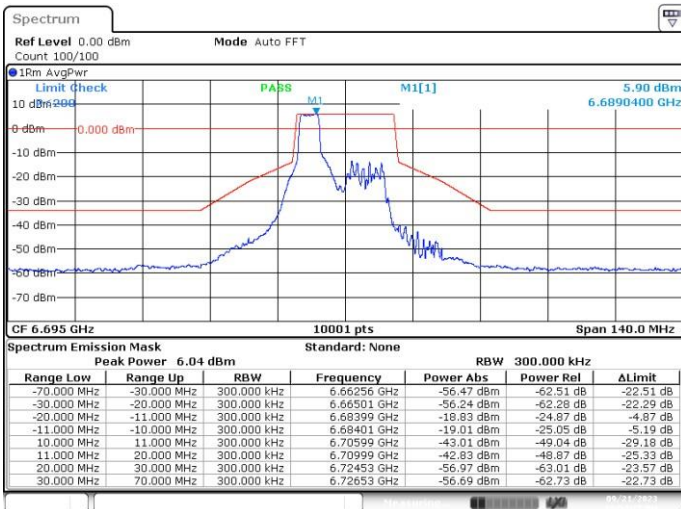

SISO-A, 802.11ax/be20-MCS0, Ch149-4m-37

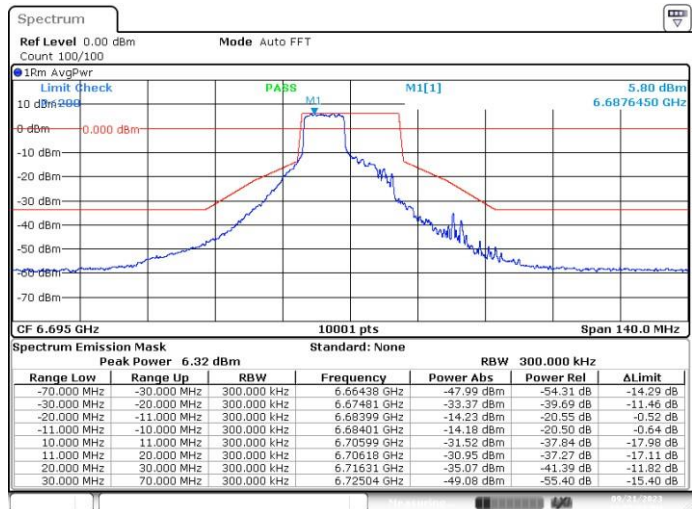

SISO-A, 802.11ax/be20-MCS0, Ch149-8m-53

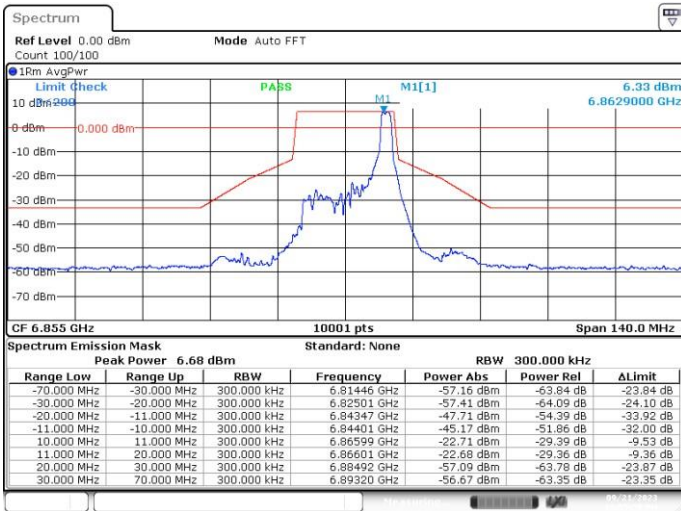

SISO-A, 802.11ax/be20-MCS0, Ch181-2m-0

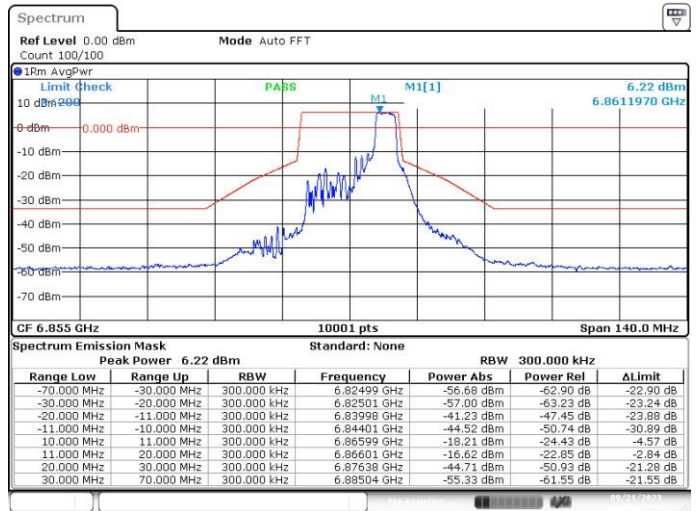

SISO-A, 802.11ax/be20-MCS0, Ch181-4m-37

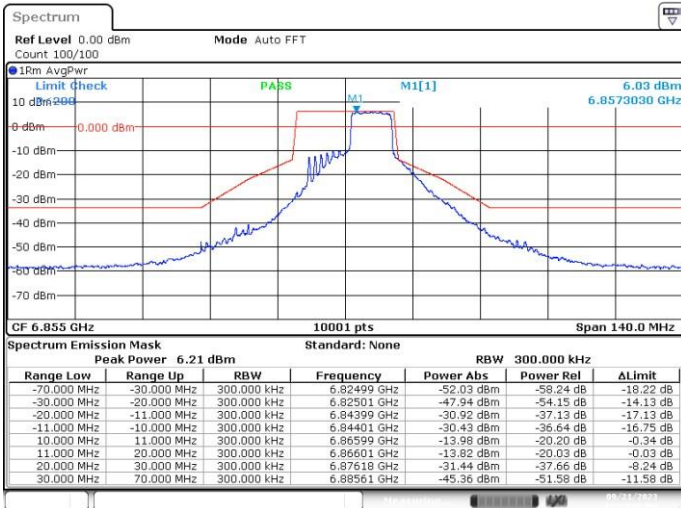

SISO-A, 802.11ax/be20-MCS0, Ch181-8m-53

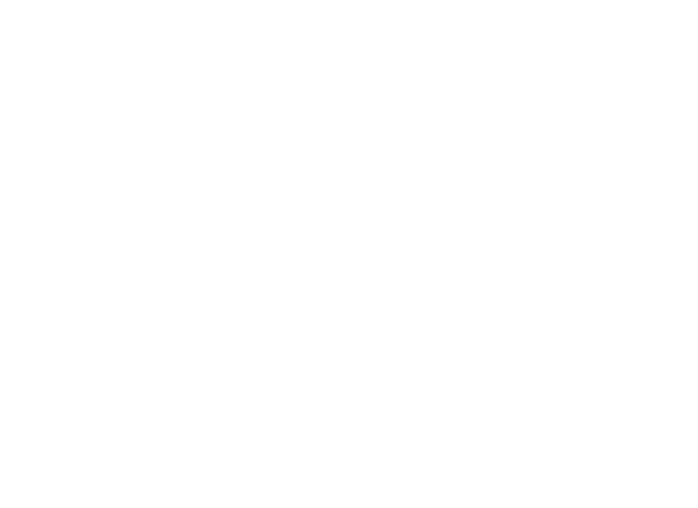

SISO-B, 802.11ax/be20-MCS0, Ch1-2m-0

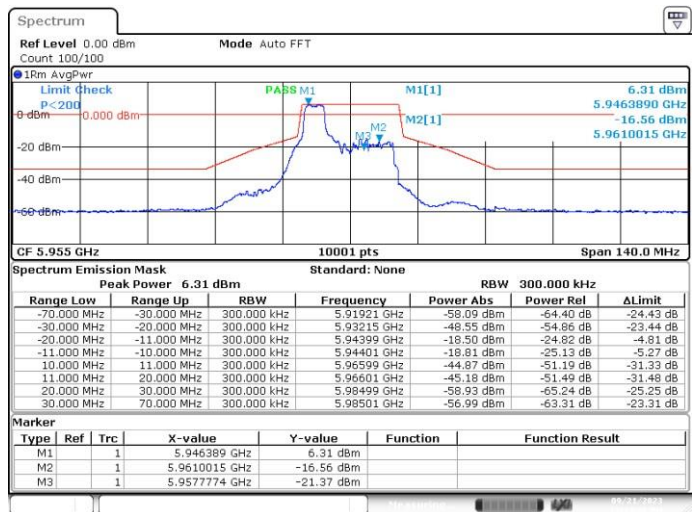

SISO-B, 802.11ax/be20-MCS0, Ch1-4m-37