

WiFi-2.4G Reference Antenna Datasheet

1. Antenna Specification

1.1. Antenna information

| Manufacturer | Type | Antenna Part number | Band | Peak Gain (dBi) | Target Peak Gain (dBi) |
|---------------|----------|------------------------|------------------------|-----------------|------------------------|
| Intel WRF Lab | Monopole | WRF-6dBi-Monopole-2.4G | 2.4GHz 2400-2500MHz | 6.11 | 6 |

1.2. Antenna Peak Gain Table

| Frequency (MHz) | Peak Gain | | |
|-----------------|------------------|------------------|-------|
| | Horizontal (Phi) | Vertical (Theta) | Total |
| | (dBi) | (dBi) | (dBi) |
| 2400 | -32.21 | 5.70 | 5.70 |
| 2430 | -28.23 | 6.03 | 6.03 |
| 2450 | -30.43 | 6.10 | 6.11 |
| 2470 | -27.92 | 6.18 | 6.19 |
| 2483 | -26.93 | 5.87 | 5.87 |

2. Antenna Radiation Patterns 2400 - 2483 MHz

2.1. Pattern @2400MHz

| Frequency (MHz) | Peak Gain | | |
|-----------------|------------------|------------------|-------|
| | Horizontal (Phi) | Vertical (Theta) | Total |
| | (dBi) | (dBi) | (dBi) |
| 2400 | -32.21 | 5.70 | 5.70 |

Front Total

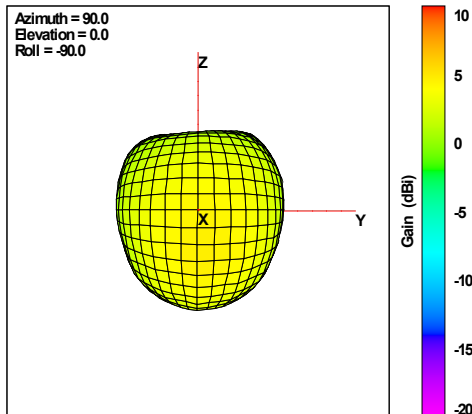

Back Total

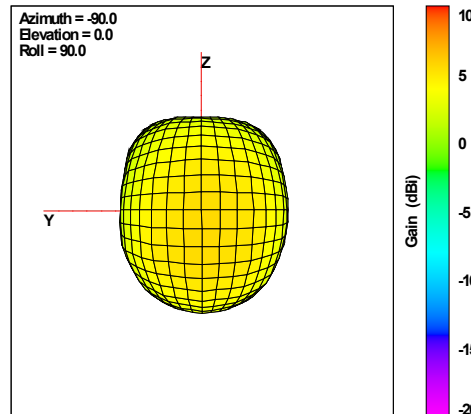

Left Total

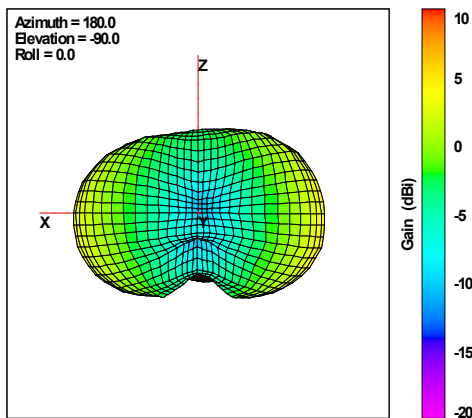

Right Total

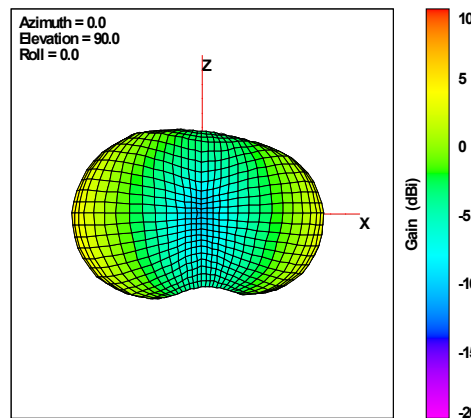

Top Total

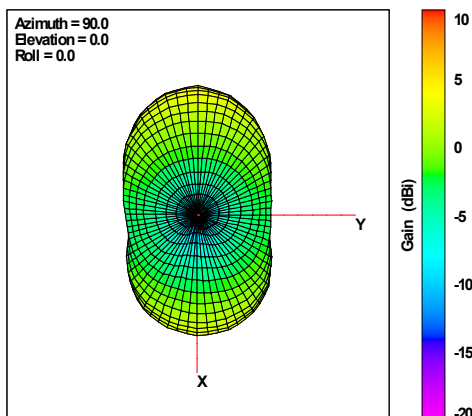

Bottom Total

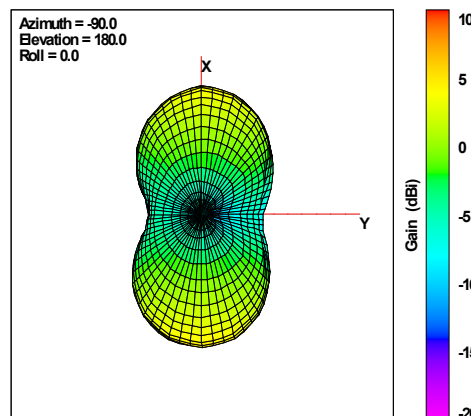

2.2. Pattern @2430MHz

| Frequency (MHz) | Peak Gain | | |
|-----------------|------------------|------------------|-------|
| | Horizontal (Phi) | Vertical (Theta) | Total |
| | (dBi) | (dBi) | (dBi) |
| 2430 | -28.23 | 6.03 | 6.03 |

Front Back

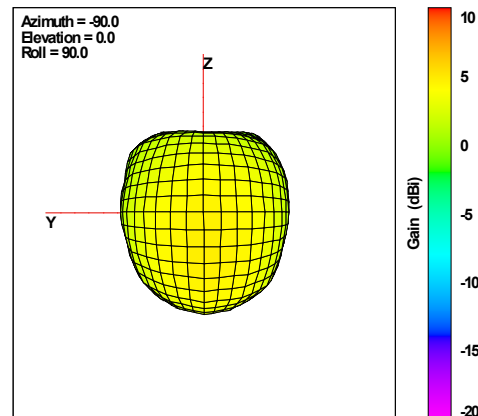
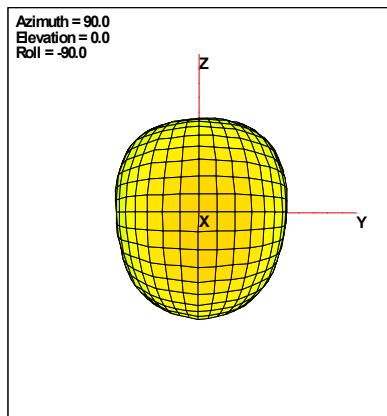

Left Right

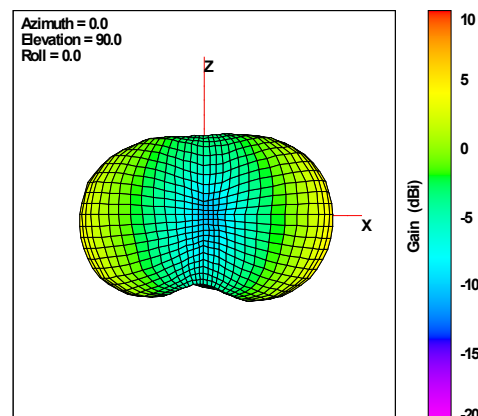
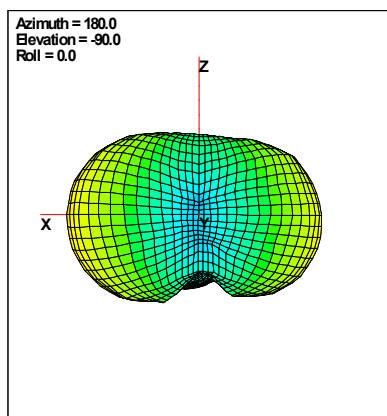

Top Bottom

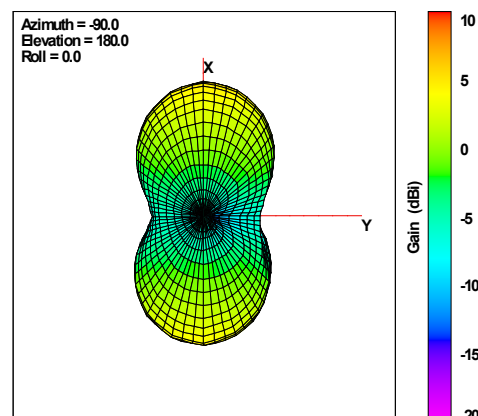
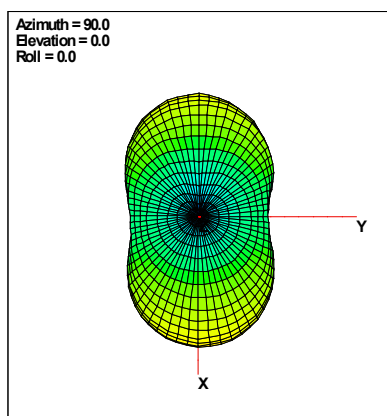

2.3. Pattern @2450MHz

| Frequency (MHz) | Peak Gain | | |
|-----------------|------------------|------------------|-------|
| | Horizontal (Phi) | Vertical (Theta) | Total |
| | (dBi) | (dBi) | (dBi) |
| 2450 | -30.43 | 6.10 | 6.11 |

Front **Back**

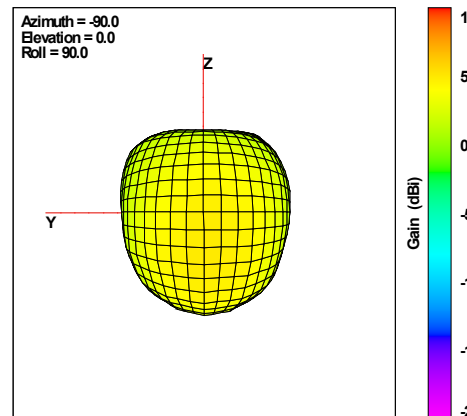
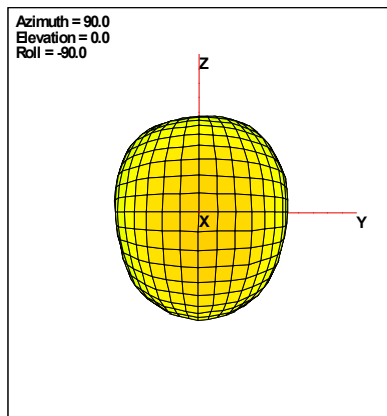

Left **Right**

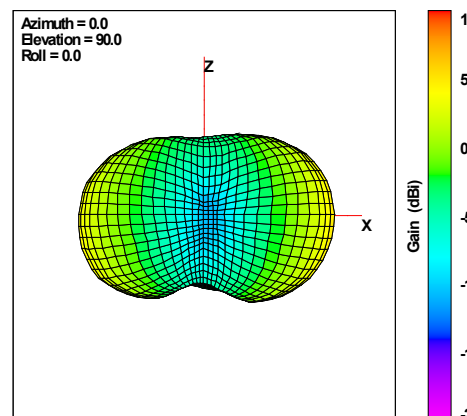
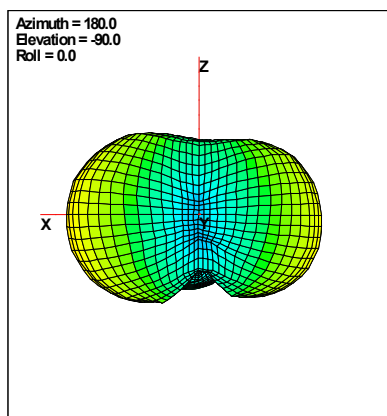

Top **Bottom**

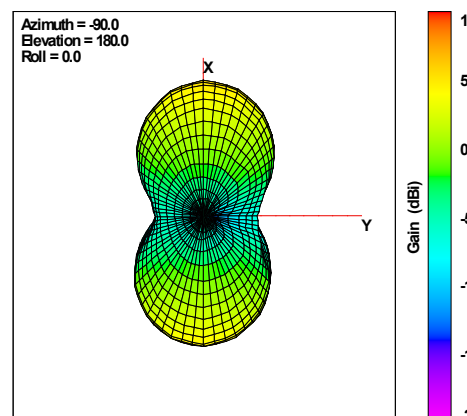
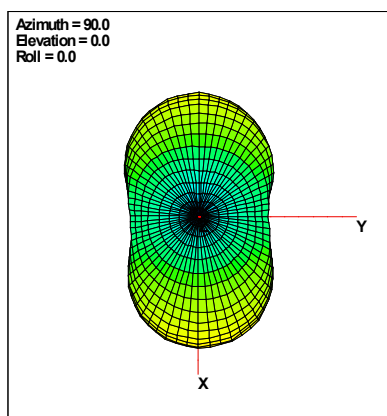

2.4. Pattern @2470MHz

| Frequency (MHz) | Peak Gain | | |
|-----------------|------------------|------------------|-------|
| | Horizontal (Phi) | Vertical (Theta) | Total |
| | (dBi) | (dBi) | (dBi) |
| 2470 | -27.92 | 6.18 | 6.19 |

Front **Back**

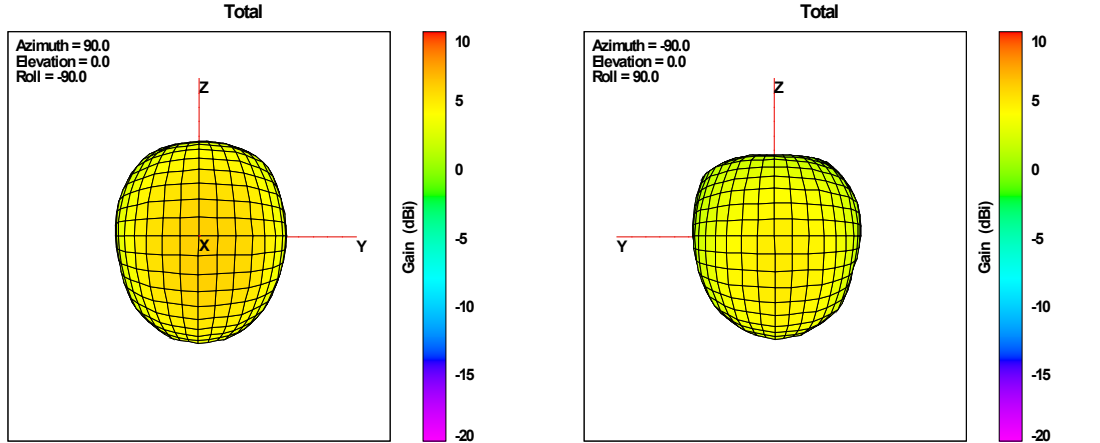

Left **Right**

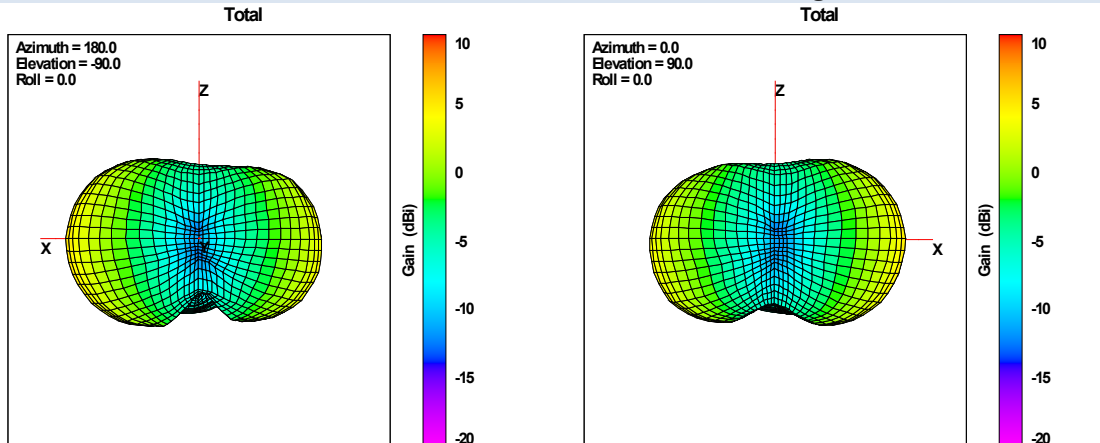

Top **Bottom**

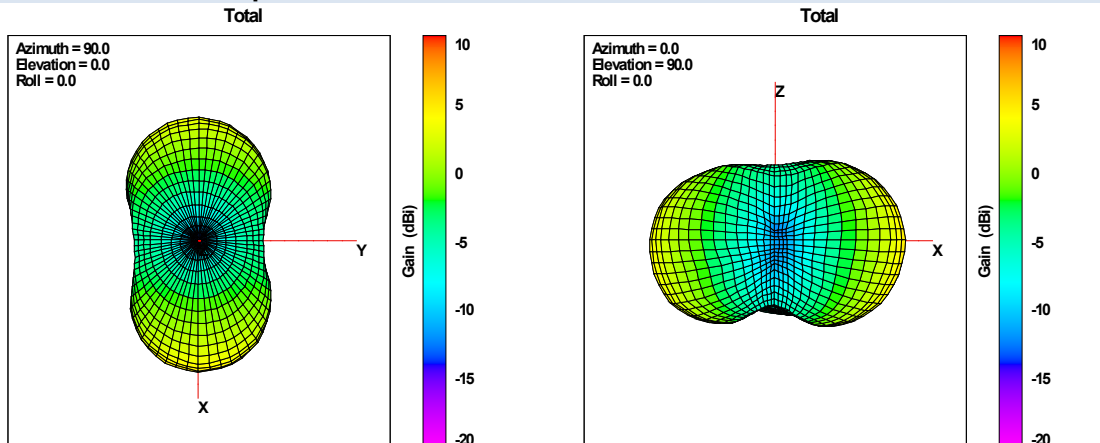

2.5. Pattern @2483MHz

| Frequency (MHz) | Peak Gain | | |
|-----------------|------------------|------------------|-------|
| | Horizontal (Phi) | Vertical (Theta) | Total |
| | (dBi) | (dBi) | (dBi) |
| 2483 | -26.93 | 5.87 | 5.87 |

Front **Back**

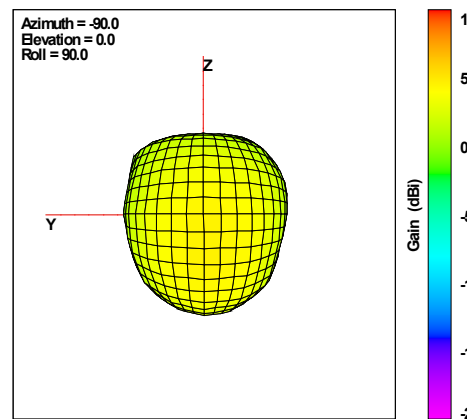
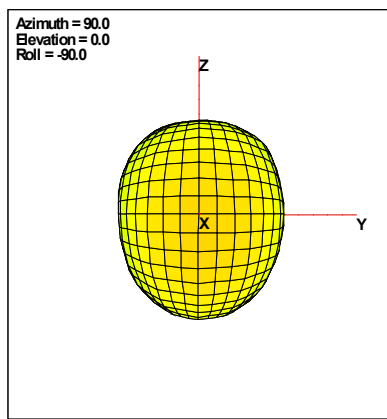

Left **Right**

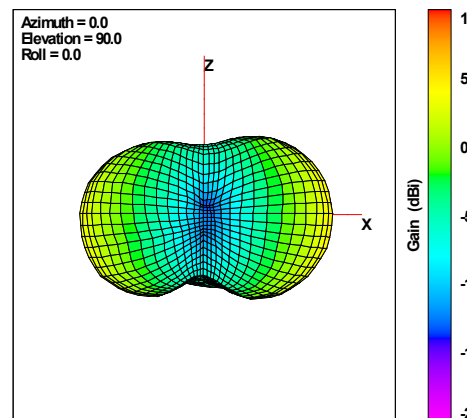
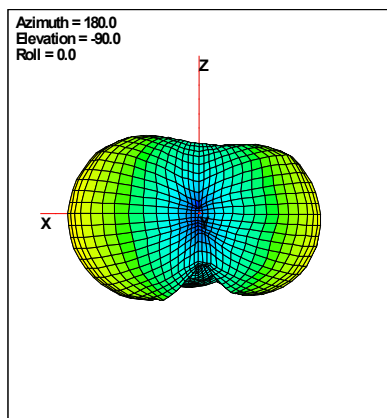

Top **Bottom**

