

# ANTENNA INFORMATION

OEM	Lenovo
ODM	Wistron
Platform model name	TP00118B; ThinkPad X12 Detachable Gen 2
Intel platform (ex: Yes, No or NA)	Yes
Platform type (ex: regular NB, convertible PC, AIO...etc)	Detachable PC
SAR minimum separation (mm)	3.1

Antenna manufacturer	High-Tek Electronics Co., Ltd		
Address	17F., No.100, Sec. 1, Xintai 5th Rd., Xizhi Dist., New Taipei City 22102, Taiwan (R.O.C.)		
Antenna Part number	Main: 025.902C8.0001 (0ACAR023025N)	Aux: 025.902C9.0001 (0ACAR023026N)	
Antenna type (ex: PIFA, Dipole...etc)	PIFA		

Antenna Peak gain w/ cable loss (dBi)*										
	2.4GHz 2400-2483.5 MHz	5.2GHz 5150-5250MHz	5.3GHz 5250-5350MHz	5.6GHz 5470-5725MHz	5.8GHz 5725-5850MHz	5.9GHz 5850-5895MHz	6.2GHz 5925-6425MHz	6.5GHz 6425-6525MHz	6.7GHz 6525-6875MHz	7.0 GHz 6875-7125MHz
Main	2.46	2.65	2.65	1.96	2.03	3.30	4.24	3.88	4.28	3.79
Aux	2.44	1.46	1.46	2.47	2.48	2.53	4.35	3.74	3.74	3.05

Cable Assembly Part Number and Information					
	Cable PN	Cable length(cm)	Cable diameter(mm)	Impedance(ohm)	Connector type
Main	SY081L/50	6.2	0.81	50	NGFF
Aux	SY113L/50	2.1	1.13	50	NGFF

\* 3D Antenna Peak Gain required being test in system basis.

# Table of Contents

Cover page.....	1
<b>1. Intel Reference Gain and Type.....</b>	<b>3</b>
<b>2. Document Revision History.....</b>	<b>3</b>
<b>3. Test &amp; System Description</b>	
3.1 Measurement Method and System.....	4
3.2 Test setup.....	4
3.3 Equipment list.....	5
<b>4. Radiation characteristics of antenna loaded in Host Platform.....</b>	<b>6</b>
<b>Annex A. Photographs</b>	
A.1 Setup Photo.....	16
A.2 Test sample.....	17
<b>Annex B. Antenna Location</b>	
B.1 Antenna Host Platform Location Information.....	19
B.2 Antenna dimensional information for SAR evaluation.....	20

## 1. Intel Reference Gain and Type

Antenna Peak gain w/ cable loss (dBi)											
Band/Frequency		2.4GHz 2400-2483.5 MHz	5.2GHz 5150-5250MHz	5.3GHz 5250-5350MHz	5.6GHz 5470-5725MHz	5.8GHz 5725-5850MHz	5.9GHz 5850-5895MHz	6.2GHz 5925-6425MHz	6.5GHz 6425-6525MHz	6.7GHz 6525-6875MHz	7.0 GHz 6875-7125MHz
Design	EU/UK	3.00	5.00	5.00	5.00	5.00	5.00	5.00	5.00	5.00	5.00
PIFA	For WiFi 6E and earlier	3.24	3.64	3.73	4.77	4.97	4.72	4.83	4.30	5.37	5.59
	From WiFi 7	2.95	5.11	4.55	5.15	5.13	4.45	5.02	5.02	4.96	4.96
Dipole	For WiFi 6E and earlier	2.89	2.92	3.19	4.41	4.22	4.22	4.83	4.30	4.49	5.34
	From WiFi 7	2.95	4.03	4.11	5.15	5.13	4.45	5.02	4.71	4.49	4.96

### 3D Peak Antenna gain should be equal or greater than -2 dBi

If a host integrator plans to use a lower gain antenna of the same type, additional CBP(FCC)/EDT(EU) testing need to be performed while the module is installed in the host.

## 2. Document Revision History

Revision #	Revision Details	Issued Date
Rev. 00	First Issue	2023.11.20

### 3. Test & System Description

#### 3.1 Measurement Method and System

The radiation pattern of antenna is measured in both horizontal polarization and vertical polarization. The radiation pattern measurements are performed in the three-dimensional anechoic chamber. The chamber provides less than  $-30\text{dB}$  reflectivity from  $800\text{MHz}$  through  $8\text{GHz}$ . The chamber is calibrated using both standard dipole antenna and horn antenna. The Gain here is expressed as  $\text{dBi}$  that standardizes the isotropic antenna. The Gain measurements and antenna radiation pattern are also performed in the same chamber described previously. Figure shows the schematic diagram for measuring radiation pattern and Gain.

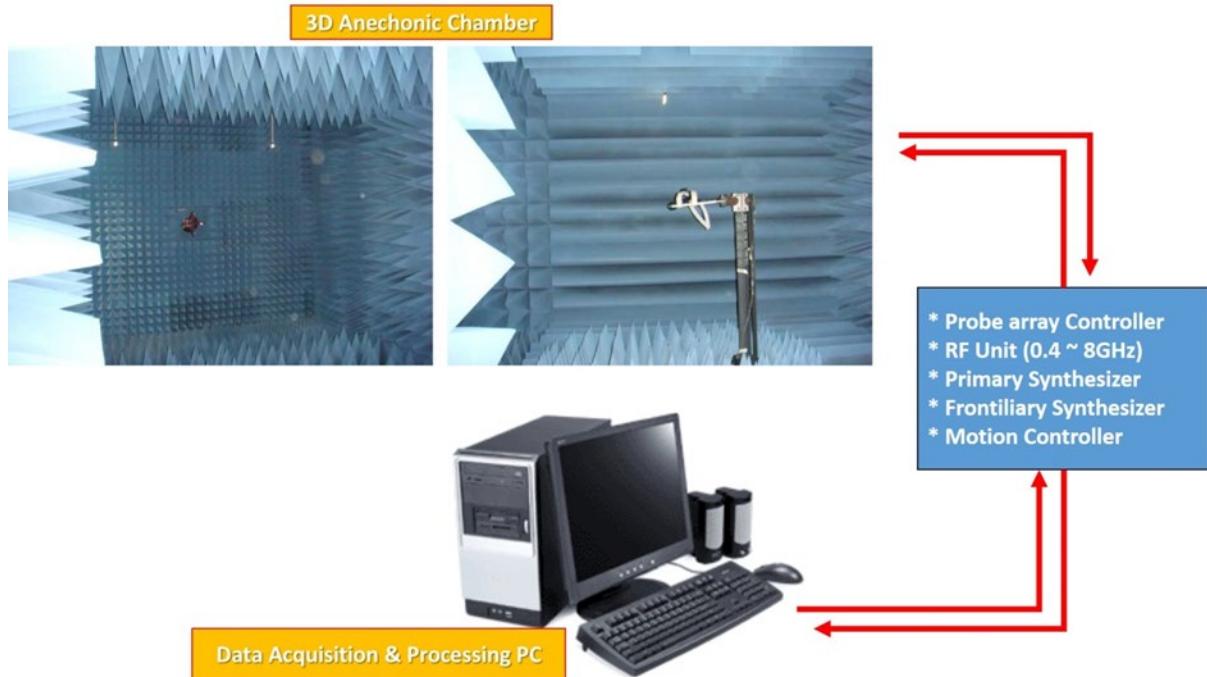

### 3.2 Test setup

#### 1. Frequency Range

2400~2500MHz, for WLAN application.

5150~7125MHz, for WLAN application

#### 2. Antenna Configuration

The antenna basically has two parts; the stamping and the cable assembly with the connector on one side. The detailed drawing is attached.

#### 3. VSWR

The VSWR is measured with network analyzer that support up to 8GHz. All the measurements are performed with the customer provided fixture. Figure 1 shows the typical schematic diagram for measuring VSWR.

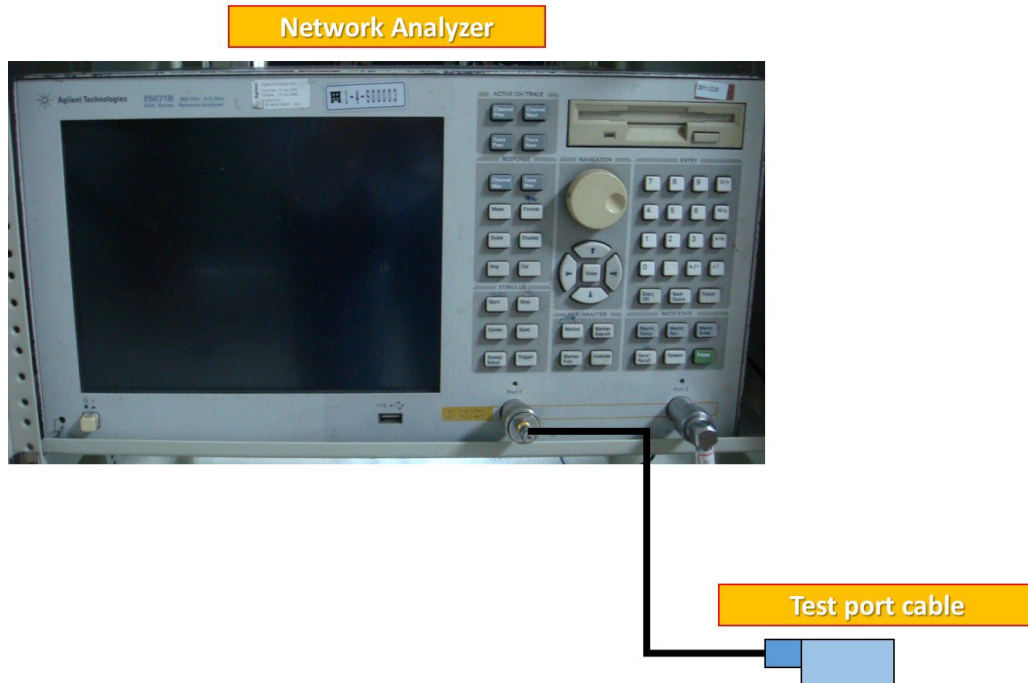

Figure 1. The schematic diagram for measuring VSWR

### 3.3 Equipment list

The equipment for the antenna measurement we used is as follows:

- A. Network Analyzer, support up to 8GHz, to measure the VSWR and input impedance of antenna.
- B. Three-dimensional anechoic chamber to measure antenna gain and radiation pattern(Standard horn antenna was used to calibrate the chamber)
- C. Digital caliper to measure the dimensions.
- D. Climatic chamber for mechanical tests.

#### Radiated Setup

item	Device	Type/Model	manufacturer	Cal. Date	Cal. Due Date
1	Anechoic Chamber	AMS-8500	ETS-Lindgren	2023/01/30	2024/01/30
2	Turn Table	ETS	ETS-Lindgren	N/A	N/A
3	Measurement SW	EMQuest1.08	ETS-Lindgren	N/A	N/A
4	Vector Network Analyzer	Agilent E5071B	Agilent	2023/01/30	2024/01/30
5	Receive Antenna Absorber Nested Dual- Polarized Dual-Vivaldi Array Antenna 700MHz to 6GHz	EMCO 3164-08	ETS-Lindgren	N/A	N/A
6	Multi Axis Positioning System (MAPS™)	EMCO 2115CR	ETS-Lindgren	N/A	N/A
7	MAPS™ Controller	MECO 2090	ETS-Lindgren	N/A	N/A
8	Horn antenna	3164-08	ETS-Lindgren	2023/01/30	2024/01/30
9	Cable 0.5m - 700MHz~10GHz	RG316	Senyu	2023/01/30	2024/01/30

N/A : Not Applicable

#### 4. Radiation characteristics of antenna loaded in Host Platform

##### Main Antenna

Max Antenna 3D Radiation Pattern 2400 – 2483.5 MHz

Frequency (MHz)	Peak Gain w/ Cable Loss (dBi)
2400-2483.5	2.46

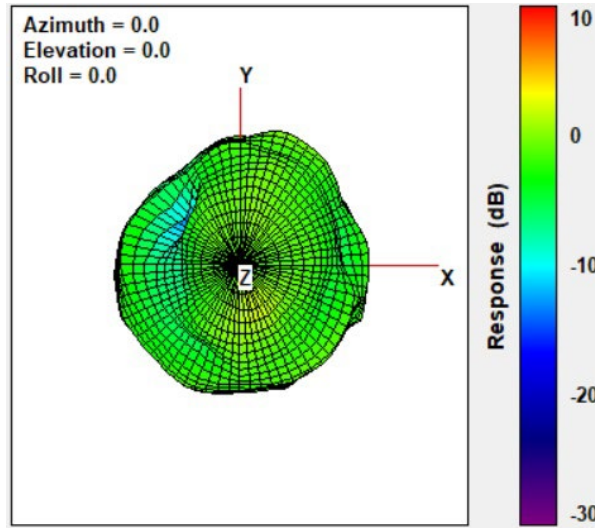

Max Antenna 3D Radiation Pattern 5150-5250 MHz

Frequency (MHz)	Peak Gain w/ Cable Loss (dBi)
5150-5250	2.65

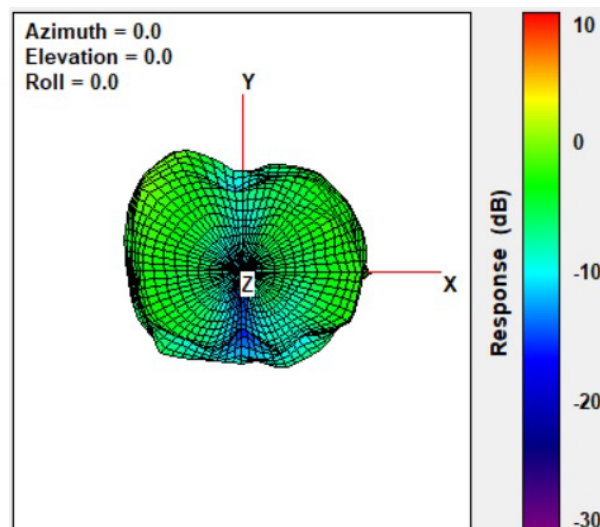

### Max Antenna 3D Radiation Pattern 5250-5350 MHz

Frequency (MHz)	Peak Gain w/ Cable Loss (dBi)
5250-5350	2.65

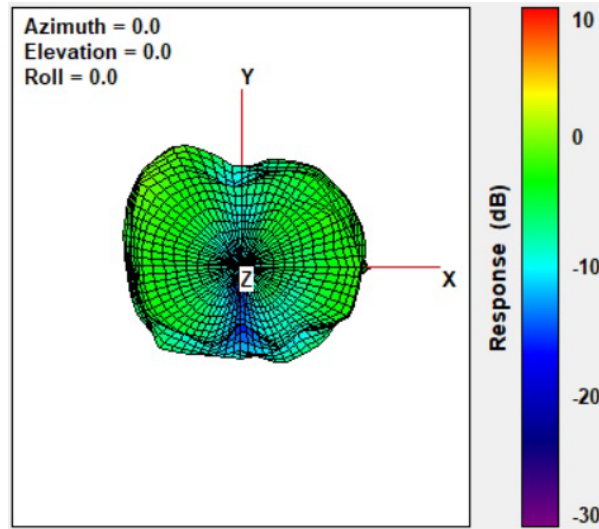

### Max Antenna 3D Radiation Pattern 5470-5725 MHz

Frequency (MHz)	Peak Gain w/ Cable Loss (dBi)
5470-5725	1.96

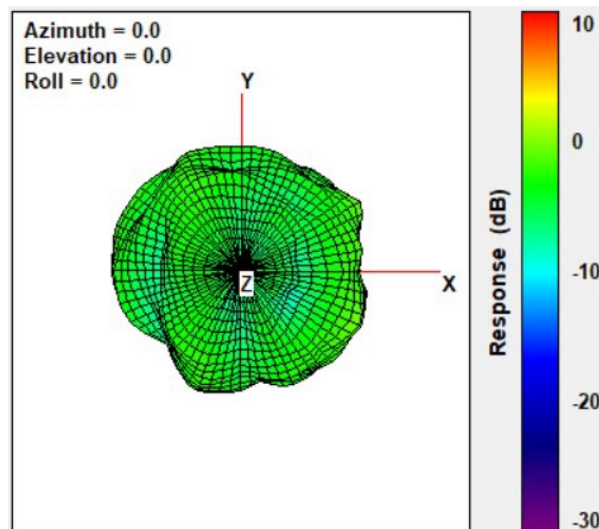



### Max Antenna 3D Radiation Pattern 5725-5850 MHz

Frequency (MHz)	Peak Gain w/ Cable Loss (dBi)
5725-5850	2.03

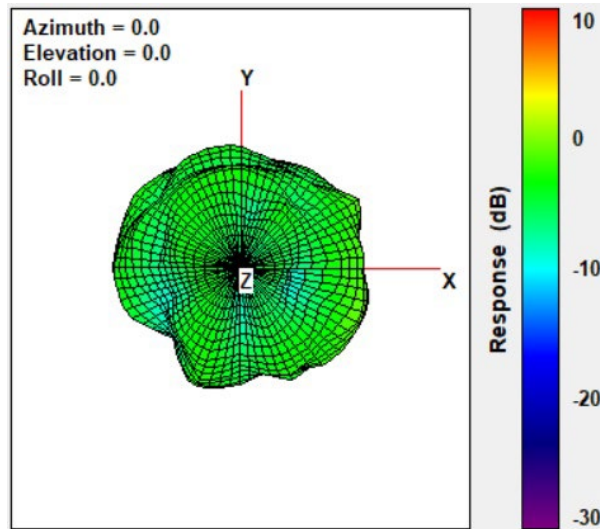

### Max Antenna 3D Radiation Pattern 5850-5895 MHz

Frequency (MHz)	Peak Gain w/ Cable Loss (dBi)
5850-5895	3.30

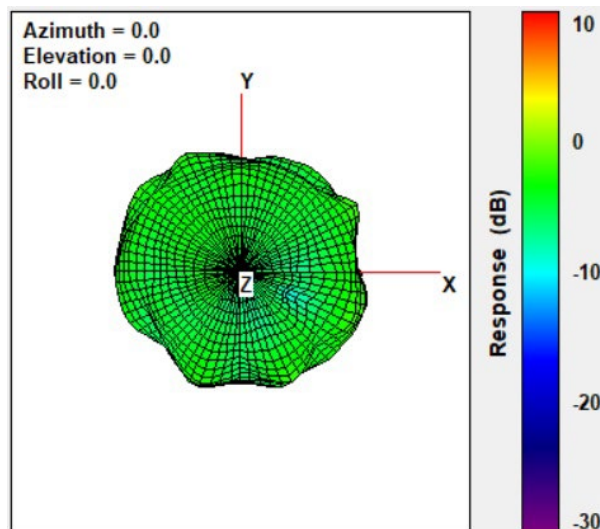

### Max Antenna 3D Radiation Pattern 5925-6425 MHz

Frequency (MHz)	Peak Gain w/ Cable Loss (dBi)
5925-6425	4.24

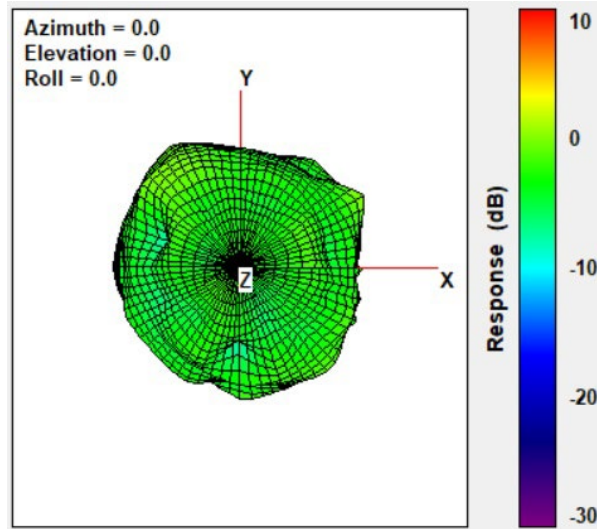

### Max Antenna 3D Radiation Pattern 6425-6525 MHz

Frequency (MHz)	Peak Gain w/ Cable Loss (dBi)
6425-6525	3.88

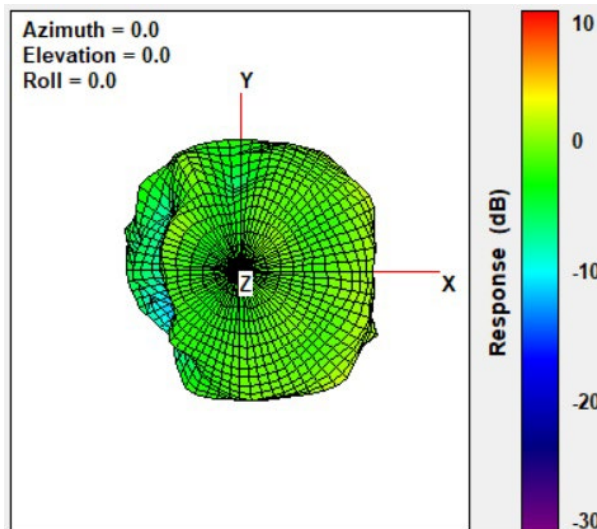

### Max Antenna 3D Radiation Pattern 6525-6875 MHz

Frequency (MHz)	Peak Gain w/ Cable Loss (dBi)
6525-6875	4.28

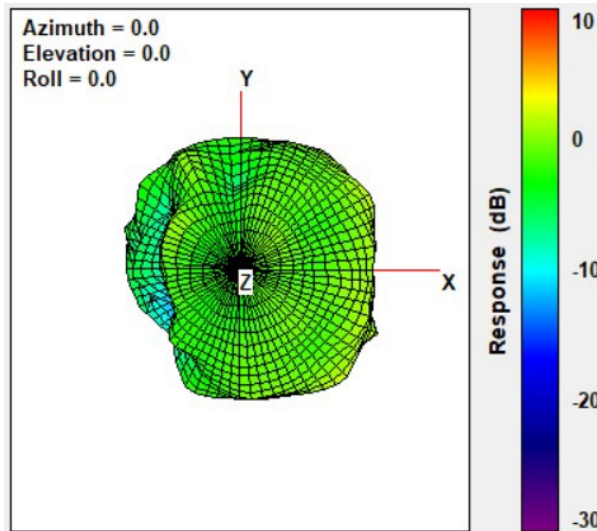

### Max Antenna 3D Radiation Pattern 6875-7125 MHz

Frequency (MHz)	Peak Gain w/ Cable Loss (dBi)
6875-7125	3.79

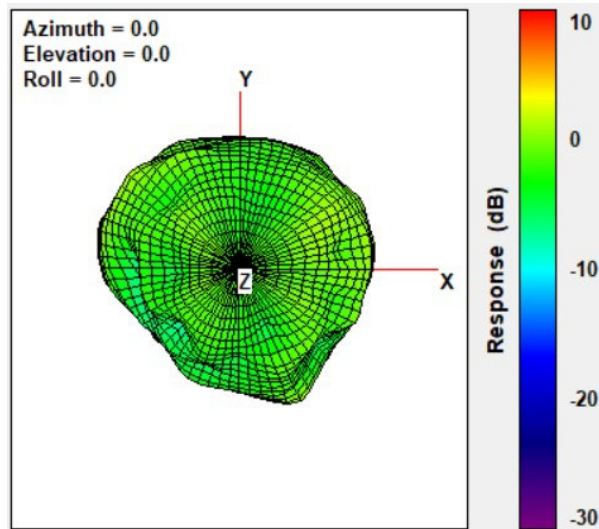

### Auxiliary Antenna

Max Antenna 3D Radiation Pattern 2400 – 2483.5 MHz

Frequency (MHz)	Peak Gain w/ Cable Loss (dBi)
2400-2483.5	2.44

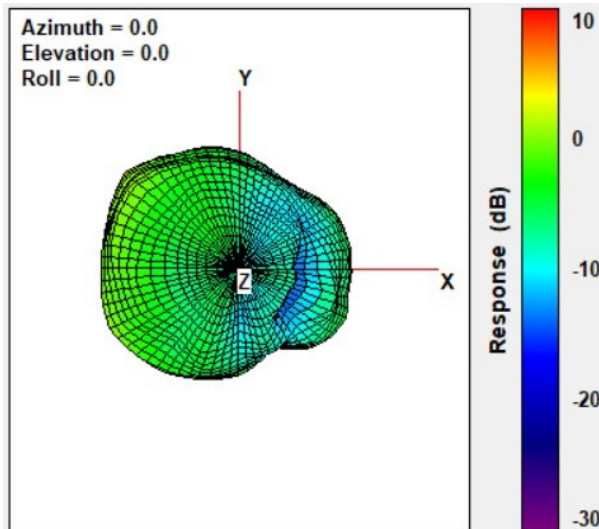

Max Antenna 3D Radiation Pattern 5150-5250 MHz

Frequency (MHz)	Peak Gain w/ Cable Loss (dBi)
5150-5250	1.46

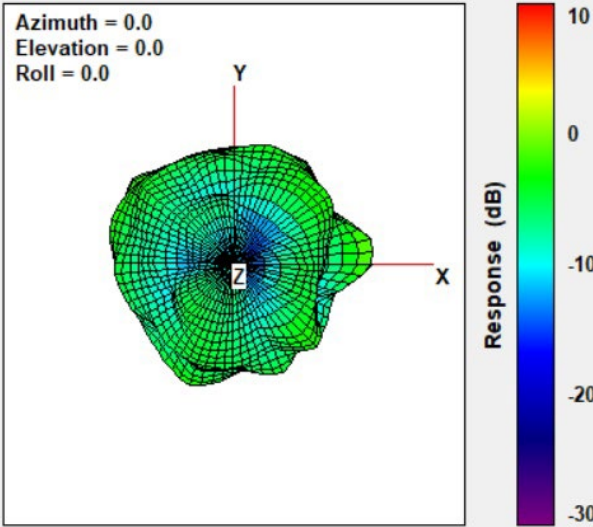

### Max Antenna 3D Radiation Pattern 5250-5350 MHz

Frequency (MHz)	Peak Gain w/ Cable Loss (dBi)
5250-5350	1.46

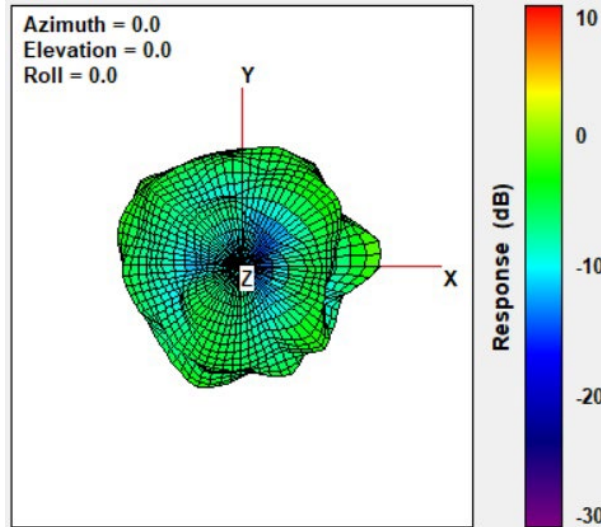

### Max Antenna 3D Radiation Pattern 5470-5725 MHz

Frequency (MHz)	Peak Gain w/ Cable Loss (dBi)
5470-5725	2.47

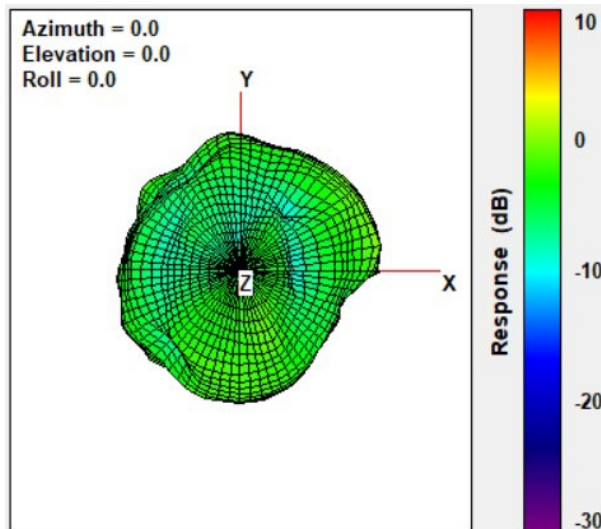

### Max Antenna 3D Radiation Pattern 5725-5850 MHz

Frequency (MHz)	Peak Gain w/ Cable Loss (dBi)
5725-5850	2.48

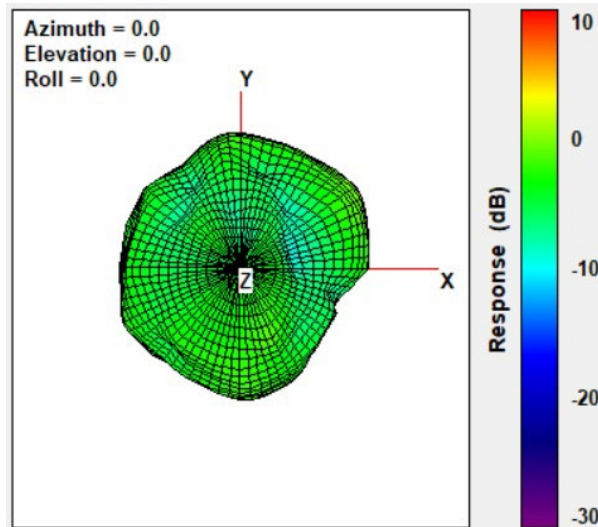

### Max Antenna 3D Radiation Pattern 5850-5895 MHz

Frequency (MHz)	Peak Gain w/ Cable Loss (dBi)
5850-5895	2.53

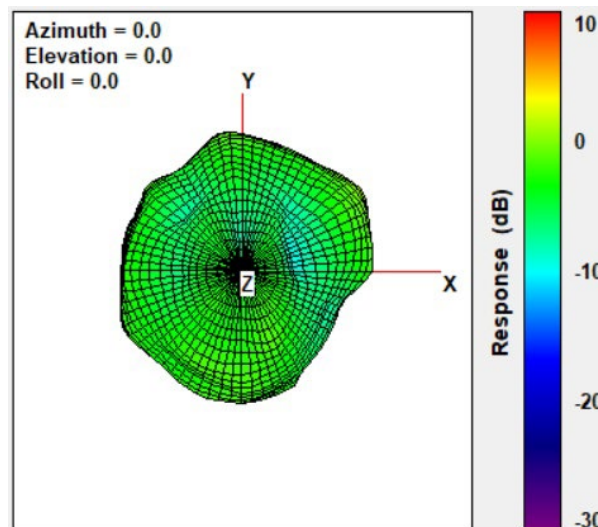

### Max Antenna 3D Radiation Pattern 5925-6425 MHz

Frequency (MHz)	Peak Gain w/ Cable Loss (dBi)
5925-6425	4.35

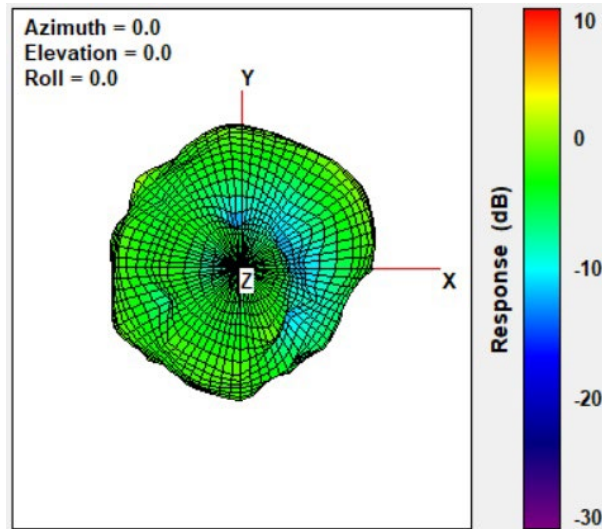

### Max Antenna 3D Radiation Pattern 6425-6525 MHz

Frequency (MHz)	Peak Gain w/ Cable Loss (dBi)
6425-6525	3.74

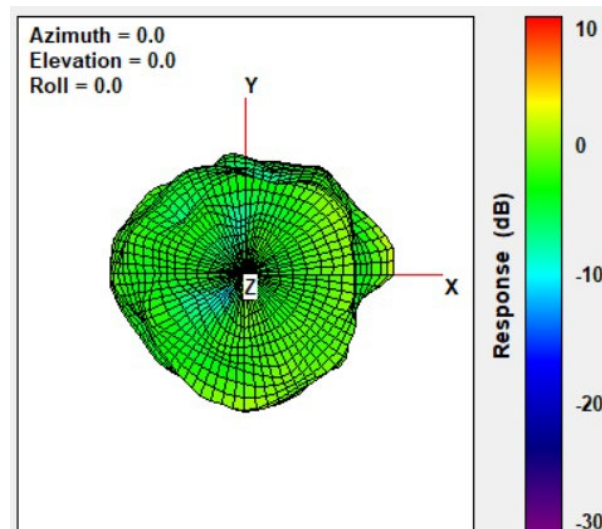



### Max Antenna 3D Radiation Pattern 6525-6875 MHz

Frequency (MHz)	Peak Gain w/ Cable Loss (dBi)
6525-6875	3.74

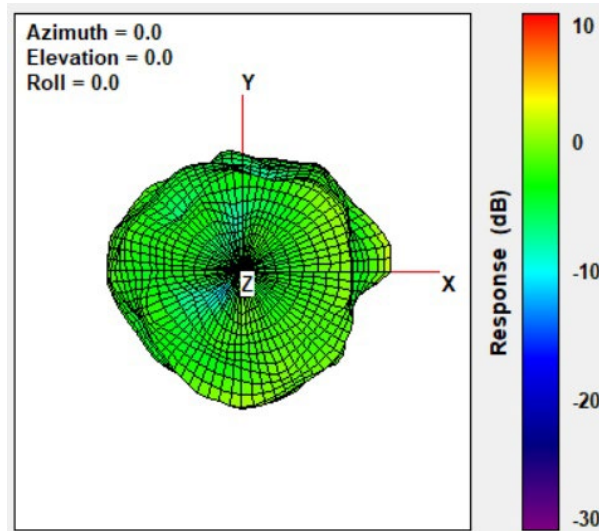

### Max Antenna 3D Radiation Pattern 6875-7125 MHz

Frequency (MHz)	Peak Gain w/ Cable Loss (dBi)
6875-7125	3.05

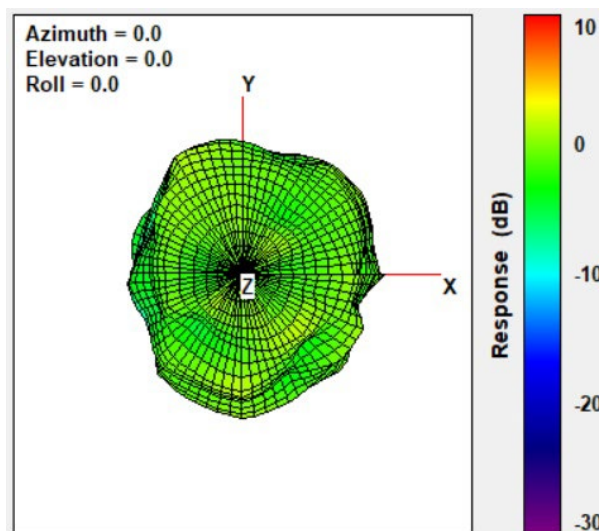

# Annex A. Photographs

---

## A.1 Setup Photo

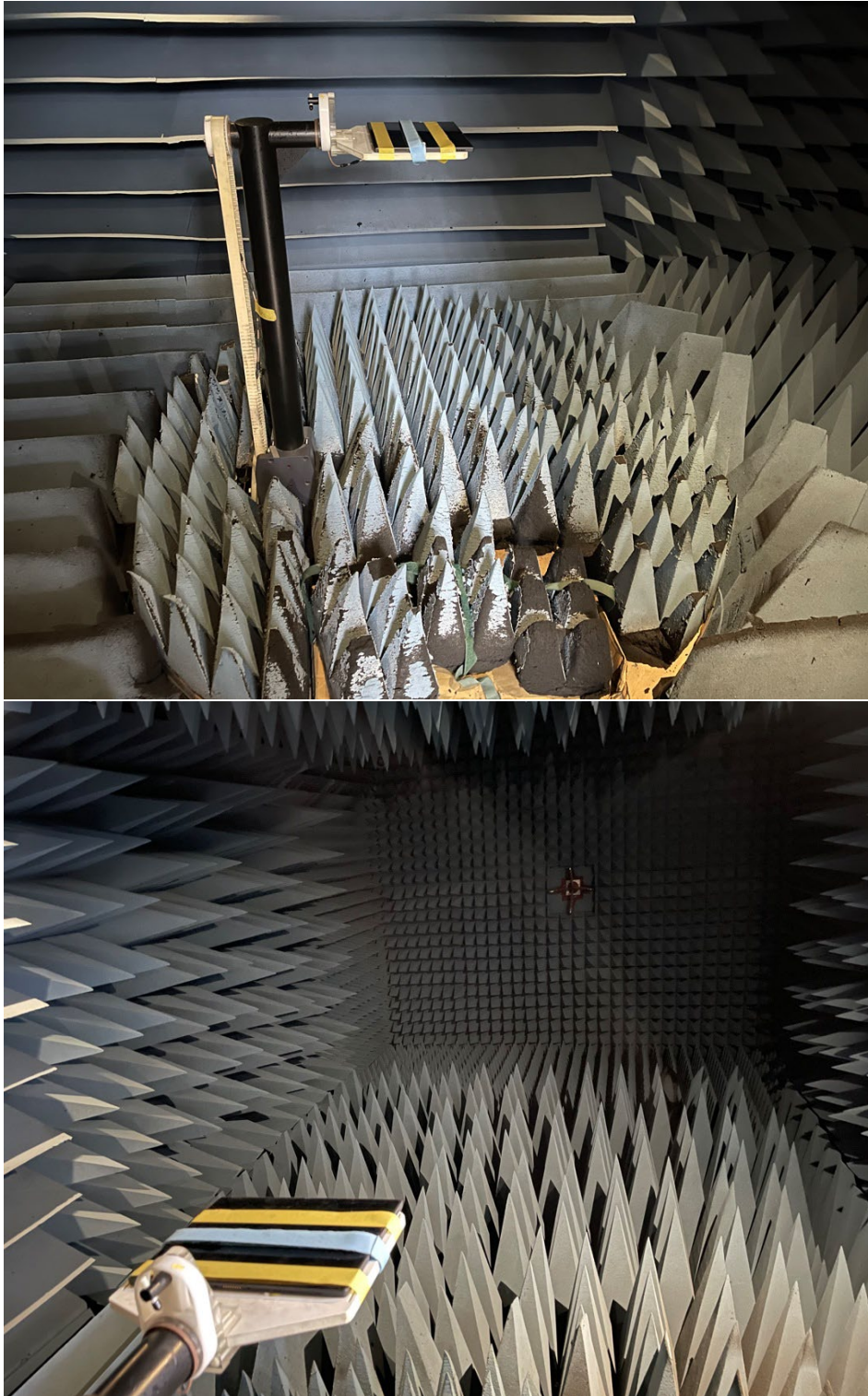

## A.2 Test sample

### Main Antenna

#### Antenna Drawing

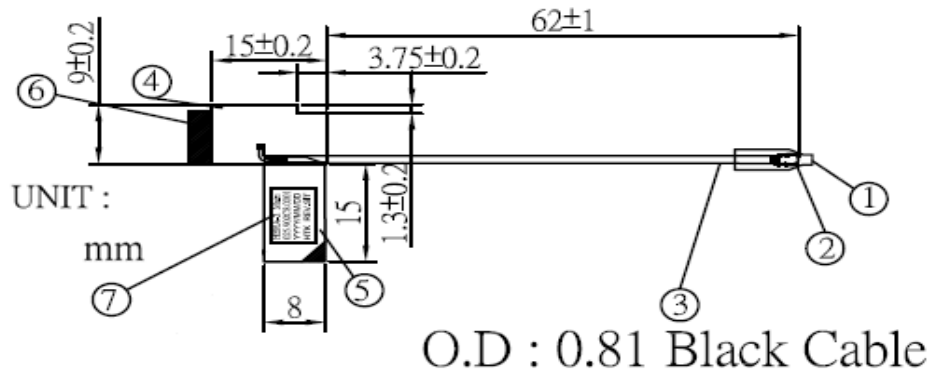

#### Antenna Photo

##### Front

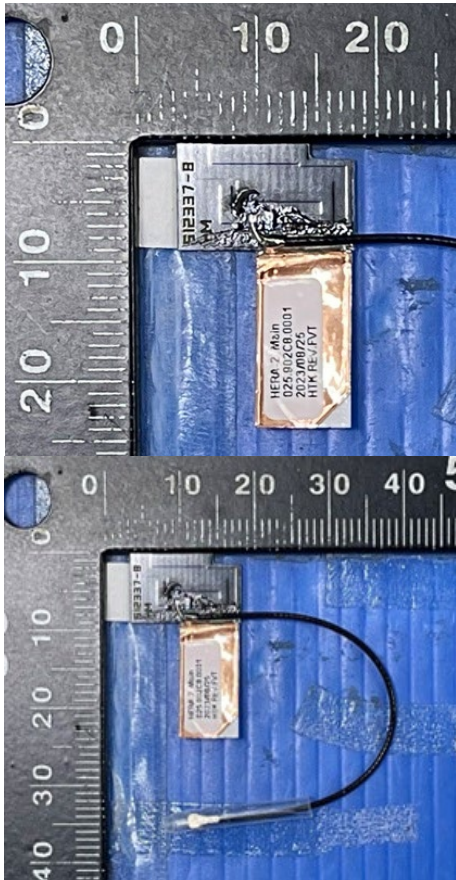

##### Back

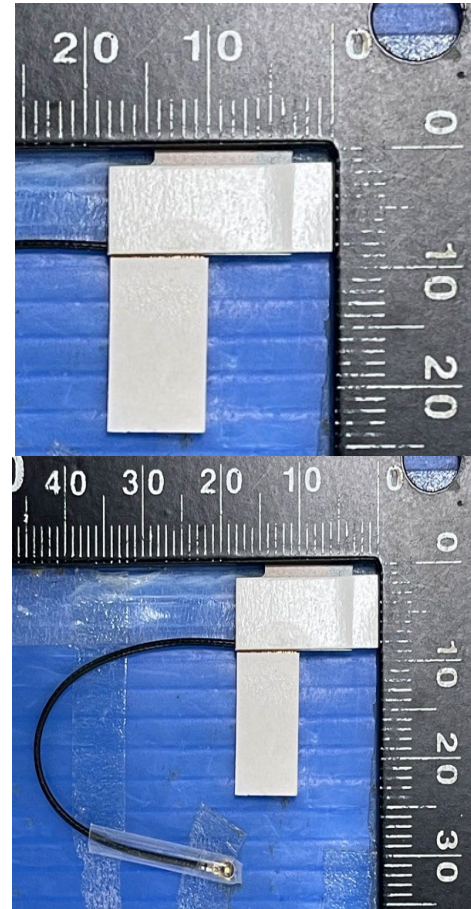

## Aux Antenna

### Antenna Drawing

O.D : 1.13 Yellow Cable

UNIT :  
mm

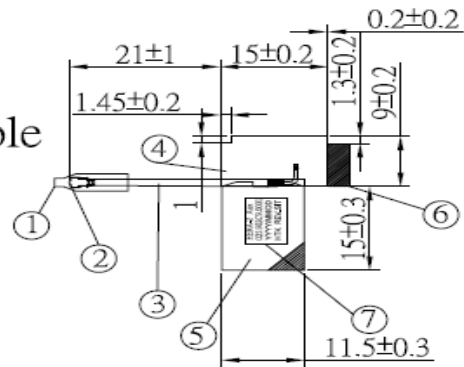

### Antenna Photo

Front

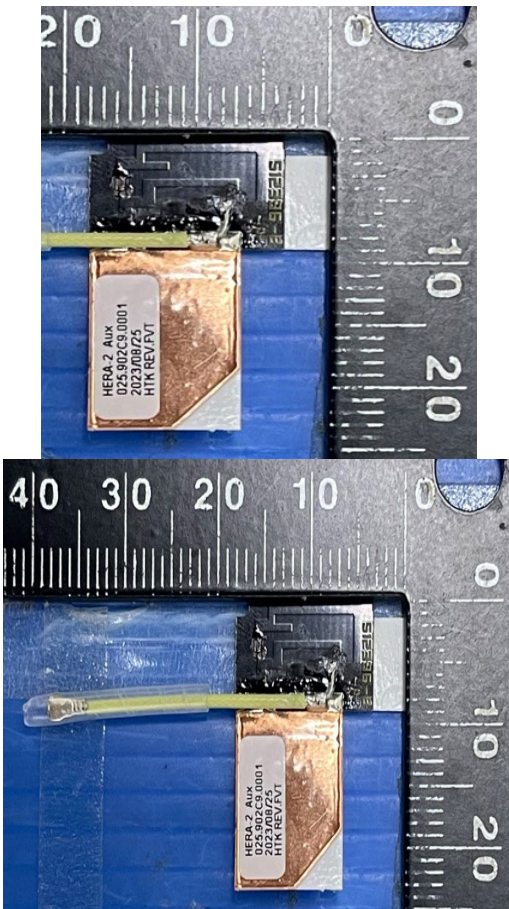

Back

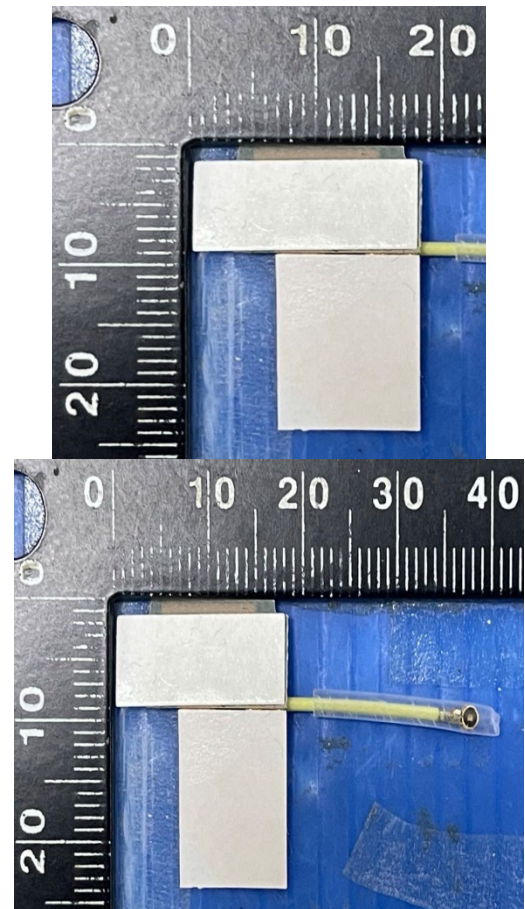

# Annex B. Antenna Location

## B.1 Antenna Host Platform Location Information

Include a dimensioned photo(s) or dimensioned drawing(s) of Main and Aux antenna placements (measurements are not required for receive-only antenna).

Any antenna that transmits must show dimensions to bottom of laptop. Provide a description of the materials that are used for supporting or surrounding transmit antennas; for example, non-conductive plastics vs. conductive coated plastic or metallic materials.

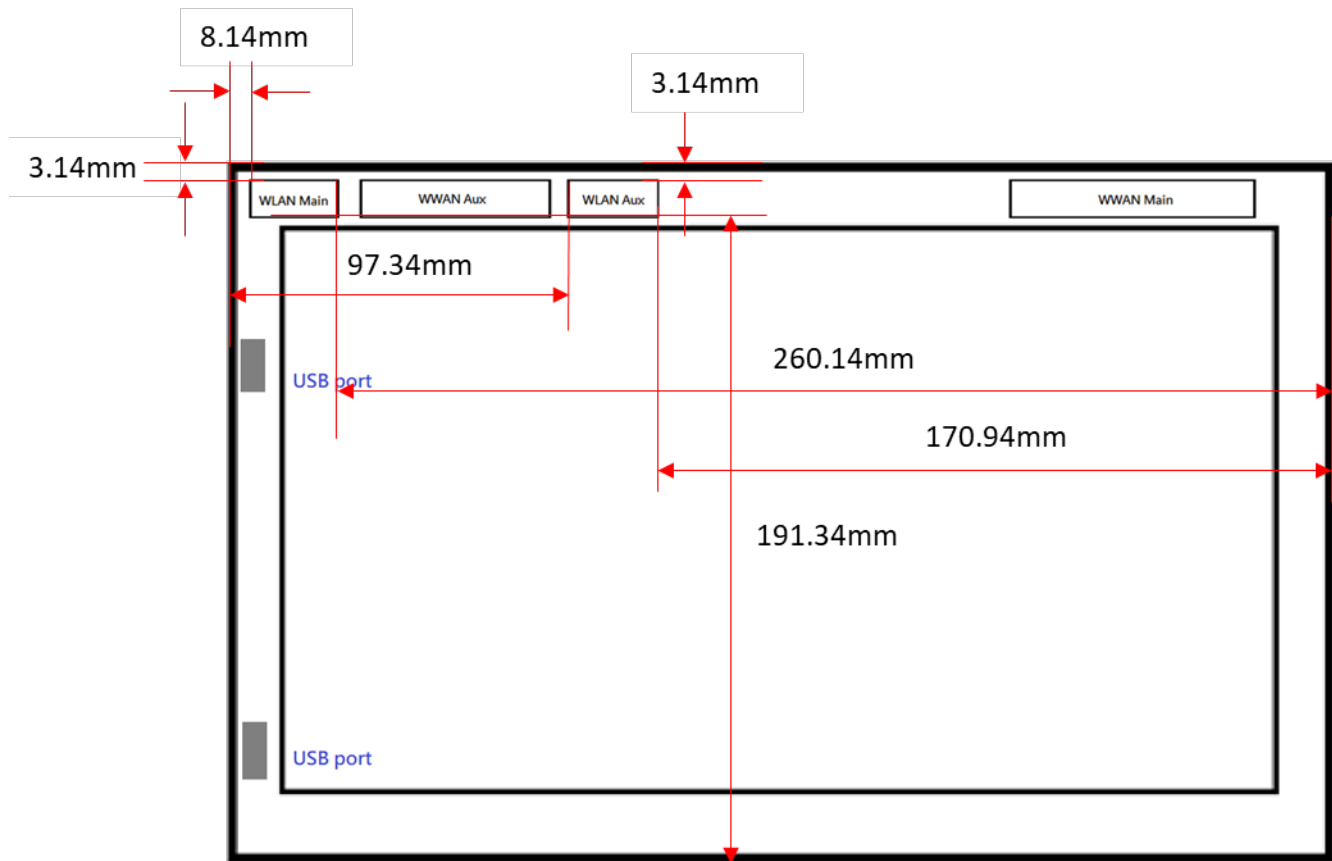

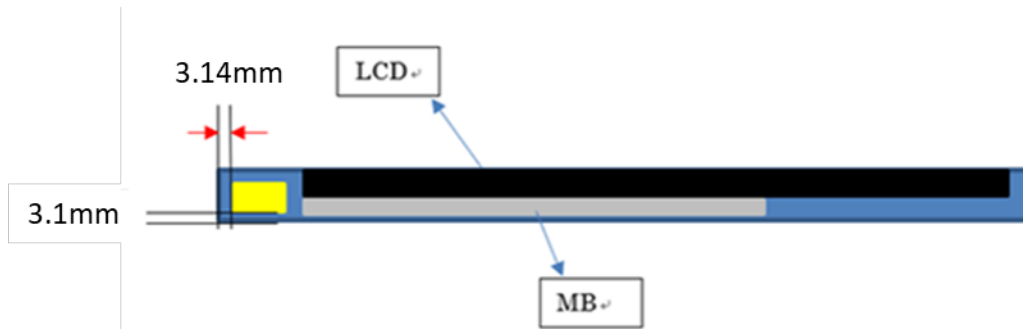
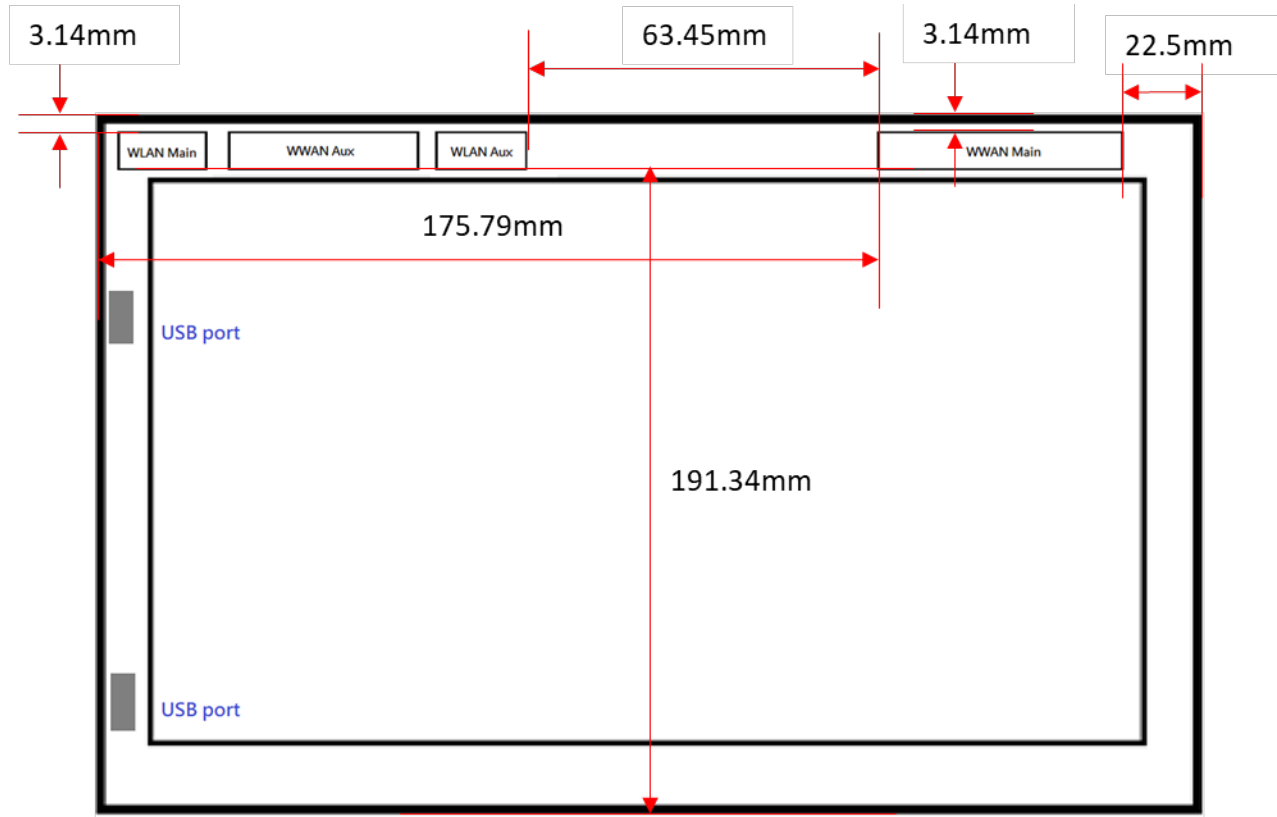

## B.2 Antenna dimensional information for SAR evaluation

Include a dimensioned photo(s) or dimensioned drawing(s) showing the distance (mm) between the transmit antennas and the user. For notebook/laptop hosts show lapheld position (example below). For tablet hosts show all orientations including lapheld, primary & secondary portrait, primary & secondary landscape positions. Include a description of any proximity sensors or power throttling implementations that limit or exclude use of any host orientation.

