

TEST REPORT

COMPLIANCE TEST REPORT

EUT Description	Convertible PC
Brand Name	HP
Model Name	HSN-C05C
FCC ID	PD9AX201D2
Date of Test Start/End	2021-10-06 / 2021-10-11
Features	IEEE802.11b/g/n/ac

Applicant	Intel Mobile Communications
Address	100 Center Point Circle, Suite 200 Columbia, South Carolina 29210 USA
Contact Person	Steven Hackett
Telephone/Fax/ Email	steven.c.hackett@intel.com

Test Report identification	220329-01.TR01
Revision Control	Rev. 00 This test report replaces any previous versions of this test report (see Section 1)

Table of Contents

1. Table of Contents	
2. Document Revision History	3
3. Test Setup	3
4. Test Sample	4
5. Test Equipment List	4
6. Test Results	4
6.1. TX POWER TABLE ASSIGNMENT	4
6.2. LID ANGLE DETECTION	5
7. Conclusion	9

2. Document Revision History

Revision #	Date	Modified by	Revision Details
Rev.00	2022-04-13	Estelle GILLES	First Issue

3. Test Setup

The conducted power measurement test setup is described in the following and illustrated in Figure A.1.

- The DUT which AX211 WiFi module is installed inside convertible PC from HP model HSN-C05C.
- A control PC is used to configure the Call Box as an access point to manage the uplink and downlink data traffic.
- Uplink signal power is measured with the Spectrum Analyzer and record by the PC with a maximum time resolution of 0.3333 msec.
- Uplink signal from the module is fed through a 3 dB Power Splitter, which delivers an equal amount of signal to the Spectrum Analyzer and the Call Box. The Splitter has high isolation between the Spectrum Analyzer and the Call Box.
- Path loss in the power measurement setup from the AX211 Antenna port to either the Call Box or the Spectrum Analyzer for 2.4 GHz and 5 GHz are 8.5 dB and 9.5 dB respectively.

Figure.1 – Validation using conducted power measurement test setup.

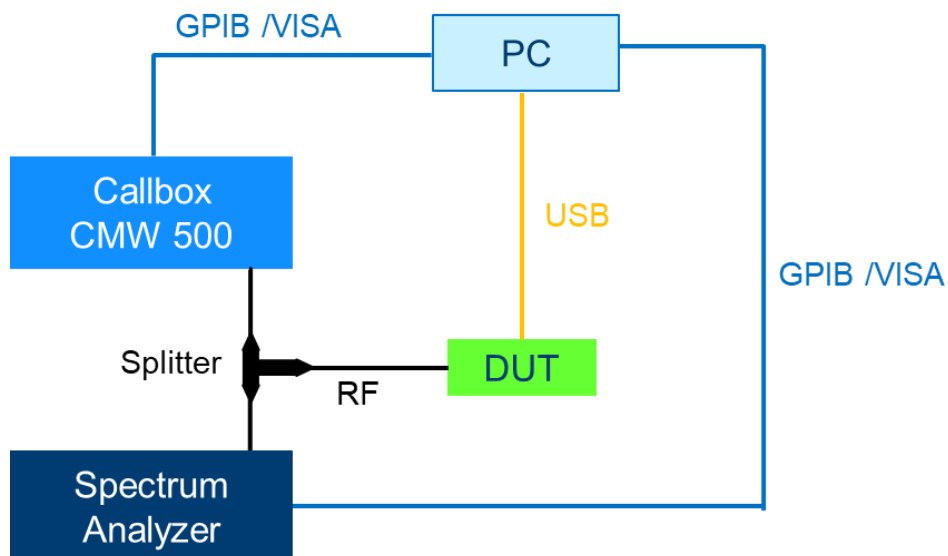

4. Test Sample

Sample	ID #	Description	Model	Serial #	Note
#1	200316-01.S01	Convertible PC	HSN-C05C	002004Y	-

5. Test Equipment List

Equipment and accessories used for the conducted power measurement test setup are listed below. The Test Platform (DUT), test setup and associated equipment are shown in A.1.3.

ID#	Device	Type/Model	Serial #	Manufacturer	Cal. Date	Cal. Due Date
025-005	Communication Tester	CMW500	161493	Rohde & Schwarz	N/A	N/A
263-000	Spectrum Analyzer	FSL6	102064	Rohde & Schwarz	2020-04-07	2022-04-07

6. Test Results

6.1. Tx Power Table Assignment

Device Status	Device Mode	Lid Angle	LCD Direction	Bios Table Index	Band	Bios Tx Power Table (dBm)		Reported Tx Power Table (dBm)		Measured Tx Power Table (dBm)		Verdict
						Chain A	Chain B	Chain A	Chain B	Chain A	Chain B	
On Table	Lid Closed	0 - 20°	-	1	2.4 GHz	17.5	18.5	17.5	18.5	17.54	18.02	Matched
					5.0 GHz	14.5	15.5	14.5	15.5	14.98	15.36	Matched
	Clamshell	20 - 180°	-	2	2.4 GHz	19.5	19.5	19.5	19.5	19.38	19.55	Matched
					5.0 GHz	19.5	19.5	19.5	19.5	19.32	19.33	Matched
	Tent	180 - 350°	Up	2	2.4 GHz	19.5	19.5	19.5	19.5	19.29	19.60	Matched
					5.0 GHz	19.5	19.5	19.5	19.5	19.30	19.21	Matched
	Stand	180 - 350°	Down	2	2.4 GHz	19.5	19.5	19.5	19.5	19.19	19.56	Matched
					5.0 GHz	19.5	19.5	19.5	19.5	19.22	19.23	Matched
	Tablet	350 - 360°	-	2	2.4 GHz	19.5	19.5	19.5	19.5	19.17	19.56	Matched
					5.0 GHz	19.5	19.5	19.5	19.5	19.21	19.03	Matched
Not On Table	Lid Closed	0 - 20°	-	1	2.4 GHz	17.5	18.5	17.5	18.5	17.47	18.00	Matched
					5.0 GHz	14.5	15.5	14.5	15.5	14.95	15.39	Matched
	Clamshell	20 - 180°	-	2	2.4 GHz	19.5	19.5	19.5	19.5	19.35	19.55	Matched
					5.0 GHz	19.5	19.5	19.5	19.5	19.37	19.28	Matched
	Tent	180 - 350°	Up	1	2.4 GHz	17.5	18.5	17.5	18.5	17.29	18.04	Matched
					5.0 GHz	14.5	15.5	14.5	15.5	14.80	15.35	Matched
	Stand	180 - 350°	Down	2	2.4 GHz	19.5	19.5	19.5	19.5	19.33	19.59	Matched
					5.0 GHz	19.5	19.5	19.5	19.5	19.25	19.15	Matched
	Tablet	350 - 360°	-	1	2.4 GHz	17.5	18.5	17.5	18.5	17.16	18.07	Matched
					5.0 GHz	14.5	15.5	14.5	15.5	14.83	15.23	Matched

6.2. Lid Angle Detection

Step 1 – Open Screen with 10 degrees step

Starting Point Mode Laptop						Starting Point Mode Tablet					
Angle	2.4GHz	Device Mode	Angle	5 GHz	Device Mode	Angle	2.4GHz	Device Mode	Angle	5 GHz	Device Mode
0	17.55	Lid Closed	0	14.41	Lid Closed	360	17.26	Tablet	360	14.52	Tablet
10	17.53	Lid Closed	10	14.47	Lid Closed	350	17.18	Tablet	350	14.56	Tablet
20	17.52	Lid Closed	20	14.36	Lid Closed	340	19.11	Stand	340	14.30	Tablet
30	19.43	Clamshell	30	19.09	Clamshell	330	-	-	330	19.09	Stand

Step 2 – Close Screen with 5 degrees step

Starting Point Mode Laptop						Starting Point Mode Tablet					
Angle	2.4GHz	Device Mode	Angle	5 GHz	Device Mode	Angle	2.4GHz	Device Mode	Angle	5 GHz	Device Mode
25	19.4	Clamshell	25	19.02	Clamshell	345	19.18	Stand	335	19.05	Stand
20	19.30	Clamshell	20	19.07	Clamshell	350	19.15	Stand	340	19.09	Stand
15	19.12	Clamshell	15	19.11	Clamshell	355	17.02	Tablet	345	19.13	Stand
10	17.34	Lid Closed	10	14.56	Lid Closed	-	-	-	350	19.10	Stand

Step 3 – Open Screen with 1 degree step

Starting Point Mode Laptop						Starting Point Mode Tablet					
Angle	2.4GHz	Device Mode	Angle	5 GHz	Device Mode	Angle	2.4GHz	Device Mode	Angle	5 GHz	Device Mode
11	17.61	Lid Closed	11	14.49	Lid Closed	354	17.10	Tablet	354	14.41	Tablet
12	17.54	Lid Closed	12	14.20	Lid Closed	353	17.09	Tablet	353	14.26	Tablet
13	17.52	Lid Closed	13	14.43	Lid Closed	352	17.08	Tablet	352	14.37	Tablet
14	17.56	Lid Closed	14	14.51	Lid Closed	351	17.09	Tablet	351	14.39	Tablet
15	17.52	Lid Closed	15	14.41	Lid Closed	350	17.11	Tablet	350	14.34	Tablet
16	17.53	Lid Closed	16	14.49	Lid Closed	349	17.16	Tablet	349	14.25	Tablet
17	17.53	Lid Closed	17	14.51	Lid Closed	348	17.12	Tablet	348	14.31	Tablet
18	17.5	Lid Closed	18	14.47	Lid Closed	347	17.14	Tablet	347	14.33	Tablet
19	17.64	Lid Closed	19	14.48	Lid Closed	346	17.14	Tablet	346	14.30	Tablet
20	17.4	Lid Closed	20	14.45	Lid Closed	345	17.14	Tablet	345	14.02	Tablet
21	17.57	Lid Closed	21	14.48	Lid Closed	344	17.13	Tablet	344	14.09	Tablet
22	17.65	Lid Closed	22	14.49	Lid Closed	343	17.13	Tablet	343	14.32	Tablet
23	17.67	Lid Closed	23	14.42	Lid Closed	342	17.14	Tablet	342	14.25	Tablet
24	17.7	Lid Closed	24	14.58	Lid Closed	341	17.14	Tablet	341	19.05	Stand
25	17.67	Lid Closed	25	14.37	Lid Closed	340	17.11	Tablet	340	19.02	Stand
26	19.53	Clamshell	26	14.49	Lid Closed	339	19.33	Stand	339	19.05	Stand
27	19.09	Clamshell	27	14.46	Lid Closed	338	19.08	Stand	338	19.02	Stand
28	19.02	Clamshell	28	14.38	Lid Closed	337	19.17	Stand	337	19.05	Stand
29	19.11	Clamshell	29	14.48	Lid Closed	336	19.12	Stand	336	19.06	Stand
30	19.08	Clamshell	30	19.08	Clamshell	335	19.10	Stand	-	-	-
31	19.49	19.01	31	19.01	Clamshell	334	19.18	Stand	-	-	-
-	-	-	32	19.05	Clamshell	-	-	-	-	-	-
-	-	-	33	19.12	Clamshell	-	-	-	-	-	-
-	-	-	34	19.05	Clamshell	-	-	-	-	-	-

Step 4 – Open Screen with 10 degrees step

Starting Point Mode Laptop						Starting Point Mode Tablet					
Angle	2.4GHz	Device Mode	Angle	5 GHz	Device Mode	Angle	2.4GHz	Device Mode	Angle	5 GHz	Device Mode
41	19.41	Clamshell	45	19.07	Clamshell	324	19.07	Stand	336	19.06	Stand
51	19.38	Clamshell	55	19.13	Clamshell	314	19.10	Stand	326	19.08	Stand
61	19.39	Clamshell	65	19.07	Clamshell	304	19.18	Stand	316	19.01	Stand
71	19.41	Clamshell	75	19.08	Clamshell	294	19.33	Stand	306	19.12	Stand
81	19.43	Clamshell	85	19.20	Clamshell	284	19.24	Stand	296	19.02	Stand
91	19.40	Clamshell	95	19.14	Clamshell	274	19.19	Stand	286	19.05	Stand
101	19.38	Clamshell	105	19.11	Clamshell	264	19.41	Stand	276	19.08	Stand
111	19.48	Clamshell	115	19.08	Clamshell	254	19.27	Stand	266	19.05	Stand
121	19.43	Clamshell	125	19.13	Clamshell	244	19.26	Stand	256	19.03	Stand
131	19.30	Clamshell	135	19.09	Clamshell	234	19.30	Stand	246	19.03	Stand
141	19.37	Clamshell	145	19.17	Clamshell	224	19.28	Stand	236	19.02	Stand
151	19.34	Clamshell	155	19.05	Clamshell	214	19.15	Stand	226	19.05	Stand
161	19.41	Clamshell	165	19.06	Clamshell	204	19.05	Stand	216	19.07	Stand
171	19.43	Clamshell	175	19.02	Clamshell	194	19.17	Stand	206	19.02	Stand
181	19.29	Stand	185	19	Stand	184	19.07	Clamshell	196	19.03	Stand
191	19.48	Stand	195	19.01	Stand	174	19.30	Clamshell	186	19.11	Clamshell
201	19.13	Stand	205	19.04	Stand	164	19.34	Clamshell	176	19.04	Clamshell
211	19.3	Stand	215	19.11	Stand	154	19.31	Clamshell	166	19.09	Clamshell
221	19.29	Stand	225	19.07	Stand	144	19.14	Clamshell	156	19.11	Clamshell
231	19.10	Stand	235	19.07	Stand	134	19.51	Clamshell	146	19	Clamshell
241	19.04	Stand	245	19.14	Stand	124	19.20	Clamshell	136	19.03	Clamshell
251	19.04	Stand	255	19.12	Stand	114	19.27	Clamshell	126	19.02	Clamshell
261	19.06	Stand	265	19.07	Stand	104	19.30	Clamshell	116	19.10	Clamshell
271	19.12	Stand	275	19.08	Stand	94	19.35	Clamshell	106	19.05	Clamshell

Test Report No: 220329-01.TR01

281	19	Stand	285	19	Stand	84	19.01	Clamshell	96	19	Clamshell
291	19.30	Stand	295	19.02	Stand	74	19.10	Clamshell	86	19.04	Clamshell
301	19.22	Stand	305	19.01	Stand	64	19.04	Clamshell	76	19.01	Clamshell
311	19.37	Stand	315	19.05	Stand	54	19.13	Clamshell	66	19.13	Clamshell
321	19.11	Stand	325	19.02	Stand	44	19.29	Clamshell	56	19.06	Clamshell
331	19.07	Stand	335	19.10	Stand	34	19.13	Clamshell	46	19.01	Clamshell
341	19.12	Stand	345	19.09	Stand	24	19.12	Clamshell	36	19.01	Clamshell
351	17.21	Tablet	355	14.57	Tablet	14	17.36	Lid closed	26	19.03	Clamshell
360	17.12	Tablet	360	14.56	Tablet	0	17.31	Lid closed	16	14.29	Lid closed
-	-		-	-		-	-		0	14.25	Lid closed

7. Conclusion

The Smart Switch functionality of AX201 WiFi Module Integrated inside HP HSN-C05C is tested. All user cases are compliant.