

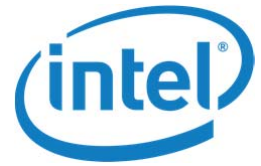

TESTING CERT #3478.01



# TEST REPORT

|                           |  |
|---------------------------|--|
| EUT Description           | <b>GSM, W-CDMA and LTE Cellular adapter card</b>   |
| Brand Name                | <b>Intel</b>   |
| Model Name                | <b>7262M2WW</b>  |
| Serial Number             | <b>IMEI: 004402523024945 / 004402523014110 / 004402523024556/<br/>004402523013260 / 004402523023640</b><br>(see section 4)                                   |
| FCC/IC ID                 | <b>FCC ID: PD97262WW / IC ID: 1000M-7262WW</b>   |
| Antenna type              | <b>Dipole, Pulse, Part Number SPDA24700/2700</b>   |
| Hardware/Software Version | <b>HW PR2.1, SW 1449</b>   |
| Date of Sample Receipt    | <b>2014-11-25</b>  |
| End of Test Date          | <b>2014-03-17</b>  |
| Features                  | <b>2G: GSM/GPRS/EDGE 850 / 1900<br/>3G: WCDMA/HSPA/DC-HSDPA FDD II / IV / V<br/>4G: LTE-FDD 2, 4, 5, 7, 12, 13, 17, 26<br/>LTE-TDD 41</b><br>(see section 5) |

|                      |  |
|----------------------|--|
| Applicant            | <b>Intel Mobile Communication</b>  |
| Address              | <b>“Le Navigator” BatB<br/>505 route des Lucioles<br/>06560 Valbonne – Sophia Antipolis<br/>France</b> |
| Contact Person       | <b>Wilfrid D’Angelo</b>  |
| Telephone/Fax/ Email | <b>wilfrid.dangelo@intel.com</b>   |

|                     |   |
|---------------------|---|
| Reference Standards | <b>FCC CFR Title 47 Part 2, 22, 24, 27, 90<br/>RSS 130 issue1, RSS 132 issue 3, RSS 133 issue 6, RSS 139 issue 2,<br/>RSS 199 issue 2, RSS Gen issue 4</b><br>(see section 1) |
|---------------------|---|

|                    |                      |
|--------------------|----------------------|
| Test Report number | <b>14112501.TR07</b> |
| Revision Control   | <b>Rev. 00</b>       |

The test results relate only to the samples tested.  
The test report shall not be reproduced in full, without written approval of the laboratory.

\_\_\_\_\_ Issued by \_\_\_\_\_ Reviewed by \_\_\_\_\_ Approved by \_\_\_\_\_

Olivier FARGANT  
(Test Operator)

Jose M. FORTES  
(Technical Manager)

Nawfal ASRIH  
(Laboratory Manager)

**Intel Mobile Communications France S.A.S – WRF Lab  
425 rue de Goa – Le Cargo B6 – Z.I. des 3 Moulins – 06600, Antibes, France  
Tel. +33493001400 / Fax +33493001401**

# Table of Contents

---

|  |            |
|--|------------|
| <b>1. Standards, reference documents and applicable test methods .....</b> | <b>3</b>   |
| <b>2. General conditions, competences and guarantees .....</b>             | <b>3</b>   |
| <b>3. Environmental Conditions .....</b>                                   | <b>4</b>   |
| <b>4. Test samples.....</b>  | <b>4</b>   |
| <b>5. EUT features .....</b>   | <b>5</b>   |
| <b>6. Remarks and comments .....</b>                                       | <b>6</b>   |
| <b>7. Test Verdicts summary .....</b>                                      | <b>6</b>   |
| <b>8. Document Revision History .....</b>                                  | <b>9</b>   |
| <b>Annex A. Test &amp; System Description .....</b>                        | <b>10</b>  |
| MEASUREMENT SYSTEM.....  | 10         |
| TEST EQUIPMENT LIST .....  | 12         |
| MEASUREMENT UNCERTAINTY EVALUATION.....                                    | 12         |
| <b>Annex A. Test Results .....</b>   | <b>13</b>  |
| TEST CONDITIONS.....   | 13         |
| TEST RESULTS .....   | 13         |
| A.1.1 Conducted RF output power.....                                       | 13         |
| A.1.2 Occupied bandwidth.....  | 33         |
| A.1.3 Peak to average ratio.....   | 268        |
| A.1.4 Conducted band-edge and spurious emission.....                       | 273        |
| A.1.5 Radiated spurious emission.....                                      | 459        |
| <b>Annex B. Subcontracted Test Results .....</b>                           | <b>470</b> |
| B.1.1 Frequency stability over temperature variations.....                 | 470        |
| B.1.2 Frequency stability over voltage variations.....                     | 475        |
| <b>Annex C. Spot Check.....</b>  | <b>478</b> |
| C.1.1 Conducted RF output power.....                                       | 478        |
| C.1.2 Occupied bandwidth.....  | 483        |
| C.1.3 Peak to average ratio.....   | 484        |
| C.1.4 Conducted band-edge and spurious emission.....                       | 486        |
| <b>Annex D. Photographs .....</b>  | <b>545</b> |

## 1. Standards, reference documents and applicable test methods

1. FCC 47 CFR part 2 – Subpart J - EQUIPMENT AUTHORIZATION PROCEDURES.
2. FCC 47 CFR part 22 – Subpart H - Cellular Radiotelephone Service.
3. FCC 47 CFR part 24 – Subpart E - Broadband PCS.
4. FCC 47 CFR part 27 – Subpart L – 1695 - 1710, 1710 - 1755 MHz, 1755 - 1780 MHz, 2110 - 2155 MHz, 2155 - 2180 MHz, 2180-2200 MHz Bands.
5. FCC OET KDB 971168 D01 v02r02 Measurement guidance for certification of licensed digital transmitters.
6. FCC OET KDB 971168 D01 v02r02 Measurement guidance for certification of licensed digital transmitters.
7. RSS-Gen – General Requirements for Compliance of Radio Apparatus.
8. RSS130 issue 1 – Mobile Broadband Services (MBS) Equipment Operating in the Frequency Bands 698 - 756 MHz and 777 - 787 MHz
9. RSS 132 issue 3 – Cellular Telephone Systems Operating in the Bands 824-849 MHz and 869-894 MHz.
10. RSS 133 issue 6 – 2 GHz Personal Communications Services.
11. RSS 139 issue 2 – Advanced Wireless Services Equipment Operating in the Bands 1710 - 1755 MHz and 2110 - 2155 MHz.
12. RSS-199 – Broadband Radio Service (BRS) Equipment Operating in the Band 2500 - 2690 MHz.
13. TIA 603 – D June 2010 Land Mobile FM or PM Communications Equipment Measurement and Performance Standards.
14. ANSI C63.4-2009 – American National Standard for Methods of Measurement of Radio-Noise Emissions from Low-Voltage Electrical and Electronic Equipment in the Range of 9 kHz to 40 GHz.

## 2. General conditions, competences and guarantees

- ✓ Intel Mobile Communications Wireless RF Lab (Intel WRF Lab) is a testing laboratory accredited by the American Association for Laboratory Accreditation (A2LA).
- ✓ Intel Mobile Communications Wireless RF Lab (Intel WRF Lab) is an Accredited Test Firm listed by the FCC, with Designation Number FR0011.
- ✓ Intel Mobile Communications Wireless RF Lab (Intel WRF Lab) is a Registered Test Site listed by IC, with IC Assigned Code 1000Y.
- ✓ Intel WRF Lab only provides testing services and is committed to providing reliable, unbiased test results and interpretations.
- ✓ Intel WRF Lab is liable to the client for the maintenance of the confidentiality of all information related to the item under test and the results of the test.
- ✓ Intel WRF Lab has developed calibration and proficiency programs for its measurement equipment to ensure correlated and reliable results to its customers.
- ✓ This report is only referred to the item that has undergone the test.
- ✓ This report does not imply an approval of the product by the Certification Bodies or competent Authorities.
- ✓ Complete or partial reproduction of the report cannot be made without written permission of Intel WRF Lab.

### 3. Environmental Conditions

- ✓ At the site where the measurements were performed the following limits were not exceeded during the tests:

|             |            |
|-------------|------------|
| Temperature | 22°C ± 2°C |
| Humidity    | 45% ± 8%   |

### 4. Test samples

| Sample | Control #    | Description | Model                      | Serial #        | Date of reception | Note   |
|--------|--------------|-------------|----------------------------|-----------------|-------------------|--|
| #01    | 14112501.S05 | Module      | 7262M2WW                   | 004402523024945 | 2015-01-12        | Used for conducted tests                             |
|        | 14112501.S10 | Module      | 7262M2WW                   | 004402523014110 | 2015-02-10        |  |
|        | 14112401.S09 | Extender    | NGFF Carrier board Rev 1.1 | NA              | 2014-11-25        |  |
| #02    | 14112401.S04 | Module      | 7262M2WW                   | 004402523024556 | 2014-11-24        | Used for radiated tests                              |
|        | 14112401.S07 | Antenna     | Pulse SPDA24700/2700       | NA              | 2014-11-24        |  |
|        | 14112401.S08 | Antenna     | Pulse SPDA24700/2700       | NA              | 2014-11-24        |  |
| #04    | 15021011.S11 | Module      | 7262M2WW                   | 004402523013260 | 2015-02-10        | Used for radiated tests                              |
|        | 14112401.S07 | Antenna     | Pulse SPDA24700/2700       | NA              | 2014-11-24        |  |
|        | 14112401.S08 | Antenna     | Pulse SPDA24700/2700       | NA              | 2014-11-24        |  |
| #05    | 44937/001    | Module      | 7262M2WW                   | 004402523023640 | 2015-01-21        | Used for subcontracted results (Frequency stability) |
|        | 43903B/001   | Extender    | NGFF Carrier board Rev 2.0 | NA              | 2014-09-30        |  |

NA: Not Applicable

## 5. EUT features

These are the detailed bands and modes supported by the Equipment Under Test:

|                   |  |
|-------------------|--|
| GSM / GPRS / EDGE | GSM 850 (824.0 – 849.0 MHz)<br>PCS 1900 (1850.0 – 1910.0 MHz)  |
| WCDMA / HSPA+     | FDD II (1850.0 – 1910.0 MHz)<br>FDD IV (1710.0 – 1755.0 MHz)<br>FDD V (824.0 – 849.0 MHz)  |
| LTE FDD           | Band 2 (1850.0 – 1910.0 MHz)<br>Band 4 (1710.0 – 1755.0 MHz)<br>Band 5 (824.0 – 849.0 MHz)<br>Band 7 (2500 – 2570 MHz)<br>Band 12 (699 – 716 MHz)<br>Band 13 (777 – 787 MHz)<br>Band 17 (704.0 – 716.0 MHz)<br>Band 26 (814 – 849 MHz) |
| LTE TDD           | Band 41 (2496 – 2690 MHz)  |

### Emission designator for IC cert:

#### LTE emission designator

| Band                          | Type of modulation |          |
|-------------------------------|--------------------|----------|
|                               | QPSK               | 16QAM    |
| LTE Band 2, Bandwidth 1.4MHz  | 1M11G7D            | 1M11W7D  |
| LTE Band 2, Bandwidth 3MHz    | 2M73G7D            | 2M74W7D  |
| LTE Band 2, Bandwidth 5MHz    | 4M52G7D            | 4M52W7D  |
| LTE Band 2, Bandwidth 10MHz   | 9M04G7D            | 9M04W7D  |
| LTE Band 2, Bandwidth 15MHz   | 13M5G7D            | 13M5W7D  |
| LTE Band 2, Bandwidth 20MHz   | 17M92G7D           | 17M91W7D |
| LTE Band 4, Bandwidth 1.4MHz  | 1M11G7D            | 1M11W7D  |
| LTE Band 4, Bandwidth 3MHz    | 2M73G7D            | 2M72W7D  |
| LTE Band 4, Bandwidth 5MHz    | 4M53G7D            | 4M51W7D  |
| LTE Band 4, Bandwidth 10MHz   | 9M04G7D            | 9M02W7D  |
| LTE Band 4, Bandwidth 15MHz   | 13M57G7D           | 13M51W7D |
| LTE Band 4, Bandwidth 20MHz   | 17M87G7D           | 17M9W7D  |
| LTE Band 5, Bandwidth 1.4MHz  | 1M10G7D            | 1M10W7D  |
| LTE Band 5, Bandwidth 3MHz    | 2M74G7D            | 2M73W7D  |
| LTE Band 5, Bandwidth 5MHz    | 4M51G7D            | 4M51W7D  |
| LTE Band 5, Bandwidth 10MHz   | 9M04G7D            | 9M03W7D  |
| LTE Band 12, Bandwidth 1.4MHz | 1M11G7D            | 1M10W7D  |
| LTE Band 12, Bandwidth 3MHz   | 2M74G7D            | 2M73W7D  |
| LTE Band 12, Bandwidth 5MHz   | 4M50G7D            | 4M51W7D  |
| LTE Band 12, Bandwidth 10MHz  | 9M03G7D            | 9M04W7D  |

| Band                          | Type of modulation |          |
|-------------------------------|--------------------|----------|
|                               | QPSK               | 16QAM    |
| LTE Band 17, Bandwidth 5MHz   | 4M52G7D            | 4M54W7D  |
| LTE Band 17, Bandwidth 10MHz  | 9M05G7D            | 9M02W7D  |
| LTE Band 13, Bandwidth 5MHz   | 4M51G7D            | 4M51W7D  |
| LTE Band 13, Bandwidth 10MHz  | 8M99G7D            | 8M98W7D  |
| LTE Band 26, Bandwidth 1.4MHz | 1M10G7D            | 1M10W7D  |
| LTE Band 26, Bandwidth 3MHz   | 2M72G7D            | 2M73W7D  |
| LTE Band 26, Bandwidth 5MHz   | 4M51G7D            | 4M52W7D  |
| LTE Band 26, Bandwidth 10MHz  | 9M05G7D            | 9M04W7D  |
| LTE Band 26, Bandwidth 15MHz  | 13M65G7D           | 13M52W7D |
| LTE Band 41, Bandwidth 5MHz   | 4M52G7D            | 4M54W7D  |
| LTE Band 41, Bandwidth 10MHz  | 9M02G7D            | 9M01W7D  |
| LTE Band 41, Bandwidth 15MHz  | 13M5G7D            | 13M5W7D  |
| LTE Band 41, Bandwidth 20MHz  | 17M9G7D            | 17M9W7D  |
| LTE Band 7, Bandwidth 5MHz    | 4M51G7D            | 4M51W7D  |
| LTE Band 7, Bandwidth 10MHz   | 9M04G7D            | 9M02W7D  |
| LTE Band 7, Bandwidth 15MHz   | 13M6G7D            | 13M5W7D  |
| LTE Band 7, Bandwidth 20MHz   | 17M9G7D            | 17M9W7D  |

## 6. Remarks and comments

1. The frequency stability test results, detailed in Annex B, were performed at AT4 wireless S.A., PTA – C/ Severo Ochoa 2, 29590, Málaga, SPAIN.
2. According to Applicants declaration, between the EUT version HW PR2.0, SW 1445 and EUT version HW PR2.1, SW 1449, there are no differences regarding the LTE band 2, 4, 5, 17. For these band only worst case found on PR2.0 are reported (Annex C). More tests results can be found on the EUT HW PR2.0, SW 1445, see test reports reference 14112501.TR01 revision 01 and 14112501.TR02 revision 01.

## 7. Test Verdicts summary

| Mode | Band | FCC part       | RSS part     | Test name                           | Verdict |
|------|------|----------------|--------------|-------------------------------------|---------|
| LTE  | 2    | 2.1046         | Gen-ch.6.12  | Conducted output power              | P       |
|      |      | 24.238         | -            | Emission bandwidth 26dB             | P       |
|      |      | 24.232         | 133-ch.6.4   | Equivalent isotropic radiated power | P       |
|      |      | 2.1049         | -            | Occupied bandwidth 99%              | P       |
|      |      | 24.232         | 133-ch.6.4   | Peak to average ratio               | P       |
|      |      | 24.235, 2.1055 | 133-ch.6.3   | Frequency Stability                 | P       |
|      |      | 24.238         | 133-ch.6.5.1 | Conducted band-edge                 | P       |
|      |      | 24.238         | 133-ch.6.5.1 | Conducted spurious emission         | P       |
|      |      | 24.238         | 133-ch.6.5.1 | Radiated spurious emission          | P       |

P: Pass  
 F: Fail  
 NM: Not Measured  
 NA: Not Applicable

| Mode | Band | FCC part       | RSS part    | Test name                           | Verdict |
|------|------|----------------|-------------|-------------------------------------|---------|
| LTE  | 4    | 2.1046         | Gen-ch.6.12 | Conducted output power              | P       |
|      |      | 27.53          | 139-ch.2.3  | Emission bandwidth 26dB             | P       |
|      |      | 27.50          | 139-ch.6.4  | Equivalent isotropic radiated power | P       |
|      |      | 2.1049         | -           | Occupied bandwidth 99%              | P       |
|      |      |                | 139-ch.6.4  | Peak to average ratio               | P       |
|      |      | 27.54, 2.1055  | 139-ch.6.3  | Frequency Stability                 | P       |
|      |      | 27.53, 2.1051  | 139-ch.6.5  | Conducted band-edge                 | P       |
|      |      | 27.53          | 139-ch.6.5  | Conducted spurious emission         | P       |
|      |      | 27.53, 2.1053  | 139-ch.6.5  | Radiated spurious emission          | P       |
| LTE  | 5    | 2.1046         | Gen-ch.6.12 | Conducted output power              | P       |
|      |      | 2.1049         | -           | Occupied bandwidth (99%)            | P       |
|      |      | 22.917         | -           | Occupied bandwidth (26dB)           | P       |
|      |      | 22.355, 2.1055 | 132-ch.5.3  | Frequency Stability                 | P       |
|      |      | 22.917, 2.1051 | 132-ch.5.5  | Band Edge conducted emission        | P       |
|      |      | 22.917, 2.1051 | 132-ch.5.5  | Spurious emission                   | P       |
|      |      | 22.913         | 132-ch.5.4  | Effective radiated power            | P       |
|      |      | 22.917, 2.1053 | 132-ch.5.5  | Radiated spurious emission          | P       |
|      |      | -              | 132-ch.5.4  | Peak-to-average power ratio         | P       |
| LTE  | 7    | 2.1046         | Gen-ch.6.12 | Conducted output power              | P       |
|      |      | 27.53          | 139-ch.2.3  | Emission bandwidth 26dB             | P       |
|      |      | 27.50          | 139-ch.6.4  | Equivalent isotropic radiated power | P       |
|      |      | 2.1049         | -           | Occupied bandwidth 99%              | P       |
|      |      | -              | 139-ch.6.4  | Peak to average ratio               | P       |
|      |      | 27.54, 2.1055  | 139-ch.6.3  | Frequency Stability                 | P       |
|      |      | 27.53, 2.1051  | 139-ch.6.5  | Conducted band-edge                 | P       |
|      |      | 27.53          | 139-ch.6.5  | Conducted spurious emission         | P       |
|      |      | 27.53, 2.1053  | 139-ch.6.5  | Radiated spurious emission          | P       |
| LTE  | 12   | 2.1046         | Gen-ch.6.12 | Conducted output power              | P       |
|      |      | 27.53          | 139-ch.2.3  | Emission bandwidth 26dB             | P       |
|      |      | 27.50          | 139-ch.6.4  | Equivalent isotropic radiated power | P       |
|      |      | 2.1049         | -           | Occupied bandwidth 99%              | P       |
|      |      | -              | 139-ch.6.4  | Peak to average ratio               | P       |
|      |      | 27.54, 2.1055  | 139-ch.6.3  | Frequency Stability                 | P       |
|      |      | 27.53, 2.1051  | 139-ch.6.5  | Conducted band-edge                 | P       |
|      |      | 27.53          | 139-ch.6.5  | Conducted spurious emission         | P       |
|      |      | 27.53, 2.1053  | 139-ch.6.5  | Radiated spurious emission          | P       |

P: Pass  
 F: Fail  
 NM: Not Measured  
 NA: Not Applicable

| Mode | Band | FCC part               | RSS part               | Test name                           | Verdict |
|------|------|------------------------|------------------------|-------------------------------------|---------|
| LTE  | 13   | 2.1046                 | Gen-ch.6.12            | Conducted output power              | P       |
|      |      | 27.53                  | 139-ch.2.3             | Emission bandwidth 26dB             | P       |
|      |      | 27.50                  | 139-ch.6.4             | Equivalent isotropic radiated power | P       |
|      |      | 2.1049                 | -                      | Occupied bandwidth 99%              | P       |
|      |      | -                      | 139-ch.6.4             | Peak to average ratio               | P       |
|      |      | 27.54, 2.1055          | 139-ch.6.3             | Frequency Stability                 | P       |
|      |      | 27.53, 2.1051          | 139-ch.6.5             | Conducted band-edge                 | P       |
|      |      | 27.53                  | 139-ch.6.5             | Conducted spurious emission         | P       |
|      |      | 27.53, 2.1053          | 139-ch.6.5             | Radiated spurious emission          | P       |
| LTE  | 17   | 2.1046                 | Gen-ch.6.12            | Conducted output power              | P       |
|      |      | 27.53                  | -                      | Emission bandwidth 26dB             | P       |
|      |      | 27.50                  | 130-ch.4.4             | Equivalent isotropic radiated power | P       |
|      |      | 2.1049                 | Gen-ch.6.6             | Occupied bandwidth 99%              | P       |
|      |      | -                      | 130-ch.4.4             | Peak to average ratio               | P       |
|      |      | 27.54, 2.1055          | 130-ch.4.3             | Frequency Stability                 | P       |
|      |      | 27.53, 2.1051          | 130-ch.4.6             | Conducted band-edge                 | P       |
|      |      | 27.53                  | 130-ch.4.6             | Conducted spurious emission         | P       |
|      |      | 27.53, 2.1053          | 130-ch.4.6             | Radiated spurious emission          | P       |
| LTE  | 26   | 2.1046                 | Gen-ch.6.12            | Conducted output power              | P       |
|      |      | 2.1049                 | Gen-ch.6.6             | Occupied bandwidth (99%)            | P       |
|      |      | 22.917                 | -                      | Occupied bandwidth (26dB)           | P       |
|      |      | 22.355, 2.1055, 90.213 | 132-ch.5.3             | Frequency Stability                 | P       |
|      |      | 22.917, 2.1051, 90.691 | 132-ch.5.5             | Band Edge conducted emission        | P       |
|      |      | 22.917, 2.1051, 90.691 | 132-ch.5.5             | Conducted Spurious emission         | P       |
|      |      | 22.913                 | 132-ch.5.4             | Effective radiated power            | P       |
|      |      | 22.917, 2.1053, 90.691 | 132-ch.5.5             | Radiated spurious emission          | P       |
|      |      | -                      | 132-ch.5.4             | Peak-to-average power ratio         | P       |
| LTE  | 41   | 2.1046                 | Gen-ch.6.12            | Conducted output power              | P       |
|      |      | 27.53                  | -                      | Emission bandwidth 26dB             | P       |
|      |      | 27.50                  | 199-ch.4.4             | Equivalent isotropic radiated power | P       |
|      |      | 2.1049                 | 199-ch.4.2, Gen-ch.6.6 | Occupied bandwidth 99%              | P       |
|      |      | -                      | -                      | Peak to average ratio               | P       |
|      |      | 27.54, 2.1055          | 199-ch.4.3             | Frequency Stability                 | P       |
|      |      | 27.53, 2.1051          | 199-ch.4.6             | Conducted band-edge                 | P       |
|      |      | 27.53                  | 199-ch.4.6             | Conducted spurious emission         | P       |
|      |      | 27.53, 2.1053          | 199-ch.4.6             | Radiated spurious emission          | P       |

P: Pass  
 F: Fail  
 NM: Not Measured  
 NA: Not Applicable



## 8. Document Revision History

| Revision # | Date       | Modified by | Details     |
|------------|------------|-------------|-------------|
| Rev. 00    | 2015-03-18 | O. Fargant  | First Issue |

# Annex A. Test & System Description

## Measurement system

Measurements were performed using the following setups. A communication tester was used to establish a communication link with the EUT and the communication tester parameters were set to get the maximum output power from the EUT.

### *Conducted Setup 1*

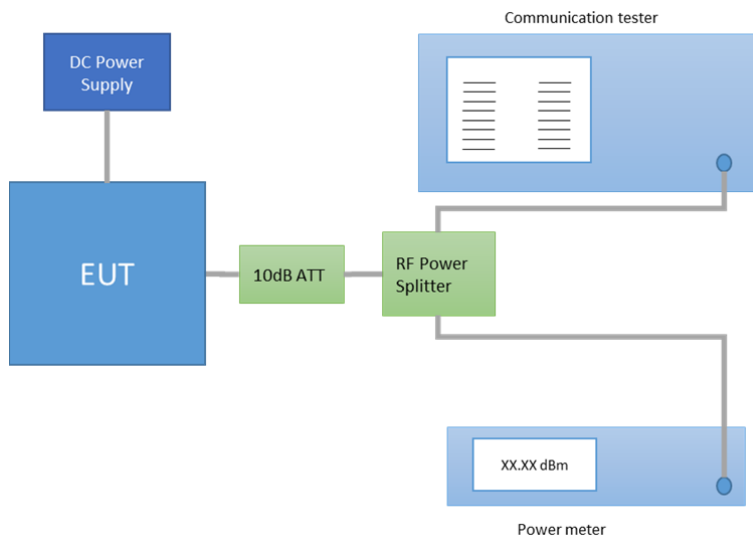

### *Conducted Setup 2*

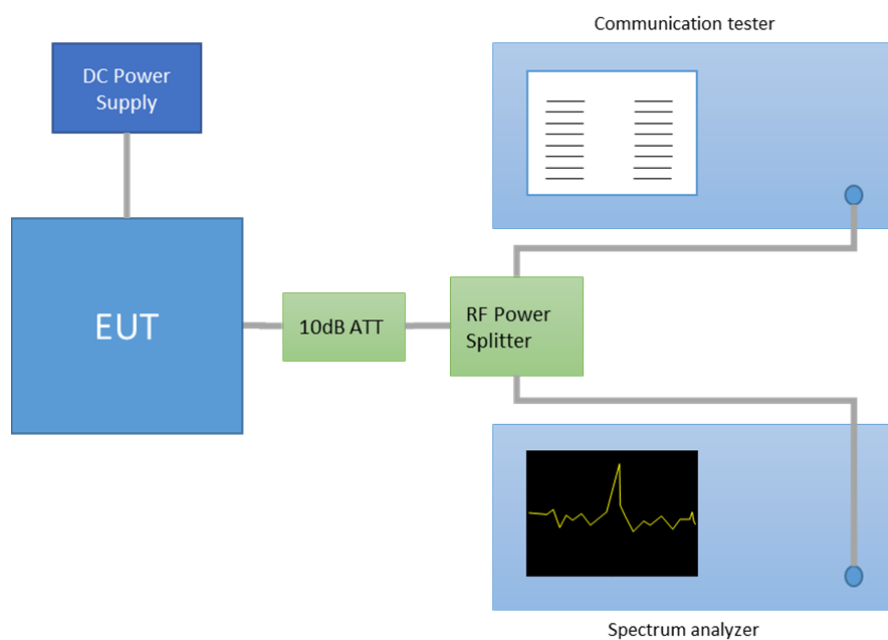

*Radiated Setup < 1GHz*

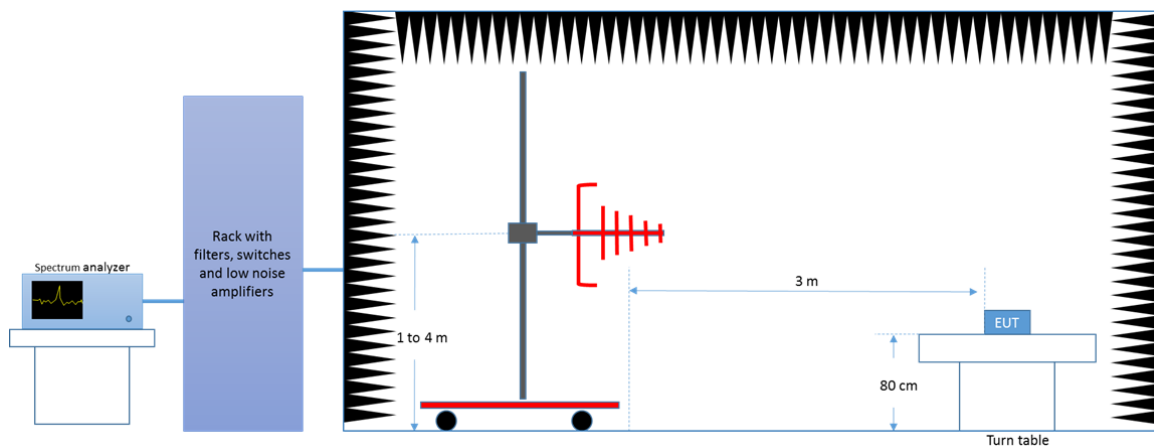

*Radiated Setup Frequency range 1 GHz to 18 GHz*

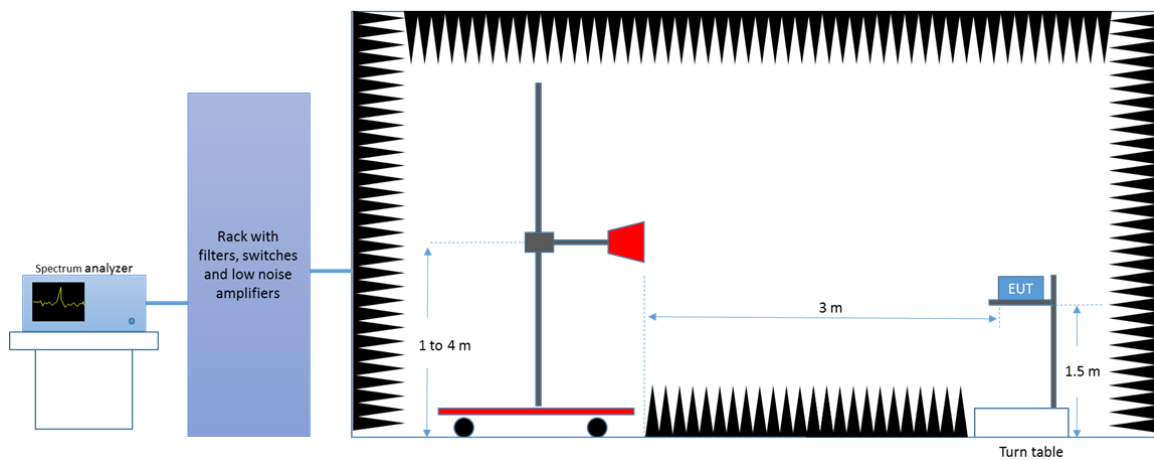

*Radiated Setup > 18GHz*

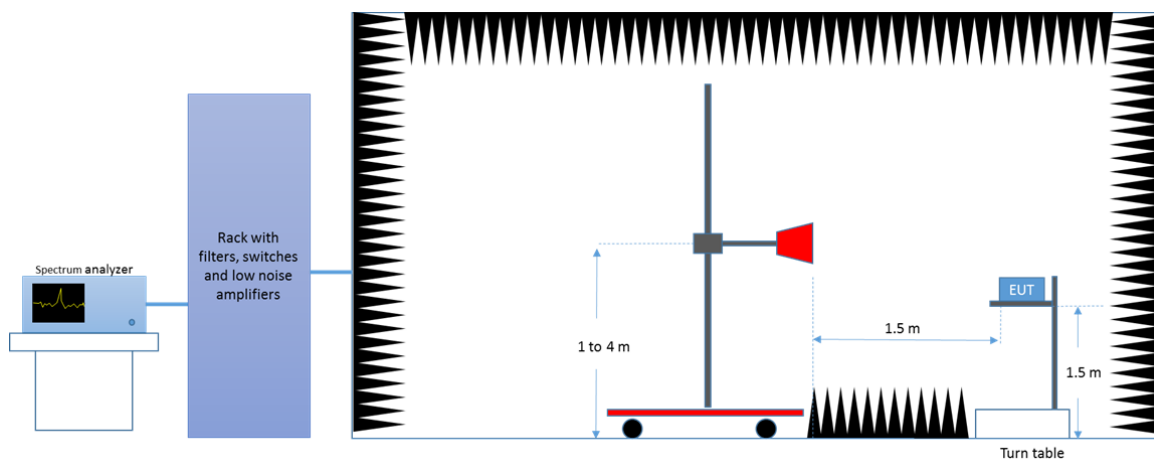

### Test Equipment List

#### Conducted Setup

| ID Number | Device               | Type/Model | Serial Number | Manufacturer    | Calibration Date | Calibration Due Date |
|-----------|----------------------|------------|---------------|-----------------|------------------|----------------------|
| 0100      | Communication tester | CMW500     | 129337        | Rohde & Schwarz | 2013-11-07       | 2015-11-07           |
| 0033      | Spectrum analyzer    | FSV40      | 101072        | Rohde & Schwarz | 2014-01-30       | 2016-01-30           |
| 0046      | Power splitter       | 11667B     | MY51360447    | Agilent         | NA               | NA                   |
| 0098      | USB Power sensor     | NRP-Z81    | 102278        | Rohde & Schwarz | 2013-07-17       | 2015-07-17           |
| NA        | 10 dB attenuator     | NA         | 4882640       | -               | NA               | NA                   |

#### Radiated Setup

| ID Number | Device   | Type/Model | Serial Number | Manufacturer    | Calibration Date | Calibration Due Date |
|-----------|--|------------|---------------|-----------------|------------------|----------------------|
| 0210      | Communication tester                           | CMW500     | 147712        | Rohde & Schwarz | NA               | NA                   |
| 0133      | Spectrum analyzer                              | FSV40      | 101358        | Rohde & Schwarz | 2014-05-03       | 2016-05-03           |
| 0137      | Log antenna<br>30 MHz – 1 GHz                  | 3142E      | 00156946      | ETS Lindgren    | 2014-05-03       | 2016-05-03           |
| 0138      | Horn antenna<br>1 GHz – 18 GHz                 | 3117       | 00152266      | ETS Lindgren    | 2014-03-04       | 2016-03-04           |
| 0141      | Horn Antenna + Pre-Amplifier<br>1 GHz – 18 GHz | 3117P      | 00157736      | ETS Lindgren    | 2014-06-03       | 2016-06-03           |
| 0139      | Horn Antenna<br>18 GHz – 26 GHz                | 114514     | 00167100      | ETS Lindgren    | 2014-04-25       | 2016-04-25           |
| 0135      | Anechoic chamber                               | FACT 3     | RFD_FA_100    | ETS Lindgren    | NA               | NA                   |

### Measurement Uncertainty Evaluation

The system uncertainty evaluation is shown in the below table:

| Measurement type              | Uncertainty [ $\pm$ dB] |
|-------------------------------|-------------------------|
| Conducted Power (power meter) | $\pm 1.0$               |
| Conducted spurious emission   | $\pm 2.9$               |
| Radiated test < 1GHz          | $\pm 3.8$               |
| Radiated test 1GHz - 27 GHz   | $\pm 4.7$               |

# Annex A. Test Results

## Test Conditions

For cellular transmission modes LTE, the device was put into operation by using an R&S CMW 500 as base station simulator.

The output power of the device was set to transmit at maximum power for all tests.

## Test results

### A.1.1 Conducted RF output power

#### Test limits

| BAND          | FCC part       | RSS part                   | Power Limits [Watts] | Max Antenna Gain [dBi] | Power Limit at antenna terminal [dBm] |
|---------------|----------------|----------------------------|----------------------|------------------------|---------------------------------------|
| LTE 12, 13, 7 | 2.1046, 27.50  | 139-ch.6.4<br>Gen-ch.6.12  | < 3 watts<br>ERP     | 2.0                    | < 32.8                                |
| LTE 26        | 2.1046, 22.913 | 132-ch.5.4,<br>Gen-ch.6.12 | < 7 watts<br>ERP     | 2.0                    | < 36.5                                |
| LTE41         | 2.1046, 27.50  | 199-ch.4.4,<br>Gen-ch.6.12 | < 3 watts<br>ERP     | 2.0                    | < 32.8                                |

#### Test procedure

The setup below was used to measure the conducted output power. The antenna terminal of the EUT is connected to the power meter and the communication tester through an attenuator and a power splitter. The power meter reading is compensated to include the RF. This test was performed according to the KDB 971168 D01 § 5.2.

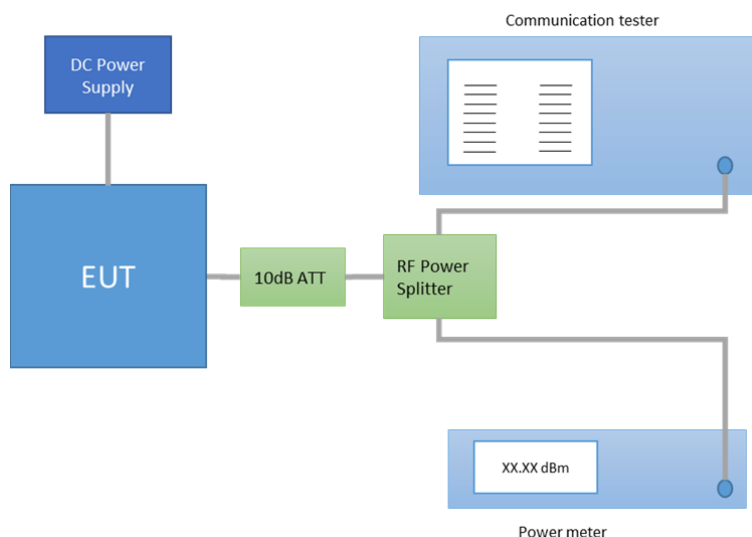

**Results tables**

| Band   | BW [MHz] | Channel Number | Frequency [MHz] | Modulation | #RB | RB position | Avg [dBm] | Peak [dBm] |
|--------|----------|----------------|-----------------|------------|-----|-------------|-----------|------------|
| LTE 12 | 1.4      | 23017          | 699.7           | QPSK       | 1   | 0           | 23.0      | 28.6       |
|        |          |                |                 |            |     | 2           | 22.6      | 28.7       |
|        |          |                |                 |            |     | 5           | 23.0      | 28.6       |
|        |          |                |                 |            | 3   | 0           | 22.9      | 28.7       |
|        |          |                |                 |            |     | 1           | 22.8      | 28.7       |
|        |          |                |                 |            |     | 2           | 22.8      | 28.7       |
|        |          |                |                 | 16QAM      | 6   | 0           | 21.9      | 28.5       |
|        |          |                |                 |            |     | 1           | 22.2      | 28.7       |
|        |          |                |                 |            |     | 2           | 21.7      | 28.7       |
|        |          |                |                 |            | 3   | 0           | 22.0      | 28.7       |
|        |          |                |                 |            |     | 1           | 21.9      | 28.7       |
|        |          |                |                 |            |     | 2           | 21.9      | 28.7       |
|        |          | 23095          | 707.5           | QPSK       | 1   | 0           | 23.1      | 29.3       |
|        |          |                |                 |            |     | 2           | 22.7      | 29.2       |
|        |          |                |                 |            |     | 5           | 23.1      | 29.3       |
|        |          |                |                 |            | 3   | 0           | 22.9      | 29.3       |
|        |          |                |                 |            |     | 1           | 22.8      | 29.4       |
|        |          |                |                 |            |     | 2           | 22.8      | 29.4       |
|        |          |                |                 | 16QAM      | 6   | 0           | 21.1      | 28.4       |
|        |          |                |                 |            |     | 1           | 22.2      | 29.3       |
|        |          |                |                 |            |     | 2           | 21.7      | 29.2       |
|        |          |                |                 |            | 3   | 0           | 21.9      | 29.4       |
|        |          |                |                 |            |     | 1           | 21.8      | 29.4       |
|        |          |                |                 |            |     | 2           | 21.8      | 29.4       |
|        |          | 23173          | 715.3           | QPSK       | 1   | 0           | 22.9      | 28.0       |
|        |          |                |                 |            |     | 2           | 22.5      | 28.1       |
|        |          |                |                 |            |     | 5           | 22.9      | 28.1       |
|        |          |                |                 |            | 3   | 0           | 22.8      | 28.1       |
|        |          |                |                 |            |     | 1           | 22.7      | 28.1       |
|        |          |                |                 |            |     | 2           | 22.7      | 28.1       |
|        |          |                |                 | 16QAM      | 6   | 0           | 21.8      | 28.0       |
|        |          |                |                 |            |     | 1           | 22.1      | 28.1       |
|        |          |                |                 |            |     | 2           | 21.7      | 28.1       |
|        |          |                |                 |            | 3   | 0           | 22.1      | 28.2       |
|        |          |                |                 |            |     | 1           | 21.9      | 28.1       |
|        |          |                |                 |            |     | 2           | 21.8      | 28.1       |
| 6      | 0        | 21.1           | 29.3            |            |     |             |           |            |
|        |          | 22.2           | 29.3            |            |     |             |           |            |
|        |          | 23.1           | 29.3            |            |     |             |           |            |
|        |          | 22.9           | 29.3            |            |     |             |           |            |
|        |          | 22.8           | 29.4            |            |     |             |           |            |
|        |          | 21.9           | 29.2            |            |     |             |           |            |
| 21.8   | 28.0     | 22.1           | 28.1            |            |     |             |           |            |
|        |          | 21.7           | 28.1            |            |     |             |           |            |
|        |          | 22.1           | 28.2            |            |     |             |           |            |
|        |          | 21.9           | 28.1            |            |     |             |           |            |
|        |          | 21.8           | 28.1            |            |     |             |           |            |
|        |          | 21.8           | 28.1            |            |     |             |           |            |
| 21.0   | 28.0     | 22.2           | 29.3            |            |     |             |           |            |
|        |          | 21.7           | 29.2            |            |     |             |           |            |
|        |          | 22.1           | 29.3            |            |     |             |           |            |
|        |          | 21.9           | 29.4            |            |     |             |           |            |
|        |          | 21.8           | 29.4            |            |     |             |           |            |
|        |          | 21.1           | 29.3            |            |     |             |           |            |

**Min Values**
**Max Values**

| Band   | BW [MHz] | Channel Number | Frequency [MHz] | Modulation | #RB  | RB position | Avg [dBm] | Peak [dBm] |
|--------|----------|----------------|-----------------|------------|------|-------------|-----------|------------|
| LTE 12 | 3        | 23025          | 700.5           | QPSK       | 1    | 0           | 23.1      | 28.6       |
|        |          |                |                 |            |      | 7           | 23.1      | 28.5       |
|        |          |                |                 |            |      | 14          | 23.0      | 28.5       |
|        |          |                |                 |            | 8    | 0           | 22.0      | 28.3       |
|        |          |                |                 |            |      | 4           | 22.0      | 28.2       |
|        |          |                |                 |            |      | 7           | 22.0      | 28.2       |
|        |          |                |                 | 15         | 0    | 22.0        | 28.2      |            |
|        |          |                |                 | 16QAM      | 1    | 0           | 22.1      | 28.6       |
|        |          |                |                 |            |      | 7           | 22.1      | 28.6       |
|        |          |                |                 |            |      | 14          | 22.0      | 28.5       |
|        |          |                |                 |            | 8    | 0           | 21.1      | 28.4       |
|        |          |                |                 |            |      | 4           | 21.1      | 28.3       |
|        |          | 7              | 21.1            |            |      | 28.3        |           |            |
|        |          | 15             | 0               | 21.1       | 28.4 |             |           |            |
|        |          | 23095          | 707.5           | QPSK       | 1    | 0           | 23.0      | 29.1       |
|        |          |                |                 |            |      | 7           | 23.1      | 29.2       |
|        |          |                |                 |            |      | 14          | 22.9      | 29.1       |
|        |          |                |                 |            | 8    | 0           | 22.0      | 29.0       |
|        |          |                |                 |            |      | 4           | 22.0      | 29.1       |
|        |          |                |                 |            |      | 7           | 22.0      | 29.1       |
|        |          |                |                 | 15         | 0    | 22.0        | 29.0      |            |
|        |          |                |                 | 16QAM      | 1    | 0           | 22.2      | 28.9       |
|        |          |                |                 |            |      | 7           | 22.2      | 28.9       |
|        |          |                |                 |            |      | 14          | 22.1      | 28.9       |
|        |          |                |                 |            | 8    | 0           | 21.1      | 29.1       |
|        |          |                |                 |            |      | 4           | 21.1      | 29.1       |
|        |          | 7              | 21.2            |            |      | 29.0        |           |            |
|        |          | 15             | 0               | 21.1       | 28.9 |             |           |            |
|        |          | 23165          | 714.5           | QPSK       | 1    | 0           | 22.9      | 28.3       |
|        |          |                |                 |            |      | 7           | 23.0      | 28.0       |
|        |          |                |                 |            |      | 14          | 22.8      | 28.1       |
|        |          |                |                 |            | 8    | 0           | 21.9      | 27.8       |
|        |          |                |                 |            |      | 4           | 21.8      | 27.8       |
|        |          |                |                 |            |      | 7           | 21.8      | 27.7       |
|        |          |                |                 | 15         | 0    | 21.8        | 27.9      |            |
|        |          |                |                 | 16QAM      | 1    | 0           | 22.1      | 28.4       |
| 7      | 22.2     |                |                 |            |      | 28.1        |           |            |
| 14     | 22.1     |                |                 |            |      | 28.2        |           |            |
| 8      | 0        |                |                 |            | 21.1 | 27.9        |           |            |
|        | 4        |                |                 |            | 21.0 | 27.9        |           |            |
|        | 7        | 21.1           | 27.9            |            |      |             |           |            |
| 15     | 0        | 21.0           | 27.9            |            |      |             |           |            |

**Min Values**
**Max Values**

| Band   | BW [MHz] | Channel Number | Frequency [MHz] | Modulation | #RB  | RB position | Avg [dBm] | Peak [dBm] |
|--------|----------|----------------|-----------------|------------|------|-------------|-----------|------------|
| LTE 12 | 5        | 23035          | 701.5           | QPSK       | 1    | 0           | 22.7      | 28.5       |
|        |          |                |                 |            |      | 12          | 22.8      | 28.3       |
|        |          |                |                 |            |      | 24          | 22.7      | 28.3       |
|        |          |                |                 |            | 12   | 0           | 21.9      | 28.3       |
|        |          |                |                 |            |      | 6           | 21.8      | 28.2       |
|        |          |                |                 |            |      | 11          | 21.9      | 28.1       |
|        |          |                |                 | 25         | 0    | 21.8        | 27.9      |            |
|        |          |                |                 | 16QAM      | 1    | 0           | 21.9      | 28.3       |
|        |          |                |                 |            |      | 12          | 21.9      | 28.2       |
|        |          |                |                 |            |      | 24          | 21.9      | 28.2       |
|        |          |                |                 |            | 12   | 0           | 21.0      | 28.3       |
|        |          |                |                 |            |      | 6           | 20.9      | 28.2       |
|        |          | 11             | 21.0            |            |      | 28.2        |           |            |
|        |          | 25             | 0               | 20.9       | 28.0 |             |           |            |
|        |          | 23095          | 707.5           | QPSK       | 1    | 0           | 22.7      | 28.7       |
|        |          |                |                 |            |      | 12          | 22.8      | 29.3       |
|        |          |                |                 |            |      | 24          | 22.7      | 29.0       |
|        |          |                |                 |            | 12   | 0           | 21.9      | 28.8       |
|        |          |                |                 |            |      | 6           | 21.8      | 29.0       |
|        |          |                |                 |            |      | 11          | 21.9      | 28.9       |
|        |          |                |                 | 25         | 0    | 21.8        | 28.5      |            |
|        |          |                |                 | 16QAM      | 1    | 0           | 21.8      | 28.6       |
|        |          |                |                 |            |      | 12          | 21.9      | 29.2       |
|        |          |                |                 |            |      | 24          | 21.8      | 29.0       |
|        |          |                |                 |            | 12   | 0           | 21.0      | 28.8       |
|        |          |                |                 |            |      | 6           | 21.0      | 28.9       |
|        |          | 11             | 21.0            |            |      | 28.9        |           |            |
|        |          | 25             | 0               | 20.9       | 28.3 |             |           |            |
|        |          | 23155          | 713.5           | QPSK       | 1    | 0           | 22.7      | 28.8       |
|        |          |                |                 |            |      | 12          | 22.7      | 28.3       |
|        |          |                |                 |            |      | 24          | 22.6      | 28.1       |
|        |          |                |                 |            | 12   | 0           | 21.8      | 28.2       |
|        |          |                |                 |            |      | 6           | 21.7      | 28.0       |
|        |          |                |                 |            |      | 11          | 21.7      | 27.8       |
|        |          |                |                 | 25         | 0    | 21.7        | 28.1      |            |
|        |          |                |                 | 16QAM      | 1    | 0           | 21.8      | 28.6       |
| 12     | 21.7     |                |                 |            |      | 28.1        |           |            |
| 24     | 21.7     |                |                 |            |      | 28.0        |           |            |
| 12     | 0        |                |                 |            | 20.9 | 28.2        |           |            |
|        | 6        |                |                 |            | 20.8 | 27.9        |           |            |
|        | 11       | 20.8           | 27.8            |            |      |             |           |            |
| 25     | 0        | 20.9           | 28.0            |            |      |             |           |            |

**Min Values**
**Max Values**



| Band   | BW [MHz] | Channel Number | Frequency [MHz] | Modulation | #RB  | RB position | Avg [dBm] | Peak [dBm] |
|--------|----------|----------------|-----------------|------------|------|-------------|-----------|------------|
| LTE 12 | 10       | 23060          | 704.0           | QPSK       | 1    | 0           | 22.9      | 28.6       |
|        |          |                |                 |            |      | 24          | 22.9      | 28.6       |
|        |          |                |                 |            |      | 49          | 22.9      | 29.2       |
|        |          |                |                 |            | 25   | 0           | 21.9      | 28.0       |
|        |          |                |                 |            |      | 12          | 21.8      | 28.1       |
|        |          |                |                 |            |      | 24          | 21.9      | 28.9       |
|        |          |                |                 | 50         | 0    | 21.9        | 28.6      |            |
|        |          |                |                 | 16QAM      | 1    | 0           | 22.1      | 28.7       |
|        |          |                |                 |            |      | 24          | 22.1      | 28.6       |
|        |          |                |                 |            |      | 49          | 22.1      | 29.2       |
|        |          |                |                 |            | 25   | 0           | 21.0      | 28.0       |
|        |          |                |                 |            |      | 12          | 21.0      | 28.0       |
|        |          | 24             | 21.0            |            |      | 28.4        |           |            |
|        |          | 50             | 0               | 21.0       | 28.6 |             |           |            |
|        |          | 23095          | 707.5           | QPSK       | 1    | 0           | 22.9      | 28.4       |
|        |          |                |                 |            |      | 24          | 22.9      | 29.3       |
|        |          |                |                 |            |      | 49          | 22.7      | 28.5       |
|        |          |                |                 |            | 25   | 0           | 21.9      | 28.0       |
|        |          |                |                 |            |      | 12          | 21.8      | 28.0       |
|        |          |                |                 |            |      | 24          | 21.8      | 28.1       |
|        |          |                |                 | 50         | 0    | 21.8        | 28.3      |            |
|        |          |                |                 | 16QAM      | 1    | 0           | 22.0      | 28.4       |
|        |          |                |                 |            |      | 24          | 21.9      | 29.3       |
|        |          |                |                 |            |      | 49          | 21.8      | 28.6       |
|        |          |                |                 |            | 25   | 0           | 21.0      | 28.0       |
|        |          |                |                 |            |      | 12          | 20.9      | 28.1       |
|        |          | 24             | 20.9            |            |      | 28.1        |           |            |
|        |          | 50             | 0               | 21.0       | 28.5 |             |           |            |
|        |          | 23130          | 711.0           | QPSK       | 1    | 0           | 22.9      | 29.0       |
|        |          |                |                 |            |      | 24          | 22.8      | 28.6       |
| 49     | 22.7     |                |                 |            |      | 27.9        |           |            |
| 25     | 0        |                |                 |            | 21.9 | 28.6        |           |            |
|        | 12       |                |                 |            | 21.8 | 28.2        |           |            |
|        | 24       |                |                 |            | 21.7 | 27.8        |           |            |
| 50     | 0        |                |                 | 21.8       | 28.4 |             |           |            |
| 16QAM  | 1        |                |                 | 0          | 22.1 | 28.9        |           |            |
|        |          |                |                 | 24         | 21.9 | 28.4        |           |            |
|        |          |                |                 | 49         | 21.8 | 27.9        |           |            |
|        | 25       |                |                 | 0          | 21.0 | 28.7        |           |            |
|        |          |                |                 | 12         | 20.8 | 28.2        |           |            |
|        |          | 24             | 20.8            | 27.8       |      |             |           |            |
| 50     | 0        | 20.9           | 28.2            |            |      |             |           |            |

**Min Values**
**Max Values**

| Band   | BW [MHz] | Channel Number | Frequency [MHz] | Modulation | #RB  | RB position | Avg [dBm]   | Peak [dBm] |
|--------|----------|----------------|-----------------|------------|------|-------------|-------------|------------|
| LTE 13 | 5        | 23205          | 779.5           | QPSK       | 1    | 0           | <b>23.2</b> | 27.8       |
|        |          |                |                 |            |      | 12          | 23.1        | 28.1       |
|        |          |                |                 |            |      | 24          | 23.0        | 28.4       |
|        |          |                |                 |            | 12   | 0           | 22.3        | 27.1       |
|        |          |                |                 |            |      | 6           | 22.2        | 27.0       |
|        |          |                |                 |            |      | 11          | 22.3        | 27.2       |
|        |          |                |                 | 25         | 0    | 22.3        | 27.5        |            |
|        |          |                |                 | 16QAM      | 1    | 0           | <b>22.3</b> | 27.5       |
|        |          |                |                 |            |      | 12          | 22.4        | 28.1       |
|        |          |                |                 |            |      | 24          | 22.2        | 28.3       |
|        |          |                |                 |            | 12   | 0           | 21.3        | 27.1       |
|        |          |                |                 |            |      | 6           | 21.2        | 27.0       |
|        |          | 11             | 21.2            |            |      | 27.1        |             |            |
|        |          | 25             | 0               | 21.2       | 27.4 |             |             |            |
|        |          | 23230          | 782.0           | QPSK       | 1    | 0           | 23.1        | 27.5       |
|        |          |                |                 |            |      | 12          | 23.1        | 28.2       |
|        |          |                |                 |            |      | 24          | 22.9        | 28.3       |
|        |          |                |                 |            | 12   | 0           | 22.2        | 27.6       |
|        |          |                |                 |            |      | 6           | <b>22.1</b> | 27.8       |
|        |          |                |                 |            |      | 11          | 22.1        | 28.1       |
|        |          |                |                 | 25         | 0    | 22.2        | 27.8        |            |
|        |          |                |                 | 16QAM      | 1    | 0           | 22.2        | 27.5       |
|        |          |                |                 |            |      | 12          | 22.2        | 28.4       |
|        |          |                |                 |            |      | 24          | 22.1        | 28.3       |
|        |          |                |                 |            | 12   | 0           | 21.1        | 27.4       |
|        |          |                |                 |            |      | 6           | 21.1        | 27.8       |
|        |          | 11             | 21.1            |            |      | 28.1        |             |            |
|        |          | 25             | 0               | 21.1       | 27.7 |             |             |            |
|        |          | 23255          | 784.5           | QPSK       | 1    | 0           | 23.0        | 28.2       |
|        |          |                |                 |            |      | 12          | 23.0        | 28.4       |
|        |          |                |                 |            |      | 24          | 22.9        | 27.6       |
|        |          |                |                 |            | 12   | 0           | 22.2        | 28.1       |
|        |          |                |                 |            |      | 6           | 22.1        | 27.9       |
|        |          |                |                 |            |      | 11          | 22.1        | 27.6       |
|        |          |                |                 | 25         | 0    | 22.1        | 27.6        |            |
|        |          |                |                 | 16QAM      | 1    | 0           | 22.1        | 28.2       |
| 12     | 22.1     |                |                 |            |      | 28.4        |             |            |
| 24     | 21.9     |                |                 |            |      | 27.5        |             |            |
| 12     | 0        |                |                 |            | 21.1 | 28.0        |             |            |
|        | 6        |                |                 |            | 21.0 | 27.9        |             |            |
|        | 11       | <b>21.0</b>    | 27.6            |            |      |             |             |            |
| 25     | 0        | 21.0           | 27.7            |            |      |             |             |            |

Min Values  
Max Values

| Band   | BW [MHz] | Channel Number | Frequency [MHz] | Modulation | #RB   | RB position | Avg [dBm]   | Peak [dBm]  |      |
|--------|----------|----------------|-----------------|------------|-------|-------------|-------------|-------------|------|
| LTE 13 | 10       | 23230          | 782.0           | QPSK       | 1     | 0           | <b>23.6</b> | 27.3        |      |
|        |          |                |                 |            |       | 24          | 23.0        | 28.4        |      |
|        |          |                |                 |            |       | 49          | 22.6        | 27.8        |      |
|        |          |                |                 |            | 25    | 0           | 22.4        | 27.9        |      |
|        |          |                |                 |            |       | 12          | 22.2        | 28.0        |      |
|        |          |                |                 |            |       | 24          | <b>22.2</b> | 27.7        |      |
|        |          |                |                 |            | 50    | 0           | 22.3        | 28.2        |      |
|        |          |                |                 |            | 16QAM | 1           | 0           | <b>22.8</b> | 27.2 |
|        |          |                |                 |            |       |             | 24          | 22.2        | 28.6 |
|        |          |                |                 | 49         |       |             | 21.8        | 27.8        |      |
|        |          |                |                 | 25         |       | 0           | 21.3        | 27.8        |      |
|        |          |                |                 |            |       | 12          | 21.2        | 28.0        |      |
|        |          |                |                 |            |       | 24          | <b>21.2</b> | 27.7        |      |
|        |          |                |                 | 50         | 0     | 21.2        | 28.3        |             |      |

**Min Values**

**Max Values**

| Band   | BW [MHz] | Channel Number | Frequency [MHz] | Modulation | #RB   | RB position | Avg [dBm]   | Peak [dBm] |      |      |      |
|--------|----------|----------------|-----------------|------------|-------|-------------|-------------|------------|------|------|------|
| LTE 26 | 1.4      | 26697          | 814.7           | QPSK       | 1     | 0           | <b>20.3</b> | 26.5       |      |      |      |
|        |          |                |                 |            |       | 2           | 20.8        | 26.5       |      |      |      |
|        |          |                |                 |            |       | 5           | 21.3        | 26.5       |      |      |      |
|        |          |                |                 |            | 3     | 0           | 23.0        | 28.0       |      |      |      |
|        |          |                |                 |            |       | 1           | 22.9        | 27.9       |      |      |      |
|        |          |                |                 |            |       | 2           | 22.8        | 27.8       |      |      |      |
|        |          |                |                 | 6          | 0     | 22.0        | 27.8        |            |      |      |      |
|        |          |                |                 | 16QAM      | 1     | 0           | <b>20.3</b> | 26.6       |      |      |      |
|        |          |                |                 |            |       | 2           | 20.8        | 27.3       |      |      |      |
|        |          |                |                 |            |       | 5           | 21.2        | 27.2       |      |      |      |
|        |          |                |                 |            | 3     | 0           | <b>22.0</b> | 27.9       |      |      |      |
|        |          |                |                 |            |       | 1           | 21.9        | 27.9       |      |      |      |
|        |          | 2              | 21.9            |            |       | 27.8        |             |            |      |      |      |
|        |          | 6              | 0               | 21.0       | 27.8  |             |             |            |      |      |      |
|        |          | 26865          | 831.5           | QPSK       | 1     | 0           | <b>23.0</b> | 28.2       |      |      |      |
|        |          |                |                 |            |       | 2           | 22.6        | 28.3       |      |      |      |
|        |          |                |                 |            |       | 5           | 23.0        | 28.1       |      |      |      |
|        |          |                |                 |            | 3     | 0           | 22.8        | 28.4       |      |      |      |
|        |          |                |                 |            |       | 1           | 22.7        | 28.4       |      |      |      |
|        |          |                |                 |            |       | 2           | 22.7        | 28.3       |      |      |      |
|        |          |                |                 |            | 6     | 0           | 21.8        | 27.2       |      |      |      |
|        |          |                |                 |            | 16QAM | 1           | 0           | 22.0       | 27.7 |      |      |
|        |          |                |                 |            |       |             | 2           | 21.6       | 27.9 |      |      |
|        |          |                |                 | 5          |       |             | 22.0        | 27.9       |      |      |      |
|        |          |                |                 | 3          |       | 0           | 21.9        | 28.4       |      |      |      |
|        |          |                |                 |            |       | 1           | 21.7        | 28.4       |      |      |      |
|        |          |                |                 |            |       | 2           | 21.7        | 28.3       |      |      |      |
|        |          |                |                 | 6          |       | 0           | 20.9        | 27.2       |      |      |      |
|        |          |                |                 | 27033      |       | 848.3       | QPSK        | 1          | 0    | 22.6 | 27.3 |
|        |          |                |                 |            |       |             |             |            | 2    | 22.2 | 27.4 |
|        |          |                |                 |            | 5     |             |             |            | 22.6 | 26.7 |      |
|        |          |                |                 |            | 3     |             |             | 0          | 22.5 | 27.4 |      |
|        |          | 1              | 22.3            |            |       |             |             | 27.2       |      |      |      |
|        |          | 2              | 22.3            |            |       |             |             | 27.2       |      |      |      |
|        |          | 6              | 0               |            | 21.4  |             | 27.2        |            |      |      |      |
|        |          | 16QAM          | 1               |            | 0     |             | 21.7        | 27.2       |      |      |      |
| 2      | 21.3     |                |                 |            | 27.1  |             |             |            |      |      |      |
| 5      | 21.7     |                |                 |            | 27.0  |             |             |            |      |      |      |
| 3      | 0        |                | 21.4            |            | 27.5  |             |             |            |      |      |      |
|        | 1        |                | 21.3            |            | 27.4  |             |             |            |      |      |      |
|        | 2        |                | 21.3            | 27.4       |       |             |             |            |      |      |      |
| 6      | 0        | 20.4           | 26.4            |            |       |             |             |            |      |      |      |

**Min Values**  
**Max Values**

| Band   | BW [MHz] | Channel Number | Frequency [MHz] | Modulation | #RB  | RB position | Avg [dBm]   | Peak [dBm] |
|--------|----------|----------------|-----------------|------------|------|-------------|-------------|------------|
| LTE 26 | 3        | 26705          | 815.5           | QPSK       | 1    | 0           | 20.2        | 26.3       |
|        |          |                |                 |            |      | 7           | <b>20.2</b> | 26.1       |
|        |          |                |                 |            |      | 14          | 21.1        | 27.0       |
|        |          |                |                 |            | 8    | 0           | 22.0        | 27.7       |
|        |          |                |                 |            |      | 4           | 22.0        | 27.6       |
|        |          |                |                 |            |      | 7           | 22.1        | 27.4       |
|        |          |                |                 | 15         | 0    | 22.0        | 27.6        |            |
|        |          |                |                 | 16QAM      | 1    | 0           | <b>20.2</b> | 26.7       |
|        |          |                |                 |            |      | 7           | 20.4        | 26.5       |
|        |          |                |                 |            |      | 14          | 21.2        | 27.6       |
|        |          |                |                 |            | 8    | 0           | 21.1        | 27.7       |
|        |          |                |                 |            |      | 4           | 21.1        | 27.5       |
|        |          | 7              | 21.1            |            |      | 27.4        |             |            |
|        |          | 15             | 0               | 21.0       | 27.6 |             |             |            |
|        |          | 26865          | 831.5           | QPSK       | 1    | 0           | 22.9        | 28.6       |
|        |          |                |                 |            |      | 7           | <b>23.0</b> | 28.1       |
|        |          |                |                 |            |      | 14          | 22.9        | 28.1       |
|        |          |                |                 |            | 8    | 0           | 21.9        | 27.1       |
|        |          |                |                 |            |      | 4           | 21.9        | 27.0       |
|        |          |                |                 |            |      | 7           | 21.8        | 26.8       |
|        |          |                |                 | 15         | 0    | 21.8        | 26.9        |            |
|        |          |                |                 | 16QAM      | 1    | 0           | 21.9        | 28.3       |
|        |          |                |                 |            |      | 7           | <b>22.0</b> | 27.9       |
|        |          |                |                 |            |      | 14          | 21.9        | 27.8       |
|        |          |                |                 |            | 8    | 0           | 20.9        | 27.1       |
|        |          |                |                 |            |      | 4           | 20.9        | 27.0       |
|        |          | 7              | 20.9            |            |      | 27.0        |             |            |
|        |          | 15             | 0               | 20.8       | 27.0 |             |             |            |
|        |          | 27025          | 847.5           | QPSK       | 1    | 0           | 22.6        | 27.6       |
|        |          |                |                 |            |      | 7           | 22.6        | 27.6       |
|        |          |                |                 |            |      | 14          | 22.5        | 27.3       |
|        |          |                |                 |            | 8    | 0           | 21.6        | 26.6       |
|        |          |                |                 |            |      | 4           | 21.6        | 26.4       |
|        |          |                |                 |            |      | 7           | 21.5        | 26.3       |
|        |          |                |                 | 15         | 0    | 21.6        | 26.5        |            |
|        |          |                |                 | 16QAM      | 1    | 0           | 21.8        | 27.8       |
| 7      | 21.8     |                |                 |            |      | 27.7        |             |            |
| 14     | 21.6     |                |                 |            |      | 27.2        |             |            |
| 8      | 0        |                |                 |            | 20.6 | 26.8        |             |            |
|        | 4        |                |                 |            | 20.6 | 26.6        |             |            |
|        | 7        | 20.6           | 26.5            |            |      |             |             |            |
| 15     | 0        | 20.6           | 26.5            |            |      |             |             |            |

| Band   | BW [MHz] | Channel Number | Frequency [MHz] | Modulation | #RB  | RB position | Avg [dBm]   | Peak [dBm] |
|--------|----------|----------------|-----------------|------------|------|-------------|-------------|------------|
| LTE 26 | 5        | 26715          | 816.5           | QPSK       | 1    | 0           | 20.9        | 26.6       |
|        |          |                |                 |            |      | 12          | <b>20.8</b> | 26.2       |
|        |          |                |                 |            |      | 24          | 20.8        | 26.4       |
|        |          |                |                 |            | 12   | 0           | 21.9        | 27.6       |
|        |          |                |                 |            |      | 6           | 21.9        | 27.4       |
|        |          |                |                 |            |      | 11          | 21.8        | 27.3       |
|        |          |                |                 | 25         | 0    | 21.9        | 27.6        |            |
|        |          |                |                 | 16QAM      | 1    | 0           | 21.0        | 27.1       |
|        |          |                |                 |            |      | 12          | 21.0        | 26.9       |
|        |          |                |                 |            |      | 24          | 20.9        | 26.8       |
|        |          |                |                 |            | 12   | 0           | 20.9        | 27.5       |
|        |          |                |                 |            |      | 6           | 20.9        | 27.3       |
|        |          | 11             | 20.9            |            |      | 27.3        |             |            |
|        |          | 25             | 0               | 20.9       | 27.5 |             |             |            |
|        |          | 26865          | 831.5           | QPSK       | 1    | 0           | 22.6        | 27.5       |
|        |          |                |                 |            |      | 12          | <b>22.6</b> | 27.8       |
|        |          |                |                 |            |      | 24          | 22.5        | 27.3       |
|        |          |                |                 |            | 12   | 0           | 21.8        | 27.0       |
|        |          |                |                 |            |      | 6           | 21.7        | 26.8       |
|        |          |                |                 |            |      | 11          | 21.7        | 26.6       |
|        |          |                |                 | 25         | 0    | 21.7        | 26.7        |            |
|        |          |                |                 | 16QAM      | 1    | 0           | 21.7        | 27.5       |
|        |          |                |                 |            |      | 12          | <b>21.8</b> | 27.1       |
|        |          |                |                 |            |      | 24          | 21.6        | 27.7       |
|        |          |                |                 |            | 12   | 0           | 20.7        | 27.1       |
|        |          |                |                 |            |      | 6           | 20.7        | 26.9       |
|        |          | 11             | 20.7            |            |      | 26.7        |             |            |
|        |          | 25             | 0               | 20.7       | 26.6 |             |             |            |
|        |          | 27015          | 846.5           | QPSK       | 1    | 0           | 22.4        | 27.9       |
|        |          |                |                 |            |      | 12          | 22.4        | 27.2       |
|        |          |                |                 |            |      | 24          | 22.2        | 26.5       |
|        |          |                |                 |            | 12   | 0           | 21.5        | 27.2       |
|        |          |                |                 |            |      | 6           | 21.4        | 26.9       |
|        |          |                |                 |            |      | 11          | 21.4        | 26.6       |
|        |          |                |                 | 25         | 0    | 21.4        | 26.9        |            |
|        |          |                |                 | 16QAM      | 1    | 0           | 21.5        | 27.9       |
| 12     | 21.4     |                |                 |            |      | 27.4        |             |            |
| 24     | 21.4     |                |                 |            |      | 27.4        |             |            |
| 12     | 0        |                |                 |            | 20.4 | 27.3        |             |            |
|        | 6        |                |                 |            | 20.4 | 27.0        |             |            |
|        | 11       | <b>20.4</b>    | 26.7            |            |      |             |             |            |
| 25     | 0        | 20.4           | 27.0            |            |      |             |             |            |

| Band   | BW [MHz] | Channel Number | Frequency [MHz] | Modulation | #RB   | RB position | Avg [dBm]   | Peak [dBm]  |      |      |      |
|--------|----------|----------------|-----------------|------------|-------|-------------|-------------|-------------|------|------|------|
| LTE 26 | 10       | 26740          | 819.0           | QPSK       | 1     | 0           | 21.1        | 26.8        |      |      |      |
|        |          |                |                 |            |       | 24          | 21.0        | 26.5        |      |      |      |
|        |          |                |                 |            |       | 49          | <b>20.8</b> | 27.4        |      |      |      |
|        |          |                |                 |            | 25    | 0           | 21.9        | 27.6        |      |      |      |
|        |          |                |                 |            |       | 12          | 21.9        | 27.8        |      |      |      |
|        |          |                |                 |            |       | 24          | 21.9        | 28.3        |      |      |      |
|        |          |                |                 | 50         | 0     | 22.0        | 28.4        |             |      |      |      |
|        |          |                |                 | 16QAM      | 1     | 0           | 21.3        | 28.0        |      |      |      |
|        |          |                |                 |            |       | 24          | 21.2        | 27.7        |      |      |      |
|        |          |                |                 |            |       | 49          | 21.1        | 27.9        |      |      |      |
|        |          |                |                 |            | 25    | 0           | 21.0        | 27.6        |      |      |      |
|        |          |                |                 |            |       | 12          | 20.9        | 27.7        |      |      |      |
|        |          | 24             | 20.9            |            |       | 28.2        |             |             |      |      |      |
|        |          | 50             | 0               | 20.9       | 28.2  |             |             |             |      |      |      |
|        |          | 26865          | 831.5           | QPSK       | 1     | 0           | <b>22.9</b> | 28.5        |      |      |      |
|        |          |                |                 |            |       | 24          | 22.8        | 28.0        |      |      |      |
|        |          |                |                 |            |       | 49          | 22.6        | 27.4        |      |      |      |
|        |          |                |                 |            | 25    | 0           | 21.9        | 27.1        |      |      |      |
|        |          |                |                 |            |       | 12          | 21.7        | 26.7        |      |      |      |
|        |          |                |                 |            |       | 24          | 21.7        | 27.6        |      |      |      |
|        |          |                |                 |            | 50    | 0           | 21.8        | 27.1        |      |      |      |
|        |          |                |                 |            | 16QAM | 1           | 0           | <b>22.0</b> | 28.1 |      |      |
|        |          |                |                 |            |       |             | 24          | 21.8        | 27.9 |      |      |
|        |          |                |                 | 49         |       |             | 21.7        | 27.5        |      |      |      |
|        |          |                |                 | 25         |       | 0           | 20.8        | 27.2        |      |      |      |
|        |          |                |                 |            |       | 12          | 20.7        | 26.8        |      |      |      |
|        |          |                |                 |            |       | 24          | 20.7        | 26.3        |      |      |      |
|        |          |                |                 | 50         |       | 0           | 20.7        | 27.1        |      |      |      |
|        |          |                |                 | 26990      |       | 844.0       | QPSK        | 1           | 0    | 22.7 | 27.7 |
|        |          |                |                 |            |       |             |             |             | 24   | 22.5 | 28.1 |
|        |          |                |                 |            | 49    |             |             |             | 22.4 | 26.7 |      |
|        |          |                |                 |            | 25    |             |             | 0           | 21.7 | 27.7 |      |
|        |          | 12             | 21.6            |            |       |             |             | 27.6        |      |      |      |
|        |          | 24             | 21.5            |            |       |             |             | 27.1        |      |      |      |
|        |          | 50             | 0               |            | 21.6  |             | 27.7        |             |      |      |      |
|        |          | 16QAM          | 1               |            | 0     |             | 21.8        | 27.9        |      |      |      |
| 24     | 21.7     |                |                 |            | 28.1  |             |             |             |      |      |      |
| 49     | 21.6     |                |                 |            | 26.8  |             |             |             |      |      |      |
| 25     | 0        |                | 20.6            |            | 27.8  |             |             |             |      |      |      |
|        | 12       |                | 20.5            |            | 27.6  |             |             |             |      |      |      |
|        | 24       |                | <b>20.4</b>     | 27.2       |       |             |             |             |      |      |      |
| 50     | 0        | 20.5           | 27.7            |            |       |             |             |             |      |      |      |

| Band   | BW [MHz] | Channel Number | Frequency [MHz] | Modulation | #RB  | RB position | Avg [dBm]   | Peak [dBm] |
|--------|----------|----------------|-----------------|------------|------|-------------|-------------|------------|
| LTE 26 | 15       | 26765          | 821.5           | QPSK       | 1    | 0           | 20.9        | 26.3       |
|        |          |                |                 |            |      | 37          | 20.9        | 26.9       |
|        |          |                |                 |            |      | 74          | <b>20.7</b> | 26.7       |
|        |          |                |                 |            | 36   | 0           | 21.9        | 26.7       |
|        |          |                |                 |            |      | 16          | 21.8        | 27.1       |
|        |          |                |                 |            |      | 35          | 21.8        | 27.7       |
|        |          |                |                 | 75         | 0    | 21.8        | 27.4        |            |
|        |          |                |                 | 16QAM      | 1    | 0           | 21.0        | 26.5       |
|        |          |                |                 |            |      | 37          | 20.9        | 27.3       |
|        |          |                |                 |            |      | 74          | 20.7        | 27.4       |
|        |          |                |                 |            | 36   | 0           | 20.9        | 26.5       |
|        |          |                |                 |            |      | 16          | 20.8        | 27.1       |
|        |          | 35             | 20.8            |            |      | 27.6        |             |            |
|        |          | 75             | 0               | 20.8       | 27.4 |             |             |            |
|        |          | 26865          | 831.5           | QPSK       | 1    | 0           | 22.5        | 28.0       |
|        |          |                |                 |            |      | 37          | <b>22.6</b> | 27.2       |
|        |          |                |                 |            |      | 74          | 22.2        | 26.8       |
|        |          |                |                 |            | 36   | 0           | 21.8        | 27.3       |
|        |          |                |                 |            |      | 16          | 21.6        | 26.6       |
|        |          |                |                 |            |      | 35          | 21.7        | 27.6       |
|        |          |                |                 | 75         | 0    | 21.7        | 27.3        |            |
|        |          |                |                 | 16QAM      | 1    | 0           | <b>21.8</b> | 28.2       |
|        |          |                |                 |            |      | 37          | 21.7        | 27.8       |
|        |          |                |                 |            |      | 74          | 21.5        | 27.4       |
|        |          |                |                 |            | 36   | 0           | 20.9        | 27.2       |
|        |          |                |                 |            |      | 16          | 20.7        | 26.6       |
|        |          | 35             | 20.7            |            |      | 26.3        |             |            |
|        |          | 75             | 0               | 20.8       | 27.2 |             |             |            |
|        |          | 26965          | 841.5           | QPSK       | 1    | 0           | 22.5        | 26.7       |
|        |          |                |                 |            |      | 37          | 22.4        | 27.8       |
| 74     | 22.2     |                |                 |            |      | 26.1        |             |            |
| 36     | 0        |                |                 |            | 21.7 | 26.7        |             |            |
|        | 16       |                |                 |            | 21.5 | 27.3        |             |            |
|        | 35       |                |                 |            | 21.5 | 27.1        |             |            |
| 75     | 0        |                |                 | 21.6       | 27.4 |             |             |            |
| 16QAM  | 1        |                |                 | 0          | 21.6 | 27.0        |             |            |
|        |          |                |                 | 37         | 21.4 | 27.8        |             |            |
|        |          |                |                 | 74         | 21.2 | 26.7        |             |            |
|        | 36       |                |                 | 0          | 20.8 | 26.9        |             |            |
|        |          |                |                 | 16         | 20.6 | 27.4        |             |            |
|        |          | 35             | <b>20.6</b>     | 27.3       |      |             |             |            |
| 75     | 0        | 20.6           | 27.5            |            |      |             |             |            |



| Band  | BW [MHz] | Channel Number | Frequency [MHz] | Modulation | #RB | RB position | Avg [dBm]   | Peak [dBm] |
|-------|----------|----------------|-----------------|------------|-----|-------------|-------------|------------|
| LTE 7 | 5        | 20775          | 2502.5          | QPSK       | 1   | 0           | 23.5        | 28.3       |
|       |          |                |                 |            |     | 12          | 23.5        | 28.2       |
|       |          |                |                 |            |     | 24          | 23.4        | 28.9       |
|       |          |                |                 |            | 12  | 0           | 22.7        | 28.1       |
|       |          |                |                 |            |     | 6           | 22.6        | 28.0       |
|       |          |                |                 |            |     | 11          | 22.6        | 27.9       |
|       |          |                |                 | 16QAM      | 1   | 0           | 22.6        | 28.0       |
|       |          |                |                 |            |     | 12          | 22.7        | 28.1       |
|       |          |                |                 |            |     | 24          | 22.8        | 27.9       |
|       |          |                |                 |            | 12  | 0           | 21.8        | 28.1       |
|       |          |                |                 |            |     | 6           | 21.7        | 28.0       |
|       |          |                |                 |            |     | 11          | 21.7        | 28.0       |
|       |          | 21100          | 2535.0          | QPSK       | 1   | 0           | 23.5        | 28.0       |
|       |          |                |                 |            |     | 12          | <b>23.6</b> | 28.2       |
|       |          |                |                 |            |     | 24          | 23.3        | 28.3       |
|       |          |                |                 |            | 12  | 0           | 22.6        | 27.9       |
|       |          |                |                 |            |     | 6           | 22.6        | 28.0       |
|       |          |                |                 |            |     | 11          | 22.6        | 28.1       |
|       |          |                |                 | 16QAM      | 1   | 0           | 22.6        | 27.6       |
|       |          |                |                 |            |     | 12          | <b>22.8</b> | 28.2       |
|       |          |                |                 |            |     | 24          | 22.6        | 28.3       |
|       |          |                |                 |            | 12  | 0           | 21.7        | 27.9       |
|       |          |                |                 |            |     | 6           | 21.7        | 28.0       |
|       |          |                |                 |            |     | 11          | 21.7        | 28.1       |
|       |          | 21425          | 2567.5          | QPSK       | 1   | 0           | 23.3        | 27.8       |
|       |          |                |                 |            |     | 12          | 23.4        | 28.0       |
|       |          |                |                 |            |     | 24          | 23.1        | 28.1       |
|       |          |                |                 |            | 12  | 0           | 22.5        | 28.3       |
|       |          |                |                 |            |     | 6           | 22.5        | 28.4       |
|       |          |                |                 |            |     | 11          | 22.5        | 28.4       |
|       |          |                |                 | 16QAM      | 1   | 0           | <b>22.5</b> | 28.1       |
|       |          |                |                 |            |     | 12          | 22.4        | 28.2       |
|       |          |                |                 |            |     | 24          | 22.6        | 28.3       |
|       |          |                |                 |            | 12  | 0           | 22.4        | 28.2       |
|       |          |                |                 |            |     | 6           | 21.6        | 28.3       |
|       |          |                |                 |            |     | 11          | <b>21.6</b> | 28.4       |
| 25    | 0        | 21.7           | 28.4            |            |     |             |             |            |
| 25    | 0        | 21.6           | 28.6            |            |     |             |             |            |

**Min Values**
**Max Values**

| Band  | BW [MHz] | Channel Number | Frequency [MHz] | Modulation | #RB  | RB position | Avg [dBm]   | Peak [dBm] |
|-------|----------|----------------|-----------------|------------|------|-------------|-------------|------------|
| LTE 7 | 10       | 20800          | 2505.0          | QPSK       | 1    | 0           | <b>23.7</b> | 28.2       |
|       |          |                |                 |            |      | 24          | 23.7        | 27.7       |
|       |          |                |                 |            |      | 49          | 23.5        | 27.5       |
|       |          |                |                 |            | 25   | 0           | 22.7        | 28.0       |
|       |          |                |                 |            |      | 12          | 22.6        | 27.9       |
|       |          |                |                 |            |      | 24          | 22.6        | 27.8       |
|       |          |                |                 | 50         | 0    | 22.6        | 28.1        |            |
|       |          |                |                 | 16QAM      | 1    | 0           | 22.7        | 28.2       |
|       |          |                |                 |            |      | 24          | 22.7        | 27.9       |
|       |          |                |                 |            |      | 49          | 22.5        | 27.6       |
|       |          |                |                 |            | 25   | 0           | 21.8        | 28.2       |
|       |          |                |                 |            |      | 12          | 21.8        | 28.0       |
|       |          | 24             | 21.7            |            |      | 27.9        |             |            |
|       |          | 50             | 0               | 21.7       | 28.2 |             |             |            |
|       |          | 21100          | 2535.0          | QPSK       | 1    | 0           | 23.6        | 27.7       |
|       |          |                |                 |            |      | 24          | 23.6        | 28.2       |
|       |          |                |                 |            |      | 49          | 23.4        | 28.4       |
|       |          |                |                 |            | 25   | 0           | 22.7        | 27.9       |
|       |          |                |                 |            |      | 12          | 22.7        | 28.1       |
|       |          |                |                 |            |      | 24          | 22.6        | 28.2       |
|       |          |                |                 | 50         | 0    | 22.7        | 28.3        |            |
|       |          |                |                 | 16QAM      | 1    | 0           | 22.9        | 27.6       |
|       |          |                |                 |            |      | 24          | <b>22.9</b> | 28.1       |
|       |          |                |                 |            |      | 49          | 22.6        | 28.3       |
|       |          |                |                 |            | 25   | 0           | 21.8        | 27.9       |
|       |          |                |                 |            |      | 12          | 21.7        | 28.2       |
|       |          | 24             | 21.7            |            |      | 28.3        |             |            |
|       |          | 50             | 0               | 21.7       | 28.3 |             |             |            |
|       |          | 21400          | 2565.0          | QPSK       | 1    | 0           | 23.5        | 28.3       |
|       |          |                |                 |            |      | 24          | 23.5        | 28.2       |
|       |          |                |                 |            |      | 49          | 23.2        | 28.2       |
|       |          |                |                 |            | 25   | 0           | 22.6        | 28.5       |
|       |          |                |                 |            |      | 12          | 22.6        | 28.5       |
|       |          |                |                 |            |      | 24          | <b>22.5</b> | 28.6       |
|       |          |                |                 | 50         | 0    | 22.5        | 28.7        |            |
|       |          |                |                 | 16QAM      | 1    | 0           | 22.8        | 28.6       |
| 24    | 22.8     |                |                 |            |      | 28.5        |             |            |
| 49    | 22.6     |                |                 |            |      | 28.5        |             |            |
| 25    | 0        |                |                 |            | 21.6 | 28.4        |             |            |
|       | 12       |                |                 |            | 21.6 | 28.5        |             |            |
|       | 24       | <b>21.6</b>    | 28.5            |            |      |             |             |            |
| 50    | 0        | 21.6           | 28.8            |            |      |             |             |            |

Min Values  
Max Values

| Band  | BW [MHz] | Channel Number | Frequency [MHz] | Modulation | #RB  | RB position | Avg [dBm] | Peak [dBm] |
|-------|----------|----------------|-----------------|------------|------|-------------|-----------|------------|
| LTE 7 | 15       | 20825          | 2507.5          | QPSK       | 1    | 0           | 23.4      | 27.7       |
|       |          |                |                 |            |      | 37          | 23.4      | 27.3       |
|       |          |                |                 |            |      | 74          | 23.5      | 27.2       |
|       |          |                |                 | 36         | 75   | 0           | 22.7      | 27.7       |
|       |          |                |                 |            |      | 16          | 22.6      | 27.6       |
|       |          |                |                 |            |      | 35          | 22.6      | 27.5       |
|       |          |                |                 | 16QAM      | 1    | 0           | 22.6      | 27.5       |
|       |          |                |                 |            |      | 37          | 22.7      | 28.1       |
|       |          |                |                 |            |      | 74          | 22.4      | 27.5       |
|       |          | 36             | 0               |            | 21.8 | 28.0        |           |            |
|       |          |                | 16              |            | 21.7 | 28.2        |           |            |
|       |          |                | 35              |            | 21.7 | 28.2        |           |            |
|       |          | 75             | 0               | 21.7       | 27.9 |             |           |            |
|       |          | 21100          | 2535.0          | QPSK       | 1    | 0           | 23.4      | 27.4       |
|       |          |                |                 |            |      | 37          | 23.4      | 28.1       |
|       |          |                |                 |            |      | 74          | 23.0      | 28.3       |
|       |          |                |                 | 36         | 75   | 0           | 22.7      | 27.6       |
|       |          |                |                 |            |      | 16          | 22.6      | 28.0       |
|       |          |                |                 |            |      | 35          | 22.6      | 28.2       |
|       |          |                |                 | 16QAM      | 1    | 0           | 22.6      | 27.9       |
|       |          |                |                 |            |      | 37          | 22.6      | 27.4       |
|       |          |                |                 |            |      | 74          | 22.5      | 28.1       |
|       |          | 36             | 0               |            | 22.2 | 28.3        |           |            |
|       |          |                | 16              |            | 21.9 | 27.7        |           |            |
|       |          |                | 35              |            | 21.7 | 28.0        |           |            |
|       |          | 75             | 0               | 21.7       | 28.2 |             |           |            |
|       |          | 21375          | 2562.5          | QPSK       | 1    | 0           | 23.2      | 27.8       |
|       |          |                |                 |            |      | 37          | 23.2      | 27.8       |
|       |          |                |                 |            |      | 74          | 22.9      | 27.4       |
|       |          |                |                 | 36         | 75   | 0           | 22.6      | 28.0       |
| 16    | 22.5     |                |                 |            |      | 27.9        |           |            |
| 35    | 22.5     |                |                 |            |      | 27.7        |           |            |
| 16QAM | 1        |                |                 | 0          | 22.5 | 27.7        |           |            |
|       |          |                |                 | 37         | 22.6 | 28.2        |           |            |
|       |          |                |                 | 74         | 22.6 | 27.8        |           |            |
|       | 36       | 0              | 22.2            | 27.9       |      |             |           |            |
|       |          | 16             | 21.8            | 28.3       |      |             |           |            |
|       |          | 35             | 21.6            | 28.1       |      |             |           |            |
| 75    | 0        | 21.6           | 28.1            |            |      |             |           |            |
| 75    | 0        | 21.6           | 28.0            |            |      |             |           |            |

Min Values

Max Values

| Band  | BW [MHz] | Channel Number | Frequency [MHz] | Modulation | #RB  | RB position | Avg [dBm]   | Peak [dBm] |             |      |
|-------|----------|----------------|-----------------|------------|------|-------------|-------------|------------|-------------|------|
| LTE 7 | 20       | 20850          | 2510.0          | QPSK       | 1    | 0           | 23.0        | 27.3       |             |      |
|       |          |                |                 |            |      | 49          | 23.4        | 27.0       |             |      |
|       |          |                |                 |            |      | 99          | 22.6        | 26.7       |             |      |
|       |          |                |                 | QPSK       | 50   | 0           | 22.8        | 27.4       |             |      |
|       |          |                |                 |            |      | 24          | 22.6        | 27.3       |             |      |
|       |          |                |                 |            |      | 49          | 22.6        | 27.2       |             |      |
|       |          |                |                 | QPSK       | 100  | 0           | 22.6        | 27.2       |             |      |
|       |          |                |                 |            |      | 16QAM       | 1           | 0          | 22.4        | 27.5 |
|       |          |                |                 |            |      |             |             | 49         | <b>22.8</b> | 28.0 |
|       |          | 99             | 21.9            | 26.9       |      |             |             |            |             |      |
|       |          | 16QAM          | 50              | 0          | 21.8 | 27.9        |             |            |             |      |
|       |          |                |                 | 24         | 21.7 | 28.2        |             |            |             |      |
|       |          |                |                 | 49         | 21.7 | 28.3        |             |            |             |      |
|       |          | 16QAM          | 100             | 0          | 21.7 | 27.8        |             |            |             |      |
|       |          |                |                 | QPSK       | 1    | 0           | 23.0        | 27.0       |             |      |
|       |          |                |                 |            |      | 49          | <b>23.4</b> | 28.1       |             |      |
|       |          | 99             | 22.5            |            |      | 28.1        |             |            |             |      |
|       |          | QPSK           | 50              | 0          | 22.7 | 27.5        |             |            |             |      |
|       |          |                |                 | 24         | 22.6 | 28.1        |             |            |             |      |
|       |          |                |                 | 49         | 22.5 | 28.2        |             |            |             |      |
|       |          | QPSK           | 100             | 0          | 22.6 | 27.8        |             |            |             |      |
|       |          |                |                 | 16QAM      | 1    | 0           | 22.2        | 27.5       |             |      |
|       |          |                |                 |            |      | 49          | 22.6        | 28.2       |             |      |
|       |          | 99             | 21.7            |            |      | 28.3        |             |            |             |      |
|       |          | 16QAM          | 50              | 0          | 21.8 | 27.6        |             |            |             |      |
|       |          |                |                 | 24         | 21.6 | 28.0        |             |            |             |      |
|       |          |                |                 | 49         | 21.5 | 28.3        |             |            |             |      |
| 16QAM | 100      | 0              | 21.6            | 28.0       |      |             |             |            |             |      |
|       |          | QPSK           | 1               | 0          | 23.0 | 28.0        |             |            |             |      |
|       |          |                |                 | 49         | 23.3 | 28.0        |             |            |             |      |
| 99    | 22.4     |                |                 | 27.2       |      |             |             |            |             |      |
| QPSK  | 50       | 0              | 22.6            | 28.4       |      |             |             |            |             |      |
|       |          | 24             | 22.4            | 28.3       |      |             |             |            |             |      |
|       |          | 49             | <b>22.4</b>     | 27.8       |      |             |             |            |             |      |
| QPSK  | 100      | 0              | 22.5            | 27.9       |      |             |             |            |             |      |
|       |          | 16QAM          | 1               | 0          | 22.2 | 28.5        |             |            |             |      |
|       |          |                |                 | 49         | 22.5 | 28.1        |             |            |             |      |
| 99    | 22.3     |                |                 | 27.8       |      |             |             |            |             |      |
| 16QAM | 50       | 0              | 21.8            | 28.6       |      |             |             |            |             |      |
|       |          | 24             | 21.6            | 28.3       |      |             |             |            |             |      |
|       |          | 49             | <b>21.5</b>     | 28.1       |      |             |             |            |             |      |
| 16QAM | 100      | 0              | 21.6            | 28.5       |      |             |             |            |             |      |

**Min Values**
**Max Values**

| Band   | BW [MHz]    | Channel Number | Frequency [MHz] | Modulation | #RB  | RB position | Avg [dBm]   | Peak [dBm] |
|--------|-------------|----------------|-----------------|------------|------|-------------|-------------|------------|
| LTE 41 | 5           | 39675          | 2498.5          | QPSK       | 1    | 0           | 22.2        | 27.8       |
|        |             |                |                 |            |      | 12          | 22.2        | 27.6       |
|        |             |                |                 |            |      | 24          | 22.1        | 27.8       |
|        |             |                |                 |            | 12   | 0           | 21.3        | 27.4       |
|        |             |                |                 |            |      | 6           | 21.3        | 27.4       |
|        |             |                |                 |            |      | 11          | 21.3        | 27.5       |
|        |             |                |                 | 25         | 0    | <b>21.3</b> | 27.4        |            |
|        |             |                |                 | 16QAM      | 1    | 0           | 21.3        | 27.9       |
|        |             |                |                 |            |      | 12          | 21.3        | 27.8       |
|        |             |                |                 |            |      | 24          | 21.2        | 27.7       |
|        |             |                |                 |            | 12   | 0           | 20.3        | 27.2       |
|        |             |                |                 |            |      | 6           | 20.3        | 27.2       |
|        |             | 11             | <b>20.3</b>     |            |      | 27.1        |             |            |
|        |             | 25             | 0               | 20.3       | 27.3 |             |             |            |
|        |             | 40620          | 2593.0          | QPSK       | 1    | 0           | 22.3        | 28.2       |
|        |             |                |                 |            |      | 12          | <b>22.4</b> | 28.1       |
|        |             |                |                 |            |      | 24          | 22.2        | 28.2       |
|        |             |                |                 |            | 12   | 0           | 21.5        | 27.7       |
|        |             |                |                 |            |      | 6           | 21.4        | 27.7       |
|        |             |                |                 |            |      | 11          | 21.4        | 27.6       |
|        |             |                |                 | 25         | 0    | 21.4        | 27.8        |            |
|        |             |                |                 | 16QAM      | 1    | 0           | 21.5        | 28.0       |
|        |             |                |                 |            |      | 12          | 21.5        | 27.9       |
|        |             |                |                 |            |      | 24          | 21.4        | 28.0       |
|        |             |                |                 |            | 12   | 0           | 20.5        | 27.7       |
|        |             |                |                 |            |      | 6           | 20.4        | 27.7       |
|        |             | 11             | 20.5            |            |      | 27.7        |             |            |
|        |             | 25             | 0               | 20.4       | 27.9 |             |             |            |
|        |             | 41565          | 2687.5          | QPSK       | 1    | 0           | 22.3        | 28.2       |
|        |             |                |                 |            |      | 12          | 22.4        | 28.0       |
|        |             |                |                 |            |      | 24          | 22.2        | 28.1       |
|        |             |                |                 |            | 12   | 0           | 21.5        | 27.9       |
|        |             |                |                 |            |      | 6           | 21.5        | 27.8       |
|        |             |                |                 |            |      | 11          | 21.5        | 27.9       |
|        |             |                |                 | 25         | 0    | 21.5        | 27.8        |            |
|        |             |                |                 | 16QAM      | 1    | 0           | 21.5        | 28.1       |
| 12     | <b>21.6</b> |                |                 |            |      | 28.2        |             |            |
| 24     | 21.4        |                |                 |            |      | 28.1        |             |            |
| 12     | 0           |                |                 |            | 20.5 | 27.7        |             |            |
|        | 6           |                |                 |            | 20.4 | 27.7        |             |            |
|        | 11          | 20.5           | 27.7            |            |      |             |             |            |
| 25     | 0           | 20.5           | 27.8            |            |      |             |             |            |

**Min Values**
**Max Values**

| Band   | BW [MHz] | Channel Number | Frequency [MHz] | Modulation | #RB  | RB position | Avg [dBm]   | Peak [dBm] |
|--------|----------|----------------|-----------------|------------|------|-------------|-------------|------------|
| LTE 41 | 10       | 39700          | 2501.0          | QPSK       | 1    | 0           | 22.4        | 28.0       |
|        |          |                |                 |            |      | 24          | 22.4        | 28.0       |
|        |          |                |                 |            |      | 49          | 22.3        | 28.0       |
|        |          |                |                 |            | 25   | 0           | 21.4        | 27.3       |
|        |          |                |                 |            |      | 12          | 21.4        | 27.4       |
|        |          |                |                 |            |      | 24          | <b>21.3</b> | 27.4       |
|        |          |                |                 | 50         | 0    | 21.4        | 27.4        |            |
|        |          |                |                 | 16QAM      | 1    | 0           | 21.4        | 28.0       |
|        |          |                |                 |            |      | 24          | 21.3        | 27.9       |
|        |          |                |                 |            |      | 49          | 21.2        | 28.0       |
|        |          |                |                 |            | 25   | 0           | 20.4        | 27.4       |
|        |          |                |                 |            |      | 12          | 20.4        | 27.4       |
|        |          | 24             | <b>20.4</b>     |            |      | 27.3        |             |            |
|        |          | 50             | 0               | 20.4       | 27.5 |             |             |            |
|        |          | 40620          | 2593.0          | QPSK       | 1    | 0           | 22.5        | 28.3       |
|        |          |                |                 |            |      | 24          | 22.5        | 28.2       |
|        |          |                |                 |            |      | 49          | 22.3        | 28.3       |
|        |          |                |                 |            | 25   | 0           | 21.6        | 27.9       |
|        |          |                |                 |            |      | 12          | 21.5        | 27.8       |
|        |          |                |                 |            |      | 24          | 21.5        | 27.7       |
|        |          |                |                 | 50         | 0    | 21.5        | 27.9        |            |
|        |          |                |                 | 16QAM      | 1    | 0           | 21.7        | 28.3       |
|        |          |                |                 |            |      | 24          | 21.6        | 28.2       |
|        |          |                |                 |            |      | 49          | 21.4        | 28.5       |
|        |          |                |                 |            | 25   | 0           | 20.5        | 27.8       |
|        |          |                |                 |            |      | 12          | 20.5        | 27.7       |
|        |          | 24             | 20.4            |            |      | 27.8        |             |            |
|        |          | 50             | 0               | 20.5       | 27.9 |             |             |            |
|        |          | 41540          | 2685.0          | QPSK       | 1    | 0           | <b>22.7</b> | 28.4       |
|        |          |                |                 |            |      | 24          | 22.6        | 28.3       |
|        |          |                |                 |            |      | 49          | 22.5        | 28.3       |
|        |          |                |                 |            | 25   | 0           | 21.7        | 27.8       |
|        |          |                |                 |            |      | 12          | 21.6        | 27.8       |
|        |          |                |                 |            |      | 24          | 21.5        | 27.7       |
|        |          |                |                 | 50         | 0    | 21.6        | 27.8        |            |
|        |          |                |                 | 16QAM      | 1    | 0           | <b>21.7</b> | 28.4       |
| 24     | 21.6     |                |                 |            |      | 28.2        |             |            |
| 49     | 21.4     |                |                 |            |      | 28.3        |             |            |
| 25     | 0        |                |                 |            | 20.6 | 27.8        |             |            |
|        | 12       |                |                 |            | 20.6 | 27.7        |             |            |
|        | 24       | 20.5           | 27.7            |            |      |             |             |            |
| 50     | 0        | 20.6           | 27.9            |            |      |             |             |            |

Min Values  
Max Values

| Band   | BW [MHz] | Channel Number | Frequency [MHz] | Modulation | #RB   | RB position | Avg [dBm]   | Peak [dBm] |      |             |      |
|--------|----------|----------------|-----------------|------------|-------|-------------|-------------|------------|------|-------------|------|
| LTE 41 | 15       | 39725          | 2503.5          | QPSK       | 1     | 0           | 22.3        | 27.9       |      |             |      |
|        |          |                |                 |            |       | 37          | 22.3        | 27.8       |      |             |      |
|        |          |                |                 |            |       | 74          | 22.0        | 27.9       |      |             |      |
|        |          |                |                 |            | 36    | 0           | 21.6        | 27.5       |      |             |      |
|        |          |                |                 |            |       | 16          | 21.4        | 27.5       |      |             |      |
|        |          |                |                 |            |       | 35          | <b>21.4</b> | 27.5       |      |             |      |
|        |          |                |                 | 75         | 0     | 21.4        | 27.6        |            |      |             |      |
|        |          |                |                 | 16QAM      | 1     | 0           | 21.1        | 27.6       |      |             |      |
|        |          |                |                 |            |       | 37          | 21.2        | 27.6       |      |             |      |
|        |          |                |                 |            |       | 74          | 20.9        | 27.9       |      |             |      |
|        |          |                |                 |            | 36    | 0           | 20.6        | 27.5       |      |             |      |
|        |          |                |                 |            |       | 16          | 20.4        | 27.5       |      |             |      |
|        |          | 35             | <b>20.4</b>     |            |       | 27.5        |             |            |      |             |      |
|        |          | 75             | 0               | 20.4       | 27.7  |             |             |            |      |             |      |
|        |          | 40620          | 2593.0          | QPSK       | 1     | 0           | 22.3        | 28.3       |      |             |      |
|        |          |                |                 |            |       | 37          | 22.3        | 28.2       |      |             |      |
|        |          |                |                 |            |       | 74          | 22.0        | 28.2       |      |             |      |
|        |          |                |                 |            | 36    | 0           | 21.7        | 27.9       |      |             |      |
|        |          |                |                 |            |       | 16          | 21.5        | 27.8       |      |             |      |
|        |          |                |                 |            |       | 35          | 21.5        | 27.9       |      |             |      |
|        |          |                |                 |            | 75    | 0           | 21.6        | 27.9       |      |             |      |
|        |          |                |                 |            | 16QAM | 1           | 0           | 21.4       | 28.1 |             |      |
|        |          |                |                 |            |       |             | 37          | 21.4       | 28.0 |             |      |
|        |          |                |                 | 74         |       |             | 21.0        | 28.0       |      |             |      |
|        |          |                |                 | 36         |       | 0           | 20.7        | 27.8       |      |             |      |
|        |          |                |                 |            |       | 16          | 20.5        | 27.8       |      |             |      |
|        |          |                |                 |            |       | 35          | 20.5        | 27.8       |      |             |      |
|        |          |                |                 | 75         |       | 0           | 20.6        | 27.9       |      |             |      |
|        |          |                |                 | 41515      |       | 2682.5      | QPSK        | 1          | 0    | <b>22.4</b> | 28.4 |
|        |          |                |                 |            |       |             |             |            | 37   | 22.4        | 28.3 |
| 74     | 22.1     |                |                 |            | 28.3  |             |             |            |      |             |      |
| 36     | 0        |                |                 |            | 21.7  |             |             | 27.9       |      |             |      |
|        | 16       | 21.5           | 27.9            |            |       |             |             |            |      |             |      |
|        | 35       | 21.5           | 27.9            |            |       |             |             |            |      |             |      |
| 75     | 0        | 21.6           | 27.9            |            |       |             |             |            |      |             |      |
| 16QAM  | 1        | 0              | <b>21.6</b>     |            | 28.4  |             |             |            |      |             |      |
|        |          | 37             | 21.5            |            | 28.3  |             |             |            |      |             |      |
|        |          | 74             | 21.2            | 28.3       |       |             |             |            |      |             |      |
|        | 36       | 0              | 20.7            | 27.9       |       |             |             |            |      |             |      |
|        |          | 16             | 20.5            | 27.9       |       |             |             |            |      |             |      |
|        |          | 35             | 20.5            | 27.9       |       |             |             |            |      |             |      |
| 75     | 0        | 20.5           | 27.9            |            |       |             |             |            |      |             |      |

**Min Values**
**Max Values**

| Band   | BW [MHz] | Channel Number | Frequency [MHz] | Modulation  | #RB   | RB position | Avg [dBm]   | Peak [dBm]  |      |
|--------|----------|----------------|-----------------|-------------|-------|-------------|-------------|-------------|------|
| LTE 41 | 20       | 39750          | 2506.0          | QPSK        | 1     | 0           | 21.9        | 27.5        |      |
|        |          |                |                 |             |       | 49          | 22.2        | 27.7        |      |
|        |          |                |                 |             |       | 99          | 21.5        | 27.3        |      |
|        |          |                |                 |             | 50    | 0           | 21.6        | 27.5        |      |
|        |          |                |                 |             |       | 24          | 21.5        | 21.4        |      |
|        |          |                |                 |             |       | 49          | <b>21.4</b> | 27.5        |      |
|        |          |                |                 |             | 100   | 0           | 21.5        | 27.5        |      |
|        |          |                |                 |             | 16QAM | 1           | 0           | 20.9        | 27.6 |
|        |          |                |                 |             |       |             | 49          | 21.2        | 27.6 |
|        |          | 99             | 20.5            | 27.4        |       |             |             |             |      |
|        |          | 50             | 0               | 20.5        |       | 27.5        |             |             |      |
|        |          |                | 24              | 20.4        |       | 27.5        |             |             |      |
|        |          |                | 49              | <b>20.4</b> |       | 27.4        |             |             |      |
|        |          | 100            | 0               | 20.4        |       | 27.6        |             |             |      |
|        |          | 40620          | 2593.0          | QPSK        |       | 1           | 0           | 22.1        | 28.1 |
|        |          |                |                 |             |       |             | 49          | <b>22.3</b> | 28.1 |
|        |          |                |                 |             | 99    |             | 21.6        | 28.0        |      |
|        |          |                |                 |             | 50    | 0           | 21.7        | 28.0        |      |
|        | 24       |                |                 |             |       | 21.5        | 27.9        |             |      |
|        | 49       |                |                 |             |       | 21.4        | 27.9        |             |      |
|        | 100      |                |                 |             | 0     | 21.5        | 28.1        |             |      |
|        | 16QAM    |                |                 |             | 1     | 0           | 21.0        | 28.5        |      |
|        |          |                |                 |             |       | 49          | 21.3        | 28.4        |      |
|        |          |                | 99              | 20.5        |       | 28.4        |             |             |      |
|        |          |                | 50              | 0           | 20.7  | 27.8        |             |             |      |
|        |          |                |                 | 24          | 20.5  | 27.8        |             |             |      |
|        |          |                |                 | 49          | 20.4  | 27.8        |             |             |      |
|        |          |                | 100             | 0           | 20.5  | 27.9        |             |             |      |
|        |          |                | 41490           | 2680.0      | QPSK  | 1           | 0           | 22.1        | 28.1 |
|        |          |                |                 |             |       |             | 49          | 22.3        | 28.1 |
|        | 99       |                |                 |             |       |             | 21.6        | 27.8        |      |
|        | 50       |                |                 |             |       | 0           | 21.7        | 27.9        |      |
|        |          | 24             |                 |             |       | 21.5        | 27.8        |             |      |
|        |          | 49             |                 |             |       | 21.5        | 27.8        |             |      |
|        | 100      | 0              |                 |             |       | 21.6        | 27.9        |             |      |
|        | 16QAM    | 1              |                 |             |       | 0           | 21.4        | 27.9        |      |
| 49     |          |                |                 |             |       | <b>21.5</b> | 28.0        |             |      |
| 99     |          |                |                 | 21.1        | 27.6  |             |             |             |      |
| 50     |          | 0              |                 | 20.7        | 27.9  |             |             |             |      |
|        |          | 24             |                 | 20.5        | 27.8  |             |             |             |      |
|        |          | 49             |                 | 20.5        | 27.8  |             |             |             |      |
| 100    |          | 0              |                 | 20.5        | 28.0  |             |             |             |      |

Min Values  
Max Values