

# FCC Test Report (Part 22&24&27)

Product Name : Intel 7260M2NA  
Model No : 7260M2NA  
FCC ID : PD97260NA

Applicant : Intel Mobile Communications

Address : 100 Center Point Circle, Suite 200 Columbia, South Carolina 29210 USA

Date of Receipt : 2014/09/12  
Issued Date : 2014/11/03  
Report No. : 1490343R-HPUSP11V00  
Report Version : V1.0



The test results relate only to the samples tested.

The test results shown in the test report are traceable to the national/international standard through the calibration of the equipment and evaluated measurement uncertainty herein.

This report must not be used to claim product endorsement by TAF or any agency of the government.

The test report shall not be reproduced without the written approval of Quietek Corporation.

# Test Report

Issued Date : 2014/11/03

Report No.: 1490343R-HPUSP11V00



Product Name : Intel 7260M2NA

Applicant : Intel Mobile Communications

Address : 100 Center Point Circle, Suite 200 Columbia, South Carolina 29210 USA

Manufacturer : Intel Mobile Communications

Trade Name : Intel

Model No. : 7260M2NA

EUT Rated Voltage : DC 3.3V

EUT Test Voltage : DC 3.3V

Measurement Standard : FCC CFR Title 47 Part 2 22 24 27

Measurement : TIA/EIA 603-C

Reference :

Test Result : Complied

Documented By : Anny Chou  
 (Adm. Specialist / Anny Chou)

Tested By : Vorana Chen  
 (Senior Engineer / Vorana Chen)

Approved By : Vincent Lin  
 (Director / Vincent Lin)

**TABLE OF CONTENTS**

Description	Page
1. GENERAL INFORMATION .....	4
1.1. EUT Description .....	4
1.2. Antenna List.....	4
1.3. Operational Description.....	5
1.4. Configuration of tested System .....	6
1.5. EUT Setup Procedures .....	6
1.6. Test Facility .....	7
1.7. Type of Emission .....	8
1.8. Voltages and DC currents .....	8
2. Technical Test .....	9
2.1. Summary of test result .....	9
2.2. List of test Equipment.....	10
2.3. Measurement Uncertainty.....	10
3. Conducted Output Power Measurement .....	11
3.1. Test Specification .....	11
3.2. Test Setup .....	11
3.3. Limits .....	11
3.4. Test Procedure .....	11
3.5. Test Result of Maximum Power Output.....	12
4. Occupied Bandwidth.....	13
4.1. Test Specification .....	13
4.2. Test Setup .....	13
4.3. Test Procedure .....	13
4.4. Test Result of Occupied Bandwidth .....	14
5. Spurious Emission At Antenna Terminals (+/-1MHz) .....	29
5.1. Test Specification .....	29
5.2. Setup .....	29
5.3. Limits .....	29
5.4. Test Procedure .....	29
5.5. Test Result of Spurious Emission At Antenna Terminals (+/-1MHz).....	30
6. Spurious Emission .....	37
6.1. Test Specification .....	37
6.2. Test Setup .....	37
6.3. Limits .....	38
6.4. Test Procedure .....	38
6.5. Test Result of Spurious Emission .....	39
7. Frequency Stability Under Temperature & Voltage Variations .....	67
7.1. Test Specification .....	67
7.2. Test Setup .....	67
7.3. Limits .....	67
7.4. Test Procedure .....	67
7.5. Test Result of Frequency Stability Under Temperature Variations.....	68
7. EMI Reduction Method During Compliance Testing.....	75
Attachment 1: EUT Test Photographs	
Attachment 2: EUT Detailed Photographs	

**1. GENERAL INFORMATION**

**1.1. EUT Description**

Product Name	Intel 7260M2NA
Model No.	7260M2NA
Trade Name	Intel
IMEI No.	004402478916806
FCC ID	PD97260NA
Antenna Type	Dipole
TX Frequency	GSM850: 824.2 MHz ~ 848.8 MHz GSM1900: 1850.2 MHz ~ 1909.8MHz WCDMA Band 2: 1852.4 MHz ~ 1907.6 MHz WCDMA Band 4: 1712.4 MHz ~ 1752.6 MHz WCDMA Band 5: 826.4 MHz ~ 846.6 MHz
Rx Frequency	GSM850: 869.2 MHz ~ 893.8 MHz GSM1900: 1930.2 MHz ~ 1989.8 MHz WCDMA Band 2: 1932.4 MHz ~ 1987.6 MHz WCDMA Band 4: 2112.4 MHz ~ 2152.6 MHz WCDMA Band 5: 871.4 MHz ~ 891.6 MHz
Type of modulation	GPRS: GMSK; EGPRS: GMSK / 8PSK WCDMA: QPSK (Uplink); HSDPA: QPSK (Uplink); HSUPA: QPSK (Uplink)
HW Version	PR3.1
SW version	1433

**1.2. Antenna List**

No.	Manufacturer	Part No.	Peak Gain
1	Pulse	SPDA24700/2700	2dBi

**1.3. Operational Description**

The information contained within this report is intended to show verification of compliance of the 700/850/1700/1900MHz to the requirements of FCC 47 CFR Part 2, 22, 24 and 27

The EUT provide all functions described as above. The EUT is tested with maximum rated TX power via the Base Station simulator.

QuieTek has verified the construction and function in typical operation. All the test modes were carried out with the EUT in normal operation, which was shown in this test report and defined

as:

Test Mode:	GSM 850 GPRS
	GSM 850 EGPRS
	PCS 1900 GPRS
	PCS 1900 EGPRS
	WCDMA BAND 2 (RMC/HSDPA/HSUPA)
	WCDMA BAND 4 (RMC/HSDPA/HSUPA)
	WCDMA BAND 5 (RMC/HSDPA/HSUPA)

Note:

The maximum power levels are GPRS class8 mode for GSM 850/1900, EGPRS class8 mode for GSM 850/1900, RMC 12.2K mode for WCDMA Band 2/4/5, only these modes were used for all tests.

## 1.4. Configuration of tested System

- (a) Configuration of Radiated measurement

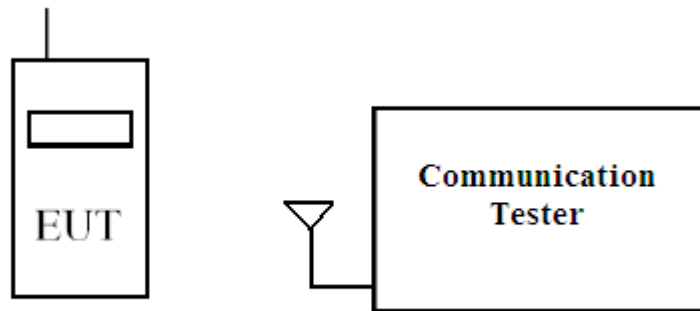

- (b) Configuration of Conducted measurement

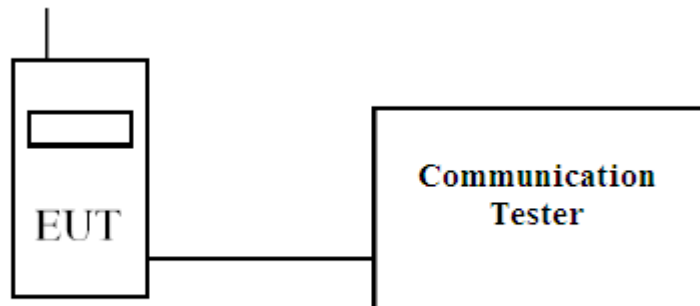

## 1.5. EUT Setup Procedures

- (1) Setup the EUT and simulators as shown on 1.3
- (2) Turn on the power of all equipments.
- (3) The EUT was set to communicate with communication tester.
- (4) Repeat the above procedure (3).

**1.6. Test Facility**

Ambient conditions in the laboratory:

Items	Required (IEC 68-1)	Actual
Temperature (°C)	15-35	23
Humidity (%RH)	25-75	55
Barometric pressure (mbar)	860-1060	982

Site Description: File on  
Federal Communications Commission  
FCC Engineering Laboratory  
7435 Oakland Mills Road  
Columbia, MD 21046  
FCC Registration Number :92195

Site Name: Quietek Corporation

Linkou Testing Laboratory:  
No.5-22, Ruishukeng, Linkou Dist.,  
New Taipei City 24451,  
Taiwan, R.O.C.  
TEL : 886-2-8601-3788 / FAX : 886-2-8601-3789  
E-Mail : [service@quietek.com](mailto:service@quietek.com)

FCC Accreditation Number: TW1014

**1.7. Type of Emission**

System	Type of modulation	Emission Designator
GSM850 GPRS class 8	GMSK	243KGXW
GSM850 EGPRS class 8	8PSK	259KG7W
GSM1900 GPRS class 8	GMSK	247KGXW
GSM1900 EGPRS class 8	8PSK	265KG7W
WCDMA Band 2 RMC 12.2kbps	QPSK	4M94F9W
WCDMA Band 4 RMC 12.2kbps	QPSK	4M87F9W
WCDMA Band 5 RMC 12.2kbps	QPSK	4M81F9W

**1.8. Voltages and DC currents**

<b>GSM 850 GPRS</b>	
EUT Transmitting (in maximum power) :	DC voltage : 3.3V , DC current : 0.20A
EUT Standby :	DC voltage : 3.3V , DC current : 0.04A
<b>GSM 850 EGPRS</b>	
EUT Transmitting (in maximum power) :	DC voltage : 3.3V , DC current : 0.20A
EUT Standby :	DC voltage : 3.3V , DC current : 0.04A
<b>PCS 1900 GPRS</b>	
EUT Transmitting (in maximum power) :	DC voltage : 3.7V , DC current : 0.22A
EUT Standby :	DC voltage : 3.7V , DC current : 0.04A
<b>PCS 1900 EGPRS</b>	
EUT Transmitting (in maximum power) :	DC voltage : 3.7V , DC current : 0.22A
EUT Standby :	DC voltage : 3.7V , DC current : 0.04A
<b>WCDMA Band 2 RMC 12.2K</b>	
EUT Transmitting (in maximum power) :	DC voltage : 3.3V , DC current : 0.69A
EUT Standby :	DC voltage : 3.3V , DC current : 0.03A
<b>WCDMA Band 4 RMC 12.2K</b>	
EUT Transmitting (in maximum power) :	DC voltage : 3.3V , DC current : 0.69A
EUT Standby :	DC voltage : 3.3V , DC current : 0.03A
<b>WCDMA Band 5 RMC 12.2K</b>	
EUT Transmitting (in maximum power) :	DC voltage : 3.3V , DC current : 0.56A
EUT Standby :	DC voltage : 3.3V , DC current : 0.03A



**2. Technical Test**

**2.1. Summary of test result**

Standard	Test Item	Result	Note
2.1046	Conducted Output Power	Pass	
22.913(a)			
24.232(c)			
27.5			
2.1049	Occupied Bandwidth	Pass	
22.917(a)			
24.238(b)			
27.53(g)			
2.1051	Spurious Emission at Antenna Terminals	Pass	
22.917(a)			
24.238(a)			
27.53(g)			
2.1051	Conducted Emission	Pass	
22.917(a)			
24.238(a)			
27.53(g)			
2.1053	Field Strength of Spurious Radiation	Pass	
22.917(a)			
24.238(a)			
27.53(g)			
2.1055	Frequency Stability for Temperature & Voltage	Pass	
22.355			
24.235			
27.54			

## 2.2. List of test Equipment

Conducted /CTR

Instrument	Manufacturer	Type No.	Serial No	Cal. Date
Spectrum Analyzer	Agilent	N9010A	MY52220597	2014/05/13
Directional coupler	Agilent	87300C	MY44300353	2013/11/04
Directional coupler	Agilent	778D-012	50550	2013/11/07
Standard Temperature & Humidity Chamber	WIT	TH-1S-B	EQ-201-00146	2014/09/26
DC power supply	Agilent	E3610A	MY40009845	2014/06/18
Communication Tester	R&S	CMU200	104846	2014/05/05
Communication Tester	Agilent	E5515C	GB47390315	2013/12/20

Radiated / Site3

Instrument	Manufacturer	Type No.	Serial No	Cal. Date
Bilog Antenna	Schaffner Chase	CBL6112B	2707	2014/06/13
Horn Antenna	R&S	9120D	556	2013/12/20
Pre-Amplifier	Agilent	87405C	MY47010653	2014/01/13
Spectrum Analyzer	Agilent	N9010A	MY52220597	2014/05/13
Communication Tester	R&S	CMU200	104846	2014/05/05
Communication Tester	Agilent	E5515C	GB47390315	2013/12/20

## 2.3. Measurement Uncertainty

### Conducted Emission

The measurement uncertainty of confidence of 95% is evaluated as  $\pm 1.52$  dB

### Radiated Emission (Below 1GHz)

The measurement uncertainty of confidence of 95% is evaluated as  $\pm 3.44$  dB .

### Radiated Emission (Above 1GHz)

The measurement uncertainty of confidence of 95% is evaluated as  $\pm 4.08$  dB

### 3. Conducted Output Power Measurement

#### 3.1. Test Specification

According to Part 2.1046, 22.913, 24.232, 27.50

#### 3.2. Test Setup

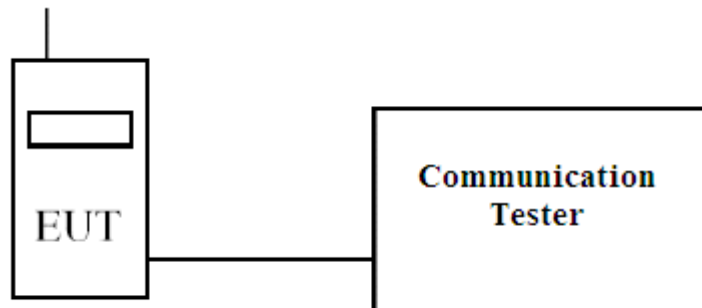

#### 3.3. Limits

Band	Limit
850	<7W
1900	<2W
AWS(1700)	<1W

#### 3.4. Test Procedure

The EUT is tested with maximum rated TX power via the Base Station simulator, and the output power was measured at the antenna terminals of the EUT.

3.5. Test Result of Maximum Power Output

Product	Intel 7260M2NA		
Test Mode	RF Output Power (Conducted)		
Date of Test	2014/10/15	Test Site	CTR

Band	GSM 850			GSM 1900		
	CHANNEL	128	189	251	512	661
GPRS Class 8	32.01	32.02	<b>32.07</b>	<b>29.84</b>	29.8	29.79
GPRS Class 10	31.65	31.78	31.7	29.83	29.75	29.69
GPRS Class 11	31.25	31.29	31.25	29.27	29.22	29.19
GPRS Class 12	30.56	30.58	30.49	28.18	28.13	28.14
EGPRS Class 8	<b>27.54</b>	27.39	27.28	26.27	26.5	<b>26.76</b>
EGPRS Class 10	27.48	27.42	27.36	26.36	26.58	26.67
EGPRS Class 11	26.85	26.83	26.75	25.57	25.88	25.99
EGPRS Class 12	25.74	25.62	25.53	24.31	24.62	24.75

Unit : dBm

Band	WCDMA Band 2			WCDMA Band 4			WCDMA Band 5		
	CHANNEL	9262	9400	9538	1312	1413	1513	4132	4183
RMC	<b>24.66</b>	24.28	24.23	<b>24.54</b>	24.52	24.1	<b>23.88</b>	23.8	23.87
HSDPA Set 1	24.62	24.46	24.27	24.41	24.49	24.09	23.73	23.87	23.79
HSDPA Set 2	24.2	23.97	23.82	23.96	24.01	23.69	23.73	23.83	23.81
HSDPA Set 3	23.61	23.48	23.28	23.48	23.51	23.18	22.8	23.85	22.79
HSDPA Set 4	23.35	23.25	23.01	23.19	23.24	22.97	22.76	23.58	22.56
HSUPA Set 1	23.66	23.58	23.3	23.41	23.53	23.22	22.8	22.17	22.88
HSUPA Set 2	21.81	21.74	21.51	21.63	21.68	21.48	20.92	20.9	20.97
HSUPA Set 3	22.78	22.73	22.41	22.65	22.71	22.4	22.02	21.86	22.09
HSUPA Set 4	22.08	21.9	21.75	21.94	21.93	21.72	21.29	21.28	21.38
HSUPA Set 5	23.57	23.48	23.23	23.36	23.46	23.12	22.74	22.27	22.81

Unit : dBm

**4. Occupied Bandwidth**

**4.1. Test Specification**

According to Part 2.1049, 22.917, 24.238.27.53

**4.2. Test Setup**

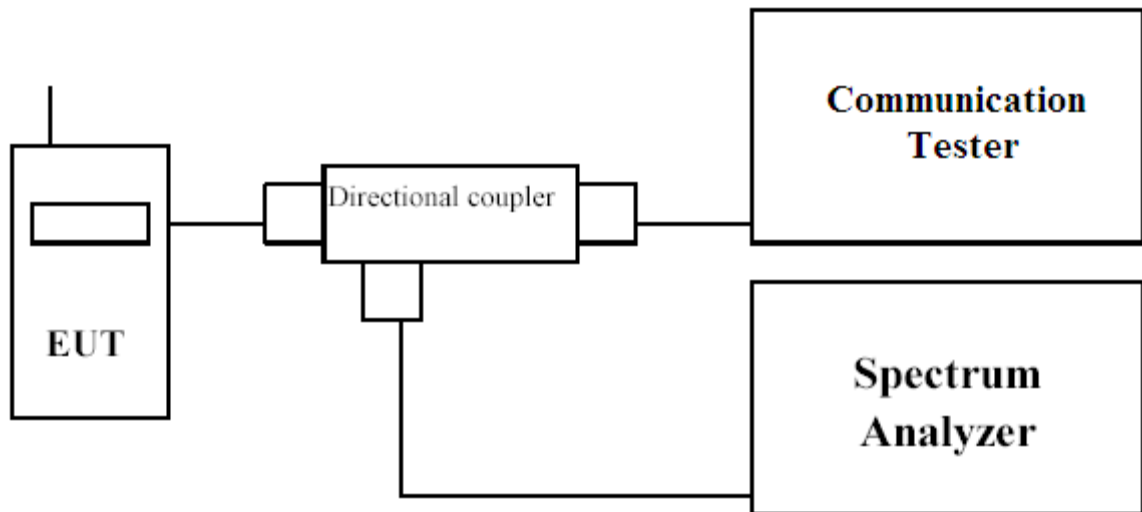

**4.3. Test Procedure**

The EUT is tested with maximum rated TX power via the Base Station simulator, and the occupied bandwidth was measured at the antenna terminals of the EUT.

The Resolution BW of the analyzer is set to 1 % of the emission bandwidth. The EUT's occupied bandwidth is measured as the width of the signal between two points, one below the carrier center frequency and one above the carrier frequency, outside of which all emissions are attenuated at least 26 dB below the transmitter power.

The plots below show the resultant display from the Spectrum Analyzer.

#### 4.4. Test Result of Occupied Bandwidth

Product	Intel 7260M2NA
Test Mode	Occupied Bandwidth
Test Site	CTR

Test Mode	Channel & TX Frequency (MHz)	99% Occupied Bandwidth (kHz)	26 dB bandwidth (kHz)	Required Limit (MHz)	Result
GSM 850 GPRS	128(824.2)	241.74	311.9	N/A	Pass
	189(836.4)	243.26	315.2	N/A	Pass
	251(848.8)	242.16	320.5	N/A	Pass
GSM 850 EGPRS	128(824.2)	254.20	326.2	N/A	Pass
	189(836.4)	254.24	326.7	N/A	Pass
	251(848.8)	259.83	318.2	N/A	Pass
PCS 1900 GPRS	512(1850.2)	246.56	315.2	N/A	Pass
	661(1880)	242.82	317.7	N/A	Pass
	810(1909.8)	247.56	322.6	N/A	Pass
PCS 1900 EGPRS	512(1850.2)	263.47	338.3	N/A	Pass
	661(1880)	265.03	342.8	N/A	Pass
	810(1909.8)	256.48	333.5	N/A	Pass
WCDMA Band 2	9262(1852.4)	4081.8	4679	N/A	Pass
	9400(1880)	4088.0	4688	N/A	Pass
	9538(1907.6)	4094.1	4712	N/A	Pass
WCDMA Band 4	1312(1712.4)	4080.6	4669	N/A	Pass
	1413(1732.6)	4082.9	4666	N/A	Pass
	1513(1752.6)	4087.2	4684	N/A	Pass
WCDMA Band 5	4132(826.4)	4075.3	4661	N/A	Pass
	4183(836.6)	4081.6	4674	N/A	Pass
	4233(846.6)	4078.1	4663	N/A	Pass

Product	Intel 7260M2NA		
Test Mode	Occupied Bandwidth		
Date of Test	2014/09/10	Test Site	CTR
Test Condition	GSM 850 GPRS		

### GSM 850 GPRS - Packet Switched (GSM Mode CH 128)

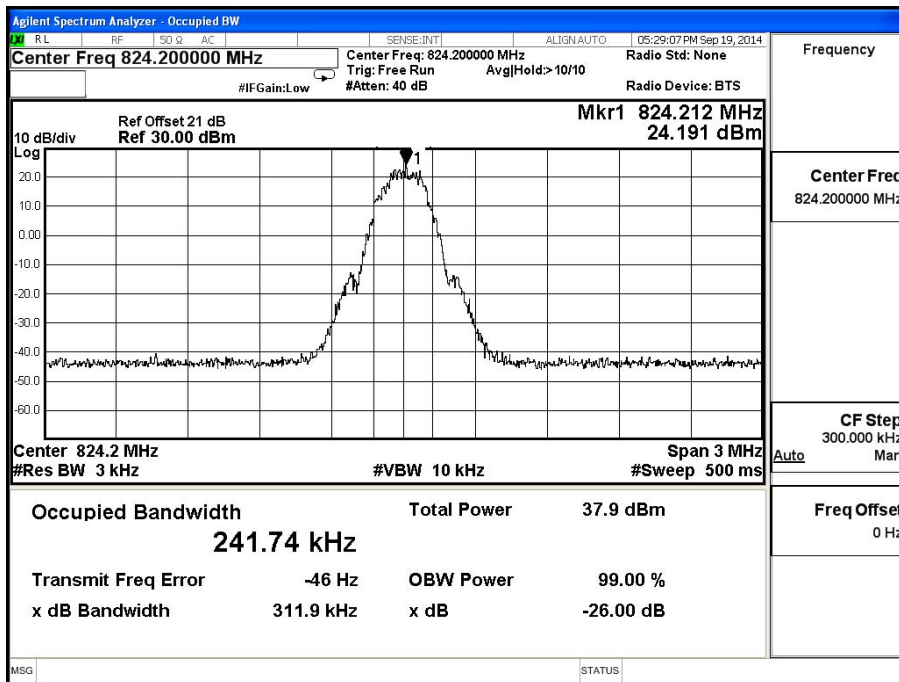

### GSM 850 GPRS - Packet Switched (GSM Mode CH189)

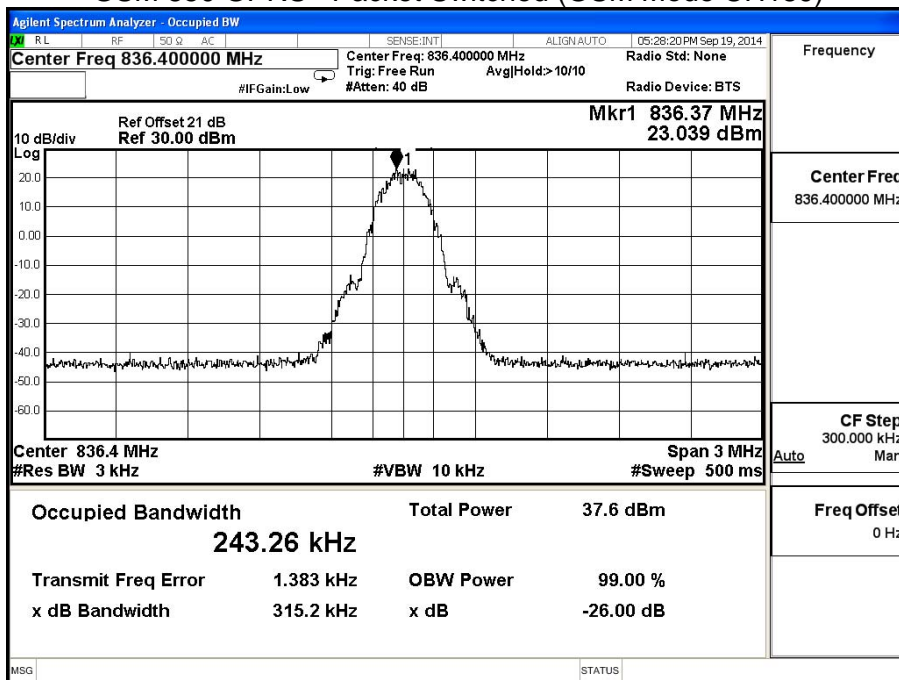

Product	Intel 7260M2NA		
Test Mode	Occupied Bandwidth		
Date of Test	2014/09/10	Test Site	CTR
Test Condition	GSM 850 GPRS		

GSM 850 GPRS - Packet Switched (GSM Mode CH 251)

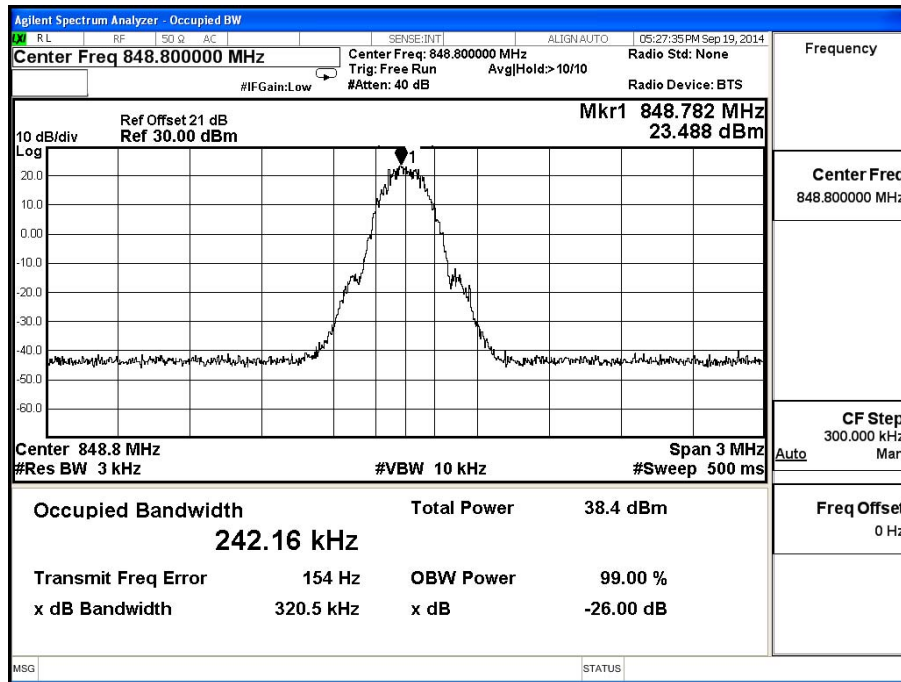



Product	Intel 7260M2NA		
Test Mode	Occupied Bandwidth		
Date of Test	2014/09/10	Test Site	CTR
Test Condition	GSM 850 EGPRS		

### GSM 850 EGPRS - Packet Switched (GSM Mode CH 128)

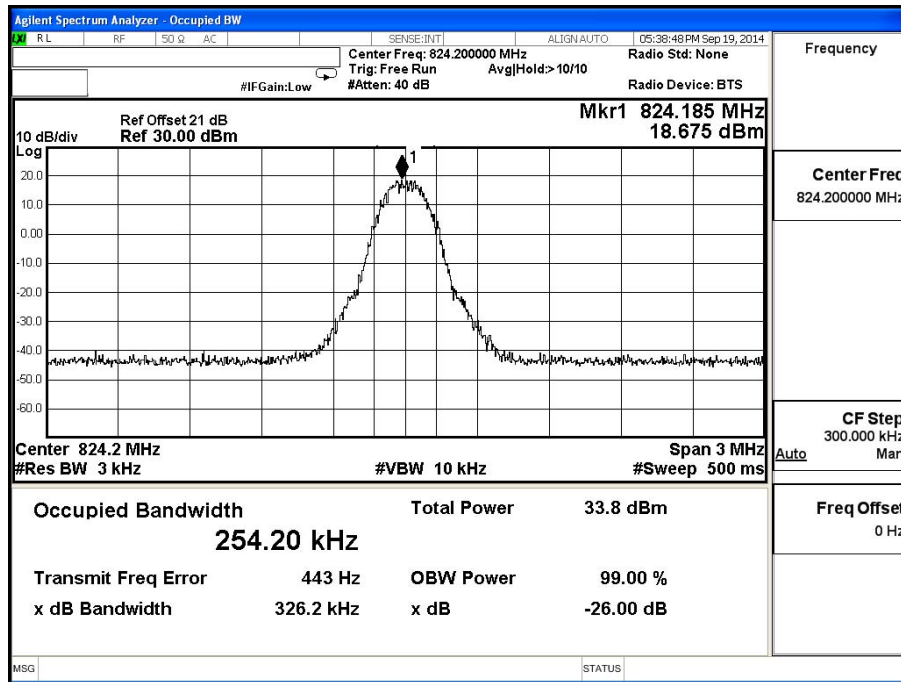

### GSM 850 EGPRS - Packet Switched (GSM Mode CH189)

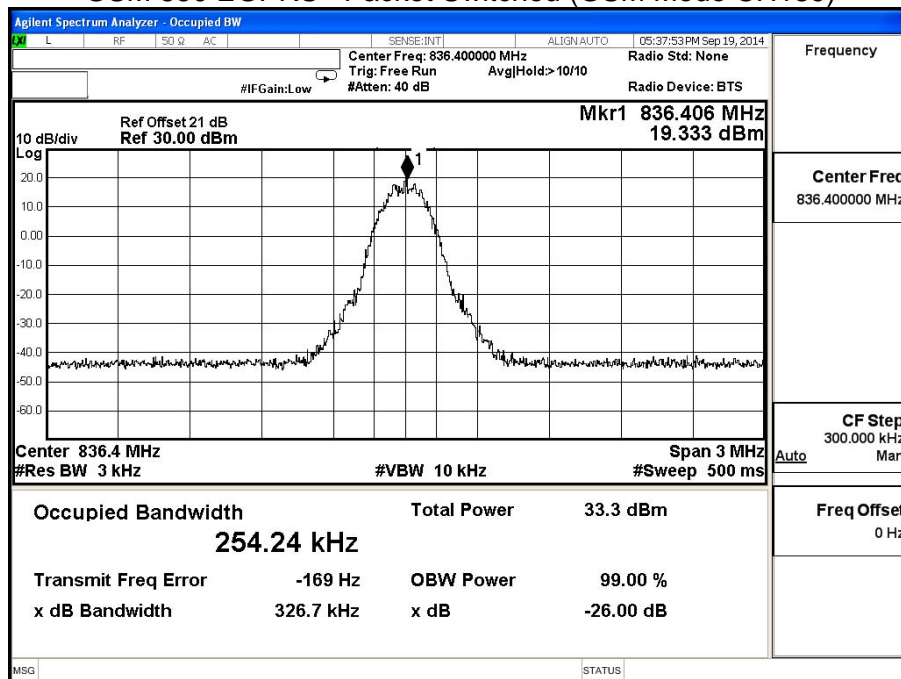

Product	Intel 7260M2NA		
Test Mode	Occupied Bandwidth		
Date of Test	2014/09/10	Test Site	CTR
Test Condition	GSM 850 EGPRS		

GSM 850 EGPRS - Packet Switched (GSM Mode CH 251)

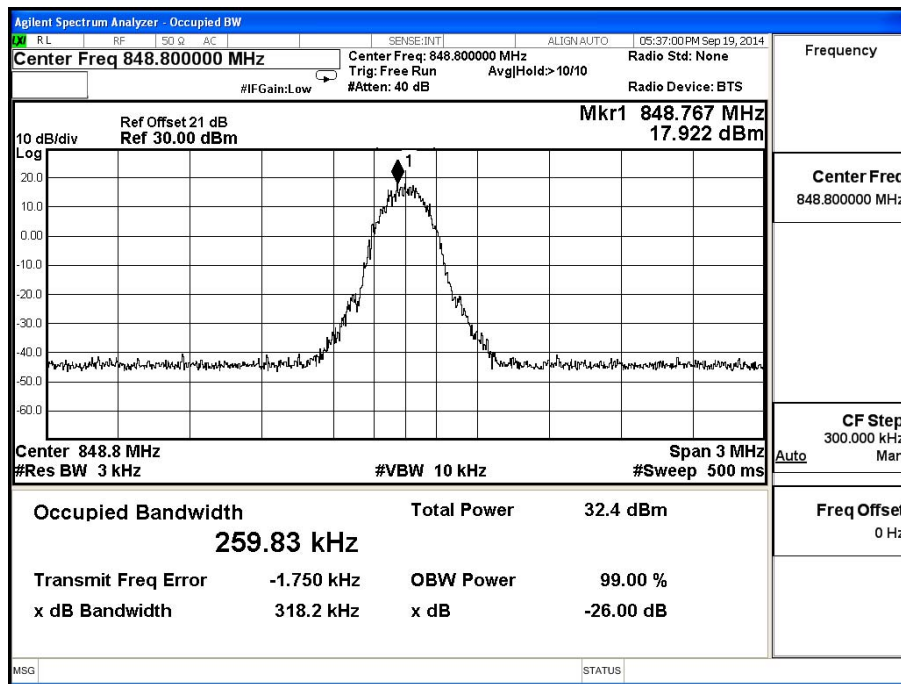

Product	Intel 7260M2NA		
Test Mode	Occupied Bandwidth		
Date of Test	2014/09/10	Test Site	CTR
Test Condition	PCS1900 GPRS		

### PCS1900 GPRS - Packet Switched (PCS Mode CH 512)

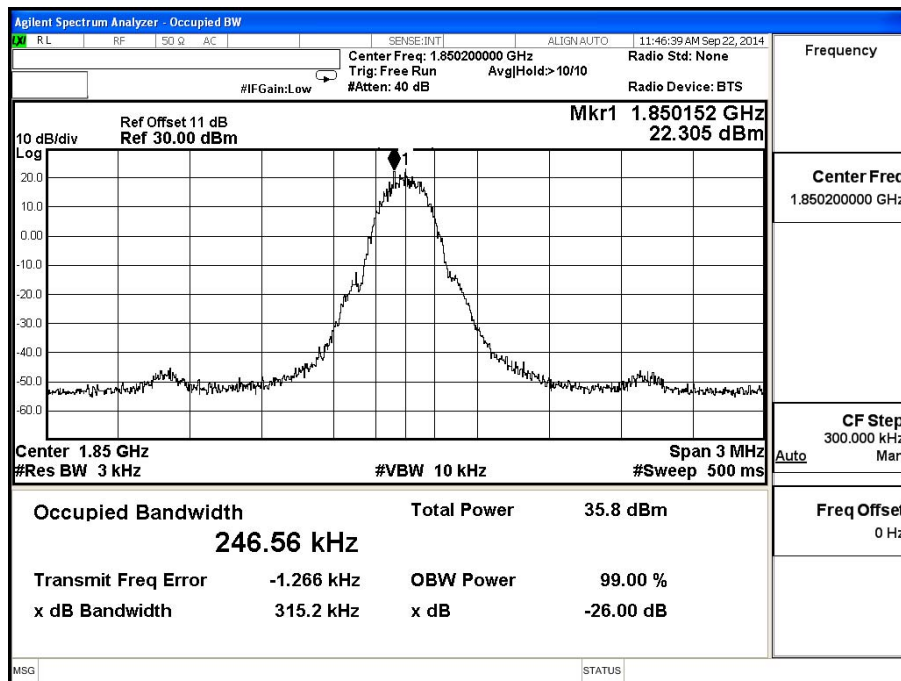

### PCS1900 GPRS - Packet Switched (PCS Mode CH661)

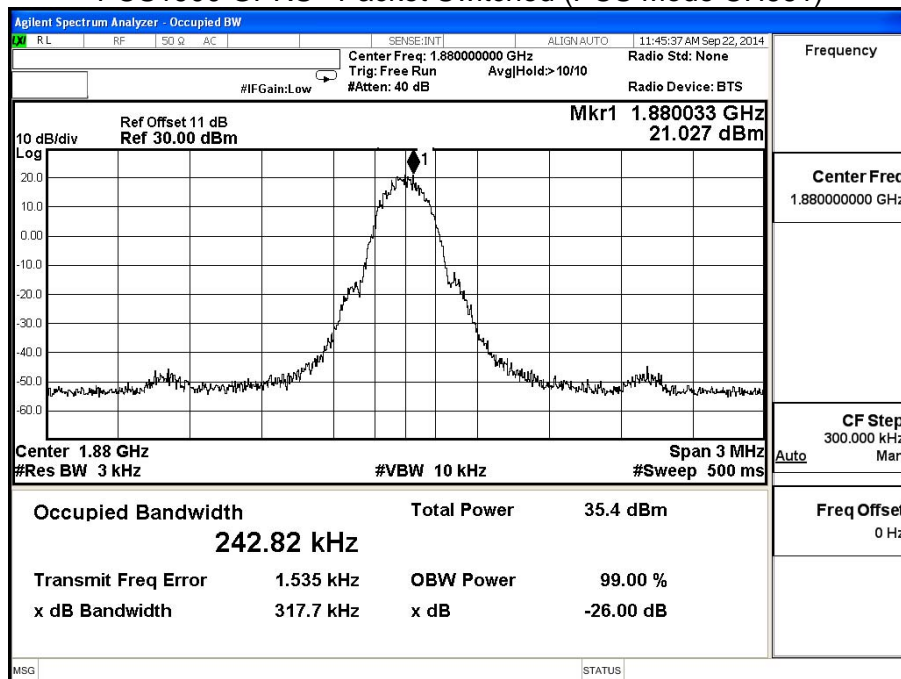

Product	Intel 7260M2NA		
Test Mode	Occupied Bandwidth		
Date of Test	2014/09/10	Test Site	CTR
Test Condition	PCS1900 GPRS		

PCS1900 GPRS - Packet Switched (PCS Mode CH 810)

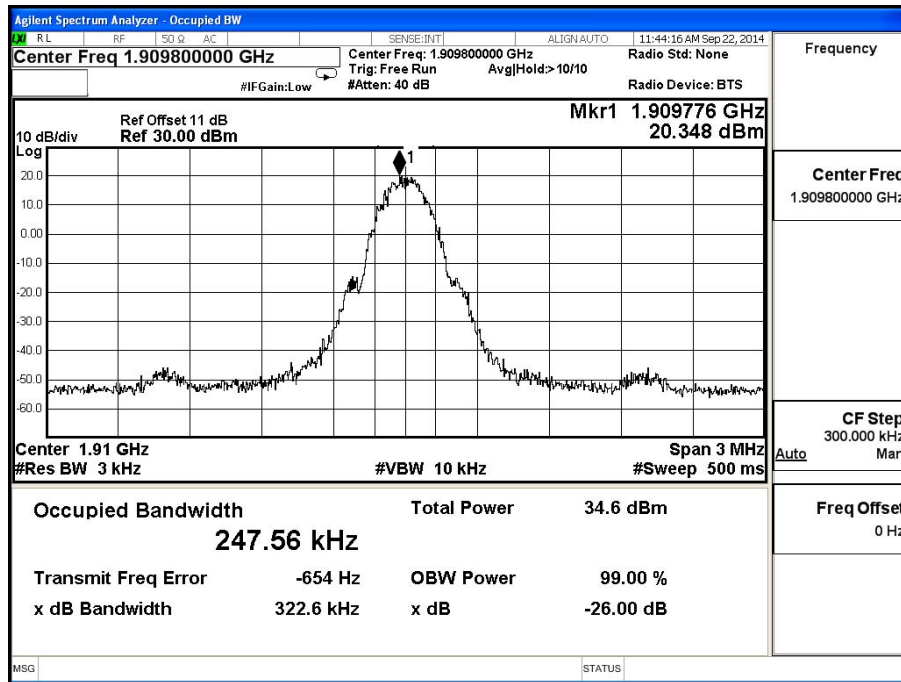

Product	Intel 7260M2NA		
Test Mode	Occupied Bandwidth		
Date of Test	2014/09/10	Test Site	CTR
Test Condition	PCS1900 EGPRS		

### PCS1900 EGPRS - Packet Switched (PCS Mode CH 512)

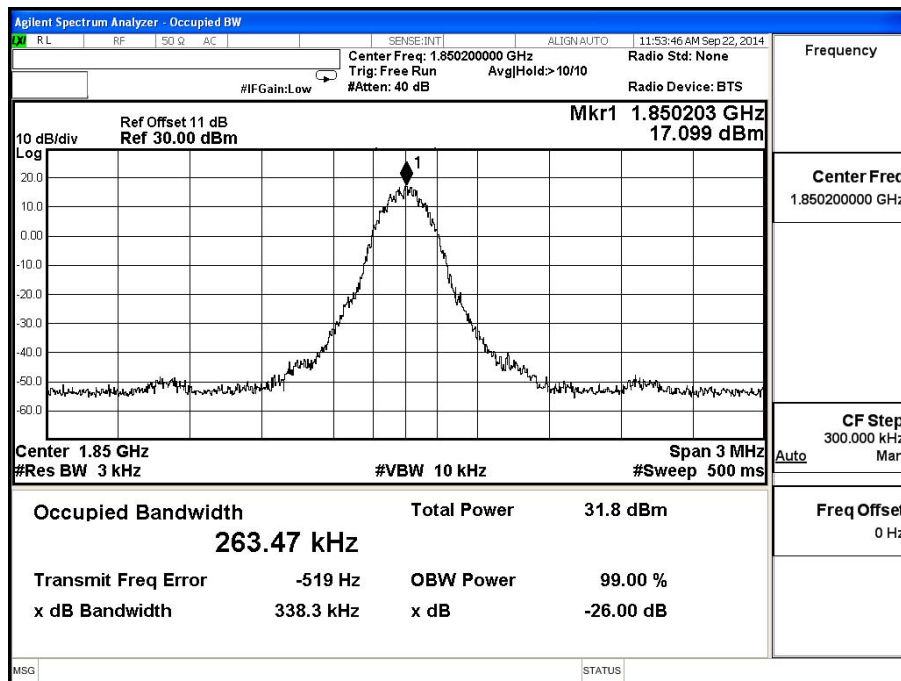

### PCS1900 EGPRS - Packet Switched (PCS Mode CH661)

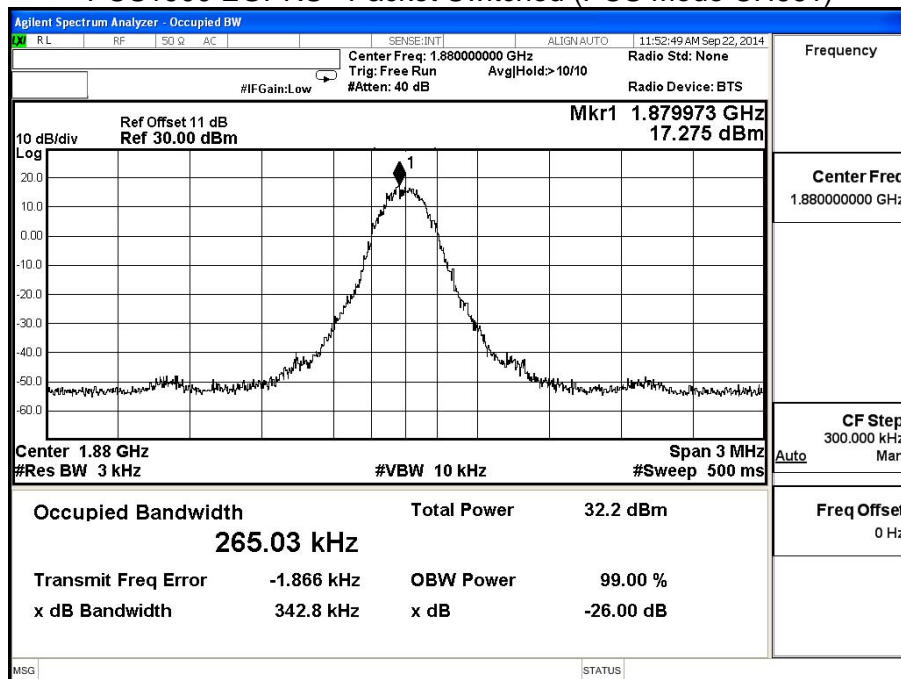

Product	Intel 7260M2NA		
Test Mode	Occupied Bandwidth		
Date of Test	2014/09/10	Test Site	CTR
Test Condition	PCS1900 EGPRS		

PCS1900 EGPRS - Packet Switched (PCS Mode CH 810)

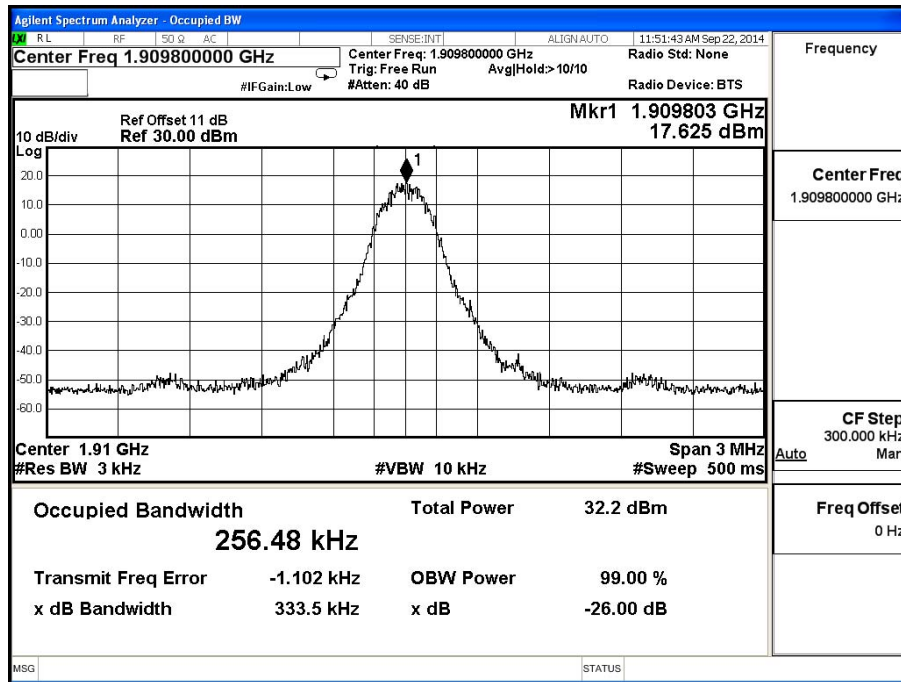

Product	Intel 7260M2NA		
Test Mode	Occupied Bandwidth		
Date of Test	2014/09/10	Test Site	CTR
Test Condition	WCDMA BAND 2		

### WCDMA BAND 2 (CH 9262)

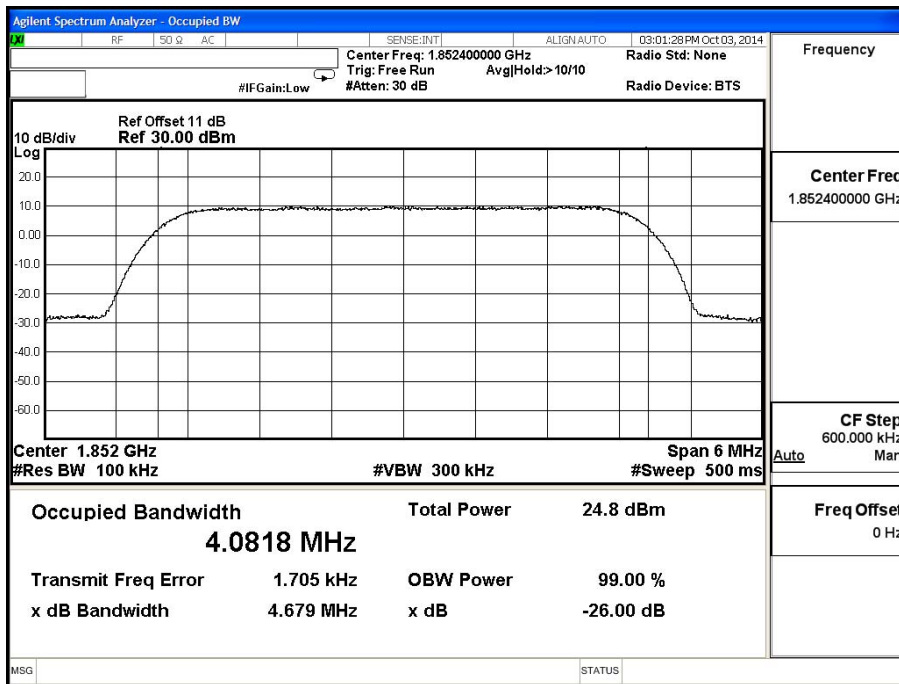

### WCDMA BAND 2 (CH 9400)

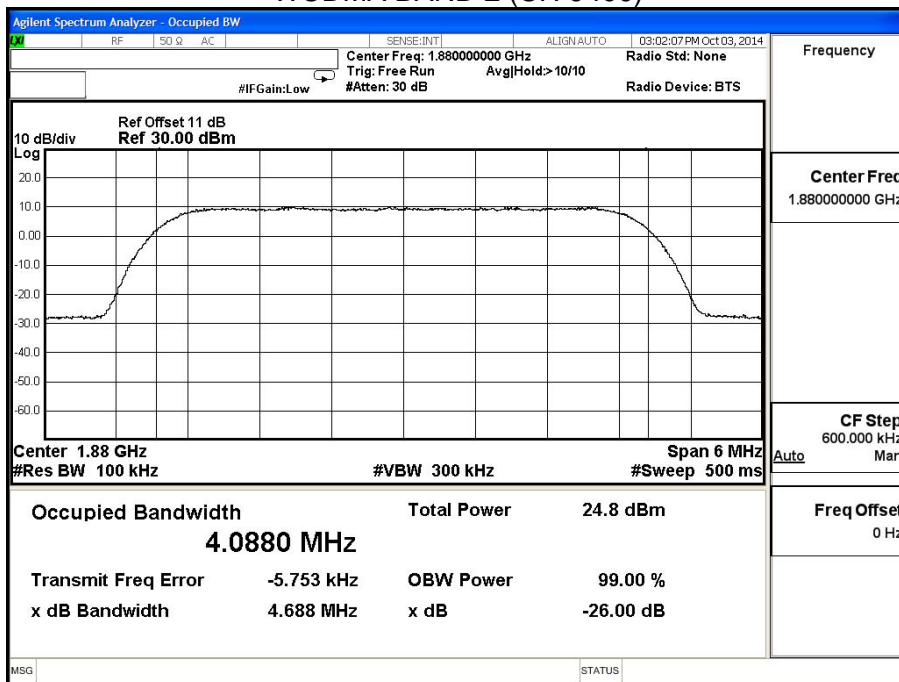

Product	Intel 7260M2NA		
Test Mode	Occupied Bandwidth		
Date of Test	2014/09/10	Test Site	CTR
Test Condition	WCDMA BAND 2		

### WCDMA BAND 2 (CH 9538)

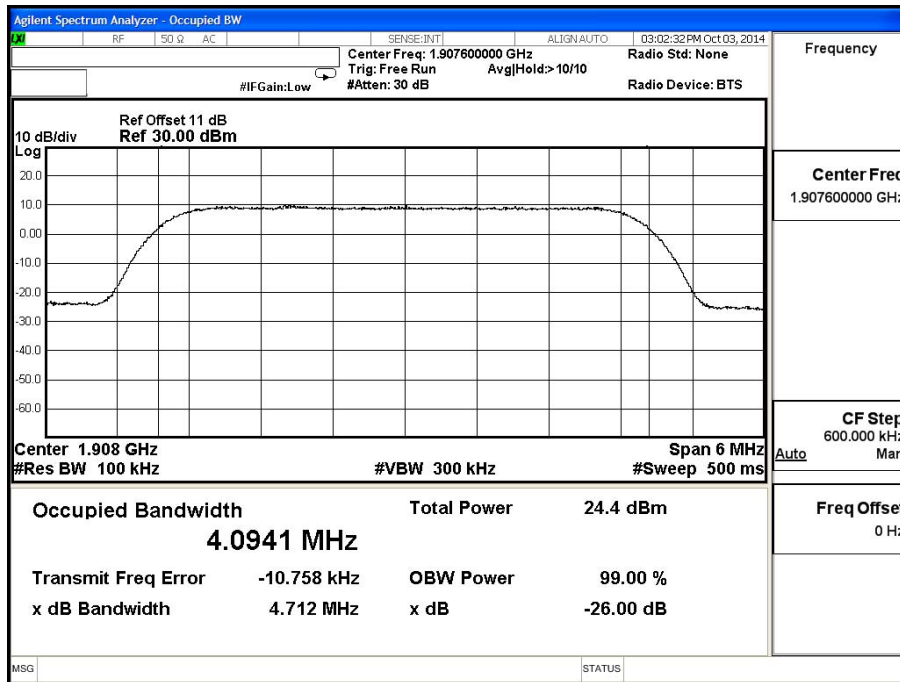



Product	Intel 7260M2NA		
Test Mode	Occupied Bandwidth		
Date of Test	2014/09/10	Test Site	CTR
Test Condition	WCDMA BAND 4		

### WCDMA BAND 4 (CH 1312)

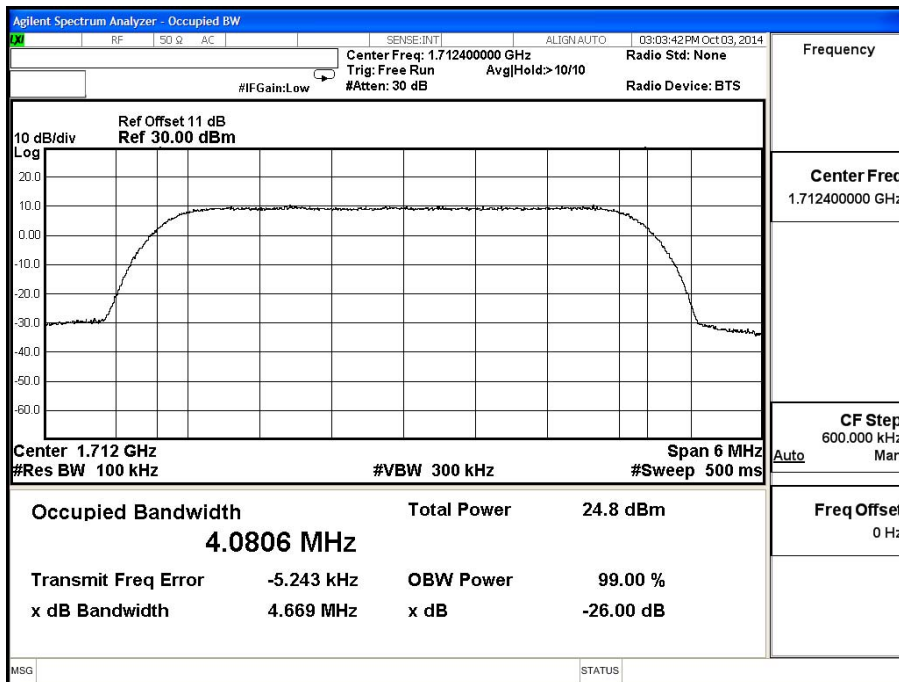

### WCDMA BAND 4 (CH 1413)

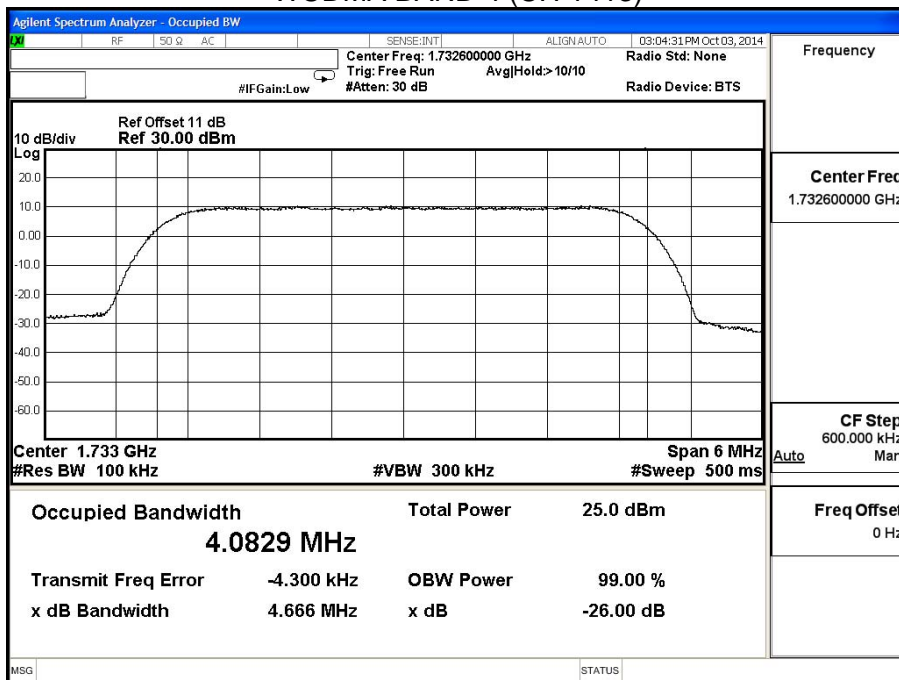

Product	Intel 7260M2NA		
Test Mode	Occupied Bandwidth		
Date of Test	2014/09/10	Test Site	CTR
Test Condition	WCDMA BAND 4		

WCDMA BAND 4 (CH 1513)

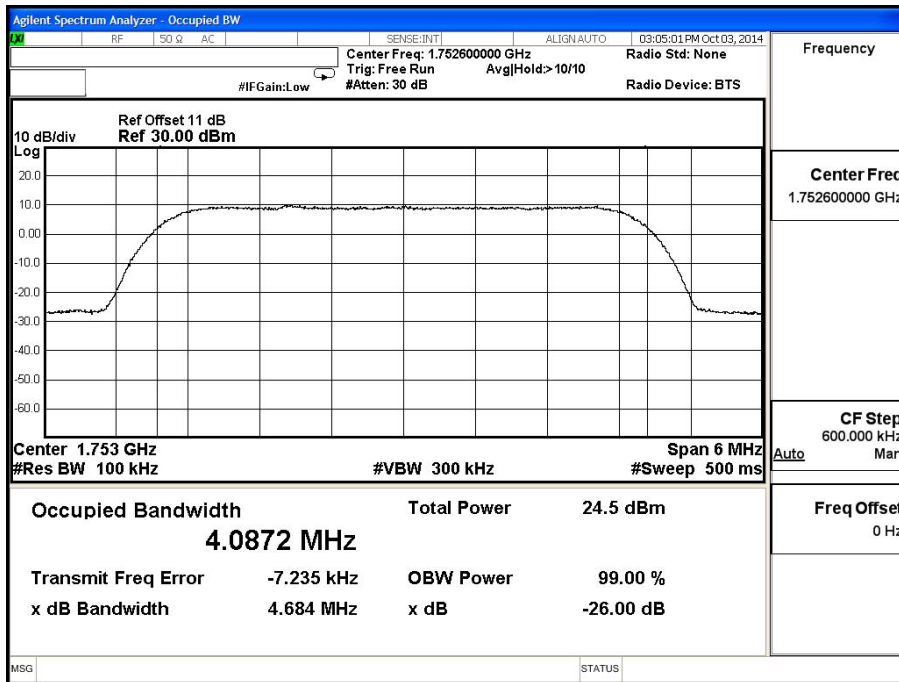

Product	Intel 7260M2NA		
Test Mode	Occupied Bandwidth		
Date of Test	2014/09/10	Test Site	CTR
Test Condition	WCDMA BAND 5		

### WCDMA BAND 5 (CH 4132)

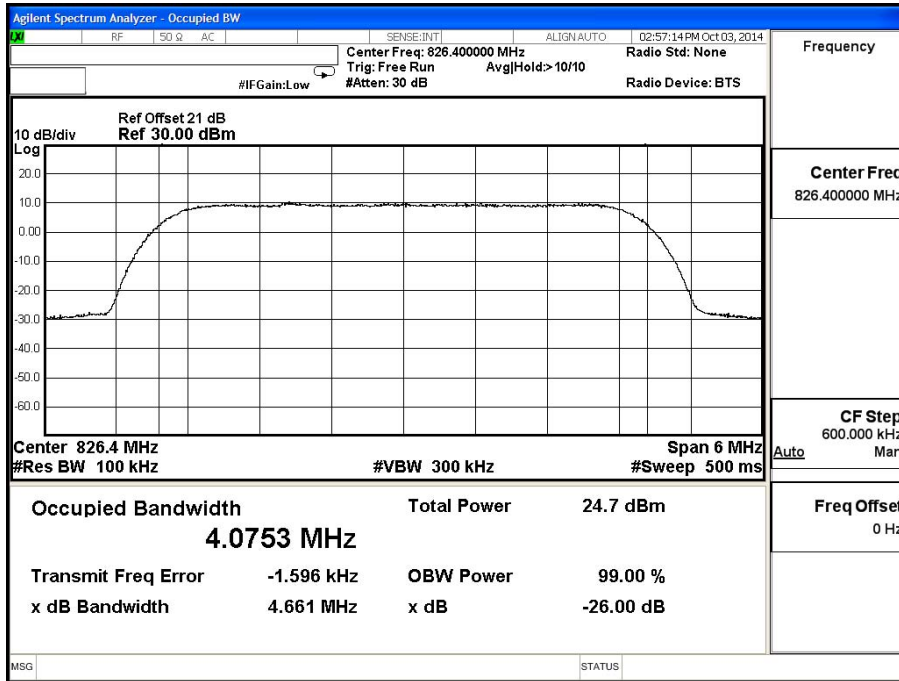

### WCDMA BAND 5 (CH 4183)

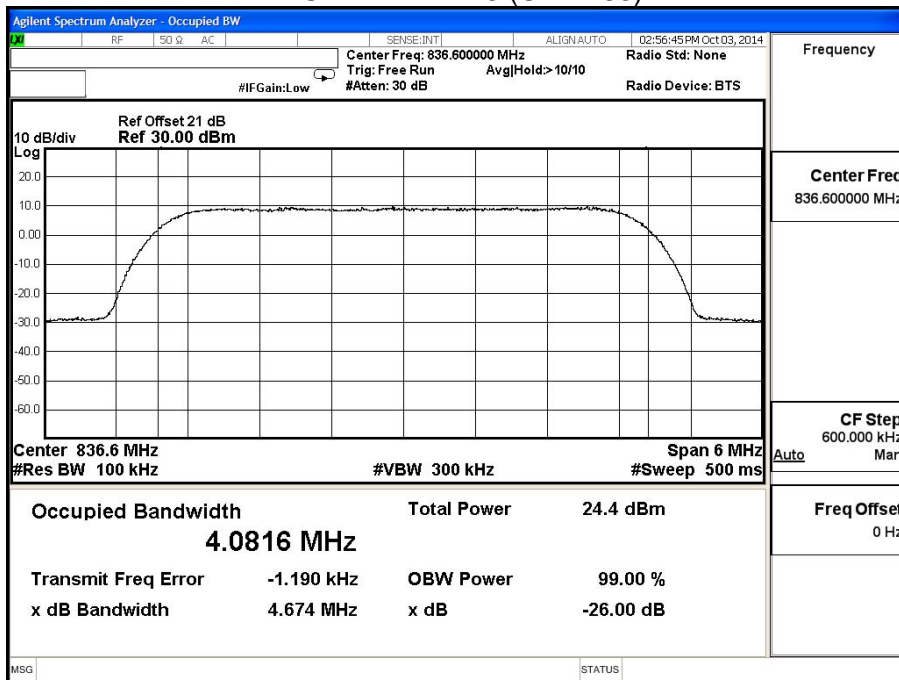

Product	Intel 7260M2NA		
Test Mode	Occupied Bandwidth		
Date of Test	2014/09/10	Test Site	CTR
Test Condition	WCDMA BAND 5		

WCDMA BAND 5 (CH 4233)

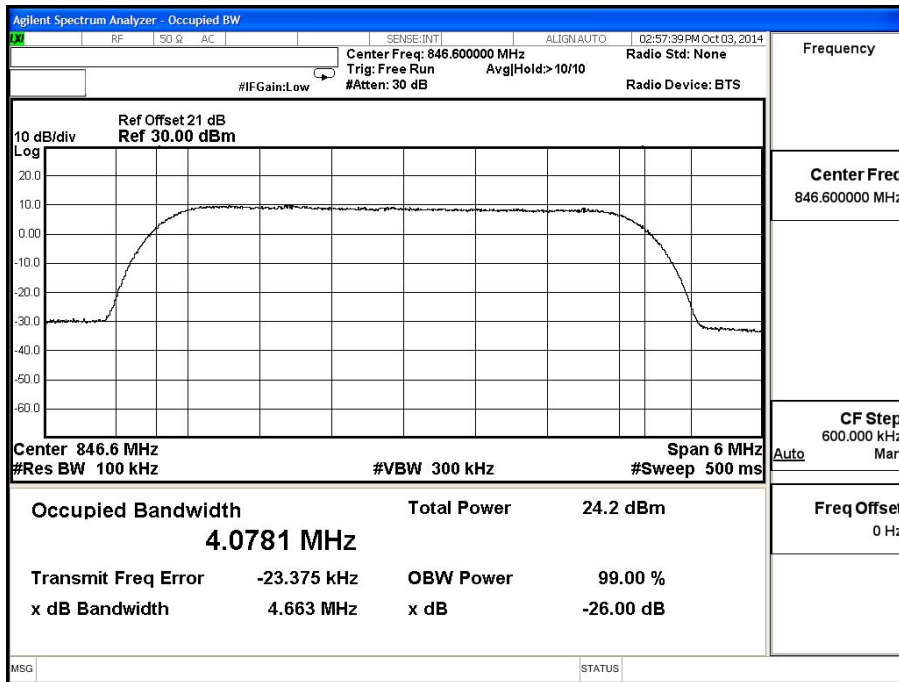

**5. Spurious Emission At Antenna Terminals (+/-1MHz)**

**5.1. Test Specification**

According to Part 2.1049, 22.917,24.238.27.53

**5.2. Setup**

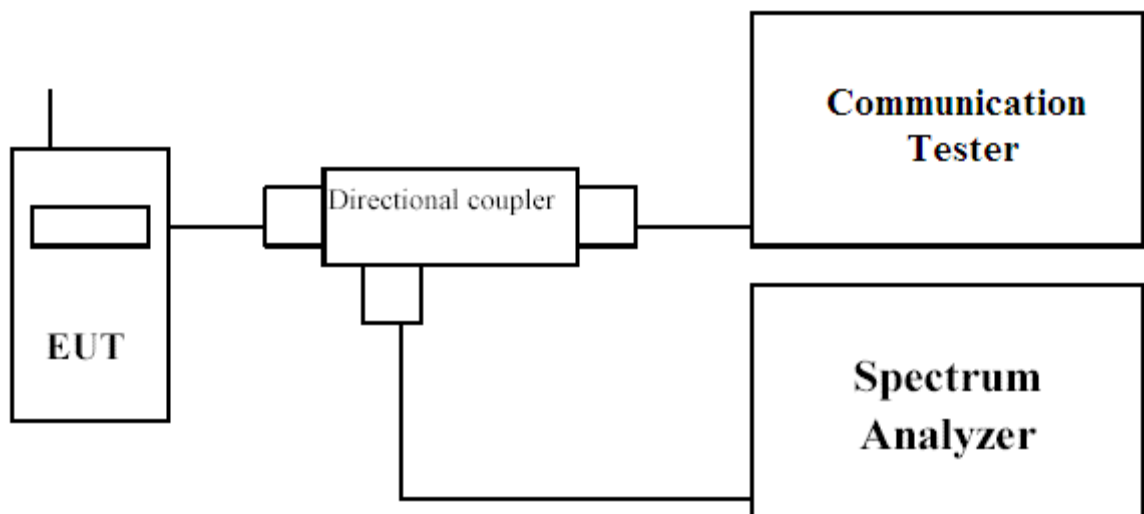

**5.3. Limits**

The power of any emission outside of the authorized operating frequency ranges must be attenuated below the transmitting power (P) by a factor of at least  $43 + 10 \log(P)$  dB.

**5.4. Test Procedure**

In accordance with Part 22.917, 24.238 & 27.53, at least 1% of the emission bandwidth was used for the resolution and video bandwidths up to 1MHz away from the Block Edge. At greater than 1MHz, the resolution and video bandwidth were set 3 x RBW.

The reference power and path losses of all channels used for testing in each frequency block were measured.

5.5. Test Result of Spurious Emission At Antenna Terminals (+/-1MHz)

Product	Intel 7260M2NA		
Test Mode	Spurious Emission At Antenna Terminals (+/-1MHz)		
Date of Test	2014/09/20	Test Site	CTR
Test Condition	Block Edge Test (GSM 850 GPRS)		

GSM 850 GPRS Lower Channel 128 (824.2MHz)

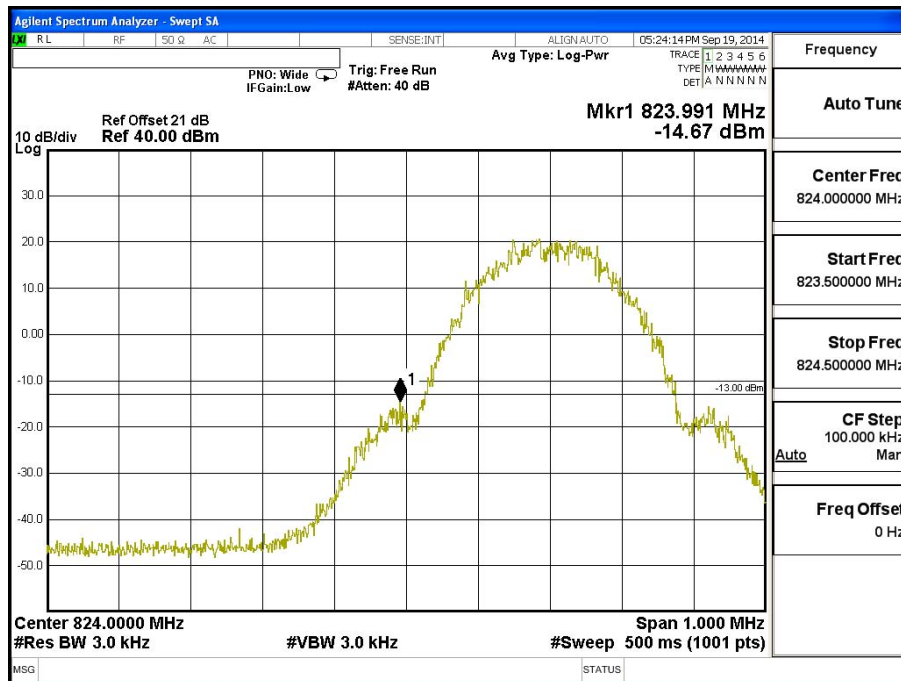

GSM 850 GPRS Upper Channel 251 (848.8MHz)

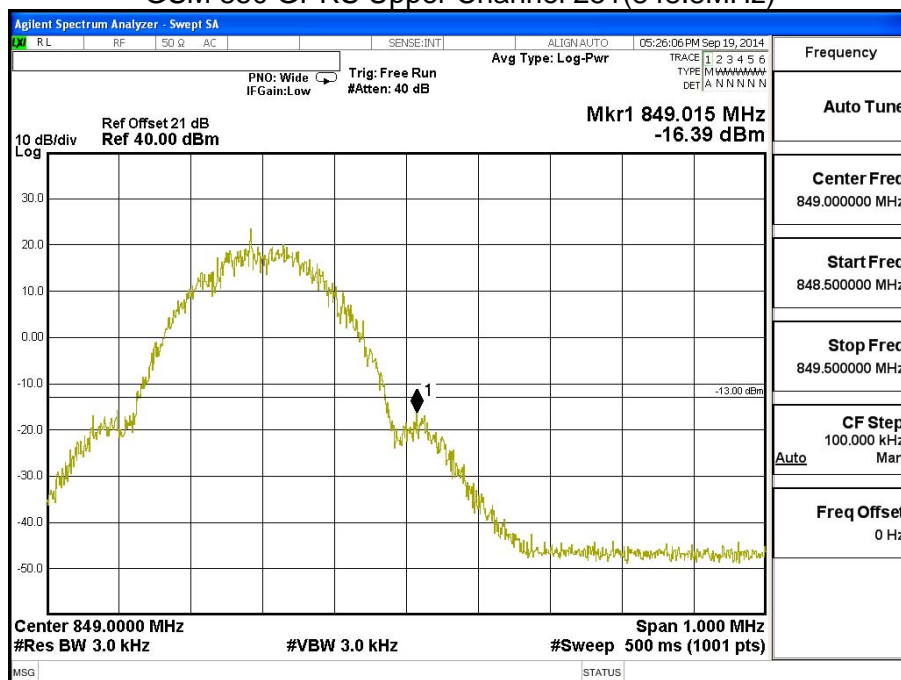

Product	Intel 7260M2NA		
Test Mode	Spurious Emission At Antenna Terminals (+/-1MHz)		
Date of Test	2014/09/20	Test Site	CTR
Test Condition	Block Edge Test (GSM 850 EGPRS)		

### GSM 850 EGPRS Lower Channel 128 (824.2MHz)

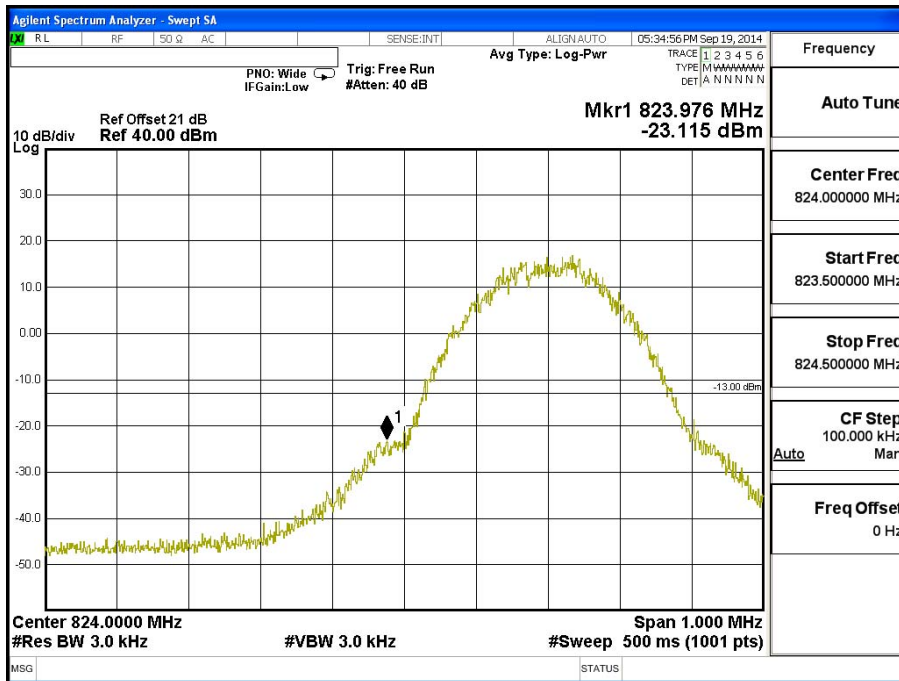

### GSM 850 EGPRS Upper Channel 251(848.8MHz)

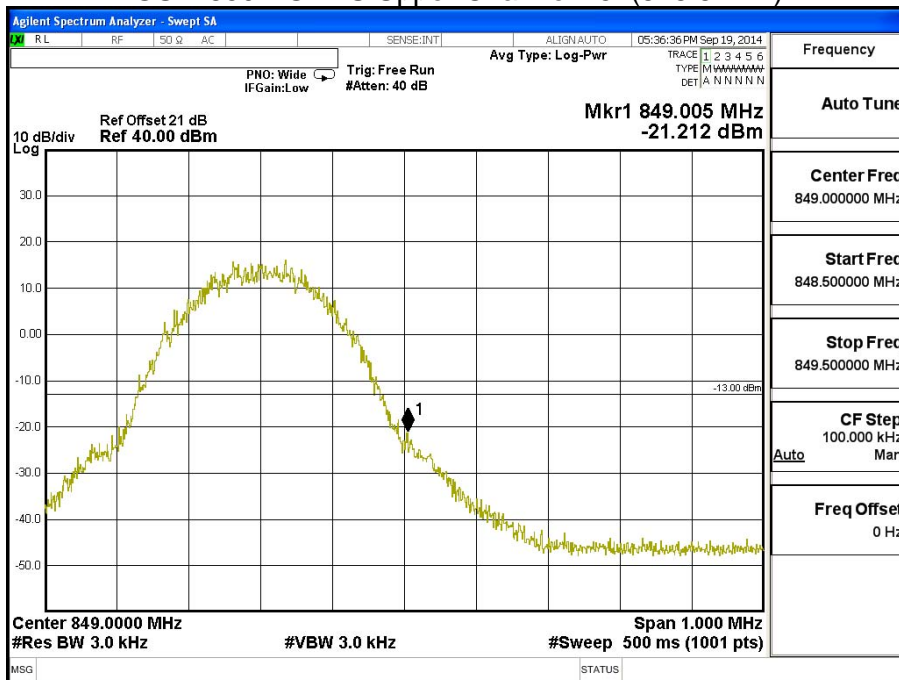

Product	Intel 7260M2NA		
Test Mode	Spurious Emission At Antenna Terminals (+/-1MHz)		
Date of Test	2014/09/20	Test Site	CTR
Test Condition	Block Edge Test (PCS 1900 GPRS)		

### PCS 1900 GPRS Lower Channel 512 (1850.2MHz)

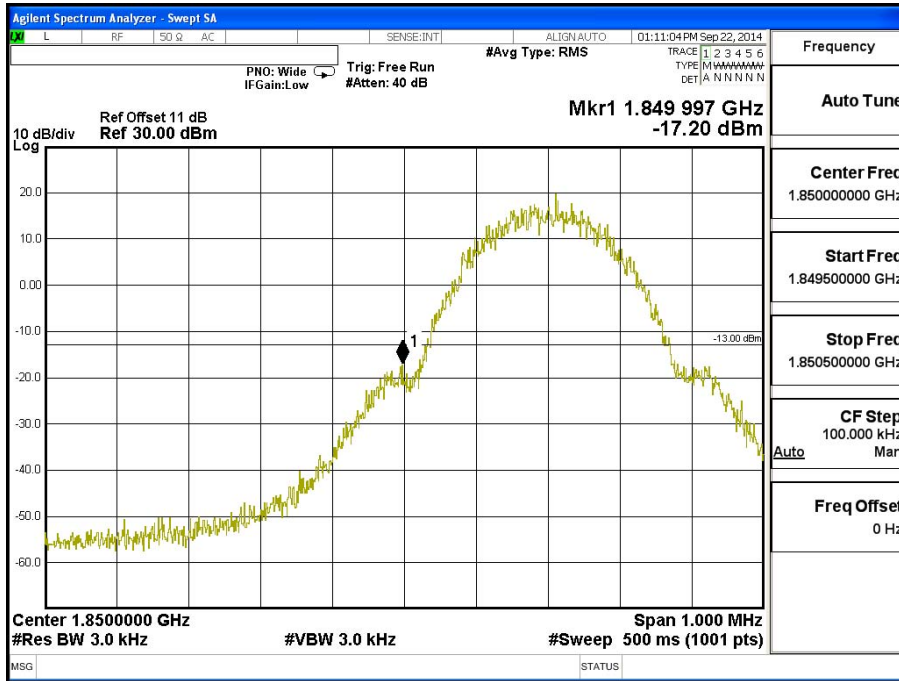

### PCS 1900 GPRS Upper Channel 810(1910.0MHz)

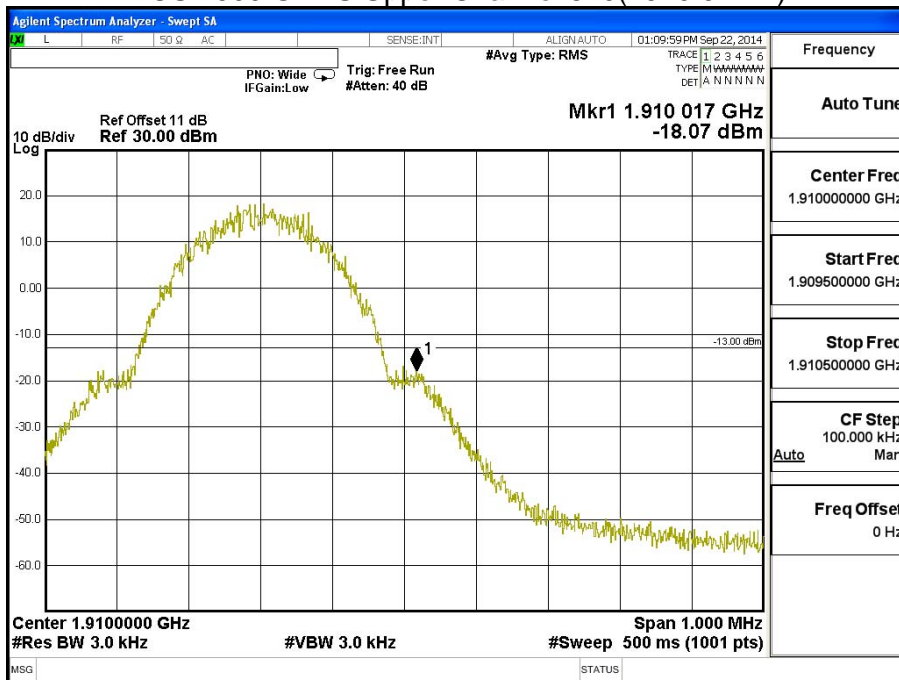



Product	Intel 7260M2NA		
Test Mode	Spurious Emission At Antenna Terminals (+/-1MHz)		
Date of Test	2014/09/20	Test Site	CTR
Test Condition	Block Edge Test (PCS 1900 EGPRS)		

### PCS 1900 EGPRS Lower Channel 512 (1850.2MHz)

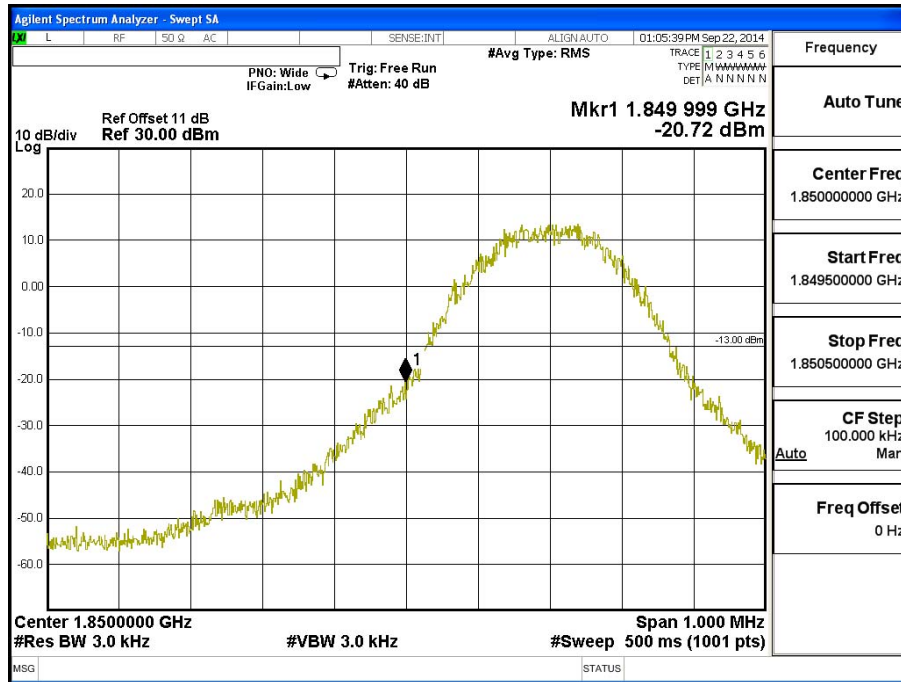

### PCS 1900 EGPRS Upper Channel 810(1910.0MHz)

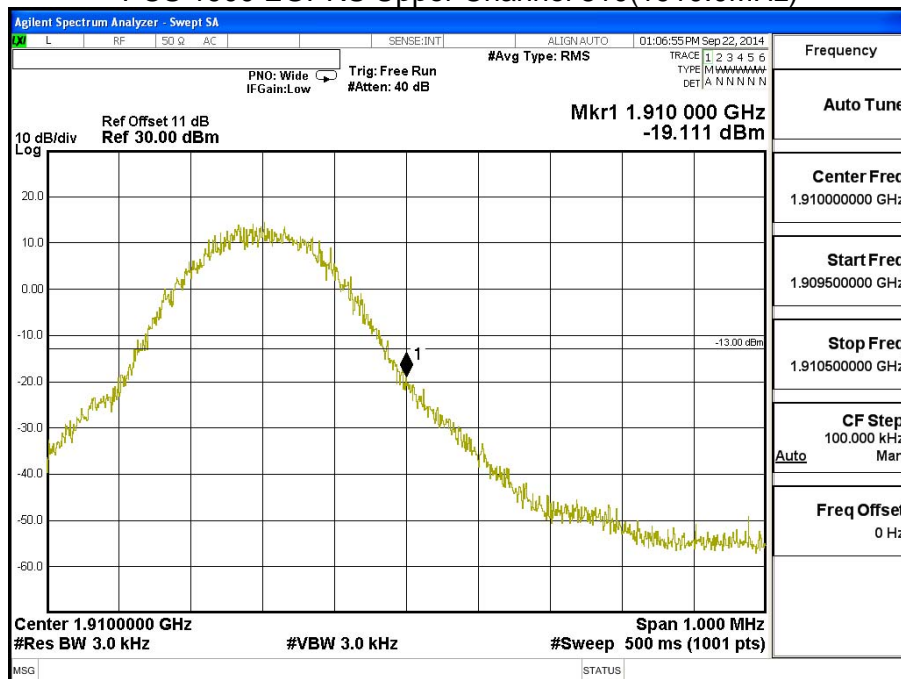

Product	Intel 7260M2NA		
Test Mode	Spurious Emission At Antenna Terminals (+/-1MHz)		
Date of Test	2014/10/03	Test Site	CTR
Test Condition	Block Edge Test (WCDMA BAND 2)		

### WCDMA BAND 2 Lower Channel 9262 (1852.4MHz)

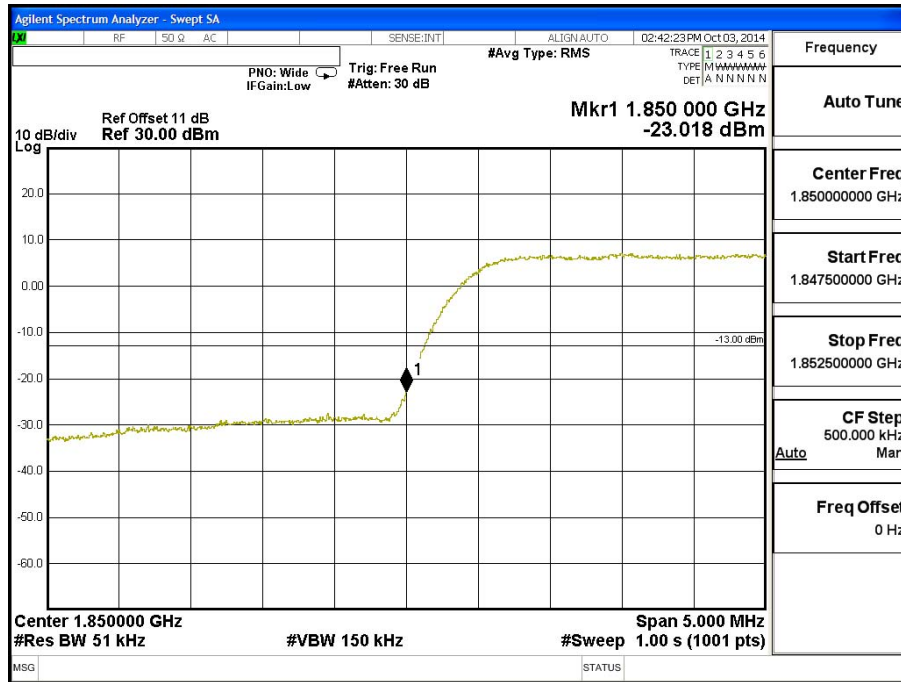

### WCDMA BAND 2 Upper Channel 9538 (1907.6 MHz)

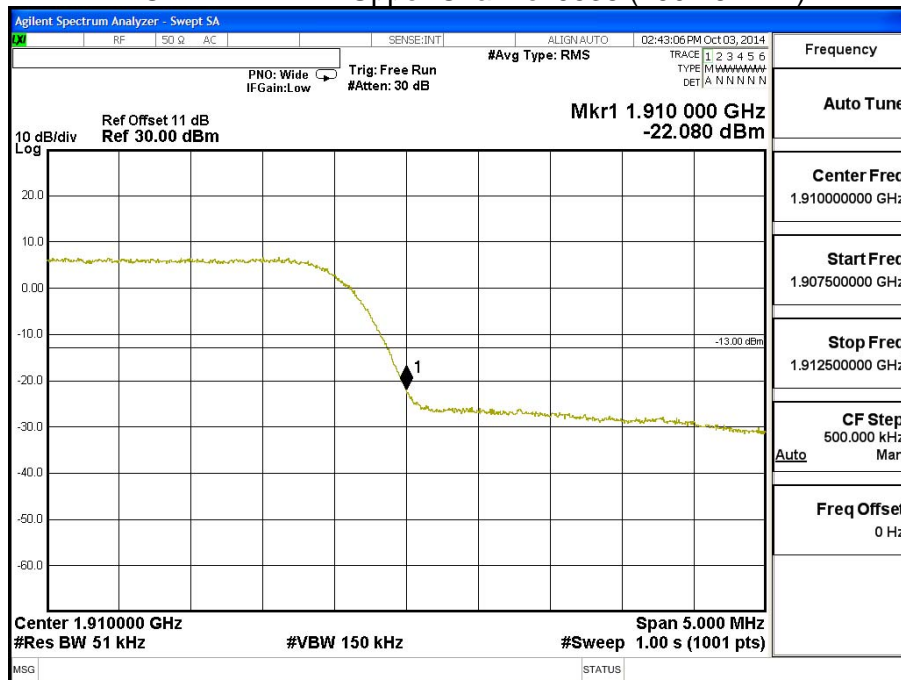

Product	Intel 7260M2NA		
Test Mode	Spurious Emission At Antenna Terminals (+/-1MHz)		
Date of Test	2014/10/03	Test Site	CTR
Test Condition	Block Edge Test (WCDMA BAND 4)		

### WCDMA BAND 4 Lower Channel 1312 (1712.4MHz)

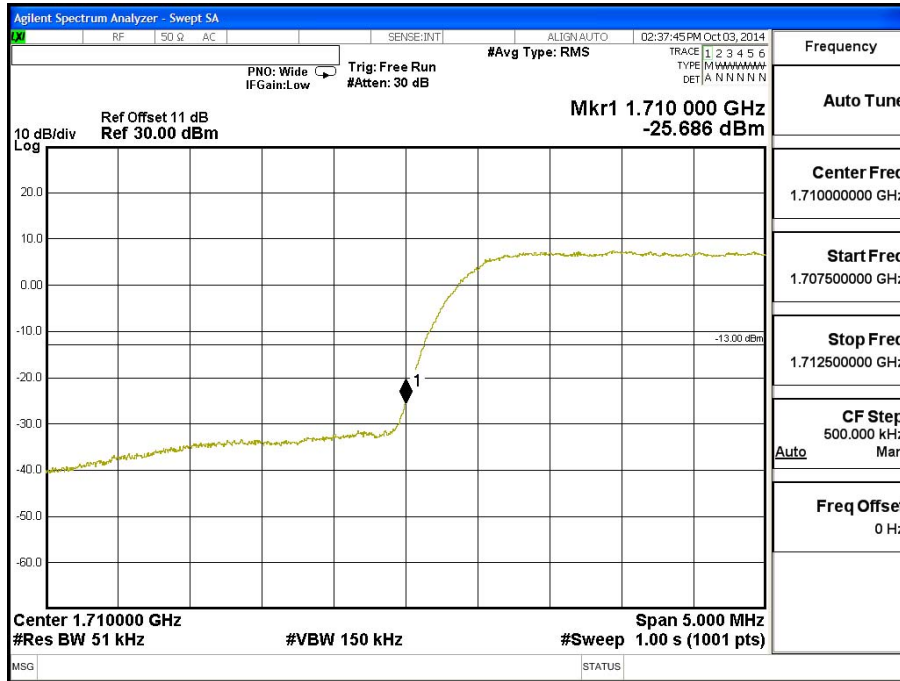

### WCDMA BAND 4 Upper Channel 1513 (1752.6MHz)

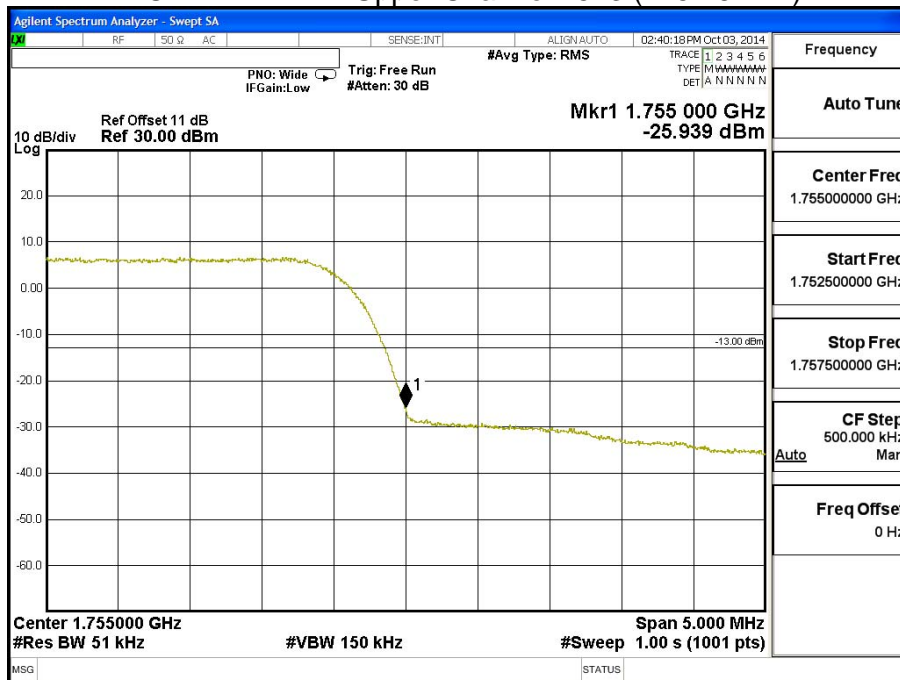

Product	Intel 7260M2NA		
Test Mode	Spurious Emission At Antenna Terminals (+/-1MHz)		
Date of Test	2014/10/03	Test Site	CTR
Test Condition	Block Edge Test (WCDMA BAND 5)		

### WCDMA BAND 5 Lower Channel 4132 (826.4MHz)

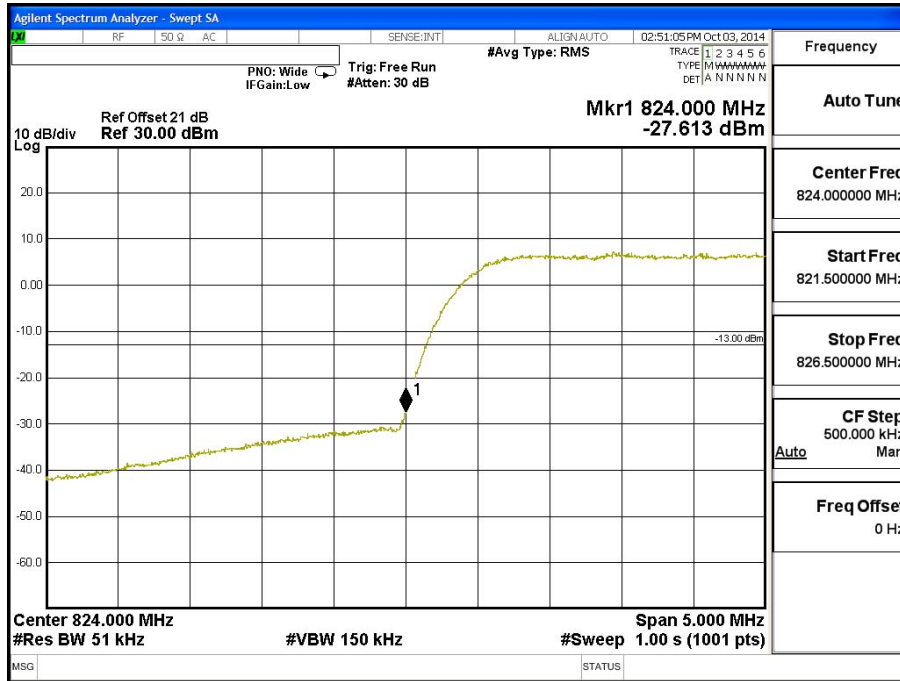

### WCDMA BAND 5 Upper Channel 4233 (846.6MHz)

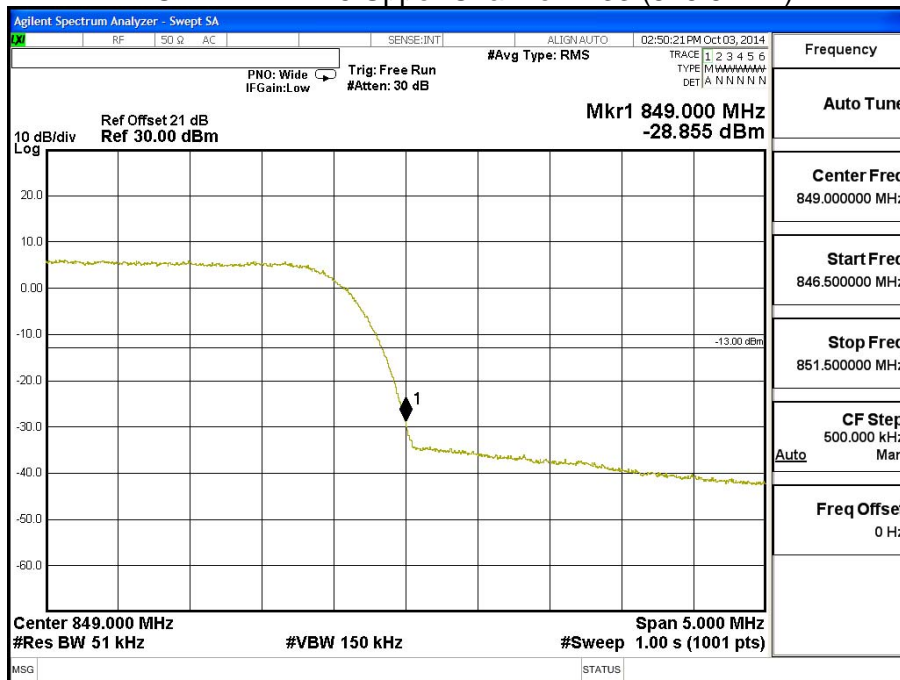

6. Spurious Emission

6.1. Test Specification

According to Part 2.1051, 2.1053, 22.917(a), 24.238(a).

6.2. Test Setup

6.1.1 Spurious emissions at antenna terminals.

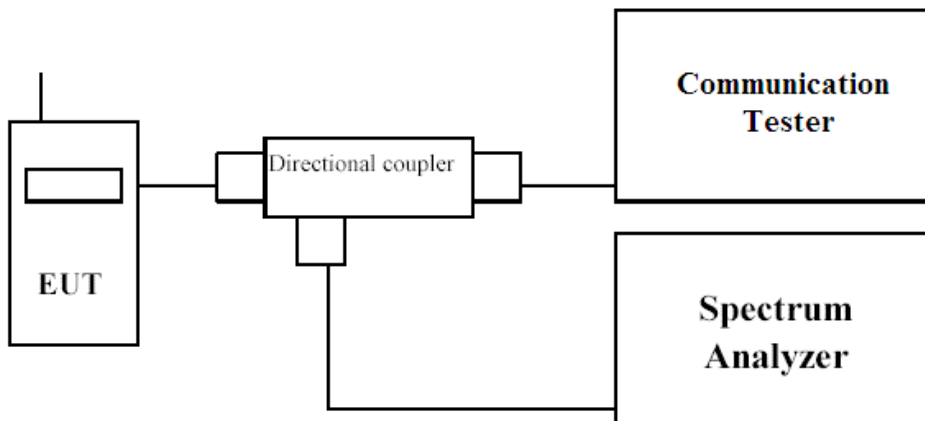

6.1.2 Field strength of spurious radiation.

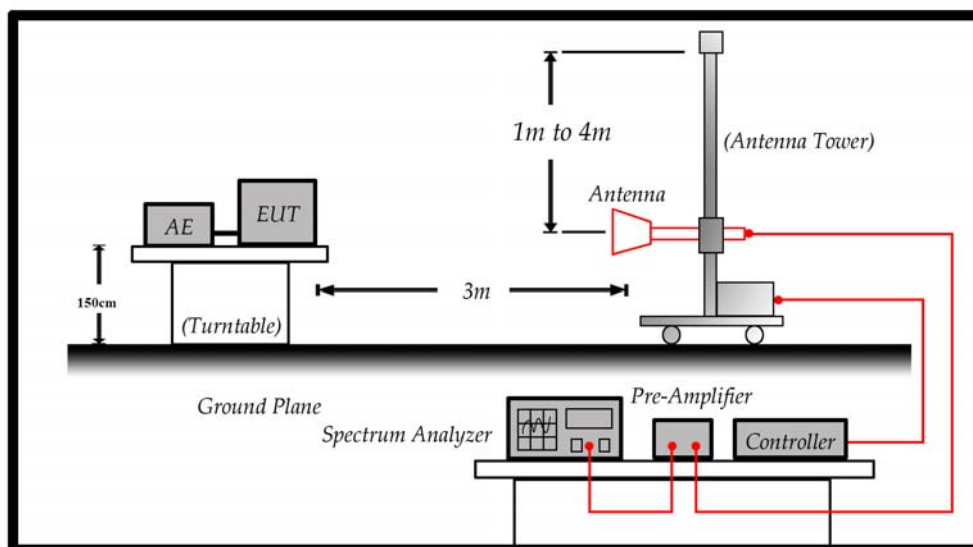

**6.3. Limits**

<b>Limit</b>	<b>&lt;-13dBm</b>
--------------	-------------------

43 + 10Log(P) down on the carrier where P is the power in Watts.

**6.4. Test Procedure**

In accordance with Part 2.1051/2.1053, the spurious emissions from the EUT were measured. The transmitter output power was attenuated using a combination of filters and attenuators and the frequency spectrum investigated from 30MHz to 20GHz. The EUT was set to transmit on full power. The resolution and video bandwidth was set to 1MHz and 3 x RBW. in accordance with Part 22.917 & 24.238 & 27.53. The spectrum analyzer detector was set to Max Hold. In addition, measurements were made up to the 10<sup>th</sup> harmonic of the fundamental. The device was then replaced with a substitution antenna, which input signal was adjusted until the received level matched that of the previously detected emission.

- (1) The EUT is tested with maximum rated TX power via the Base Station simulator.
- (2) The EUT is tested in three orthogonal planes, The worst case test configuration was found in the horizontal position.

The EUT is placed on a turn table which is 1.5 meter above ground. The turn table can rotate 360 degrees to determine the position of the maximum emission level. The EUT was positioned such that the distance from antenna to the EUT was 3 meters.

The antenna can move up and down between 1 meter and 4 meters to find out the maximum emission level.

Both horizontal and vertical polarization of the antenna are set on measurement. In order to find the maximum emission, all of the interface cables must be manipulated according to TIA/EIA 603-C on radiated measurement.

6.5. Test Result of Spurious Emission

Product	Intel 7260M2NA		
Test Mode	Spurious Emission (Conducted)		
Date of Test	2014/09/22	Test Site	CTR
Test Condition	GSM 850 GPRS	Test Range	30MHz~10GHz

GSM 850 GPRS High-Channel 251

Frequency (MHz)	Reading Level (dBm)	Path Loss (dB)	Emission Level (dBm)	Limit (dBm)
1697.6	-48.726	0.58	-48.146	-13
2546.4	-52.437	0.7	-51.737	-13
3395.2	-63.998	1.01	-62.988	-13
4244	-65.719	1.18	-64.539	-13
5092.8	-63.718	1.23	-62.488	-13
5941.6	-61.526	1.45	-60.076	-13
6790.4	-63.147	1.56	-61.587	-13
7639.2	-65.595	1.59	-64.005	-13
8488	-65.821	1.82	-64.001	-13

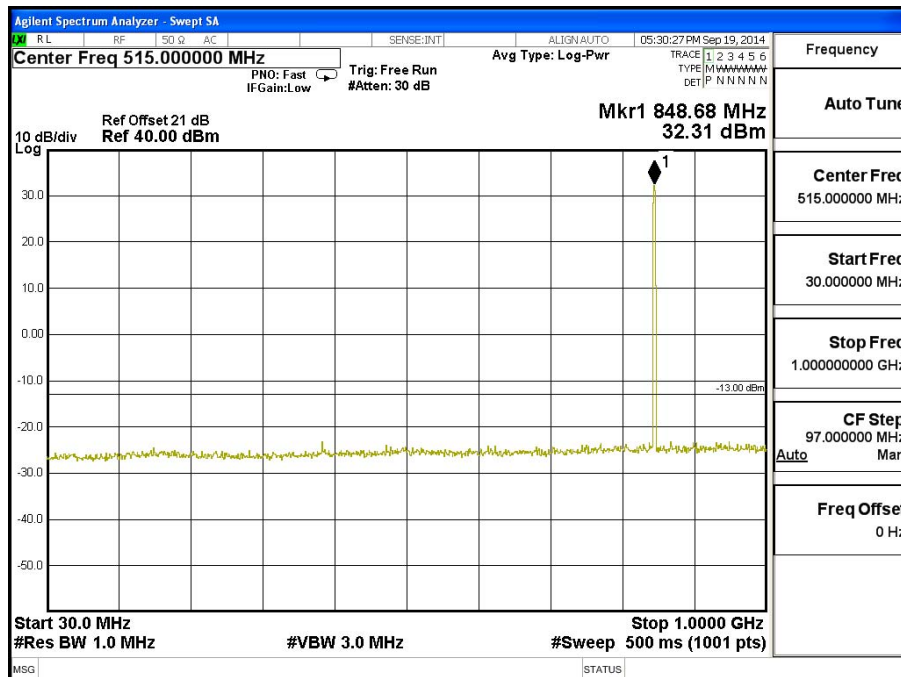

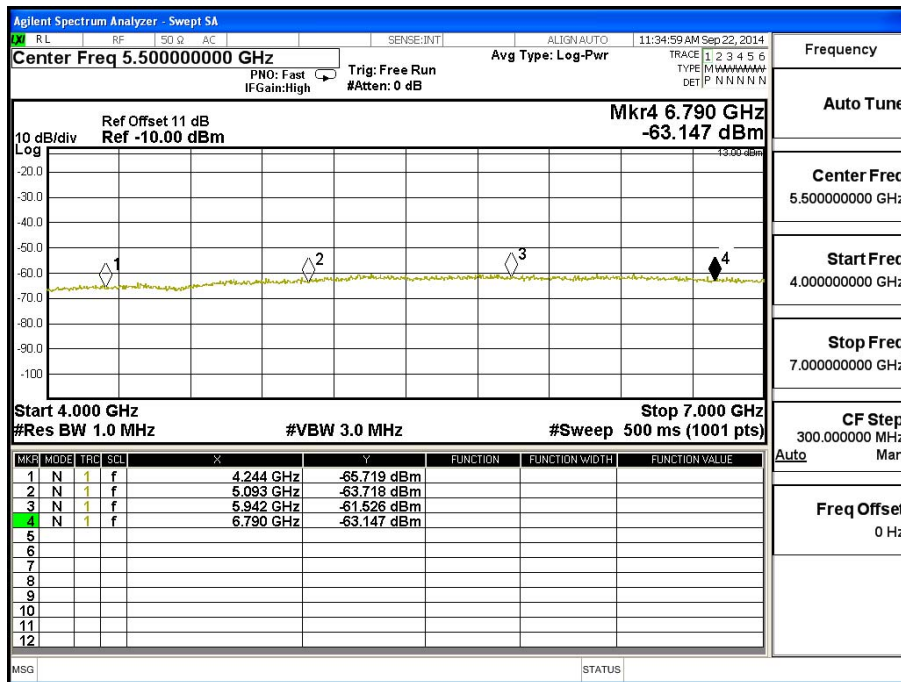
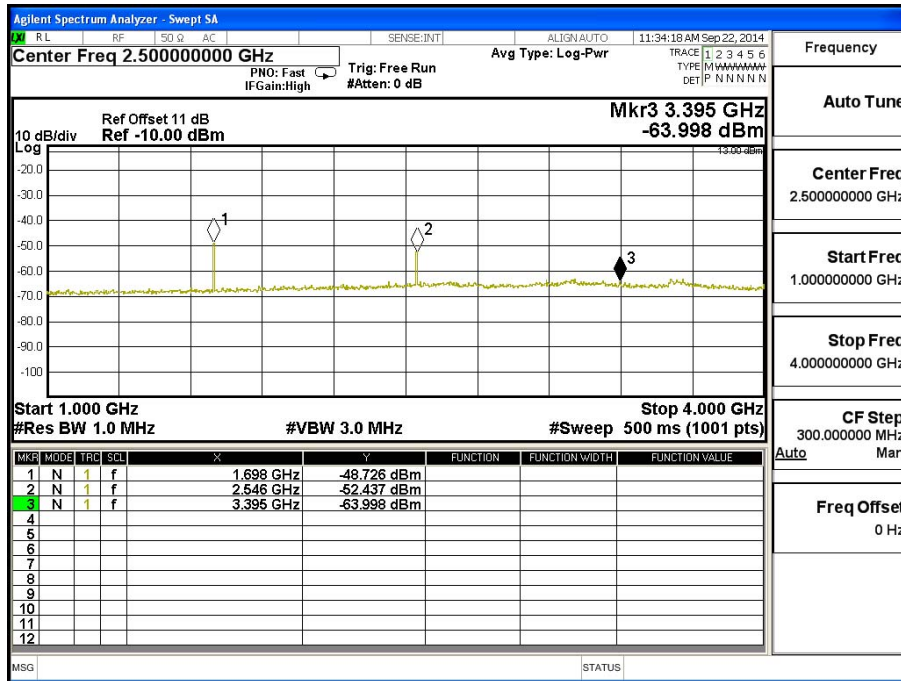



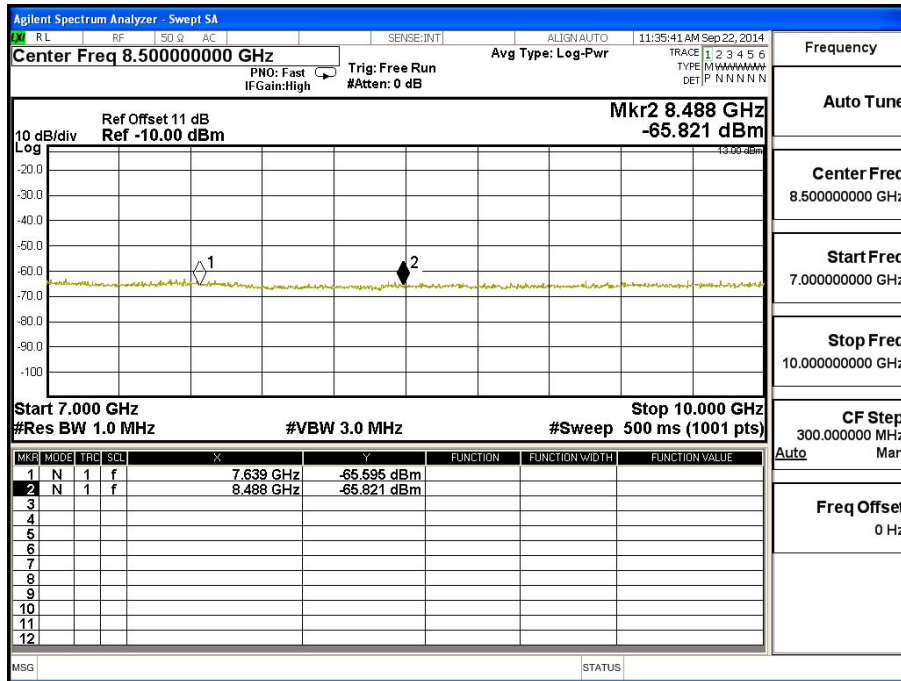

Product	Intel 7260M2NA		
Test Mode	Spurious Emission (Conducted)		
Date of Test	2014/09/22	Test Site	CTR
Test Condition	GSM 850 EGPRS	Test Range	30MHz~10GHz

### GSM 850 EGPRS Low-Channel 128

Frequency (MHz)	Reading Level (dBm)	Path Loss (dB)	Emission Level (dBm)	Limit (dBm)
1648.4	-51.547	0.58	-50.967	-13
2472.6	-50.068	0.7	-49.368	-13
3296.8	-63.535	1.01	-62.525	-13
4121	-66.140	1.18	-64.960	-13
4945.2	-63.624	1.23	-62.394	-13
5769.4	-60.663	1.45	-59.213	-13
6593.6	-62.535	1.56	-60.975	-13
7417.8	-64.856	1.59	-63.266	-13
8242	-65.712	1.82	-63.892	-13

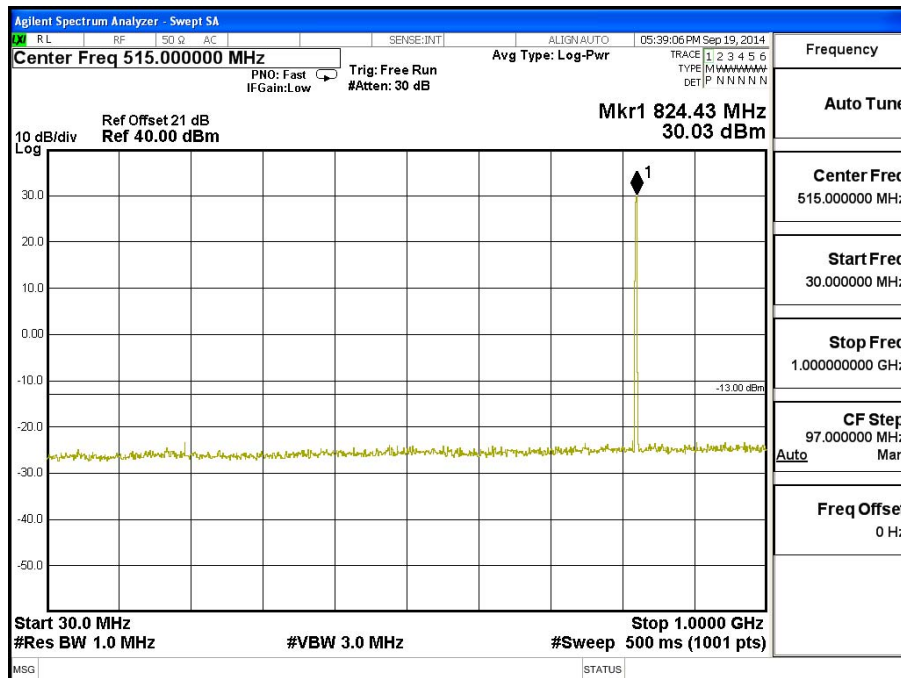

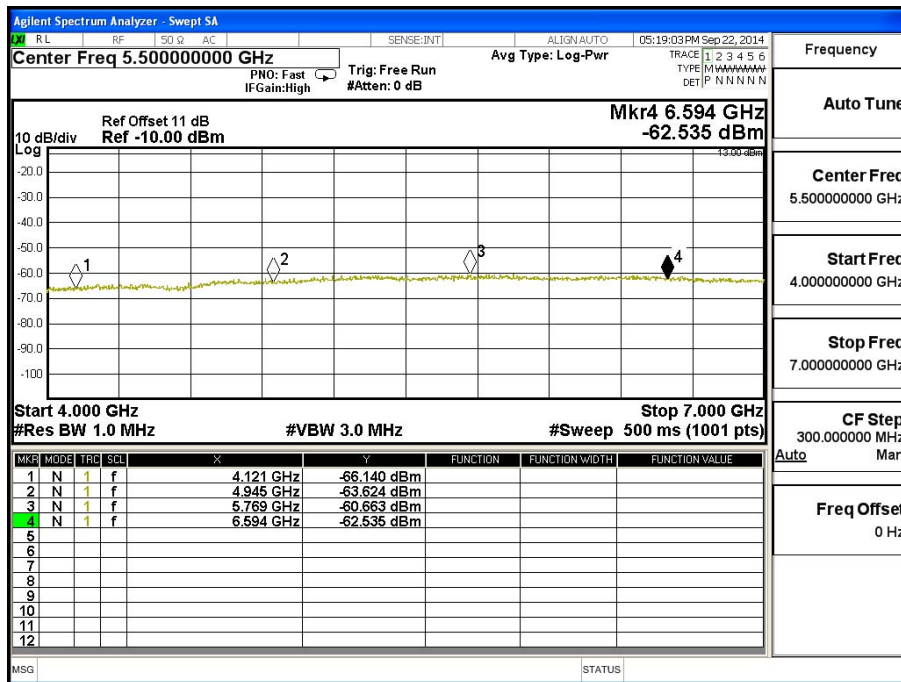
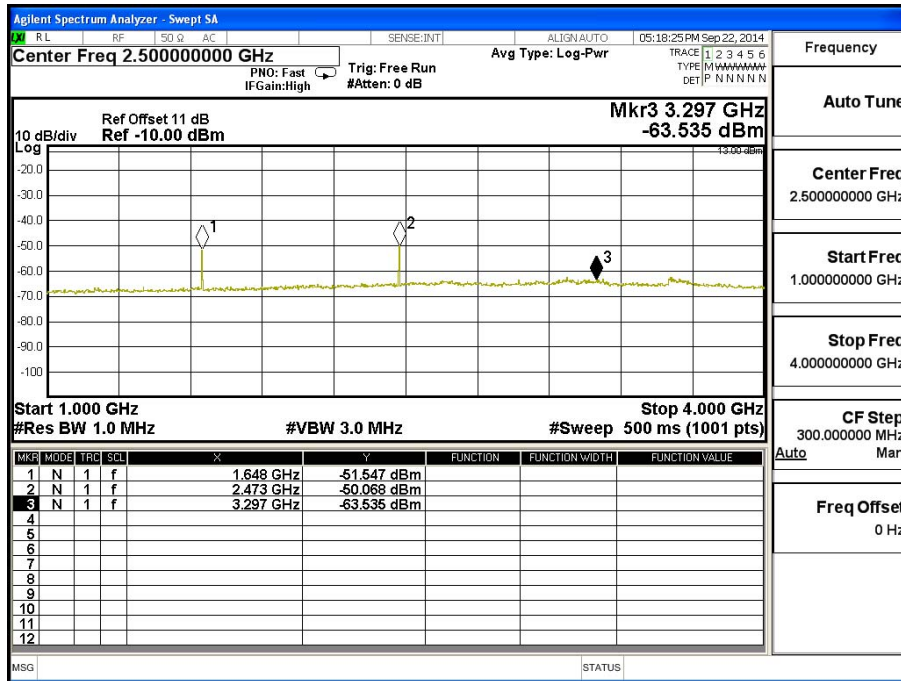

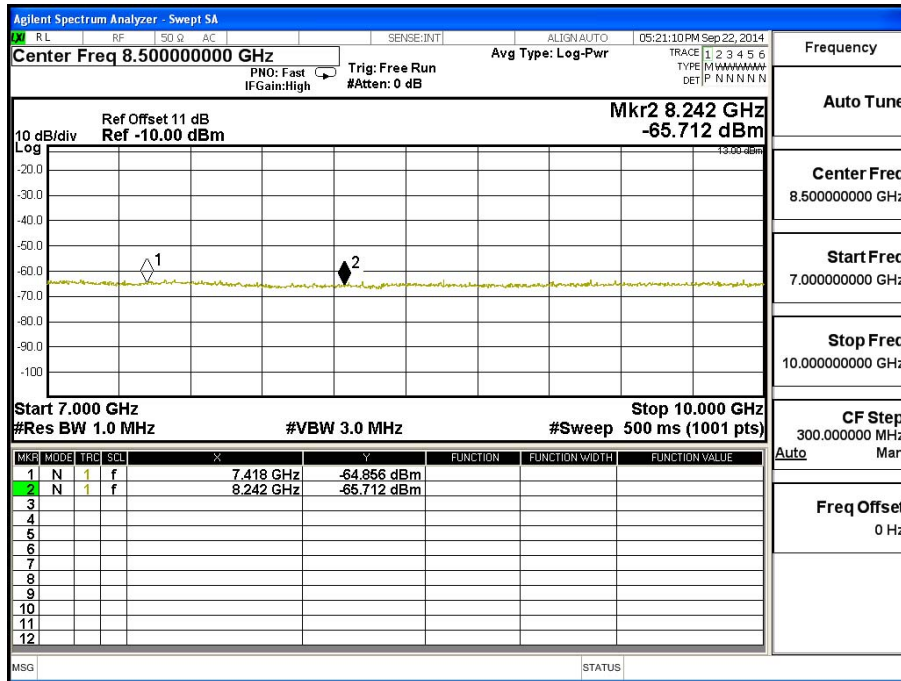

Product	Intel 7260M2NA		
Test Mode	Spurious Emission (Conducted)		
Date of Test	2014/09/22	Test Site	CTR
Test Condition	PCS 1900 GPRS	Test Range	30MHz~20GHz

### PCS 1900 GPRS Low-Channel 512

Frequency (MHz)	Reading Level (dBm)	Path Loss (dB)	Emission Level (dBm)	Limit (dBm)
3700.4	-44.370	1.1	-43.270	-13
5550.6	-61.761	1.23	-60.531	-13
7400.8	-65.210	1.59	-63.620	-13
9251	-65.488	1.89	-63.598	-13
11101.2	-57.324	2.07	-55.254	-13
12951.4	-64.450	2.26	-62.190	-13
14801.6	-60.257	2.64	-57.617	-13
16651.8	-59.902	3.5	-56.402	-13
18502	-58.781	3.7	-55.081	-13

