

TEST REPORT

R71319

**Covering the
DYNAMIC FREQUENCY SELECTION (DFS)
REQUIREMENTS
OF**

FCC Part 15 Subpart E (UNII)

**Intel Corporation
Model(s): 512AN_MMW**

COMPANY: Intel Corporation
2111 N.E. 25th Avenue
Hillsboro, OR 97124-5961

TEST SITE: Elliott Laboratories, Inc.
684 W. Maude Ave
Sunnyvale, CA 94085

REPORT DATE: April 9, 2008
REVISED: May 22, 2008

FINAL TEST DATE: April 9, 2008

TEST ENGINEER: Riaz Momand

AUTHORIZED SIGNATORY: _____

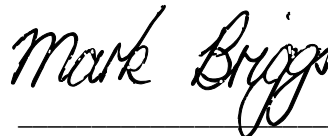

Mark Briggs
Staff engineer, EMC



2016-01

Elliott Laboratories, Inc. is accredited by the A2LA, certificate number 2016-01, to perform the test(s) listed in this report. This report shall not be reproduced, except in its entirety, without the written approval of Elliott Laboratories, Inc.

REVISION HISTORY

Rev #	Date	Comments	Modified By
1.0	4/25/08	First release	-
2.0	5/22/2008	Changed Intel contact to Robert Paxman in scope section. Corrected the description of product to check the selection for <i>Client Device (no In Service Monitoring, no Ad-Hoc mode)</i> . Previously the selection box for <i>Client Device with In-Service Monitoring</i> had been checked.	Mark Briggs

TABLE OF CONTENTS

COVER PAGE.....1

REVISION HISTORY2

TABLE OF CONTENTS3

LIST OF TABLES.....3

LIST OF FIGURES.....4

SCOPE.....5

OBJECTIVE.....5

STATEMENT OF COMPLIANCE.....5

DEVIATIONS FROM THE STANDARD.....5

EQUIPMENT UNDER TEST (EUT) DETAILS.....6

 GENERAL.....6

 ENCLOSURE.....6

 MODIFICATIONS.....6

 SUPPORT EQUIPMENT.....7

 EUT INTERFACE PORTS.....7

 EUT OPERATION.....7

TEST RESULTS.....8

 TEST RESULTS SUMMARY – FCC PART 15, CLIENT DEVICE.....8

 MEASUREMENT UNCERTAINTIES.....8

DFS TEST METHODS.....9

 RADIATED TEST METHOD.....9

DFS MEASUREMENT INSTRUMENTATION.....11

 RADAR GENERATION SYSTEM.....11

 CHANNEL MONITORING SYSTEM.....12

DFS MEASUREMENT METHODS.....13

 DFS – CHANNEL CLOSING TRANSMISSION TIME AND CHANNEL MOVE TIME.....13

 DFS – CHANNEL NON-OCCUPANCY AND VERIFICATION OF PASSIVE SCANNING.....13

 DFS CHANNEL AVAILABILITY CHECK TIME.....14

 TRANSMIT POWER CONTROL (TPC).....14

SAMPLE CALCULATIONS.....14

 DETECTION PROBABILITY / SUCCESS RATE.....14

 THRESHOLD LEVEL.....14

APPENDIX A TEST EQUIPMENT CALIBRATION DATA.....15

APPENDIX B TEST DATA TABLES AND PLOTS FOR CHANNEL CLOSING.....16

 FCC PART 15 SUBPART E CHANNEL CLOSING MEASUREMENTS.....16

APPENDIX C TEST CONFIGURATION PHOTOGRAPHS.....23

LIST OF TABLES

Table 1 FCC Part 15 Subpart E Client Device Test Result Summary..... 8

Table 2 FCC Part 15 Subpart E Channel Closing Test Results..... 16

LIST OF FIGURES

Figure 1 Test Configuration for radiated Measurement Method 9
Figure 2 Test Configuration for Conducted Measurement Method 10
Figure 3 Channel Closing Time and Channel Move Time – 40 second plot (20MHz BW) 17
Figure 4 Close-Up of Transmissions Occurring More Than 200ms After The End of Radar
(20MHz BW) 18
Figure 5 Channel Closing Time and Channel Move Time – 40 second plot (40MHz BW) 19
Figure 6 Close-Up of Transmissions Occurring More Than 200ms After The End of Radar
(40MHz BW) 20
Figure 7 Radar Channel Non-Occupancy Plot (Associated Test) 21
Figure 8 Confirmation of Passive Scanning For Client Devices (Non-associated Test)..... 22

SCOPE

The Federal Communications Commission and the European Telecommunications Standards Institute (ETSI) publish standards regarding ElectroMagnetic Compatibility and Radio spectrum Matters for radio-communications devices. Tests have been performed on the Intel Corporation model 512AN_MMW in accordance with these standards.

Test data has been taken pursuant to the relevant DFS requirements of the following standard.

- FCC Part 15 Subpart E Unlicensed National Information Infrastructure (U-NII) Devices

Tests were performed in accordance with these standards together with the current published versions of the basic standards referenced therein as outlined in Elliott Laboratories test procedures.

The test results recorded herein are based on a single type test of the Intel Corporation model 512AN_MMW and therefore apply only to the tested sample. The sample was selected and prepared under the authority of Robert Paxman of Intel.

OBJECTIVE

The objective of the manufacturer is to comply with the standards identified in the previous section. In order to demonstrate compliance, the manufacturer or a contracted laboratory makes measurements and takes the necessary steps to ensure that the equipment complies with the appropriate technical standards. Compliance with some DFS features is covered through a manufacturer statement or through observation of the device.

STATEMENT OF COMPLIANCE

The tested sample of Intel Corporation model 512AN_MMW complied with the DFS requirements of:

FCC Part 15.407(h)(2)

Maintenance of compliance is the responsibility of the manufacturer. Any modifications to the product should be assessed to determine their potential impact on the compliance status of the device with respect to the standards detailed in this test report.

DEVIATIONS FROM THE STANDARD

No deviations were made from the test methods and requirements covered by the scope of this report.

EQUIPMENT UNDER TEST (EUT) DETAILS**GENERAL**

The Intel Corporation model 512AN_MMW is a full- mini PCI Express 802.11 a/b/g/draft N v. 2.0 board that is designed to enable wireless data transmission in PCs. Since the EUT would be placed on a tabletop during operation, the EUT was treated as tabletop equipment during testing to simulate the end-user environment. The electrical rating of the EUT is 3.3 Vdc from the host.

The sample was received and tested on April 9, 2008. The EUT consisted of the following component(s):

Manufacturer	Model	Description	Serial Number
Intel Corporation	512AN_MMW	Full- mini PCI Express 802.11 a/b/g/draft N v. 2.0 board	0016EA01A17C

The manufacturer declared values for the EUT operational characteristics that affect DFS are as follows:

Operating Modes (5250 – 5350 MHz, 5470 – 5725 MHz)

- Master Device
- Client Device (no In Service Monitoring, no Ad-Hoc mode)
- Client Device with In-Service Monitoring

Antenna Gains / EIRP (5250 – 5350 MHz, 5470 – 5725 MHz)

	5250 – 5350 MHz	5470 – 5725 MHz
Lowest Antenna Gain (dBi)	5dBi	5dBi
Highest Antenna Gain (dBi)	5dBi	5dBi
Output Power (dBm)	14dBm	16.5dBm

- Power can exceed 200mW eirp

Channel Protocol

- IP Based

ENCLOSURE

The EUT has no enclosure; it is designed to be installed within the enclosure of a host computer.

MODIFICATIONS

The EUT did not require modifications during testing in order to comply with the requirements of the standard(s) referenced in this test report.

SUPPORT EQUIPMENT

The following equipment was used as local support equipment for testing:

Manufacturer	Model	Description	Serial Number	FCC ID
<i>Cisco Systems</i>	<i>Aironet 1250AG Series</i>	<i>Access Point</i>	<i>FTX1209906V</i>	<i>LDK102061</i>
Dell	Vostro 1710	Laptop Computer (Host)	Prototype	DoC

The italicized device was the master device.

EUT INTERFACE PORTS

The I/O cabling configuration during testing was as follows:

Port	Connected To	Cable(s)		
		Description	Shielded or Unshielded	Length (m)
None				

EUT OPERATION

The EUT was operating with the following software. The software is secured by binary encryption to prevent the user from disabling the DFS function.

Client Device: 12.0.0.56

During the channel moving tests the system was configured with a streaming video file from the master device (sourced by the PC connected to the master device via an Ethernet interface) to the client device.

The streamed file was the "FCC" test file and the client device was using Windows Media Player Classic as required by FCC Part 15 Subpart E

TEST RESULTS**TEST RESULTS SUMMARY – FCC Part 15, CLIENT DEVICE**

Table 1 FCC Part 15 Subpart E Client Device Test Result Summary						
Description	Radar Type	Radar Frequency	Measured Value	Requirement	Test Data	Status
Channel closing transmission time	Type 1	5260 (n 40MHz)	1.86ms	260ms	Appendix B	Complies
Channel move time	Type 1	5260 (n 40MHz)	0.485s	10s	Appendix B	Complies
Channel closing transmission time	Type 1	5560 (n 20MHz)	1.46ms	260ms	Appendix B	Complies
Channel move time	Type 1	5560 (n 20MHz)	0.537s	10s	Appendix B	Complies
Non-occupancy period - associated	Type 1	5500	>30min	> 30 minutes	Appendix B	Complies
Non-occupancy period – not associated	N/A	N/A	No transmissions observed	Passive Scanning	Appendix B	Complies

Notes:

- 1) Tests were performed using the radiated test method.
- 2) Channel availability check, detection threshold and non-occupancy period are not applicable to client devices.

MEASUREMENT UNCERTAINTIES

ISO/IEC 17025 requires that an estimate of the measurement uncertainties associated with the emissions test results be included in the report. The measurement uncertainties given below are based on a 95% confidence level, with a coverage factor (k=2) and were calculated in accordance with UKAS document LAB 34.

Measurement	Measurement Unit	Expanded Uncertainty
Timing (Channel move time, aggregate transmission time)	ms	Timing resolution +/- 0.24%
Timing (non occupancy period)	seconds	5 seconds
DFS Threshold (radiated)	dBm	1.6
DFS Threshold (conducted)	dBm	1.2

DFS TEST METHODS**RADIATED TEST METHOD**

The combination of master and slave devices is located in an anechoic chamber. The simulated radar waveform is transmitted from a directional horn antenna (typically an EMCO 3115) toward the unit performing the radar detection (radar detection device, RDD). Every effort is made to ensure that the main beam of the EUT's antenna is aligned with the radar generating antenna.

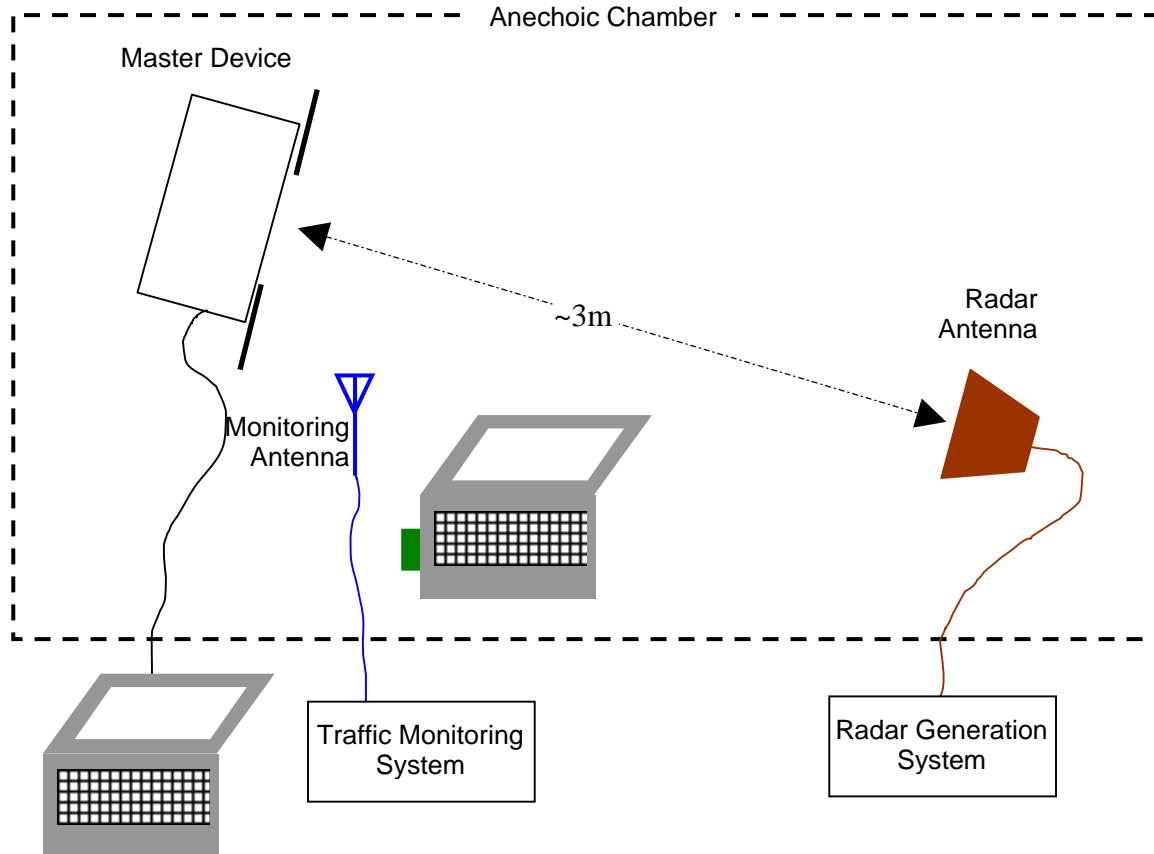

Figure 1 Test Configuration for radiated Measurement Method

The signal level of the simulated waveform is set to a reference level equal to the threshold level (plus 1dB if testing against FCC requirements). Lower levels may also be applied on request of the manufacturer. The level reported is the level at the RDD antenna and so it is not corrected for the RDD's antenna gain. The RDD is configured with the lowest gain antenna assembly intended for use with the device.

The signal level is verified by measuring the CW signal level from the radar generation system using a reference antenna of gain G (dBi). The radar signal level is calculated from the measured level, R (dBm), and any cable loss, L (dB), between the reference antenna and the measuring instrument:

$$\text{Applied level (dBm)} = R - \text{GREF} + L$$

If both master and client devices have radar detection capability then the device not under test is positioned with absorbing material between its antenna and the radar generating antenna, and the radar level at the non RDD is verified to be at least 20dB below the threshold level to ensure that any responses are due to the RDD detecting radar.

The antenna connected to the channel monitoring subsystem is positioned to allow both master and client transmissions to be observed, with the level of the EUT's transmissions between 6 and 10dB higher than those from the other device.

The combination of master and slave devices is located in an anechoic chamber. The simulated radar waveform is coupled into the unit performing the radar detection (radar detection device, RDD) via couplers and attenuators.

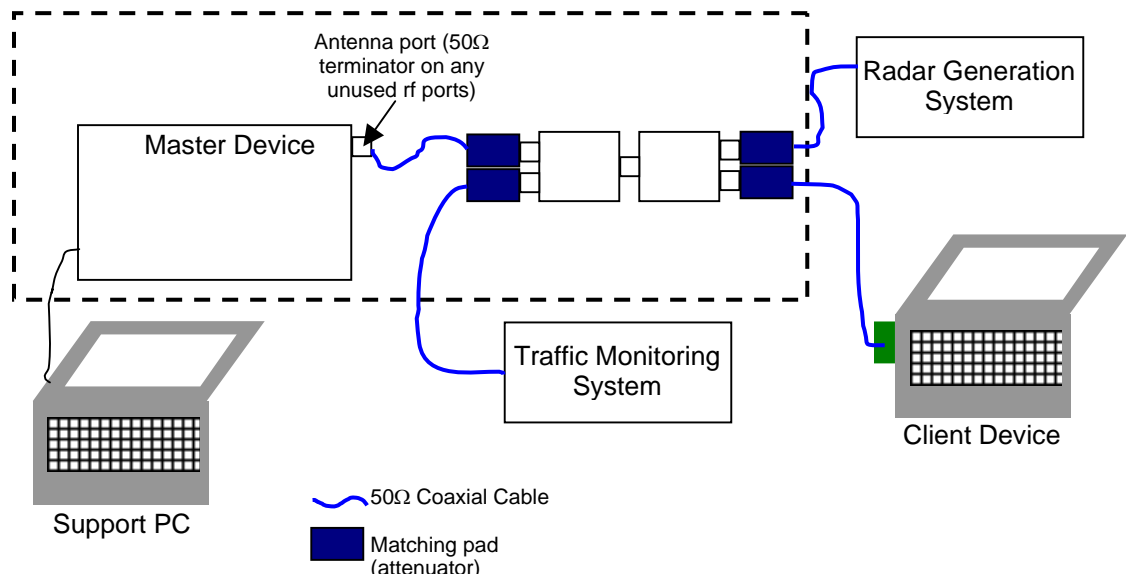

Figure 2 Test Configuration for Conducted Measurement Method

The signal level of the simulated waveform is set to a reference level equal to the threshold level (plus 1dB if testing against FCC requirements). Lower levels may also be applied on request of the manufacturer.

The signal level is verified by measuring the CW signal level at the coupling point to the RDD antenna port. The radar signal level is calculated from the measured level, R (dBm) and the lowest gain antenna assembly intended for use with the RDD, GRDD (dBi):

$$\text{Applied level (dBm)} = R - \text{GRDD}$$

If both master and client devices have radar detection capability then the radar level at the non RDD is verified to be at least 20dB below the threshold level to ensure that any responses are due to the RDD detecting radar.

The antenna connected to the channel monitoring subsystem is positioned to allow both master and client transmissions to be observed, with the level of the EUT's transmissions between 6 and 10dB higher than those from the other device.

DFS MEASUREMENT INSTRUMENTATION

RADAR GENERATION SYSTEM

An Agilent PSG is used as the radar-generating source. The integral arbitrary waveform generators are programmed using Agilent's "Pulse Building" software and Elliott custom software to produce the required waveforms, with the capability to produce both unmodulated and modulated (FM Chirp) pulses. Where there are multiple values for a specific radar parameter then the software selects a value at random and, for FCC tests, the software verifies that the resulting waveform is truly unique.

With the exception of the hopping waveforms required by the FCC's rules (see below), the radar generator is set to a single frequency within the radar detection bandwidth of the EUT.

Frequency hopping radar waveforms are simulated using a time domain model. A randomly hopping sequence algorithm (which uses each channel in the hopping radar's range once in a hopping sequence) generates a hop sequence. A segment of the first 100 elements of the hop sequence are then examined to determine if it contains one or more frequencies within the radar detection bandwidth of the EUT. If it does not then the first element of the segment is discarded and the next frequency in the sequence is added. The process repeats until a valid segment is produced. The radar system is then programmed to produce bursts at time slots coincident with the frequencies within the segment that fall in the detection bandwidth. The frequency of the generator is stepped in 1 MHz increments across the EUT's detection range.

The radar signal level is verified during testing using a CW signal with the AGC function switched on. Correction factors to account for the fact that pulses are generated with the AGC functions switched off are measured annually and an offset is used to account for this in the software.

The generator output is connected to the coupling port of the conducted set-up or to the radar generating antenna.

CHANNEL MONITORING SYSTEM

Channel monitoring is achieved using a spectrum analyzer and digital storage oscilloscope. The analyzer is configured in a zero-span mode, center frequency set to the radar waveform's frequency or the center frequency of the EUT's operating channel. The IF output of the analyzer is connected to one input of the oscilloscope.

A signal generator output is set to send either the modulating signal directly or a pulse gate with an output pulse co-incident with each radar pulse. This output is connected to a second input on the oscilloscope and the oscilloscope displays both the channel traffic (via the if input) and the radar pulses on its display.

For in service monitoring tests the analyzer sweep time is set to > 20 seconds and the oscilloscope is configured with a data record length of 10 seconds for the short duration and frequency hopping waveforms, 20 seconds for the long duration waveforms. Both instruments are set for a single acquisition sequence. The analyzer is triggered 500ms before the start of the waveform and the oscilloscope is triggered directly by the modulating pulse train. Timing measurements for aggregate channel transmission time and channel move time are made from the oscilloscope data, with the end of the waveform clearly identified by the pulse train on one trace. The analyzer trace data is used to confirm that the last transmission occurred within the 10 second record of the oscilloscope. If necessary the record length of the oscilloscope is expanded to capture the last transmission on the channel prior to the channel move.

Channel availability check time timing plots are made using the analyzer. The analyzer is triggered at start of the EUT's channel availability check and used to verify that the EUT does not transmit when radar is applied during the check time.

The analyzer detector and oscilloscope sampling mode is set to peak detect for all plots.

DFS MEASUREMENT METHODS

DFS – CHANNEL CLOSING TRANSMISSION TIME AND CHANNEL MOVE TIME

Channel clearing and closing times are measured by applying a burst of radar with the device configured to change channel and by observing the channel for transmissions. The time between the end of the applied radar waveform and the final transmission on the channel is the channel move time.

The aggregate transmission closing time is measured in one of two ways:

FCC – the total time of all individual transmissions from the EUT that are observed starting 200ms at the end of the last radar pulse in the waveform. This value is required to be less than 60ms.

DFS – CHANNEL NON-OCCUPANCY AND VERIFICATION OF PASSIVE SCANNING

The channel that was in use prior to radar detection by the master is additionally monitored for 30 minutes to ensure no transmissions on the vacated channel over the required non-occupancy period. This is achieved by tuning the spectrum analyzer to the vacated channel in zero-span mode and connecting the IF output to an oscilloscope. The oscilloscope is triggered by the radar pulse and set to provide a single sweep (in peak detect mode) that lasts for at least 30 minutes after the end of the channel move time.

For devices with a client-mode that are being evaluated against FCC rules the complete spectrum of operation requiring DFS is monitored for a period of 30 minutes with the master device switched off to verify that the client device does not employ any active scanning techniques (i.e. does not transmit in the DFS bands without authorization from a Master device). This is achieved by tuning the spectrum analyzer to the master's operating channel in zero-span mode and connecting the IF output to an oscilloscope. The oscilloscope is manually triggered once the master has powered down to provide a single sweep (in peak detect mode) that lasts for at least 30 minutes after the end of the channel move time.

DFS CHANNEL AVAILABILITY CHECK TIME

It is preferred that the EUT report when it starts the radar channel availability check. In this case a single burst of one radar type is applied within the first 2 seconds of the start of the channel availability check and it is verified that the device does not use the channel. The test is repeated by applying a radar burst in the last 2 seconds (i.e. between 58 and 60 seconds after the start of CAC) of the channel availability check.

If the EUT does not report the start of the check time, then the time to start transmitting on a channel after switching the device on is measured to approximate the time from power-on to the end of the channel availability check. The start of the channel availability check is assumed to be 60 seconds prior to the first transmission on the channel.

TRANSMIT POWER CONTROL (TPC)

Compliance with the transmit power control requirements for devices is demonstrated through measurements showing multiple power levels and manufacturer statements explaining how the power control is implemented.

SAMPLE CALCULATIONS

DETECTION PROBABILITY / SUCCESS RATE

The detection probability, or success rate, for any one radar waveform equals the number of successful trials divided by the total number of trials for that waveform.

THRESHOLD LEVEL

The threshold level is the level of the simulated radar waveform at the EUT's antenna. If the test is performed in a conducted fashion then the level at the rf input equals the level at the antenna plus the gain of the antenna assembly, in dBi. The gain of the antenna assembly equals the gain of the antenna minus the loss of the cabling between the rf input and the antenna. The lowest gain value for all antenna assemblies intended for use with the device is used when making this calculation.

If the test is performed using the radiated method then the threshold level is the level at the antenna.

Appendix A Test Equipment Calibration Data

<u>Manufacturer</u>	<u>Description</u>	<u>Model #</u>	<u>Asset #</u>	<u>Cal Due</u>
Hewlett Packard	Spectrum Analyzer	8595EM	780	09-Oct-08
Tektronix	Digital Oscilloscope	TDS 5034B	Rental (020408)	04-Apr-09
Agilent Technologies	PSG Vector Signal Generator	E8267C	1877	23-Jan-08
EMCO	1-18GHz Horn Antenna	3115	868	24-Apr-08
ETS Lindgren	1-18GHz Horn Antenna	3117	1662	21-Mar-08

Appendix B Test Data Tables and Plots for Channel Closing

FCC PART 15 SUBPART E Channel Closing Measurements

Table 2 FCC Part 15 Subpart E Channel Closing Test Results					
Waveform Type	Channel Closing Transmission Time ¹		Channel Move Time		Result
	Measured	Limit	Measured	Limit	
Radar Type 1, 20MHz BW	1.46	60 ms	0.537 s	10 s	Complied
Radar Type 1, 40MHz BW	1.86	60 ms	0.485 s	10 s	Complied

After the final channel closing test the channel was monitored for a further 30 minutes. No transmissions occurred on the channel.

¹ Channel closing time for FCC measurements is the aggregate transmission time starting from 200ms after the end of the radar signal to the completion of the channel move.

Elliott Timing Plots - Channel Closing

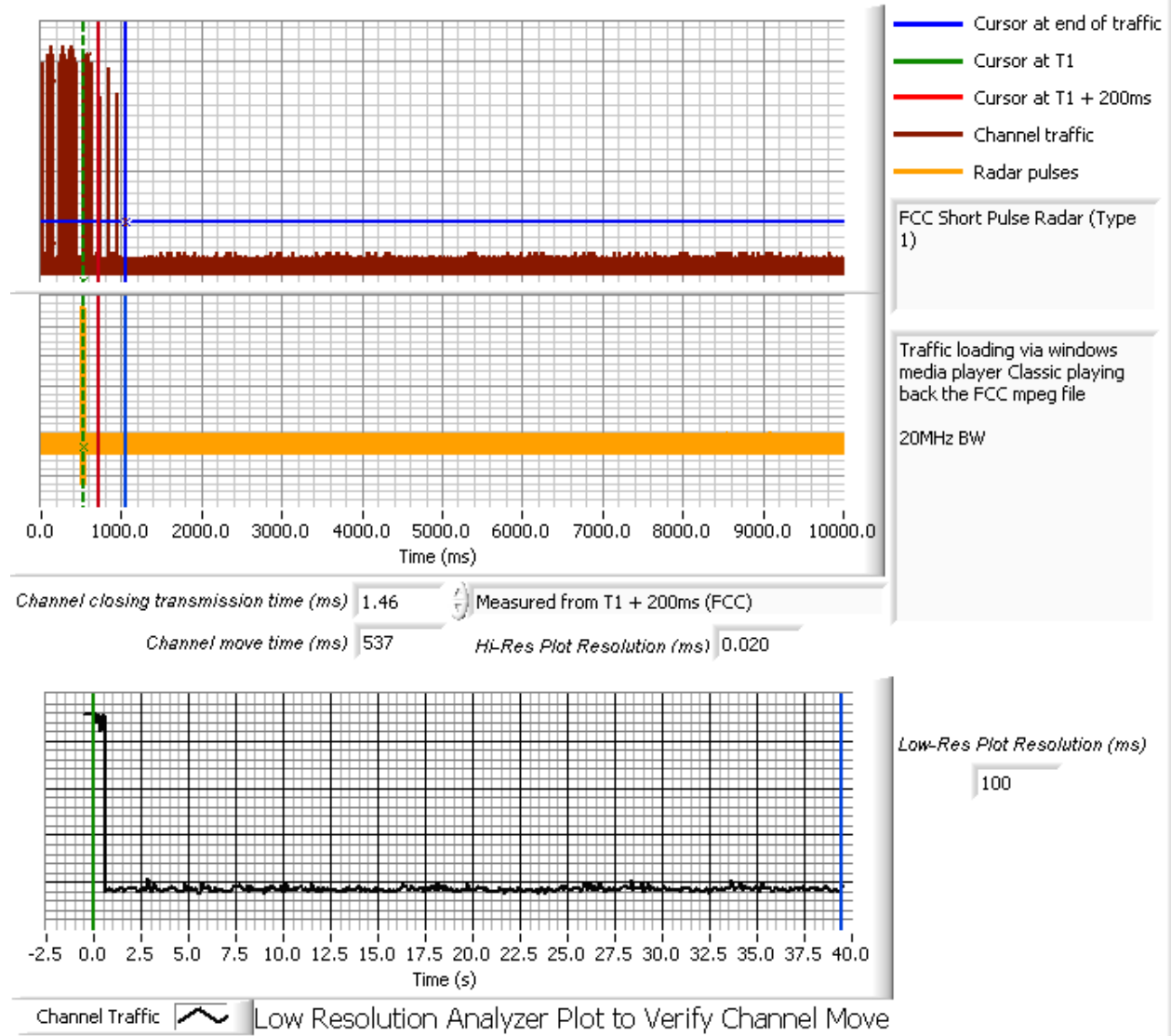

Figure 3 Channel Closing Time and Channel Move Time – 40 second plot (20MHz BW)

Elliott Timing Plots - Channel Closing

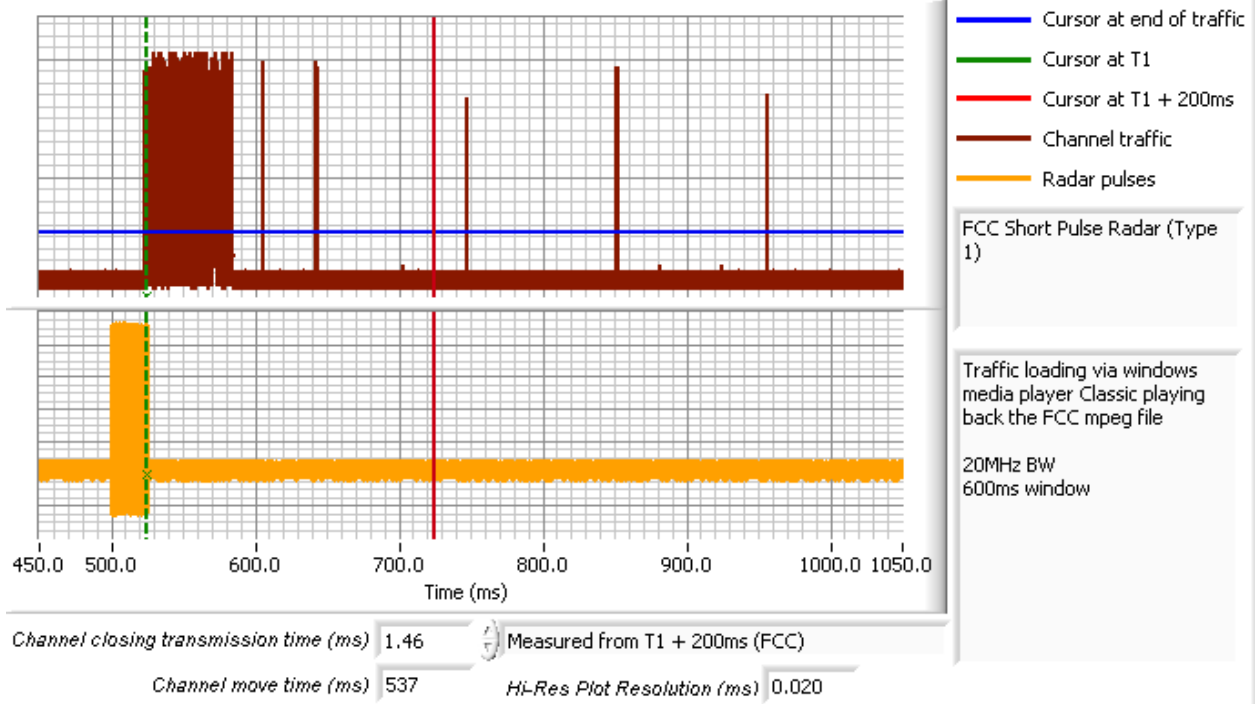

Figure 4 Close-Up of Transmissions Occurring More Than 200ms After The End of Radar (20MHz BW)

Short duration signals occurring after the first 200ms immediately following the radar burst, with a total transmission time of 1.46ms.

Elliott Timing Plots - Channel Closing

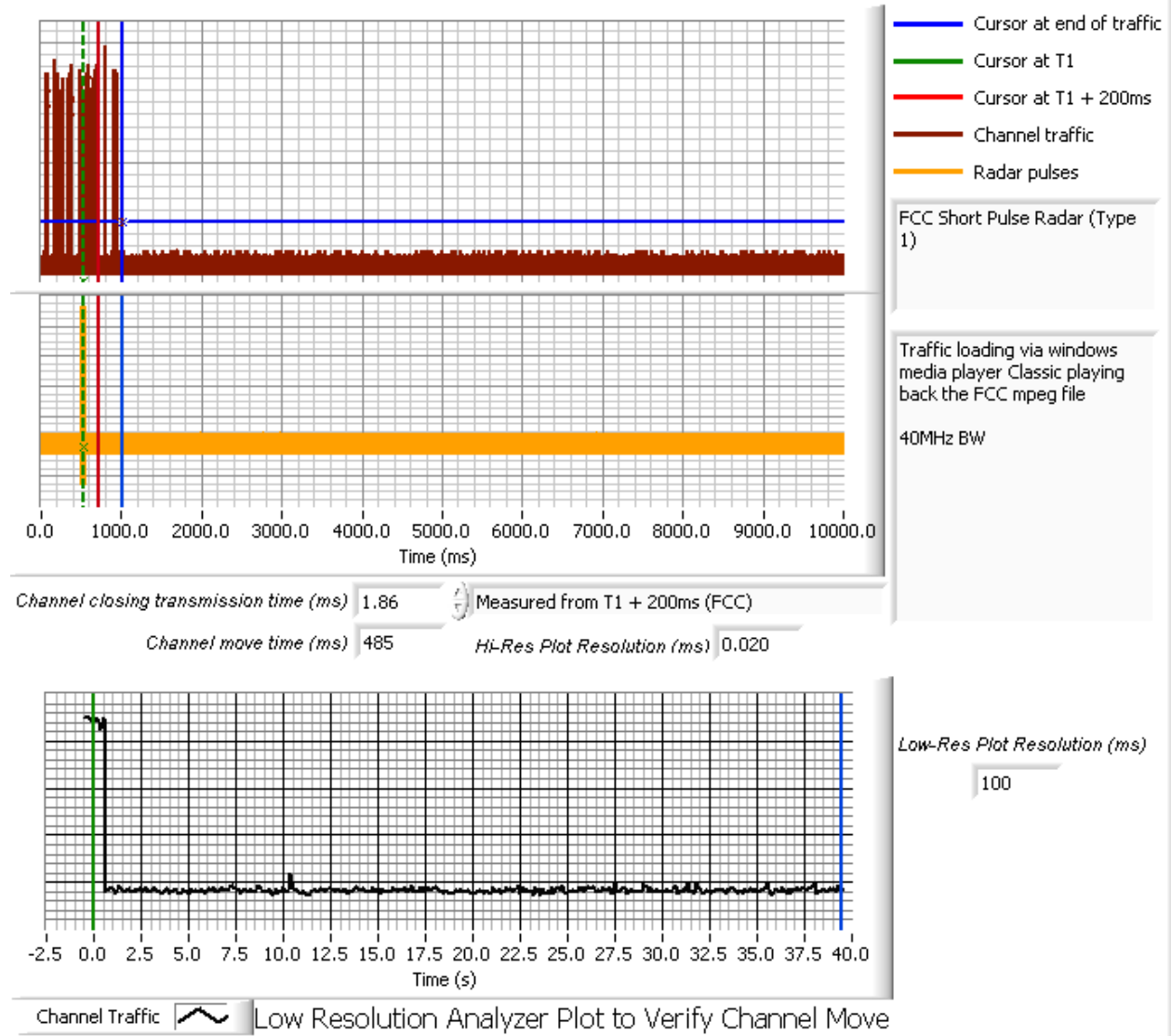

Figure 5 Channel Closing Time and Channel Move Time – 40 second plot (40MHz BW)

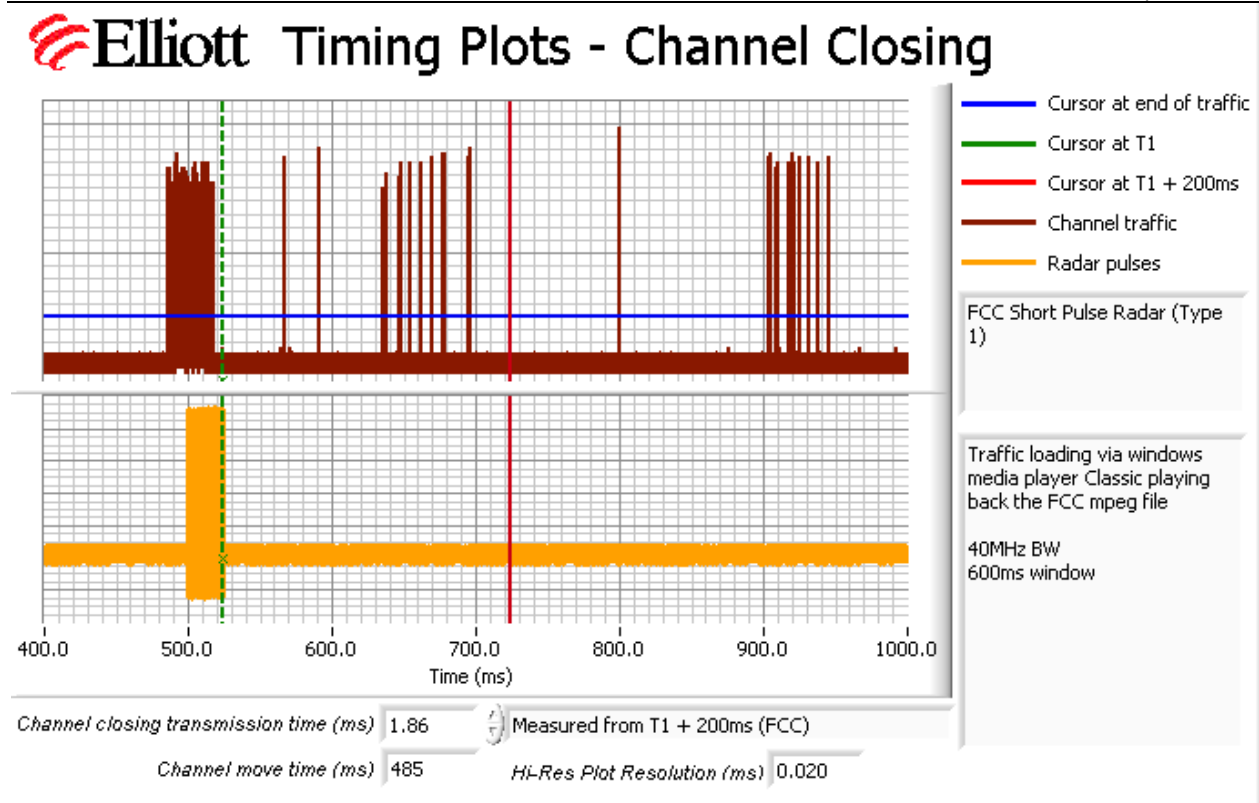

Figure 6 Close-Up of Transmissions Occurring More Than 200ms After The End of Radar (40MHz BW)

Short duration signals occurring after the first 200ms immediately following the radar burst, with a total transmission time of 1.86ms.

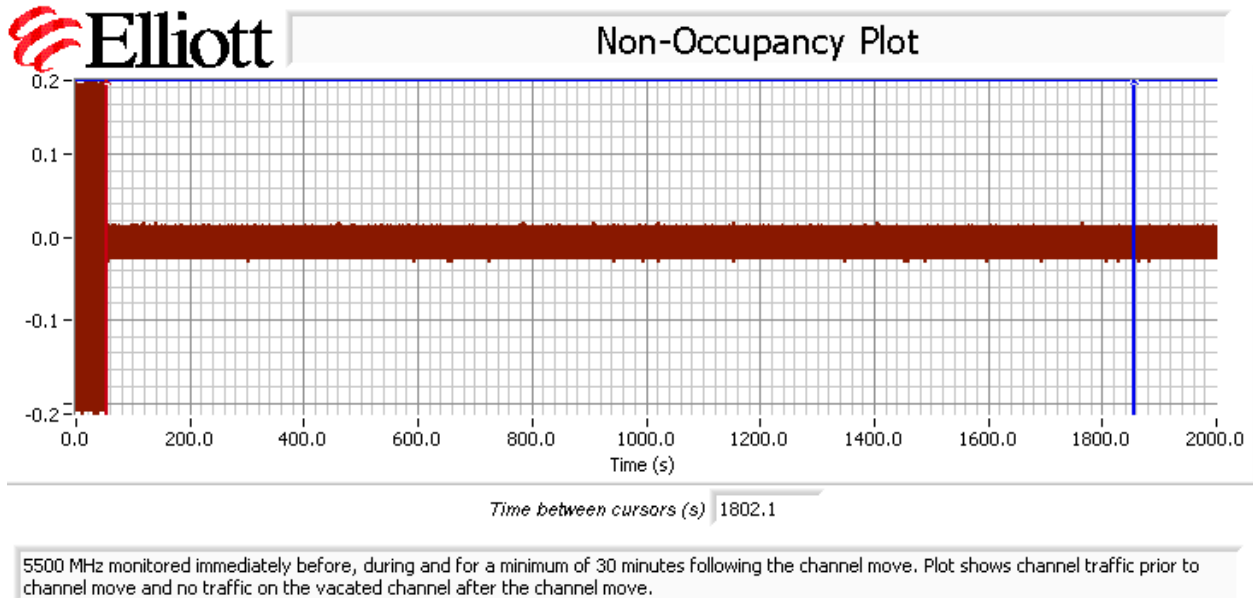

Figure 7 Radar Channel Non-Occupancy Plot (Associated Test)

The non-occupancy plot was made over a 30-minute time period following the channel move time with the analyzer IF output connected to the scope and tuned to the vacated channel. No transmissions were observed after the channel move had been completed the channel move completed at the red cursor).

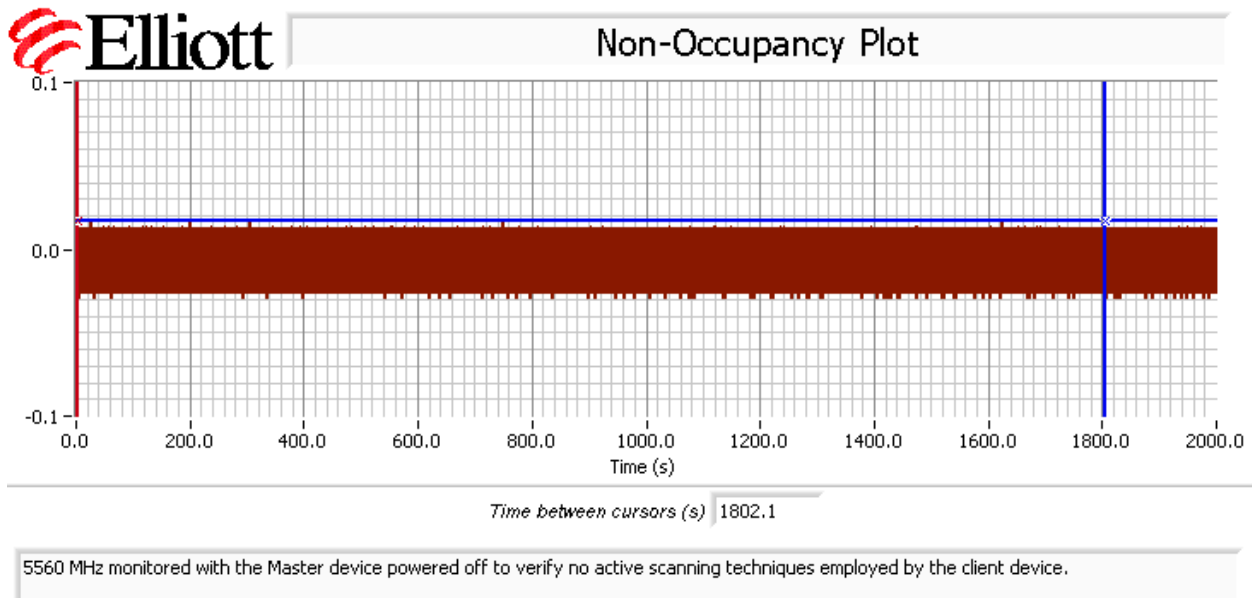

Figure 8 Confirmation of Passive Scanning For Client Devices (Non-associated Test)

The plot used to verify passive scanning in the non-associated non-occupancy test was made over a 30-minute time period with the analyzer IF output connected to the scope and tuned to the previously occupied channel to confirm that there were no transmissions from the Client device with the Master device powered off. No transmissions were observed.

Appendix C Test Configuration Photographs

