

Class II Permissive Change
Test Report
And Application for Grant of Equipment Authorization

TEST REPORT PERTAINING TO:

| Equipment Under Test | Model Number(s) |
|----------------------------------|-----------------|
| Intel Wireless WiFi Link 4965AGN | 4965AGN |

| CONFIGURATION |
|--|
| 802.11a / 802.11b / 802.11g / 802.11n with a set of Sony IRX-3980 Antennas |

MEASUREMENTS PERFORMED IN ACCORDANCE WITH THE FOLLOWING STANDARD (S)

| Regulatory Standard(s) |
|--|
| 47 CFR Part 15, Subpart E Section 15.407 (UNII Devices) |
| Test Method: ANSI C63.4: 2003 American National Standard for Methods of Measurement of Radio-Noise Emissions from Low-Voltage Electrical and Electronic Equipment in the Range of 9 kHz to 40 GHz |



Certificate Number: 1111.01

PREPARED FOR:

Intel Corporation
2111 NE 25th Avenue
Hillsboro, Oregon 97124
Contact(s): Mr. Robert Paxman

PREPARED BY:

Aegis Labs, Inc.
22431 Antonio Parkway B160-417
Rancho S. Margarita, CA 92688
Agent(s): Mr. Rick Candelas
Mr. Johnny Candelas



Test Report #: INTEL-070321F

Test Report Revision: NONE

| | REPORT BODY | APPENDICES | | TOTAL PAGES |
|-------|-------------|------------|---|-------------|
| | | A | B | |
| PAGES | 17 | 70 | 1 | 88 |

The contents of this report shall not be reproduced except in full, without the written approval of Aegis Labs, Inc.
The Intel logo is used for identification purposes only and is a registered trademark of Intel Corporation



TABLE OF CONTENTS

| SECTION | TITLE | PAGE |
|------------|---|-----------|
| | COVER SHEET..... | 01 |
| | TABLE OF CONTENTS..... | 02 |
| 1.0 | REGULATORY COMPLIANCE GUIDELINES..... | 03 |
| 1.1 | Guidelines For Testing To Emissions Standards..... | 03 |
| 2.0 | SUMMARY OF REGULATORY LIMITS..... | 04 |
| 3.0 | ADMINISTRATIVE DATA AND TEST DESCRIPTION..... | 11 |
| 4.0 | DESCRIPTION OF EUT CONFIGURATION..... | 12 |
| 4.1 | EUT Description | 12 |
| 4.2 | EUT Configuration..... | 13 |
| 4.3 | List of EUT Sub-Assemblies and Host Equipment..... | 13 |
| 4.4 | I/O Cabling Diagram and Description | 14 |
| 4.5 | EMC Test Hardware and Software Measurement Equipment..... | 15 |
| 5.0 | CONDITIONS DURING EMISSIONS MEASUREMENTS..... | 16 |
| 5.1 | General..... | 16 |
| 5.2 | Conducted Emissions Test Setup..... | 16 |
| 5.3 | Radiated Emissions Test Setup..... | 17 |

APPENDICES

| | |
|----------|-----------------------------------|
| A | Test Data |
| B | Modifications And Recommendations |



1.0 REGULATORY COMPLIANCE GUIDELINES

Aegis Labs, Inc. operates as both a Nevada and California Corporation with no organizational or financial relationship with any company, institution, or private individual. Testing and engineering functions provided by Aegis Labs were furnished by RF technicians and engineers with accredited qualifications and training credentials to carry out their duties.

The object of this report was to publish verifiable test results of an EUT subjected to the tests outlined in the standard listed on the cover page of this report.

1.1 Guidelines For Testing To Emissions Standards

This standard for EMC emission requirements apply to electrical equipment for Information Technology Equipment (ITE). Compliance to these standards and in combination with the other standards listed in this test report can be used to demonstrate presumption of compliance with the protection requirements of the appropriate agency standard.

The purpose of this standard is to specify minimum requirements for emissions regarding electromagnetic compatibility (EMC) and protect the radio frequency spectrum 9 kHz. – 400 GHz. from unwanted interference generated from electrical/digital systems that intentionally or unintentionally generated RF energy. The emissions standards, normative documents and/or publications were used to conduct all tests performed on the equipment herein referred to as “Equipment Under Test”.



2.0 SUMMARY OF TEST RESULTS

802.11a Mode (5150-5350 MHz) Chain A

| EMISSIONS STANDARD | | | |
|--|--|---------|--|
| FCC Part 15 Section | Description | Results | Comments |
| Operation in the 5.15-5.25 GHz Band | | | |
| 15.407(d) | Any UNII device shall use a transmitting antenna that is an integral part of the device. | PASSED | The antenna will be integral when installed in a notebook computer |
| 15.407(e) | UNII devices will be restricted to indoor operations. | PASSED | Refer to "User's Manual" Exhibit |
| 15.407(a)(1) | 26dB emissions bandwidth in MHz. | N/A | 5.18 GHz = 22.00 MHz <i>Per Original Filing</i> |
| 15.407(a)(1) | Peak transmit power shall not exceed the lesser of 50mW or 4dBm+10logB (where B = 26dB emissions bandwidth). | PASSED | 5.18 GHz = 16.61dBm (45.81mW) 5.24 GHz = 16.81dBm (47.97mW) |
| 15.407(a)(1) | The peak power spectral density shall not exceed 4dBm in any 1MHz band. | PASSED | 5.18 GHz = -15.06dBm <i>Per Original Filing</i> |
| 15.407(a)(1) | Peak transmit power and the peak power spectral density shall be reduced by the amount in dB that the transmitting antenna exceeds 6dBi. | N/A | All antennas tested have less than 6dBi antenna gain (Please see the antenna data sheets) |
| 15.407(b)(6) 15.209 | Unwanted emissions below 1 GHz must comply with the general field strength limits set forth in Section 15.209. | PASSED | <i>See Original Filing</i> |
| 15.407(b)(1) | All emissions outside of the 5.15-5.35 GHz band shall not exceed an EIRP of -27dBm/MHz. | PASSED | See Data Sheets |
| Operation in the 5.25-5.35 GHz Band | | | |
| 15.407(a)(2) | 26dB emissions bandwidth in MHz. | N/A | 5.26 GHz = 22.42 MHz 5.32 GHz = 21.50 MHz <i>Per Original Filing</i> |
| 15.407(a)(2) | Peak transmit power shall not exceed the lesser of 250mW or 11dBm+10logB (where B = 26dB emissions bandwidth). | PASSED | 5.26 GHz = 18.61dBm (72.60mW) 5.32 GHz = 18.41dBm (69.34mW) |
| 15.407(a)(2) | The peak power spectral density shall not exceed 11dBm in any 1MHz band. | PASSED | 5.26 GHz = 9.50dBm 5.32 GHz = 9.83dBm <i>Per Original Filing</i> |
| 15.407(a)(2) | Peak transmit power and the peak power spectral density shall be reduced by the amount in dB that the transmitting antenna exceeds 6dBi. | N/A | All antennas tested have less than 6dBi antenna gain (Please see the antenna data sheets) |
| 15.407(b)(6) 15.209 | Unwanted emissions below 1 GHz must comply with the general field strength limits set forth in Section 15.209. | PASSED | <i>See Original Filing</i> |
| 15.407(b)(2) | All emissions outside of the 5.15-5.35 GHz band shall not exceed an EIRP of -27dBm/MHz. Must meet all applicable technical requirements for operating in the 5.15-5.25 GHz band. | PASSED | See Data Sheets |
| General Requirements For All Bands | | | |
| 15.407(a)(6) | The ratio of the peak excursion of the modulation envelope to the peak transmit power shall not exceed 13dB across any 1 MHz bandwidth or the emissions bandwidth whichever is less. | PASSED | 5.18 GHz = 5.83 dB 5.26 GHz = 5.67 dB 5.32 GHz = 5.50 dB <i>Per Original Filing</i> |
| 15.407(f) | Radio frequency radiation exposure requirement. | PASSED | Refer to MPE Calculations Exhibit |
| 15.407(b)(6) 15.207 | UNII devices using AC power line are required to comply with the conducted limits set forth in Section 15.207. | PASSED | <i>See Original Filing</i> |

2.0 Summary Of Test Results (Continued)

802.11a Mode (5150-5350 MHz) Chain B

| EMISSIONS STANDARD | | | |
|--|--|----------------|--|
| FCC Part 15 Section | Description | Results | Comments |
| Operation in the 5.15-5.25 GHz Band | | | |
| 15.407(d) | Any UNII device shall use a transmitting antenna that is an integral part of the device. | PASSED | The antenna will be integral when installed in a notebook computer |
| 15.407(e) | UNII devices will be restricted to indoor operations. | PASSED | Refer to "User's Manual" Exhibit |
| 15.407(a)(1) | 26dB emissions bandwidth in MHz. | N/A | 5.18 GHz = 23.50 MHz <i>Per Original Filing</i> |
| 15.407(a)(1) | Peak transmit power shall not exceed the lesser of 50mW or 4dBm+10logB (where B = 26dB emissions bandwidth). | PASSED | 5.18 GHz = 16.81dBm (47.97mW) 5.24 GHz = 16.91dBm (49.09mW) |
| 15.407(a)(1) | The peak power spectral density shall not exceed 4dBm in any 1MHz band. | PASSED | 5.18 GHz = -13.62dBm <i>Per Original Filing</i> |
| 15.407(a)(1) | Peak transmit power and the peak power spectral density shall be reduced by the amount in dB that the transmitting antenna exceeds 6dBi. | N/A | All antennas tested have less than 6dBi antenna gain (Please see the antenna data sheets) |
| 15.407(b)(6) 15.209 | Unwanted emissions below 1 GHz must comply with the general field strength limits set forth in Section 15.209. | PASSED | <i>See Original Filing</i> |
| 15.407(b)(1) | All emissions outside of the 5.15-5.35 GHz band shall not exceed an EIRP of -27dBm/MHz. | PASSED | See Data Sheets |
| Operation in the 5.25-5.35 GHz Band | | | |
| 15.407(a)(2) | 26dB emissions bandwidth in MHz. | N/A | 5.26 GHz = 23.75 MHz 5.32 GHz = 22.33 MHz <i>Per Original Filing</i> |
| 15.407(a)(2) | Peak transmit power shall not exceed the lesser of 250mW or 11dBm+10logB (where B = 26dB emissions bandwidth). | PASSED | 5.26 GHz = 19.41dBm (87.29mW) 5.32 GHz = 19.11dBm (81.46mW) |
| 15.407(a)(2) | The peak power spectral density shall not exceed 11dBm in any 1MHz band. | PASSED | 5.26 GHz = 9.83dBm 5.32 GHz = 9.33dBm <i>Per Original Filing</i> |
| 15.407(a)(2) | Peak transmit power and the peak power spectral density shall be reduced by the amount in dB that the transmitting antenna exceeds 6dBi. | N/A | All antennas tested have less than 6dBi antenna gain (Please see the antenna data sheets) |
| 15.407(b)(6) 15.209 | Unwanted emissions below 1 GHz must comply with the general field strength limits set forth in Section 15.209. | PASSED | <i>See Original Filing</i> |
| 15.407(b)(2) | All emissions outside of the 5.15-5.35 GHz band shall not exceed an EIRP of -27dBm/MHz. Must meet all applicable technical requirements for operating in the 5.15-5.25 GHz band. | PASSED | See Data Sheets |
| General Requirements For All Bands | | | |
| 15.407(a)(6) | The ratio of the peak excursion of the modulation envelope to the peak transmit power shall not exceed 13dB across any 1 MHz bandwidth or the emissions bandwidth whichever is less. | PASSED | 5.18 GHz = 6.17 dB 5.26 GHz = 6.17 dB 5.32 GHz = 5.83 dB <i>Per Original Filing</i> |
| 15.407(f) | Radio frequency radiation exposure requirement. | PASSED | Refer to MPE Calculations Exhibit |
| 15.407(b)(6) 15.207 | UNII devices using AC power line are required to comply with the conducted limits set forth in Section 15.207. | PASSED | <i>See Original Filing</i> |



2.0 Summary Of Test Results (Continued)

802.11n Mode 20MHz Wide (5150-5350 MHz) Chain A

| EMISSIONS STANDARD | | | |
|--|--|----------------|--|
| FCC Part 15 Section | Description | Results | Comments |
| Operation in the 5.15-5.25 GHz Band | | | |
| 15.407(d) | Any UNII device shall use a transmitting antenna that is an integral part of the device. | PASSED | The antenna will be integral when installed in a notebook computer |
| 15.407(e) | UNII devices will be restricted to indoor operations. | PASSED | Refer to "User's Manual" Exhibit |
| 15.407(a)(1) | 26dB emissions bandwidth in MHz. | N/A | 5.18 GHz = 23.67 MHz <i>Per Original Filing</i> |
| 15.407(a)(1) | Peak transmit power shall not exceed the lesser of 50mW or 4dBm+10logB (where B = 26dB emissions bandwidth). | PASSED | 5.18 GHz = 16.91dBm (49.09mW) 5.24 GHz = 16.71dBm (46.88mW) |
| 15.407(a)(1) | The peak power spectral density shall not exceed 4dBm in any 1MHz band. | PASSED | 5.18 GHz = -13.99dBm <i>Per Original Filing</i> |
| 15.407(a)(1) | Peak transmit power and the peak power spectral density shall be reduced by the amount in dB that the transmitting antenna exceeds 6dBi. | N/A | All antennas tested have less than 6dBi antenna gain (Please see the antenna data sheets) |
| 15.407(b)(6) 15.209 | Unwanted emissions below 1 GHz must comply with the general field strength limits set forth in Section 15.209. | PASSED | <i>See Original Filing</i> |
| 15.407(b)(1) | All emissions outside of the 5.15-5.35 GHz band shall not exceed an EIRP of -27dBm/MHz. | PASSED | See Data Sheets |
| Operation in the 5.25-5.35 GHz Band | | | |
| 15.407(a)(2) | 26dB emissions bandwidth in MHz. | N/A | 5.26 GHz = 22.75 MHz 5.32 GHz = 22.33 MHz <i>Per Original Filing</i> |
| 15.407(a)(2) | Peak transmit power shall not exceed the lesser of 250mW or 11dBm+10logB (where B = 26dB emissions bandwidth). | PASSED | 5.26 GHz = 18.81dBm (76.03mW) 5.32 GHz = 18.41dBm (69.34mW) |
| 15.407(a)(2) | The peak power spectral density shall not exceed 11dBm in any 1MHz band. | PASSED | 5.26 GHz = 9.83dBm 5.32 GHz = 9.67dBm <i>Per Original Filing</i> |
| 15.407(a)(2) | Peak transmit power and the peak power spectral density shall be reduced by the amount in dB that the transmitting antenna exceeds 6dBi. | N/A | All antennas tested have less than 6dBi antenna gain (Please see the antenna data sheets) |
| 15.407(b)(6) 15.209 | Unwanted emissions below 1 GHz must comply with the general field strength limits set forth in Section 15.209. | PASSED | <i>See Original Filing</i> |
| 15.407(b)(2) | All emissions outside of the 5.15-5.35 GHz band shall not exceed an EIRP of -27dBm/MHz. Must meet all applicable technical requirements for operating in the 5.15-5.25 GHz band. | PASSED | See Data Sheets |
| General Requirements For All Bands | | | |
| 15.407(a)(6) | The ratio of the peak excursion of the modulation envelope to the peak transmit power shall not exceed 13dB across any 1 MHz bandwidth or the emissions bandwidth whichever is less. | PASSED | 5.18 GHz = 6.17 dB 5.26 GHz = 4.84 dB 5.32 GHz = 5.00 dB <i>Per Original Filing</i> |
| 15.407(f) | Radio frequency radiation exposure requirement. | PASSED | Refer to MPE Calculations Exhibit |
| 15.407(b)(6) 15.207 | UNII devices using AC power line are required to comply with the conducted limits set forth in Section 15.207. | PASSED | <i>See Original Filing</i> |

2.0 Summary Of Test Results (Continued)

802.11n Mode 20MHz Wide (5150-5350 MHz) Chain B

| EMISSIONS STANDARD | | | |
|--|--|---------|--|
| FCC Part 15 Section | Description | Results | Comments |
| Operation in the 5.15-5.25 GHz Band | | | |
| 15.407(d) | Any UNII device shall use a transmitting antenna that is an integral part of the device. | PASSED | The antenna will be integral when installed in a notebook computer |
| 15.407(e) | UNII devices will be restricted to indoor operations. | PASSED | Refer to "User's Manual" Exhibit |
| 15.407(a)(1) | 26dB emissions bandwidth in MHz. | N/A | 5.18 GHz = 23.25 MHz <i>Per Original Filing</i> |
| 15.407(a)(1) | Peak transmit power shall not exceed the lesser of 50mW or 4dBm+10logB (where B = 26dB emissions bandwidth). | PASSED | 5.18 GHz = 16.71dBm (46.88mW) 5.24 GHz = 16.81dBm (47.97mW) |
| 15.407(a)(1) | The peak power spectral density shall not exceed 4dBm in any 1MHz band. | PASSED | 5.18 GHz = -12.67dBm <i>Per Original Filing</i> |
| 15.407(a)(1) | Peak transmit power and the peak power spectral density shall be reduced by the amount in dB that the transmitting antenna exceeds 6dBi. | N/A | All antennas tested have less than 6dBi antenna gain (Please see the antenna data sheets) |
| 15.407(b)(6) 15.209 | Unwanted emissions below 1 GHz must comply with the general field strength limits set forth in Section 15.209. | PASSED | <i>See Original Filing</i> |
| 15.407(b)(1) | All emissions outside of the 5.15-5.35 GHz band shall not exceed an EIRP of -27dBm/MHz. | PASSED | See Data Sheets |
| Operation in the 5.25-5.35 GHz Band | | | |
| 15.407(a)(2) | 26dB emissions bandwidth in MHz. | N/A | 5.26 GHz = 23.00 MHz 5.32 GHz = 22.75 MHz <i>Per Original Filing</i> |
| 15.407(a)(2) | Peak transmit power shall not exceed the lesser of 250mW or 11dBm+10logB (where B = 26dB emissions bandwidth). | PASSED | 5.26 GHz = 19.21dBm (83.36mW) 5.32 GHz = 18.71dBm (74.29mW) |
| 15.407(a)(2) | The peak power spectral density shall not exceed 11dBm in any 1MHz band. | PASSED | 5.26 GHz = 10.00dBm 5.32 GHz = 10.00dBm <i>Per Original Filing</i> |
| 15.407(a)(2) | Peak transmit power and the peak power spectral density shall be reduced by the amount in dB that the transmitting antenna exceeds 6dBi. | N/A | All antennas tested have less than 6dBi antenna gain (Please see the antenna data sheets) |
| 15.407(b)(6) 15.209 | Unwanted emissions below 1 GHz must comply with the general field strength limits set forth in Section 15.209. | PASSED | <i>See Original Filing</i> |
| 15.407(b)(2) | All emissions outside of the 5.15-5.35 GHz band shall not exceed an EIRP of -27dBm/MHz. Must meet all applicable technical requirements for operating in the 5.15-5.25 GHz band. | PASSED | See Data Sheets |
| General Requirements For All Bands | | | |
| 15.407(a)(6) | The ratio of the peak excursion of the modulation envelope to the peak transmit power shall not exceed 13dB across any 1 MHz bandwidth or the emissions bandwidth whichever is less. | PASSED | 5.18 GHz = 5.00 dB 5.26 GHz = 5.67 dB 5.32 GHz = 5.67 dB <i>Per Original Filing</i> |
| 15.407(f) | Radio frequency radiation exposure requirement. | PASSED | Refer to MPE Calculations Exhibit |
| 15.407(b)(6) 15.207 | UNII devices using AC power line are required to comply with the conducted limits set forth in Section 15.207. | PASSED | <i>See Original Filing</i> |



2.0 Summary Of Test Results (Continued)

802.11n Mode 40MHz Wide (5150-5350 MHz) Chain A

| EMISSIONS STANDARD | | | |
|--|--|---------|--|
| FCC Part 15 Section | Description | Results | Comments |
| Operation in the 5.15-5.25 GHz Band | | | |
| 15.407(d) | Any UNII device shall use a transmitting antenna that is an integral part of the device. | PASSED | The antenna will be integral when installed in a notebook computer |
| 15.407(e) | UNII devices will be restricted to indoor operations. | PASSED | Refer to "User's Manual" Exhibit |
| 15.407(a)(1) | 26dB emissions bandwidth in MHz. | N/A | 5.19 GHz = 40.50 MHz <i>Per Original Filing</i> |
| 15.407(a)(1) | Peak transmit power shall not exceed the lesser of 50mW or 4dBm+10logB (where B = 26dB emissions bandwidth). | PASSED | 5.19 GHz = 16.51dBm (44.76mW) |
| 15.407(a)(1) | The peak power spectral density shall not exceed 4dBm in any 1MHz band. | PASSED | 5.19 GHz = -22.79dBm <i>Per Original Filing</i> |
| 15.407(a)(1) | Peak transmit power and the peak power spectral density shall be reduced by the amount in dB that the transmitting antenna exceeds 6dBi. | N/A | All antennas tested have less than 6dBi antenna gain (Please see the antenna data sheets) |
| 15.407(b)(6) 15.209 | Unwanted emissions below 1 GHz must comply with the general field strength limits set forth in Section 15.209. | PASSED | <i>See Original Filing</i> |
| 15.407(b)(1) | All emissions outside of the 5.15-5.35 GHz band shall not exceed an EIRP of -27dBm/MHz. | PASSED | See Data Sheets |
| Operation in the 5.25-5.35 GHz Band | | | |
| 15.407(a)(2) | 26dB emissions bandwidth in MHz. | N/A | 5.27 GHz = 47.50 MHz 5.31 GHz = 39.70 MHz <i>Per Original Filing</i> |
| 15.407(a)(2) | Peak transmit power shall not exceed the lesser of 250mW or 11dBm+10logB (where B = 26dB emissions bandwidth). | PASSED | 5.27 GHz = 18.51dBm (70.95mW) 5.31 GHz = 16.41dBm (43.74mW) |
| 15.407(a)(2) | The peak power spectral density shall not exceed 11dBm in any 1MHz band. | PASSED | 5.27 GHz = 8.67dBm 5.31 GHz = 6.67dBm <i>Per Original Filing</i> |
| 15.407(a)(2) | Peak transmit power and the peak power spectral density shall be reduced by the amount in dB that the transmitting antenna exceeds 6dBi. | N/A | All antennas tested have less than 6dBi antenna gain (Please see the antenna data sheets) |
| 15.407(b)(6) 15.209 | Unwanted emissions below 1 GHz must comply with the general field strength limits set forth in Section 15.209. | PASSED | <i>See Original Filing</i> |
| 15.407(b)(2) | All emissions outside of the 5.15-5.35 GHz band shall not exceed an EIRP of -27dBm/MHz. Must meet all applicable technical requirements for operating in the 5.15-5.25 GHz band. | PASSED | See Data Sheets |
| General Requirements For All Bands | | | |
| 15.407(a)(6) | The ratio of the peak excursion of the modulation envelope to the peak transmit power shall not exceed 13dB across any 1 MHz bandwidth or the emissions bandwidth whichever is less. | PASSED | 5.19 GHz = 4.83 dB 5.27 GHz = 4.33 dB 5.31 GHz = 5.34 dB <i>Per Original Filing</i> |
| 15.407(f) | Radio frequency radiation exposure requirement. | PASSED | Refer to MPE Calculations Exhibit |
| 15.407(b)(6) 15.207 | UNII devices using AC power line are required to comply with the conducted limits set forth in Section 15.207. | PASSED | <i>See Original Filing</i> |



2.0 Summary Of Test Results (Continued)

802.11n Mode 40MHz Wide (5150-5350 MHz) Chain B

| EMISSIONS STANDARD | | | |
|--|--|----------------|--|
| FCC Part 15 Section | Description | Results | Comments |
| Operation in the 5.15-5.25 GHz Band | | | |
| 15.407(d) | Any UNII device shall use a transmitting antenna that is an integral part of the device. | PASSED | The antenna will be integral when installed in a notebook computer |
| 15.407(e) | UNII devices will be restricted to indoor operations. | PASSED | Refer to "User's Manual" Exhibit |
| 15.407(a)(1) | 26dB emissions bandwidth in MHz. | N/A | 5.19 GHz = 40.30 MHz <i>Per Original Filing</i> |
| 15.407(a)(1) | Peak transmit power shall not exceed the lesser of 50mW or 4dBm+10logB (where B = 26dB emissions bandwidth). | PASSED | 5.19 GHz = 16.41dBm (43.74mW) |
| 15.407(a)(1) | The peak power spectral density shall not exceed 4dBm in any 1MHz band. | PASSED | 5.19 GHz = -22.27dBm <i>Per Original Filing</i> |
| 15.407(a)(1) | Peak transmit power and the peak power spectral density shall be reduced by the amount in dB that the transmitting antenna exceeds 6dBi. | N/A | All antennas tested have less than 6dBi antenna gain (Please see the antenna data sheets) |
| 15.407(b)(6) 15.209 | Unwanted emissions below 1 GHz must comply with the general field strength limits set forth in Section 15.209. | PASSED | <i>See Original Filing</i> |
| 15.407(b)(1) | All emissions outside of the 5.15-5.35 GHz band shall not exceed an EIRP of -27dBm/MHz. | PASSED | See Data Sheets |
| Operation in the 5.25-5.35 GHz Band | | | |
| 15.407(a)(2) | 26dB emissions bandwidth in MHz. | N/A | 5.27 GHz = 44.20 MHz 5.31 GHz = 39.70 MHz <i>Per Original Filing</i> |
| 15.407(a)(2) | Peak transmit power shall not exceed the lesser of 250mW or 11dBm+10logB (where B = 26dB emissions bandwidth). | PASSED | 5.27 GHz = 18.91dBm (77.79mW) 5.31 GHz = 16.21dBm (41.78mW) |
| 15.407(a)(2) | The peak power spectral density shall not exceed 11dBm in any 1MHz band. | PASSED | 5.27 GHz = 8.83dBm 5.31 GHz = 6.33dBm <i>Per Original Filing</i> |
| 15.407(a)(2) | Peak transmit power and the peak power spectral density shall be reduced by the amount in dB that the transmitting antenna exceeds 6dBi. | N/A | All antennas tested have less than 6dBi antenna gain (Please see the antenna data sheets) |
| 15.407(b)(6) 15.209 | Unwanted emissions below 1 GHz must comply with the general field strength limits set forth in Section 15.209. | PASSED | <i>See Original Filing</i> |
| 15.407(b)(2) | All emissions outside of the 5.15-5.35 GHz band shall not exceed an EIRP of -27dBm/MHz. Must meet all applicable technical requirements for operating in the 5.15-5.25 GHz band. | PASSED | See Data Sheets |
| General Requirements For All Bands | | | |
| 15.407(a)(6) | The ratio of the peak excursion of the modulation envelope to the peak transmit power shall not exceed 13dB across any 1 MHz bandwidth or the emissions bandwidth whichever is less. | PASSED | 5.19 GHz = 5.50 dB 5.27 GHz = 6.34 dB 5.31 GHz = 5.66 dB <i>Per Original Filing</i> |
| 15.407(f) | Radio frequency radiation exposure requirement. | PASSED | Refer to MPE Calculations Exhibit |
| 15.407(b)(6) 15.207 | UNII devices using AC power line are required to comply with the conducted limits set forth in Section 15.207. | PASSED | <i>See Original Filing</i> |



2.0 Summary Of Test Results (Continued)

ANALYSIS AND CONCLUSIONS

Based upon the measurement results we find that this equipment is within the limits of the global standards listed on the cover page of this test report. All results are based on a test of one sample. If any significant changes are made to the unit, the changes shall be evaluated and a retest may be required.

Approval Signatories

Test and Report Completed By:

04/02/07

Johnny Candelas
Test Technician
Aegis Labs, Inc.

Date:

Report Approved By:

04/02/07

Rick Candelas
Quality Assurance Manager
Aegis Labs, Inc.

Date:



3.0 ADMINISTRATIVE DATA AND TEST DESCRIPTION

| | |
|--------------------------------------|--|
| DEVICE TESTED: | ITE Type: Intel Wireless WiFi Link 4965AGN Model Number(s): 4965AGN Serial Number: 0013E804612B FCC ID: PD94965AGN |
| DATE EUT RECEIVED: | March 19 th , 2007 |
| TEST DATE(S): | March 20 th – 30 th , 2007 |
| ORIGIN OF TEST SAMPLE(S): | Production |
| EQUIPMENT CLASS: | EUT tested as CLASS B device |
| RESPONSIBLE PARTY: | Intel Corporation 2111 NE 25 th Avenue Hillsboro, Oregon 97124 |
| CLIENT CONTACT: | Mr. Robert Paxman |
| MANUFACTURER: | Intel Corporation |
| TEST LOCATION: | Aegis Labs, Inc. 32231 Trabuco Creek Road Trabuco Canyon, CA 92678 Open Area Test Site #1 |
| ACCREDITATION CERTIFICATE(S): | A2LA Certificate Number: 1111.01, Valid through February 28, 2008 |
| PURPOSE OF TEST: | To demonstrate compliance with the standards as described in Sections 1.0 & 2.0 of this report. |
| UNCERTAINTY BUDGET: | Proficiency Testing and Uncertainty Calculations for all tests indicated in this report have been conducted in accordance with ISO 17025: 2005 requirements Section 5.4.6, and 5.9. Uncertainty Budgets and Proficiency Test results available upon request. |
| STATEMENT OF CALIBRATION: | All accredited equipment calibrations were performed by Liberty Labs, Inc. and World Cal. with typical calibration uncertainty estimates derived from ISO Guide to the determination of uncertainties with a Coverage Factor of k=2 for 95% level of confidence. |

4.0 DESCRIPTION OF EUT CONFIGURATION

4.1 EUT Description

| Equipment Under Test (EUT) | |
|---|---|
| Trade Name: | Intel Wireless WiFi Link 4965AGN |
| Model Number: | 4965AGN |
| Frequency Range: | 802.11a = 5.15-5.35 GHz 802.11n = 5.15-5.35 GHz |
| Enclosure: | The EUT contains it's own shield made of aluminum approximately 2.5cm wide by 2cm deep by 2mm high. |
| Transfer Rate: | 6/36/54 Mbps for 802.11a mode Up to 300 Mbps for 802.11n mode |
| Antenna Type: | Monopole |
| Antenna Gain (See Note 2): | 1.62 dBi @ 5 GHz |
| Transmit Output Power: | Please see Appendix A (Data Sheets) for actual output power. |
| Power Supply: | 3.3VDC from computer MPCIE slot. |
| Number of External Test Ports Exercised: | 3 Antenna Ports |

The Intel Wireless WiFi Link 4965AGN is an embedded 802.11a/b/g/n network adapter operating in the 2.4 GHz and 5 GHz spectrum. The EUT is based on the Mini Card form factor designed to meet the space and size requirements for thin and light notebook PCs. It is capable of a data rate of up to 300 Mbps.

NOTE 1: For a more detailed description, please refer to the manufacture's specifications or User's Manual.

NOTE 2: The EUT was tested with a set of Sony IRIX-3980 Antennas. (Refer to the antenna specifications exhibits).



4.2 EUT Configuration

The EUT was tested installed in the Mini PCI-E slot of the host computer as a modular device using a PCI extender board to extend the EUT outside the computer chassis. The EUT was then connected to a set of antennas via its Chain A, B, & C antenna ports. Data for a set of Sony IRX-3980 Antennas can be found in Appendix A (Data Sheets)

The low, middle, and high channels were tested in 802.11a, b, g, & n modes. Also, the EUT was tested once transmitting from Chain A antenna port and once transmitting from Chain B antenna port. The EUT was placed in either continuous transmit or continuous receive mode by a program provided by the manufacturer (*CRTU Version 4.1.14.0000*).

4.3 List of EUT, Sub-Assemblies and Host Equipment

| Equipment Under Test | | | |
|-----------------------------|----------------------------------|-----------------------------|----------------------|
| Manufacturer | Equipment Name | Model or Part Number | Serial Number |
| Intel Corporation | Intel Wireless WiFi Link 4965AGN | 4965AGN | 0013E804612B |

| EUT Sub Assemblies | | | |
|---------------------------|-----------------------|-----------------------------|----------------------|
| Manufacturer | Equipment Name | Model or Part Number | Serial Number |
| Hitachi Cable, Ltd | Chain A (Tx) Antenna | 1-754-517 | N/A |
| Hitachi Cable, Ltd | Chain B (Tx) Antenna | 1-754-518 | N/A |
| Hitachi Cable, Ltd | Chain C (Rx) Antenna | 1-754-519 | N/A |

| HOST EQUIPMENT LIST | | | |
|----------------------------|-----------------------|-----------------------------|----------------------|
| Manufacturer | Equipment Name | Model or Part Number | Serial Number |
| GST | Host Computer | GST-8000 | G0400295337-015 |
| Sony | Monitor | CPD-200ES | 0742818 |
| Logitech | Keyboard | Y-BF37 | MCT25200581 |
| Logitech | Mouse | M-BJ58 | PMA32715049 |

NOTE: All the power cords of the above support equipment are standard and non-shielded.

4.4 I/O Cabling Diagram and Description

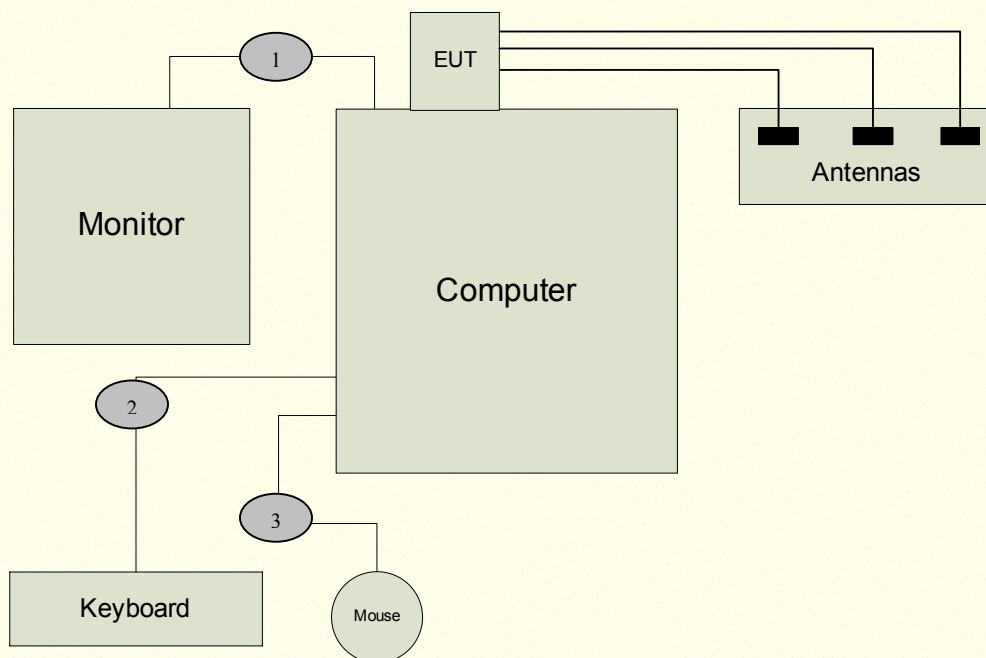

Signal Line Cable Description

| Cable | Length | Construction | Source Connector | Destination Connector | Bundled Length | Ferrite Attached | Note |
|-------|--------|------------------------------|--|------------------------|----------------|------------------|------|
| 1 | 1.5m | Round, Braid & Foil Shielded | Host Computer: Metallic DB-15 | Monitor: Hardwired | N/A | N/A | N/A |
| 2 | 1.5m | Round, Braid & Foil Shielded | Host Computer: Metallic 8-pin Mini DIN | Keyboard: Hardwired | N/A | N/A | N/A |
| 3 | 1.5m | Round, Braid & Foil Shielded | Host Computer: Metallic 8-pin Mini DIN | Mouse: Hardwired | N/A | N/A | N/A |



4.5 EMC Test Hardware and Software Measurement Equipment

TEST EQUIPMENT LIST - Emissions

| Equipment Name | Manufacturer | Model Number | Serial Number | Calibration Due Date | Maintenance Calibration Cycle |
|------------------------------|--------------------|-----------------|---------------|----------------------|-------------------------------|
| Spectrum Analyzer | Agilent | 8565EC | 3946A00245 | 07/24/07 | 1 Year |
| Antenna - Horn | EMCO | 3115 | 2230 | 05/15/07 | 1 Year |
| Preamp | Aegis | AEGIS-OATS-1-18 | 001 | 07/28/07 | 1 Year |
| 28 Foot Coax | Semflex | S1L29BFS1348 | 608 | 07/26/07 | 1 Year |
| 5.15-5.35 GHz Notch Filter | Microwave Circuits | N0452502 | 3173-01 | 04/21/07 | 2 Years |
| Power Meter | Anritsu | ML2487A | 6K00001785 | 05/30/07 | 1 Year |
| Wide Bandwidth Sensor | Anritsu | MA2491A | 31193 | 05/30/07 | 1 Year |
| 12dB Attenuator | Narda | 4779-12 | 203 | 06/09/07 | 2 Years |
| Temperature/Humidity Monitor | Dickson | TH550 | 7255185 | 03/24/08 | 2 Years |

5.0 CONDITIONS DURING EMISSIONS MEASUREMENTS

5.1 General

All measurements were made according to the procedures defined in or referred to by the standard listed on the cover page of this report. The measurements were made in the operating mode producing the largest emissions consistent with normal operation and connected to the minimum configuration of auxiliary devices.

5.2 Conducted Emissions Test Setup

The following was the test configuration.

EUT signal cables that hung closer than 40 cm to the horizontal metal ground plane were folded back and forth forming a bundle 30 cm to 40 cm long. The power cord of the EUT was also bundled in the center and plugged into one of the artificial mains network (AMN). All peripheral equipment was powered from a second AMN via a multiple outlet strip placed at a distance on 10cm from each other. The AMN and ISN were positioned 80cm from the EUT. Signal cables that were not connected to an AE were terminated using the correct termination. If applicable, the current probe was placed at 0.1 m from the ISN.

Peak, quasi-peak and/or average detectors were used for testing performed between 150 kHz and 30 MHz. A swept frequency scan was performed for both Line 1 and Line 2. The six highest readings were compared against the limit and recorded in the data sheet along with a snapshot image of the sweep scan. The graphical scans in Appendix A only reflect peak readings while the tabulated data sheets reflect peak, average, and/or quasi-peak measurements.

Climatic Conditions:

The EUT was tested within its intended operating and climatic conditions.

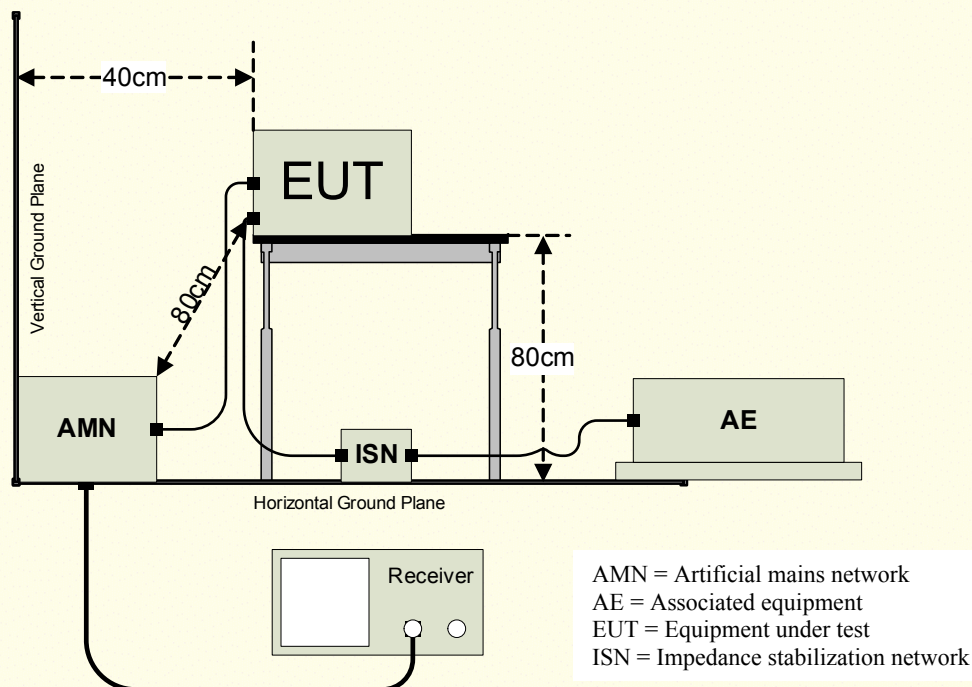

5.3 Radiated Emissions Test Setup

The Open Area Test Site (OATS) was used for radiated emission testing. The receiving (Rx) antenna(s) was placed 10m from the nearest side of the EUT facing the Rx antenna. The EUT (if floor-standing) was placed directly on the flush-mounted 360 degree rotating turntable. The EUT (if table-top) was placed directly on an 80cm high non-metallic table, and the table was placed on the rotating turntable. During the initial EMI scan, all the suspect frequencies, i.e.; harmonics, broadband signals were checked with the Rx broadband antennas in both vertical and horizontal polarities. The biconical Rx, log periodic Rx, and horn Rx antennas were used from 30MHz – 299.99MHz, 300MHz – 1000MHz, and 1GHz – 18GHz respectively.

Upon completion of all harmonic and broadband measurements, the balance of any remaining frequencies was checked between 30MHz – 18GHz. Any signals appearing within 20 dB of the classification limit was measured. Each signal was maximized by first rotating the turntable at least 360 degrees and recording the azimuth in the data sheet. Lastly, the Rx antenna was raised and/or lowered to maximize the signal elevation. If the measured signal was obtained using the peak detector and that signal appeared within 3 dB of the regulatory limit line, then the same signal was re-measured using the quasi-peak detector on the EMI receiver. Both meter readings if necessary were recorded on the data sheet.

Climatic Conditions:

The EUT was tested within its intended operating and climatic conditions.

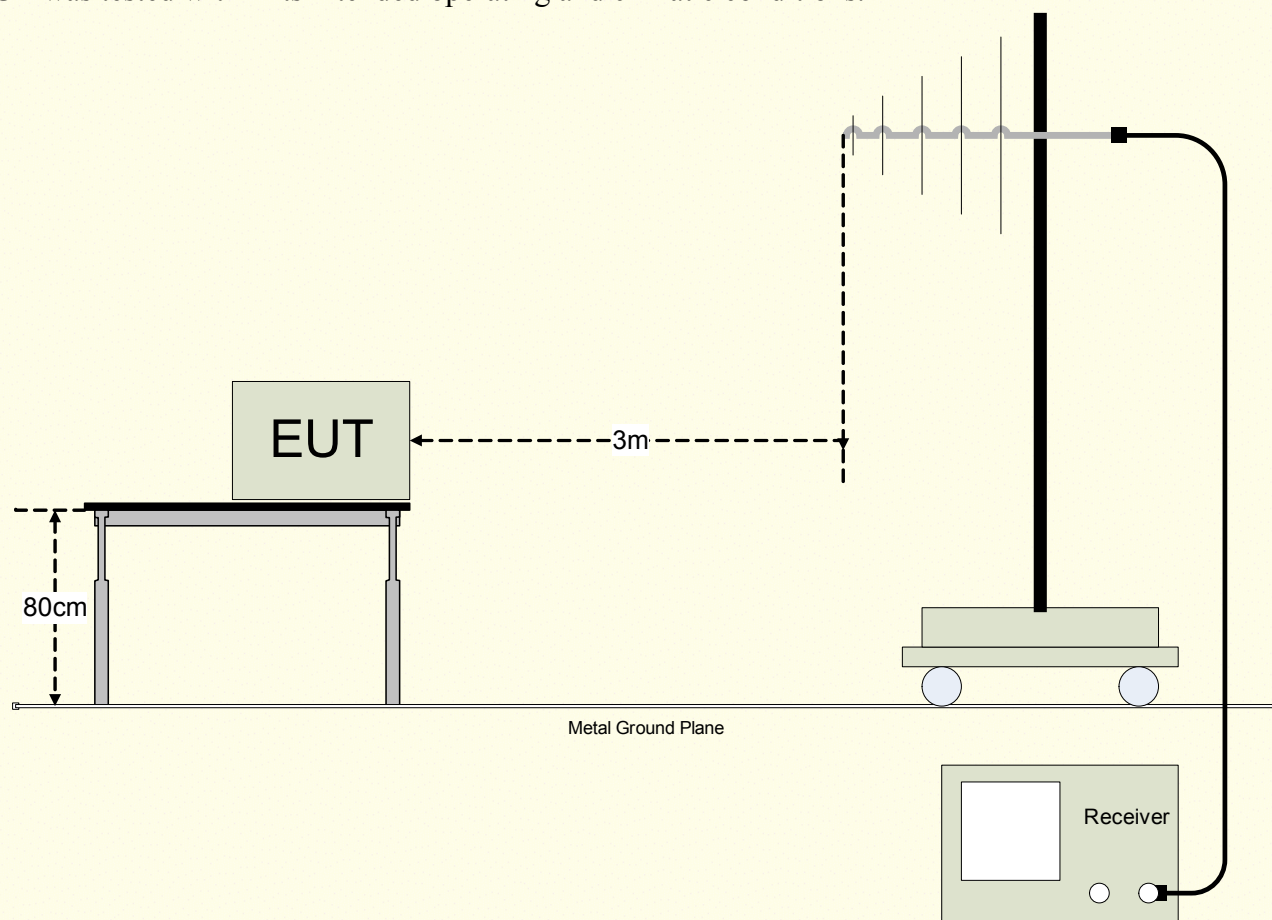



APPENDIX A

TEST DATA



RADIATED EMISSIONS TEST RESULTS

| | | | |
|-----------------------|--|----------------------------|--------------|
| CLIENT: | Intel Corporation | DATE: | 03/20/07 |
| EUT: | Intel Wireless WiFi Link 4965AGN | PROJECT NUMBER: | INTEL-070320 |
| MODEL NUMBER: | 4965AGN | TEST ENGINEER: | BM/JC |
| SERIAL NUMBER: | 0013E804612B | SITE #: | 1 |
| CONFIGURATION: | Tested installed in the host computer's mini PCI slot in 802.11a (5150-5350 MHz) mode with Sony IRX-3980 Antennas. | TEMPERATURE: | 15 deg. C |
| | | HUMIDITY: | 52% RH |
| | | TIME: | 5:30 PM |

| | |
|---------------------|---|
| Description: | Radiated RF Emissions (1 GHz – 18 GHz) |
| Results: | PASSED Horizontal and Vertical Antenna Polarizations Class B Limits |
| Note: | Radiated Emissions Measurements were performed on the EUT with power supply set at the following voltage and frequency. <ul style="list-style-type: none"> • 120VAC / 60 Hz. |

| Unwanted Spurious Emissions Limits | | | |
|------------------------------------|-----------------------|--|--|
| Frequency (MHz) | Field Strength (uV/m) | Field Strength (dBuV/m) (Emissions in the restricted bands) | Field Strength (dBm/MHz) (Emissions outside the restricted bands) |
| Above 960 | 500 | 54.00 (Average) 74.00 (Peak) | < -20 dBc |

Radiated Emissions Sample Calculations

$$\text{Corrected Meter Reading} = \text{Meter Reading} + F + C - D$$

Where, F = Antenna Factor

C = Cable Factor

G = Amplifier Gain

D = Distance Factor (if applicable)

Therefore, the equation for determining the Corrected Meter Reading Limit (CML) is:

$$\text{CML} = \text{Specification Limit} - F - C + D$$



Radiated Emissions Test Results (Continued)

*Fundamental Measurements in 802.11a mode (5150-5350 MHz)
 Channels 36, 48, 52, & 64
 Continuous TX at Chain A Antenna port with Sony IRX-3980 Antennas
 Aegis Labs, Inc. File #: INTEL-070320-02*

| RADIATED EMISSIONS - Horizontal Antenna Polarization | | | | | | | | | | | | |
|---|----------------------|---------------------|-------------------|------------------------|---|----------------------|-------------------|------------------|--------------------------|---------------|------------------|---------------|
| Freq. (MHz) | Meter Reading (dBuV) | Antenna Height (cm) | Azimuth (degrees) | Quasi pk or AVG (dBuV) | | Distance Factor (dB) | Cable Factor (dB) | Ant. Factor (dB) | Corrected Reading (dBuV) | Limits (dBuV) | Diff (dB) +=FAIL | Comments |
| 5180.00 | 63.67 | 100 | 225 | | | 9.54 | 2.98 | 34.62 | 91.73 | | | Ch. 36 |
| 5180.00 | | | | 51.33 | A | 9.54 | 2.98 | 34.62 | 79.39 | | | |
| 5240.00 | 64.83 | 100 | 225 | | | 9.54 | 3.00 | 34.73 | 93.02 | | | Ch. 48 |
| 5240.00 | | | | 51.17 | A | 9.54 | 3.00 | 34.73 | 79.36 | | | |
| 5260.00 | 65.17 | 100 | 225 | | | 9.54 | 3.00 | 34.77 | 93.40 | | | Ch. 52 |
| 5260.00 | | | | 51.17 | A | 9.54 | 3.00 | 34.77 | 79.40 | | | |
| 5320.00 | 62.17 | 100 | 225 | | | 9.54 | 3.02 | 34.88 | 90.53 | | | Ch. 64 |
| 5320.00 | | | | 50.17 | A | 9.54 | 3.02 | 34.88 | 78.53 | | | |

| RADIATED EMISSIONS - Vertical Antenna Polarization | | | | | | | | | | | | |
|---|----------------------|---------------------|-------------------|------------------------|---|----------------------|-------------------|------------------|--------------------------|---------------|------------------|---------------|
| Freq. (MHz) | Meter Reading (dBuV) | Antenna Height (cm) | Azimuth (degrees) | Quasi pk or AVG (dBuV) | | Distance Factor (dB) | Cable Factor (dB) | Ant. Factor (dB) | Corrected Reading (dBuV) | Limits (dBuV) | Diff (dB) +=FAIL | Comments |
| 5180.00 | 60.33 | 100 | 180 | | | 9.54 | 2.98 | 34.39 | 88.16 | | | Ch. 36 |
| 5180.00 | | | | 46.83 | A | 9.54 | 2.98 | 34.39 | 74.66 | | | |
| 5240.00 | 63.00 | 100 | 225 | | | 9.54 | 3.00 | 34.48 | 90.94 | | | Ch. 48 |
| 5240.00 | | | | 49.00 | A | 9.54 | 3.00 | 34.48 | 76.94 | | | |
| 5260.00 | 62.33 | 100 | 225 | | | 9.54 | 3.00 | 34.52 | 90.31 | | | Ch. 52 |
| 5260.00 | | | | 48.67 | A | 9.54 | 3.00 | 34.52 | 76.65 | | | |
| 5320.00 | 60.17 | 100 | 225 | | | 9.54 | 3.02 | 34.61 | 88.26 | | | Ch. 64 |
| 5320.00 | | | | 48.50 | A | 9.54 | 3.02 | 34.61 | 76.59 | | | |

NOTE: Fundamental signals measured at 1 meter and extrapolated to 3 meters to calculate the radiated band edge field strengths.



Radiated Emissions Test Results (Continued)

*Band Edge Field Strength Measurements in 802.11a mode (5150-5350 MHz)
 Channels 36 & 64
 Continuous TX at Chain A Antenna port with Sony IRX-3980 Antennas
 Aegis Labs, Inc. File #: INTEL-070320-02*

| RADIATED EMISSIONS - Horizontal Antenna Polarization | | | | | | | | | | | | |
|---|----------------------|---------------------|-------------------|------------------------|---|----------------------|-------------------|------------------|--------------------------|---------------|------------------|---------------|
| Freq. (MHz) | Meter Reading (dBuV) | Antenna Height (cm) | Azimuth (degrees) | Quasi pk or AVG (dBuV) | | Distance Factor (dB) | Cable Factor (dB) | Ant. Factor (dB) | Corrected Reading (dBuV) | Limits (dBuV) | Diff (dB) +=FAIL | Comments |
| 5150.00 | 30.33 | 100 | 225 | | | 9.54 | 2.97 | 34.57 | 58.33 | 74.00 | -15.67 | Ch. 36 |
| 5150.00 | | | | 18.33 | A | 9.54 | 2.97 | 34.57 | 46.33 | 54.00 | -7.67 | |
| 5350.00 | 30.33 | 100 | 225 | | | 9.54 | 3.03 | 34.93 | 58.75 | 74.00 | -15.25 | Ch. 64 |
| 5350.00 | | | | 18.67 | A | 9.54 | 3.03 | 34.93 | 47.09 | 54.00 | -6.91 | |

| RADIATED EMISSIONS - Vertical Antenna Polarization | | | | | | | | | | | | |
|---|----------------------|---------------------|-------------------|------------------------|---|----------------------|-------------------|------------------|--------------------------|---------------|------------------|---------------|
| Freq. (MHz) | Meter Reading (dBuV) | Antenna Height (cm) | Azimuth (degrees) | Quasi pk or AVG (dBuV) | | Distance Factor (dB) | Cable Factor (dB) | Ant. Factor (dB) | Corrected Reading (dBuV) | Limits (dBuV) | Diff (dB) +=FAIL | Comments |
| 5150.00 | 30.00 | 100 | 180 | | | 9.54 | 2.97 | 34.34 | 57.77 | 74.00 | -16.23 | Ch. 36 |
| 5150.00 | | | | 18.17 | A | 9.54 | 2.97 | 34.34 | 45.94 | 54.00 | -8.06 | |
| 5350.00 | 30.17 | 100 | 225 | | | 9.54 | 3.03 | 34.66 | 58.32 | 74.00 | -15.68 | Ch. 64 |
| 5350.00 | | | | 18.67 | A | 9.54 | 3.03 | 34.66 | 46.82 | 54.00 | -7.18 | |

NOTE: The "Band Edge Field Strength" was calculated using the "Radiated Fundamental" measurements.



Radiated Emissions Test Results (Continued)

*Spurious Emissions Measurements in 802.11a mode (5150-5350 MHz)
 Channels 36, 52, & 64
 Continuous TX at Chain A Antenna port with Sony IRX-3980 Antennas
 Aegis Labs, Inc. File #: INTEL-070320-07*

RADIATED EMISSIONS - Horizontal Antenna Polarization

| Freq. (MHz) | Meter Reading (dBuV) | Antenna Height (cm) | Azimuth (degrees) | Quasi pk or AVG (dBuV) | Preamp Factor (dB) | Cable Factor (dB) | Ant. Factor (dB) | Corrected Reading (dBuV) | Limits (dBuV) | Diff (dB) +=FAIL | Comments |
|-------------|----------------------|---------------------|-------------------|------------------------|--------------------|-------------------|------------------|--------------------------|---------------|------------------|---------------|
| 3453.33 | 66.50 | 100 | 225 | | 50.78 | 2.41 | 32.29 | 50.42 | 68.00 | -17.58 | Ch. 36 |
| 6906.66 | 66.67 | 100 | 225 | | 50.50 | 3.47 | 35.91 | 55.54 | 68.00 | -12.46 | |
| 3506.66 | 65.67 | 100 | 225 | | 50.76 | 2.43 | 32.41 | 49.76 | 68.00 | -18.24 | Ch. 52 |
| 7013.40 | 67.17 | 100 | 135 | | 50.42 | 3.51 | 36.03 | 56.29 | 68.00 | -11.71 | |
| 3546.66 | 65.33 | 100 | 180 | | 50.76 | 2.45 | 32.50 | 49.52 | 68.00 | -18.48 | Ch.64 |
| 7093.34 | 63.50 | 100 | 180 | | 50.38 | 3.53 | 36.24 | 52.89 | 68.00 | -15.11 | |

RADIATED EMISSIONS - Vertical Antenna Polarization

| Freq. (MHz) | Meter Reading (dBuV) | Antenna Height (cm) | Azimuth (degrees) | Quasi pk or AVG (dBuV) | Preamp Factor (dB) | Cable Factor (dB) | Ant. Factor (dB) | Corrected Reading (dBuV) | Limits (dBuV) | Diff (dB) +=FAIL | Comments |
|-------------|----------------------|---------------------|-------------------|------------------------|--------------------|-------------------|------------------|--------------------------|---------------|------------------|---------------|
| 3453.33 | 68.50 | 100 | 180 | | 50.78 | 2.41 | 31.80 | 51.93 | 68.00 | -16.07 | Ch. 36 |
| 6906.66 | 68.33 | 100 | 90 | | 50.50 | 3.47 | 35.83 | 57.12 | 68.00 | -10.88 | |
| 10360.00 | 66.33 | 100 | 180 | | 50.39 | 4.39 | 38.59 | 58.92 | 68.00 | -9.08 | |
| 3506.16 | 68.50 | 100 | 135 | | 50.76 | 2.43 | 31.92 | 52.09 | 68.00 | -15.91 | Ch. 52 |
| 7013.39 | 67.67 | 100 | 135 | | 50.42 | 3.51 | 35.93 | 56.69 | 68.00 | -11.31 | |
| 3546.68 | 67.33 | 100 | 180 | | 50.76 | 2.45 | 32.02 | 51.04 | 68.00 | -16.96 | Ch.64 |
| 7093.55 | 65.33 | 100 | 180 | | 50.38 | 3.53 | 36.14 | 54.62 | 68.00 | -13.38 | |



Radiated Emissions Test Results (Continued)

*Spurious Emissions Measurements in 802.11a mode (5150-5350 MHz)
 Channels 36, 52, & 64
 Continuous RX at Chain A Antenna port with Sony IRX-3980 Antennas
 Aegis Labs, Inc. File #: INTEL-070320-07*

RADIATED EMISSIONS - Horizontal Antenna Polarization

| Freq. (MHz) | Meter Reading (dBuV) | Antenna Height (cm) | Azimuth (degrees) | Quasi pk or AVG (dBuV) | | Preamp Factor (dB) | Cable Factor (dB) | Ant. Factor (dB) | Corrected Reading (dBuV) | Limits (dBuV) | Diff (dB) +=FAIL | Comments |
|-------------|----------------------|---------------------|-------------------|------------------------|---|--------------------|-------------------|------------------|--------------------------|---------------|------------------|---------------|
| 3453.33 | 64.17 | 125 | 225 | | | 50.78 | 2.41 | 32.29 | 48.09 | 74.00 | -25.91 | Ch. 36 |
| 3453.33 | | | | 54.73 | A | 50.78 | 2.41 | 32.29 | 38.65 | 54.00 | -15.35 | |
| 3506.66 | 63.83 | 100 | 225 | | | 50.76 | 2.43 | 32.41 | 47.92 | 74.00 | -26.08 | Ch. 52 |
| 3506.66 | | | | 54.75 | A | 50.76 | 2.43 | 32.41 | 38.84 | 54.00 | -15.16 | |
| 3546.66 | 63.17 | 100 | 225 | | | 50.76 | 2.45 | 32.50 | 47.36 | 74.00 | -26.64 | Ch.64 |
| 3546.66 | | | | 53.12 | A | 50.76 | 2.45 | 32.50 | 37.31 | 54.00 | -16.69 | |

RADIATED EMISSIONS - Vertical Antenna Polarization

| Freq. (MHz) | Meter Reading (dBuV) | Antenna Height (cm) | Azimuth (degrees) | Quasi pk or AVG (dBuV) | | Preamp Factor (dB) | Cable Factor (dB) | Ant. Factor (dB) | Corrected Reading (dBuV) | Limits (dBuV) | Diff (dB) +=FAIL | Comments |
|-------------|----------------------|---------------------|-------------------|------------------------|---|--------------------|-------------------|------------------|--------------------------|---------------|------------------|---------------|
| 3453.33 | 66.00 | 100 | 225 | | | 50.78 | 2.41 | 31.80 | 49.43 | 74.00 | -24.57 | Ch. 36 |
| 3453.33 | | | | 56.78 | A | 50.78 | 2.41 | 31.80 | 40.21 | 54.00 | -13.79 | |
| 3506.68 | 62.67 | 100 | 225 | | | 50.76 | 2.43 | 31.92 | 46.26 | 74.00 | -27.74 | Ch. 52 |
| 3506.68 | | | | 52.06 | A | 50.76 | 2.43 | 31.92 | 35.65 | 54.00 | -18.35 | |
| 3546.66 | 63.00 | 100 | 225 | | | 50.76 | 2.45 | 32.02 | 46.71 | 74.00 | -27.29 | Ch.64 |
| 3546.66 | | | | 51.81 | A | 50.76 | 2.45 | 32.02 | 35.52 | 54.00 | -18.48 | |



Radiated Emissions Test Results (Continued)

Fundamental Measurements in 802.11a mode (5150-5350 MHz)
Channels 36, 48, 52, & 64
Continuous TX at Chain B Antenna port with Sony IRX-3980 Antennas
Aegis Labs, Inc. File #: INTEL-070320-03

| RADIATED EMISSIONS - Horizontal Antenna Polarization | | | | | | | | | | | | |
|---|----------------------|---------------------|-------------------|------------------------|---|----------------------|-------------------|------------------|--------------------------|---------------|------------------|---------------|
| Freq. (MHz) | Meter Reading (dBuV) | Antenna Height (cm) | Azimuth (degrees) | Quasi pk or AVG (dBuV) | | Distance Factor (dB) | Cable Factor (dB) | Ant. Factor (dB) | Corrected Reading (dBuV) | Limits (dBuV) | Diff (dB) +=FAIL | Comments |
| 5180.00 | 75.50 | 100 | 225 | | | 9.54 | 2.98 | 34.62 | 103.56 | | | Ch. 36 |
| 5180.00 | | | | 60.33 | A | 9.54 | 2.98 | 34.62 | 88.39 | | | |
| 5240.00 | 77.17 | 100 | 225 | | | 9.54 | 3.00 | 34.73 | 105.36 | | | Ch. 48 |
| 5240.00 | | | | 62.17 | A | 9.54 | 3.00 | 34.73 | 90.36 | | | |
| 5260.00 | 79.33 | 100 | 225 | | | 9.54 | 3.00 | 34.77 | 107.56 | | | Ch. 52 |
| 5260.00 | | | | 64.33 | A | 9.54 | 3.00 | 34.77 | 92.56 | | | |
| 5320.00 | 76.33 | 100 | 225 | | | 9.54 | 3.02 | 34.88 | 104.69 | | | Ch. 64 |
| 5320.00 | | | | 61.33 | A | 9.54 | 3.02 | 34.88 | 89.69 | | | |

| RADIATED EMISSIONS - Vertical Antenna Polarization | | | | | | | | | | | | |
|---|----------------------|---------------------|-------------------|------------------------|---|----------------------|-------------------|------------------|--------------------------|---------------|------------------|---------------|
| Freq. (MHz) | Meter Reading (dBuV) | Antenna Height (cm) | Azimuth (degrees) | Quasi pk or AVG (dBuV) | | Distance Factor (dB) | Cable Factor (dB) | Ant. Factor (dB) | Corrected Reading (dBuV) | Limits (dBuV) | Diff (dB) +=FAIL | Comments |
| 5180.00 | 72.83 | 100 | 225 | | | 9.54 | 2.98 | 34.39 | 100.66 | | | Ch. 36 |
| 5180.00 | | | | 58.17 | A | 9.54 | 2.98 | 34.39 | 86.00 | | | |
| 5240.00 | 73.17 | 100 | 225 | | | 9.54 | 3.00 | 34.48 | 101.11 | | | Ch. 48 |
| 5240.00 | | | | 58.50 | A | 9.54 | 3.00 | 34.48 | 86.44 | | | |
| 5260.00 | 74.50 | 100 | 225 | | | 9.54 | 3.00 | 34.52 | 102.48 | | | Ch. 52 |
| 5260.00 | | | | 60.17 | A | 9.54 | 3.00 | 34.52 | 88.15 | | | |
| 5320.00 | 72.00 | 100 | 135 | | | 9.54 | 3.02 | 34.61 | 100.09 | | | Ch. 64 |
| 5320.00 | | | | 58.33 | A | 9.54 | 3.02 | 34.61 | 86.42 | | | |

NOTE: Fundamental signals measured at 1 meter and extrapolated to 3 meters to calculate the radiated band edge field strengths.



Radiated Emissions Test Results (Continued)

*Band Edge Field Strength Measurements in 802.11a mode (5150-5350 MHz)
 Channels 36 & 64
 Continuous TX at Chain B Antenna port with Sony IRX-3980 Antennas
 Aegis Labs, Inc. File #: INTEL-070320-03*

| RADIATED EMISSIONS - Horizontal Antenna Polarization | | | | | | | | | | | | |
|---|----------------------|---------------------|-------------------|------------------------|---|----------------------|-------------------|------------------|--------------------------|---------------|------------------|---------------|
| Freq. (MHz) | Meter Reading (dBuV) | Antenna Height (cm) | Azimuth (degrees) | Quasi pk or AVG (dBuV) | | Distance Factor (dB) | Cable Factor (dB) | Ant. Factor (dB) | Corrected Reading (dBuV) | Limits (dBuV) | Diff (dB) +=FAIL | Comments |
| 5150.00 | 31.67 | 100 | 225 | | | 9.54 | 2.97 | 34.57 | 59.67 | 74.00 | -14.33 | Ch. 36 |
| 5150.00 | | | | 19.17 | A | 9.54 | 2.97 | 34.57 | 47.17 | 54.00 | -6.83 | |
| 5350.00 | 32.33 | 100 | 225 | | | 9.54 | 3.03 | 34.93 | 60.75 | 74.00 | -13.25 | Ch. 64 |
| 5350.00 | | | | 20.00 | A | 9.54 | 3.03 | 34.93 | 48.42 | 54.00 | -5.58 | |

| RADIATED EMISSIONS - Vertical Antenna Polarization | | | | | | | | | | | | |
|---|----------------------|---------------------|-------------------|------------------------|---|----------------------|-------------------|------------------|--------------------------|---------------|------------------|---------------|
| Freq. (MHz) | Meter Reading (dBuV) | Antenna Height (cm) | Azimuth (degrees) | Quasi pk or AVG (dBuV) | | Distance Factor (dB) | Cable Factor (dB) | Ant. Factor (dB) | Corrected Reading (dBuV) | Limits (dBuV) | Diff (dB) +=FAIL | Comments |
| 5150.00 | 30.67 | 100 | 225 | | | 9.54 | 2.97 | 34.34 | 58.44 | 74.00 | -15.56 | Ch. 36 |
| 5150.00 | | | | 19.00 | A | 9.54 | 2.97 | 34.34 | 46.77 | 54.00 | -7.23 | |
| 5350.00 | 30.17 | 100 | 135 | | | 9.54 | 3.03 | 34.66 | 58.32 | 74.00 | -15.68 | Ch. 64 |
| 5350.00 | | | | 19.00 | A | 9.54 | 3.03 | 34.66 | 47.15 | 54.00 | -6.85 | |

NOTE: The “Band Edge Field Strength” was calculated using the “Radiated Fundamental” measurements.



Radiated Emissions Test Results (Continued)

*Spurious Emissions Measurements in 802.11a mode (5150-5350 MHz)
 Channels 36, 52, & 64
 Continuous TX at Chain B Antenna port with Sony IRX-3980 Antennas
 Aegis Labs, Inc. File #: INTEL-070320-08*

RADIATED EMISSIONS - Horizontal Antenna Polarization

| Freq. (MHz) | Meter Reading (dBuV) | Antenna Height (cm) | Azimuth (degrees) | Quasi pk or AVG (dBuV) | Preamp Factor (dB) | Cable Factor (dB) | Ant. Factor (dB) | Corrected Reading (dBuV) | Limits (dBuV) | Diff (dB) +=FAIL | Comments |
|-------------|----------------------|---------------------|-------------------|------------------------|--------------------|-------------------|------------------|--------------------------|---------------|------------------|---------------|
| 3453.33 | 59.83 | 100 | 225 | | 50.78 | 2.41 | 32.29 | 43.75 | 68.00 | -24.25 | Ch. 36 |
| 6906.66 | 58.33 | 125 | 225 | | 50.50 | 3.47 | 35.91 | 47.20 | 68.00 | -20.80 | |
| 10360.00 | 67.17 | 100 | 225 | | 50.39 | 4.39 | 38.62 | 59.79 | 68.00 | -8.21 | |
| 3506.66 | 59.33 | 100 | 225 | | 50.76 | 2.43 | 32.41 | 43.42 | 68.00 | -24.58 | Ch. 52 |
| 7013.40 | 57.67 | 100 | 180 | | 50.42 | 3.51 | 36.03 | 46.79 | 68.00 | -21.21 | |
| 10520.00 | 64.33 | 100 | 135 | | 50.43 | 4.44 | 38.71 | 57.05 | 68.00 | -10.95 | |
| 3546.66 | 58.83 | 100 | 225 | | 50.76 | 2.45 | 32.50 | 43.02 | 68.00 | -24.98 | Ch.64 |
| 7093.34 | 56.00 | 100 | 180 | | 50.38 | 3.53 | 36.24 | 45.39 | 68.00 | -22.61 | |
| 10640.00 | 67.67 | 100 | 225 | | 50.44 | 4.46 | 38.76 | 60.45 | 74.00 | -13.55 | |
| 10640.00 | | | | 53.50 A | 50.44 | 4.46 | 38.76 | 46.28 | 54.00 | -7.72 | |

RADIATED EMISSIONS - Vertical Antenna Polarization

| Freq. (MHz) | Meter Reading (dBuV) | Antenna Height (cm) | Azimuth (degrees) | Quasi pk or AVG (dBuV) | Preamp Factor (dB) | Cable Factor (dB) | Ant. Factor (dB) | Corrected Reading (dBuV) | Limits (dBuV) | Diff (dB) +=FAIL | Comments |
|-------------|----------------------|---------------------|-------------------|------------------------|--------------------|-------------------|------------------|--------------------------|---------------|------------------|---------------|
| 3453.33 | 58.08 | 100 | 180 | | 50.78 | 2.41 | 31.80 | 41.51 | 68.00 | -26.49 | Ch. 36 |
| 6906.66 | 59.50 | 100 | 180 | | 50.50 | 3.47 | 35.83 | 48.29 | 68.00 | -19.71 | |
| 10360.00 | 68.67 | 100 | 180 | | 50.39 | 4.39 | 38.59 | 61.26 | 68.00 | -6.74 | |
| 3506.16 | 58.67 | 100 | 180 | | 50.76 | 2.43 | 31.92 | 42.26 | 68.00 | -25.74 | Ch. 52 |
| 7013.39 | 58.33 | 100 | 180 | | 50.42 | 3.51 | 35.93 | 47.35 | 68.00 | -20.65 | |
| 10520.00 | 67.67 | 100 | 180 | | 50.43 | 4.44 | 38.70 | 60.39 | 68.00 | -7.61 | |
| 3546.68 | 58.50 | 100 | 180 | | 50.76 | 2.45 | 32.02 | 42.21 | 68.00 | -25.79 | Ch.64 |
| 7093.55 | 57.33 | 100 | 180 | | 50.38 | 3.53 | 36.14 | 46.62 | 68.00 | -21.38 | |
| 10640.00 | 69.83 | 100 | 180 | | 50.44 | 4.46 | 38.73 | 62.58 | 74.00 | -11.42 | |
| 10640.00 | | | | 56.44 A | 50.44 | 4.46 | 38.73 | 49.19 | 54.00 | -4.81 | |



Radiated Emissions Test Results (Continued)

*Spurious Emissions Measurements in 802.11a mode (5150-5350 MHz)
Channels 36, 52, & 64
Continuous RX at Chain B Antenna port with Sony IRX-3980 Antennas
Aegis Labs, Inc. File #: INTEL-070320-08*

RADIATED EMISSIONS - Horizontal Antenna Polarization

| Freq. (MHz) | Meter Reading (dBuV) | Antenna Height (cm) | Azimuth (degrees) | Quasi pk or AVG (dBuV) | | Preamp Factor (dB) | Cable Factor (dB) | Ant. Factor (dB) | Corrected Reading (dBuV) | Limits (dBuV) | Diff (dB) +=FAIL | Comments |
|-------------|----------------------|---------------------|-------------------|------------------------|---|--------------------|-------------------|------------------|--------------------------|---------------|------------------|---------------|
| 3453.33 | 54.17 | 125 | 225 | | | 50.78 | 2.41 | 32.29 | 38.09 | 74.00 | -35.91 | Ch. 36 |
| 3453.33 | | | | 44.73 | A | 50.78 | 2.41 | 32.29 | 28.65 | 54.00 | -25.35 | |
| 3506.66 | 53.83 | 100 | 225 | | | 50.76 | 2.43 | 32.41 | 37.92 | 74.00 | -36.08 | Ch. 52 |
| 3506.66 | | | | 44.75 | A | 50.76 | 2.43 | 32.41 | 28.84 | 54.00 | -25.16 | |
| 3546.66 | 53.17 | 100 | 225 | | | 50.76 | 2.45 | 32.50 | 37.36 | 74.00 | -36.64 | Ch.64 |
| 3546.66 | | | | 43.12 | A | 50.76 | 2.45 | 32.50 | 27.31 | 54.00 | -26.69 | |

RADIATED EMISSIONS - Vertical Antenna Polarization

| Freq. (MHz) | Meter Reading (dBuV) | Antenna Height (cm) | Azimuth (degrees) | Quasi pk or AVG (dBuV) | | Preamp Factor (dB) | Cable Factor (dB) | Ant. Factor (dB) | Corrected Reading (dBuV) | Limits (dBuV) | Diff (dB) +=FAIL | Comments |
|-------------|----------------------|---------------------|-------------------|------------------------|---|--------------------|-------------------|------------------|--------------------------|---------------|------------------|---------------|
| 3453.33 | 56.00 | 100 | 225 | | | 50.78 | 2.41 | 31.80 | 39.43 | 74.00 | -34.57 | Ch. 36 |
| 3453.33 | | | | 46.78 | A | 50.78 | 2.41 | 31.80 | 30.21 | 54.00 | -23.79 | |
| 3506.68 | 52.67 | 100 | 225 | | | 50.76 | 2.43 | 31.92 | 36.26 | 74.00 | -37.74 | Ch. 52 |
| 3506.68 | | | | 42.06 | A | 50.76 | 2.43 | 31.92 | 25.65 | 54.00 | -28.35 | |
| 3546.66 | 53.00 | 100 | 225 | | | 50.76 | 2.45 | 32.02 | 36.71 | 74.00 | -37.29 | Ch.64 |
| 3546.66 | | | | 41.81 | A | 50.76 | 2.45 | 32.02 | 25.52 | 54.00 | -28.48 | |



RADIATED EMISSIONS TEST RESULTS

| | | | |
|-----------------------|--|----------------------------|--------------|
| CLIENT: | Intel Corporation | DATE: | 03/21/07 |
| EUT: | Intel Wireless WiFi Link 4965AGN | PROJECT NUMBER: | INTEL-070320 |
| MODEL NUMBER: | 4965AGN | TEST ENGINEER: | BM/JC |
| SERIAL NUMBER: | 0013E804612B | SITE #: | 1 |
| CONFIGURATION: | Tested installed in the host computer's mini PCI slot in 802.11n (5150-5350 MHz) mode 20MHz Wide with Sony IRX-3980 Antennas. | TEMPERATURE: | 10 deg. C |
| | | HUMIDITY: | 62% RH |
| | | TIME: | 7:00 PM |

| | |
|---------------------|---|
| Description: | Radiated RF Emissions (1 GHz – 18 GHz) |
| Results: | PASSED Horizontal and Vertical Antenna Polarizations Class B Limits |
| Note: | Radiated Emissions Measurements were performed on the EUT with power supply set at the following voltage and frequency. <ul style="list-style-type: none"> 120VAC / 60 Hz. |

| Unwanted Spurious Emissions Limits | | | |
|------------------------------------|-----------------------|--|--|
| Frequency (MHz) | Field Strength (uV/m) | Field Strength (dBuV/m) (Emissions in the restricted bands) | Field Strength (dBm/MHz) (Emissions outside the restricted bands) |
| Above 960 | 500 | 54.00 (Average) 74.00 (Peak) | < -20 dBc |

Radiated Emissions Sample Calculations

$$\text{Corrected Meter Reading} = \text{Meter Reading} + F + C - D$$

Where, F = Antenna Factor

C = Cable Factor

G = Amplifier Gain

D = Distance Factor (if applicable)

Therefore, the equation for determining the Corrected Meter Reading Limit (CML) is:

$$\text{CML} = \text{Specification Limit} - F - C + D$$



Radiated Emissions Test Results (Continued)

*Fundamental Measurements in 802.11n mode 20MHz Wide (5150-5350 MHz)
 Channels 36, 48, 52, & 64
 Continuous TX at Chain A Antenna port with Sony IRX-3980 Antennas
 Aegis Labs, Inc. File #: INTEL-070320-04*

| RADIATED EMISSIONS - Horizontal Antenna Polarization | | | | | | | | | | | | |
|---|----------------------|---------------------|-------------------|------------------------|---|----------------------|-------------------|------------------|--------------------------|---------------|------------------|---------------|
| Freq. (MHz) | Meter Reading (dBuV) | Antenna Height (cm) | Azimuth (degrees) | Quasi pk or AVG (dBuV) | | Distance Factor (dB) | Cable Factor (dB) | Ant. Factor (dB) | Corrected Reading (dBuV) | Limits (dBuV) | Diff (dB) +=FAIL | Comments |
| 5180.00 | 62.17 | 100 | 225 | | | 9.54 | 2.98 | 34.62 | 90.23 | | | Ch. 36 |
| 5180.00 | | | | 49.00 | A | 9.54 | 2.98 | 34.62 | 77.06 | | | |
| 5240.00 | 74.17 | 125 | 225 | | | 9.54 | 3.00 | 34.73 | 102.36 | | | Ch. 48 |
| 5240.00 | | | | 59.17 | A | 9.54 | 3.00 | 34.73 | 87.36 | | | |
| 5260.00 | 77.00 | 100 | 225 | | | 9.54 | 3.00 | 34.77 | 105.23 | | | Ch. 52 |
| 5260.00 | | | | 61.83 | A | 9.54 | 3.00 | 34.77 | 90.06 | | | |
| 5320.00 | 65.50 | 100 | 225 | | | 9.54 | 3.02 | 34.88 | 93.86 | | | Ch. 64 |
| 5320.00 | | | | 50.50 | A | 9.54 | 3.02 | 34.88 | 78.86 | | | |

| RADIATED EMISSIONS - Vertical Antenna Polarization | | | | | | | | | | | | |
|---|----------------------|---------------------|-------------------|------------------------|---|----------------------|-------------------|------------------|--------------------------|---------------|------------------|---------------|
| Freq. (MHz) | Meter Reading (dBuV) | Antenna Height (cm) | Azimuth (degrees) | Quasi pk or AVG (dBuV) | | Distance Factor (dB) | Cable Factor (dB) | Ant. Factor (dB) | Corrected Reading (dBuV) | Limits (dBuV) | Diff (dB) +=FAIL | Comments |
| 5180.00 | 60.00 | 100 | 225 | | | 9.54 | 2.98 | 34.39 | 87.83 | | | Ch. 36 |
| 5180.00 | | | | 46.33 | A | 9.54 | 2.98 | 34.39 | 74.16 | | | |
| 5240.00 | 74.00 | 150 | 180 | | | 9.54 | 3.00 | 34.48 | 101.94 | | | Ch. 48 |
| 5240.00 | | | | 58.83 | A | 9.54 | 3.00 | 34.48 | 86.77 | | | |
| 5260.00 | 76.67 | 125 | 180 | | | 9.54 | 3.00 | 34.52 | 104.65 | | | Ch. 52 |
| 5260.00 | | | | 61.50 | A | 9.54 | 3.00 | 34.52 | 89.48 | | | |
| 5320.00 | 63.67 | 100 | 225 | | | 9.54 | 3.02 | 34.61 | 91.76 | | | Ch. 64 |
| 5320.00 | | | | 49.00 | A | 9.54 | 3.02 | 34.61 | 77.09 | | | |

NOTE: Fundamental signals measured at 1 meter and extrapolated to 3 meters to calculate the radiated band edge field strengths.



Radiated Emissions Test Results (Continued)

*Band Edge Field Strength Measurements in 802.11n mode 20MHz Wide (5150-5350 MHz)
 Channels 36 & 64
 Continuous TX at Chain A Antenna port with Sony IRX-3980 Antennas
 Aegis Labs, Inc. File #: INTEL-070320-04*

| RADIATED EMISSIONS - Horizontal Antenna Polarization | | | | | | | | | | | | |
|---|----------------------|---------------------|-------------------|------------------------|---|----------------------|-------------------|------------------|--------------------------|---------------|------------------|---------------|
| Freq. (MHz) | Meter Reading (dBuV) | Antenna Height (cm) | Azimuth (degrees) | Quasi pk or AVG (dBuV) | | Distance Factor (dB) | Cable Factor (dB) | Ant. Factor (dB) | Corrected Reading (dBuV) | Limits (dBuV) | Diff (dB) +=FAIL | Comments |
| 5150.00 | 30.83 | 100 | 225 | | | 9.54 | 2.97 | 34.57 | 58.83 | 74.00 | -15.17 | Ch. 36 |
| 5150.00 | | | | 18.33 | A | 9.54 | 2.97 | 34.57 | 46.33 | 54.00 | -7.67 | |
| 5350.00 | 30.17 | 100 | 225 | | | 9.54 | 3.03 | 34.93 | 58.59 | 74.00 | -15.41 | Ch. 64 |
| 5350.00 | | | | 18.67 | A | 9.54 | 3.03 | 34.93 | 47.09 | 54.00 | -6.91 | |

| RADIATED EMISSIONS - Vertical Antenna Polarization | | | | | | | | | | | | |
|---|----------------------|---------------------|-------------------|------------------------|---|----------------------|-------------------|------------------|--------------------------|---------------|------------------|---------------|
| Freq. (MHz) | Meter Reading (dBuV) | Antenna Height (cm) | Azimuth (degrees) | Quasi pk or AVG (dBuV) | | Distance Factor (dB) | Cable Factor (dB) | Ant. Factor (dB) | Corrected Reading (dBuV) | Limits (dBuV) | Diff (dB) +=FAIL | Comments |
| 5150.00 | 30.17 | 100 | 225 | | | 9.54 | 2.97 | 34.34 | 57.94 | 74.00 | -16.06 | Ch. 36 |
| 5150.00 | | | | 18.33 | A | 9.54 | 2.97 | 34.34 | 46.10 | 54.00 | -7.90 | |
| 5350.00 | 29.83 | 100 | 225 | | | 9.54 | 3.03 | 34.66 | 57.98 | 74.00 | -16.02 | Ch. 64 |
| 5350.00 | | | | 18.67 | A | 9.54 | 3.03 | 34.66 | 46.82 | 54.00 | -7.18 | |

NOTE: The “Band Edge Field Strength” was calculated using the “Radiated Fundamental” measurements.



Radiated Emissions Test Results (Continued)

*Spurious Emissions Measurements in 802.11n mode 20MHz Wide (5150-5350 MHz)
 Channels 36, 52, & 64
 Continuous TX at Chain A Antenna port with Sony IRX-3980 Antennas
 Aegis Labs, Inc. File #: INTEL-070320-09*

| RADIATED EMISSIONS - Horizontal Antenna Polarization | | | | | | | | | | | | |
|---|----------------------|---------------------|-------------------|------------------------|--------------------|-------------------|------------------|--------------------------|---------------|------------------|----------|---------------|
| Freq. (MHz) | Meter Reading (dBuV) | Antenna Height (cm) | Azimuth (degrees) | Quasi pk or AVG (dBuV) | Preamp Factor (dB) | Cable Factor (dB) | Ant. Factor (dB) | Corrected Reading (dBuV) | Limits (dBuV) | Diff (dB) +=FAIL | Comments | |
| 3453.42 | 58.67 | 100 | 225 | | | 50.78 | 2.41 | 32.29 | 42.59 | 68.00 | -25.41 | Ch. 36 |
| 6906.66 | 59.00 | 100 | 225 | | | 50.50 | 3.47 | 35.91 | 47.87 | 68.00 | -20.13 | |
| 10359.58 | 64.17 | 100 | 180 | | | 50.39 | 4.39 | 38.62 | 56.79 | 68.00 | -11.21 | |
| 3506.27 | 59.17 | 100 | 225 | | | 50.76 | 2.43 | 32.41 | 43.26 | 68.00 | -24.74 | Ch. 52 |
| 7013.30 | 61.00 | 100 | 225 | | | 50.42 | 3.51 | 36.03 | 50.12 | 68.00 | -17.88 | |
| 10520.00 | 61.50 | 100 | 180 | | | 50.43 | 4.44 | 38.71 | 54.22 | 68.00 | -13.78 | |
| 3546.76 | 58.33 | 100 | 180 | | | 50.76 | 2.45 | 32.50 | 42.52 | 68.00 | -25.48 | Ch.64 |
| 7093.36 | 60.00 | 100 | 180 | | | 50.38 | 3.53 | 36.24 | 49.39 | 68.00 | -18.61 | |

| RADIATED EMISSIONS - Vertical Antenna Polarization | | | | | | | | | | | | |
|---|----------------------|---------------------|-------------------|------------------------|--------------------|-------------------|------------------|--------------------------|---------------|------------------|----------|---------------|
| Freq. (MHz) | Meter Reading (dBuV) | Antenna Height (cm) | Azimuth (degrees) | Quasi pk or AVG (dBuV) | Preamp Factor (dB) | Cable Factor (dB) | Ant. Factor (dB) | Corrected Reading (dBuV) | Limits (dBuV) | Diff (dB) +=FAIL | Comments | |
| 3453.39 | 57.33 | 100 | 225 | | | 50.78 | 2.41 | 31.80 | 40.76 | 68.00 | -27.24 | Ch. 36 |
| 6906.66 | 60.33 | 100 | 180 | | | 50.50 | 3.47 | 35.83 | 49.12 | 68.00 | -18.88 | |
| 10360.00 | 60.50 | 100 | 180 | | | 50.39 | 4.39 | 38.59 | 53.09 | 68.00 | -14.91 | |
| 3506.66 | 56.50 | 100 | 225 | | | 50.76 | 2.43 | 31.92 | 40.09 | 68.00 | -27.91 | Ch. 52 |
| 7013.34 | 61.00 | 100 | 180 | | | 50.42 | 3.51 | 35.93 | 50.02 | 68.00 | -17.98 | |
| 10520.00 | 62.50 | 100 | 225 | | | 50.43 | 4.44 | 38.70 | 55.22 | 68.00 | -12.78 | |
| 3546.66 | 57.17 | 100 | 225 | | | 50.76 | 2.45 | 32.02 | 40.88 | 68.00 | -27.12 | Ch.64 |
| 7093.35 | 60.00 | 100 | 180 | | | 50.38 | 3.53 | 36.14 | 49.29 | 68.00 | -18.71 | |



Radiated Emissions Test Results (Continued)

*Fundamental Measurements in 802.11n mode 20MHz Wide (5150-5350 MHz)
 Channels 36, 48, 52, & 64
 Continuous TX at Chain B Antenna port with Sony IRX-3980 Antennas
 Aegis Labs, Inc. File #: INTEL-070320-05*

| RADIATED EMISSIONS - Horizontal Antenna Polarization | | | | | | | | | | | | |
|---|----------------------|---------------------|-------------------|------------------------|---|----------------------|-------------------|------------------|--------------------------|---------------|------------------|---------------|
| Freq. (MHz) | Meter Reading (dBuV) | Antenna Height (cm) | Azimuth (degrees) | Quasi pk or AVG (dBuV) | | Distance Factor (dB) | Cable Factor (dB) | Ant. Factor (dB) | Corrected Reading (dBuV) | Limits (dBuV) | Diff (dB) +=FAIL | Comments |
| 5180.00 | 75.00 | 100 | 225 | | | 9.54 | 2.98 | 34.62 | 103.06 | | | Ch. 36 |
| 5180.00 | | | | 60.67 | A | 9.54 | 2.98 | 34.62 | 88.73 | | | |
| 5240.00 | 76.83 | 100 | 225 | | | 9.54 | 3.00 | 34.73 | 105.02 | | | Ch. 48 |
| 5240.00 | | | | 61.67 | A | 9.54 | 3.00 | 34.73 | 89.86 | | | |
| 5260.00 | 77.00 | 100 | 225 | | | 9.54 | 3.00 | 34.77 | 105.23 | | | Ch. 52 |
| 5260.00 | | | | 62.17 | A | 9.54 | 3.00 | 34.77 | 90.40 | | | |
| 5320.00 | 77.67 | 100 | 225 | | | 9.54 | 3.02 | 34.88 | 106.03 | | | Ch. 64 |
| 5320.00 | | | | 63.00 | A | 9.54 | 3.02 | 34.88 | 91.36 | | | |

| RADIATED EMISSIONS - Vertical Antenna Polarization | | | | | | | | | | | | |
|---|----------------------|---------------------|-------------------|------------------------|---|----------------------|-------------------|------------------|--------------------------|---------------|------------------|---------------|
| Freq. (MHz) | Meter Reading (dBuV) | Antenna Height (cm) | Azimuth (degrees) | Quasi pk or AVG (dBuV) | | Distance Factor (dB) | Cable Factor (dB) | Ant. Factor (dB) | Corrected Reading (dBuV) | Limits (dBuV) | Diff (dB) +=FAIL | Comments |
| 5180.00 | 74.33 | 100 | 225 | | | 9.54 | 2.98 | 34.39 | 102.16 | | | Ch. 36 |
| 5180.00 | | | | 58.83 | A | 9.54 | 2.98 | 34.39 | 86.66 | | | |
| 5240.00 | 74.67 | 100 | 225 | | | 9.54 | 3.00 | 34.48 | 102.61 | | | Ch. 48 |
| 5240.00 | | | | 59.67 | A | 9.54 | 3.00 | 34.48 | 87.61 | | | |
| 5260.00 | 73.83 | 100 | 225 | | | 9.54 | 3.00 | 34.52 | 101.81 | | | Ch. 52 |
| 5260.00 | | | | 60.33 | A | 9.54 | 3.00 | 34.52 | 88.31 | | | |
| 5320.00 | 74.33 | 100 | 135 | | | 9.54 | 3.02 | 34.61 | 102.42 | | | Ch. 64 |
| 5320.00 | | | | 60.00 | A | 9.54 | 3.02 | 34.61 | 88.09 | | | |

NOTE: Fundamental signals measured at 1 meter and extrapolated to 3 meters to calculate the radiated band edge field strengths.



Radiated Emissions Test Results (Continued)

*Band Edge Field Strength Measurements in 802.11n mode 20MHz Wide (5150-5350 MHz)
 Channels 36 & 64
 Continuous TX at Chain B Antenna port with Sony IRX-3980 Antennas
 Aegis Labs, Inc. File #: INTEL-070320-05*

RADIATED EMISSIONS - Horizontal Antenna Polarization

| Freq. (MHz) | Meter Reading (dBuV) | Antenna Height (cm) | Azimuth (degrees) | Quasi pk or AVG (dBuV) | | Distance Factor (dB) | Cable Factor (dB) | Ant. Factor (dB) | Corrected Reading (dBuV) | Limits (dBuV) | Diff (dB) +=FAIL | Comments |
|-------------|----------------------|---------------------|-------------------|------------------------|---|----------------------|-------------------|------------------|--------------------------|---------------|------------------|---------------|
| 5150.00 | 36.00 | 100 | 225 | | | 9.54 | 2.97 | 34.57 | 64.00 | 74.00 | -10.00 | Ch. 36 |
| 5150.00 | | | | 20.17 | A | 9.54 | 2.97 | 34.57 | 48.17 | 54.00 | -5.83 | |
| 5350.00 | 35.17 | 100 | 225 | | | 9.54 | 3.03 | 34.93 | 63.59 | 74.00 | -10.41 | Ch. 64 |
| 5350.00 | | | | 21.33 | A | 9.54 | 3.03 | 34.93 | 49.75 | 54.00 | -4.25 | |

RADIATED EMISSIONS - Vertical Antenna Polarization

| Freq. (MHz) | Meter Reading (dBuV) | Antenna Height (cm) | Azimuth (degrees) | Quasi pk or AVG (dBuV) | | Distance Factor (dB) | Cable Factor (dB) | Ant. Factor (dB) | Corrected Reading (dBuV) | Limits (dBuV) | Diff (dB) +=FAIL | Comments |
|-------------|----------------------|---------------------|-------------------|------------------------|---|----------------------|-------------------|------------------|--------------------------|---------------|------------------|---------------|
| 5150.00 | 32.50 | 100 | 225 | | | 9.54 | 2.97 | 34.34 | 60.27 | 74.00 | -13.73 | Ch. 36 |
| 5150.00 | | | | 19.33 | A | 9.54 | 2.97 | 34.34 | 47.10 | 54.00 | -6.90 | |
| 5350.00 | 32.00 | 100 | 135 | | | 9.54 | 3.03 | 34.66 | 60.15 | 74.00 | -13.85 | Ch. 64 |
| 5350.00 | | | | 19.83 | A | 9.54 | 3.03 | 34.66 | 47.98 | 54.00 | -6.02 | |

NOTE: The “Band Edge Field Strength” was calculated using the “Radiated Fundamental” measurements.



Radiated Emissions Test Results (Continued)

*Spurious Emissions Measurements in 802.11n mode 20MHz Wide (5150-5350 MHz)
Channels 36, 52, & 64
Continuous TX at Chain B Antenna port with Sony IRX-3980 Antennas
Aegis Labs, Inc. File #: INTEL-070320-10*

RADIATED EMISSIONS - Horizontal Antenna Polarization

| Freq. (MHz) | Meter Reading (dBuV) | Antenna Height (cm) | Azimuth (degrees) | Quasi pk or AVG (dBuV) | Preamp Factor (dB) | Cable Factor (dB) | Ant. Factor (dB) | Corrected Reading (dBuV) | Limits (dBuV) | Diff (dB) +=FAIL | Comments | |
|-------------|----------------------|---------------------|-------------------|------------------------|--------------------|-------------------|------------------|--------------------------|---------------|------------------|----------|---------------|
| 3453.42 | 59.50 | 100 | 225 | | | 50.78 | 2.41 | 32.29 | 43.42 | 68.00 | -24.58 | Ch. 36 |
| 6906.66 | 60.83 | 100 | 225 | | | 50.50 | 3.47 | 35.91 | 49.70 | 68.00 | -18.30 | |
| 10359.58 | 65.33 | 100 | 180 | | | 50.39 | 4.39 | 38.62 | 57.95 | 68.00 | -10.05 | |
| 3506.27 | 61.00 | 100 | 225 | | | 50.76 | 2.43 | 32.41 | 45.09 | 68.00 | -22.91 | Ch. 52 |
| 7013.30 | 59.83 | 100 | 180 | | | 50.42 | 3.51 | 36.03 | 48.95 | 68.00 | -19.05 | |
| 10519.98 | 67.17 | 100 | 180 | | | 50.43 | 4.44 | 38.71 | 59.89 | 68.00 | -8.11 | |
| 3546.76 | 60.50 | 100 | 225 | | | 50.76 | 2.45 | 32.50 | 44.69 | 68.00 | -23.31 | Ch.64 |
| 7093.36 | 58.00 | 100 | 225 | | | 50.38 | 3.53 | 36.24 | 47.39 | 68.00 | -20.61 | |
| 10620.00 | 68.50 | 100 | 225 | | | 50.43 | 4.45 | 38.75 | 61.27 | 74.00 | -12.73 | |
| 10620.00 | | | | 52.69 | A | 50.43 | 4.45 | 38.75 | 45.46 | 54.00 | -8.54 | |

RADIATED EMISSIONS - Vertical Antenna Polarization

| Freq. (MHz) | Meter Reading (dBuV) | Antenna Height (cm) | Azimuth (degrees) | Quasi pk or AVG (dBuV) | Preamp Factor (dB) | Cable Factor (dB) | Ant. Factor (dB) | Corrected Reading (dBuV) | Limits (dBuV) | Diff (dB) +=FAIL | Comments | |
|-------------|----------------------|---------------------|-------------------|------------------------|--------------------|-------------------|------------------|--------------------------|---------------|------------------|----------|---------------|
| 3453.31 | 60.83 | 100 | 225 | | | 50.78 | 2.41 | 31.80 | 44.26 | 68.00 | -23.74 | Ch. 36 |
| 6906.66 | 62.17 | 100 | 135 | | | 50.50 | 3.47 | 35.83 | 50.96 | 68.00 | -17.04 | |
| 10360.00 | 69.67 | 100 | 135 | | | 50.39 | 4.39 | 38.59 | 62.26 | 68.00 | -5.74 | |
| 3506.66 | 62.00 | 100 | 225 | | | 50.76 | 2.43 | 31.92 | 45.59 | 68.00 | -22.41 | Ch. 52 |
| 7013.34 | 63.67 | 100 | 135 | | | 50.42 | 3.51 | 35.93 | 52.69 | 68.00 | -15.31 | |
| 10519.98 | 70.83 | 100 | 135 | | | 50.43 | 4.44 | 38.70 | 63.55 | 68.00 | -4.45 | |
| 3546.66 | 60.00 | 100 | 135 | | | 50.76 | 2.45 | 32.02 | 43.71 | 68.00 | -24.29 | Ch.64 |
| 7093.35 | 58.67 | 100 | 135 | | | 50.38 | 3.53 | 36.14 | 47.96 | 68.00 | -20.04 | |
| 10639.98 | 68.83 | 100 | 180 | | | 50.44 | 4.46 | 38.73 | 61.58 | 74.00 | -12.42 | |
| 10639.98 | | | | 54.13 | A | 50.44 | 4.46 | 38.73 | 46.88 | 54.00 | -7.12 | |



Radiated Emissions Test Results (Continued)

*Fundamental Measurements in 802.11n mode 20MHz Wide (5150-5350 MHz)
Channels 36, 52, & 64
Continuous TX at Dual Chain AB Antenna port with Sony IRX-3980 Antennas
Aegis Labs, Inc. File #: INTEL-070320-06*

| RADIATED EMISSIONS - Horizontal Antenna Polarization | | | | | | | | | | | | |
|---|----------------------|---------------------|-------------------|------------------------|---|----------------------|-------------------|------------------|--------------------------|---------------|------------------|---------------|
| Freq. (MHz) | Meter Reading (dBuV) | Antenna Height (cm) | Azimuth (degrees) | Quasi pk or AVG (dBuV) | | Distance Factor (dB) | Cable Factor (dB) | Ant. Factor (dB) | Corrected Reading (dBuV) | Limits (dBuV) | Diff (dB) +=FAIL | Comments |
| 5180.00 | 76.17 | 100 | 225 | | | 9.54 | 2.98 | 34.62 | 104.23 | | | Ch. 36 |
| 5180.00 | | | | 58.67 | A | 9.54 | 2.98 | 34.62 | 86.73 | | | |
| 5260.00 | 77.00 | 100 | 225 | | | 9.54 | 3.00 | 34.77 | 105.23 | | | Ch. 52 |
| 5260.00 | | | | 61.83 | A | 9.54 | 3.00 | 34.77 | 90.06 | | | |
| 5320.00 | 77.00 | 100 | 225 | | | 9.54 | 3.02 | 34.88 | 105.36 | | | Ch. 64 |
| 5320.00 | | | | 57.33 | A | 9.54 | 3.02 | 34.88 | 85.69 | | | |

| RADIATED EMISSIONS - Vertical Antenna Polarization | | | | | | | | | | | | |
|---|----------------------|---------------------|-------------------|------------------------|---|----------------------|-------------------|------------------|--------------------------|---------------|------------------|---------------|
| Freq. (MHz) | Meter Reading (dBuV) | Antenna Height (cm) | Azimuth (degrees) | Quasi pk or AVG (dBuV) | | Distance Factor (dB) | Cable Factor (dB) | Ant. Factor (dB) | Corrected Reading (dBuV) | Limits (dBuV) | Diff (dB) +=FAIL | Comments |
| 5180.00 | 72.33 | 100 | 225 | | | 9.54 | 2.98 | 34.39 | 100.16 | | | Ch. 36 |
| 5180.00 | | | | 57.17 | A | 9.54 | 2.98 | 34.39 | 85.00 | | | |
| 5260.00 | 76.67 | 125 | 180 | | | 9.54 | 3.00 | 34.52 | 104.65 | | | Ch. 52 |
| 5260.00 | | | | 61.50 | A | 9.54 | 3.00 | 34.52 | 89.48 | | | |
| 5320.00 | 76.00 | 125 | 225 | | | 9.54 | 3.02 | 34.61 | 104.09 | | | Ch. 64 |
| 5320.00 | | | | 56.50 | A | 9.54 | 3.02 | 34.61 | 84.59 | | | |

NOTE: Fundamental signals measured at 1 meter and extrapolated to 3 meters to calculate the radiated band edge field strengths.



Radiated Emissions Test Results (Continued)

*Band Edge Field Strength Measurements in 802.11n mode 20MHz Wide (5150-5350 MHz)
 Channels 36 & 64
 Continuous TX at Dual Chain AB Antenna port with Sony IRX-3980 Antennas
 Aegis Labs, Inc. File #: INTEL-070320-06*

| RADIATED EMISSIONS - Horizontal Antenna Polarization | | | | | | | | | | | | |
|---|----------------------|---------------------|-------------------|------------------------|---|----------------------|-------------------|------------------|--------------------------|---------------|------------------|---------------|
| Freq. (MHz) | Meter Reading (dBuV) | Antenna Height (cm) | Azimuth (degrees) | Quasi pk or AVG (dBuV) | | Distance Factor (dB) | Cable Factor (dB) | Ant. Factor (dB) | Corrected Reading (dBuV) | Limits (dBuV) | Diff (dB) +=FAIL | Comments |
| 5150.00 | 30.33 | 100 | 225 | | | 9.54 | 2.97 | 34.57 | 58.33 | 74.00 | -15.67 | Ch. 36 |
| 5150.00 | | | | 19.00 | A | 9.54 | 2.97 | 34.57 | 47.00 | 54.00 | -7.00 | |
| 5350.00 | 32.00 | 100 | 225 | | | 9.54 | 3.03 | 34.93 | 60.42 | 74.00 | -13.58 | Ch. 64 |
| 5350.00 | | | | 19.83 | A | 9.54 | 3.03 | 34.93 | 48.25 | 54.00 | -5.75 | |

| RADIATED EMISSIONS - Vertical Antenna Polarization | | | | | | | | | | | | |
|---|----------------------|---------------------|-------------------|------------------------|---|----------------------|-------------------|------------------|--------------------------|---------------|------------------|---------------|
| Freq. (MHz) | Meter Reading (dBuV) | Antenna Height (cm) | Azimuth (degrees) | Quasi pk or AVG (dBuV) | | Distance Factor (dB) | Cable Factor (dB) | Ant. Factor (dB) | Corrected Reading (dBuV) | Limits (dBuV) | Diff (dB) +=FAIL | Comments |
| 5150.00 | 30.17 | 100 | 225 | | | 9.54 | 2.97 | 34.34 | 57.94 | 74.00 | -16.06 | Ch. 36 |
| 5150.00 | | | | 18.50 | A | 9.54 | 2.97 | 34.34 | 46.27 | 54.00 | -7.73 | |
| 5350.00 | 31.50 | 125 | 225 | | | 9.54 | 3.03 | 34.66 | 59.65 | 74.00 | -14.35 | Ch. 64 |
| 5350.00 | | | | 19.67 | A | 9.54 | 3.03 | 34.66 | 47.82 | 54.00 | -6.18 | |

NOTE: The “Band Edge Field Strength” was calculated using the “Radiated Fundamental” measurements.



Radiated Emissions Test Results (Continued)

*Spurious Emissions Measurements in 802.11n mode 20MHz Wide (5150-5350 MHz)
Channels 36, 52, & 64
Continuous TX at Dual Chain AB Antenna port with Sony IRX-3980 Antennas
Aegis Labs, Inc. File #: INTEL-070320-11*

RADIATED EMISSIONS - Horizontal Antenna Polarization

| Freq. (MHz) | Meter Reading (dBuV) | Antenna Height (cm) | Azimuth (degrees) | Quasi pk or AVG (dBuV) | Preamp Factor (dB) | Cable Factor (dB) | Ant. Factor (dB) | Corrected Reading (dBuV) | Limits (dBuV) | Diff (dB) +=FAIL | Comments |
|-------------|----------------------|---------------------|-------------------|------------------------|--------------------|-------------------|------------------|--------------------------|---------------|------------------|---------------|
| 3453.42 | 61.50 | 200 | 225 | | 50.78 | 2.41 | 32.29 | 45.42 | 68.00 | -22.58 | Ch. 36 |
| 6906.66 | 61.67 | 100 | 180 | | 50.50 | 3.47 | 35.91 | 50.54 | 68.00 | -17.46 | |
| 10359.58 | 58.67 | 100 | 180 | | 50.39 | 4.39 | 38.62 | 51.29 | 68.00 | -16.71 | |
| 3506.66 | 61.83 | 200 | 225 | | 50.76 | 2.43 | 32.41 | 45.92 | 68.00 | -22.08 | Ch. 52 |
| 7013.30 | 56.33 | 100 | 180 | | 50.42 | 3.51 | 36.03 | 45.45 | 68.00 | -22.55 | |
| 10520.00 | 53.00 | 100 | 180 | | 50.43 | 4.44 | 38.71 | 45.72 | 68.00 | -22.28 | |
| 3546.76 | 55.50 | 100 | 225 | | 50.76 | 2.45 | 32.50 | 39.69 | 68.00 | -28.31 | Ch.64 |
| 7093.36 | 56.17 | 100 | 180 | | 50.38 | 3.53 | 36.24 | 45.56 | 68.00 | -22.44 | |
| 10640.00 | 55.83 | 125 | 225 | | 50.44 | 4.46 | 38.76 | 48.61 | 74.00 | -25.39 | |
| 10640.00 | | | | 42.66 A | 50.44 | 4.46 | 38.76 | 35.44 | 54.00 | -18.56 | |

RADIATED EMISSIONS - Vertical Antenna Polarization

| Freq. (MHz) | Meter Reading (dBuV) | Antenna Height (cm) | Azimuth (degrees) | Quasi pk or AVG (dBuV) | Preamp Factor (dB) | Cable Factor (dB) | Ant. Factor (dB) | Corrected Reading (dBuV) | Limits (dBuV) | Diff (dB) +=FAIL | Comments |
|-------------|----------------------|---------------------|-------------------|------------------------|--------------------|-------------------|------------------|--------------------------|---------------|------------------|---------------|
| 3453.31 | 60.83 | 100 | 180 | | 50.78 | 2.41 | 31.80 | 44.26 | 68.00 | -23.74 | Ch. 36 |
| 6906.66 | 62.50 | 100 | 180 | | 50.50 | 3.47 | 35.83 | 51.29 | 68.00 | -16.71 | |
| 10360.00 | 63.17 | 100 | 180 | | 50.39 | 4.39 | 38.59 | 55.76 | 68.00 | -12.24 | |
| 3506.66 | 60.83 | 100 | 225 | | 50.76 | 2.43 | 31.92 | 44.42 | 68.00 | -23.58 | Ch. 52 |
| 7013.34 | 62.50 | 100 | 225 | | 50.42 | 3.51 | 35.93 | 51.52 | 68.00 | -16.48 | |
| 10520.00 | 66.00 | 100 | 135 | | 50.43 | 4.44 | 38.70 | 58.72 | 68.00 | -9.28 | |
| 3546.66 | 55.67 | 100 | 180 | | 50.76 | 2.45 | 32.02 | 39.38 | 68.00 | -28.62 | Ch.64 |
| 7093.35 | 52.33 | 100 | 180 | | 50.38 | 3.53 | 36.14 | 41.62 | 68.00 | -26.38 | |
| 10640.00 | 52.67 | 100 | 180 | | 50.44 | 4.46 | 38.73 | 45.42 | 74.00 | -28.58 | |
| 10640.00 | | | | 41.48 A | 50.44 | 4.46 | 38.73 | 34.23 | 54.00 | -19.77 | |



RADIATED EMISSIONS TEST RESULTS

| | | | |
|-----------------------|--|----------------------------|--------------|
| CLIENT: | Intel Corporation | DATE: | 03/21/07 |
| EUT: | Intel Wireless WiFi Link 4965AGN | PROJECT NUMBER: | INTEL-070320 |
| MODEL NUMBER: | 4965AGN | TEST ENGINEER: | BM/JC |
| SERIAL NUMBER: | 0013E804612B | SITE #: | 1 |
| CONFIGURATION: | Tested installed in the host computer's mini PCI slot in 802.11n (5150-5350 MHz) mode 40MHz Wide with Sony IRX-3980 Antennas. | TEMPERATURE: | 10 deg. C |
| | | HUMIDITY: | 62% RH |
| | | TIME: | 7:00 PM |

| | |
|---------------------|---|
| Description: | Radiated RF Emissions (1 GHz – 18 GHz) |
| Results: | PASSED Horizontal and Vertical Antenna Polarizations Class B Limits |
| Note: | Radiated Emissions Measurements were performed on the EUT with power supply set at the following voltage and frequency. <ul style="list-style-type: none"> 120VAC / 60 Hz. |

| Unwanted Spurious Emissions Limits | | | |
|------------------------------------|-----------------------|--|--|
| Frequency (MHz) | Field Strength (uV/m) | Field Strength (dBuV/m) (Emissions in the restricted bands) | Field Strength (dBm/MHz) (Emissions outside the restricted bands) |
| Above 960 | 500 | 54.00 (Average) 74.00 (Peak) | < -20 dBc |

Radiated Emissions Sample Calculations

$$\text{Corrected Meter Reading} = \text{Meter Reading} + F + C - D$$

Where, F = Antenna Factor

C = Cable Factor

G = Amplifier Gain

D = Distance Factor (if applicable)

Therefore, the equation for determining the Corrected Meter Reading Limit (CML) is:

$$\text{CML} = \text{Specification Limit} - F - C + D$$



Radiated Emissions Test Results (Continued)

*Fundamental Measurements in 802.11n mode 40MHz Wide (5150-5350 MHz)
 Channels 38, 54, & 62
 Continuous TX at Chain A Antenna port with Sony IRX-3980 Antennas
 Aegis Labs, Inc. File #: INTEL-070320-04*

| RADIATED EMISSIONS - Horizontal Antenna Polarization | | | | | | | | | | | | |
|---|----------------------|---------------------|-------------------|------------------------|---|----------------------|-------------------|------------------|--------------------------|---------------|------------------|---------------|
| Freq. (MHz) | Meter Reading (dBuV) | Antenna Height (cm) | Azimuth (degrees) | Quasi pk or AVG (dBuV) | | Distance Factor (dB) | Cable Factor (dB) | Ant. Factor (dB) | Corrected Reading (dBuV) | Limits (dBuV) | Diff (dB) +=FAIL | Comments |
| 5190.00 | 72.33 | 100 | 225 | | | 9.54 | 2.98 | 34.64 | 100.41 | | | Ch. 38 |
| 5190.00 | | | | 56.50 | A | 9.54 | 2.98 | 34.64 | 84.58 | | | |
| 5270.00 | 56.67 | 125 | 225 | | | 9.54 | 3.01 | 34.79 | 84.92 | | | Ch. 54 |
| 5270.00 | | | | 44.00 | A | 9.54 | 3.01 | 34.79 | 72.25 | | | |
| 5310.00 | 61.00 | 100 | 225 | | | 9.54 | 3.02 | 34.86 | 89.34 | | | Ch. 62 |
| 5310.00 | | | | 48.17 | A | 9.54 | 3.02 | 34.86 | 76.51 | | | |

| RADIATED EMISSIONS - Vertical Antenna Polarization | | | | | | | | | | | | |
|---|----------------------|---------------------|-------------------|------------------------|---|----------------------|-------------------|------------------|--------------------------|---------------|------------------|---------------|
| Freq. (MHz) | Meter Reading (dBuV) | Antenna Height (cm) | Azimuth (degrees) | Quasi pk or AVG (dBuV) | | Distance Factor (dB) | Cable Factor (dB) | Ant. Factor (dB) | Corrected Reading (dBuV) | Limits (dBuV) | Diff (dB) +=FAIL | Comments |
| 5190.00 | 71.00 | 100 | 225 | | | 9.54 | 2.98 | 34.40 | 98.85 | | | Ch. 38 |
| 5190.00 | | | | 55.33 | A | 9.54 | 2.98 | 34.40 | 83.18 | | | |
| 5270.00 | 56.17 | 100 | 180 | | | 9.54 | 3.01 | 34.53 | 84.17 | | | Ch. 54 |
| 5270.00 | | | | 44.50 | A | 9.54 | 3.01 | 34.53 | 72.50 | | | |
| 5310.00 | 58.50 | 100 | 225 | | | 9.54 | 3.02 | 34.60 | 86.57 | | | Ch. 62 |
| 5310.00 | | | | 46.00 | A | 9.54 | 3.02 | 34.60 | 74.07 | | | |

NOTE: Fundamental signals measured at 1 meter and extrapolated to 3 meters to calculate the radiated band edge field strengths.



Radiated Emissions Test Results (Continued)

*Band Edge Field Strength Measurements in 802.11n mode 40MHz Wide (5150-5350 MHz)
 Channels 38 & 62
 Continuous TX at Chain A Antenna port with Sony IRX-3980 Antennas
 Aegis Labs, Inc. File #: INTEL-070320-04*

| RADIATED EMISSIONS - Horizontal Antenna Polarization | | | | | | | | | | | | |
|---|----------------------|---------------------|-------------------|------------------------|---|----------------------|-------------------|------------------|--------------------------|---------------|------------------|---------------|
| Freq. (MHz) | Meter Reading (dBuV) | Antenna Height (cm) | Azimuth (degrees) | Quasi pk or AVG (dBuV) | | Distance Factor (dB) | Cable Factor (dB) | Ant. Factor (dB) | Corrected Reading (dBuV) | Limits (dBuV) | Diff (dB) +=FAIL | Comments |
| 5150.00 | 37.83 | 100 | 225 | | | 9.54 | 2.97 | 34.57 | 65.83 | 74.00 | -8.17 | Ch. 38 |
| 5150.00 | | | | 23.17 | A | 9.54 | 2.97 | 34.57 | 51.17 | 54.00 | -2.83 | |
| 5350.00 | 32.67 | 100 | 225 | | | 9.54 | 3.03 | 34.93 | 61.09 | 74.00 | -12.91 | Ch. 62 |
| 5350.00 | | | | 19.50 | A | 9.54 | 3.03 | 34.93 | 47.92 | 54.00 | -6.08 | |

| RADIATED EMISSIONS - Vertical Antenna Polarization | | | | | | | | | | | | |
|---|----------------------|---------------------|-------------------|------------------------|---|----------------------|-------------------|------------------|--------------------------|---------------|------------------|---------------|
| Freq. (MHz) | Meter Reading (dBuV) | Antenna Height (cm) | Azimuth (degrees) | Quasi pk or AVG (dBuV) | | Distance Factor (dB) | Cable Factor (dB) | Ant. Factor (dB) | Corrected Reading (dBuV) | Limits (dBuV) | Diff (dB) +=FAIL | Comments |
| 5150.00 | 34.00 | 100 | 225 | | | 9.54 | 2.97 | 34.34 | 61.77 | 74.00 | -12.23 | Ch. 38 |
| 5150.00 | | | | 21.50 | A | 9.54 | 2.97 | 34.34 | 49.27 | 54.00 | -4.73 | |
| 5350.00 | 31.33 | 100 | 225 | | | 9.54 | 3.03 | 34.66 | 59.48 | 74.00 | -14.52 | Ch. 62 |
| 5350.00 | | | | 19.00 | A | 9.54 | 3.03 | 34.66 | 47.15 | 54.00 | -6.85 | |

NOTE: The “Band Edge Field Strength” was calculated using the “Radiated Fundamental” measurements.



Radiated Emissions Test Results (Continued)

*Spurious Emissions Measurements in 802.11n mode 40MHz Wide (5150-5350 MHz)
 Channels 38, 54, & 62
 Continuous TX at Chain A Antenna port with Sony IRX-3980 Antennas
 Aegis Labs, Inc. File #: INTEL-070320-09*

RADIATED EMISSIONS - Horizontal Antenna Polarization

| Freq. (MHz) | Meter Reading (dBuV) | Antenna Height (cm) | Azimuth (degrees) | Quasi pk or AVG (dBuV) | Preamp Factor (dB) | Cable Factor (dB) | Ant. Factor (dB) | Corrected Reading (dBuV) | Limits (dBuV) | Diff (dB) +=FAIL | Comments | |
|-------------|----------------------|---------------------|-------------------|------------------------|--------------------|-------------------|------------------|--------------------------|---------------|------------------|---------------|--|
| 3460.00 | 57.83 | 100 | 225 | | 50.78 | 2.42 | 32.30 | 41.77 | 68.00 | -26.23 | Ch. 38 | |
| 6920.13 | 57.00 | 100 | 225 | | 50.49 | 3.48 | 35.92 | 45.90 | 68.00 | -22.10 | | |
| 10379.39 | 60.83 | 100 | 180 | | 50.39 | 4.40 | 38.63 | 53.46 | 68.00 | -14.54 | | |
| 3513.33 | 57.83 | 100 | 225 | | 50.76 | 2.44 | 32.43 | 41.93 | 68.00 | -26.07 | Ch. 54 | |
| 7026.76 | 59.67 | 100 | 225 | | 50.42 | 3.51 | 36.07 | 48.83 | 68.00 | -19.17 | | |
| 10540.22 | 58.33 | 100 | 225 | | 50.43 | 4.45 | 38.72 | 51.06 | 68.00 | -16.94 | | |
| 3539.88 | 58.00 | 100 | 180 | | 50.76 | 2.45 | 32.49 | 42.17 | 68.00 | -25.83 | Ch.62 | |
| 7080.03 | 59.00 | 100 | 180 | | 50.39 | 3.52 | 36.21 | 48.34 | 68.00 | -19.66 | | |
| 10620.47 | 59.67 | 100 | 180 | | 50.43 | 4.45 | 38.75 | 52.44 | 74.00 | -21.56 | | |
| 10620.47 | | | | 45.79 | A | 50.43 | 4.45 | 38.75 | 38.56 | 54.00 | -15.44 | |

RADIATED EMISSIONS - Vertical Antenna Polarization

| Freq. (MHz) | Meter Reading (dBuV) | Antenna Height (cm) | Azimuth (degrees) | Quasi pk or AVG (dBuV) | Preamp Factor (dB) | Cable Factor (dB) | Ant. Factor (dB) | Corrected Reading (dBuV) | Limits (dBuV) | Diff (dB) +=FAIL | Comments | |
|-------------|----------------------|---------------------|-------------------|------------------------|--------------------|-------------------|------------------|--------------------------|---------------|------------------|---------------|--|
| 3460.00 | 57.33 | 100 | 180 | | 50.78 | 2.42 | 31.81 | 40.78 | 68.00 | -27.22 | Ch. 38 | |
| 6920.13 | 59.83 | 100 | 225 | | 50.49 | 3.48 | 35.84 | 48.65 | 68.00 | -19.35 | | |
| 10379.60 | 59.67 | 100 | 135 | | 50.39 | 4.40 | 38.60 | 52.28 | 68.00 | -15.72 | | |
| 3513.33 | 59.00 | 100 | 225 | | 50.76 | 2.44 | 31.93 | 42.61 | 68.00 | -25.39 | Ch. 54 | |
| 7026.76 | 59.83 | 100 | 180 | | 50.42 | 3.51 | 35.97 | 48.89 | 68.00 | -19.11 | | |
| 10540.22 | 60.83 | 100 | 180 | | 50.43 | 4.45 | 38.71 | 53.55 | 68.00 | -14.45 | | |
| 3540.11 | 56.33 | 100 | 225 | | 50.76 | 2.45 | 32.00 | 40.02 | 68.00 | -27.98 | Ch.62 | |
| 7080.01 | 61.33 | 100 | 225 | | 50.39 | 3.52 | 36.11 | 50.57 | 68.00 | -17.43 | | |
| 10620.41 | 60.17 | 100 | 180 | | 50.43 | 4.45 | 38.72 | 52.91 | 74.00 | -21.09 | | |
| 10620.41 | | | | 47.10 | A | 50.43 | 4.45 | 38.72 | 39.84 | 54.00 | -14.16 | |



Radiated Emissions Test Results (Continued)

*Spurious Emissions Measurements in 802.11n mode 40MHz Wide (5150-5350 MHz)
 Channels 38, 54, & 62
 Continuous RX at Chain A Antenna port with Sony IRX-3980 Antennas
 Aegis Labs, Inc. File #: INTEL-070320-09*

RADIATED EMISSIONS - Horizontal Antenna Polarization

| Freq. (MHz) | Meter Reading (dBuV) | Antenna Height (cm) | Azimuth (degrees) | Quasi pk or AVG (dBuV) | | Preamp Factor (dB) | Cable Factor (dB) | Ant. Factor (dB) | Corrected Reading (dBuV) | Limits (dBuV) | Diff (dB) +=FAIL | Comments |
|-------------|----------------------|---------------------|-------------------|------------------------|---|--------------------|-------------------|------------------|--------------------------|---------------|------------------|---------------|
| 3460.00 | 58.00 | 125 | 225 | | | 50.78 | 2.42 | 32.30 | 41.94 | 74.00 | -32.06 | Ch. 38 |
| 3460.00 | | | | 50.68 | A | 50.78 | 2.42 | 32.30 | 34.62 | 54.00 | -19.38 | |
| 3513.32 | 58.83 | 100 | 180 | | | 50.76 | 2.44 | 32.43 | 42.93 | 74.00 | -31.07 | Ch. 54 |
| 3513.32 | | | | 49.11 | A | 50.76 | 2.44 | 32.43 | 33.21 | 54.00 | -20.79 | |
| 3540.21 | 57.83 | 100 | 180 | | | 50.76 | 2.45 | 32.49 | 42.00 | 74.00 | -32.00 | Ch.62 |
| 3540.21 | | | | 48.67 | A | 50.76 | 2.45 | 32.49 | 32.84 | 54.00 | -21.16 | |

RADIATED EMISSIONS - Vertical Antenna Polarization

| Freq. (MHz) | Meter Reading (dBuV) | Antenna Height (cm) | Azimuth (degrees) | Quasi pk or AVG (dBuV) | | Preamp Factor (dB) | Cable Factor (dB) | Ant. Factor (dB) | Corrected Reading (dBuV) | Limits (dBuV) | Diff (dB) +=FAIL | Comments |
|-------------|----------------------|---------------------|-------------------|------------------------|---|--------------------|-------------------|------------------|--------------------------|---------------|------------------|---------------|
| 3460.02 | 62.50 | 100 | 135 | | | 50.78 | 2.42 | 31.81 | 45.95 | 74.00 | -28.05 | Ch. 38 |
| 3460.02 | | | | 48.52 | A | 50.78 | 2.42 | 31.81 | 31.97 | 54.00 | -22.03 | |
| 3513.33 | 60.33 | 100 | 180 | | | 50.76 | 2.44 | 31.93 | 43.94 | 74.00 | -30.06 | Ch. 54 |
| 3513.33 | | | | 48.97 | A | 50.76 | 2.44 | 31.93 | 32.58 | 54.00 | -21.42 | |
| 3540.02 | 56.17 | 100 | 180 | | | 50.76 | 2.45 | 32.00 | 39.86 | 74.00 | -34.14 | Ch.62 |
| 3540.02 | | | | 46.59 | A | 50.76 | 2.45 | 32.00 | 30.28 | 54.00 | -23.72 | |



Radiated Emissions Test Results (Continued)

*Fundamental Measurements in 802.11n mode 40MHz Wide (5150-5350 MHz)
Channels 38, 54, & 62
Continuous TX at Chain B Antenna port with Sony IRX-3980 Antennas
Aegis Labs, Inc. File #: INTEL-070320-05*

| RADIATED EMISSIONS - Horizontal Antenna Polarization | | | | | | | | | | | | |
|---|----------------------|---------------------|-------------------|------------------------|---|----------------------|-------------------|------------------|--------------------------|---------------|------------------|---------------|
| Freq. (MHz) | Meter Reading (dBuV) | Antenna Height (cm) | Azimuth (degrees) | Quasi pk or AVG (dBuV) | | Distance Factor (dB) | Cable Factor (dB) | Ant. Factor (dB) | Corrected Reading (dBuV) | Limits (dBuV) | Diff (dB) +=FAIL | Comments |
| 5190.00 | 72.50 | 100 | 225 | | | 9.54 | 2.98 | 34.64 | 100.58 | | | Ch. 38 |
| 5190.00 | | | | 54.17 | A | 9.54 | 2.98 | 34.64 | 82.25 | | | |
| 5270.00 | 75.17 | 100 | 225 | | | 9.54 | 3.01 | 34.79 | 103.42 | | | Ch. 54 |
| 5270.00 | | | | 56.33 | A | 9.54 | 3.01 | 34.79 | 84.58 | | | |
| 5310.00 | 74.00 | 100 | 225 | | | 9.54 | 3.02 | 34.86 | 102.34 | | | Ch. 62 |
| 5310.00 | | | | 56.00 | A | 9.54 | 3.02 | 34.86 | 84.34 | | | |

| RADIATED EMISSIONS - Vertical Antenna Polarization | | | | | | | | | | | | |
|---|----------------------|---------------------|-------------------|------------------------|---|----------------------|-------------------|------------------|--------------------------|---------------|------------------|---------------|
| Freq. (MHz) | Meter Reading (dBuV) | Antenna Height (cm) | Azimuth (degrees) | Quasi pk or AVG (dBuV) | | Distance Factor (dB) | Cable Factor (dB) | Ant. Factor (dB) | Corrected Reading (dBuV) | Limits (dBuV) | Diff (dB) +=FAIL | Comments |
| 5190.00 | 71.50 | 100 | 225 | | | 9.54 | 2.98 | 34.40 | 99.35 | | | Ch. 38 |
| 5190.00 | | | | 52.83 | A | 9.54 | 2.98 | 34.40 | 80.68 | | | |
| 5270.00 | 70.50 | 100 | 225 | | | 9.54 | 3.01 | 34.53 | 98.50 | | | Ch. 54 |
| 5270.00 | | | | 51.50 | A | 9.54 | 3.01 | 34.53 | 79.50 | | | |
| 5310.00 | 71.33 | 100 | 225 | | | 9.54 | 3.02 | 34.60 | 99.40 | | | Ch. 62 |
| 5310.00 | | | | 53.33 | A | 9.54 | 3.02 | 34.60 | 81.40 | | | |

NOTE: Fundamental signals measured at 1 meter and extrapolated to 3 meters to calculate the radiated band edge field strengths.



Radiated Emissions Test Results (Continued)

*Band Edge Field Strength Measurements in 802.11n mode 40MHz Wide (5150-5350 MHz)
 Channels 38 & 62
 Continuous TX at Chain B Antenna port with Sony IRX-3980 Antennas
 Aegis Labs, Inc. File #: INTEL-070320-05*

RADIATED EMISSIONS - Horizontal Antenna Polarization

| Freq. (MHz) | Meter Reading (dBuV) | Antenna Height (cm) | Azimuth (degrees) | Quasi pk or AVG (dBuV) | | Distance Factor (dB) | Cable Factor (dB) | Ant. Factor (dB) | Corrected Reading (dBuV) | Limits (dBuV) | Diff (dB) +=FAIL | Comments |
|-------------|----------------------|---------------------|-------------------|------------------------|---|----------------------|-------------------|------------------|--------------------------|---------------|------------------|---------------|
| 5150.00 | 35.83 | 100 | 225 | | | 9.54 | 2.97 | 34.57 | 63.83 | 74.00 | -10.17 | Ch. 38 |
| 5150.00 | | | | 21.83 | A | 9.54 | 2.97 | 34.57 | 49.83 | 54.00 | -4.17 | |
| 5350.00 | 43.00 | 100 | 225 | | | 9.54 | 3.03 | 34.93 | 71.42 | 74.00 | -2.58 | Ch. 62 |
| 5350.00 | | | | 22.67 | A | 9.54 | 3.03 | 34.93 | 51.09 | 54.00 | -2.91 | |

RADIATED EMISSIONS - Vertical Antenna Polarization

| Freq. (MHz) | Meter Reading (dBuV) | Antenna Height (cm) | Azimuth (degrees) | Quasi pk or AVG (dBuV) | | Distance Factor (dB) | Cable Factor (dB) | Ant. Factor (dB) | Corrected Reading (dBuV) | Limits (dBuV) | Diff (dB) +=FAIL | Comments |
|-------------|----------------------|---------------------|-------------------|------------------------|---|----------------------|-------------------|------------------|--------------------------|---------------|------------------|---------------|
| 5150.00 | 35.17 | 100 | 225 | | | 9.54 | 2.97 | 34.34 | 62.94 | 74.00 | -11.06 | Ch. 38 |
| 5150.00 | | | | 21.00 | A | 9.54 | 2.97 | 34.34 | 48.77 | 54.00 | -5.23 | |
| 5350.00 | 35.33 | 100 | 225 | | | 9.54 | 3.03 | 34.66 | 63.48 | 74.00 | -10.52 | Ch. 62 |
| 5350.00 | | | | 20.50 | A | 9.54 | 3.03 | 34.66 | 48.65 | 54.00 | -5.35 | |

NOTE: The “Band Edge Field Strength” was calculated using the “Radiated Fundamental” measurements.



Radiated Emissions Test Results (Continued)

*Spurious Emissions Measurements in 802.11n mode 40MHz Wide (5150-5350 MHz)
 Channels 38, 54, & 62
 Continuous TX at Chain B Antenna port with Sony IRX-3980 Antennas
 Aegis Labs, Inc. File #: INTEL-070320-10*

RADIATED EMISSIONS - Horizontal Antenna Polarization

| Freq. (MHz) | Meter Reading (dBuV) | Antenna Height (cm) | Azimuth (degrees) | Quasi pk or AVG (dBuV) | Preamp Factor (dB) | Cable Factor (dB) | Ant. Factor (dB) | Corrected Reading (dBuV) | Limits (dBuV) | Diff (dB) +=FAIL | Comments |
|-------------|----------------------|---------------------|-------------------|------------------------|--------------------|-------------------|------------------|--------------------------|---------------|------------------|---------------|
| 3460.00 | 58.33 | 100 | 225 | | 50.78 | 2.42 | 32.30 | 42.27 | 68.00 | -25.73 | Ch. 38 |
| 6920.13 | 59.00 | 100 | 135 | | 50.49 | 3.48 | 35.92 | 47.90 | 68.00 | -20.10 | |
| 10379.99 | 58.83 | 100 | 180 | | 50.39 | 4.40 | 38.63 | 51.46 | 68.00 | -16.54 | |
| 3513.33 | 60.00 | 100 | 225 | | 50.76 | 2.44 | 32.43 | 44.10 | 68.00 | -23.90 | Ch. 54 |
| 7026.76 | 61.83 | 100 | 135 | | 50.42 | 3.51 | 36.07 | 50.99 | 68.00 | -17.01 | |
| 10540.22 | 61.50 | 100 | 135 | | 50.43 | 4.45 | 38.72 | 54.23 | 68.00 | -13.77 | |
| 3540.03 | 59.67 | 100 | 225 | | 50.76 | 2.45 | 32.49 | 43.84 | 68.00 | -24.16 | Ch.62 |
| 7080.03 | 59.67 | 100 | 135 | | 50.39 | 3.52 | 36.21 | 49.01 | 68.00 | -18.99 | |
| 10620.47 | 60.50 | 100 | 135 | | 50.43 | 4.45 | 38.75 | 53.27 | 74.00 | -20.73 | |
| 10620.47 | | | | 47.18 A | 50.43 | 4.45 | 38.75 | 39.95 | 54.00 | -14.05 | |

RADIATED EMISSIONS - Vertical Antenna Polarization

| Freq. (MHz) | Meter Reading (dBuV) | Antenna Height (cm) | Azimuth (degrees) | Quasi pk or AVG (dBuV) | Preamp Factor (dB) | Cable Factor (dB) | Ant. Factor (dB) | Corrected Reading (dBuV) | Limits (dBuV) | Diff (dB) +=FAIL | Comments |
|-------------|----------------------|---------------------|-------------------|------------------------|--------------------|-------------------|------------------|--------------------------|---------------|------------------|---------------|
| 3460.00 | 59.50 | 100 | 225 | | 50.78 | 2.42 | 31.81 | 42.95 | 68.00 | -25.05 | Ch. 38 |
| 6920.13 | 59.00 | 100 | 135 | | 50.49 | 3.48 | 35.84 | 47.82 | 68.00 | -20.18 | |
| 10380.00 | 63.00 | 100 | 135 | | 50.39 | 4.40 | 38.60 | 55.61 | 68.00 | -12.39 | |
| 3513.33 | 61.17 | 100 | 225 | | 50.76 | 2.44 | 31.93 | 44.78 | 68.00 | -23.22 | Ch. 54 |
| 7026.76 | 60.33 | 100 | 180 | | 50.42 | 3.51 | 35.97 | 49.39 | 68.00 | -18.61 | |
| 10540.22 | 64.67 | 100 | 135 | | 50.43 | 4.45 | 38.71 | 57.39 | 68.00 | -10.61 | |
| 3540.03 | 59.17 | 100 | 135 | | 50.76 | 2.45 | 32.00 | 42.86 | 68.00 | -25.14 | Ch.62 |
| 7080.01 | 60.50 | 100 | 180 | | 50.39 | 3.52 | 36.11 | 49.74 | 68.00 | -18.26 | |
| 10620.41 | 66.33 | 100 | 135 | | 50.43 | 4.45 | 38.72 | 59.07 | 74.00 | -14.93 | |
| 10620.41 | | | | 52.02 A | 50.43 | 4.45 | 38.72 | 44.76 | 54.00 | -9.24 | |



Radiated Emissions Test Results (Continued)

*Spurious Emissions Measurements in 802.11n mode 40MHz Wide (5150-5350 MHz)
 Channels 38, 54, & 62
 Continuous RX at Chain B Antenna port with Sony IRX-3980 Antennas
 Aegis Labs, Inc. File #: INTEL-070320-10*

RADIATED EMISSIONS - Horizontal Antenna Polarization

| Freq. (MHz) | Meter Reading (dBuV) | Antenna Height (cm) | Azimuth (degrees) | Quasi pk or AVG (dBuV) | | Preamp Factor (dB) | Cable Factor (dB) | Ant. Factor (dB) | Corrected Reading (dBuV) | Limits (dBuV) | Diff (dB) +=FAIL | Comments |
|-------------|----------------------|---------------------|-------------------|------------------------|---|--------------------|-------------------|------------------|--------------------------|---------------|------------------|---------------|
| 3460.00 | 58.33 | 100 | 225 | | | 50.78 | 2.42 | 32.30 | 42.27 | 74.00 | -31.73 | Ch. 38 |
| 3460.00 | | | | 50.81 | A | 50.78 | 2.42 | 32.30 | 34.75 | 54.00 | -19.25 | |
| 3513.32 | 59.00 | 100 | 225 | | | 50.76 | 2.44 | 32.43 | 43.10 | 74.00 | -30.90 | Ch. 54 |
| 3513.32 | | | | 51.69 | A | 50.76 | 2.44 | 32.43 | 35.79 | 54.00 | -18.21 | |
| 3540.02 | 58.17 | 100 | 225 | | | 50.76 | 2.45 | 32.49 | 42.34 | 74.00 | -31.66 | Ch.62 |
| 3540.02 | | | | 50.47 | A | 50.76 | 2.45 | 32.49 | 34.64 | 54.00 | -19.36 | |

RADIATED EMISSIONS - Vertical Antenna Polarization

| Freq. (MHz) | Meter Reading (dBuV) | Antenna Height (cm) | Azimuth (degrees) | Quasi pk or AVG (dBuV) | | Preamp Factor (dB) | Cable Factor (dB) | Ant. Factor (dB) | Corrected Reading (dBuV) | Limits (dBuV) | Diff (dB) +=FAIL | Comments |
|-------------|----------------------|---------------------|-------------------|------------------------|---|--------------------|-------------------|------------------|--------------------------|---------------|------------------|---------------|
| 3460.02 | 60.17 | 100 | 225 | | | 50.78 | 2.42 | 31.81 | 43.62 | 74.00 | -30.38 | Ch. 38 |
| 3460.02 | | | | 53.28 | A | 50.78 | 2.42 | 31.81 | 36.73 | 54.00 | -17.27 | |
| 3513.26 | 59.50 | 100 | 225 | | | 50.76 | 2.44 | 31.93 | 43.11 | 74.00 | -30.89 | Ch. 54 |
| 3513.26 | | | | 52.86 | A | 50.76 | 2.44 | 31.93 | 36.47 | 54.00 | -17.53 | |
| 3540.02 | 58.83 | 100 | 180 | | | 50.76 | 2.45 | 32.00 | 42.52 | 74.00 | -31.48 | Ch.62 |
| 3540.02 | | | | 52.45 | A | 50.76 | 2.45 | 32.00 | 36.14 | 54.00 | -17.86 | |



Radiated Emissions Test Results (Continued)

*Fundamental Measurements in 802.11n mode 40MHz Wide (5150-5350 MHz)
 Channels 38, 54, & 62
 Continuous TX at Dual Chain AB Antenna port with Sony IRX-3980 Antennas
 Aegis Labs, Inc. File #: INTEL-070320-06*

| RADIATED EMISSIONS - Horizontal Antenna Polarization | | | | | | | | | | | | |
|---|----------------------|---------------------|-------------------|------------------------|---|----------------------|-------------------|------------------|--------------------------|---------------|------------------|---------------|
| Freq. (MHz) | Meter Reading (dBuV) | Antenna Height (cm) | Azimuth (degrees) | Quasi pk or AVG (dBuV) | | Distance Factor (dB) | Cable Factor (dB) | Ant. Factor (dB) | Corrected Reading (dBuV) | Limits (dBuV) | Diff (dB) +=FAIL | Comments |
| 5190.00 | 72.17 | 100 | 225 | | | 9.54 | 2.98 | 34.64 | 100.25 | | | Ch. 38 |
| 5190.00 | | | | 48.33 | A | 9.54 | 2.98 | 34.64 | 76.41 | | | |
| 5270.00 | 56.67 | 125 | 225 | | | 9.54 | 3.01 | 34.79 | 84.92 | | | Ch. 54 |
| 5270.00 | | | | 44.00 | A | 9.54 | 3.01 | 34.79 | 72.25 | | | |
| 5310.00 | 75.00 | 100 | 225 | | | 9.54 | 3.02 | 34.86 | 103.34 | | | Ch. 62 |
| 5310.00 | | | | 49.50 | A | 9.54 | 3.02 | 34.86 | 77.84 | | | |

| RADIATED EMISSIONS - Vertical Antenna Polarization | | | | | | | | | | | | |
|---|----------------------|---------------------|-------------------|------------------------|---|----------------------|-------------------|------------------|--------------------------|---------------|------------------|---------------|
| Freq. (MHz) | Meter Reading (dBuV) | Antenna Height (cm) | Azimuth (degrees) | Quasi pk or AVG (dBuV) | | Distance Factor (dB) | Cable Factor (dB) | Ant. Factor (dB) | Corrected Reading (dBuV) | Limits (dBuV) | Diff (dB) +=FAIL | Comments |
| 5190.00 | 70.83 | 100 | 225 | | | 9.54 | 2.98 | 34.40 | 98.68 | | | Ch. 38 |
| 5190.00 | | | | 46.83 | A | 9.54 | 2.98 | 34.40 | 74.68 | | | |
| 5270.00 | 56.17 | 100 | 180 | | | 9.54 | 3.01 | 34.53 | 84.17 | | | Ch. 54 |
| 5270.00 | | | | 44.50 | A | 9.54 | 3.01 | 34.53 | 72.50 | | | |
| 5310.00 | 73.00 | 100 | 225 | | | 9.54 | 3.02 | 34.60 | 101.07 | | | Ch. 62 |
| 5310.00 | | | | 48.83 | A | 9.54 | 3.02 | 34.60 | 76.90 | | | |

NOTE: Fundamental signals measured at 1 meter and extrapolated to 3 meters to calculate the radiated band edge field strengths.



Radiated Emissions Test Results (Continued)

*Band Edge Field Strength Measurements in 802.11n mode 40MHz Wide (5150-5350 MHz)
 Channels 38 & 62
 Continuous TX at Dual Chain AB Antenna port with Sony IRX-3980 Antennas
 Aegis Labs, Inc. File #: INTEL-070320-06*

| RADIATED EMISSIONS - Horizontal Antenna Polarization | | | | | | | | | | | | |
|---|----------------------|---------------------|-------------------|------------------------|---|----------------------|-------------------|------------------|--------------------------|---------------|------------------|---------------|
| Freq. (MHz) | Meter Reading (dBuV) | Antenna Height (cm) | Azimuth (degrees) | Quasi pk or AVG (dBuV) | | Distance Factor (dB) | Cable Factor (dB) | Ant. Factor (dB) | Corrected Reading (dBuV) | Limits (dBuV) | Diff (dB) +=FAIL | Comments |
| 5150.00 | 34.33 | 100 | 225 | | | 9.54 | 2.97 | 34.57 | 62.33 | 74.00 | -11.67 | Ch. 38 |
| 5150.00 | | | | 20.00 | A | 9.54 | 2.97 | 34.57 | 48.00 | 54.00 | -6.00 | |
| 5350.00 | 35.17 | 100 | 225 | | | 9.54 | 3.03 | 34.93 | 63.59 | 74.00 | -10.41 | Ch. 62 |
| 5350.00 | | | | 20.33 | A | 9.54 | 3.03 | 34.93 | 48.75 | 54.00 | -5.25 | |

| RADIATED EMISSIONS - Vertical Antenna Polarization | | | | | | | | | | | | |
|---|----------------------|---------------------|-------------------|------------------------|---|----------------------|-------------------|------------------|--------------------------|---------------|------------------|---------------|
| Freq. (MHz) | Meter Reading (dBuV) | Antenna Height (cm) | Azimuth (degrees) | Quasi pk or AVG (dBuV) | | Distance Factor (dB) | Cable Factor (dB) | Ant. Factor (dB) | Corrected Reading (dBuV) | Limits (dBuV) | Diff (dB) +=FAIL | Comments |
| 5150.00 | 31.67 | 100 | 225 | | | 9.54 | 2.97 | 34.34 | 59.44 | 74.00 | -14.56 | Ch. 38 |
| 5150.00 | | | | 19.50 | A | 9.54 | 2.97 | 34.34 | 47.27 | 54.00 | -6.73 | |
| 5350.00 | 34.33 | 100 | 225 | | | 9.54 | 3.03 | 34.66 | 62.48 | 74.00 | -11.52 | Ch. 62 |
| 5350.00 | | | | 20.50 | A | 9.54 | 3.03 | 34.66 | 48.65 | 54.00 | -5.35 | |

NOTE: The “Band Edge Field Strength” was calculated using the “Radiated Fundamental” measurements.



Radiated Emissions Test Results (Continued)

*Spurious Emissions Measurements in 802.11n mode 40MHz Wide (5150-5350 MHz)
 Channels 38, 54, & 62
 Continuous TX at Dual Chain AB Antenna port with Sony IRX-3980 Antennas
 Aegis Labs, Inc. File #: INTEL-070320-11*

RADIATED EMISSIONS - Horizontal Antenna Polarization

| Freq. (MHz) | Meter Reading (dBuV) | Antenna Height (cm) | Azimuth (degrees) | Quasi pk or AVG (dBuV) | Preamp Factor (dB) | Cable Factor (dB) | Ant. Factor (dB) | Corrected Reading (dBuV) | Limits (dBuV) | Diff (dB) +=FAIL | Comments |
|-------------|----------------------|---------------------|-------------------|------------------------|--------------------|-------------------|------------------|--------------------------|---------------|------------------|---------------|
| 3460.00 | 55.17 | 100 | 180 | | 50.78 | 2.42 | 32.30 | 39.11 | 68.00 | -28.89 | Ch. 38 |
| 6920.13 | 58.50 | 100 | 180 | | 50.49 | 3.48 | 35.92 | 47.40 | 68.00 | -20.60 | |
| 3513.33 | 54.83 | 100 | 135 | | 50.76 | 2.44 | 32.43 | 38.93 | 68.00 | -29.07 | Ch. 54 |
| 7026.76 | 59.67 | 100 | 180 | | 50.42 | 3.51 | 36.07 | 48.83 | 68.00 | -19.17 | |
| 3539.88 | 56.50 | 100 | 180 | | 50.76 | 2.45 | 32.49 | 40.67 | 68.00 | -27.33 | Ch.62 |
| 7080.03 | 58.17 | 100 | 180 | | 50.39 | 3.52 | 36.21 | 47.51 | 68.00 | -20.49 | |

RADIATED EMISSIONS - Vertical Antenna Polarization

| Freq. (MHz) | Meter Reading (dBuV) | Antenna Height (cm) | Azimuth (degrees) | Quasi pk or AVG (dBuV) | Preamp Factor (dB) | Cable Factor (dB) | Ant. Factor (dB) | Corrected Reading (dBuV) | Limits (dBuV) | Diff (dB) +=FAIL | Comments | |
|-------------|----------------------|---------------------|-------------------|------------------------|--------------------|-------------------|------------------|--------------------------|---------------|------------------|---------------|--|
| 3460.00 | 55.50 | 100 | 135 | | 50.78 | 2.42 | 31.81 | 38.95 | 68.00 | -29.05 | Ch. 38 | |
| 6920.13 | 58.83 | 100 | 135 | | 50.49 | 3.48 | 35.84 | 47.65 | 68.00 | -20.35 | | |
| 3513.33 | 57.83 | 100 | 135 | | 50.76 | 2.44 | 31.93 | 41.44 | 68.00 | -26.56 | Ch. 54 | |
| 7026.76 | 59.50 | 100 | 180 | | 50.42 | 3.51 | 35.97 | 48.56 | 68.00 | -19.44 | | |
| 10540.22 | 67.17 | 100 | 180 | | 50.43 | 4.45 | 38.71 | 59.89 | 68.00 | -8.11 | | |
| 3540.11 | 56.67 | 100 | 135 | | 50.76 | 2.45 | 32.00 | 40.36 | 68.00 | -27.64 | Ch.62 | |
| 7080.01 | 59.33 | 100 | 135 | | 50.39 | 3.52 | 36.11 | 48.57 | 68.00 | -19.43 | | |
| 10620.41 | 67.50 | 100 | 180 | | 50.43 | 4.45 | 38.72 | 60.24 | 74.00 | -13.76 | | |
| 10620.41 | | | | 53.16 | A | 50.43 | 4.45 | 38.72 | 45.90 | 54.00 | -8.10 | |



PEAK TRANSMIT POWER

| | | | |
|-----------------------|---|----------------------------|--------------|
| CLIENT: | Intel Corporation | DATE: | 03/29/07 |
| EUT: | Intel Wireless WiFi Link 4965AGN | PROJECT NUMBER: | INTEL-070320 |
| MODEL NUMBER: | 4965AGN | TEST ENGINEER: | BM/JC |
| SERIAL NUMBER: | 0013E804612B | SITE #: | 1 |
| CONFIGURATION: | Tested installed in the host computer's mini PCI slot. | TEMPERATURE: | 23 deg. C |
| | | HUMIDITY: | 22% RH |
| | | TIME: | 2:00 PM |

| | |
|---------------------|---|
| Description: | <p>For the band 5.15-5.25 GHz, the peak transmit power over the frequency band of operation shall not exceed the lesser of 50 mW or $4 \text{ dBm} + 10\log B$, where B is the 26-dB emission bandwidth in MHz.</p> <p>For the band 5.25-5.35 GHz, the peak transmit power over the frequency band of operation shall not exceed the lesser of 250 mW or $11 \text{ dBm} + 10\log B$, where B is the 26-dB emission bandwidth in MHz.</p> |
| Results: | Passed (See Data Sheet) |
| Note: | <p>Conducted Emissions Measurements were performed on the EUT with power supply set at the following voltage and frequency.</p> <ul style="list-style-type: none">• 120VAC / 60 Hz. |



Peak Transmit Power (Continued)

| Mode | Channel | Frequency (MHz) | Chain | Data Rate (Mbps) | Average Power (dBm) | Average Power (mW) | Peak Power (dBm) | Peak Power (mW) |
|-----------------|---------|-----------------|-------|------------------|---------------------|--------------------|------------------|-----------------|
| 802.11a | 36 | 5180 | A | 6 | 15.38 | 34.51 | 16.61 | 45.81 |
| 802.11a | 48 | 5240 | A | 6 | 15.46 | 35.15 | 16.81 | 47.97 |
| 802.11a | 52 | 5260 | A | 6 | 17.50 | 56.23 | 18.61 | 72.60 |
| 802.11a | 64 | 5320 | A | 6 | 16.46 | 44.25 | 18.41 | 69.34 |
| 802.11a | 36 | 5180 | B | 6 | 15.43 | 34.91 | 16.81 | 47.97 |
| 802.11a | 48 | 5240 | B | 6 | 15.52 | 35.64 | 16.91 | 49.09 |
| 802.11a | 52 | 5260 | B | 6 | 17.57 | 57.14 | 19.41 | 87.29 |
| 802.11a | 64 | 5320 | B | 6 | 16.54 | 45.08 | 19.11 | 81.46 |
| | | | | | | | | |
| 802.11n | 36 | 5180 | A | HT0 | 15.49 | 35.40 | 16.91 | 49.09 |
| 802.11n | 48 | 5240 | A | HT0 | 15.35 | 34.27 | 16.71 | 46.88 |
| 802.11n | 52 | 5260 | A | HT0 | 17.46 | 55.71 | 18.81 | 76.03 |
| 802.11n | 64 | 5320 | A | HT0 | 16.51 | 44.77 | 18.41 | 69.34 |
| 802.11n | 36 | 5180 | B | HT0 | 15.47 | 35.23 | 16.71 | 46.88 |
| 802.11n | 48 | 5240 | B | HT0 | 15.61 | 36.39 | 16.81 | 47.97 |
| 802.11n | 52 | 5260 | B | HT0 | 17.53 | 56.62 | 19.21 | 83.36 |
| 802.11n | 64 | 5320 | B | HT0 | 16.50 | 44.66 | 18.71 | 74.29 |
| | | | | | | | | |
| 802.11n (40MHz) | 38 | 5190 | A | HT0 | 15.36 | 34.35 | 16.51 | 44.76 |
| 802.11n (40MHz) | 54 | 5270 | A | HT0 | 17.43 | 55.33 | 18.51 | 70.95 |
| 802.11n (40MHz) | 62 | 5310 | A | HT0 | 15.30 | 33.88 | 16.41 | 43.74 |
| 802.11n (40MHz) | 38 | 5190 | B | HT0 | 15.35 | 34.27 | 16.41 | 43.74 |
| 802.11n (40MHz) | 54 | 5270 | B | HT0 | 17.38 | 54.69 | 18.91 | 77.79 |
| 802.11n (40MHz) | 62 | 5310 | B | HT0 | 15.41 | 34.75 | 16.21 | 41.78 |

NOTE: The output power measurement is conducted.



Peak Transmit Power (Continued)

| Mode | Channel | Freq. (MHz) | Data Rate (Mbps) | Avg. Power (dBm) Ch. A | Avg. Power (mW) Ch. A | Peak Power (dBm) Ch. A | Peak Power (mW) Ch. A | Avg. Power (dBm) Ch. B | Avg. Power (mW) Ch. B | Peak Power (dBm) Ch. B | Peak Power (mW) Ch. B |
|-----------------|---------|-------------|------------------|------------------------|-----------------------|------------------------|-----------------------|------------------------|-----------------------|------------------------|-----------------------|
| 802.11n (20MHz) | 36 | 5180 | HT 8 | 12.59 | 18.14 | 13.78 | 23.86 | 12.51 | 17.81 | 13.85 | 24.25 |
| 802.11n (20MHz) | 48 | 5240 | HT 8 | 12.70 | 18.61 | 13.50 | 22.37 | 12.46 | 17.61 | 13.64 | 23.11 |
| 802.11n (20MHz) | 52 | 5260 | HT 8 | 14.61 | 28.89 | 16.99 | 49.97 | 14.40 | 27.53 | 17.19 | 52.33 |
| 802.11n (20MHz) | 64 | 5320 | HT 8 | 14.41 | 27.59 | 17.09 | 51.14 | 14.32 | 27.02 | 17.29 | 53.55 |
| 802.11n (40MHz) | 38(F) | 5190 | HT 8 | 12.51 | 17.83 | 14.04 | 25.36 | 12.56 | 18.04 | 13.84 | 24.22 |
| 802.11n (40MHz) | 46(F) | 5270 | HT 8 | 14.50 | 28.19 | 17.64 | 58.09 | 14.57 | 28.65 | 17.54 | 56.77 |
| 802.11n (40MHz) | 62(F) | 5310 | HT 8 | 14.42 | 27.68 | 17.84 | 60.83 | 14.57 | 28.65 | 17.94 | 62.25 |

| Mode | Channel | Freq. (MHz) | Data Rate (Mbps) | Aggregate Avg. Output Power (dBm) Ch. A + B | Aggregate Avg. Output Power (mW) Ch. A + B | Aggregate Peak Output Power (dBm) Ch. A + B | Aggregate Peak Output Power (mW) Ch. A + B |
|-----------------|---------|-------------|------------------|---|--|---|--|
| 802.11n (20MHz) | 36 | 5180 | HT 8 | 15.56 | 35.96 | 16.82 | 48.12 |
| 802.11n (20MHz) | 48 | 5240 | HT 8 | 15.59 | 36.22 | 16.58 | 45.48 |
| 802.11n (20MHz) | 52 | 5260 | HT 8 | 17.51 | 56.42 | 20.10 | 102.30 |
| 802.11n (20MHz) | 64 | 5320 | HT 8 | 17.37 | 54.61 | 20.20 | 104.69 |
| 802.11n (40MHz) | 38(F) | 5190 | HT 8 | 15.55 | 35.86 | 16.95 | 49.58 |
| 802.11n (40MHz) | 46(F) | 5270 | HT 8 | 17.55 | 56.84 | 20.60 | 114.86 |
| 802.11n (40MHz) | 62(F) | 5310 | HT 8 | 17.51 | 56.33 | 20.90 | 123.08 |

(F) = Fat Channel



CONDCUTED BAND EDGE EMISSIONS TEST RESULTS

| | | | |
|-----------------------|---|----------------------------|--------------|
| CLIENT: | Intel Corporation | DATE: | 03/29/07 |
| EUT: | Intel Wireless WiFi Link 4965AGN | PROJECT NUMBER: | INTEL-070320 |
| MODEL NUMBER: | 4965AGN | TEST ENGINEER: | BM/JC |
| SERIAL NUMBER: | 0013E804612B | SITE #: | 1 |
| CONFIGURATION: | Tested installed in the host computer's mini PCI slot. | TEMPERATURE: | 23 deg. C |
| | | HUMIDITY: | 22% RH |
| | | TIME: | 2:00 PM |

| | |
|---------------------|--|
| Description: | For transmitters operating in the 5.25-5.35 GHz band: all emissions outside of the 5.15-5.35 GHz band shall not exceed an EIRP of -27 dBm/MHz. Devices operating in the 5.25-5.35 GHz band that generate emissions in the 5.15-5.25 GHz band must meet all applicable technical requirements for operation in the 5.15-5.25 GHz band (including indoor use) or alternatively meet an out-of-band emission EIRP limit of -27 dBm/MHz in the 5.15-5.25 GHz band. |
| Results: | See Data Sheet |
| Note: | Conducted Emissions Measurements were performed on the EUT with power supply set at the following voltage and frequency. <ul style="list-style-type: none"> 120VAC / 60 Hz. |

| Unwanted Spurious Emissions Limits | |
|------------------------------------|---|
| Frequency (MHz) | Field Strength (dBm/Hz) (Emissions outside the restricted bands) |
| 5250-5350 | EIRP < -27dBm/Hz (68.3dBuV/m) |

| Freq. (MHz) | Power Spec Den. Reading (dBm/Hz) | Antenna Gain (dBi) | Corrected Reading (dBm/Hz) | Limits (dBm/Hz) | Diff (dB) +=FAIL | Comments |
|---|----------------------------------|--------------------|----------------------------|-----------------|---------------------|---------------|
| With Sony IRX-3980 Antennas (Gain at 5GHz) Transmitting on Chain A | | | | | | |
| 5250.00 | -34.50 | 1.62 | -32.88 | -27.00 | -5.88 | Tx @ 5240 MHz |
| 5250.00 | -33.70 | 1.62 | -32.08 | -27.00 | -5.08 | Tx @ 5260 MHz |
| With Sony IRX-3980 Antennas (Gain at 5GHz) Transmitting on Chain B | | | | | | |
| 5250.00 | -34.50 | 1.62 | -32.88 | -27.00 | -5.88 | Tx @ 5240 MHz |
| 5250.00 | -33.70 | 1.62 | -32.08 | -27.00 | -5.08 | Tx @ 5260 MHz |

Conducted Band Edge Emissions Test Results (Continued)

802.11a Mode

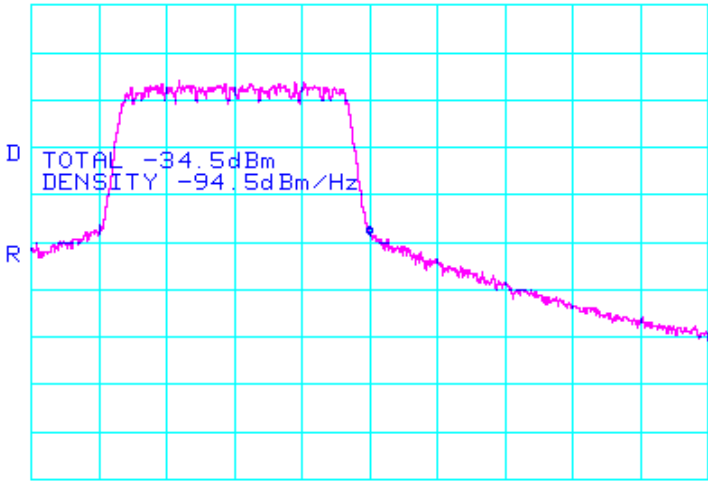
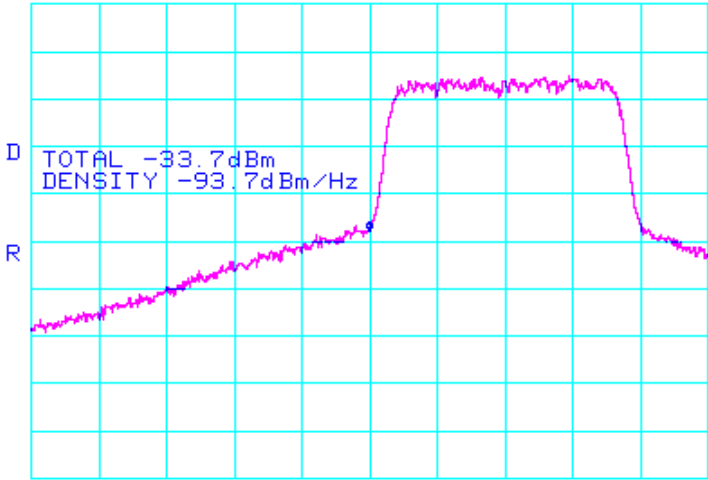
| Test Date | Data | Chain | Test Eng. |
|--|--|-------|-----------|
| 09/20/06 | 5.24 GHz band edge (INTEL-070320-25g01) | A | JC |
| <p>*ATTEN 20dB VAUG 100 MKR -32.50dBm RL 16.0dBm 10dB/ 5.25000GHz</p>  <p>D TOTAL -34.5dBm DENSITY -94.5dBm/Hz</p> <p>R</p> <p>CENTER 5.25000GHz SPAN 50.00MHz *RBW 1.0MHz *VBW 1.0MHz SWP 50.0ms</p> | | | |
| 09/20/06 | 5.26 GHz band edge (INTEL-070320-25g02) | A | JC |
| <p>*ATTEN 20dB VAUG 100 MKR -31.83dBm RL 16.0dBm 10dB/ 5.25000GHz</p>  <p>D TOTAL -33.7dBm DENSITY -93.7dBm/Hz</p> <p>R</p> <p>CENTER 5.25000GHz SPAN 50.00MHz *RBW 1.0MHz *VBW 1.0MHz SWP 50.0ms</p> | | | |

Conducted Band Edge Emissions Test Results (Continued)

802.11a Mode

| Test Date | Data | Chain | Test Eng. |
|-----------|--|-------|-----------|
| 09/20/06 | 5.24 GHz band edge (INTEL-070320-25g03) | B | JC |

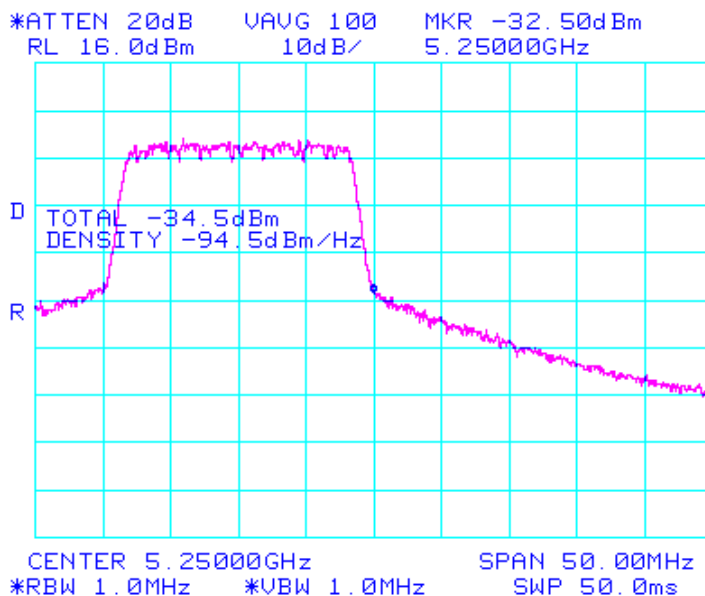

| Test Date | Data | Chain | Test Eng. |
|-----------|--|-------|-----------|
| 09/20/06 | 5.26 GHz band edge (INTEL-070320-25g04) | B | JC |

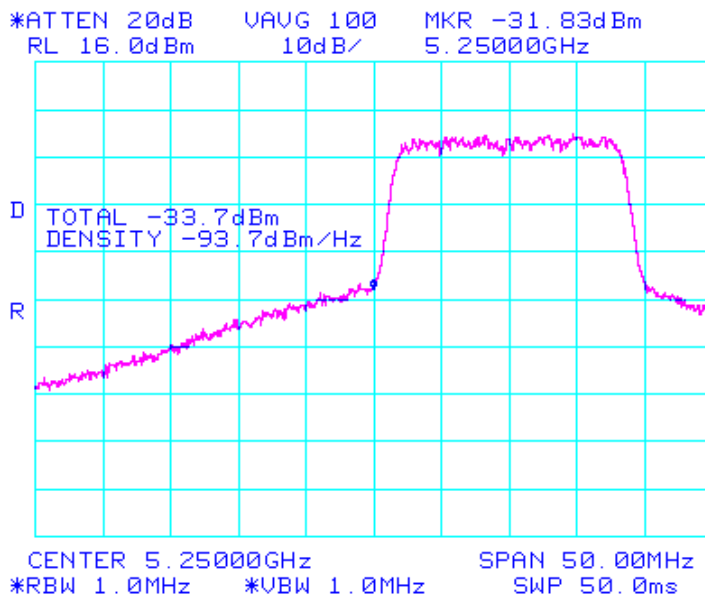



APPENDIX B

MODIFICATIONS AND RECOMMENDATIONS

| | |
|------------|------|
| 1.0 | NONE |
| | |