

**TEST REPORT CONCERNING THE COMPLIANCE  
OF AN INTEL® DUAL BAND WIRELESS CARD  
MODEL 3168NGW,  
WITH 47 CFR PART 15-SUBPART B (10-1-14 Edition)  
AND THE  
REQUIREMENTS OF INDUSTRY CANADA:  
ICES-003 (ISSUE 5, AUGUST 2012).**

**16011301.f01  
February 4, 2016**

FCC listed : 90828  
Industry Canada : 2932G-2  
R&TTE and EMC Notified Body : 1856

**TÜV Rheinland Nederland B.V.  
P.O. Box 37  
9350 AA Leek (NL)  
Eiberkamp 10  
9351 VT Leek (NL)**

Telephone: +31 594 505005  
Telefax: +31 594 504804

Internet: [www.tuv.com/nl](http://www.tuv.com/nl)  
E-mail: [products@nl.tuv.com](mailto:products@nl.tuv.com)

## MEASUREMENT/TECHNICAL REPORT

### Intel Mobile Communication SAS (France) Model: 3168NGW

This report concerns:	Original certification	<del>Class 2 change</del>	Verification / DoC
Equipment type:	Intel® Dual Band Wireless card with Bluetooth		
Report prepared by:	Name	: T.E.T. Koning	
	Company name	: TÜV Rheinland Nederland B.V.	
	Address	: Eiberkamp 10	
	Postal code/city	: 9351 VT Leek	
	Mailing address	: P.O. Box 37	
	Postal code/city	: 9350 AA Leek	
	Country	: The Netherlands	
	Telephone number	: + 31 594 505 005	
	Telefax number	: + 31 594 504 804	
	E-mail	: products@nl.tuv.com	

The data taken for this test and report herein was done in accordance with 47 CFR Part 15, Subpart B (10-1-14 edition), ICES-003 (Issue 5, August 2012) and the measurement procedures of ANSI C63.4-2013. TÜV Rheinland Nederland B.V. at Leek, The Netherlands, certifies that the data is accurate and contains a true representation of the emission profile of the Equipment Under Test (EUT) on the date of the test as noted in the test report. I have reviewed the test report and find it to be an accurate description of the test(s) performed and the EUT so tested.

Date: February 8, 2016

Signature:

  
T.E.T. Koning  
Senior Engineer EMC TÜV Rheinland Nederland B.V.

### Summary

The device under test does:

- fulfill the general approval requirements as identified in this test report
- not fulfill the general approval requirements as identified in this test report

### Description of test item

Test item : Intel® Dual Band Wireless card with Bluetooth  
Manufacturer : Intel Mobile Communications SAS  
Brand : Intel  
Models : 3168NGW  
Serial number : ---

### Applicant information

Applicants representative: Mrs. L. Peignot  
Company : Intel Mobile Communications SAS  
Address : Le Navigator B / 505 route des Lucioles / CS 70293  
City : 06905 Sophia Antipolis Cedex  
Country : France  
Telephone number : +33 (0)4 93 00 14 14  
Telefax number : +33 (0)4 93 00 14 01

### Test(s) performed

Location : Leek  
Test(s) started : January 29, 2016  
Test(s) completed : February 3, 2016  
Purpose of test(s) : Original certification  
Test specification(s) : 47 CFR Part 15, subpart B (10-1-14 Edition) and  
ICES-003 (ISSUE 5, AUGUST 2012)

Test engineer(s) : K.F. van der Molen

Report written by : K.F. van der Molen



Report date : February 4, 2016

This report shall not be reproduced, except in full, without the written permission of TÜV Rheinland Nederland B.V.  
The test results relate only to the item(s) tested.

## **Table of contents**

1	General information.....	5
1.1	Product description.....	5
1.1.1	Introduction.....	5
1.2	Related submittal(s) and/or Grant(s).....	5
1.2.1	General.....	5
1.3	Tested system details.....	5
1.3.1	Description of input/output ports.....	7
1.4	Test Summary.....	8
1.5	Test methodology.....	9
1.6	Test facility.....	9
1.7	Test conditions.....	9
2	System test configuration.....	10
2.1	Justification.....	10
2.2	EUT mode of operation.....	10
2.3	Special accessories.....	10
2.4	Equipment modifications.....	10
2.5	Product Labelling.....	10
2.6	Block diagram of the EUT.....	10
2.7	Schematics of the EUT.....	10
2.8	Part list of the EUT.....	10
3	Radiated emission data.....	11
3.1	System Radiated emissions data (30 MHz – 1 GHz).....	12
4	AC Power-line Conducted emission data.....	13
4.1.1	Testresults.....	14
5	List of utilized test equipment.....	16
6	Testsetup photographs.....	17
6.1	Testsetup photographs radiated emissions.....	17
6.2	Testsetup photographs AC power line conducted emissions.....	18

## 1 General information.

### 1.1 Product description.

#### 1.1.1 Introduction.

The EUT is a Dual band wireless card with Bluetooth.

The content of this report and measurement results have not been changed other than the way of presenting the data.

### 1.2 Related submittal(s) and/or Grant(s).

#### 1.2.1 General.

None issued

### 1.3 Tested system details.

Details and an overview of the system and all of its components, as it has been tested, may be found below.

Test item (EUT1)	:	Intel® Dual Band Wireless card with Bluetooth
Manufacturer	:	Intel Mobile Communication SAS
Brand mark	:	Intel
Model	:	3168NGW
Serial number	:	---
Remark	:	Tested in a Extender(AUX1) connected to a notebook(AUX2)

Test item (AUX 1)	:	NGFF Extender
Manufacturer	:	Intel Mobile Communication SAS
Brand mark	:	Intel
Model	:	PCB00435
Serial number	:	REV.02
Remark	:	Host for EUT

Test item (AUX2)	:	Notebook
Manufacturer	:	Dell
Brand mark	:	Dell
Model	:	P16G
Serial number	:	--
Remark	:	connected with AUX1

Test item (AUX3)	:	Wireless router
Manufacturer	:	Netgear
Brand mark	:	Netgear
Model	:	WNDR3300
Serial number	:	1TR2837100A88
Remark	:	--

Test item (AUX4) : Mobile phone with Bluetooth  
Manufacturer : Sony  
Brand mark : Sony  
Model : D2303  
Serial number : --  
Remark : --

Test item (AUX5 and 6) : Antennas  
Manufacturer : SkyCross Electronics Co., Ltd.  
Brand mark : SkyCross  
Model : WIMAX/WLAN  
Serial number : --  
Remark : --

Test item (AUX7) : Notebook  
Manufacturer : Fujitsu  
Brand mark : Fujitsu  
Model : A512  
Serial number : YLNC277385  
Remark : --

1.3.1 Description of input/output ports

Number	Terminal	From	To	Remarks
1	Mains	Mains (power supply)	AUX2	Used for powering/charging AUX2

Table 1: Interconnection between EUT and auxiliary equipment

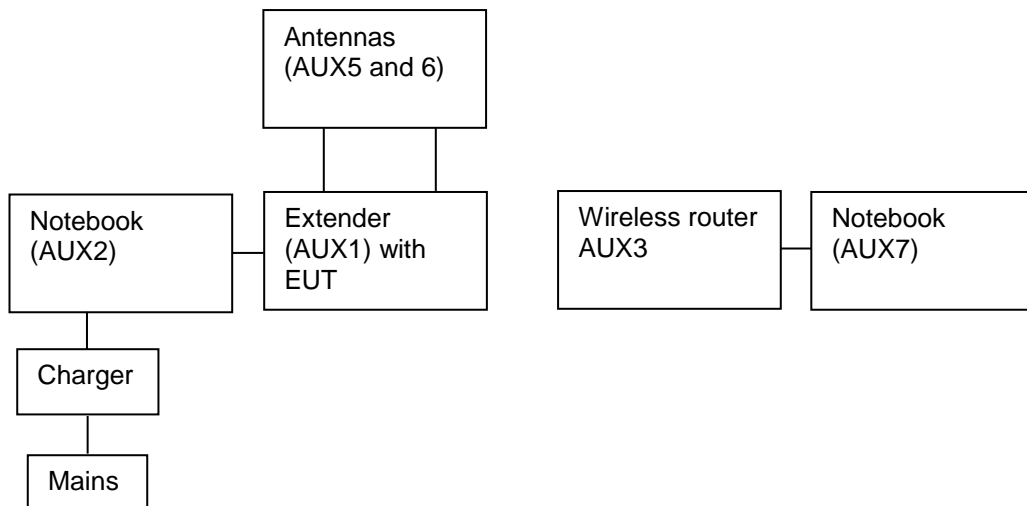

Figure 1 Set-up during testing



Photo 1: EUT.

#### 1.4 Test Summary

The EUT was tested in accordance with the specifications given in the table below.

Test Standard		Description	Page	Pass / Fail
47 CFR Part 15 Subpart B (10-1-14 Edition)	ICES-003 Issue 5, August 2012			
15.107(a)	Section 6.1 Table 2	AC Power Line Conducted emissions	12 – 15	<b>Pass</b>
15.109(a)	Section 6.2.1 Table 5	Radiated emissions	10 – 11	<b>Pass</b>

Table : testspecifications

Testmethods: ANSI C63.4-2014

Note: see end of the report for setup photographs.



## 1.5 Test methodology.

The test methodology used is based on the requirements of 47 CFR Part 15, Subpart B (10-1-14 Edition), sections 15.107 and 15.109 and ICES-003 Issue 5 (august 2012) Sections 6.1 and 6.2.

The test methods, which have been used, are based on ANSI C63.4-2014.

Radiated emission tests above 30 MHz were performed at a measurement distance of 3 meters. To calculate the field strength level from these results to the appropriate distance at which the limit is specified, the appropriate extrapolation factor is used.

The receivers are switching automatically to the right bandwidth in accordance with CISPR 16. This is implemented in the receiver. The antenna factors are programmed in the test receiver. The receiver automatically calculates the appropriate correction factor for the utilized antenna and also the appropriate antenna factor for the cable loss. The total correction is automatically added to the measured value.

## 1.6 Test facility.

The Federal Communications Commission and Industry Canada has reviewed the technical characteristics of the test facilities at TÜV Rheinland Nederland B.V., located in Leek, 9351VT Eiberkamp 10, The Netherlands, and has found these test facilities to be in compliance with the requirements of 47 CFR Part 15, section 2.948.

The description of the test facilities has been filed at the Office of the Federal Communications Commission under registration number 90828. The facility has been added to the list of laboratories performing these test services for the public on a fee basis.

The description of the test facilities has been filed to Industry Canada under registration number 2932G-2. The facility has been added to the list of laboratories performing these test services for the public on a fee basis.

## 1.7 Test conditions.

Normal test conditions:

Temperature (*)	: +15°C to +35°C
Relative humidity(*)	: 20 % to 75 %
Supply voltage	: 120VAC
Air pressure	: 950 – 1050 hPa

When it was impracticable to carry out the tests under these conditions, a note to this effect stating the ambient temperature and relative humidity during the tests are stated separately.

## **2 System test configuration.**

### **2.1 Justification.**

The system was configured for testing in a typical fashion (as a customer would normally use it).

The justification and manipulation of cables and equipment in order to simulate a worst-case behavior of the test setup has been carried out as prescribed in ANSI C63.4-2014.

### **2.2 EUT mode of operation.**

Testing where performed while EUT was operating in normal operating mode

### **2.3 Special accessories.**

No special accessories are used and/or needed to achieve compliance.

### **2.4 Equipment modifications.**

No modifications have been made to the equipment.

No modifications have been made to the equipment in order to achieve compliance.

### **2.5 Product Labelling**

The product labeling information is available in the technical documentation package.

### **2.6 Block diagram of the EUT.**

The block diagram is available in the technical documentation package.

### **2.7 Schematics of the EUT.**

The schematics are available in the technical documentation package.

### **2.8 Part list of the EUT.**

The part list is available in the technical documentation package.

### 3 Radiated emission data.

#### RESULT: PASS

Date of testing: 2016-02-03

Frequency range: 30MHz - 1000MHz

Requirements:

FCC 15.109(a) and IC ICES-003 section 6.2

Except for Class A digital devices, the field strength of radiated emissions from an unintentional radiator shall not exceed the field strength levels specified in the following table:

Frequency (MHz)	Field strength (µV/m)	Field strength (dBµV/m)	Measurement distance (meters)
30-88	100	40.0	3
88-216	150	43.5	3
216-960	200	46.0	3
Above 960	500	54.0	3

#### Test procedure:

ANSI C63.4-2014.

The EUT was placed on a nonconductive turntable 0.8m above the ground plane. Before final measurements of radiated emissions were performed, the EUT was scanned to determine its emission spectrum profile. The physical arrangement of the test system, the associated cabling and the EUT orientation (X, Y, Z) were varied in order to ensure that maximum emission amplitudes were attained.

The spectrum was examined from 30 MHz to 1 GHz. Final radiated emission measurements were made at 3m distance.

At each frequency where a spurious emission was found, the EUT was rotated 360° and the antenna was raised and lowered from 1 to 4m in order to determine the emission's maximum level. Measurements were taken using both horizontal and vertical antenna polarizations.

The highest emission amplitudes relative to the appropriate limit were recorded in this report. Field strength values of radiated emissions at frequencies not listed in the tables are more than 20 dB below the applicable limit.

### 3.1 System Radiated emissions data (30 MHz – 1 GHz).

Frequency (MHz)	Antenna polarization Measurement results @3m (dB $\mu$ V/m)		Limits Qp @3m (dB $\mu$ V/m)	Pass/Fail
	Vertical	Horizontal		
32.40	32.9	15.8	39.5	Pass
91.32	23.9	29.9	43.0	Pass
99.96	28.7	32.9	43.0	Pass
104.64	23.6	22.0	43.0	Pass
144.00	34.5	38.4	43.0	Pass
780.00	31.6	37.3	46.0	Pass
840.00	34.8	39.1	46.0	Pass

Table 1 Radiated emissions of the EUT

The results of the radiated emission tests, carried out in accordance with 47 CFR Part 15 section 15.109 and ICES-003 are depicted in Table 1. The system is tested as in whole, so with all equipment as shown in Figure.1 in place and functioning. Being the worst case situation.

#### Notes:

1. Field strength values of radiated emissions at frequencies not listed in the table above are more than 20 dB below the applicable limit.
2. Measurement uncertainty is  $\pm 5.0$ dB
3. The reported field strength values are the worst case values at the indicated frequency. The EUT was varied in 3 positions, the antenna was varied in horizontal and vertical orientations and also in height (between 1m and 4m).
4. A Quasi-peak detector was used with a resolution bandwidth of 120 kHz.
5. The EUT was tested in in normal operation mode. Worst case values have been noted.

Used test equipment and ancillaries:

A00257	A00258	A00314	A00450	A00447	A00235	A00466	A00444	

## 4 AC Power-line Conducted emission data.

**RESULT: Pass.**

Date of testing: 2016-02-03

Requirements:

Except when the requirements applicable to a given device state otherwise, for any license-exempt radio communication device equipped to operate from the public utility AC power supply, either directly or indirectly, the radio frequency voltage that is conducted back onto the AC power lines in the frequency range of 0.15 MHz to 30 MHz shall not exceed the limits shown in the following table. The tighter limit applies at the frequency range boundaries.

Frequency of Emission (MHz)	Conducted Limit (dB $\mu$ V) Quasi-Peak	Conducted Limit (dB $\mu$ V) Average
0.15 – 0.5	66 to 56*	56 to 46*
0.5 – 5	56	46
5 - 30	46	50

\*Decreases with the logarithm of the frequency.

Test procedure:

ANSI C63.4-2013.

Each phase and neutral of the AC power line were measured with respect to ground. Measurements were performed using a 50  $\mu$ H / 50  $\Omega$  LISN. The frequency range from 150kHz to 30MHz was searched. The six highest EUT emissions relative to the limit were noted. The EUT is placed on a non-conductive table 0.8m above the ground plane. The EUT was positioned at least 80cm from the LISN. The power cable was routed over the non-conductive plate to the LISN.

#### 4.1.1 Testresults

Frequency (MHz)	Measurement results N (dBµV)		Measurement results L1 (dBµV)		Limits (dBµV)		Verdict (Pass/Fail)
	QP	AV	QP	AV	QP	AV	
0.153	44.7	29.5	44.1	27.1	65.8	55.8	Pass
0.181	47.0	32.0	47.4	33.6	64.4	54.4	Pass
0.193	36.7	24.0	38.0	24.9	63.9	53.9	Pass
0.239	38.0	26.4	39.0	28.2	62.1	52.1	Pass
0.314	38.4	28.1	38.7	28.5	59.8	49.8	Pass
3.607	23.6	15.0	24.0	14.2	56.0	46.0	Pass

Table 2 Conducted emissions results.

The results of the conducted emission tests, carried out in accordance with 47 CFR Part 15 section 15.107(a) and ICES-003 Section 6.1 Table 2 Class B, at the 120 Volts/ 60 Hz AC mains connection terminals of the EUT, are depicted in the table above.

Notes:

1. The resolution bandwidth used was 9 kHz.
2. Tested in the normal operation mode. Worst case values noted.
3. Plots are provided on the next pages.

Used test equipment and ancillaries:

A00022	A00171	A00437	A00441	A00314	

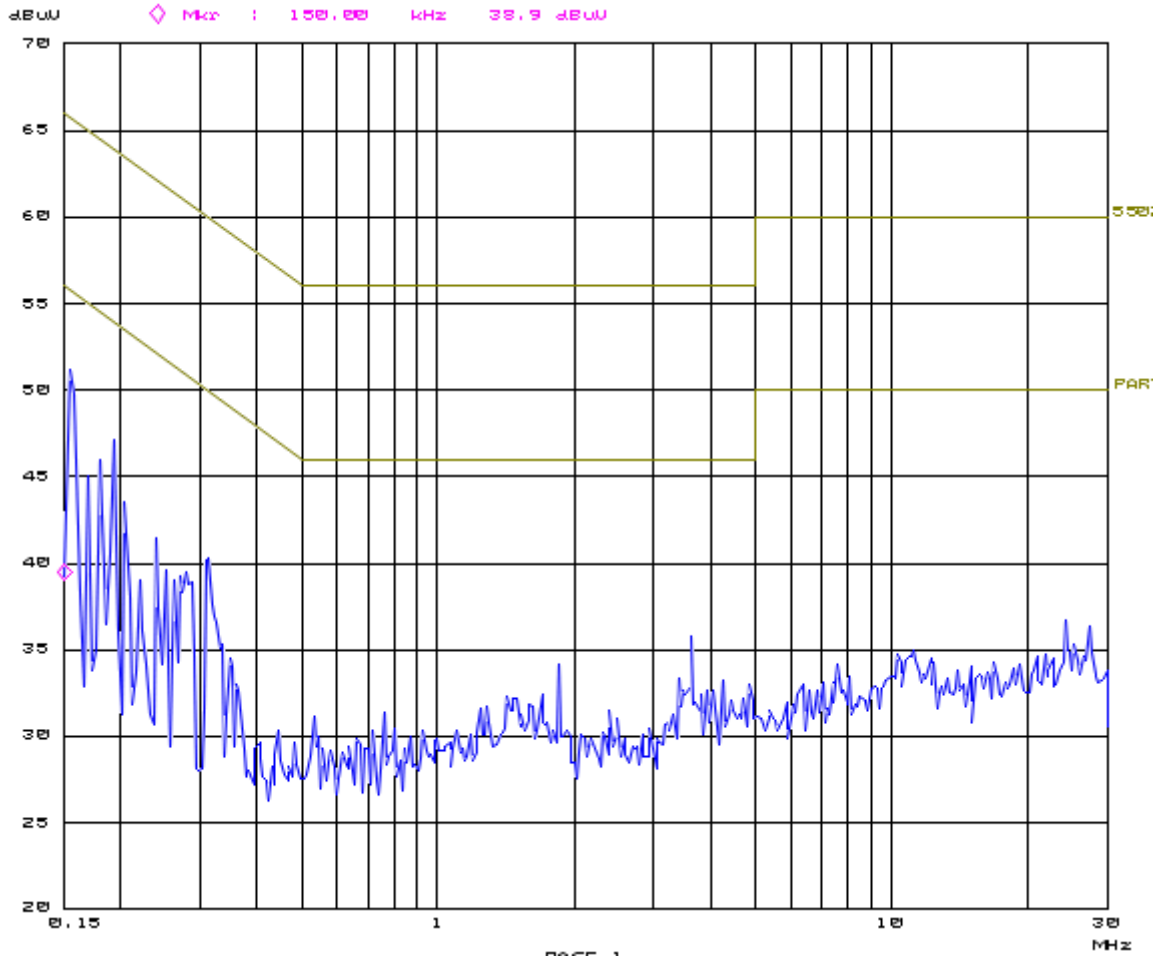

Plot EUT1

## 5 List of utilized test equipment.

Kind of Equipment	Manufacturer	Model Name	Inventory number	Calibration date (mm/yyyy)	Calibration due date (mm/yyyy)
<b>For Radiated Emissions</b>					
Measurement Receiver	Rohde & Schwarz	ESCI	A00314	03/2015	03/2016
RF Cable S-AR	Gigalink	APG0500	A00447	01/2015	01/2016
Controller	Maturo	SCU/088/ 8090811	A00450	N/A	N/A
Controller	EMCS	DOC202	A00257	N/A	N/A
Test facility	Comtest	FCC listed: 90828 IC: 2932G-2	A00235	04/2014	04/2017
Antenna mast	EMCS	AP-4702C	A00258	N/A	N/A
Temperature-Humiditymeter	Extech	SD500	A00444	03/2015	03/2016
Biconilog Testantenna	Teseq	CBL 6111D	A00466	06/2015	06/2016
<b>For AC Power Line</b>					
	<b>Conducted</b>	<b>Emissions</b>			
Variac	RFT	LSS020	A00171	NA	NA
LISN	EMCO	3625/2	A00022	01/2014	01/2016
Measurement Receiver	Rohde & Schwarz	ESCI	A00314	03/2015	03/2016
Shielded room for Conducted emissions	--	--	A00437	NA	NA
Temperature-Humiditymeter	Extech	SD500	A00444	03/2015	03/2016

NA= Not Applicable

Conformance of the used measurement and test equipment with the requirements of ISO/IEC 17025:2005 has been confirmed before testing.



## 6 Testsetup photographs

### 6.1 Testsetup photographs radiated emissions

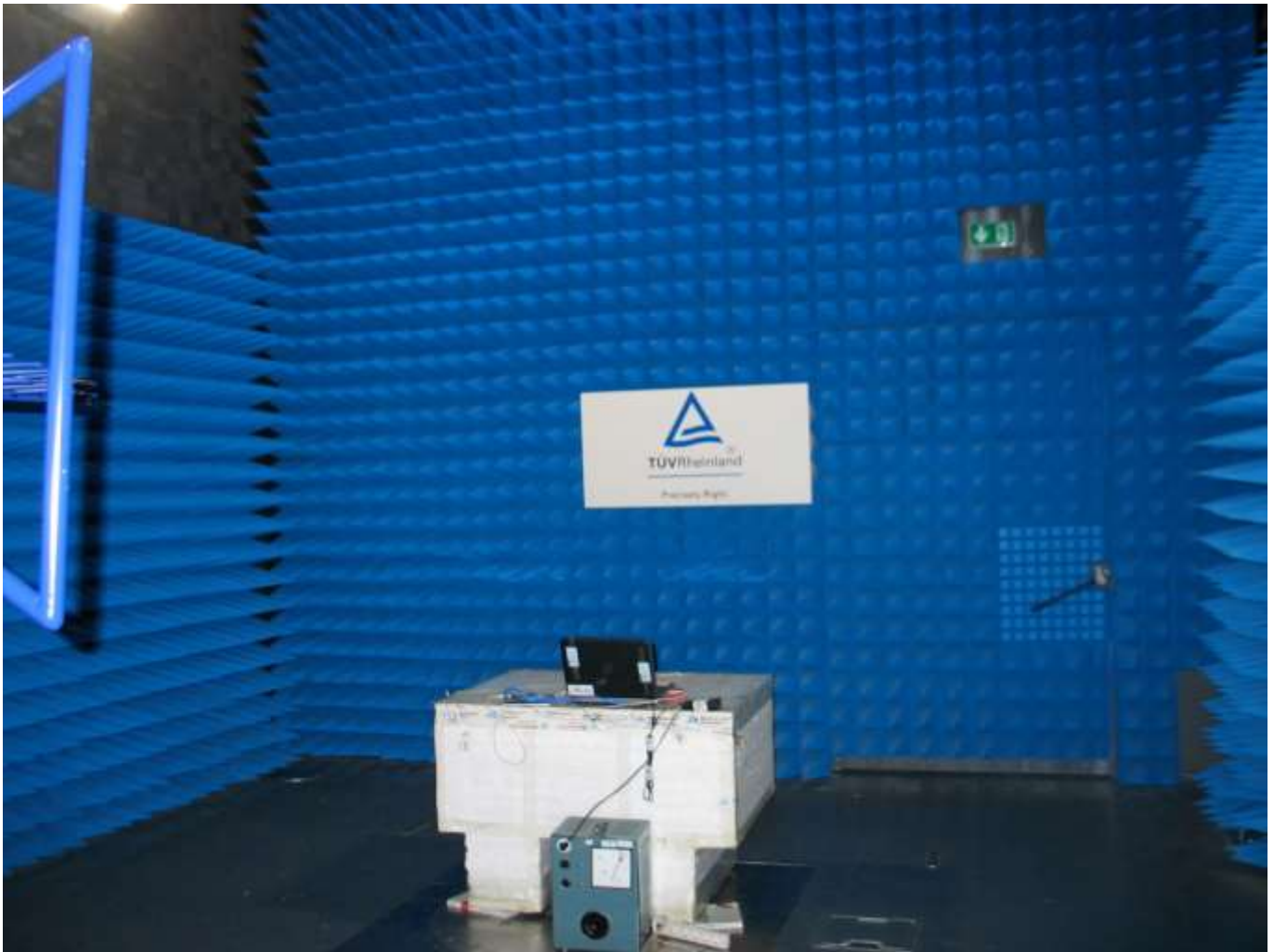

## 6.2 Testsetup photographs AC power line conducted emissions



Photo 2. Conducted emission